

EXISTING URBAN TYPICAL SECTION

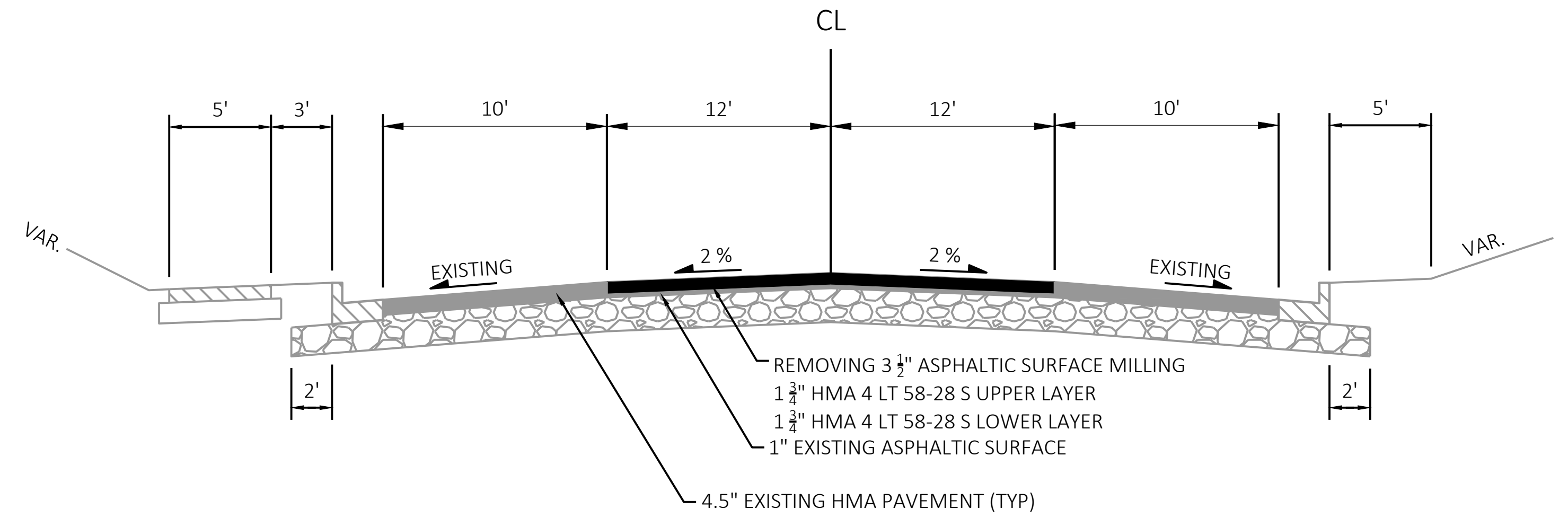

FINISHED URBAN TYPICAL SECTION

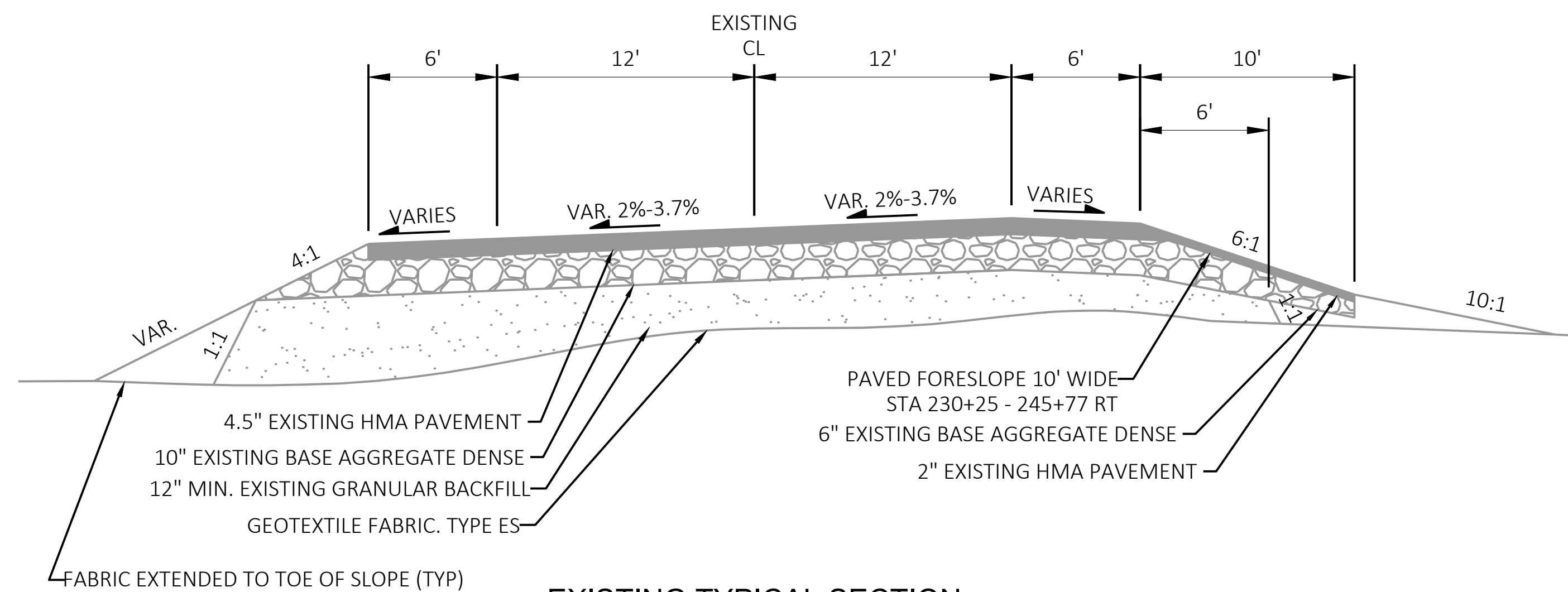

EXISTING TYPICAL SECTION

URBAN SECTION TO CAMP CREEK BRIDGE

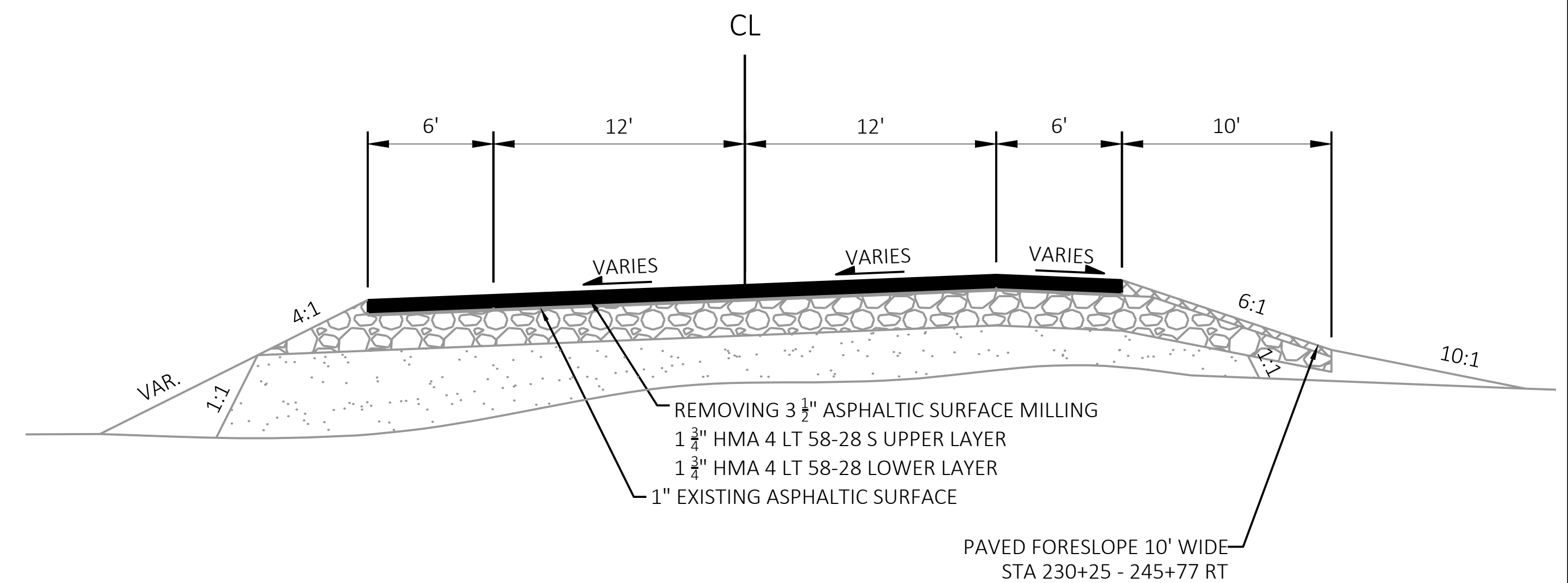

FINISHED TYPICAL SECTION

URBAN SECTION TO CAMP CREEK BRIDGE

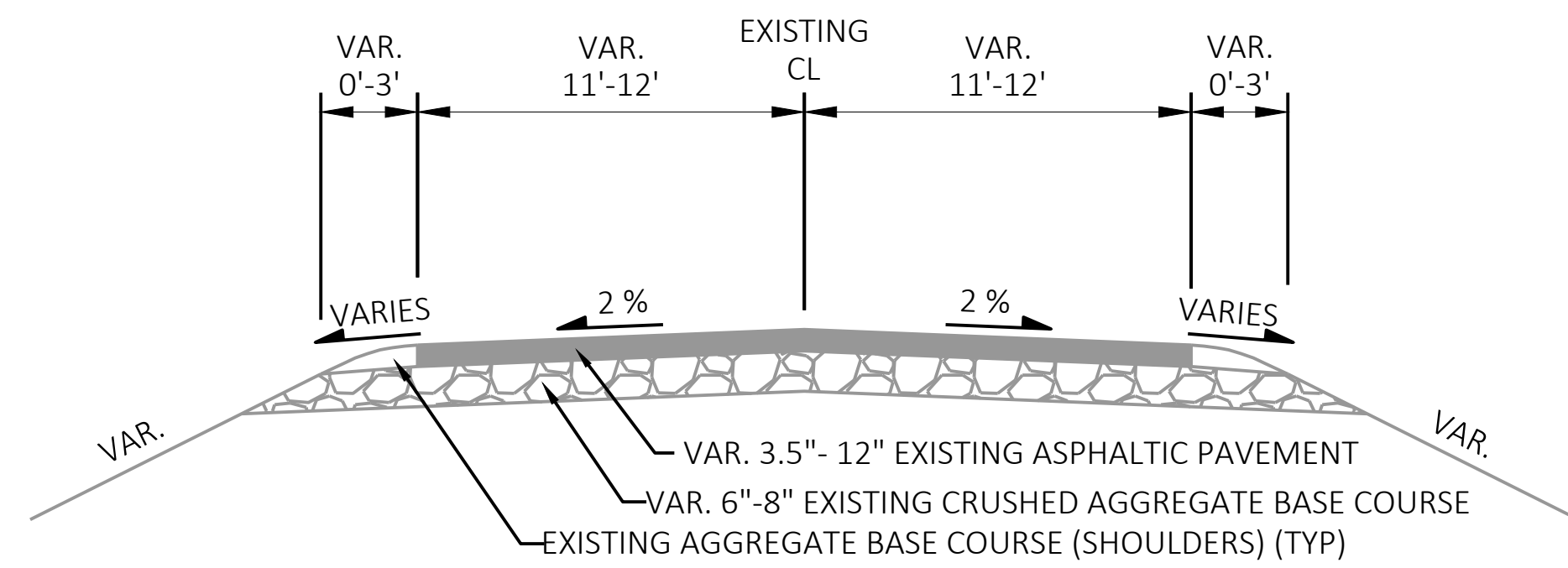

EXISTING TYPICAL RURAL SECTION

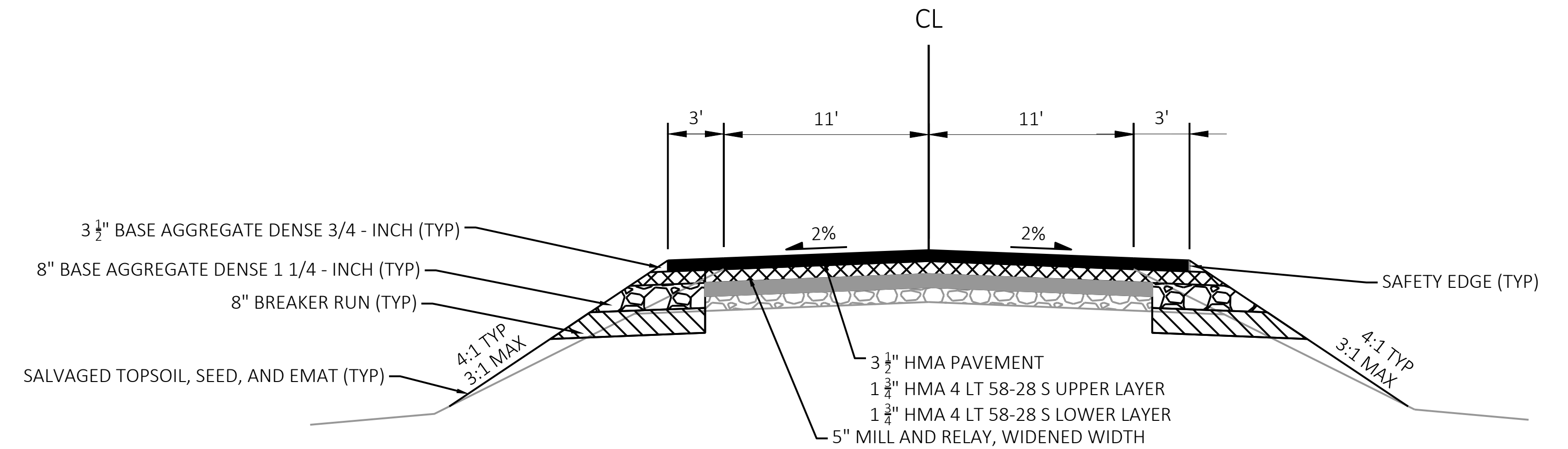

FINISHED RURAL TYPICAL SECTION

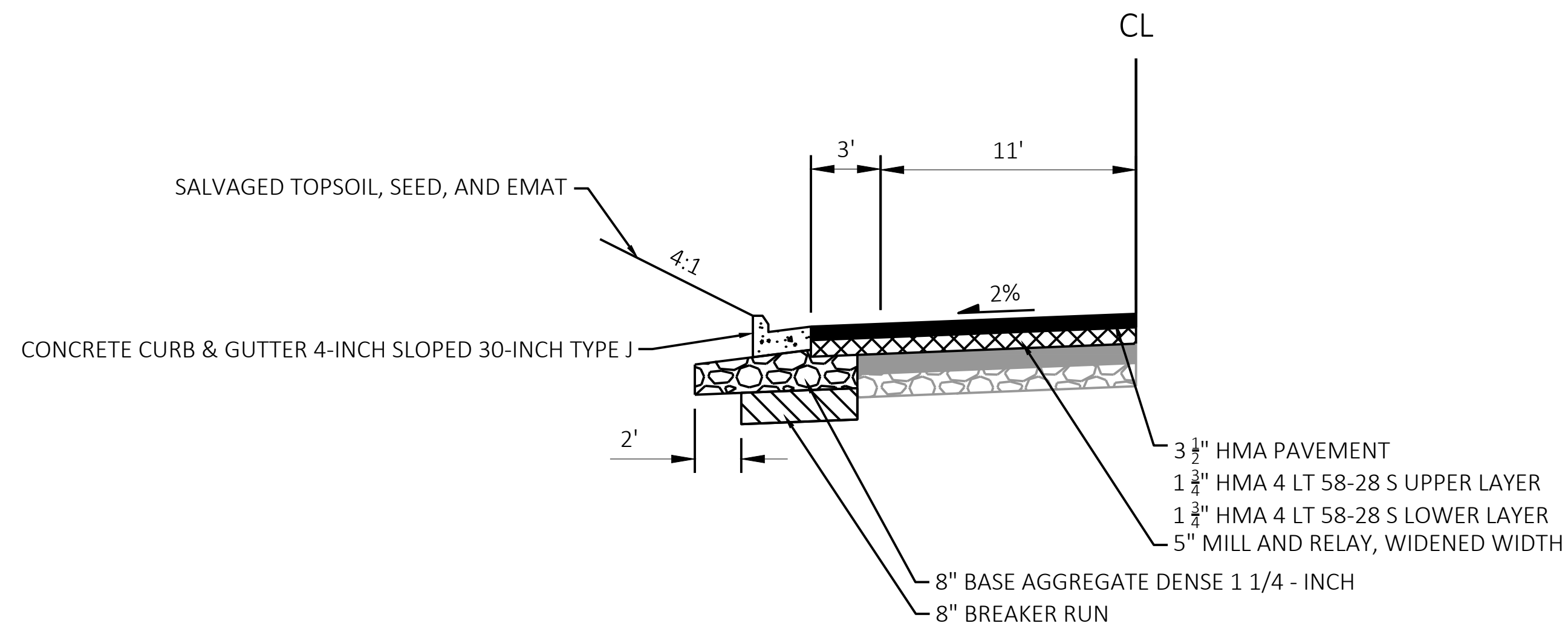

HALF FINISHED RURAL TYPICAL SECTION WITH CURB & GUTTER

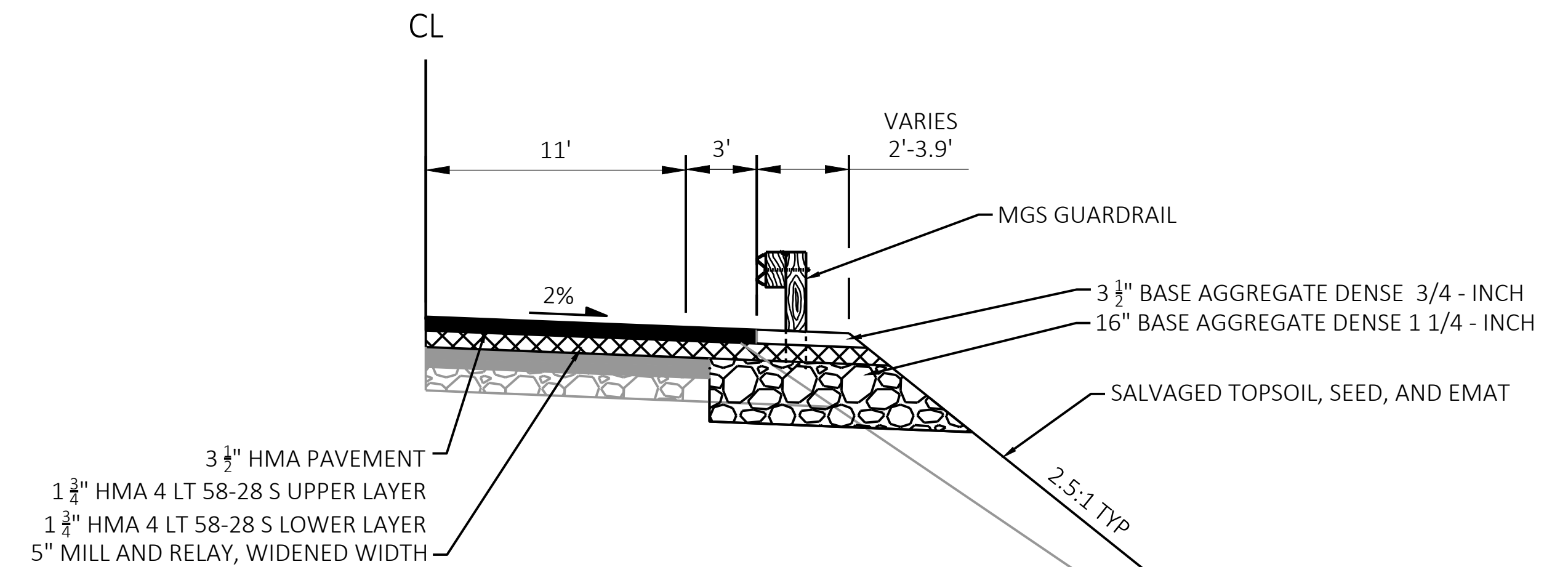

HALF FINISHED RURAL TYPICAL SECTION WITH GUARDRAIL

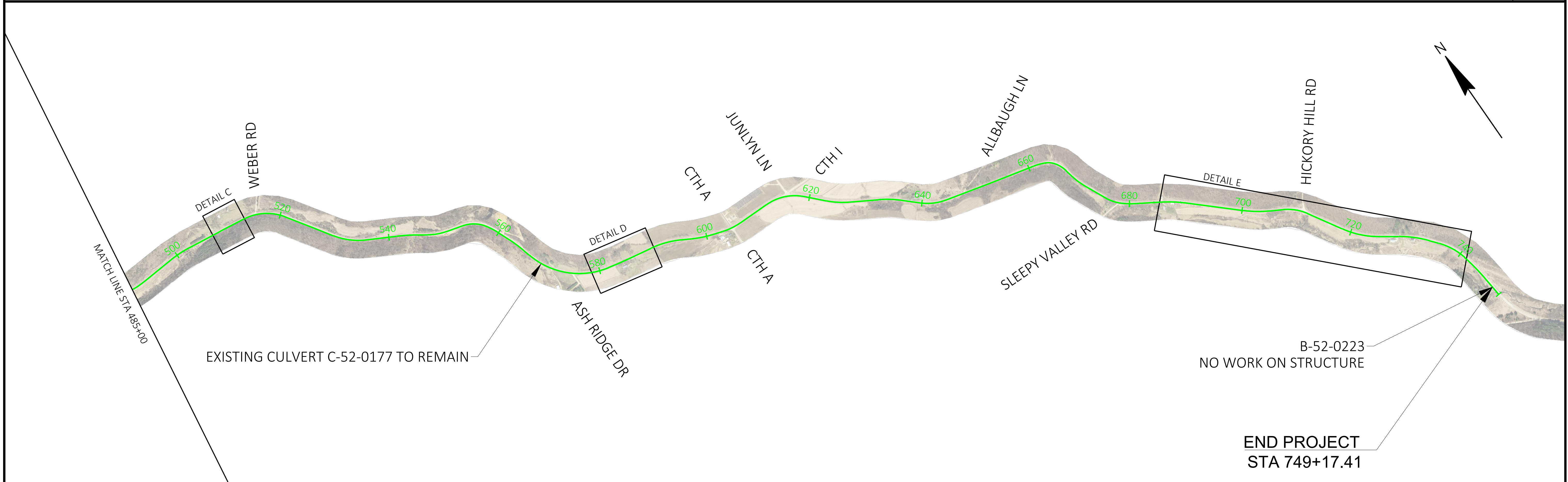
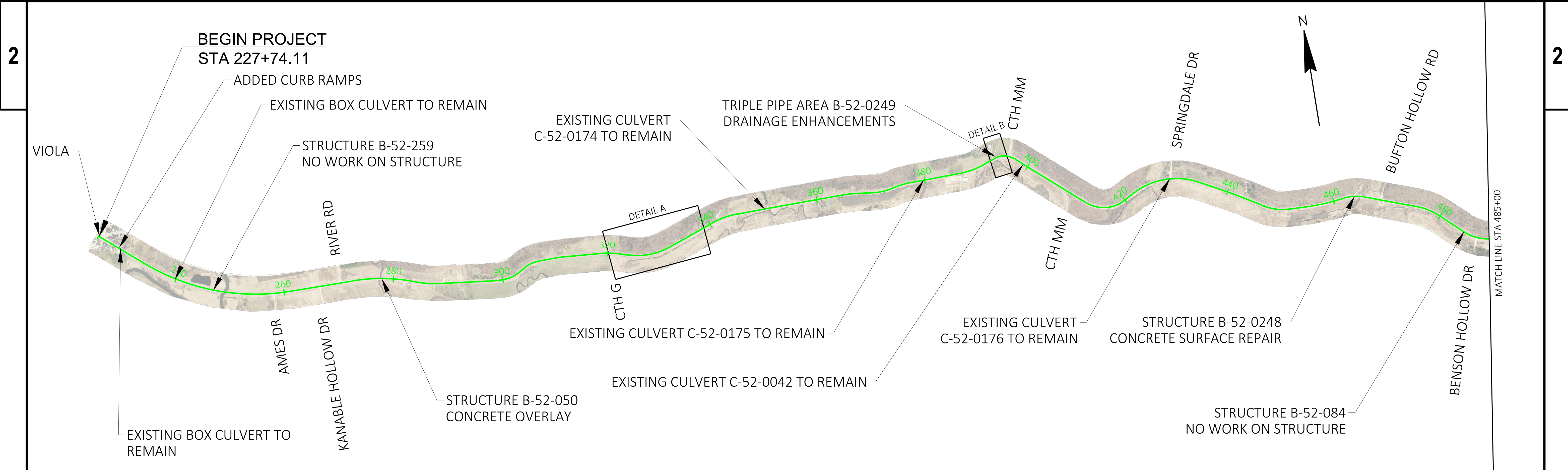

PROJECT NO: 5730-00-34	HWY: STH 56	COUNTY: RICHLAND	PROJECT OVERVIEW	SHEET	E
------------------------	-------------	------------------	------------------	-------	----------

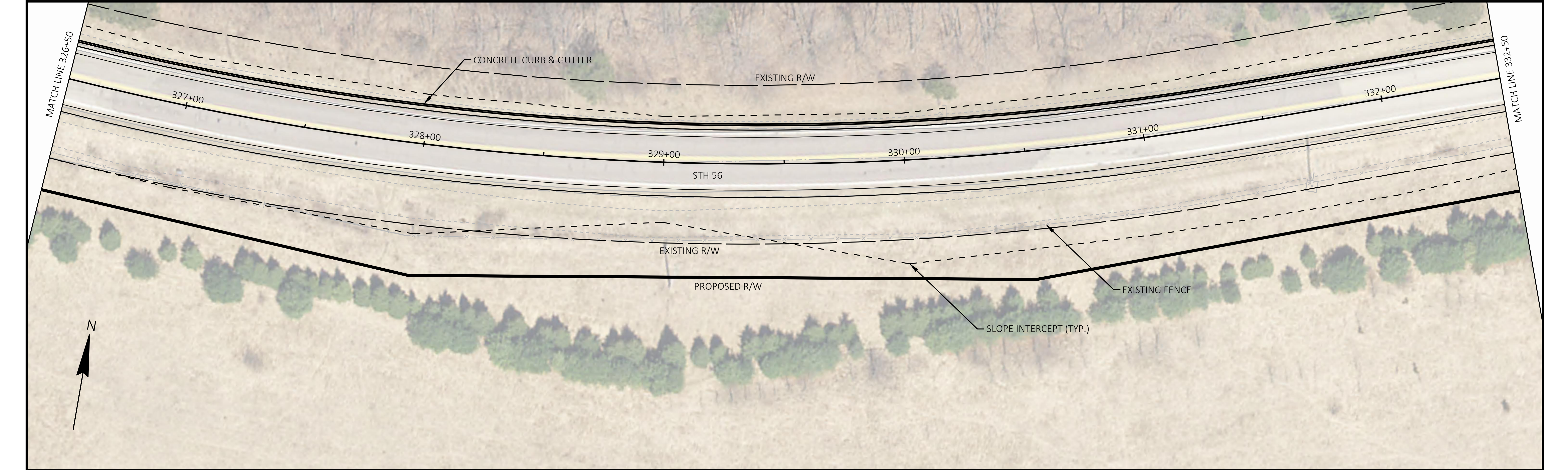
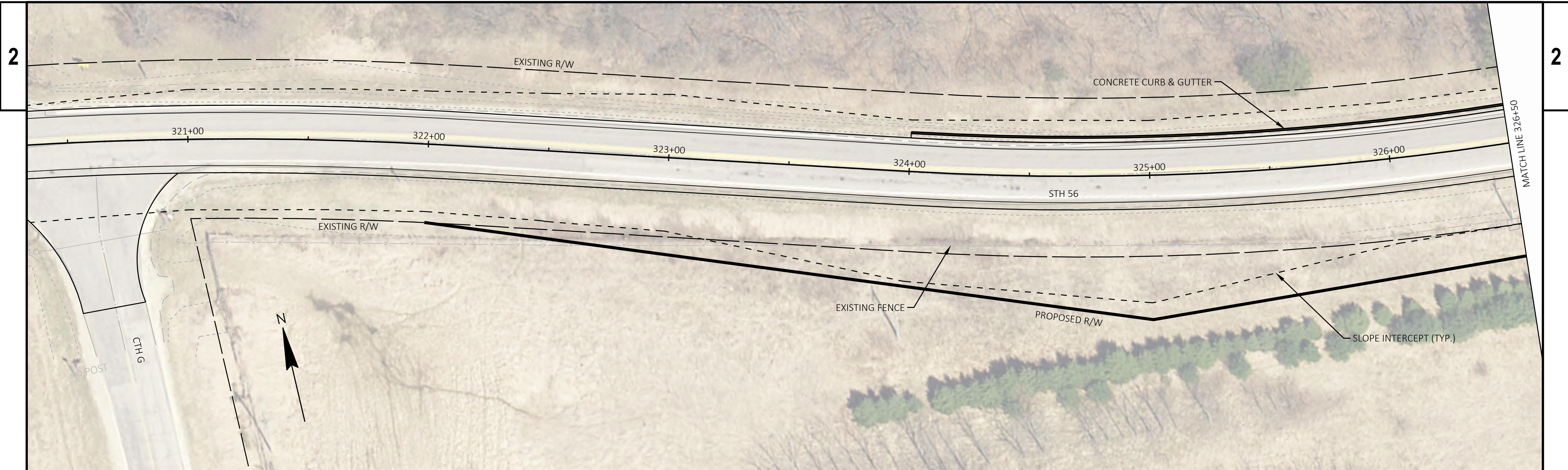

PROJECT NO: 5730-00-34	HWY: STH 56	COUNTY: RICHLAND	DETAIL A	SHEET	E
------------------------	-------------	------------------	----------	-------	----------

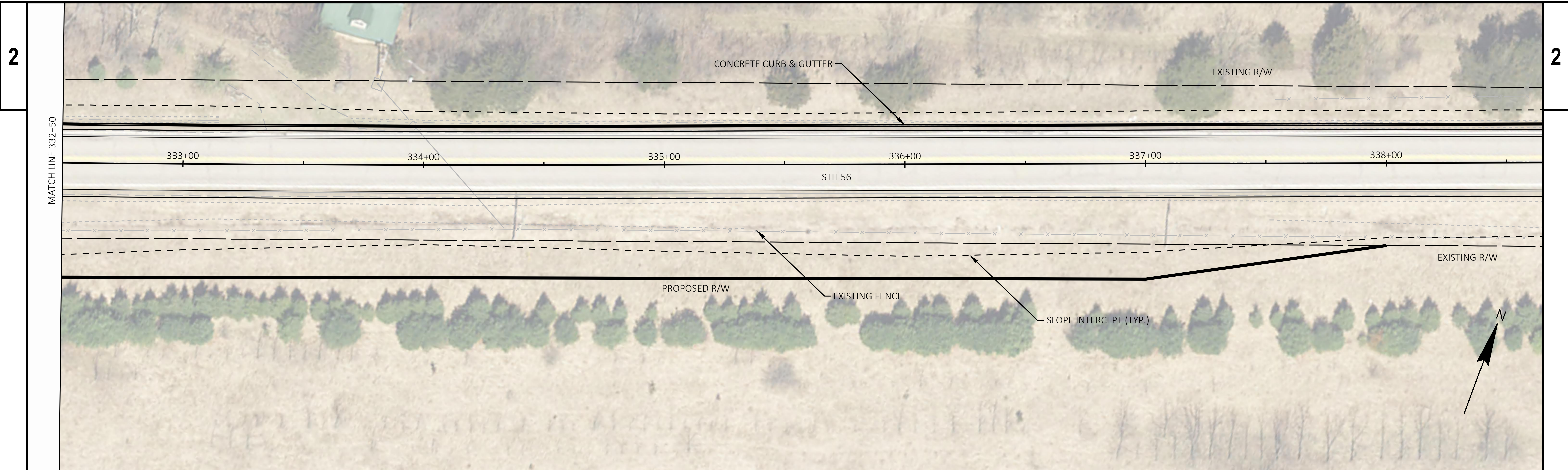

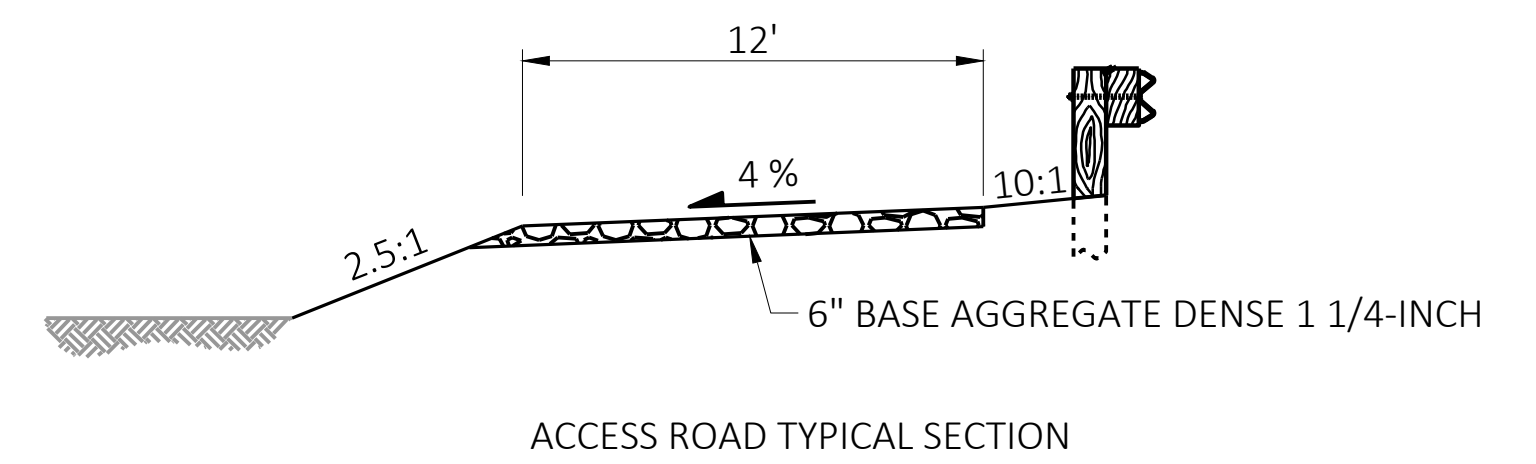
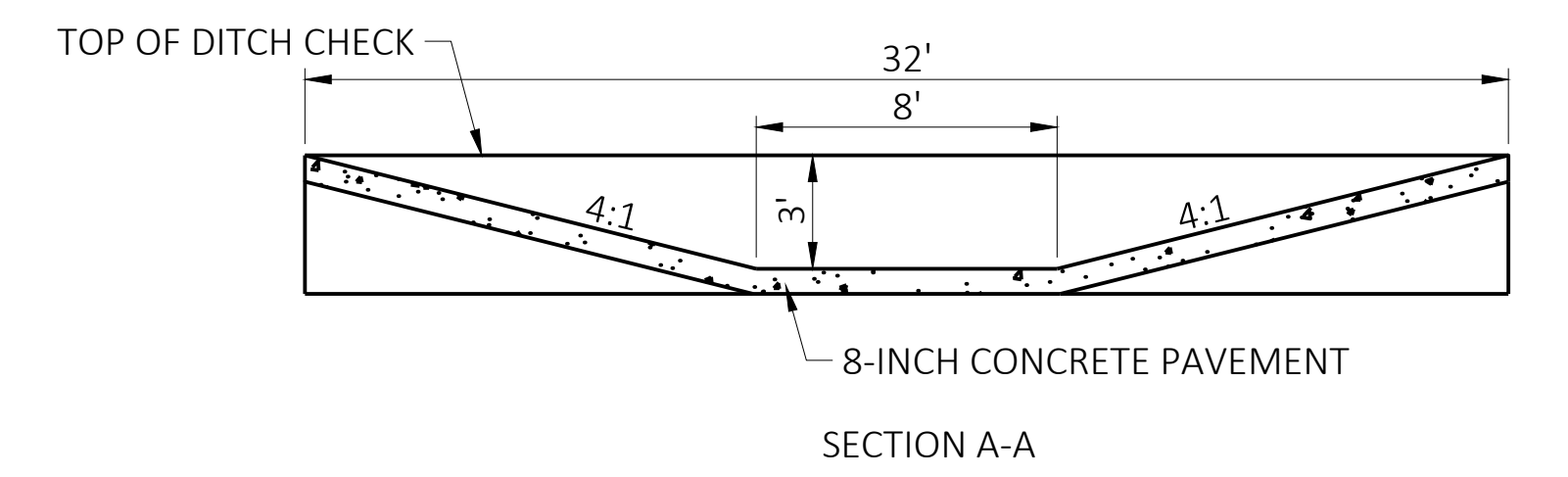
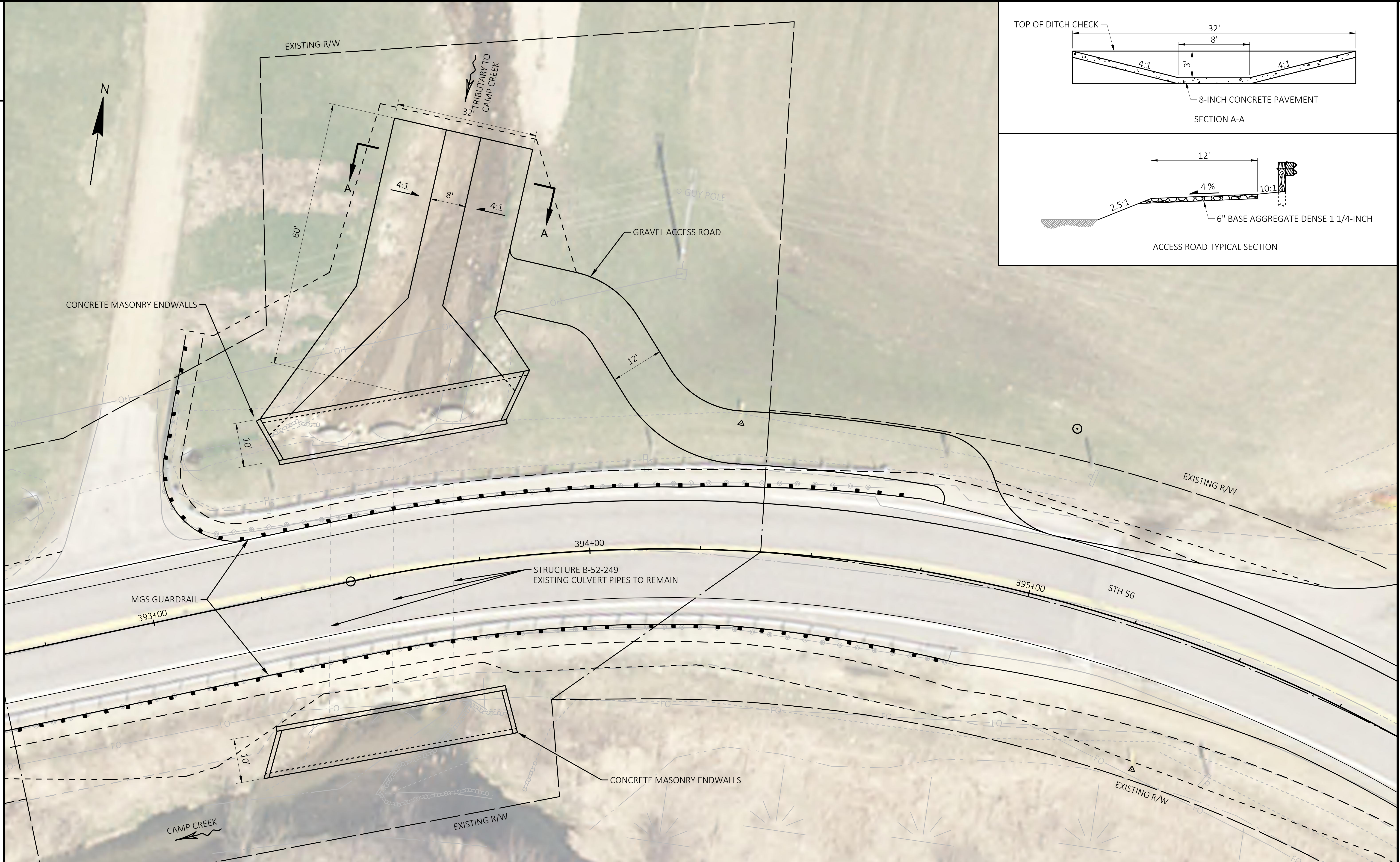



PROJECT NO: 5730-00-34	HWY: STH 56	COUNTY: RICHLAND	DETAIL C	SHEET	E
------------------------	-------------	------------------	----------	-------	----------

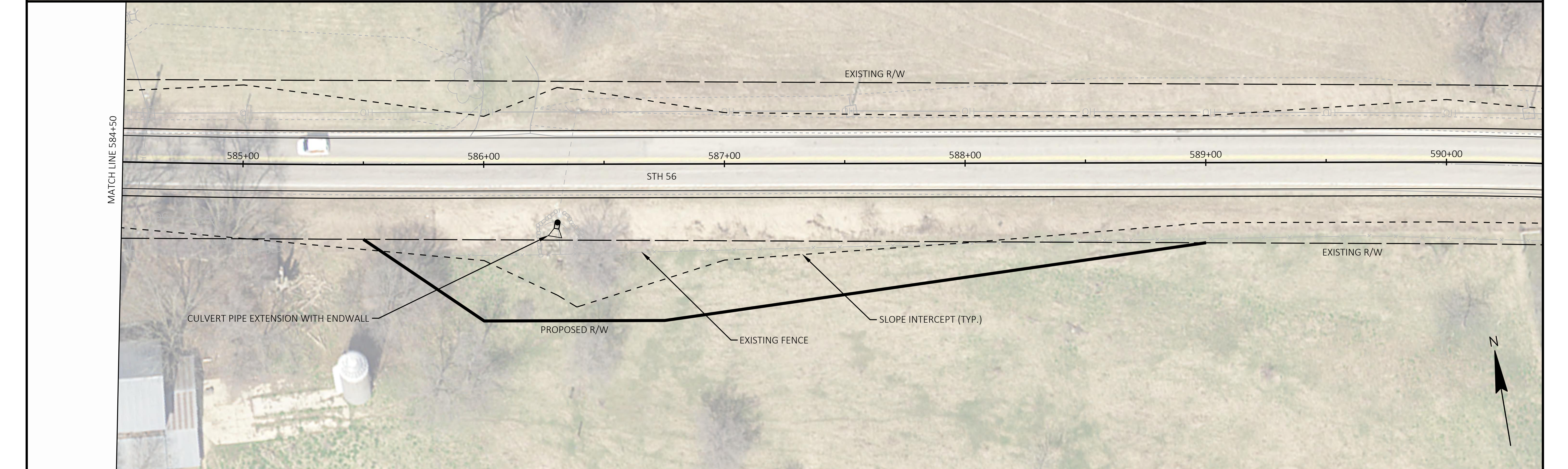
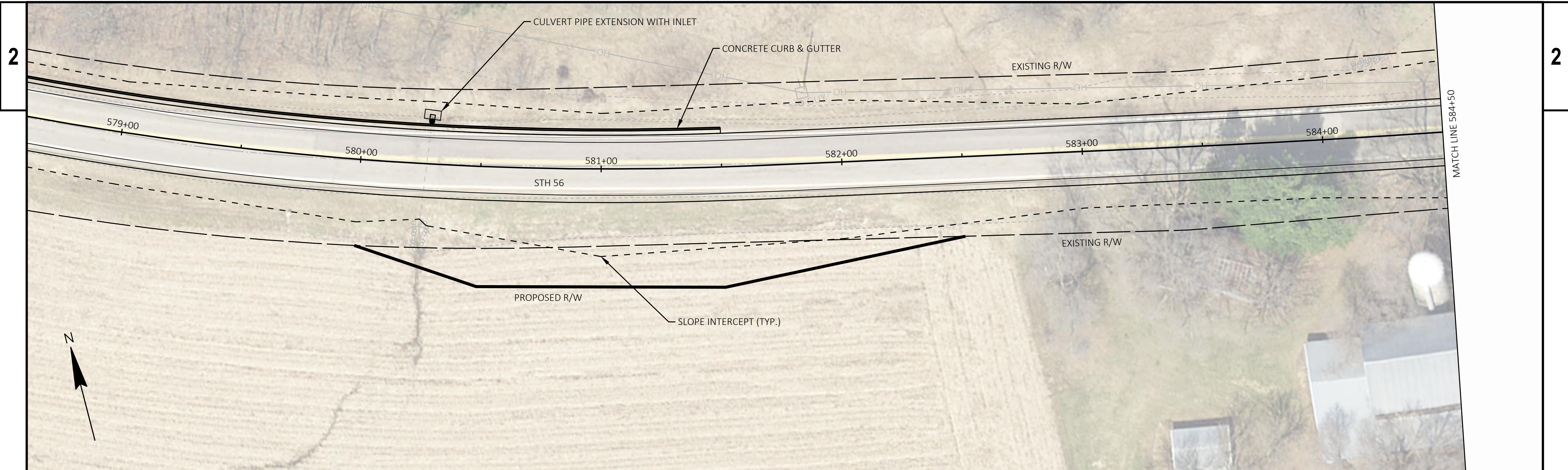

PROJECT NO: 5730-00-34	HWY: STH 56	COUNTY: RICHLAND	DETAIL D	SHEET	E
------------------------	-------------	------------------	----------	-------	----------

FILE NAME : G:\00\00093\00093699\CADD\SHEETS\OTHR\PIM_BLOWUPS.DWG
 LAYOUT NAME - PRW-R-580-582_585-589_1

PLOT DATE : 10/23/2023 2:36 PM

PLOT BY : CONNOR GIRTEN

PLOT NAME :

PLOT SCALE : 1 IN:40 FT

WISDOT/CADD SHEET 44

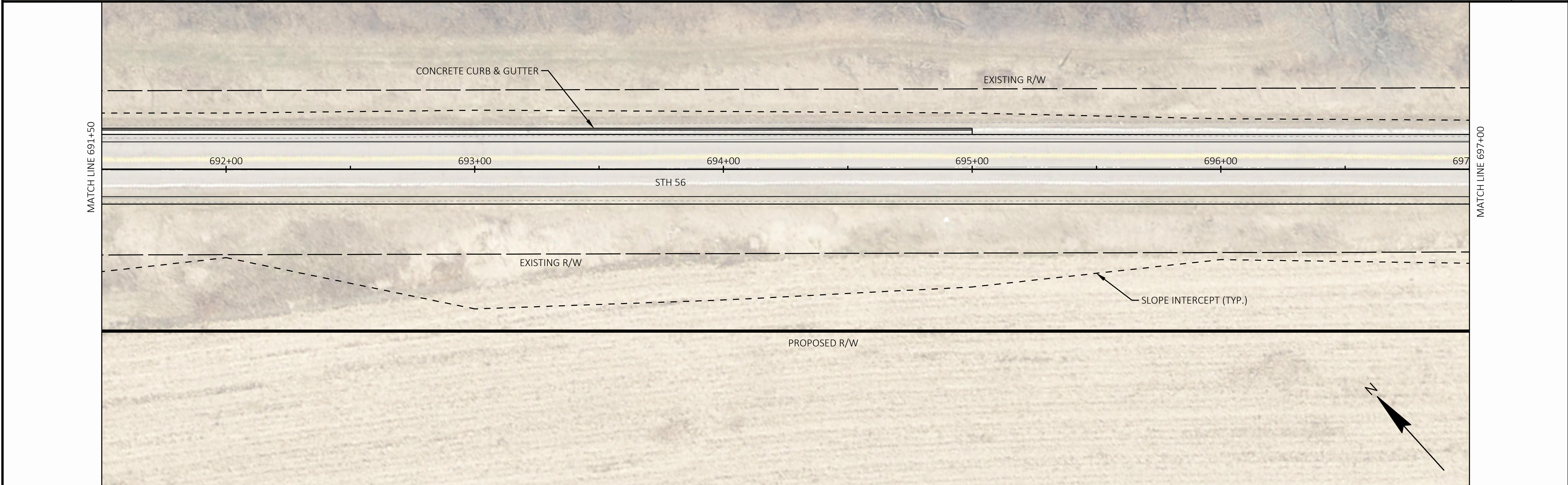
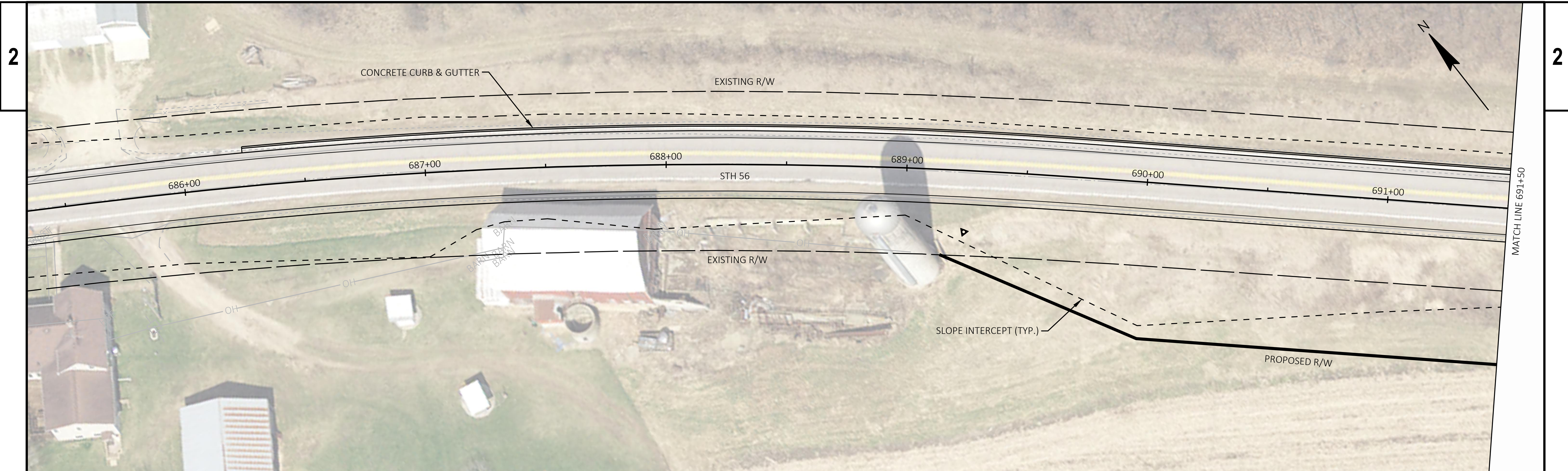

PROJECT NO: 5730-00-34	HWY: STH 56	COUNTY: RICHLAND	DETAIL E	SHEET	E
------------------------	-------------	------------------	----------	-------	----------

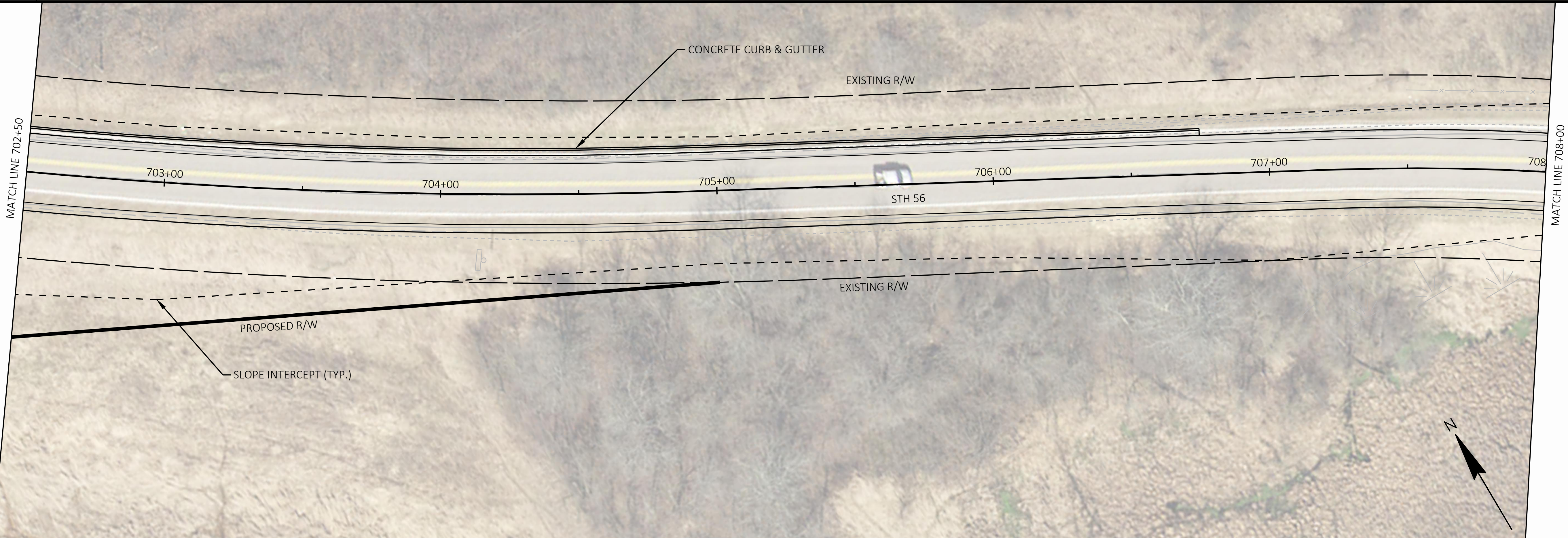
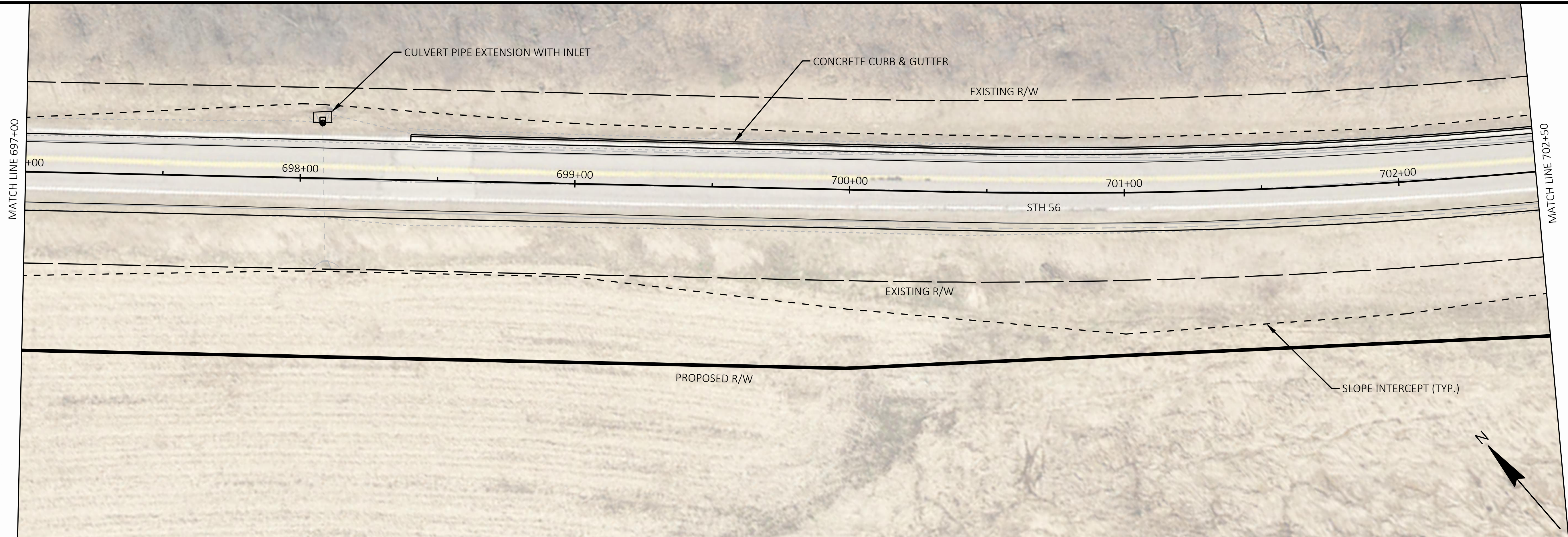

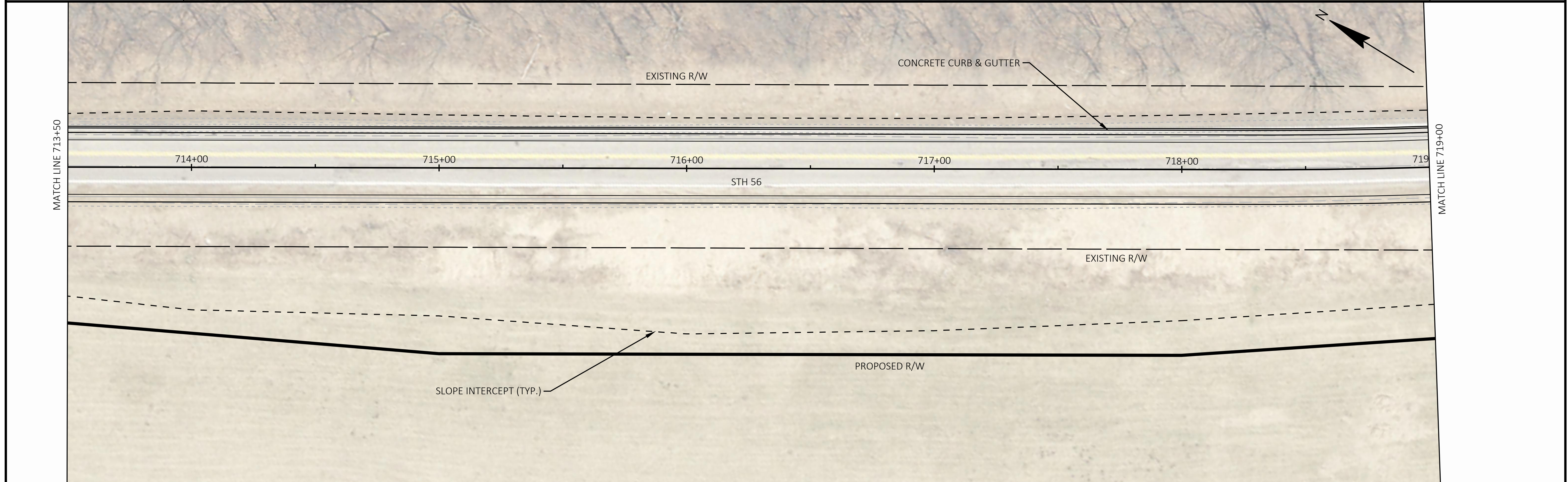
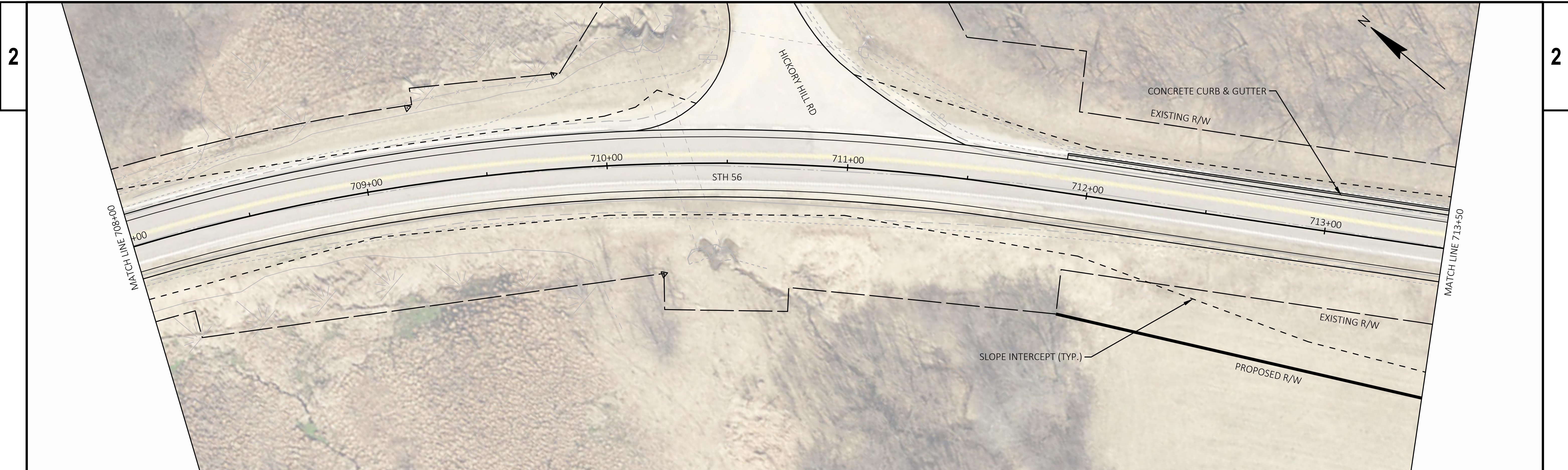

PROJECT NO: 5730-00-34	HWY: STH 56	COUNTY: RICHLAND	DETAIL E	SHEET	E
------------------------	-------------	------------------	----------	-------	----------

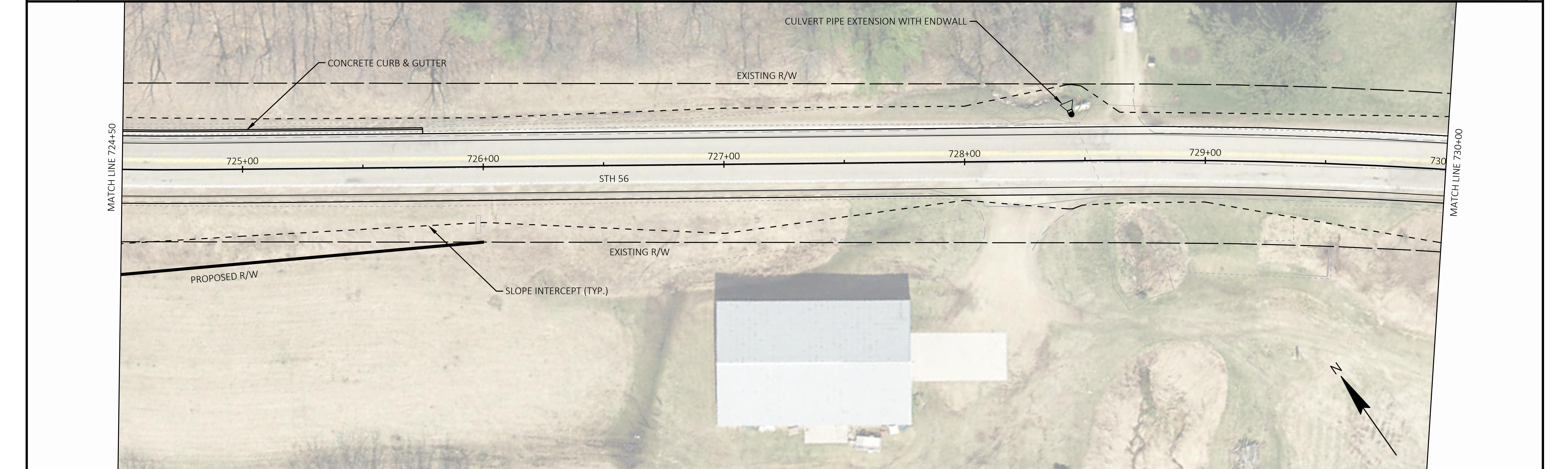
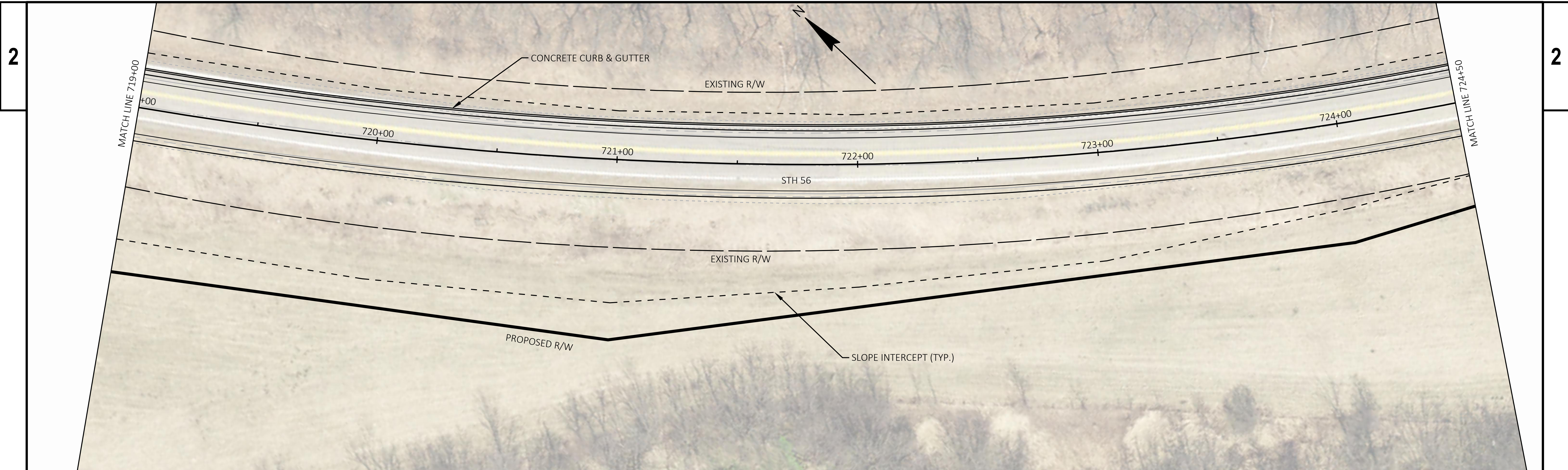

PROJECT NO: 5730-00-34	HWY: STH 56	COUNTY: RICHLAND	DETAIL E	SHEET	E
------------------------	-------------	------------------	----------	-------	----------

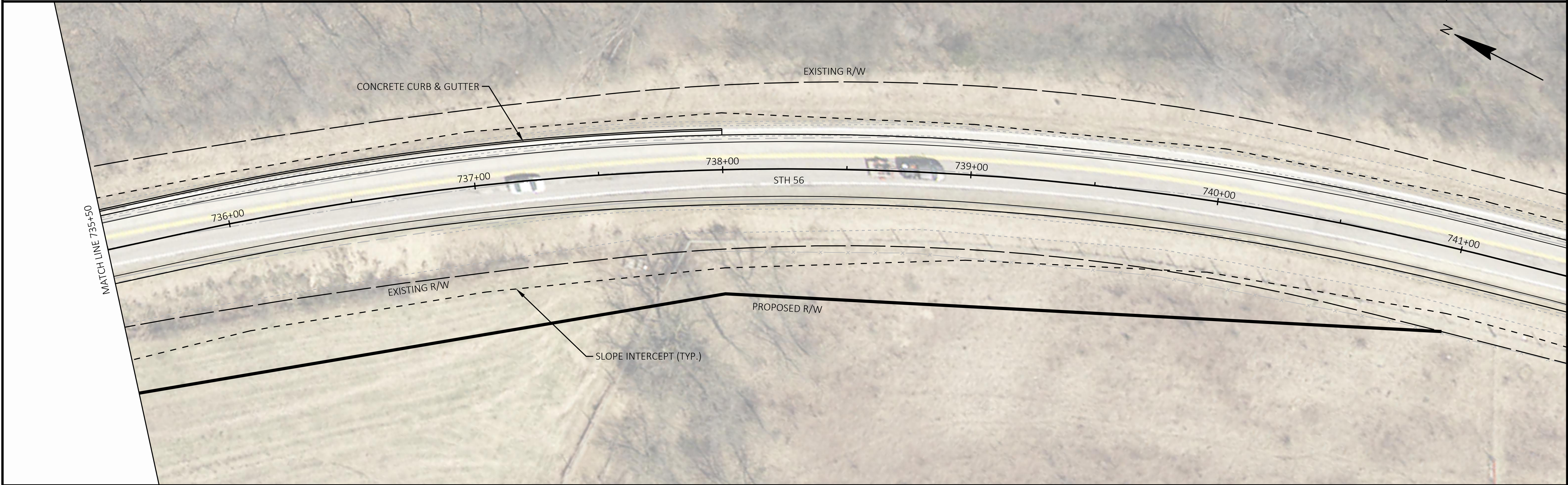
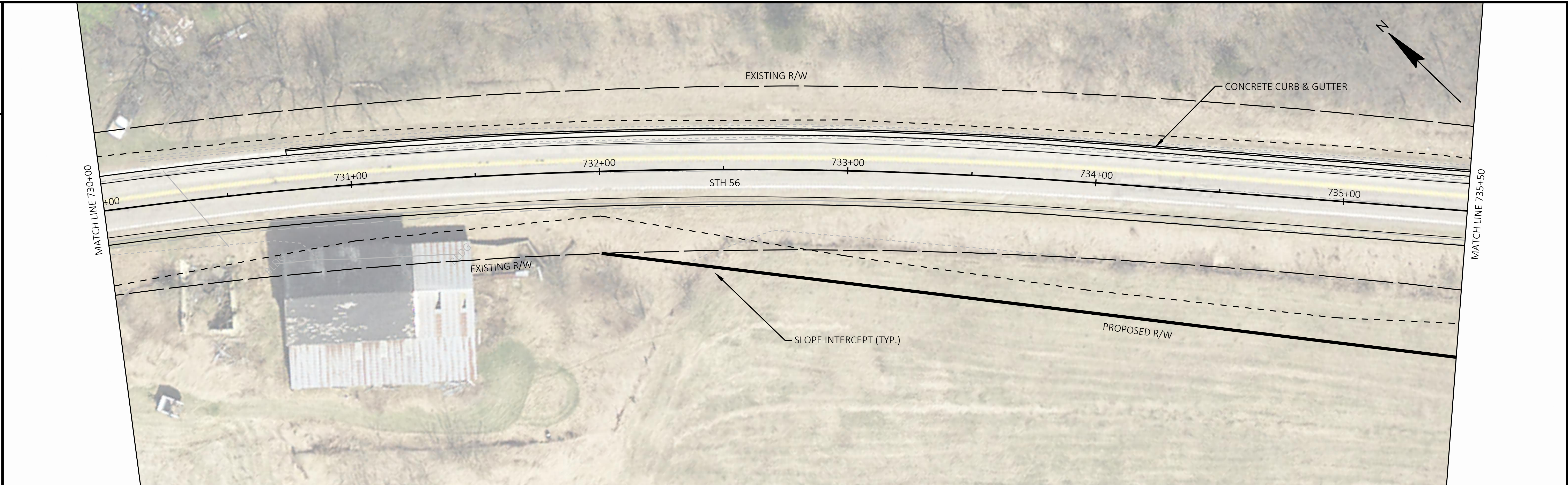

PROJECT NO: 5730-00-34	HWY: STH 56	COUNTY: RICHLAND	DETAIL E	SHEET	E
------------------------	-------------	------------------	----------	-------	----------