



Table of Contents

2.4 Superstructure..... 3

2.4.1 Introduction 3

2.4.2 Reinforced Concrete Structures 5

 2.4.2.1 Reinforced Concrete Slab (Element 38) 9

 2.4.2.2 Reinforced Concrete Closed Web/Box Girder (Element 105) Reinforced Concrete Open Girder (Element 110) Reinforced Concrete Stringer (Element 116) Reinforced Concrete Floor Beam (Element 155)..... 10

 2.4.2.3 Reinforced Concrete Arch (Element 144)..... 16

2.4.3 Prestressed Concrete Structures 22

 2.4.3.1 Prestressed Concrete Closed Web/Box Girder (Element 104) Prestressed Concrete Open Girder (Element 109) Prestressed Concrete Stringer (Element 115) Prestressed Concrete Floor Beam (Element 154)..... 26

 2.4.3.2 Prestressed Concrete Arch (Element 143) 33

2.4.4 Steel Structures..... 38

 2.4.4.1 Steel Closed Web/Box Girder (Element 102) Steel Open Girder/Beam (Element 107) Steel Stringer (Element 113) Steel Floor Beam (Element 152) Steel Cross Girder – Closed Web/Box Girder (8102) Steel Cross Girder – Open Girder/Beam (8107) 45

 2.4.4.2 Steel Cable – Primary (Element 147) Steel Cable – Secondary (Element 148) 72

 2.4.4.3 Steel Tension Rods/Post-Tensioned Cables (Element 8165)..... 77

 2.4.4.4 Steel Truss (Element 120) 81

 2.4.4.5 Steel Gusset Plate (Element 162) 89

 2.4.4.6 Steel Arch (Element 141)..... 93

 2.4.4.7 Steel Pin or Pin and Hanger Assembly (Element 161) 98

 2.4.4.8 NSTM Steel Superstructure Inspection..... 105

2.4.5 Timber Structures..... 112

 2.4.5.1 Timber Open Girder (Element 111) Timber Stringer (Element 117) Floor Beam (Element 156), Timber Spreader Beam (Element 8166) 114

 2.4.5.2 Timber Truss (Element 135) 119

 2.4.5.3 Timber Arch (Element 146)..... 122

2.4.6 Masonry Structures 126

 2.4.6.1 Masonry Arch (Element 145) 126

2.4.7 Other Material Superstructures 129



2.4.7.1 Other Closed Web/Box Girder (Element 106) Other Open Girder (Element 112) Other Stringer (Element 118) Other Floor beam (Element 157)	129
2.4.7.2 Other Truss (Element 136)	132
2.4.7.3 Other Arch (Element 142)	135
2.4.7.4 Other Primary Structural Members (Element 8170)	139
2.4.8 Bearing Elements	142
2.4.8.1 Elastomeric Bearing (Element 310)	143
2.4.8.2 Movable Bearing (Element 311)	148
2.4.8.3 Fixed Bearing (Element 313)	161
2.4.8.4 Pot Bearing (Element 314)	164
2.4.8.5 Disk Bearing (Element 315)	168
2.4.8.6 Other Bearing (Element 316)	171
2.4.9 Superstructure NBI Condition Ratings	173



2.4 SUPERSTRUCTURE

2.4.1 Introduction

The term “superstructure” is defined as all bridge elements above the substructure units. However, for bridge inspection purposes, “superstructure” refers to all bridge elements, other than the deck, that distribute loads longitudinally to the substructure units. The exception to this definition is the concrete slab, where the deck and superstructure are one and the same.

Members comprising the superstructure are categorized into two groups: primary and secondary. Primary superstructure members are those that directly carry the deck dead loads and live loads to the abutments and piers. The superstructure members include girders, beams, floor beams, stringers, arches, trusses, cables, bearings, and stiffeners. Secondary superstructure members are those that do not directly carry deck dead loads and live loads. The secondary superstructure members are used to provide lateral stability for the primary members and help laterally distribute the live loads so that the individual primary members act together as a unit. Secondary members include diaphragms, cross-frames, struts, and lateral bracing.

Superstructures come in a variety of types and configurations and comprised of concrete, steel, timber, a combination of materials, or another material entirely. Retrofits or repairs may see use of a differing structural material than the existing. This may be due to availability, cost, geometric or installation restrictions. For instance, a fractured timber stringer may be retrofitted with a C-channel bolted to its side or a rolled beam may replace the stringer altogether.

It is necessary for the inspector to understand the components of the superstructure and their function within the load path. The bridge inspector must understand the critical areas of each type of superstructure as well as the defects associated with the structural material the component is comprised of.

This chapter is broken down by construction material (concrete, steel, timber, etc.) and superstructure type (girder, truss, arch, etc.). Each material section lists the elements in numerical order (as they are labeled in the AASHTO Manual for Bridge Element Inspection) and describes the element in detail. Each element segment of the chapter details the element level inspection and safety inspection to further guide the inspector.

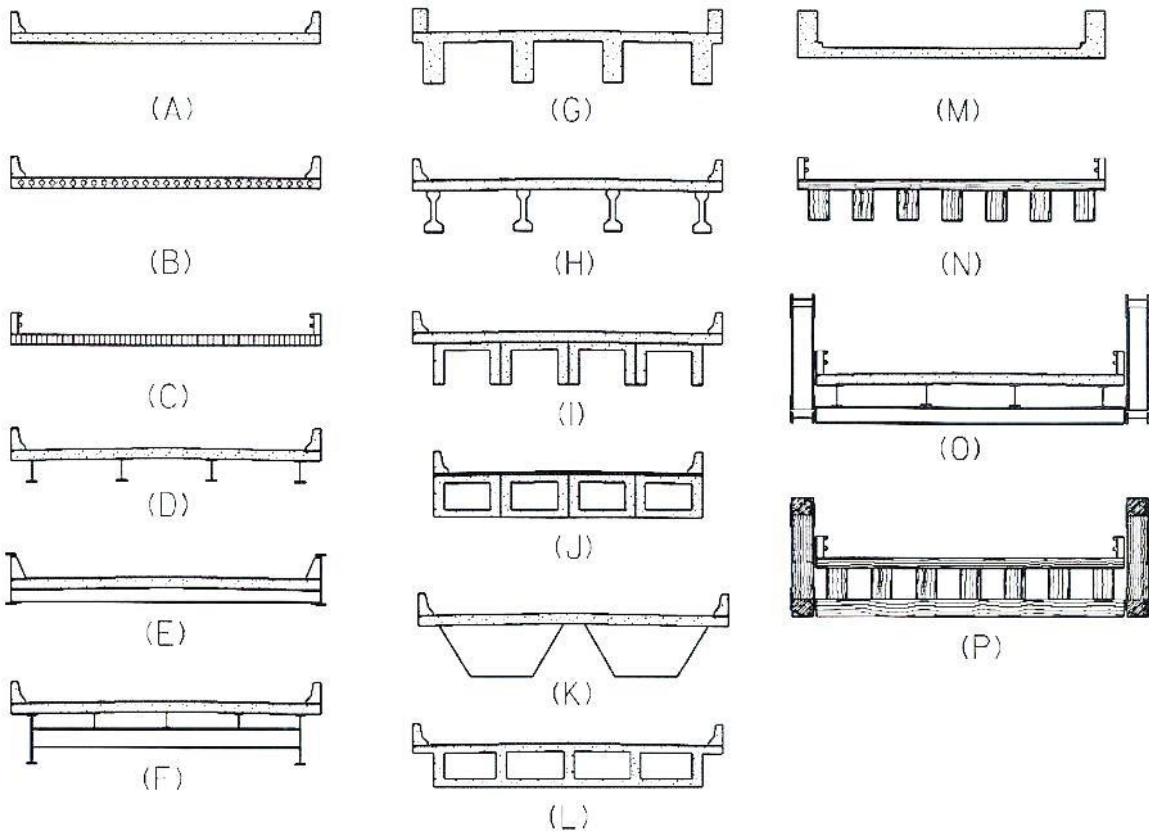

Figure 2.4.1-1: Common Superstructure Types – (A) Reinforced Concrete Flat Slab; (B) Reinforced Concrete Voids Slab; (C) Timber Slab; (D) Steel Multi-beam; (E) Steel Through Girder; (F) Steel Girder/Floor Beam/Stringer; (G) Reinforced Concrete Tee Beam; (H) Prestressed Concrete I Beam; (I) Prestressed Concrete Channel; (J) Prestressed Concrete Box Beam; (K) Steel Box Girder; (L) Post-tensioned Concrete Box Girder; (M) Reinforced Concrete Through Girder; (N) Timber Multi-beam; (O) Steel Truss; (P) Timber Truss.

Primary superstructure members must carry repetitive live loads, as well as repeatedly applied impact loads. Depending on the type of superstructure, the members may need to deliver these loads to the substructure by way of bending, tension, compression or a combination of these. To handle this type of demand, it is critical that the members be sound, as failure of one, in the worst case, could be catastrophic. This chapter provides guidelines for the bridge inspector on which parts of the superstructure are critical to inspect and what defects may cause future problems.

2.4.2 Reinforced Concrete Structures

Concrete has been used to construct bridges in the United States since 1889. With the exception of arches, conventional reinforced concrete was initially limited to short single span use. The development of prestressed concrete in the middle part of the 1900s, with the subsequent development of post-tensioned concrete boxes, allowed concrete to gain acceptance for use on medium and long span bridges. Concrete can be configured in many different ways, including:

1. **Cast-in-place slabs:** Cast-in-place slab bridges are the simplest type of concrete bridge. The slab acts as a single, wide beam spanning from substructure unit to substructure unit. There are no individual beams with this type of bridge, and the slab also acts as the deck. Slabs are used for simple spans of about 45 feet or less. Continuous slab bridges can be built with slightly longer span lengths. To attain greater negative bending strength on continuous bridges, the slab may be thickened (haunched) over the piers. The main reinforcing steel is placed parallel to traffic and located towards the bottom of the slab in positive bending regions, and towards the top of the slab in negative bending regions. On older and more complex structures, continuous cast-in-place slabs may contain voids to lighten the dead load of the bridge. Refer to Chapter 3 for more information on slab structures.



Figure 2.4.2-1: Single Span Flat Slab Bridge.

2. **Tee beams:** Tee beam bridges were commonly constructed in the early half of the 20th century. They are cast-in-place structures, with the deck cast monolithic with the beams. The “tee” shape is created by the rectangular beam stem below the deck, with the deck forming the top flange. In Wisconsin, the fascia beams on many tee beam bridges are upturned, doubling as parapets. Tee beam bridges are most commonly used for simple spans, although they may be made continuous by adding a haunch the beam stems over the piers. Individual spans may reach 50 feet in length, with the beams spaced from about 3 to 8 feet. Common beam depths range from 18 to 24 inches. The main reinforcing steel is placed longitudinally towards the bottom of the beam in positive bending regions and longitudinally within the deck in

negative bending regions. Transverse, vertical stirrups placed along the beams serve as shear reinforcing.



Figure 2.4.3-2: Reinforced Concrete Tee Beam Bridge.

- Through girders:** Through girder bridges were constructed in the early half of the 20th century. They are cast-in-place structures, with the deck cast monolithic with the girders. Two girders normally are used, and these very deep girders serve as the primary superstructure, as well as bridge parapets. The deck spans between the girders, connected to the lower portion of the girders. Through girder bridges are used for simple spans of 30 to 60 feet. Because the deck must span between the girders, through girder bridge widths rarely exceed 24 feet. The girders themselves are fairly large, being 18 to 30 inches wide and 4 to 6 feet deep. The main reinforcing steel is placed longitudinally towards the bottom of the girders, while the main deck reinforcing steel is placed transversely towards the deck bottom. Transverse, vertical stirrups placed along the girders serve as shear reinforcing.



Figure 2.4.3-3: Reinforced Concrete Through Girder Bridge.

- Channel beams:** Channel beam bridges use precast channel beams as the primary load-carrying members. The channels are placed on the substructure units so that they form an upside down “U”, with the vertical legs forming the beams and the horizontal top slab forming the deck. The channels are placed tight side by side and transversely connected so that the individual beams act as a unit under live loads. Grouted shear keys also help the beams to act together. Channel beam bridges are used for simple spans up to about 50 feet. Widths of the individual beams usually range from 3 to 4 feet. The main reinforcing steel is placed longitudinally towards the bottom of the channel legs, while the main deck reinforcing steel is placed transversely in the top slab. Vertical stirrups may be placed along the channel legs and serve as shear reinforcing.



Figure 2.4.3-4: Deteriorated Prestressed Channel Beams.

- Open spandrel arches:** Open spandrel arch bridges use either cast-in-place arch ribs or a single arch ring as the primary load-carrying members. The arches resist a combination of axial compression and bending moments. The deck and floor system are placed above the arches, and spandrel columns and caps (bents) deliver these loads to the arch. The space between the deck and arch (the spandrel) is left open, hence the name “open spandrel arch”. Since the arch acts primarily as a compression member, longitudinal steel is uniformly distributed around its perimeter, contained by transverse ties. The spandrel bent columns are reinforced in a similar manner. Spandrel bent caps act as fixed end beams, so reinforcing steel is placed near the bottom between the columns and near the top above the columns. Transverse, vertical stirrups placed along the cap serve as shear reinforcing. The deck and floor system loading the spandrel arches are designed and reinforced similar to other reinforced concrete beams.



Figure 2.4.3-5: Open Spandrel Reinforced Concrete Arch.

- 6. Closed spandrel arches:** Closed spandrel (“Earth Filled”) arch bridges use a single cast-in-place arch ring or barrel, as the primary load-carrying member, with the arch resisting a combination of axial compression and bending moments. The spandrel area is closed by solid walls built above the barrel edges, hence the name “closed spandrel arch”. The deck/roadway is always placed above the arches, and the spandrel area may be filled or vaulted. In filled spandrels, the roadway pavement bears on fill material that occupies the spandrel area. This fill is contained by solid spandrel walls built above the barrel edges. Main reinforcing steel for solid spandrel walls retaining fill is placed at the back or fill side of the wall and cannot be inspected. In vaulted spandrels, the structural deck and floor system load the arch by way of transverse spandrel walls or spandrel bents, while the spandrel walls are nonstructural. The spandrel bents, deck, and floor system are reinforced similar to open spandrel arches. Arch barrels are reinforced with longitudinal steel uniformly distributed around its perimeter, contained by transverse ties. The top side of the barrel cannot be inspected, unless access is provided in vaulted closed spandrel arch bridges.

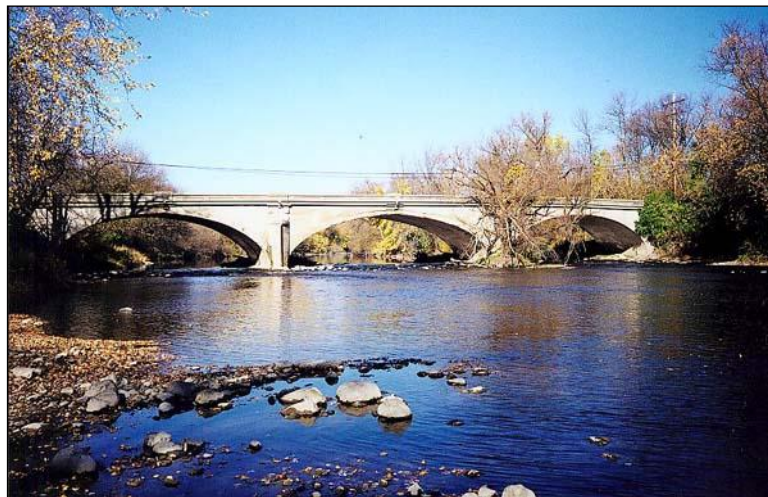

Figure 2.4.3-6: Closed Spandrel Concrete Arches.

7. **Rigid frames:** Rigid frame bridges are structures in which the vertical or inclined supporting “legs” are cast monolithically with the girders to form a rigid frame. These bridges are usually single span structures constructed to form an inverted channel, usually of a slab design. Multiple span bridges may also be constructed by forming a rectangular shape, a “K” shape or a triangular delta shape. Though the legs are used as bridge piers, the vertical or inclined legs are actually part of the superstructure because of their rigid connection to the horizontal slab or girders. This rigid intersection of the leg and horizontal member is referred to as the knee and allows both members to resist bending moments. Main reinforcing steel in the horizontal members is placed longitudinally near the bottom of the slab or girder between the abutments and legs. At the knees, it is placed longitudinally near the top on continuous bridges and around the outside or the corner on single span bridges. Main reinforcing steel is placed vertically on both frame leg faces on continuous bridges and only on the traffic face of single span bridges. Transverse, vertical stirrups placed along the horizontal member of beam frames serve as shear reinforcing, while transverse ties are placed along the legs. Spans of 50 to 200 feet are attainable using rigid frames.



Figure 2.4.3- 7: Single Span Concrete Rigid Frame

2.4.2.1 Reinforced Concrete Slab (Element 38)

These elements represent the simplest concrete superstructures and have been in use for many years. Concrete slab elements are currently the most economical method to span short distances. Slab elements are most commonly constructed using cast-in-place methods, although plant fabricated precast/prestressed or post-tensioned hollow core planks have also been used to create slab bridges. Precast slabs are different than precast box beams in that precast slabs contain two or more voids through them, while box beams have only one.

Refer to Part 2 – Chapter 3 Decks and Slabs for description and element level inspection methods for reinforced and prestressed concrete slabs.

Elements in this section are mostly field cast, though some may be non-prestressed plant cast members. All are strengthened with conventional mild reinforcing steel.

2.4.2.2 Reinforced Concrete Closed Web/Box Girder (Element 105)
Reinforced Concrete Open Girder (Element 110)
Reinforced Concrete Stringer (Element 116)
Reinforced Concrete Floor Beam (Element 155)

These are primary bending elements of conventionally reinforced concrete bridges. Closed web/box girders and open girders are longitudinal main members spanning between substructure units. They may sometimes be referred to as beams rather than girders. Stringers are small longitudinal members that span between the floor beams. Floor beams, in turn, span transversely between the main longitudinal girders.

These bending elements are normally rectangular or “tee”-shaped members. On tee-shaped beams, the top flange also functions as the bridge deck. The cross-section of a reinforced concrete closed web/box girder will normally contain several cells, rather than forming a single box shape. These bridge types may be thought of as a series of “I”-shaped girders lined up side-by-side. As with tee beams, the top flanges of box girders function as the bridge deck.



Figure 2.4.2.2-1: Inside of a Reinforced Concrete Box Girder.

Since each of these elements are conventionally reinforced bending members, the inspector should expect to find transverse flexural cracks on the top or bottom surfaces in the high moment areas. The main reinforcing steel for concrete bending members is placed longitudinally near the tension surface. Diagonal shear cracks on the sides of these elements may also be found at the abutments and piers. To provide shear strength, vertically oriented reinforcing steel ties are placed along the length of these elements.



Element Level Inspection

These elements define all reinforced concrete beam elements regardless of the wearing surface or protective systems used.

On the inspection report form, reinforced concrete girders, stringers, and floor beams are recorded in units of lineal feet. The correct method for calculating the girder/beam length is multiplying the number of beams in each span times the span length of each span. Where multiple condition states exist within a unit of measure only the predominant defect in severity and extent is recorded. The other defects located within the unit of measure shall be captured by the inspector under the element or appropriate defect notes. The sum of all of the reported condition states must equal the total quantity of the element. This will quantify the element's condition and help generate quantity/cost estimates for future remedial work.

For box girders or other beams where traffic drives directly on the top flange, regardless of wearing surface, the top flange, above the fillet, shall be assessed as element 16 Reinforced Concrete Top Flange. The remaining portion of the beam shall be evaluated under the appropriate superstructure element. Refer to Chapter 3 of Part 2 for more information on deck and top flange elements and their associated material defects.

Element Level Inspection of reinforced concrete closed web/box girders, open girders, stringers, and floor beams should include the following items:

- Inspecting the member for cracks. The inspector should look for transverse flexural cracks on the underside of the beam between supports and on top of the deck over the piers on continuously supported bridges. Cracks wider than hairline in the flexural region of beams may indicate a serious structural overload.
- Checking for deteriorated concrete in the flexural zones that is causing debonding of the reinforcing steel. This is especially critical near the ends of the reinforcing steel bars, since a certain length of the bar must be embedded within sound concrete to fully develop its strength. The deterioration causing the debonding may be delaminations, spalls or longitudinal cracks.
- Examining the support areas for shear cracks. Shear cracks will be diagonal, extending up from the bearing towards mid-span. Wide shear cracks suggest the loss of aggregate interlock, meaning the member could be hanging from the reinforcing stirrups. Maximum crack widths should be measured and noted on the bridge inspection report.
- Checking the entire member for signs of corroding reinforcing steel, as indicated by rust stains or exposed reinforcement. Since section loss associated with reinforcing steel corrosion can reduce a member's strength, measure this loss if possible and record it on the inspection report.
- Looking for leaching, and noting if it is stained with rust since this condition suggests reinforcing steel corrosion. These defects can grow into larger problems such as delaminations and spalls.



- Investigating the bearing areas for spalled concrete due to friction from thermal movement or crushed concrete due to bearing pressure overloads.
- Checking the member under drains or leaking expansion joints for cracks, delaminations, spalls, and exposed reinforcing steel.
- Checking previously repaired areas for soundness by hammer tapping.
- Looking for collision damage, typically found above or adjacent to traffic lanes or navigation channels.

Element Defects

Refer to Appendix A for Defect descriptions. The defects listed are unique to the element and element material (i.e. concrete, steel, timber, etc.).

- Delamination/Spalls/Patched Areas (1080)
- Exposed Rebar (1090)
- Cracking (RC and Other) (1130)
- Abrasion/Wear (1190)
- Precast Concrete Connections (8906)

Condition State Commentary

Elements exhibiting damage should report the damage in the note of the report under the defect associated with the damage. For instance, the underside of a slab is struck by vehicular traffic and exhibits section loss due to the loss of material. The defect would be reported under the appropriate defect for section loss with the note indicating the section loss was caused by traffic impact.

The inspector is responsible to carry all necessary equipment to make accurate measurements if necessary. Concrete Condition States are dependent on crack width and spall dimensions and depth.

The defects and condition state definitions are based on the AASHTO Manual for Bridge Element Inspection.

Appendix A defines the Condition States for each individual defect. The defects are expounded on and critical areas are discussed to aid the inspector in determining the severity of a defect. The WisDOT Field Manual tabulates the element defects listed above and bases the Condition States on the progression of severity for each defect. The Condition States are comprised of general descriptions and uniquely colored to follow the severity the description represents.

- Condition State 1 Good Green
- Condition State 2 Fair Yellow

- Condition State 3 Poor Orange
- Condition State 4 Severe Red



Figure 2.4.2.2-2: Reinforced Concrete Tee Beams – Condition State 1.



Figure 2.4.2.2-3: Reinforced Concrete Tee Beam – Condition State 2.



Figure 2.4.2.2-4: Corner of Reinforced Concrete Box Girder – Condition State 3.



Figure 2.4.2.2-5: Reinforced Concrete Tee Beam – Condition State 4.



Figure 2.4.2.2-6: Reinforced Concrete Box Girder Bottom Flange Through Thickness Section Loss - Condition State 4.



Figure 2.4.2.2-7: Reinforced Concrete Box Girder Bottom Flange Through Thickness Section Loss - Condition State 4.

2.4.2.3 Reinforced Concrete Arch (Element 144)

Arches are primary elements that receive both compressive and bending moments. By far the most common arch cross-sectional shape is rectangular. Since an arch carries a high degree of compressive load, there should be little if any net tension on any of the surfaces due to bending moments. The main reinforcing steel is distributed uniformly around the perimeter.

Open spandrel arches will have two or more individual arch ribs loaded by vertical spandrel columns. Closed spandrel arches have a single, solid barrel forming the primary load-carrying member. If the closed spandrel is filled with backfill material to support the roadway, then the spandrel walls are also considered to be primary members. This is because they are functioning as bending members to retain the outward pressure caused by the fill. Failure of a spandrel wall would cause the fill to spill out, resulting in roadway settlement. For Element Level Inspection purposes, structural spandrel bent caps, columns, and walls shall be considered part of the arch element. Another important point to note is that filled, closed spandrel arches will always have Assessment 9325 – Roadway over Structure. This assessment is discussed in Part 2 – Chapter 6.



Figure 2.4.2.3-1: Reinforced Concrete Arch Bridge.

Element Level Inspection

This element is for only mild steel reinforced concrete (typical) arches regardless of protective system.

On the inspection report form, reinforced concrete arches are recorded in units of lineal feet. The correct method for calculating the arch length is the sum of all of the lengths of each arch panel measured longitudinally along the travel way. For filled arches, the arch quantity shall be measured from spring line to spring line. The components below the spring line are considered substructures. Where multiple condition states exist within a unit of measure only the predominant defect in severity and extent is recorded. The other defects located within the unit of measure shall be captured by the inspector under the element or appropriate defect notes. The sum of all of the reported condition states must equal the total quantity of



the element. This will quantify the element's condition and help generate quantity/cost estimates for future remedial work.

For filled spandrel reinforced concrete arches where the fascia extends above the roadway over structure, the area below the ground line to the arch shall be evaluated as the arch element. The area above the ground line shall be evaluated using the appropriate bridge railing element.

Element Level Inspection of reinforced concrete arches should include the following items:

- Examining the bearing areas for signs of concrete crushing, since the highest compressive forces experienced by an arch are found at the spring line. Crushing results in a loss of arch cross-sectional area, increasing the axial stresses.
- Looking for longitudinal cracking along the arch axis. Longitudinal cracks indicate a structural overload.
- Checking the entire arch and spandrel wall for delaminations, spalls, and exposed reinforcing steel. These defects reduce these members' cross-sectional area, resulting in higher stresses.
- Checking the entire arch for transverse cracks. These are the result of excessive bending moments or arch support settlements.
- Looking for leaching and rust stains along the entire arch and spandrel wall. These defects can grow into larger problems such as delaminations and spalls.
- Checking areas exposed to drainage and roadway runoff. The runoff may cause scaling, spalling, and concrete contamination.
- Checking to make sure weep holes in closed spandrel arch structures are functioning.
- Checking to make sure surface drains in closed spandrel arch structures are functioning properly, and not allowing water to penetrate the fill.
- Examining previous repair areas for soundness by hammer tapping.

Spandrel Components

All other components that transfer loading to the arch ribs, except the floor system (girders, floor beams and stringers) shall be evaluated under Reinforced Concrete Arch (Element 144). These components include spandrel bent caps, spandrel columns, spandrel walls, etc.

Spandrel bent caps support the decking floor system and transfer the loads to vertical spandrel columns or walls. These components are primary load-carrying members that load the arch ribs. They may also be used on vaulted closed spandrel arches.

Spandrel bent caps are primary load-carrying bending members. They may be bending members on spandrel walls, if their ends cantilever over the ends of the wall, but they are most often used as architectural features in this situation. They often must carry large girder



reaction loads and many times work in conjunction with the spandrel columns to form a frame for resisting lateral loads.

Element Level Inspection of spandrel caps should include the following items:

- Examination for vertical flexural cracks, either on the underside between columns or top side above columns or shafts. Cracks wider than hairline in a flexural region may indicate a serious structural overload.
- Checking for deteriorated concrete in the flexural zones that is causing debonding of the reinforcing steel. This is especially critical near the ends of the reinforcing steel bars, since a certain length of the bar must be embedded within sound concrete to fully develop its strength. The deterioration may be delaminations, spalls, and longitudinal cracks.
- Looking for shear cracks over and near the supports. Shear cracks will be diagonal, extending up from the column towards mid-span. Wide shear cracks suggest the loss of aggregate interlock, meaning the member could be hanging from the reinforcing stirrups. Maximum crack widths should be measured and noted on the bridge inspection report.
- Checking the entire member for signs of corroding reinforcing steel, as indicated by rust stains or exposed reinforcement. Since section loss associated with reinforcing steel corrosion can reduce a member's strength, measure this loss if possible and record it on the inspection report.
- Looking for leaching and noting if it is stained with rust, since this condition suggests reinforcing steel corrosion. These defects can grow into larger problems such as delaminations and spalls.
- Checking the member under drains or leaking expansion joints for cracks, delaminations, spalls, and exposed reinforcing steel.
- Checking previously repaired areas for soundness by hammer tapping.
- Examining the top surface (bearing seat) of caps for cracking and spalling. The pedestals and grout pads under the bearings should also be checked for cracking, spalls, and deterioration that reduce the bearing area. Deterioration in these areas may be caused by the lack of reinforcing steel in older bridges, frozen expansion bearings that transmit lateral forces to the cap not intended for in the original design, and salt-laden water leaking through expansion joints.
- Looking for the presence of debris or standing water on the bearing seat. Debris suggests a failed/leaky expansion joint. Standing water indicates that the bearing seat is dished. Salt-laden standing water will eventually migrate to the reinforcing steel, causing corrosion, delaminations and spalls.

Spandrel columns are primarily compression members, but they must also resist lateral bending moments due to wind loads, eccentric loading at their tops, overloads, and



differential arch deflections. Note that these components are evaluated under the arch element regardless if they are comprised of prestressed concrete or not.

Element Level Inspection of reinforced concrete spandrel columns found on arches should include the following items:

- Checking the arch/spandrel column interface for transverse flexural cracks. These cracks may extend up several feet above the arch rib. They are an indication of excessive column bending due to overloads or differential arch deflection.
- Checking the spandrel bent cap/spandrel column interface for horizontal or diagonal flexural cracks. These cracks will originate at the inside corner of the cap/column junction and are another sign of excessive bent bending due to overloads or differential arch deflection.
- Checking the mid-height of the column for flexural cracks, as this is another sign of structural overloads or differential arch deflection.
- Examining the entire column for longitudinal cracks and crushed concrete. This would be the result of a serious structural overload.
- Checking the entire column for delaminations, spalls, and exposed reinforcing steel. These defects reduce these members' cross-sectional area, resulting in higher stresses. Record this information on the inspection report.
- Looking for leaching, and noting if it is stained with rust since this condition suggests reinforcing steel corrosion. These defects can grow into larger problems such as delaminations and spalls.
- Checking previously repaired areas for soundness by hammer tapping.

On the inspection report form, the arch components other than the ribs shall be evaluated under the arch element as the component's projected length along the arch length. For example, a spandrel column 40 feet tall and 1 foot wide (along the length of the bridge) exhibits 2 inch deep spalling throughout its height. A quantity of 1 foot would be placed in Condition State 3 of Defect 1080 – Delamination/Spalls/Patched Areas under the arch element. It is the inspector's task to examine each component and reasonably assign the appropriate Condition State to the arch element. This will quantify the component's state of deterioration and help generate quantity/cost estimates for future remedial work.



Figure 2.4.2.3-2: Open Spandrel Reinforced Concrete Arch – Cracking Condition State 2.

Element Defects

Refer to Appendix A for Defect descriptions. The defects listed are unique to the element and element material (i.e. concrete, steel, timber, etc.).

- Delamination/ Spall/ Patched Area (1080)
- Exposed Rebar (1090)
- Cracking (RC and Other) (1130)
- Abrasion/Wear (1190)
- Precast Concrete Connections (8906)

Condition State Commentary

Elements exhibiting damage should report the damage in the note of the report under the defect associated with the damage. For instance, the underside of a slab is struck by vehicular traffic and exhibits section loss due to the loss of material. The defect would be reported under the appropriate defect for section loss with the note indicating the section loss was caused by traffic impact.

The inspector is responsible to carry all necessary equipment to make accurate measurements if necessary. Concrete Condition States are dependent on crack width and spall dimensions and depth.

The defects and condition state definitions are based on the AASHTO Manual for Bridge Element Inspection.

Appendix A defines the Condition States for each individual defect. The defects are expounded on and critical areas are discussed to aid the inspector in determining the



severity of a defect. The WisDOT Field Manual tabulates the element defects listed above and bases the Condition States on the progression of severity for each defect. The Condition States are comprised of general descriptions and uniquely colored to follow the severity the description represents.

- Condition State 1 Good Green
- Condition State 2 Fair Yellow
- Condition State 3 Poor Orange
- Condition State 4 Severe Red



2.4.3 Prestressed Concrete Structures

Prestressed concrete superstructures have been gaining popularity since the 1950s, with the subsequent development of post-tensioned concrete boxes, allowing concrete to gain acceptance for use on medium and long span bridges. Prestressed concrete superstructures can be configured in many different ways, including:

1. **Precast prestressed voided slab:** Precast voided slabs are bridges similar to cast-in-place slabs in that each slab acts as a single, wide beam spanning from substructure unit to substructure unit. As with cast-in-place slabs, the precast slab also acts as the deck. Precast voided slabs, however, are manufactured in a plant and pretensioned. These precast slabs contain circular or elliptical voids for reducing material and weight. Each slab or plank is usually 3 or 4 feet wide, with depths ranging from about 15 to 26 inches. Each slab is placed tight side by side and transversely clamped together so that the individual planks act as a unit under live loads. Grouted shear keys also help the beams to act together. Precast voided slabs are used for simple spans of about 70 feet. The main steel prestressing strands are placed parallel to traffic, and located towards the bottom of the slab. Precast voided slabs will generally have two or three voids. While contrary in name, these superstructure elements would be evaluated as closed web/box girders along with a top flange element.
2. **Prestressed box beams:** Precast box beams are bridges similar to precast voided slabs. However, precast box beams contain only a single void. In early applications, the top flange of the box beam also acted as the deck. Current practice is to place an asphalt overlay or separate concrete overlay or deck on top of the beams. Concrete decks often act compositely with the box beams. Each beam is usually 3 or 4 feet wide, having a depth ranging from about 12 to 60 inches. Each beam may be placed side by side and transversely clamped together so that the individual beams act as a unit under live loads. Grouted shear keys also help the beams to act together. They may also be spaced 2 to 6 feet apart to form a bridge similar in appearance to a tee beam bridge. Prestressed box beams are used for simple spans from about 20 to 130 feet in length. The main steel prestressing strands are placed parallel to traffic and located in the bottom flange of the box. Conventional reinforcing steel ties are placed transversely along the beam for shear reinforcement.
3. **Prestressed I-beams and Bulb-Tees:** Prestressed I-beams and bulb-tees are commonly precast members without voids. They make for efficient use of material by concentrating the concrete away from the beam's neutral axis where it is needed most for stiffness and strength. Concrete decks are often designed to act compositely with the I-beams. They are used for simple spans up to about 160 feet in length. They may also be made continuous over piers for live loads and secondary dead loads. This is done by placing conventional reinforcing steel longitudinally in the deck over the piers to resist negative bending. The main steel prestressing strands are placed parallel to traffic and located in the bottom flange of the beam. Conventional reinforcing steel ties are placed transversely along the beam for shear reinforcement. Secondary members of prestressed I-beam bridges include concrete diaphragms at the abutments and piers and either steel or concrete diaphragms within the spans.



Figure 2.4.3-1: Prestressed I-beams.

- 4. Prestressed Double Tees:** Double tee beams are commonly used in building applications such as parking garages but have since been adopted into bridge structures. As the name suggests, the component resembles two T's that are side by side. These superstructures are typically used in shorter simple spans but may be used in continuous applications. Segments are held together through the use of lateral connectors. Also a wearing surface is typically placed over the tops of the beams to create a uniform driving surface and to seal the longitudinal joints between beams. Prestressed double tee superstructures may resemble cast-in-place tee beams however the longitudinal joint seen underneath and the thinner stems of the beams indicate prestressed concrete. Double tee beams are typically constructed with 12-34 inch stems (legs) with flange width (out-out of each segment) ranging from 8 to 10 feet. The bridges typically span 25-55 feet. Primary prestressing stands are placed near the bottom of the legs. Conventional steel reinforcing is placed longitudinally as temperature and shrinkage steel. In continuous applications, ducts may be draped through the stems to allow for post-tensioning. Shear reinforcing U-shaped stirrups are placed vertically in the stems and extend up into the flange. Primary flange reinforcing is placed transversely and follows the placement of a typical concrete deck.



Figure 2.4.3-2: Double Tee Girder Bridge.

5. **Box girders:** Box girder bridges are used for very long structures and curved spans. The sections are very large, and a single box can be used to carry an entire roadway. Insides of the boxes are usually large enough for inspectors to enter. Traditional box girders are cast-in-place and may be conventionally reinforced or post-tensioned. Cast-in-place box girders will often contain several internal vertical webs and are referred to as multi-cell box girders. Concrete box girders are used for spans in excess of 150 feet. The main reinforcement of post-tensioned box girders is a combination of conventional steel reinforcement and post-tensioning tendons. This reinforcement is placed in the bottom flange between the substructure units to resist positive bending and in the top flange above the piers to resist negative bending. The post-tension tendons are normally placed within galvanized steel ducts. Conventional reinforcing steel ties are placed transversely along the beam for shear and torsion reinforcement.



Figure 2.4.3-3: Conventionally Reinforced Box Girder Bridge.

6. **Segmental box girders:** Segmental box girder bridges are similar to traditional box girders. However, the segments of segmental box girders are manufactured at a precast plant, shipped to the site, and erected individually. They commonly have a trapezoidal shape, with the top flange cantilevering over the inclined webs, and normally contain only one cell. All are post-tensioned.



Figure 2.4.3-4: Segmental Box Girder Bridge.

2.4.3.1 Prestressed Concrete Closed Web/Box Girder (Element 104)
Prestressed Concrete Open Girder (Element 109)
Prestressed Concrete Stringer (Element 115)
Prestressed Concrete Floor Beam (Element 154)

These elements include factory-manufactured prestressed open or box beams, field cast/post-tensioned box girders, post-tensioned segmental box girders, and post-tensioned segmental arches.

These are primary bending elements that are typically plant-fabricated precast/prestressed open: I-beams, bulb tees, inverted channels, closed boxes, and segmental post-tensioned closed boxes. On closed box shapes and inverted channel sections, the top flange may also function as the bridge deck. Stringers account for all prestressed members that support the deck in a floor system. Floor beams account for all prestressed floor beams that typically support stringers in a floor system.



Figure 2.4.3.1-1: Prestressed Concrete I-Beam Bridge.

Each of these elements are stressed in axial compression, therefore, the inspector should not expect to find any transverse flexural cracks. Transverse flexural cracks indicate a structural overload to the member, and these cracks should be measured and recorded.

For multi-span bridges, open prestressed girders are usually designed for live load and secondary dead load continuity over the piers. This is accomplished by placing longitudinal conventional reinforcing steel bars over the piers within the deck. A cast-in-place diaphragm is placed over the piers to fill the gap between the girder ends and to laterally lock them into position. As live or secondary dead loads are placed on the deck, negative bending is resisted by compression in the girder's bottom flange and diaphragm and by tension within the deck longitudinal continuity steel.



Element Level Inspection

On the inspection report form, prestressed concrete girders, stringers, and floor beams are recorded in units of lineal feet. The correct method for calculating the girder/beam length is multiplying the number of beams in each span times the span length of each span. For box girders and double tees, all legs or webs monolithic with the top flange are considered 1 girder. That is a 50 foot long double tee beam girder would be measured 50 feet, not be quantified as 100 feet (50 feet for each leg). Where multiple condition states exist within a unit of measure only the predominant defect in severity and extent is recorded. The other defects located within the unit of measure shall be captured by the inspector under the element or appropriate defect notes. The sum of all of the reported condition states must equal the total quantity of the element. This will quantify the element's condition and help generate quantity/cost estimates for future remedial work.

For box girders or other beams where traffic drives directly on the top flange, regardless of wearing surface, the top flange, above the fillet, shall be assessed as Element 15 – Prestressed Concrete Top Flange. The remaining portion of the beam shall be evaluated under the appropriate superstructure element. Refer to Chapter 3 of Part 2 for more information on deck and top flange elements and their associated material defects.

Element Level Inspection of prestressed closed web/box, open girders and stringers should include the following items:

- Looking for transverse flexural cracks on the girder underside in the positive moment regions. Their presence indicates a serious structural overload or loss of prestressing/post-tensioning force. The inspector should measure the crack widths and lengths and document their location.
- Examining the beam ends for evidence of cracked or spalled concrete, sometimes accompanied with corroded reinforcing strands. This may occur due to leaking expansion joints that corrodes the reinforcing or prestressing steel. It may also be the result of a lack of non-prestressed reinforcement in the zone of prestressing force transfer.
- Sighting down the length of the beams to check for sagging. Sagging is a sign that the beam is losing its prestressing force and is unable to carry the loads for which it was designed.
- Looking for diagonal shear cracks on the girder sides near the abutments and piers.
- Looking for vertical cracks on the girder sides near the abutments and piers. Vertical cracks in these areas suggest the bearing assemblies are restricting girder movement.
- Examining the beam underside for parallel longitudinal cracks. These usually occur along the prestressing strands and may occur due to inadequate concrete cover. Rust stains that accompany the cracks suggest that the prestressing strands are corroding and debonding.



- Checking for leakage/efflorescence between the longitudinal joint of prestressed box beams placed next to each other. This condition, along with reflective longitudinal cracking on the deck surface, suggests that the grouted shear keys between the members have failed. Once these shear keys have failed, live loads cannot be shared between adjacent beams.
- Checking for excessive or differential deflections between box or channel beams placed next to each other. This is a sign that the beam is losing its prestressing force and is unable to carry the loads for which it was designed. It also indicates failed grouted shear keys.
- Verifying that the drain holes are open on prestressed box beams.
- Looking for delaminations, spalls, and exposed reinforcing steel.
- Checking for any superelevation irregularities on curved box girder bridges. This is a sign that torsional distress has occurred.
- Documenting box girder top flange transverse flexural cracks and any leaching and rust staining that may accompany them. This will usually be performed during an in-depth inspection, as the underside of a box girder's top flange can only be seen from inside the cells.
- Signs of impact damage include scrapes on member undersides, chips, cracks, spalls, and possibly a broken out section of a member. Particularly strong collisions will expose several reinforcing bars or prestressing strands. Underside scrapes are an indication of vehicle contact with the superstructure, and are typically found above or adjacent to traffic lanes or navigation channels.

Element Defects

Refer to Appendix A for Defect descriptions. The defects listed are unique to the element and element material (i.e. concrete, steel, timber, etc.).

- Delamination/ Spall/ Patched Area (1080)
- Exposed Prestressing (1100)
- Cracking (PSC) (1110)
- Abrasion/Wear (1190)
- Precast Concrete Connections (8906)

Condition State Commentary

Elements exhibiting damage should report the damage in the note of the report under the defect associated with the damage. For instance, the underside of a slab is struck by vehicular traffic and exhibits section loss due to the loss of material. The defect would be

reported under the appropriate defect for section loss with the note indicating the section loss was caused by traffic impact.

The inspector is responsible to carry all necessary equipment to make accurate measurements if necessary. Concrete Condition States are dependent on crack width and spall dimensions and depth.

The defects and condition state definitions are based on the AASHTO Manual for Bridge Element Inspection.

Appendix A defines the Condition States for each individual defect. The defects are expounded on and critical areas are discussed to aid the inspector in determining the severity of a defect. The WisDOT Field Manual tabulates the element defects listed above and bases the Condition States on the progression of severity for each defect. The Condition States are comprised of general descriptions and uniquely colored to follow the severity the description represents.

- Condition State 1 Good Green
- Condition State 2 Fair Yellow
- Condition State 3 Poor Orange
- Condition State 4 Severe Red



Figure 2.4.3.1-2: Prestressed I-Beam – Condition State 1.



Figure 2.4.3.1-3: Prestressed I-Beams – Condition State 1.



Figure 2.4.3.1-4: Prestressed Channel Beams – Cracking Condition State 3.



Figure 2.4.3.1-5: End of Prestressed I-Beam with Spalls and Exposed Strands and Rebar – Delamination/Spall/Patched Area Condition State 3.



Figure 2.4.3.1-6: Prestressed Channel Beams with Exposed Strands, Longitudinal Cracks, Leaching, and Rust Staining – Cracking Condition State 4.



Figure 2.4.3.1-7: Delaminated/Spalled Prestressed Beam End with Exposed Strands – Exposed Prestressing Condition State 4.

2.4.3.2 Prestressed Concrete Arch (Element 143)

Prestressed arches are rare forms of the concrete arch. Arches are primary load-carrying elements that carry axial compressive stresses, as well as bending, tension, and compressive stresses. Normally, the axial loads are great enough on an arch that there are no net tensile stresses due to bending. When bending stresses are large enough to produce net tension, post-tensioning is used to pre-compress the arch cross-section. This keeps the entire cross-section in compression, eliminating any net tensile stress.



Figure 2.4.3.2-1: Open Spandrel Prestressed Arch Bridge with Struts.

Since prestressed arches are stressed in axial compression, the inspector should not expect to find any transverse flexural cracks. Transverse flexural cracks indicate a structural overload to the member, and these cracks should be measured and recorded.

Element Level Inspection

This element is for prestressed or post-tensioned arches regardless of protective system.

On the inspection report form, prestressed concrete arches are recorded in units of lineal feet. The correct method for calculating the arch length is the sum of all of the lengths of each arch panel measured longitudinally along the travel way. For filled arches, the arch quantity shall be measured from spring line to spring line. The components below the spring line are considered substructures. Where multiple condition states exist within a unit of measure only the predominant defect in severity and extent is recorded. The other defects located within the unit of measure shall be captured by the inspector under the element or appropriate defect notes. The sum of all of the reported condition states must equal the total quantity of the element. This will quantify the element's condition and help generate quantity/cost estimates for future remedial work.



For filled spandrel reinforced concrete arches where the fascia extends above the roadway over structure, the area below the ground line to the arch shall be evaluated as the arch element. The area above the ground line shall be evaluated using the appropriate bridge railing element.

Element Level Inspection of prestressed arches should include the following items:

- Looking for transverse flexure cracks along the arch. Their presence indicates a serious structural overload, loss of prestressing/post-tensioning force or arch support settlements. The inspector should measure the crack widths and lengths, and document their location.
- Examining the bearing areas for signs of concrete crushing, since the highest compressive forces experienced by an arch are found at the spring line. Crushing results in a loss of arch cross-sectional area, increasing the axial stresses.
- Looking for longitudinal cracking along the arch axis. Longitudinal cracks indicate a structural overload.
- Checking the entire arch for delaminations, spalls, and exposed reinforcing steel. These defects reduce the members' cross-sectional area, resulting in higher stresses.
- Looking for leaching and rust stains along the entire arch. These defects can grow into larger problems such as delaminations and spalls.
- Checking areas exposed to drainage and roadway runoff. The runoff may cause scaling, spalling, and concrete contamination.
- Examining previous repair areas for soundness by tapping with a hammer.

Spandrel Components

All other components that transfer loading to the arch ribs, except the floor system (girders, floor beams and stringers) shall be incorporated in the Prestressed Concrete Arch (Element 143) Condition States. These include spandrel bent caps, spandrel columns, spandrel walls, etc.

Spandrel bent caps support the decking floor system and transfer the loads to vertical spandrel columns or walls. These components are primary load-carrying members that load the arch ribs. They may also be used on vaulted closed spandrel arches.

Spandrel bent caps are primary load-carrying bending members. They may be bending members on spandrel walls if their ends cantilever over the ends of the wall, but they are most often used as architectural features in this situation. They often must carry large girder reaction loads and many times work in conjunction with the spandrel columns to form a frame for resisting lateral loads.

Element Level Inspection of spandrel caps should include the following items:



- Examination for vertical flexural cracks, either on the underside between columns or top side above columns or shafts. Cracks wider than hairline in a flexural region indicate a serious structural overload.
- Checking for deteriorated concrete in the flexural zones that is causing debonding of the reinforcing steel. This is especially critical near the ends of the reinforcing steel bars, since a certain length of the bar must be embedded within sound concrete to fully develop its strength. The deterioration may be delaminations, spalls, and longitudinal cracks.
- Looking for shear cracks over and near the supports. Shear cracks will be diagonal, extending up from the column towards mid-span. Wide shear cracks suggest the loss of aggregate interlock, meaning the member could be hanging from the reinforcing stirrups. Maximum crack widths should be measured and noted on the bridge inspection report.
- Checking the entire member for signs of corroding reinforcing steel, as indicated by rust stains or exposed reinforcement. Since section loss associated with reinforcing steel corrosion can reduce a member's strength, measure this loss if possible and record it on the inspection report.
- Looking for leaching and noting if it is stained with rust, since this condition suggests reinforcing steel corrosion. These defects can grow into larger problems such as delaminations and spalls.
- Checking the member under drains or leaking expansion joints for cracks, delaminations, spalls, and exposed reinforcing steel.
- Checking previously repaired areas for soundness by hammer tapping.
- Examining the top surface (bearing seat) of pier caps for cracking and spalling. The pedestals and grout pads under the bearings should also be checked for cracking, spalls, and deterioration that reduce the bearing area. Deterioration in these areas may be caused by the lack of reinforcing steel in older bridges, frozen expansion bearings that transmit lateral forces to the pier not intended for in the original design, and salt-laden water leaking through expansion joints.
- Looking for the presence of debris or standing water on the bearing seat. Debris suggests a failed/leaky expansion joint. Standing water indicates that the bearing seat is dished. Salt-laden standing water will eventually migrate to the reinforcing steel, causing corrosion, delaminations, and spalls.

Spandrel columns are primarily compression members, but they must also resist lateral bending moments due to wind loads, eccentric loading at their tops, overloads, and differential arch deflections. Note that these components are evaluated under the arch element regardless if they are comprised of prestressed concrete or not.

Element Level Inspection of reinforced concrete spandrel columns found on arches should include the following items:



- Checking the arch/spandrel column interface for transverse flexural cracks. These cracks may extend up several feet above the arch rib. They are an indication of excessive column bending due to overloads or differential arch deflection.
- Checking the spandrel bent cap/spandrel column interface for horizontal or diagonal flexural cracks. These cracks will originate at the inside corner of the cap/column junction and are another sign of excessive bent bending due to overloads or differential arch deflection.
- Checking the mid-height of the column for flexural cracks, as this is another sign of structural overloads or differential arch deflection.
- Examining the entire column for longitudinal cracks and crushed concrete. This would be the result of a serious structural overload.
- Checking the entire column for delaminations, spalls, and exposed reinforcing steel. These defects reduce these members' cross-sectional area, resulting in higher stresses.
- Looking for leaching, and noting if it is stained with rust since this condition suggests reinforcing steel corrosion. These defects can grow into larger problems such as delaminations and spalls.
- Checking previously repaired areas for soundness by hammer tapping.

On the inspection report form, the arch components other than the ribs shall be assessed under the arch element as the component's projected length along the arch length. It is the inspector's task to examine each component and reasonably assign the appropriate Condition State to the arch element. This will quantify the component's state of deterioration and help generate quantity/cost estimates for future remedial work.

Element Defects

Refer to Appendix A for Defect descriptions. The defects listed are unique to the element and element material (i.e. concrete, steel, timber, etc.).

- Delamination/ Spall/ Patched Area (1080)
- Exposed Prestressing (1100)
- Cracking (PSC) (1110)
- Abrasion/Wear (1190)
- Precast Concrete Connections (8906)

Condition State Commentary

Elements exhibiting damage should report the damage in the note of the report under the defect associated with the damage. For instance, the underside of a slab is struck by



vehicular traffic and exhibits section loss due to the loss of material. The defect would be reported under the appropriate defect for section loss with the note indicating the section loss was caused by traffic impact.

The inspector is responsible to carry all necessary equipment to make accurate measurements if necessary. Concrete Condition States are dependent on crack width and spall dimensions and depth.

The defects and condition state definitions are based on the AASHTO Manual for Bridge Element Inspection.

Appendix A defines the Condition States for each individual defect. The defects are expounded on and critical areas are discussed to aid the inspector in determining the severity of a defect. The WisDOT Field Manual tabulates the element defects listed above and bases the Condition States on the progression of severity for each defect. The Condition States are comprised of general descriptions and uniquely colored to follow the severity the description represents.

- Condition State 1 Good Green
- Condition State 2 Fair Yellow
- Condition State 3 Poor Orange
- Condition State 4 Severe Red

2.4.4 Steel Structures

Since the late 1800s, steel has been one of the most commonly used materials to construct bridge superstructures. The steel can be configured in many different ways, and it is used to create virtually any bridge type, including:

1. **Rolled multi-beams:** Rolled multi-beams are bridges constructed using three or more hot-rolled steel beams as the primary members. Beam depths are usually no more than 36 inches, which limits spans to about 90 feet maximum. Transverse diaphragm secondary members, usually C-shaped channel sections, may be bolted or riveted to the beam webs. To increase a beam's bending capacity; cover plates may be riveted, bolted or welded to the underside of the bottom flange. Unfortunately, the ends of welded cover plates create a significant stress riser and a highly fatigue prone detail.



Figure 2.4.4-1: Rolled Steel Multi-beam Bridge.

2. **Fabricated multi-girders:** Fabricated multi-girders are bridges constructed using three or more built-up steel girders as the primary members. The girders are fabricated by either riveting/bolting together steel plates and angles or by welding steel plates together. Greater economy is typically achieved by varying flange thickness/width or the number of plates in a flange to accommodate the bending moment magnitude. Web depths may also be deepened (haunched) over the piers to achieve the same effect. Girder depths are usually greater than 36 inches, allowing for spans up to about 500 feet. Due to their greater web depths, transverse cross-frames using angles or T-shapes are usually used as secondary elements. In addition, vertical and/or longitudinal stiffeners may be welded or riveted to the web to prevent web buckling. Older structures may use lateral bracing placed at the same level of the bottom or top girder flanges to connect adjacent girders. Larger spans may be built with a floor system consisting of stringers and floor beams as additional primary members. Floor beams are transverse beams that frame into the girder webs. The stringers bear on or frame into floor beams. Stringers are usually rolled beams placed between and running parallel to the girders. Along with the girders, the stringers directly support the deck. Stringers and floor beams are not nonredundant steel tension members (NSTMs).



Figure 2.4.4-2: Steel Multi-Girder Bridge.

3. **Two-girder systems:** Two-girder systems are bridges constructed using only two built-up steel girders as primary members. These bridges have floor systems that use floor beams and sometimes stringers. Features of two-girder systems are also common to fabricated multi-girder systems. Two-girder systems do not have load path redundancy and therefore are classified as NSTM bridges. Floor beams in this configuration may be considered NSTM, depending on the spacing between them.



Figure 2.4.4-3: Two Girder System Bridge.

4. **Through girders:** Through girder bridges are similar to two-girder bridges but the deck is placed between the girders rather than on top of them. Many older short- to medium-span highway and railroad bridges use this configuration. These types of bridges are two-girder systems and are therefore classified as NSTM bridges.



Figure 2.4.4-4: Steel Through Girder Bridge.

5. **Box girders:** Box girder bridges have girders fabricated from plates welded into a rectangular or trapezoidal closed shape. Because closed shapes are stiffer in torsion than open “I” shaped girders, box girders are commonly used for curved spans. Closed shapes also help to better protect the steel from corrosion since only half the plate area is exposed to the elements. The vertical plates form the webs, the bottom plate forms the bottom flange, and the top plate (if present) or concrete deck forms the top flange. Both the web and flange plates are normally strengthened with transverse and longitudinal stiffeners to prevent buckling. Box girders can usually be entered through access hatches for inspection of their interiors. Bridges using one box girder do not have load path redundancy and are therefore classified as NSTM bridges. Most two box girder bridges are also classified as NSTM. However, some two girder bridges have been designed with substantial bracing between the boxes so that one of them can support the entire bridge should the other fail. Box girder bridges used in simple span applications can span up to 75 feet. When used in continuous applications, spans of over 100 feet can be attained.



Figure 2.4.4-5: Steel Box Girder Bridge.

- Trusses:** Truss bridges are structures with two or more parallel trusses being the main load-carrying members. The deck may be placed on top of the trusses (deck truss) or between the trusses (through truss when there is overhead lateral bracing or a pony truss when there is no overhead lateral bracing). Through or pony trusses are most often constructed using two trusses, and therefore are considered NSTM structures. Deck trusses are constructed with two or more trusses. Only two truss deck trusses are NSTM structures. Truss chord, diagonal, and vertical members may be fabricated from eyebars, rolled shapes, or built-up members. Connections are made with rivets, bolts, welds, and pin connections. All truss bridges have floor systems similar to two-girder systems. To keep the two trusses in line longitudinally, secondary lateral bracing members diagonally connect the bottom chords. For deck and through trusses, the top chords are connected the same way. Sway bracing keeps the two trusses in line laterally. On deck and through trusses, sway bracing transversely frames between the truss verticals. On through trusses, sway bracing may limit vertical clearances. On pony trusses, sway bracing is usually placed as a transverse diagonal on the outside of the trusses. It connects the top chord to transverse “outrigger” floor beam extensions and functions to prevent buckling of the top chord.

**Figure 2.4.4-6:** Steel Truss Bridge.

- Deck arches:** Deck arch bridges are structures with the deck placed on top of two or more riveted, bolted, or welded arches. The arches are the main load-carrying members, and their ends bear on foundations at grade. Their bearing ends are usually pinned and the end reactions have a vertical component due to the dead and live gravity loads, and a horizontal component due to the arch's outward thrust. A pin may also be present at the arch crown, forming a three-hinged arch. The area between the deck and arch is known as the spandrel. Deck arches use vertical compression members, called spandrel columns, to deliver the deck loads to the arch

ribs. The spandrel columns may be rolled or built-up shapes. Each arch rib may be fabricated into an “I” or box shape (solid rib arch) or into a truss shape (braced rib arch). When diagonal braces connect the spandrel columns above the rib, the bridge is classified as a spandrel braced arch. The floor system will contain floor beams, spandrel girders, and sometimes stringers. Secondary members include the upper and lower lateral bracing which brace the floor system and arch ribs, respectively. Transverse sway bracing keeps the ribs and spandrels in line laterally. Although many deck arch bridges have only two arch ribs, the bridges are not considered NSTM since arches resist a combination of compression loads and bending moments, not tension.



Figure 2.4.4-7: Steel Deck Arch Bridge.

8. **Through arches:** Through arch bridges are structures with the deck placed below the crown of and between two riveted, bolted, or welded arches. As with deck arches, the arches are the main load-carrying members and are usually pinned, with the ends bearing on foundations at grade. A pin may also be present at the arch crown to form a three-hinged arch. Through arches use vertical tension members to suspend the deck under the arch ribs. The tension members may be steel cables, wire rope, or solid steel hangers. Each arch rib may be fabricated into a box shape (solid rib arch) or more commonly into a truss shape (braced rib arch). The floor system will contain floor beams, girders, and sometimes stringers. Secondary members include lateral bracing for the arch ribs and floor system, and transverse sway bracing to keep the ribs in line laterally. As with deck arches, most through arches are not NSTM bridges. The exception is the tied arch.
9. **Tied arches:** Tied arch bridges are special types of through arches. The ends of tied arches bear on piers, and are tied together with a tie girder. The tie girder is in tension and necessary to resist the very large horizontal thrusts of the arch rib. It functions in a similar manner to the string on an archer’s bow. Because tied arch bridges have only two arches and two tie girders, tied arch bridges are considered NSTM since there are only two tie girders and they are in tension. A failure of one tie

girder will directly lead to a failure of its associated arch. The tie girder may also behave as a bending member, in conjunction with the ribs, to deliver dead and live gravity loads to the pier. Primary and secondary members of tied arches are similar to those of through arches, although the arch ribs are typically solid box shaped elements. Floor beams frame directly into the webs of the tie girders, and cables or hangers (solid or hollow) directly support the tie girder. The hangers may be oriented vertically or diagonally.



Figure 2.4.4-8: Steel Tied Arch Bridge.

- 10. Rigid frames:** Rigid frame bridges are structures in which the structure's inclined supporting "legs" are integrated with the girders to form a rigid frame. Rigid frames are usually constructed using welded plate girders and legs to form a "K" shape or, in some instances, an inverted triangular delta shape. Though the legs are used as bridge piers, the legs are actually part of the superstructure because of their rigid connection to the girders. This rigid intersection of the leg and girder is referred to as the knee and allows both the girders and legs to resist bending moments. Large moments and shear forces are resisted by the knee, resulting in a complex arrangement of stiffeners in this area. The legs are pinned at grade, and the girder ends supported by conventional abutments. Rigid frame bridges may use two or more frames to support the deck. The girders, legs, and bearings are all primary members on multi-rigid frame. Secondary members are the diaphragms, cross-frames, longitudinal stiffeners, transverse stiffeners, and radial stiffeners. Spans 50 to 200 feet are attainable using rigid frames.



Figure 2.4.4-9: Steel Rigid Frame Bridge.

11. **Cable-stayed bridges:** Cable-stayed bridges are typically long span structures that use one or two planes of inclined stay cables as their main means of support. The stay's opposite ends are attached to pylons, which deliver the cable forces to the foundation. Spans from 700 -1400 feet are attainable using cable-stayed bridges.



Figure 2.4.4-10: Cable Stayed Pedestrian Bridge.

12. **Suspension bridges:** Suspension bridges are typically long span structures that support the deck from vertical suspender cables attached to two or more catenary main suspension cables. The main suspension cables are draped over towers, and their ends fixed to gravity anchors.



Figure 2.4.4-11: Steel Pedestrian Suspension Bridge.

Steel superstructures are classified as being either NSTM or non-NSTM. Refer to Section 1.4.2.4 for a discussion of NSTM bridges and inspection procedures.

2.4.4.1 Steel Closed Web/Box Girder (Element 102)

Steel Open Girder/Beam (Element 107)

Steel Stringer (Element 113)

Steel Floor Beam (Element 152)

Steel Cross Girder – Closed Web/Box Girder (8102)

Steel Cross Girder – Open Girder/Beam (8107)

These steel elements are either hot-rolled structural sections (wide flanged section, channels, angles, plates) or are built-up by riveting, bolting or welding together two or more hot-rolled structural sections.

These elements are primary load-carrying bending members. Hot-rolled beams of multi-beam bridges may be recorded as either an open girder or stringer, depending upon the inspector's interpretation of these terms. In the case where a deck is supported by a floor system, stringers shall be recorded as those beams that tie into the floor beam and girders shall be recorded as those beams that floor beams tie into.

Steel Cross Girders are oriented perpendicular to the direction of the main girders ensuring the main girders act together and share loads. The element must be located above the bearings to be a cross girder. If the element is located below the bearings, it is considered a pier cap. A cross girder is not a diaphragm or a floor beam.



Figure 2.4.4.1-1: Steel Cross Girder – Closed Web/Box Girder

Element Level Inspection

These elements refer to those beam elements regardless of protective system. The Condition States of these elements are independent of the protective coating on the element. Refer to Part 2 Chapter 6 Steel Protective Coatings for inspection methods and defects of paint and other protective coatings.

On the inspection report form, steel girders/beams are recorded in units of lineal feet. The correct method for calculating the beam length is the sum of all of the lengths of each beam section and multiplying by the span length for each span. For steel box girders, one box is considered one beam section. Where multiple condition states exist within a unit of measure only the predominant defect in severity and extent is recorded. The other defects located within the unit of measure shall be captured by the inspector under the element or appropriate defect notes. The sum of all of the reported condition states must equal the total quantity of the element. This will quantify the element's condition and help generate quantity/cost estimates for future remedial work.

The evaluation of steel beams is three-dimensional in nature. The inspector shall evaluate all faces and determine the predominant defect for each unit of measure along the element. This includes evaluating all faces, interior and exterior, of box girders per linear foot and recording the controlling defect. If multiple defects are found within the same unit of measure, the inspector shall record the predominant defect on the inspection report and describe other defects within the notes under the element. The predominant defect is determined first by



Condition State. If Condition States are equal, the hierarchy then falls to the lowest associated defect number.

Maintenance inspection of box girders, open girders, stringers, and floor beams should include examination of the rust texture and color of the steel surface to judge if the corrosion is active or if there is the desired oxide coating. Problems are most likely to be found under leaky expansion joints, areas subjected to constant traffic spray, and areas that accumulate debris or bird waste. The inspector should look for signs of active corrosion on the steel surfaces. These signs, in order of decreasing severity, include:

1. Deep pitting of the surface;
2. Laminar rust or visible laminations on steel edges;
3. Surfaces that can be rubbed off by hand or with a wire brush;
4. Flakes 1/2 inch in diameter;
5. Flakes 1/8 inch in diameter;
6. Surfaces with a granular and flaky texture; and
7. Surfaces with a coarse texture.

For all of these situations, the remaining metal thickness should be measured with calipers or an ultrasonic thickness gauge.

Safety Inspection

During the Element Level Inspection of primary bending members, it is extremely important to remember that the entire purpose of a bridge inspection is to ensure public safety. A structural inspection must also be carried out. The main purpose of these primary members is to transmit loads to the substructure, and a structural failure of one could mean a local bridge failure, requiring that part or all of the bridge be shut down. Failure of a NSTM open girder would cause a probable collapse of the entire bridge.

Flexural Areas: Girders, beams, and stringers experience bending throughout their lengths. The largest bending moments occur around midspan on simply supported members. On continuous members, the largest positive bending moments are located around midspan, and the largest negative bending moment locations are directly over the interior supports. Since stringers are supported by floor beams, they will behave in a manner similar to continuous girders. There is no bending experienced by either simply supported or continuous members at expansion joints

Maintenance inspection in the flexural areas of steel box girders, open girders, stringers, and floor beams should include the following items:

- Examining the flexure zones and tension flanges for corrosion and loss of cross-sectional area, which is the most common steel defect. About 10 percent flange section loss or more will begin to raise the stress level an appreciable amount.



- Removing of spot areas of debris accumulation to check for corrosion. Bird waste that is often found on the flanges is acidic and traps moisture and road salts, accelerating corrosion.
- Checking rivet/bolt heads on built-up components, as corrosion on the heads may indicate corrosion along the entire fastener length, reducing structural integrity.
- Looking for pack rust, noted by individual plate bending between fasteners. Pack rust may be present between the plies of riveted/bolted connections such as field splices or secondary member connections.
- Looking for overload damage in the form of compression flange buckling and tension flange elongation or fracture in the high moment flexural regions.
- Looking for torsion related damage on curved box girders at the diaphragms/cross-frames, webs, and flanges as evidenced by plate or member distortions.
- Examining suspect fasteners for looseness by twisting by hand or tapping the heads with a hammer.
- Checking the girders for distortion or scraping caused by traffic impacts. The impact damage is usually most prominent on the fascia girders.
- Viewing down the member's length to check vertical and horizontal alignments, as well as for any canting (lateral bending or twisting). This type of damage may be due to overloads, traffic impact or support settlement.

Shear Zones: The zones of highest shear stresses are at the abutments and both sides of the piers. Most beams and girders have vertical bearing stiffeners at their supports.

Maintenance inspection in the shear areas of steel box girders, open girders, stringers, and floor beams should include the following items:

- Looking for web crippling where bearing stiffeners are not used. Web crippling is a permanent wrinkling or buckling of the web due to overloads.
- Checking for excessive web section loss due to corrosion, especially under expansion joints and integral abutments, where the steel may remain damp for extended periods. Web section loss increases shear stresses and makes the web less stiff and more susceptible to crippling.
- Checking the bearing stiffeners for excessive corrosion and any associated buckling due to overloads.

Safety Inspection - Fatigue

Primary bending members are susceptible to fatigue damage. Fatigue cracks usually show up as rust stains or rusty breaks in the paint, propagating perpendicular to the direction of stress. An excellent resource discussing fatigue related damage in bridges is the *Manual for Inspecting Bridges for Fatigue Damage Conditions*. This resource contains background



information, inspection techniques, and many photographs/diagrams illustrating suspect fatigue prone details and damage.

The following text attempts to summarize locations for fatigue prone details and what the inspector should examine on hot-rolled beams, fabricated girders, box girders, floor system components, and riveted/ bolted members. Nonetheless, it is strongly recommended that the inspector become familiar with the *Manual for Inspecting Bridges for Fatigue Damage Conditions*. Any fatigue related damage found should be recorded under defect 1010 *Cracking*.

Hot-Rolled Beams: Fatigue inspection of hot-rolled steel beams should include the following items:

- Checking for in-plane bending fatigue cracks which are most likely to develop at the ends of cover plates welded to the tension flange. This detail must be inspected carefully, since it has one of the lowest fatigue strengths of any welded detail, and a tension flange failure could have catastrophic effects.
- Looking at the diaphragm connection plates that are welded to the tension flange, as these act as stress risers. Transverse cracks may occur in the flange.
- Checking for out-of-plane bending cracks that may be found at diaphragm connections of skewed bridges. Since the diaphragms may not line up end-to-end, differential beam deflections can cause the diaphragm to push/bend the web out of plane when the connection plate is not connected to the flange. A similar condition exists at the fascia beams of non-skewed bridges. The damage typically shows up as a “U” shaped crack on the web, traveling around the diaphragm connection plate’s clipped corner at the flange. The connection plate is usually fillet welded to the web on both sides, and the crack occurs either within the weld or in the web material at the weld toe. On continuous spans, the connection plate is often not welded to the top tension flange over the piers. In this situation, fatigue cracks may develop in the shape of an upside down “U” at the connection plate’s upper clipped corner. Horizontal cracks may also occur at the toe of the flange/web fillet due to the high lateral restraint of the top flange provided by deck embedment. Though rare, out-of-plane bending may crack welds joining the connection plate to the flange.

Fabricated Girders: In-plane bending at fatigue prone details on fabricated girders is similar to those found on hot-rolled beams. In addition, fatigue inspection in the flexural areas of fabricated steel girders should include the following items:

- Investigating longitudinal stiffener butt welds located within tension or stress reversal zones. These carry the same longitudinal stresses as the girder web and may produce fatigue cracks due to low quality welds containing internal flaws or having rough surfaces.
- Investigating longitudinal stiffeners terminating in tension or stress reversal zones. These are fatigue prone details due to the sudden change in girder cross-sectional geometry.



- Investigating groove welds used to join the ends of web plates or different size flange plates in long spans. These welds may be ground flush or with the reinforcement left in place. In either case, though fatigue cracks are not normally expected to be found, poor welding or inspection may have left internal flaws within the weld metal, especially on older bridges.
- Examining lateral bracing member gusset plates groove-welded to tension flange edges or lapped and fillet welded to the tension flange. This is an outdated detail found on older bridges. These attachments should be inspected closely, as the gusset plates are details that are highly fatigue prone, similar to the ends of welded flange cover plates, and could have the potential for brittle fracture.
- Examining intersecting welds. High residual tensile stresses, internal flaws, and low fatigue strengths are created when welds intersect at attachments. Common intersecting weld locations are at longitudinal stiffener/transverse stiffener/web junctions and at horizontal gusset plate/vertical connection plate/web junctions.
- Examining intersecting welds found in haunched girders fabricated by groove welding the haunch plate to the web of a rolled shape. To fabricate this detail, the bottom flange of the rolled shape is cut off. This produces a re-entrant corner into which the haunch plate is welded. Since it is difficult to produce a quality weld at the short vertical length and at the groove weld intersection, fatigue cracks may develop at these locations. Similar details are found at insert plates used for web section loss repairs. In these repairs, square plates are fitted inside a square hole cut into the web. The plate edges are welded to the web, creating a patch. These patches contain intersecting welds and questionable groove weld terminations.
- Looking for welded repairs which increase the static strength of a member but greatly reduce the fatigue strength. These include patch plates fillet welded over heavily corroded areas (producing sudden geometric changes) and poor quality plug welds used to fill misdrilled bolt holes (plug weld cooling also creates high residual tensile stresses in the base material).
- Looking for out-of-plane bending cracks found in fabricated girders that are similar to those found on beam/diaphragm connections. These cracks occur at diaphragms, but may also occur at similarly detailed floor beam connections.
- Looking for out-of-plane bending cracks at horizontal web-gaps, which are the most common source of fatigue cracking in fabricated girders. Web gaps are created when the lateral bracing's horizontal gusset plate is notched to fit around a vertical connection plate and then welded to the girder web. Out-of-plane bending in this case is produced by forces originating from the lateral braces that push and twist the web. The connection plate and gusset greatly stiffen the web, and high bending stresses are generated in the relatively flexible gap between these two plates. The inspector should investigate the web gap on both sides of the connection plate, paying close attention to the toe of the weld along the connection plate and at the end of the horizontal gusset plate at the notch. Any crack will be oriented vertically at either of these two locations. Though not as common as at web-gaps, vertical cracks can develop at the ends of the gusset plates. Cracks that are close to, or propagated into the flange should be immediately reported to the Inspection Program Manager.

- Looking for out-of-plane bending cracks when superstructure girder flanges are welded directly to a cross girder web. Because intersecting groove or seal welds are used to create girder flange continuity through the cross girder web, a fatigue prone detail is created due to intersecting welds and weld flaws. In addition, high in-plane cross girder stresses combined with out-of-plane forces caused by the girder often lead to fatigue cracking.



Figure 2.4.4.1-2: Fabricated Girders and Rolled Cross-Frame Members.



Figure 2.4.4.1-3: Girder Failure Due to Brittle Cracking – Condition State 4.



Figure 2.4.4.1-4: Girder Failure Due to Brittle Cracking – Condition State 4.



Figure 2.4.4.1-5: Brittle Crack 3 Feet Long in a Girder Web 10 Feet Deep, Opposite of Lower Lateral Shelf Plate - Condition State 4.



Figure 2.4.4.1-6: Same Crack as shown in Figure 4.75, Inside Face of Girder at Lower Lateral Shelf Plate - Condition State 4.



Figure 2.4.4.1-7: Fatigue Crack at a Welded Cover Plate End (Rust Line within the Ground Area).

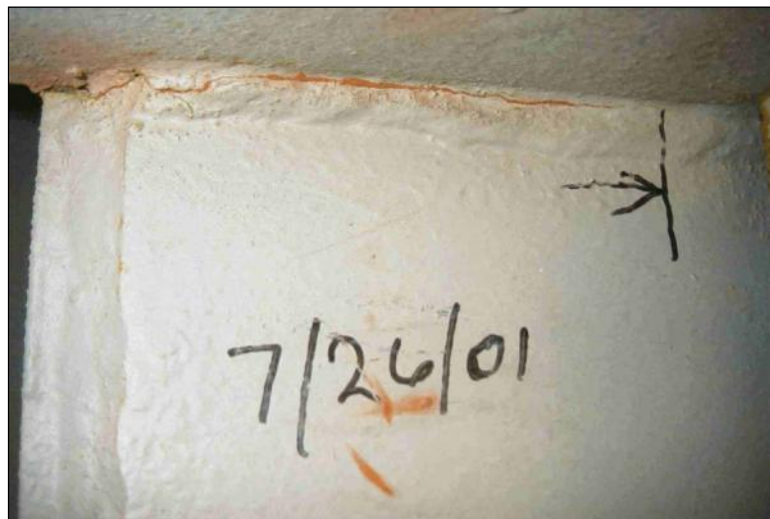

Figure 2.4.4.1-8: Rust Line at Weld Toe Indicating a Fatigue Crack.



Figure 2.4.4.1-9: Welded Girder to Cross Girder Connection Detail.

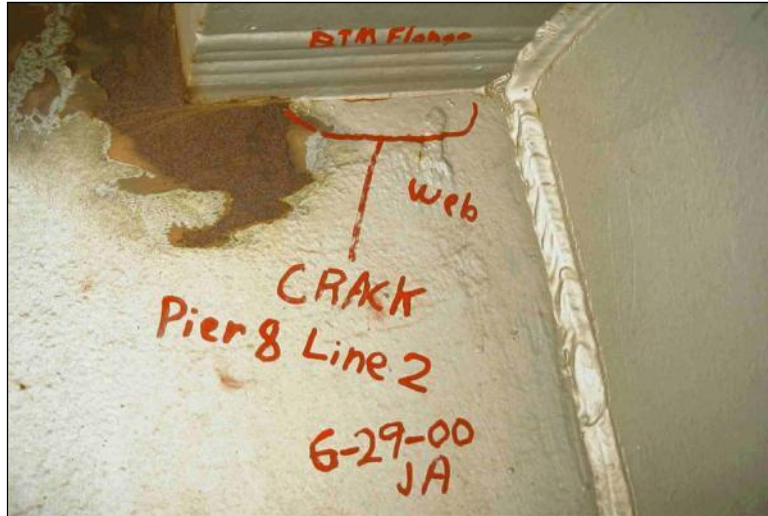

Figure 2.4.4.1-10: Fatigue Crack at the Girder Bottom Flange/Cross Girder Web Connection.



Figure 2.4.4.1-11: Fatigue Crack Through Girder Web Arrested with a Drilled Hole, Top of Connection Plate - Condition State 2.



Figure 2.4.4.1-12: Fatigue Crack at Flange/Web Intersection Arrested with Drilled Holes - Condition State 2.



Figure 2.4.4.1-13: Fatigue Crack at Flange/Web Intersection After Cleaning – Condition State 2.

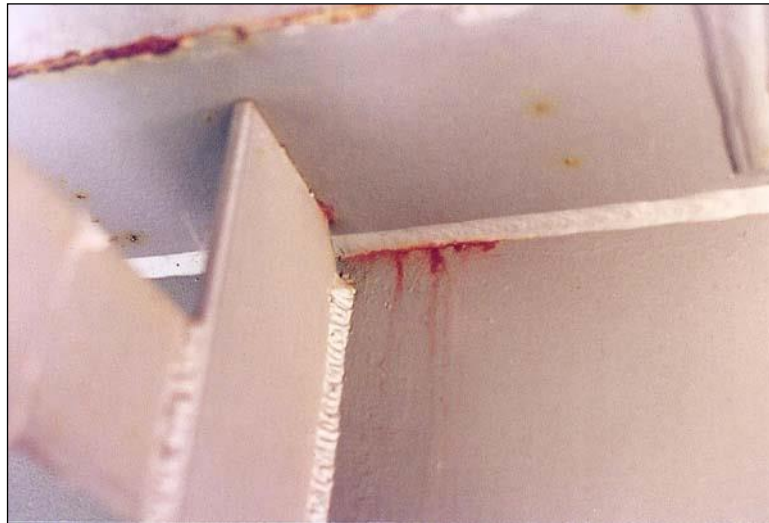

Figure 2.4.4.1-14: Fatigue Crack Indicated by "Fretting Corrosion" Rust Stains Along a Longitudinal Fillet Weld - Condition State 3.



Figure 2.4.4.1-15: Double Fatigue Cracks in Girder Web, Top of Connection Plate – Condition State 3.

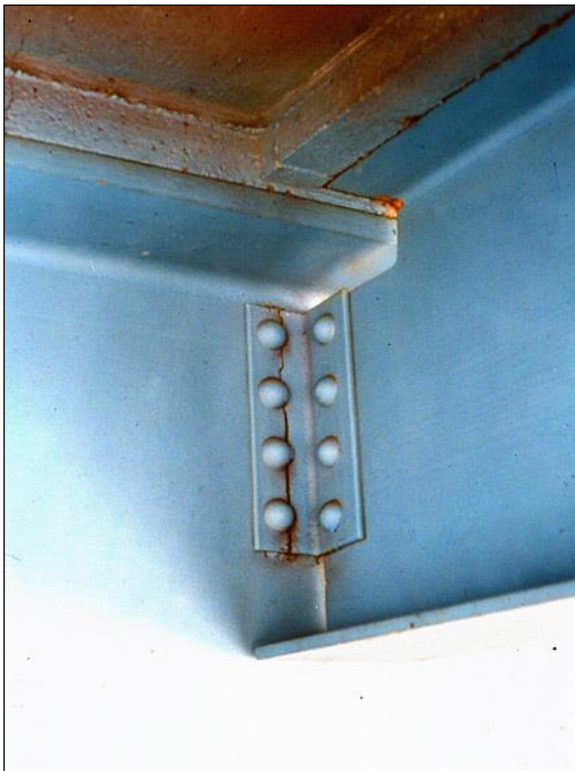

Figure 2.4.4.1-16: Fatigue Crack Through the Rivet Line of a Connection Angle - Condition State 3.



Figure 2.4.4.1-17: Unarrested Fatigue Crack - Condition State 3.

Box Girders: In-plane bending fatigue prone details on box girders are similar to those found on fabricated open girders. In addition, fatigue inspection in the flexural areas of steel box girders should include the following items:

- Investigating back-up bars that are butt-welded together end-to-end, or tack welded into place, and located within tension or stress reversal zones. These bars carry the same longitudinal stresses as the girder itself and may produce fatigue cracks due to low quality welds joining the bars or due to discontinuity of the bars.
- Investigating any web or flange longitudinal stiffeners that are welded together end-to-end and located within tension or stress reversal zones. Pay particular attention to all questionable details along the tension flanges.
- Checking for out-of-plane bending cracks. These cracks found in box girders are similar to those found on fabricated open girder connections. However, the forces in box girder diaphragms/cross-frames may carry higher loads than those of open girders, and out-of-plane fatigue cracking is more likely.
- Checking all welded attachments inside the box including the transverse stiffeners, cross-frames, diaphragms, lateral bracing (including web-gaps), and stay-in-place deck panels.
- Checking the ends of all partial depth diaphragm connections sometimes found inside of arch tie girders. These diaphragms are placed in line with the floor beams, and bending moments at the floor beam connection push or bend the tie girder web sideways between the flanges and diaphragm. Damage typically shows up as a U-shaped crack around the diaphragm connection plate end or as a horizontal crack near the flange/web weld.



Figure 2.4.4.1-18: Steel Box Girders - Condition State 1.

Floor System Components: In-plane bending fatigue prone details may be present on stringers and floor beams. To facilitate erection and connection fit-up, stringers and floor beams may have cut flanges, copes, or blocked flange plates at their ends. High, localized stresses can result due to the abrupt change in cross-sectional geometry. In addition, cut flanges and copes may have sharp re-entrant corners rather than smooth transitions, creating stress risers. These details may also have been torched, leaving rough edges or notches.

Fatigue inspection of floor system components should include the following items:

- Closely looking at re-entrant corner details near the tension flange. Cracks will typically start at these locations, propagating into the web.
- Checking for stiffeners that may be erroneously welded to a tension flange, creating a stress riser. Bearing stiffeners are common on floor beams and stringers. Carefully check the welds and flange on these floor system components for cracks.
- Looking for out-of-plane bending cracks. These cracks may occur in the webs of floor beams and in the webs of their associated cantilever brackets. Cracking may take place when the stringers rest on the floor beam's top flange and the girder top flange is not embedded in the deck. A tie plate provides continuity between the floor beam and bracket top flanges but is not welded to the girder top flange. Deflection of the girder relative to the floor beam bends the floor beam/bracket web sideways, producing fatigue cracks near the top flange. This same type of cracking may occur in the floor beam connection to the girders of arch bridges and to truss lower chords..



Figure 2.4.4.1-19: Fabricated Steel Girders and Floor Beams, and Rolled Stringers.

Riveted and Bolted Members: Though welded structures are most often associated with fatigue concerns, mechanically fabricated members are also susceptible to fatigue damage. Vulnerable locations are essentially the same for welded and riveted members, that is, at

connections. Damage is most likely to be found at the ends of members with simple supports provided by connection angles. Because these types of connections carry a small amount of bending, moments are applied to the connection angles, and prying forces are applied to the rivets and bolts passing through the angle's outstanding legs (legs perpendicular to the member being connected).

Fatigue inspection of riveted and bolted members should include the following items:

- Investigating the fasteners. Fasteners closest to the ends of the connection angles are subjected to the highest prying force and cyclic loading may cause the fastener shank to fail in fatigue. Signs of fatigue include fretting corrosion/rust powder under the fastener head or nut, gaps between the connected parts and the fastener head or nut, a dull sound when the head is tapped with a hammer or a missing fastener.
- Investigating the connection angles. Fatigue cracks can be found in the connection angles either in the angle's outstanding legs or in the parallel legs (legs parallel to the member being connected). Cracks will usually originate near the angle's fillet at one end of the angle. The same type of fastener and angle failures may also occur at diaphragm/cross-frame connections.
- Looking for out-of-plane bending damage in the girder web adjacent to floor beam connections. This usually occurs at web-gaps created when transverse or longitudinal stiffeners use a separate row of fasteners than those used to join the connection angles to the web.
- Checking for cracks that may occur in the webs of floor beams and in the webs of their associated cantilever brackets. This is a detail similar to that found on welded floor systems. Cracking may take place when the stringers rest on the floor beam's top flange and the girder top flange is not embedded in the deck. A tie plate provides continuity between the floor beam and bracket top flanges, but is not fastened to the girder top flange. Relative deflection of the girder to the floor beam bends the floor beam/bracket web sideways, producing fatigue cracks near the top flange. This same type of cracking is seen in the floor beam connection to truss lower chords.





Figure 2.4.4.1-20: Sheared Off Diaphragm Bolts Due to Fatigue.

Miscellaneous: Fatigue inspection of miscellaneous components should include the following item:

- Looking for stress risers on tension flanges such as tack welds, gouges, and indiscriminately placed attachment welds. These may occur on any welded or riveted/bolted member listed above. Flaws such as these should be marked, recorded, and ground smooth. Until the areas are repaired, the member should be closely monitored to spot crack development.

Element Defects

Refer to Appendix A for Defect descriptions. The defects listed are unique to the element and element material (i.e. concrete, steel, timber, etc.).

- Corrosion (1000)
- Cracking (1010)
- Connection (1020)
- Distortion (1900)

Condition State Commentary

Elements exhibiting damage should report the damage in the note of the report under the defect associated with the damage. For instance, the bottom flange of a beam is struck by vehicular traffic and exhibits deformation out-of-plane. The defect would be reported under Distortion (1900) with the note indicating the deformation was caused by traffic impact.

Overload damage (buckled compression member or member element, yielded tension member or member component, crippled web at a support) and heat damage are not addressed as defects. The omissions should not be interpreted as meaning overload and heat damage are minor defects. On the contrary, overload damage and heat damage are significant defects that can be as severe as fatigue cracks. The inspector should document this type of damage in writing under the *Structural Notes* dialog box near the end of the Field Bridge Inspection Report form and notify the Program Manager immediately.

If excessive debris is present on the flanges, cleaning should be recommended under *Maintenance Actions*.

The inspector is responsible to carry all necessary equipment to make accurate measurements if necessary. Concrete Condition States are dependent on crack width and spall dimensions and depth.

The defects and condition state definitions are based on the AASHTO Manual for Bridge Element Inspection.

Appendix A defines the Condition States for each individual defect. The defects are expounded on and critical areas are discussed to aid the inspector in determining the

severity of a defect. The WisDOT Bridge Inspection Field Manual tabulates the element defects listed above and bases the Condition States on the progression of severity for each defect. The Condition States are comprised of general descriptions and uniquely colored to follow the severity the description represents.

- Condition State 1 Good Green
- Condition State 2 Fair Yellow
- Condition State 3 Poor Orange
- Condition State 4 Severe Red



Figure 2.4.4.1-21: Weathering Steel Girders with Scaling on the Bottom Flanges – Condition State 3.



Figure 2.4.4.1-22: Steel Girders – Corrosion Condition State 2.



Figure 2.4.4.1-23: Girder – Corrosion Condition State 2.



Figure 2.4.4.1-24: Steel Girder – Corrosion Condition State 2.



Figure 2.4.4.1-25: Steel Girder – Corrosion Condition State 2.



Figure 2.4.4.1-26: Pack Rust at Bolted Girder Bottom Flange Field Splice – Connection Condition State 2.



Figure 2.4.4.1-27: Impact Damage to a Girder Bottom Flange – Distortion Condition State 2.



Figure 2.4.4.1-28: Impact Damage to Bottom Flange of a Two-Girder Bridge – Distortion Condition State 2.



Figure 2.4.4.1-29: Pit Caused by Section Loss on Girder Bottom Flange – Corrosion Condition State 3.



Figure 2.4.4.1-30: Steel Girders – Corrosion Condition State 3.



Figure 2.4.4.1-31: Steel Girders – Corrosion Condition State 3.



Figure 2.4.4.1-32: Section Loss on Girder Web Painted Over – Corrosion Condition State 3.

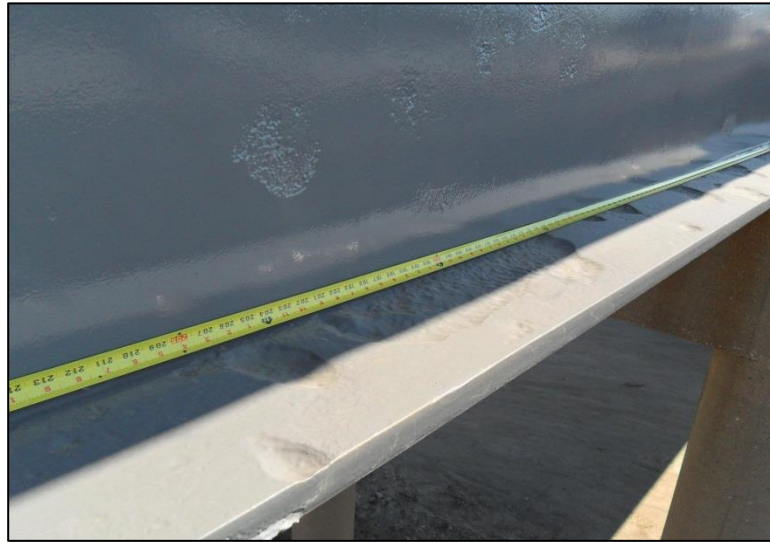

Figure 2.4.4.1-33: Severe Pitting Along Bottom Flange Painted Over – Corrosion Condition State 4.



Figure 2.4.4.1-34: Laminate Section Loss of Web – Corrosion Condition State 4.



Figure 2.4.4.1-35: Steel Rolled Beams – Corrosion Condition State 4.



Figure 2.4.4.1-36: Steel Beam – Corrosion Condition State 4.



Figure 2.4.4.1-37: Through Thickness Section Loss of a Rolled Beam Web - Condition State 4.



Figure 2.4.4.1-38: Heavy Pack Rust (Painted Over) at a Multiple Plate Bearing Stiffener – Connection Condition State 4.



Figure 2.4.4.1-39: Impact Damage to Exterior Girder – Distortion Condition State 4.



2.4.4.2 Steel Cable – Primary (Element 147) Steel Cable – Secondary (Element 148)

These elements are for all cable groups regardless of protective system. These steel elements are tension only members used in suspension, cable-stayed, post-tensioned concrete and tied arches.

Cables may be used as vertical suspenders, angled cable stays, catenaries or post-tensioning strands. Unlike solid rods, many individual wires are helically spun together, placed parallel to each other, or spun into rope to build up the size of the cable. End anchorages are usually made by brooming or spreading apart the cable wires inside a steel fitting. The conical-shaped steel fitting is then filled with a socketing medium, such as molten zinc, to lock the wires in place. Another anchoring method for smaller diameter cables or individual strands is the placement of jaws (wedges) around the strand. These jaws grip and anchor the strand as the strand is pulled and seated into a conical-shaped anchor block.

The most common method used to coat cables/rods for corrosion protection is galvanizing the individual cable wires or rods. Painting is another method. However, paint's effectiveness for corrosion protection of cables is questionable due to its inherent brittleness coupled with the cable's flexibility. Flexible proprietary coatings are also used. These "caulk-like" products never completely harden, thereby allowing a cable to deflect or vibrate without cracking or chipping the coating. These coatings may also be used to fill the voids between the cable wires during the manufacturing process. On large suspension bridge main cables, a zinc dust paste (in earlier days lead paste) is typically spread onto the outside perimeter of the cable and then tightly wrapped with a galvanized steel continuous band. On some cable-stayed bridges and post-tensioned concrete boxes, the cables/rods may be wrapped with a plastic tape. Cables may be covered with a polyethylene tube. Grout, grease, or mastic material is often used to fill the voids between the element and the wrapping tape or tube. These coating systems, however, do not allow for the direct inspection of the elements and have a tendency to trap moisture.

Primary cables include all main suspension (catenary cable) or cable stay cables not embedded in concrete.

Secondary cables include suspender cables (under the catenary cable) or other groups of cables that carry superstructure (deck or girder) loads to the main load carrying cable or arch.

These cables do not include moveable bridge cables. The assessment Moveable Bridge Cables (9021) shall be used to capture issues with equalizer or lifting cables on moveable bridges. Refer to Chapter 7, Part 2 for additional information on Assessments.

Secondary cables are secondary elements. Observed failures should be noted within the Inspection Report form. However, it will not significantly impact the structural integrity of the superstructure. Remedial actions will need to be taken to repair the failure, as the secondary members are responsible for transferring loads. A missing element may, in time, result in unwarranted stresses within the primary structural members.



Element Level Inspection

Corrosion is the primary concern to any steel cable and has a more profound structural effect on cables than it does on solid elements. Because cables have a much greater surface area than a solid rod with the same cross-sectional area, surface corrosion on the wires will reduce a cable's cross-sectional area more than on a solid element. For example, a cable containing 153 – 0.162 inch diameter wires has about the same area as a solid 2-inch diameter bar (3.14 square inches). If corrosion removes 1/32 inch of thickness from all steel surfaces, the remaining cable area would be 1.19 square inches (a 62 percent reduction in area), and the remaining solid rod area would be 2.95 square inches (a 6 percent reduction in area). It is clear that corrosion can have a serious effect on the load-carrying capacity of cable elements.

Since cables are made up of many individual wires, only about 10 percent of the total wire surface area can be seen during a routine inspection. Voids between the interior wires can trap moisture. The inspector must therefore assume that the same corrosion severity that can be seen on the cable's surface exists on the interior wires as well.

On the inspection report form, cable elements are recorded in units of "each". This is because cable removal/replacement is normally required when severe deterioration exists (except for suspension bridge main cables). For each cable, it is the inspector's task to assign the most appropriate defect Condition State to the entire element. This will quantify the element's surface condition and help generate quantity/cost estimates for future remedial work. If multiple defects are found within the same unit of measure, the inspector shall record the predominant defect on the inspection report and describe other defects within the notes under the element. The predominant defect is determined first by Condition State. If Condition States are equal, the hierarchy then falls to the lowest associated defect number.

Maintenance inspection of cables should include the following items:

- Looking for broken wires. Broken wires may be caused by pack rust due to bending near the anchorages, excessive section loss due to corrosion, or abrasion against the cable guide due to wind induced vibrations.
- Indicating on the report if the cables are vibrating excessively due to wind, and noting the cable's amplitude, wind speed, and wind direction.
- Checking for cable loosening or slippage at the end fittings. Signs of this condition may be wire abrasion and/or corrosion having an orange to light brown color with a dusty appearance.
- Inspecting the lower end fittings for excessive cable corrosion where water would tend to accumulate, as well as for any cracks in the casting.
- Noting any slipping or unraveling of the main cable banding on suspension bridges.
- Reporting severe corrosion that has formed pack rust between individual wires or between the wires and end fittings.

Large suspension and cable-stayed bridges are individually unique and will normally have their own operation and maintenance manuals to guide the inspector during routine



evaluations. There are many components which make up these structures. Due to their scarcity in Wisconsin, the inspection of these components will not be discussed here. The reader is referred to Federal Highway Administration (FHWA) publication *Safety Inspection of In-Service Bridges Participant Notebook* (two-week training course) for additional guidance.

Overload damage (yielded cable or cable pulled out of its anchorage) and heat damage are significant defects that can be as severe as fatigue cracks. The inspector should document this type of damage in writing under the *Structural Notes* dialog box located near the end of the Field Bridge Inspection Report form, and notify the Program Manager immediately.

Element Defects

Refer to Appendix A for Defect descriptions. The defects listed are unique to the element and element material (i.e. concrete, steel, timber, etc.).

- Corrosion (1000)
- Cracking (1010)
- Connection (1020)
- Distortion (1900)

Condition State Commentary

Elements exhibiting damage should report the damage in the note of the report under the defect associated with the damage.

The inspector is responsible to carry all necessary equipment to make accurate measurements if necessary. Concrete Condition States are dependent on crack width and spall dimensions and depth.

The defects and condition state definitions are based on the AASHTO Manual for Bridge Element Inspection.

Appendix A defines the Condition States for each individual defect. The defects are expounded on and critical areas are discussed to aid the inspector in determining the severity of a defect. The WisDOT Bridge Inspection Field Manual tabulates the element defects listed above and bases the Condition States on the progression of severity for each defect. The Condition States are comprised of general descriptions and uniquely colored to follow the severity the description represents.

- Condition State 1 Good Green
- Condition State 2 Fair Yellow
- Condition State 3 Poor Orange
- Condition State 4 Severe Red



Figure 2.4.4.2-1: Cable Coated with a Flexible Resin System – Condition State 1.



Figure 2.4.4.2-2: Galvanized Steel Cable – Condition State 1.



Figure 2.4.4.2-3: Cable Anchorage for a Tied Arch Bridge – Condition State 1.



Figure 2.4.4.2-4: Galvanized Steel Cable Exhibiting Freckled Rust – Corrosion Condition State 2.



Figure 2.4.4.2-5: Cable Anchorage for a Cable Stayed Bridge – Connection Condition State 2.



2.4.4.3 Steel Tension Rods/Post-Tensioned Cables (Element 8165)

Tension rods are most often used to strengthen concrete elements as a retro-fit. They are commonly installed on the exterior of the element. Post-tensioned cables are most often used to prestress concrete box girder bridges. This keeps the girder cross-section in compression under all loads, thereby eliminating cracking. This results in a girder much stiffer and stronger than a cracked/conventionally reinforced concrete girder. These elements are also used to transversely post-tension timber slab bridges, or other plank-type superstructure panels. Post-tensioning transverse to the roadway creates friction, allowing the many individual panels or boards to act as a unit.

Normally, only the ends of the rods are visible for inspection, although early examples of post-tensioned concrete box girders left the entire rod exposed within the cells.

This element does not include the suspender cables or rods on tied-arch structures. Those members shall be evaluated under the Steel Cable – Secondary (Element 148).

Two methods are commonly used to anchor the ends of the rods or cables. For rods, their ends are threaded. After jacking the rod into tension, a bearing nut is screwed onto the threaded end tight to the anchorage plate, and the jack released. Cables will often use a wedge system for anchorage. Cables pass through a special anchorage plate with conical-shaped holes. After jacking the cable into tension, cone-shaped wedges are placed around the cable, and the jack released. Relaxation of the cable draws the wedges into the conical shaped anchorage holes, locking the cable in place.

Element Level Inspection

On the inspection report form, tension rod/post-tensioned cable elements are recorded in units of “each”. For each rod or cable, it is the inspector’s task to assign the most appropriate defect Condition State to the entire element. This will quantify the element’s condition and help generate quantity/cost estimates for future remedial work. If multiple defects are found within the same unit of measure, the inspector shall record the predominant defect on the inspection report and describe other defects within the notes under the element. The predominant defect is determined first by Condition State. If Condition States are equal, the hierarchy then falls to the lowest associated defect number.

Element Level Inspection of tension rods/post-tensioned cables should include the following items:

- Looking at the anchorages for lack of bearing or slip of the cable through the wedge. Sudden losses of force may allow the rod/cable to snap and shoot out of the anchorage.
- Pulling/shaking rod ends to check for looseness. Looseness indicates a complete loss of prestressing force and element effectiveness.
- Lightly tapping the tensioned length of the rod/cable (if accessible) with a rubber mallet. Similar to the strings of a guitar, tensioned elements should ring, while un-tensioned elements will produce a dull thud. As an alternative, the rods/cables may



be shaken. Tensioned elements should be taught, while un-tensioned elements move easily.

- Looking for corrosion and its extent. Severe corrosion will produce section loss and an increase in tensile stresses.
- Looking for broken rods/cables. Broken elements may be caused by excessive corrosion that had caused overstresses. Corrosion may also cause section loss on the threads at the ends of a rod. This can cause the anchorage nuts or couplers to slip.
- Inspecting the anchorage nuts for cracks or other damage.

Element Defects

Refer to Appendix A for Defect descriptions. The defects listed are unique to the element and element material (i.e. concrete, steel, timber, etc.).

- Corrosion (1000)
- Cracking (1010)
- Connection (1020)
- Distortion (1900)

Condition State Commentary

Elements exhibiting damage should report the damage in the note of the report under the defect associated with the damage.

The inspector is responsible to carry all necessary equipment to make accurate measurements if necessary. Concrete Condition States are dependent on crack width and spall dimensions and depth.

The defects and condition state definitions are based on the AASHTO Manual for Bridge Element Inspection.

Appendix A defines the Condition States for each individual defect. The defects are expounded on and critical areas are discussed to aid the inspector in determining the severity of a defect. The WisDOT Bridge Inspection Field Manual tabulates the element defects listed above and bases the Condition States on the progression of severity for each defect. The Condition States are comprised of general descriptions and uniquely colored to follow the severity the description represents.

- Condition State 1 Good Green
- Condition State 2 Fair Yellow
- Condition State 3 Poor Orange

- Condition State 4 Severe Red



Figure 2.4.4.3-1: Exposed Post Tensioning Rods Inside of a Concrete Box Girder - Condition State 1.

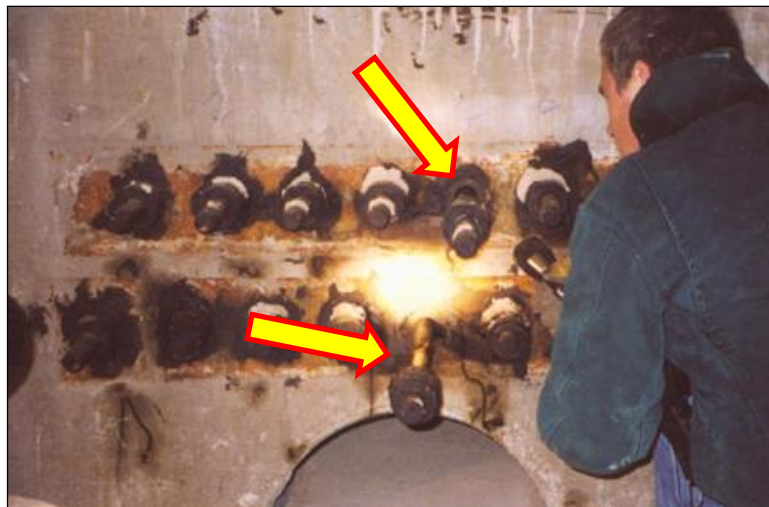

Figure 2.4.4.3-2: Post-Tensioning Rods (2) Protruding from the Anchorage, Indicating a Loss of Prestressing Force – Connection Condition State 3.



Figure 2.4.4.3-3: Protruding Post-Tensioning Rod – Connection Condition State 3.



Figure 2.4.4.3-4: End of Post-Tensioning Rod with Cracked Nut – Connection Condition State 3.

2.4.4.4 Steel Truss (Element 120)

This element encompasses all steel truss elements. This includes all tension and compression primary members throughout the truss.

The components included under this element are primary load-carrying members, and bracing members in certain circumstances, and are theoretically loaded in either pure tension or compression. Members carrying tensile loads are NSTMs. Though each of these members may contain internal redundancy (multiple eyebars or built-up riveted shapes) this fact should not be neglected and each element of the member inspected as a NSTM.



Figure 2.4.4.4-1: Truss Bottom Chord.

On simply supported trusses, the bottom chords are NSTMs. On continuous trusses, both the bottom chord and top chord are NSTM, depending on their location relative to the pier. Bottom chords are in tension and therefore NSTM between the substructure elements. Top chords are in tension and therefore NSTM above the piers.

Element Level Inspection

On the inspection report form, trusses are recorded in units of lineal feet. A steel truss bridge will have at least two trusses. The correct method to calculate the quantity is to sum of all lengths of each panel as measured longitudinally along the travel way. This element includes all primary components in plane with the truss including, the bottom chord, top chord, verticals and diagonals, as well as bracing member above the roadway on through trusses. The truss components may exhibit more than one Condition State along its length. Distress observed on vertical, diagonal or bracing members shall be reported as the length projected along the length of the truss. Where multiple condition states exist within a unit of measure only the predominant defect in severity and extent is recorded. The other defects located within the unit of measure shall be captured by the inspector under the element or appropriate defect notes. The sum of all of the reported condition states must equal the total



quantity of the element. This will quantify the element's condition and help generate quantity/cost estimates for future remedial work.

Through trusses contain overhead lateral and vertical sway bracing. For through trusses *or through arches*, the upper bracing (lateral, vertical, portal, and sway) above the deck will be evaluated and coded under Assessment 9170 – Truss or Arch Overhead Bracing System. All lateral bracing below the deck will be evaluated under assessment 9169 Lateral Bracing. Refer to Chapter 7, Part 2 for additional information on Assessments. The upper bracing supports the compression members of the truss stabilizing thus making them important members. Its failure could result in the buckling of the compression chord of the truss.

Deck trusses have no bracing located above the roadway. All bracing on deck trusses shall be evaluated as assessment 9169 Lateral Bracing. Refer to Chapter 7, Part 2 for additional information on Assessments.

Truss bottom chord members are located below the deck, exposing them to water, deicing chemicals, roadway debris, and occasionally drift impact from streams below during high water events. The top chord, vertical, and diagonal members are exposed to a less severe environment (except for deck trusses), but are still susceptible to traffic impact and water and deicing agents.

Safety Inspection

During the Element Level Inspection of truss members, it is important for the inspector to remember that the entire purpose of a bridge inspection is to ensure public safety. A structural inspection must also be carried out, regardless of the coating condition. The main purpose of a truss is to transmit loads to the substructure. A structural failure of one of a truss' NSTMs could mean a total bridge collapse. The following will serve as a guide for the inspector of what to look for and where to look for it while examining one of these members. This will also help the inspector judge a member's ability to carry the design loads and identify current or future structural problems.

Tension Members: It is required that tension members be identified prior to performing a NSTM Inspection. It is also advantageous to identify tension members for Routine Inspection. On simply supported trusses, the bottom chords will always be in tension, similar to the bottom flange of simply supported beams/girders. On continuous trusses, the top chord will be in tension over the piers, and the bottom chord is in tension between supports. Again, this is analogous to the top and bottom flanges of continuously supported beams/girders. On simply supported trusses, diagonals that point upward and away from midspan are tension members, as well as any counters which form an "X" pattern at or near midspan. There is no easy method to determine which diagonals are in tension of continuously supported trusses and vertical members of any truss. This determination is made during the NSTM inspection preparation phase and should not be done in the field.

Maintenance inspection of truss tension members should include the following items:

- Examining all tension components for corrosion and loss of cross-sectional area, which is the most common steel defect.



- Removing spot areas of debris accumulation to check for corrosion. Bird waste that is often found on the horizontal surfaces is acidic and traps moisture and road salts, accelerating corrosion.
- Checking for corrosion, not only on the primary member components, but also on members used to build up the primary members such as lacing bars and batten plates.
- Closely examining eyebar heads for corrosion, lack of movement, and cracking at the forging location.
- Checking rivet/bolt heads on built-up components. Corrosion on the heads may indicate corrosion along the entire fastener length, reducing structural integrity.
- Looking for pack rust, noted by individual plate bending between fasteners. Pack rust may be present between the plies of riveted/bolted connections such as lacing bars, batten plates, gusset plates, or field splices.
- Checking to make sure all eyebars of a multiple eyebar member are parallel to one another. This suggests that the loads are evenly distributed. Unintended bending and compressive stresses may be introduced into a tension member from substructure settlement or heavily rusted/frozen pinned joints. Signs of this are bowed or buckled tension members. The inspector should look for overloads on other members when this situation is encountered, since loads previously carried by the tension member must be redistributed somewhere else within the bridge.
- Checking all pins for excessive wear.
- Checking to see if pin spacers are keeping the eyebars or loop rods properly aligned and symmetric about the truss plane.
- Examining the condition of threaded members such as truss rods at turnbuckles.
- Checking suspect fasteners for looseness by twisting by hand or tapping the heads with a hammer.
- Looking for member distortion or scraping from traffic impacts.

Compression Member: On simply supported trusses, the top chords will always be in compression, similar to the top flange of simply supported beams/girders. On continuous trusses, the bottom chord will be in compression over the piers, and the top chord is in compression between supports. Again, this is analogous to the bottom and top flanges of continuously supported beams/girders. On simply supported trusses, diagonals which point downward and away from midspan are compression members. There is no easy method to determine which diagonals of continuously supported trusses and vertical members of any truss are in compression. This determination is made during the NSTM Inspection preparation phase and should not be done in the field.

Maintenance inspection of truss compression members should include the following items:



- Checking compression members for corrosion damage.
- Removing spot areas of debris accumulation to check for corrosion. Bird waste that is often found on the horizontal surfaces is acidic and traps moisture and road salts, accelerating corrosion.
- Looking for pack rust, noted by individual plate bending between fasteners. Pack rust may be present between the plies of riveted/bolted connections such as lacing bars, batten plates, gusset plates, or field splices.
- Looking for compression overload damage in the form of local member element buckling or plate distortion. Global buckling will take the form of a bowed member or a member bowed into an “S” shape if a point support is provided between its ends.
- Checking suspect fasteners for looseness by twisting by hand or tapping the heads with a hammer.
- Looking for member distortion or scraping from traffic impacts.

Safety Inspection - Fatigue

Truss tension members are susceptible to fatigue damage. Fatigue cracks usually show up as rust stains or rusty breaks in the paint, propagating perpendicular to the direction of stress.

The following text attempts to summarize locations for fatigue prone details and what the inspector should examine on truss tension members. Nonetheless, it is strongly recommended that the inspector become familiar with the *Manual for Inspecting Bridges for Fatigue Damage Conditions*, as this reference will have more complete information on the topic. Any fatigue related damage found should be recorded under Condition State 4 and the Program Manager notified immediately.

Eyebars and Loop Rods: These are pin-connected members. Many old eyebars were fabricated by forging cast eyebar heads to a rolled bar which formed the eyebar body. Loop rods are a very old style of tension member. The loops were formed by heating and bending the rod ends, then forging the free end back onto the body.



Figure 2.4.4.4-2: Multiple Eyebars Connected with a Pin.

Fatigue inspection of eyebars and loop rods should include the following items:

- Checking for fatigue cracking at the forge zones, as well as at the eyebar head to body transition when the bar edge is flame cut. When the pins are heavily corroded and appear to have locked up eyebar or loop rod movement, transverse cracks may appear in the member body away from the forge zone or in the eyebar head. This is due to unintended bending moments are being introduced into the member.
- Examining plates or attachments that connect two or more eyebars by welding. Cracks found in the weld material can readily propagate into the eyebar base metal.

Riveted Built-up Members: The primary cause of fatigue cracks in these members occurs when their ends are pin-connected. Heavily-corroded pins have friction and, as a result, large, unintended bending stresses may be introduced to the member.

Fatigue inspection of riveted built-up members should include the following items:

- Closely inspecting all surfaces for fatigue cracks on tension members and on the hangers of cantilevered trusses. Fatigue cracks are most likely to form at areas of stress concentrations such as rivet holes.

Miscellaneous: For any welded or riveted/bolted tension members listed above, fatigue inspection should include the following items:

- Looking for stress risers in the form of welded repairs or reinforcement plate attachments. Welded reinforcement plate attachments have one of the lowest fatigue strengths of any detail.
- Closely examining areas of heavy corrosion and section loss that can also act as notches and stress risers.



- Checking defects such as tack welds, gouges, and indiscriminately placed attachment welds. Welds made to old steel that is not very weldable have a tendency to cause cracking in the base metal. These defects should be ground smooth or closely monitored to spot crack development.

Element Defects

Refer to Appendix A for Defect descriptions. The defects listed are unique to the element and element material (i.e. concrete, steel, timber, etc.).

- Corrosion (1000)
- Cracking (1010)
- Connection (1020)
- Distortion (1900)

All defects on gusset plates connecting bracing below or above the deck on through trusses would be recorded under the assessment notes for 9169 Lateral Bracing if below or 9170 Truss or Tied/Arch Portal Bracing if above. Defects found on gusset plates within the plane of the truss would be captured under the appropriate defect under the Steel Gusset Plate element 162.

Condition State Commentary

Elements exhibiting damage should report the damage in the note of the report under the defect associated with the damage. For instance debris impact observed along the bottom chord of the truss would be recorded under defect Distortion 1900. The inspector would note in the defect notes that the distortion was caused by debris impact.

The inspector is responsible to carry all necessary equipment to make accurate measurements if necessary. Concrete Condition States are dependent on crack width and spall dimensions and depth.

The defects and condition state definitions are based on the AASHTO Manual for Bridge Element Inspection.

Appendix A defines the Condition States for each individual defect. The defects are expounded on and critical areas are discussed to aid the inspector in determining the severity of a defect. The WisDOT Bridge Inspection Field Manual tabulates the element defects listed above and bases the Condition States on the progression of severity for each defect. The Condition States are comprised of general descriptions and uniquely colored to follow the severity the description represents.

- Condition State 1 Good Green
- Condition State 2 Fair Yellow
- Condition State 3 Poor Orange

- Condition State 4 Severe Red



Figure 2.4.4.4-3: Diagonal Truss Member Exhibiting Rust with No Loss of Section – Corrosion Condition State 2.



Figure 2.4.4.4-4: Batten Plate on Truss Bottom Chord – Connection Condition State 4.



Figure 2.4.4.4-5: Truss Bottom Chord (Note Impact Damage) – Distortion Condition State 2.



Figure 2.4.4.4-6: Impact Damage to a Truss Sway Strut – Distortion - Condition State 2.



2.4.4.5 Steel Gusset Plate (Element 162)

Gusset plates are used to connect several superstructure members together. They are commonly used on trusses and arches and may connect primary or secondary members together. They are constructed of steel plate and may be arranged in pairs or as a single plate. The superstructure members are fastened to the gusset plate by way of welds, bolts, rivets, or a combination. Plate shapes are usually atypical. A gusset plate typically connects three to five members together at a point.

Gusset plates are considered NSTMs when they connect one or more NSTM together. See Section 2.4.4.8 NSTM Steel Superstructure Inspection for more information on NSTMs.

Element Level Inspection

On the inspection report form, gusset plates are recorded in units of each. The correct method for calculating the total quantity is the sum of the number of primary load path gusset plate assemblies. Only those steel gusset plate(s) connections that are on the main truss/arch panel(s). For multiple plate gusset connections at a single panel point, the quantity shall be one gusset plate regardless of the number of individual plates at the single connection point. Gusset plates connecting lateral or sway bracing below or above the deck are not included in this quantity and shall be recorded under the assessment 9169 Lateral Bracing if below or 9170 Truss or Tied/Arch Portal Bracing if above. Any defects found on these gusset plates shall be noted under the assessment notes and used in evaluating the overall assessment (EA).

Where multiple condition states exist within a unit of measure only the predominant defect in severity and extent is recorded. For a gusset plate, only one defect will be applied to each gusset assembly. Therefore it is the inspector's responsibility to determine the predominant defect for the entire assembly. The other defects located within the unit of measure shall be captured by the inspector under the element or appropriate defect notes. The sum of all of the reported condition states must equal the total quantity of the element. This will quantify the element's condition and help generate quantity/cost estimates for future remedial work.

If multiple defects are found within the same unit of measure, the inspector shall record the predominant defect on the inspection report and describe other defects within the notes under the element. The predominant defect is determined first by Condition State. If Condition States are equal, the hierarchy then falls to the lowest associated defect number.

Gusset plates may be comprised of several components, including built-up sections, filler plates or angles for fastening to primary members. Asymmetric plate shapes are also common to accommodate different sized members and orientations. For this reason gusset plates undergo very complex reactions and as such, require very careful and detail oriented inspections.

Element level inspection of gusset plates should include the following items:

- Examining the connections to the truss to check for loose, corroded, or missing fasteners, cracked welds, and fatigue cracks. The inspector should take note of any tack welds that may be present on the gusset plate as these are fatigue prone details. Partially cracked tack welds pose a large threat for crack propagation into the base metal. Fully cracked tack welds with no evidence of base metal cracking are not



problematic. Fatigue cracking in gusset plates is commonly found at rivet holes. Rivet holes are punched rather than drilled resulting in overstressing of the surrounding plate material.

- Checking suspect fasteners for looseness by twisting by hand or tapping the heads with a hammer. Loose fasteners or connections may be the result of an overload that caused excessive tension forces in the member.
- Checking corroded areas for excessive section loss that may be increasing member stress. Particular attention should be given to areas near the roadway where connections to horizontal surfaces can trap water and deicing agents.
- Removing spot areas of debris accumulation to check for corrosion. This is especially true on truss connections where the bottom chord is plated allowing debris to build up and come into contact with the lower chord gusset plates. Bird waste that is often found on these elements is acidic and traps moisture and road salts, accelerating corrosion.
- Checking repairs and retrofits. Welded retrofits are extremely problematic and are prone to fatigue cracking at the welds. Inspect all plate layers for pack rust and distortion.
- Inspecting of the gusset plate and its connecting member for distortion, such as a bow, sweep, or kink. This distortion may occur in the plate between the end row of fasteners of one member and an adjacent row of fasteners in another member. This is called the free edge of the gusset plate. This would suggest a structural overload, or flexural bending and further investigation of the primary load-carrying members should be carried out. Plate distortion may also be induced by pack rust between members or plates.

Element Defects

Refer to Appendix A for Defect descriptions. The defects listed are unique to the element and element material (i.e. concrete, steel, timber, etc.).

- Corrosion (1000)
- Cracking (1010)
- Connection (1020)
- Distortion (1900)

All defects on gusset plates not in the plane of the truss and not connecting the portal members to the truss end posts shall be recorded under defect Connection 1020 on the Steel Truss element 120. Defects found on gusset plates in the plane of the truss or connecting portal members to the truss end posts shall have the defects captured under the appropriate defect on the Steel Gusset Plate element 162. Gusset plates connecting bracing below the roadway on through trusses or all deck trusses would be recorded under the assessment notes for 9169 Lateral Bracing.



Condition State Commentary

Elements exhibiting damage should report the damage in the note of the report under the defect associated with the damage. For instance debris impact observed on a gusset plate of the bottom chord of the truss would be recorded under defect Distortion 1900 under the Steel Gusset Plate element. The inspector would note in the defect notes that the distortion was caused by debris impact.

The inspector is responsible to carry all necessary equipment to make accurate measurements if necessary. Concrete Condition States are dependent on crack width and spall dimensions and depth.

The defects and condition state definitions are based on the AASHTO Manual for Bridge Element Inspection.

Appendix A defines the Condition States for each individual defect. The defects are expounded on and critical areas are discussed to aid the inspector in determining the severity of a defect. The WisDOT Bridge Inspection Field Manual tabulates the element defects listed above and bases the Condition States on the progression of severity for each defect. The Condition States are comprised of general descriptions and uniquely colored to follow the severity the description represents.

- Condition State 1 Good Green
- Condition State 2 Fair Yellow
- Condition State 3 Poor Orange
- Condition State 4 Severe Red



Figure 2.4.4.5-1: Vertical to Bottom Chord Gusset Plate Deformed Out-of-Plane – Distortion Condition State 2.

2.4.4.6 Steel Arch (Element 141)

This element refers to all steel arches regardless of protective system. There are several components that make up an arch bridge, such as the arch ribs, spandrel bent columns and caps, cable hangers, built-up hangers, diagonal and vertical braces, and tie girders. This section concerns itself with all of the primary structural arch components.

Arches are primary load-carrying elements resisting axial compressive loads and bending moments. Though most steel arches have two main members, they are not tension members and are therefore not considered NSTM. Arch members are classified as solid ribbed, braced ribbed (trussed arch), spandrel braced or tied. The *Bridge Inspector's Reference Manual* has several photographs in Chapter 10 illustrating some of these arch styles.

Solid ribbed steel arches are fabricated into I-girders or box shapes. Braced rib arches have two curves (usually fabricated boxes) defining the arch shape, braced with truss webbing between the curves. These are usually used for longer spans or where better control of live load deflections is required. Spandrel braced arches are similar to solid ribbed arches, but have diagonal bracing between the spandrel bents above the arch. Tied arches have their ends connected with a tension tie girder as a means to removing the arch's horizontal thrust from its bearings. These tension ties are NSTMs of the arch element. The ties and arches are usually fabricated box members.

Deck arches receive deck, floor system, and traffic loads by way of steel spandrel bents. Spandrel bents consist of two or more steel columns connected at their tops by a transverse steel girder. The bent's girder usually acts as a floor beam, and its reaction loads are delivered to the bent columns. The columns bear directly on top of the arch ribs.



Figure 2.4.4.6-1: Steel Arch and Spandrel Bent Columns.

Through arches and tied arches suspend the deck, floor system, and traffic loads underneath by way of hangers. The hangers may be either cables or built-up steel tension members. On



half through arches and continuous tied arches, the bridge deck is also supported on spandrel bents near the arch bearings.

Element Level Inspection

On the inspection report form, arches are recorded in units of lineal feet. A steel arch bridge will have at least two arches. The correct method to calculate the quantity is to sum of all lengths of each panel as measured longitudinally along the travel way. This element includes all primary components in the plane of the arch including all spandrel components (columns, caps and bracing). The arch components may exhibit more than one Condition State along its length. Distress observed on vertical, diagonal or bracing members shall be reported as the length projected along the length of the arch. Where multiple condition states exist within a unit of measure only the predominant defect in severity and extent is recorded. The other defects located within the unit of measure shall be captured by the inspector under the element or appropriate defect notes. The sum of all of the reported condition states must equal the total quantity of the element. This will quantify the element's condition and help generate quantity/cost estimates for future remedial work.

The arch ribs, arch diagonals, spandrel columns, spandrel longitudinal bracing, built-up hangers, and tie girders are all evaluated under the arch element. Steel arches include both solid and braced ribbed arches. On braced rib arches, the top and bottom chords and the vertical and diagonal longitudinal bracing between them should be considered part of the arch element.

Through arches contain overhead lateral and vertical sway bracing. For through trusses *or through arches*, the upper bracing (lateral, vertical, portal, and sway) will be evaluated and coded under Assessment 9170 – Truss or . All lateral bracing below the roadway and not between the arch ribs will be evaluated under assessment 9169 Lateral Bracing. Refer to Chapter 7, Part 2 for additional information on Assessments. The upper bracing supports the arch ribs, which are compression members, preventing the ribs from moving out of plane thus making them important members. Its failure could result in the buckling of the arch rib.

Deck arches have no bracing located above the roadway. All bracing on deck arches shall be evaluated under the arch element. Similar to the bracing between arch ribs, all bracing on a deck arch can be viewed as bracing the compression members (arch ribs). Therefore all the bracing on deck arches is considered primary.

Safety Inspection

During the Element Level Inspection of arch, longitudinal bracing, column and shaft members, it is important not to forget that the entire purpose of bridge inspection is to ensure public safety. A structural inspection must also be carried out. The following will serve as a guide for the inspector of what to look for and where to look for it while examining one of these members. This will also help the inspector judge a member's ability to carry the design loads and identify current or future structural problems.

Arches: Arch ribs carry compressive loads and bending moments. Compressive forces are fairly constant throughout the arch. Bending moments will be variable and depend on the location of arch hinges. Moments are zero at the hinges. Arches may have three hinges (one at the crown and two at the bases), two hinges (at the bases), or no hinges (fixed).



Maintenance inspection of steel arches should include the following items:

- Looking for local compression overload damage in the form of local member component buckling, plate waviness or crippling.
- Looking for global buckling which will take the form of longitudinal rib misalignment.
- Checking suspect fasteners for looseness by twisting by hand or tapping the heads with a hammer.
- Checking corroded areas for excessive section loss that may be increasing member stress. Particular attention should be given to details that trap water.
- Inspection of the longitudinal bracing members of braced rib arches. These members should be inspected in a manner similar to truss members (see Section 2.4.4.4 Steel Truss (Element 120). They are designed to take compressive loads, tensile loads or both.
- Examining the rib splice plates for loose fasteners and excessive corrosion.
- Investigating the hinge pins for corrosion and excessive wear.

Spandrel Components

Spandrel components on arch bridges may carry a combination of compressive loads and bending moments (spandrel columns and caps), tensile loads (hangers or longitudinal bracing members) or compressive loads (longitudinal bracing).

Maintenance inspection of spandrel components should include the following items:

- Looking for local compression overload damage in the form of local member component buckling, plate waviness or crippling.
- Looking for global buckling which will take the form of a bow or sweep in the member.
- Examining the member ends for cracks and loose fasteners.
- Checking suspect fasteners for looseness by twisting by hand or tapping the heads with a hammer.
- Checking corroded areas for excessive section loss that may be increasing member stress. Particular attention should be given to details that trap water.

Safety Inspection - Fatigue

Tension members on arches and shafts include hangers, arch braces, and spandrel braces. Fatigue cracks usually show up as rust stains or rusty breaks in the paint, propagating perpendicular to the direction of stress.

Fatigue inspection of arch and spandrel components should include the following items:



- Closely inspecting all surfaces for fatigue cracks on tension members and on the hangers of through and tied arches. Fatigue cracks are most likely to form at areas of stress concentrations such as rivet holes or discontinuous welds.
- Looking for stress risers in the form of welded repairs or reinforcement plate attachments. Welded reinforcement plate attachments have one of the lowest fatigue strengths of any detail.
- Closely examining areas of heavy corrosion and section loss that can also act as notches and stress risers.
- Checking defects such as tack welds, gouges, and indiscriminately placed attachment welds. Welds made to old steel that is not very weldable have a tendency to cause cracking in the base metal. These defects should be ground smooth or closely monitored to spot crack development.

Element Defects

Refer to Appendix A for Defect descriptions. The defects listed are unique to the element and element material (i.e. concrete, steel, timber, etc.).

- Corrosion (1000)
- Cracking (1010)
- Connection (1020)
- Distortion (1900)

All defects on gusset plates connecting bracing below or above the deck on steel arches would be recorded under the assessment notes for 9169 Lateral Bracing if below or 9170 Truss or Tied/Arch Portal Bracing if above. Defects found on gusset plates within the plane of the arch would be captured under the appropriate defect under the Steel Gusset Plate element 162.

Condition State Commentary

Elements exhibiting damage should report the damage in the note of the report under the defect associated with the damage. For instance traffic impact damage is observed on the arch rib of a through arch near the roadway. This damage would be recorded in the Steel Arch element under defect Distortion 1900. The inspector would note in the defect notes that the distortion was caused by traffic impact.

The inspector is responsible to carry all necessary equipment to make accurate measurements if necessary.

The defects and condition state definitions are based on the AASHTO Manual for Bridge Element Inspection.

Appendix A defines the Condition States for each individual defect. The defects are expounded on and critical areas are discussed to aid the inspector in determining the

severity of a defect. The WisDOT Bridge Inspection Field Manual tabulates the element defects listed above and bases the Condition States on the progression of severity for each defect. The Condition States are comprised of general descriptions and uniquely colored to follow the severity the description represents.

- Condition State 1 Good Green
- Condition State 2 Fair Yellow
- Condition State 3 Poor Orange
- Condition State 4 Severe Red



Figure 2.4.4.6-2: Pack Rust at Riveted Steel Arch Flange Plates – Connection Condition State 3.

2.4.4.7 Steel Pin or Pin and Hanger Assembly (Element 161)

These elements are primary load-carrying members. On trusses and two-girder system bridges, pin and hanger assemblies are NSTMs. The pins for this element refer to those used to connect truss members or girders, and not the pins sometimes used for bearings. Individual bridge pin elements are located at member end connections of many trusses or on multi-span girders where the girder frames into a transverse girder. Pin and hanger assemblies, consisting of two pins and two hangers, are found on multi-span girder bridges where it is necessary to locate an expansion hinge away from a pier. The assemblies are placed at the tip of a girder's cantilever span and are used to suspend an adjacent span. Cantilevered trusses also use pin and hanger assemblies, but for Element Level Inspection purposes, the pins are treated as individual pin elements, and the hanger is considered a truss vertical member. Truss hangers should therefore be inspected according to Section 2.4.4.1, as an axial or bending steel member **Error! Reference source not found.**

Pins are intended to be frictionless connections that allow for member rotation, but are not designed to carry any torsion. They are fabricated in a variety of sizes. The smallest are solid and use cotters to prevent the pin from walking out of the connection under vibratory loads. Medium diameter pins are also solid, but their ends are threaded so that nuts can be used to prevent walkout. Sometimes, holes are drilled through the center axis of medium sized pins. The largest pins have holes drilled through their center axis, through which passes a threaded rod. The rods also pass through pin end cap plates. Nuts are threaded onto the rod to retain the cap plates and therefore the pin. On trusses, pins are normally employed to connect the ends of eyebars or loop rods, although large pins can connect the ends of modern built-up members. On girders, single pins pass through web plates framed into transverse cross girders to form a non-expansion hinge.

Hangers are designed to act as links and are consequently intended to be tension only members. At least two are used per connection, one on each side of the girder web. Hangers may be shaped as simple flat plates, or as eyebars.



Figure 2.4.4.7-1: Pin and Hanger Assembly.**Figure 2.4.4.7-2:** Single Pin and Plate Assembly.

Element Level Inspection

These elements encompass all steel pins and pin and hanger assemblies regardless of protective system.

On the inspection report form, pin/pin and hanger assemblies are recorded in units of “each”. This is because complete pin and hanger removal/replacement is normally required for severe deterioration. For each pin or assembly, it is the inspector’s task to assign the most appropriate defect Condition State to the entire element, which includes the hangers (if present). This will quantify the element’s condition and help generate quantity/cost estimates for future remedial work. If multiple defects are found within the same unit of measure, the inspector shall record the predominant defect on the inspection report and describe other defects within the notes under the element. The predominant defect is determined first by Condition State. If Condition States are equal, the hierarchy then falls to the lowest associated defect number.

Safety Inspection

During the Element Level Inspection of pin/pin and hanger assemblies, a structural inspection must also be carried out. A structural failure of either a pin or hanger on a NSTM bridge would likely mean a total collapse. The following will serve as a guide for the inspector of what to look for and where to look for it while examining one of these members. This will also help the inspector judge a member’s ability to carry the design loads and identify current or future structural problems.



Pins: Safety inspection of single pins or those in pin and hanger assemblies should include the following items:

- Examining all pins for signs of the desired member rotation about the pin, such as powdery orange or red rust (fretting rust) near surfaces that rub, cracked paint between the pin and member or physical movement as traffic crosses the bridge.
- Measuring the amount of pin wear on truss, arch, or girder hanger expansion hinge assemblies. Since access may be difficult due to closely-spaced members or cap plates, creative measurements must be made. Two measurements must be taken at each pin to obtain adequate information of pin or member wear. The inspector should measure the distance from the centerline of the pin to the end of the hanger and measure from the center of the pin to the inside flange surface of the girder through which the pin passes. These readings will give measurements for wear at the pin/hanger interface and pin/web interface, respectively.
- Measuring the amount of pin wear on non-expansion hinges. The inspector should measure from the center of the pin to the inside surface of the girder's top and bottom flanges. These readings will give measurements for wear at the bottom of pin/web interface and top of pin/web interface, respectively.
- Making the above-mentioned measurements from the centerline of the threaded rod on pins using cap plates.
- Comparing the above-mentioned measurements to the distances shown on the original design drawings, accounting for the pin hole tolerance (usually 1/32 inch). Wear of 1/8 inch or greater should be brought to the attention of the Program Manager. If the original design drawings are not available, the inspector should record the measurement for comparison to measurements taken on future inspections. If possible, a wire or stiff steel rule should be used to probe between the plies of plates to measure the distance from the pin surface to the surfaces mentioned above.
- Checking for ratcheting. On new structures, rotations are accommodated by the girder web sliding on the pin surface. Fretting corrosion between the web hole and pin surface will advance, eventually "locking up" the web/pin movement. After this occurs, rotations take place by the hanger sliding on the pin surface. This is known as ratcheting, and is evidenced by a broken paint film, wear marks, and corrosion between the pin nut and hanger plate.
- Looking for pack rust in between the girder web and hanger. Pins connecting plate hangers or tightly packed eyebars are difficult to access. As a result, these pins often do not receive proper cleaning or painting during maintenance operations, and excessive corrosion rather than excessive wear may be the consequence. Excessive corrosion may lock up the joint, introducing unintended bending stresses into the pin and hanger or superstructure member.
- Tapping the pin or threaded rod nut with a hammer to check for excessive looseness. If the pins are excessively loose, notify the Program Manager immediately. A bridge inspector should never unscrew a pin nut or remove a cap plate to get a better look at

the pin. Disassembly is not part of a Routine inspection. Doing so could be catastrophic if pack rust between the girder web and hanger has placed the assembly on the verge of failure. Disassembly is only undertaken as part of an In-Depth Inspection program and only after proper auxiliary joint support is in place.

- Checking the cap plates for flatness.
- Checking to make sure adjacent girder flanges and webs are in alignment.



Figure 2.4.4.7-3: Pin Shear Failure.

Hangers: Safety inspection of hangers in pin and hanger assemblies should include the following items:

- Measuring the distance between the hanger and girder web at several locations. Variation of 1/8 inch or more could mean hanger twist or lateral movement.
- Looking for fretting corrosion between the hanger and girder web, which will be evident by a dusty-looking reddish rust around the plates' interface. Fretting corrosion is caused by two tightly fitting plates rubbing against each other.

Safety Inspection – Hanger Cracks

Hanger plates are very susceptible to damage when corrosion “freezes” the pins and does not allow for free rotation. When this occurs, the assembly ceases to behave as a hinge, and begins to carry bending moments. These bending moments introduce tensile stresses into the hangers in addition to the tensile stress for which the hangers were designed. Out-of-plane bending stresses may also be generated from girder misalignment or pack rust. As a result, overstress cracks may develop in the hanger plate.

Inspection of hangers in pin and hanger assemblies should include the following items:



- Careful checking all edges and surfaces of all hangers, especially the ends beyond the pin centerlines, and the forged areas of any eyebars. Forged areas will usually be near the eyebar head and body junction.
- Checking both sides of the hanger for fatigue cracks, if possible. A flashlight and inspection mirror may help.
- Using nondestructive evaluation methods (dye penetrant, magnetic particle, ultrasonic) to look for cracks. Nondestructive evaluation should be performed as part of an In-Depth Inspection.
- Immediately reporting any cracks to the Inspection Program Manager. The nature of pin and hanger assemblies is that a failure of one may cause a domino effect failure on multi-girder bridges.

Element Defects

Refer to Appendix A for Defect descriptions. The defects listed are unique to the element and element material (i.e. concrete, steel, timber, etc.).

- Corrosion (1000)
- Cracking (1010)
- Connection (1020)
- Distortion (1900)

Condition State Commentary

Elements exhibiting damage should report the damage in the note of the report under the defect associated with the damage.

The inspector is responsible to carry all necessary equipment to make accurate measurements if necessary.

The defects and condition state definitions are based on the AASHTO Manual for Bridge Element Inspection.

Appendix A defines the Condition States for each individual defect. The defects are expounded on and critical areas are discussed to aid the inspector in determining the severity of a defect. The WisDOT Bridge Inspection Field Manual tabulates the element defects listed above and bases the Condition States on the progression of severity for each defect. The Condition States are comprised of general descriptions and uniquely colored to follow the severity the description represents.

- Condition State 1 Good Green
- Condition State 2 Fair Yellow
- Condition State 3 Poor Orange

- Condition State 4 Severe Red



Figure 2.4.4.7-4: Steel Girders, Pin and Plate – Condition State 1.



Figure 2.4.4.7-5: Girder, Pin, and Hanger – Corrosion Condition State 2.



Figure 2.4.4.7-6: Pin and Hanger – Corrosion Condition State 4.

2.4.4.8 NSTM Steel Superstructure Inspection

Members are classified as being either nonredundant steel tension member (NSTM) or non-NSTM. Per CFR 23 Subpart C 650.305, a nonredundant steel tension member is, “A primary steel member fully or partially in tension, and without load path redundancy, system redundancy or internal redundancy, whose failure may cause a portion of or the entire bridge to collapse.” Superstructures that have one or two primary load-carrying members spanning between supports that are in tension or have a tension component are not load path redundant. This means that failure of one of these primary members will likely cause a collapse of the entire structure. Superstructures that have three or more primary load-carrying members spanning between supports are non-NSTM. These members are load path redundant, which means that if one of the primary members fails, the loads it carries can be redistributed to the remaining primary members, thereby preventing a total collapse.



Figure 2.4.4.8-1: NSTM Two-Girder Bridge.



Figure 2.4.4.8-2: NSTM Through Girder Bridge.



NSTMs require special attention during an inspection. There must not be any other member or system of members that will serve the functions of the member in question should it fail. Fatigue failures are the main cause of concern of steel NSTMs since fatigue failures can be brittle and give no warning as to imminent collapse.

The detailed procedures for carrying out a inspection are beyond the scope of this Manual. However, it is highly recommended for the inspector to become familiar with the FHWA Memorandum *Inspection of Nonredundant Steel Tension Members*, as this reference provides complete information on this topic. It contains information related to NSTM inspection organization, definitions of NSTM bridges, inspection procedures, reports, and recommendations. The following text describes the minimum NSTM Inspection requirement for the State of Wisconsin.

Inspection Preparation

The inspection team should develop the Inspection Procedures, Plan and NSTM Plan. Inspection Preparation is an important part of the NSTM Bridge Inspection. Important steps that will help in accomplishing a successful inspection are; Planning, Scheduling, Equipment, Personnel Requirements, and Field Inspection Procedures.

Historical Plan and Review

It is critical to gather all of the historical information that is available. Suggested information that may be available:

- Original design plans
- “As-built” plans
- Original shop drawings
- Construction history
- Maintenance history
- Rehabilitation history
- Bridge inspection reports and photographs

This information should be reviewed by the Inspection Program Manager and Inspection Team Leader prior to performing the NSTM Inspection, in order to determine the NSTM. It is strongly recommended that original plans and documents remain in the office of the maintaining agency and that only copies are taken to the field.

Identification of NSTMs

NSTMs shall be identified by the Program Manager working with the Inspection Team Leader. This identification shall be shown on the plans or a sketch of the bridge.



NSTMs, member components, and all other tension members must be identified on the Inspection form or an attached plan.

To qualify as a NSTM, the member or components of the member must be in tension and there must NOT be any other member or system of members that will serve the functions of the member in question should it fail. The alternate systems or members represent redundancy.

Tension components of a bridge member consist of components of tension members and those portions of a flexural member that are subject to tension stress. Any attachment having a length in the direction of the tension stress greater than 4 inches, and welded to the tension area of a NSTM shall be considered part of the tension component and, therefore, shall be considered "NSTM".

NSTMs have all or part of their cross-section in tension. Most cracks in steel members occur in the tension zones, generally at a flaw or defect in the base material. Frequently, the crack is a result of fatigue occurring near a weld, a material flaw, and/or changes in member cross-section. See Appendix for a review of typical fatigue prone details.

After the crack occurs, failure of the member could be sudden and lead to collapse of the bridge. For this reason, steel bridges with the following structural characteristics or components should be reviewed for a NSTM Inspection.

- Two-truss through bridges
- Low two-truss bridges (pony trusses)
- Deck two-truss bridges
- Thru-girder bridges
- Two-girder bridges
- Tied arch bridges
- Movable bridges
- Steel pier caps and cross-girders
- Pin and hanger system on two- or three-girder systems

See Appendix for examples of NSTM bridges, components, bending definitions, typical crack locations, and typical pin and hanger parts.

Inspection Plan

The inspection plan is the final step in preparation for the field inspection. From the information gathered, a plan needs to be organized for the field inspection. A pre-inspection visit to the site may be required to finalize the inspection plan.



Visual inspection is intended to be the primary examination method of Wisconsin's NSTM Inspection policy. This policy requires that each NSTM member or member component be inspected "hands-on", a maximum distance of one arm's length for the entire length of the member and/or member component.

An inspection plan may include some or all of the following and must be prepared prior to the field inspection:

- A brief historical fact statement
- Essential plans that would help with field inspection
- Identification of NSTMs on inspection form or attached plan
- Access equipment and personnel needed to perform the field inspection
- Inspection tools and safety equipment needed to perform the field inspection
- Traffic control requirements
- Estimate of inspection time
- Coordination with and notification of owner and other agencies

To meet the minimum requirements of this policy, all of the required information shall be noted in appropriate locations of the NSTM bridge inspection report form. On larger or more complex structures, it may be necessary to create chapters for each of the required areas of the inspection plan, which can be attached to the NSTM bridge inspection report form.

Field Inspection Procedures, Reports, and Condition Ratings

Field inspection procedures are the implementation of an inspection plan. Good preparation will increase the quality of the field inspection and ensure that all needed tools, safety devices, and operational procedures are available to effectively and efficiently complete the task. It is critical that the Inspection Team Leader guide the field inspection process to assure that each inspection is given the desired level of quality and assures public safety.

Historical Review

The construction history, along with any rehabilitation and maintenance history should be reviewed at the bridge site prior to performing an inspection. This will be helpful in possibly defining deficiencies that may be found during the inspection. It also is advantageous to know the age of possible deficiencies to determine their criticality when making final recommendations.

NSTM Plan Review

Bridge orientation should be evaluated to determine the location of NSTMs. Location of panel points in relation to orientation of the bridge should be determined.



The NSTMs that have been identified on the inspection plan should be reviewed prior to performing the inspection. The inspector shall analyze the types of deficiencies that may be expected from the bridge details, risk factors, and potential issues in formulating their Inspection procedures and plan. Also, the inspector shall determine if any of the repairs or rehabilitation since original construction may have influenced the deterioration of a particular member or connection. Possible locations for potential cracking should be identified and highlighted on the inspection plan.

Traffic Control

Traffic control requirements should be reviewed prior to performing an inspection to assure safety of the inspection team and the traveling public. The Inspection Team should review the traffic control requirements with persons performing the traffic control, if they are not part of the Inspection Team. The traffic control requirements shall be documented on the NSTM bridge inspection report form. Any unsafe traffic control conditions should be corrected before performing an inspection.

Access Equipment and Procedures

Access equipment must be evaluated to determine if it can provide the required visual “hands-on” inspection of all NSTMs.

Typical methods of access available include but are not limited to:

- Deck-parked under-bridge inspection units (Snooper, Reach-All, etc.)
- Ground-parked aerial lifts (manlift, etc.)
- Scaffolding and staging
- Boats
- Ladders
- Climbing/Rope access

Access equipment, safety features, and procedures need to be evaluated prior to inspection. The safety sheet provided with the equipment, including emergency evacuation procedures, should be reviewed.

The Wisconsin Department of Transportation (WisDOT) can offer specialized equipment and services that may be required on certain bridges for access. One of the most useful pieces of equipment available is an under bridge inspection unit. Only trained WisDOT personnel are authorized to operate these units.

Personal Safety

All personal safety equipment needed for an inspection shall be identified and checked for condition. Such equipment may include, but is not limited to, high visibility clothing, body



harnesses, hard hats, safety shoes, eye protection, ear protection, respiratory protection, and protection from hazardous paint or other materials.

Safety of the inspector is essential in providing a quality NSTM inspection. Providing for all the proposed safety requirements is paramount to maintain the confidence of the inspector and to ensure a quality NSTM inspection.

Inspection Tools

A review of the tools listed on the inspection plan should be done, along with a review of the conditions on the bridge, to determine what tools may be required to perform a thorough visual, “hands-on” inspection.

There may be a considerable amount of debris or corrosion in the areas that require inspection. It is critical that all debris and loose corrosion be removed to perform the inspection.

Tools that may be helpful during a NSTM Inspection include:

- Hand-held scraper
- Chipping hammer
- Wire brush
- Drafting brush
- Pocket knife
- Rulers
- Flashlight (or halogen light if power is available)
- Ten-power magnifying glass or crack comparator
- Camera
- Calipers (or D-meter for thickness measurement)

For difficult areas, small power grinders, wire brushes or end grinders may be helpful.

Field Inspection

All NSTMs components identified on the inspection plan must be inspected “hands-on”. The members and/or components shall be cleaned so that all extraneous material is removed to provide for a thorough evaluation.

The condition of each member and/or component must be determined, including any deficiencies such as section loss, cracks, unspecified welds, field welds, tack welds, sharp



bends, kinks or other unspecified damage. For information on how to record the condition of each NSTM, see Part 1.

Specialized NDE that may be required for certain details, or to further analyze defects. The following nondestructive testing services are readily available:

- Ultrasound for analysis of pins, welds and cracks
- Liquid (dye) penetrant for surface flaw analysis
- Magnetic particle for surface or slightly subsurface flaw analysis
- Ultrasound thickness gauge for section loss analysis
- Other NDE services may be available as well.

Deficiencies that require emergency repairs or action shall be reported immediately to the Inspection Program Manager and bridge owner. If the Inspection Team Leader has doubts about the load-carrying capacity of a bridge when such deficiencies are found, they shall take action to close the bridge and make immediate contact with the Inspection Program Manager. Team Leaders do have the authority to close a bridge when, in their judgment, it is unsafe for use. Local law enforcement or state patrol may be called to assist in bridge closure. Only the Inspection Program Manager shall have the authority to reopen a bridge.

2.4.5 Timber Structures

Timber is probably the earliest material ever used to construct a bridge superstructure. The earliest timber superstructure form was likely a tree felled across a stream or ravine. Modern timber can be configured in many different ways, including:

1. **Slabs:** Timber slab bridges are constructed using either glue-laminated or nail-laminated sawn lumber placed longitudinally between supports. The slab acts as a single wide beam spanning from substructure unit to substructure unit. There are no individual beams with this type of bridge, so the slab also acts as the deck. Slabs are used for simple spans of about 35 feet or less and for continuous spans of slightly greater lengths. Glue-laminated slab depths range from 6-3/4 inches to 14-1/4 inches thick, using individual strips of dimensional lumber 3/4 to 2 inches thick to form 42-inch to 54-inch wide panels. Nail-laminated slab depths range from 8 inches to 16 inches deep, using 2-inch to 4-inch dimensional lumber. For maximum strength and stiffness, the lumber width is oriented vertically in the completed structure. Timber slabs may have transverse distributor/spreader beams (Element 8166) attached to their undersides as a method to distribute live loads across the entire bridge width. Steel transverse post-tensioning rods (Element 8165) may also be used for this purpose, as well as to keep the planks in alignment on glue-laminated slabs. See Part 2 Chapter 3 Decks and Slabs for element level inspection of timber slabs.
2. **Solid sawn multi-beams:** Solid sawn multi-beam bridges are constructed using three or more beams as the primary members. Span lengths are limited by the longest available length of solid lumber, so they are usually used for bridge spans from 15 to 30 feet. Typical beam dimensions are 4 to 8 inches wide and 12 to 18 inches deep. Beam spacing is usually on the order of 2 feet on center. Solid wood blocking or bridging is normally placed between the beams to keep the beam in proper alignment. Due to the limited availability of large timbers of this size and the ready availability of high quality glue-laminated beams, solid sawn multi-beam bridges are rarely built nowadays.



Figure 2.4.5-1: Solid Sawn Multi-Beam Bridge.



Figure 2.4.5-2: Solid Sawn Multi-Beam Bridge.

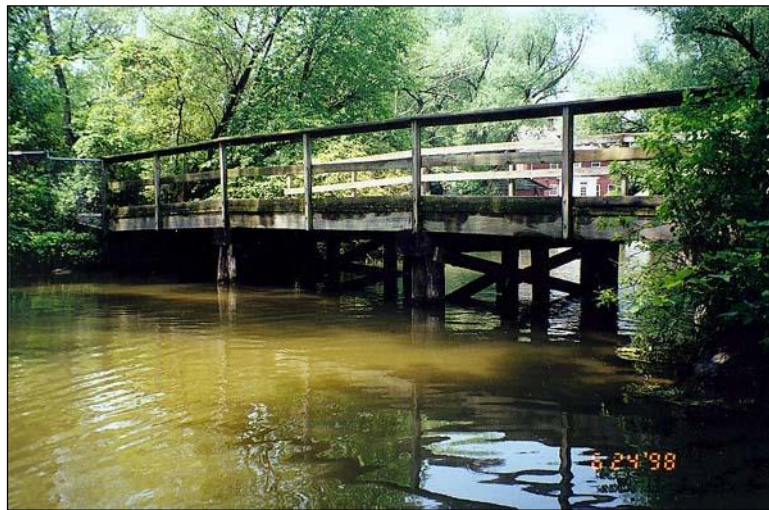

Figure 2.4.5-3: Solid Sawn Multi-beam Bridge.

- 3. Glue-laminated multi-beams:** Glue-laminated multi-beam bridges are similar to sawn multi-beam bridges, with the exception that the beams are pre-manufactured members. This is performed by bonding several strips of wood together with a waterproof structural adhesive to form a built-up beam. By using $\frac{3}{4}$ -inch to 2-inch thick strips of wood for the laminations, natural wood defects may be placed in a non-critical location or may be eliminated completely from the final product. The result is a fairly uniform beam with strength properties greater than solid wood of similar dimensions. Standard 3-inch to 14 $\frac{1}{4}$ - inch wide beams are common, and depths are limited only by transportation and pressure treating considerations. Clear spans up to 150 feet have been attained, though spans less than 80 feet are more common.



4. **Trusses/covered bridges:** Truss bridges are structures with two parallel trusses as the main load-carrying members. Covered bridges are truss bridges with a wood covering to prevent decay of the superstructure. Spans up to 250 feet are attainable. The deck is typically placed between the trusses (through truss when there is overhead lateral bracing or a pony truss when there is no overhead lateral bracing), although it may sometimes be placed on top of the trusses (deck truss). Modern connections are made with steel bolts and gusset plates. Older trusses use wooden peg connections. Truss bridges normally have wood floor systems using floor beams, and usually stringers. To keep the two trusses in line longitudinally, secondary lateral bracing members diagonally connect the bottom chords, and for deck and through trusses, the top chords as well. Lateral bracing may be made of wood, wrought iron or steel. Sway bracing keeps the two trusses in line laterally. On deck and through trusses, sway bracing transversely frames between the truss verticals. On pony trusses, sway bracing is usually placed as a transverse diagonal on the outsides of the trusses. It connects the top chord to transverse “outrigger” floor beam extensions and functions to prevent buckling of the top chord. Sway bracing is normally made out of wood.

5. **Arches:** Modern wood arch bridges are constructed of curved glue-laminated main members. Wood arches use two hinges for spans up to about 80 feet. Spans up to about 300 feet are feasible, and these arches use three hinges. Wood arches are most commonly used as pedestrian bridges, although they have been built for highway use.

2.4.5.1 Timber Open Girder (Element 111)

Timber Stringer (Element 117)

Floor Beam (Element 156), Timber Spreader Beam (Element 8166)

These elements are the primary bending elements of sawn or glulam multi-beam bridges. Timber beams of multi-beam bridges may be recorded as either an open girder or stringer, depending upon the inspector’s interpretation of these terms. Floor beams, most commonly found on wood truss or arch bridges, span transversely between these main load-carrying members. Transverse distributor beams, commonly located under timber slabs, should be considered as timber spreader beams. In the case where a deck is supported by a floor system, timbers that tie into the floor beam shall be recorded as stringers, while timbers that floor beams tie into shall be recorded as girders.



Figure 2.4.5.1-1: Multiple Timber Beams.

Element Level Inspection

On the inspection report form, timber girders/beams and floor beams are recorded in units of lineal feet. The correct method for calculating the beam length is the sum of all of the lengths of each beam section and multiplying by the span length for each span. Where multiple condition states exist within a unit of measure only the predominant defect in severity and extent is recorded. The other defects located within the unit of measure shall be captured by the inspector under the element or appropriate defect notes. The sum of all of the reported condition states must equal the total quantity of the element. This will quantify the element's condition and help generate quantity/cost estimates for future remedial work.

Element Level Inspection of timber girders, stringers, and floor beams should include the following items:

- Checking for member crushing at the abutments and piers. These are the most suspect areas because they tend to collect and retain the most moisture and debris, creating ideal environments for fungal growth and insect attack.
- Looking for shear related damage at and near the supports. Overloads result in high shear stresses that cause horizontal splits to form along the length of the beam, approximately mid-height. Splits will allow fungi and insects access to the untreated interior of a beam.
- Examining the high flexural regions of the beam for signs of overload damage such as crushing near the top surface and transverse cracking near the bottom surface.
- Examining floor beam connections to trusses or arches for splits or checks. This type of damage can seriously weaken the connection.
- Looking for decay at the top of the beam where deck planks are attached. This area is ideal for trapping and retaining moisture, resulting in beam decay.



- Examining the entire member for signs of decay. Signs include discolored wood with a soft, rotted texture. Look also for fruiting bodies and depressed areas of the wood surface.
- Looking for any delaminations of individual wood strips in glulam beams. Because debonding that extends through the beam width changes the original deep, stiff member into two smaller flexible members, this type of deterioration can be especially serious.
- Examining the entire member for signs of insect attack. Signs include piles of sawdust, small holes in the wood surface, insects themselves, and a hollow sound when the beam is tapped with a hammer.
- Look for fire damage, especially near the abutments where fires can be built close to the beams.
- Checking fasteners (nails, bolts, lag screws, deck clips) for corrosion or slipping. Check suspect fasteners for looseness by striking with a hammer. The location of any missing fasteners should be noted.
- Sighting along the length of the beam under traffic loads to look for excessive vertical or lateral deflections. Excessive deflections indicate that the member cannot carry its original design load or that other bridge members are damaged and additional load has shifted to the member in question. The measured or estimated amount of deflection should be recorded.
- Hammer tapping random and suspect areas to evaluate the wood’s soundness.
- Performing probe tests in areas suspected to be experiencing decay. See Section 2.3.4.1, Timber Slab (Element 54) for a description of this procedure.
- Drilling or boring suspect planks to estimate the extent of decay.
- Looking for collision damage and reporting this condition under the appropriate Condition State. Signs of impact damage include scrapes on member undersides, chips, cracks, and possibly a permanently displaced or broken member.

Element Defects

Refer to Appendix A for Defect descriptions. The defects listed are unique to the element and element material (i.e. concrete, steel, timber, etc.).

- Connection (1020)
- Decay/Section Loss (1140)
- Check/Shakes/Cracks/Splits/Delamination (1150)
- Abrasion/Wear (1180)



- Distortion (1900)

Condition State Commentary

Elements exhibiting damage should report the damage in the note of the report under the defect associated with the damage. For instance traffic impact damage is observed on the underside of a timber girder. This damage would be recorded in the Timber girder element under defect Decay/Section Loss. The inspector would note in the defect notes that the section loss was caused by traffic impact.

The inspector is responsible to carry all necessary equipment to make accurate measurements if necessary.

The defects and condition state definitions are based on the AASHTO Manual for Bridge Element Inspection.

Appendix A defines the Condition States for each individual defect. The defects are expounded on and critical areas are discussed to aid the inspector in determining the severity of a defect. The WisDOT Bridge Inspection Field Manual tabulates the element defects listed above and bases the Condition States on the progression of severity for each defect. The Condition States are comprised of general descriptions and uniquely colored to follow the severity the description represents.

- Condition State 1 Good Green
- Condition State 2 Fair Yellow
- Condition State 3 Poor Orange
- Condition State 4 Severe Red



Figure 2.4.5.1-2: Timber Beams – Decay/Section Loss Condition State 1.



Figure 2.4.5.1-3: Timber Beams – Checks/Shakes/Cracks/Splits/Delaminations Condition State 1.



Figure 2.4.5.1-4: Timber Beam – Decay/Section Loss Condition State 4.



2.4.5.2 Timber Truss (Element 135)

These elements are primary load-carrying members. Truss members are theoretically loaded in either pure tension or compression. Truss components may be constructed of either sawn lumber or glulam members. Covered bridges are trusses with covers to protect the wood from moisture due to rain, sleet, and snow. Deck dead and live loads are delivered to both trusses and arches by way of floor beams spanning transversely between these main load-carrying members.

Element Level Inspection

This element encompasses all timber truss elements. This includes all tension and compression primary members throughout the truss. Observed distress in truss vertical or diagonal members shall be reported as the length projected along the length of the truss.

On the inspection report form, trusses are recorded in units of lineal feet. A timber truss bridge will have at least two trusses. The correct method to calculate the quantity is to sum of all lengths of each panel as measured longitudinally along the travel way. This element includes all primary components in plane with the truss including, the bottom chord, top chord, verticals and diagonals. For through trusses *or through arches*, the upper bracing (lateral, vertical, portal, and sway) will be evaluated and coded under Assessment 9170 – Truss or Arch Overhead Bracing System. The truss components may exhibit more than one Condition State along its length. Distress observed on vertical, diagonal or bracing members shall be reported as the length projected along the length of the truss. Where multiple condition states exist within a unit of measure only the predominant defect in severity and extent is recorded. The other defects located within the unit of measure shall be captured by the inspector under the element or appropriate defect notes. The sum of all of the reported condition states must equal the total quantity of the element. This will quantify the element's condition and help generate quantity/cost estimates for future remedial work.

Element Level Inspection of timber trusses should include the following items:

- Checking the truss bottom chord members for crushing at the abutments. These are the most suspect areas because they tend to collect and retain the most moisture and debris, creating ideal environments for fungal growth and insect attack.
- Examining the entire element for signs of decay. Signs include discolored wood with a soft, rotted texture. Look also for fruiting bodies and depressed areas of the wood surface.
- Looking for any delaminations of individual wood strips in glulam members. Debonding occurring in the vicinity of connectors can be serious if the member is carrying tensile loads.
- Examining the entire member for signs of insect attack. Signs include piles of sawdust, small holes in the wood surface, insects themselves, and a hollow sound when the member is tapped with a hammer.
- Look for fire damage, especially near the abutments and arch bearings where fires can be built close to the primary load-carrying members.



- Checking fasteners (nails, bolts, lag screws, deck clips) for corrosion or slipping. Check also for fastener looseness by striking with a hammer. The location of any missing fasteners should be noted.
- Sighting along the length of a truss under traffic loads to look for excessive vertical or lateral deflections. Excessive deflections indicate that the member cannot carry its original design load or that other bridge members are damaged and additional load has shifted to the member in question. The measured or estimated amount of deflection should be recorded.
- Performing probe tests in areas suspected to be experiencing decay. See Section 2.3.5.1, Timber Slab (Element 54) for a description of this procedure.
- Drilling or boring suspect members to estimate the extent of decay.
- Looking for collision damage and reporting this condition under the appropriate Condition State. Signs of impact damage include scrapes on member undersides, chips, cracks, and possibly a permanently displaced or broken member.

Element Defects

Refer to Appendix A for Defect descriptions. The defects listed are unique to the element and element material (i.e. concrete, steel, timber, etc.).

- Connection (1020)
- Decay/Section Loss (1140)
- Check/Shakes/Cracks/Splits/Delamination (1150)
- Abrasion/Wear (1180)
- Distortion (1900)

Condition State Commentary

Elements exhibiting damage should report the damage in the note of the report under the defect associated with the damage. For instance traffic impact damage is observed on the underside of a timber girder. This damage would be recorded in the Timber girder element under defect Decay/Section Loss. The inspector would note in the defect notes that the section loss was caused by traffic impact.

The inspector is responsible to carry all necessary equipment to make accurate measurements if necessary.

The defects and condition state definitions are based on the AASHTO Manual for Bridge Element Inspection.

Appendix A defines the Condition States for each individual defect. The defects are expounded on and critical areas are discussed to aid the inspector in determining the severity of a defect. The WisDOT Bridge Inspection Field Manual tabulates the element



defects listed above and bases the Condition States on the progression of severity for each defect. The Condition States are comprised of general descriptions and uniquely colored to follow the severity the description represents.

- Condition State 1 Good Green
- Condition State 2 Fair Yellow
- Condition State 3 Poor Orange
- Condition State 4 Severe Red



2.4.5.3 Timber Arch (Element 146)

These elements are primary load-carrying members. Arches are loaded in combined compression and bending. Arch components may be constructed of either sawn lumber or glulam members. There are several components that make up an arch bridge, such as the arch ribs, spandrel bent columns and caps, cable hangers, built-up hangers, diagonal and vertical braces, and tie girders. This section concerns itself with all of the primary structural arch components.

Element Level Inspection

On the inspection report form, arches are recorded in units of lineal feet. A timber arch bridge will have at least two arches. The correct method to calculate the quantity is to sum of all lengths of each panel as measured longitudinally along the travel way. This element includes all primary components in the plane of the arch including all spandrel components (columns, caps and bracing). The arch components may exhibit more than one Condition State along its length. Distress observed on vertical, diagonal or bracing members shall be reported as the length projected along the length of the arch. Where multiple condition states exist within a unit of measure only the predominant defect in severity and extent is recorded. The other defects located within the unit of measure shall be captured by the inspector under the element or appropriate defect notes. The sum of all of the reported condition states must equal the total quantity of the element. This will quantify the element's condition and help generate quantity/cost estimates for future remedial work.

The above elements include the arch ribs, arch diagonals, spandrel columns, spandrel longitudinal bracing, built-up hangers, and tie girders. Steel arches include both solid and braced ribbed arches. On braced rib arches, the top and bottom chords and the vertical and diagonal longitudinal bracing between them should be considered part of the arch element.

Through arches contain overhead lateral and vertical sway bracing. All lateral and vertical bracing above the roadway on through arches shall be evaluated under the Assessment 9170 – Truss or Arch Overhead Bracing System. All lateral bracing below the roadway and not between the arch ribs will be evaluated under assessment 9169 Lateral Bracing. Refer to Chapter 7, Part 2 for additional information on Assessments. The upper bracing supports the arch ribs, which are compression members, preventing the ribs from moving out of plane thus making them important members. Its failure could result in the buckling of the arch rib.

Deck arches have no bracing located above the roadway. All bracing on deck arches shall be evaluated under the arch element. Similar to the bracing between arch ribs, all bracing on a deck arch can be viewed as bracing the compression members (arch ribs). Therefore all the bracing on deck arches is considered primary.

Element Level Inspection of timber arch ribs should include the following items:

- Checking the arch members for crushing at the abutments. These are the most suspect areas because they tend to collect and retain the most moisture and debris, creating ideal environments for fungal growth and insect attack.
- Examining the entire element for signs of decay. Signs include discolored wood with a soft, rotted texture. Look also for fruiting bodies and depressed areas of the wood surface.



- Looking for any delaminations of individual wood strips in glulam members. Debonding occurring in the vicinity of connectors can be serious if the member is carrying tensile loads.
- Examining the entire member for signs of insect attack. Signs include piles of sawdust, small holes in the wood surface, insects themselves, and a hollow sound when the member is tapped with a hammer.
- Look for fire damage, especially near the abutments and arch bearings where fires can be built close to the primary load-carrying members.
- Checking fasteners (nails, bolts, lag screws, deck clips) for corrosion or slipping. Check also for fastener looseness by striking with a hammer. The location of any missing fasteners should be noted.
- Sighting along the length of an arch under traffic loads to look for excessive vertical or lateral deflections. Excessive deflections indicate that the member cannot carry its original design load or that other bridge members are damaged and additional load has shifted to the member in question. The measured or estimated amount of deflection should be recorded.
- Performing probe tests in areas suspected to be experiencing decay. See Section 2.4.4.1, Timber Slab (Element 54) for a description of this procedure.
- Drilling or boring suspect members to estimate the extent of decay.
- Looking for collision damage and reporting this condition under the appropriate Condition State. Signs of impact damage include scrapes on member undersides, chips, cracks, and possibly a permanently displaced or broken member.

Spandrel Components

Timber vertical spandrel columns of open spandrel arches are primary load-carrying members that support the spandrel bent cap and load the arch ribs.

Spandrel columns are primarily compression members, but they must also resist lateral bending moments due to wind loads, eccentric loading at their tops, overloads, and differential arch deflections.

Element Level Inspection of timber spandrel columns found on arches should include the following items:

- Checking the arch/spandrel column interface for bearing failures. Bearing failures on timber members loaded parallel to the grain will “broom out”.
- Checking the mid-height of the spandrel column for flexural cracks, which are a sign of structural overloads or differential arch deflection.



- Examining the entire element for signs of decay. Signs include discolored wood with a soft, rotted texture. Look also for fruiting bodies and depressed areas of the wood surface.
- Looking for any splitting of sawn timber members. Excessively long or wide splits may be a sign of a structural overload.
- Looking for any delaminations of individual wood strips in glulam members.
- Examining the entire member for signs of insect attack. Signs include piles of sawdust, small holes in the wood surface, insects themselves, and a hollow sound when the member is tapped with a hammer.
- Looking for fire damage, especially near the arch bearings where fires can be built close to the primary load-carrying members.
- Checking fasteners (bolts, lag screws) for corrosion or slipping. Check also for fastener looseness by striking with a hammer. The location of any missing fasteners should be noted.
- Sighting along the length of the bridge under traffic loading to look for out-of-plumbness. The column should also be sighted along its length to check for bowing. Excessive deflections indicate that the member has been overstressed or that the bridge is experiencing differential settlements. The measured or estimated amount of deflection should be recorded.
- Performing probe tests in areas suspected to be experiencing decay. See Section 2.4.4.1, Timber Slab (Element 54) for a description of this procedure.
- Drilling or boring suspect members to estimate the extent of decay.

Element Defects

Refer to Appendix A for Defect descriptions. The defects listed are unique to the element and element material (i.e. concrete, steel, timber, etc.).

- Connection (1020)
- Decay/Section Loss (1140)
- Check/Shakes/Cracks/Splits/Delamination (1150)
- Abrasion/Wear (1180)
- Distortion (1900)

Condition State Commentary

Elements exhibiting damage should report the damage in the note of the report under the defect associated with the damage. For instance traffic impact damage is observed on the



arch rib of a through arch near the roadway. This damage would be recorded in the Timber Arch element under defect Decay/Section Loss (1140). The inspector would note in the defect notes that the distortion was caused by traffic impact.

The inspector is responsible to carry all necessary equipment to make accurate measurements if necessary.

The defects and condition state definitions are based on the AASHTO Manual for Bridge Element Inspection.

Appendix A defines the Condition States for each individual defect. The defects are expounded on and critical areas are discussed to aid the inspector in determining the severity of a defect. The WisDOT Bridge Inspection Field Manual tabulates the element defects listed above and bases the Condition States on the progression of severity for each defect. The Condition States are comprised of general descriptions and uniquely colored to follow the severity the description represents.

- Condition State 1 Good Green
- Condition State 2 Fair Yellow
- Condition State 3 Poor Orange
- Condition State 4 Severe Red

2.4.6 Masonry Structures

The only masonry bridge superstructure form is the arch. Masonry arches have been used for building and bridge construction since ancient times (notably a 3,400-year-old Babylonian arch), and current use of some of these structures is a testament to their durability. This fact is even more remarkable when one considers that unlike modern concrete arches, stone masonry arches are not strengthened with reinforcing steel.

2.4.6.1 Masonry Arch (Element 145)

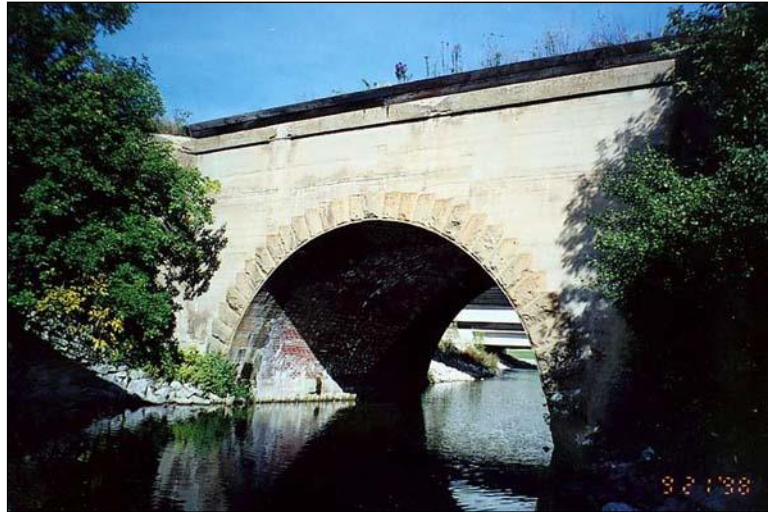

Figure 2.4.6.1-1: Masonry Arch.

In Wisconsin, most stone masonry arches span over small rivers or streams. Arches are primary elements that receive both compressive and bending moments. Since an arch carries a high degree of compressive load, there should be little, if any, net tension along its cross-section. Because of this, there should be no cracking at any of the masonry mortar joints due to bending moments.

Masonry arches are closed spandrel structures that have a single, solid barrel forming the primary load-carrying member. Fill material is always placed on top of the arch to support the roadway, and spandrel walls are used to retain this fill. Spandrel wall failure would cause the fill to spill out, resulting in roadway settlement. For Element Level Inspection purposes, spandrel walls shall be considered primary members and part of the arch element. An important point to note is that masonry arch structures will always have element 8325 “Roadway Over Structure”. This element is discussed in Part 2, Chapter 6.

Element Level Inspection

On the inspection report form, arches are recorded in units of lineal feet. The correct method to calculate the quantity is to measure along the centerline of the roadway above, not along the length of the barrel. The arch is measured from spring line to spring line. The spandrel walls that fall under the projected vertical limits of the spring line are to be assessed under the masonry arch element. Any additional length beyond the spring lines shall be assessed under the appropriate substructure element. Distress observed within the barrel of the



masonry arch shall be reported as the length projected along the travel way. Where multiple condition states exist within a unit of measure only the predominant defect in severity and extent is recorded. The other defects located within the unit of measure shall be captured by the inspector under the element or appropriate defect notes. The sum of all of the reported condition states must equal the total quantity of the element. This will quantify the element's condition and help generate quantity/cost estimates for future remedial work.

Element Level Inspection of masonry arches should include the following items:

- Examining the bearing areas for signs of crushed masonry, since the highest compressive forces experienced by an arch are found at the spring line. Missing or crushed masonry units result in a loss of arch cross-sectional area, increasing the axial stresses.
- Looking for crushed or missing masonry units and mortar. This would suggest a possible overload. Missing or crushed mortar results in a loss of arch cross-sectional area, increasing the axial stresses.
- Checking the arch and spandrel wall surfaces for bulges. This defect suggests unstable soil and the roadway above will also likely show signs of settlement. A bulge or flatness in the arch indicates that it is not functioning properly. Significant areas of bulging should be reported immediately to the Inspection Program Manager.
- Looking for cracked, broken, or deteriorated masonry units and mortar. This would suggest weathering due to freeze/thaw effects.
- Checking the entire arch for transverse mortar cracks. These are the result of excessive bending moments or arch support settlements.
- Looking for leaching along the entire arch and the spandrel walls. This indicates water is flowing through the mortar joints and leaching out the cement minerals. Long-term leaching will weaken the mortar.
- Checking areas exposed to drainage and roadway runoff. The runoff may cause scaling of the masonry units.
- Checking to make sure weep holes in the arch are functioning.
- Checking to make sure surface drains are functioning properly and are not allowing water to penetrate the fill.
- Examining previous repair areas for soundness.
- Examining connections of soil reinforcing bars. These are threaded rods that are installed through the face of the barrel wall. Fasteners should be tapped by a hammer and checked by hand to verify they are firmly installed.



Element Defects

Refer to Appendix A for Defect descriptions. The defects listed are unique to the element and element material (i.e. concrete, steel, timber, etc.).

- Mortar Breakdown (Masonry) (1610)
- Splits/Spall/Patched Area (1620)
- Masonry or Panel Displacement (1640)

Condition State Commentary

Elements exhibiting damage should report the damage in the note of the report under the defect associated with the damage. For instance traffic impact damage is observed on the fascia of a masonry arch near the roadway. This damage would be recorded in the Masonry Arch element under defect Split/Spall/Patched Area (1620). The inspector would note in the defect notes that the section loss was caused by traffic impact.

The inspector is responsible to carry all necessary equipment to make accurate measurements as necessary.

The defects and condition state definitions are based on the AASHTO Manual for Bridge Element Inspection.

Appendix A defines the Condition States for each individual defect. The defects are expounded on and critical areas are discussed to aid the inspector in determining the severity of a defect. The WisDOT Bridge Inspection Field Manual tabulates the element defects listed above and bases the Condition States on the progression of severity for each defect. The Condition States are comprised of general descriptions and uniquely colored to follow the severity the description represents.

- Condition State 1 Good Green
- Condition State 2 Fair Yellow
- Condition State 3 Poor Orange
- Condition State 4 Severe Red



2.4.7 Other Material Superstructures

This section is the catch-all for all other superstructure primary members comprised of construction materials that cannot be captured under materials previously covered. These materials may include plastic composites or fiber reinforced polymers.

2.4.7.1 Other Closed Web/Box Girder (Element 106)

Other Open Girder (Element 112)

Other Stringer (Element 118)

Other Floor beam (Element 157)

These are primary bending elements for bridges. Closed web/box girders and open girders are longitudinal main members spanning between substructure units. They may sometimes be referred to as beams rather than girders. Stringers are small longitudinal members that span between the floor beams. Floor beams, in turn, span transversely between the main longitudinal girders.

These bending elements are normally rectangular or “tee”-shaped members. On tee-shaped beams, the top flange also functions as the bridge deck. The cross-section of a closed web/box girder may contain several cells, rather than forming a single box shape (if the element comprises the full width of the superstructure Element 65 Other Material Slab should be used). These bridge types may be thought of as a series of “I”-shaped girders lined up side-by-side. As with tee beams, the top flanges of box girders function as the bridge deck.

Element Level Inspection

On the inspection report form, other girders, stringers, and floor beams are recorded in units of lineal feet. Each element may exhibit more than one Condition State along its length. Where multiple condition states exist within a unit of measure only the predominant defect in severity and extent is recorded. The other defects located within the unit of measure shall be captured by the inspector under the element or appropriate defect notes. The sum of all of the reported condition states must equal the total quantity of the element. This will quantify the element’s condition and help generate quantity/cost estimates for future remedial work.

Since each of these elements are bending members, the inspector should expect to find transverse flexural cracks on the top or bottom surfaces in the high moment areas. Diagonal shear cracks on the sides of these elements may also be found at the abutments and piers.

The interior and exterior surfaces of box girders must be inspected in order to properly assign Condition States to the member.

Element Level Inspection of other material closed web/box girders, open girders, stringers, and floor beams should include the following items:

- Checking the entire member for signs of corrosion, as indicated by rust stains or freckled surface rust.
- Inspecting the member for cracks. The inspector should look for transverse flexural cracks on the underside of the beam between supports and on top of the deck over



the piers on continuously supported bridges. Cracks wider than hairline in the flexural region of beams may indicate a serious structural overload.

- Examining the support areas for shear cracks. Shear cracks will be diagonal, extending up from the bearing towards mid-span. Maximum crack widths should be measured and noted on the bridge inspection report.
- Looking for delaminations, spalls, or patching of material. In FRP material looking for blistering (“surface bubbles”), discoloration, or any other type of material deterioration. These defects are an indication of distressed material and may compromise the structural integrity of the member.
- Looking for material deterioration in the form of discoloration, debonding, fraying, etc. For other materials, it may be in the inspector’s best interest to refer to the texture of the material as this may degrade over time.
- Investigating the bearing areas for spalling, crushing, or wrinkling (FRP) to friction from thermal movement or overloads.
- Checking the alignment of the members, verifying there is no bowing, swaying, or other undesirable orientation or movement of the superstructure members.
- Checking the member under drains or leaking expansion joints for cracks, delaminations, rust staining, or efflorescence. Prolonged exposure to moisture may deteriorate the material.
- Checking previously repaired areas for soundness by hammer tapping.
- Looking for collision damage. Fascia beams are most susceptible to vehicular hits. The inspector should take note of the bottom flange to look for any section loss or scraping.

Element Defects

Refer to Appendix A for Defect descriptions. The defects listed are unique to the element and element material (i.e. concrete, steel, timber, etc.).

- Corrosion (1000)
- Cracking (1010)
- Connection (1020)
- Delamination/Spall/Patched Area (1080)
- Deterioration (1220)
- Distortion (1900)



Condition State Commentary

Elements exhibiting damage should report the damage in the note of the report under the defect associated with the damage. For instance, the bottom flange of a beam is struck by vehicular traffic and exhibits deformation out-of-plane. The defect would be reported under Distortion (1900) with the note indicating the deformation was caused by traffic impact.

The inspector is responsible to carry all necessary equipment to make accurate measurements if necessary. Concrete Condition States are dependent on crack width and spall dimensions and depth.

The defects and condition state definitions are based on the AASHTO Manual for Bridge Element Inspection.

Appendix A defines the Condition States for each individual defect. The defects are expounded on and critical areas are discussed to aid the inspector in determining the severity of a defect. The WisDOT Bridge Inspection Field Manual tabulates the element defects listed above and bases the Condition States on the progression of severity for each defect. The Condition States are comprised of general descriptions and uniquely colored to follow the severity the description represents.

- Condition State 1 Good Green
- Condition State 2 Fair Yellow
- Condition State 3 Poor Orange
- Condition State 4 Severe Red



2.4.7.2 Other Truss (Element 136)

This element should be used when a truss is comprised of a construction material not previously covered. This element is not commonly used.

This element includes all primary truss members, including verticals, diagonals, and bottom and top chords. This element should be used for through trusses and deck trusses. The element should be rated on member conditions regardless of protective coating systems.

Element Level Inspection

On the inspection report form, trusses are recorded in units of lineal feet. A truss bridge will have at least two trusses. The correct method to calculate the quantity is to sum of all lengths of each panel as measured longitudinally along the travel way. This element includes all primary components in plane with the truss including, the bottom chord, top chord, verticals and diagonals, as well as bracing member above the roadway on through trusses. The truss components may exhibit more than one Condition State along its length. Distress observed on vertical, diagonal or bracing members shall be reported as the length projected along the length of the truss. Where multiple condition states exist within a unit of measure only the predominant defect in severity and extent is recorded. The other defects located within the unit of measure shall be captured by the inspector under the element or appropriate defect notes. The sum of all of the reported condition states must equal the total quantity of the element. This will quantify the element’s condition and help generate quantity/cost estimates for future remedial work.

Through trusses contain overhead lateral and vertical sway bracing. For through trusses *or through arches*, the upper bracing (lateral, vertical, portal, and sway) will be evaluated and coded under Assessment 9170 – Truss or Arch Overhead Bracing System. All lateral bracing below the roadway will be evaluated under assessment 9169 Lateral Bracing. Refer to Chapter 7, Part 2 for additional information on Assessments. The upper bracing supports the compression members of the truss stabilizing thus making them important members. Its failure could result in the buckling of the compression chord of the truss.

Deck trusses have no bracing located above the roadway. All bracing on deck trusses shall be evaluated as assessment 9169 Lateral Bracing. Refer to Chapter 7, Part 2 for additional information on Assessments.

Truss bottom chord members are located below the deck, exposing them to water, deicing chemicals, roadway debris, and occasionally drift impact from streams below during high water events. The top chord, vertical, and diagonal members are exposed to a less severe environment (except for deck trusses), but are still susceptible to traffic impact and water and deicing agents.

If multiple defects are found within the same unit of measure, the inspector shall record the predominant defect on the inspection report and describe other defects within the notes under the element. The predominant defect is determined first by Condition State. If Condition States of the overlapping defects are equal, the hierarchy then falls to the lowest associated defect number.

Element Level Inspection of other material trusses should include the following items:



- Checking the truss bottom chord members for crushing at the abutments. These are the most suspect areas because they tend to collect and retain the most moisture and debris.
- Looking for any delaminations, spalls, patched areas, or debonding (FRP). Debonding occurring in the vicinity of connectors can be serious if the member is carrying tensile loads.
- Look for fire damage, especially near the abutments and arch bearings where fires can be built close to the primary load-carrying members.
- Checking all members and fasteners for corrosion. The inspector should pay close attention to horizontal prominences with fasteners that can capture debris and moisture.
- Checking fasteners for slipping. Check also for fastener looseness by striking with a hammer. The location of any missing fasteners should be noted.
- Checking the alignment and orientation of members and taking note of any members undergoing distortion. Distortion may be an indication that the member is being overloaded or eccentrically loaded unintentionally.
- Sighting along the length of a truss under traffic loads to look for excessive vertical or lateral deflections. Excessive deflections indicate that the member cannot carry its original design load or that other bridge members are damaged and additional load has shifted to the member in question. The measured or estimated amount of deflection should be recorded.
- Checking for any type of material deterioration (discoloration, wearing, or fraying). These defects are an indication of material distress and may compromise structural integrity.
- Looking for collision damage and reporting this condition under the appropriate Condition State. Signs of impact damage include scrapes on member undersides, chips, cracks, and possibly a permanently displaced or broken member.

Element Defects

Refer to Appendix A for Defect descriptions. The defects listed are unique to the element and element material (i.e. concrete, steel, timber, etc.).

- Corrosion (1000)
- Cracking (1010)
- Connection (1020)
- Delamination/Spall/Patched Area (1080)
- Deterioration (1220)



- Distortion (1900)

Condition State Commentary

Elements exhibiting damage should report the damage in the note of the report under the defect associated with the damage. For instance, the end post of a truss is struck by vehicular traffic and exhibits deformation out-of-plane. The defect would be reported under Distortion (1900) with the note indicating the deformation was caused by traffic impact.

If excessive debris is present on the flanges, cleaning should be recommended under *Maintenance Actions*.

The inspector is responsible to carry all necessary equipment to make accurate measurements if necessary. Concrete Condition States are dependent on crack width and spall dimensions and depth.

The defects and condition state definitions are based on the AASHTO Manual for Bridge Element Inspection.

Appendix A defines the Condition States for each individual defect. The defects are expounded on and critical areas are discussed to aid the inspector in determining the severity of a defect. The WisDOT Bridge Inspection Field Manual tabulates the element defects listed above and bases the Condition States on the progression of severity for each defect. The Condition States are comprised of general descriptions and uniquely colored to follow the severity the description represents.

- Condition State 1 Good Green
- Condition State 2 Fair Yellow
- Condition State 3 Poor Orange
- Condition State 4 Severe Red



2.4.7.3 Other Arch (Element 142)

This element should be used when an arch is comprised of a construction material not previously covered. The other arch element includes the arch ribs, arch diagonals, spandrel columns, spandrel longitudinal bracing, built-up hangers, and tie girders. Lateral bracing between ribs (not of braced ribs) should be assessed under the Lateral Bracing element (9169). This element is not commonly used.

The element should be rated on member conditions regardless of protective coating systems.

Element Level Inspection

On the inspection report form, arches are recorded in units of lineal feet. An arch bridge will have at least two arches. The correct method to calculate the quantity is to sum of all lengths of each panel as measured longitudinally along the travel way. This element includes all primary components in the plane of the arch including all spandrel components (columns, caps and bracing). The arch components may exhibit more than one Condition State along its length. Distress observed on vertical, diagonal or bracing members shall be reported as the length projected along the length of the arch. Where multiple condition states exist within a unit of measure only the predominant defect in severity and extent is recorded. The other defects located within the unit of measure shall be captured by the inspector under the element or appropriate defect notes. The sum of all of the reported condition states must equal the total quantity of the element. This will quantify the element's condition and help generate quantity/cost estimates for future remedial work.

Through arches contain overhead lateral and vertical sway bracing. For through trusses *or through arches*, the upper bracing (lateral, vertical, portal, and sway) will be evaluated and coded under Assessment 9170 – Truss or Arch Overhead Bracing System.. All lateral bracing below the roadway and not between the arch ribs will be evaluated under assessment 9169 Lateral Bracing. Refer to Chapter 7, Part 2 for additional information on Assessments. The upper bracing supports the arch ribs, which are compression members, preventing the ribs from moving out of plane thus making them important members. Its failure could result in the buckling of the arch rib.

Deck arches have no bracing located above the roadway. All bracing on deck arches shall be evaluated under the arch element. Similar to the bracing between arch ribs, all bracing on a deck arch can be viewed as bracing the compression members (arch ribs). Therefore all the bracing on deck arches is considered primary.

Element Level Inspection of other arch ribs should include the following items:

- Checking all primary members for transverse flexural cracking.
- Checking the arch members for crushing at the abutments. These are the most suspect areas because they tend to collect and retain the most moisture and debris.
- Looking for any delaminations, spalls, patched areas or debonding (FRP). Debonding occurring in the vicinity of connectors can be serious if the member is carrying tensile loads.



- Look for fire damage, especially near the abutments and arch bearings where fires can be built close to the primary load-carrying members.
- Checking all members and fasteners for corrosion. The inspector should pay close attention to horizontal prominences with fasteners that can capture debris and moisture.
- Checking fasteners for slipping. Check also for fastener looseness by striking with a hammer. The location of any missing fasteners should be noted.
- Checking the alignment and orientation of members and taking note of any members undergoing distortion. Distortion may be an indication that the member is being overloaded or eccentrically loaded unintentionally.
- Sighting along the length of an arch under traffic loads to look for excessive vertical or lateral deflections. Excessive deflections indicate that the member cannot carry its original design load or that other bridge members are damaged and additional load has shifted to the member in question. The measured or estimated amount of deflection should be recorded.
- Checking for any type of material deterioration (discoloration, wearing, or fraying). These defects are an indication of material distress and may compromise structural integrity.
- Looking for collision damage and reporting this condition under the appropriate Condition State. Signs of impact damage include scrapes on member undersides, chips, cracks, and possibly a permanently displaced or broken member.

Spandrel Components

Vertical spandrel columns of open spandrel arches are primary load-carrying members that support the spandrel bent cap and load the arch ribs.

Spandrel columns are primarily compression members, but they must also resist lateral bending moments due to wind loads, eccentric loading at their tops, overloads, and differential arch deflections.

Element Level Inspection of spandrel columns found on arches should include the following items:

- Checking the arch/spandrel column interface for bearing failures. Bearing failures on timber members loaded parallel to the grain will “broom out”.
- Checking the mid-height of the spandrel column for flexural cracks, which are a sign of structural overloads or differential arch deflection.
- Examining the entire element for signs of deterioration or discoloration.
- Looking for any delaminations, spalls, or debonding of the material.



- Looking for fire damage, especially near the arch bearings where fires can be built close to the primary load-carrying members.
- Checking fasteners (bolts, lag screws) for corrosion or slipping. Check also for fastener looseness by striking with a hammer. The location of any missing fasteners should be noted.
- Sighting along the length of the bridge under traffic loading to look for members aligned out-of-plumb. The column should also be sighted along its length to check for bowing. Excessive deflections indicate that the member has been overstressed or that the bridge is experiencing differential settlements. The measured or estimated amount of deflection should be recorded.

Element Defects

Refer to Appendix A for Defect descriptions. The defects listed are unique to the element and element material (i.e. concrete, steel, timber, etc.).

- Corrosion (1000)
- Cracking (1010)
- Connection (1020)
- Delamination/Spall/Patched Area (1080)
- Deterioration (Other) (1220)
- Distortion (1900)

Condition State Commentary

Elements exhibiting damage should report the damage in the note of the report under the defect associated with the damage. For instance, the rib of a through arch is struck by vehicular traffic and exhibits deformation out-of-pane. The defect would be reported under Distortion (1900) with the note indicating the deformation was caused by traffic impact.

If excessive debris is present on the flanges, cleaning should be recommended under *Maintenance Actions*.

The inspector is responsible to carry all necessary equipment to make accurate measurements if necessary. Concrete Condition States are dependent on crack width and spall dimensions and depth.

The defects and condition state definitions are based on the AASHTO Manual for Bridge Element Inspection.

Appendix A defines the Condition States for each individual defect. The defects are expounded on and critical areas are discussed to aid the inspector in determining the severity of a defect. The WisDOT Bridge Inspection Field Manual tabulates the element defects listed above and bases the Condition States on the progression of severity for each



defect. The Condition States are comprised of general descriptions and uniquely colored to follow the severity the description represents.

- Condition State 1 Good Green
- Condition State 2 Fair Yellow
- Condition State 3 Poor Orange
- Condition State 4 Severe Red



2.4.7.4 Other Primary Structural Members (Element 8170)

This element is for all other superstructure components that cannot be assigned under the previous superstructure categories described within this chapter (girder, stringer, floor beam, truss, arch, etc.). This element is also independent of material type. That is this element may be used to capture a steel, concrete, timber or other material member if necessary if the member does not fall into the .

Purlins, commonly found on steel deck systems of moveable bridges are flexural members that support a grid deck and bear on the stringers of a superstructure floor system. This member would appropriately be captured using the Other Primary Structural Members element.

Diaphragms of curved bridges shall be captured under this element. Diaphragms on curved superstructures are considered primary load carrying members. Due to the lateral and torsional forces the diaphragm resists keeping the girders in alignment make these members primary and must therefore be captured as an element.

Element Level Inspection

On the inspection report form, other primary structural members are recorded in units of lineal feet. The correct method for calculating the element length is the sum of all of the lengths of each appropriate member. Where multiple condition states exist within a unit of measure only the predominant defect in severity and extent is recorded. The other defects located within the unit of measure shall be captured by the inspector under the element or appropriate defect notes. The sum of all of the reported condition states must equal the total quantity of the element. This will quantify the element's condition and help generate quantity/cost estimates for future remedial work.

Element Level Inspection of other structural members should include the following items:

- Checking the entire member for signs of corrosion, as indicated by rust stains or freckled surface rust.
- Inspecting the member for cracks. The inspector should look for transverse flexural cracks on the underside of beam members between supports. Cracks wider than hairline in the flexural region of beams may indicate a serious structural overload.
- Examining the bearing areas for shear cracks. Shear cracks will be diagonal, extending up from the bearing towards mid-span. Maximum crack widths should be measured and noted on the bridge inspection report.
- Looking for delaminations, spalls or patching of material. In FRP material looking for blistering (“surface bubbles”), discoloration or any other type of material deterioration. These defects are an indication of distressed material and may compromise the structural integrity of the member.
- Examining the entire member for signs of decay. Signs include discolored wood with a soft, rotted texture. Look also for fruiting bodies and depressed areas of the wood surface.



- Investigating the bearing areas for spalling, crushing, or wrinkling (in FRP) to friction from thermal movement or overloads.
- Checking the alignment of the members, verifying there is no bowing, swaying or other undesirable orientation or movement of the superstructure members.
- Checking the member under drains or leaking expansion joints for cracks, delaminations, rust staining, or efflorescence.
- Checking for any type of material deterioration (discoloration, wearing, or fraying). These defects are an indication of material distress and may compromise structural integrity.
- Checking all members and fasteners for corrosion. The inspector should pay close attention to horizontal prominences with fasteners that can capture debris and moisture.
- Checking fasteners for slipping. Check also for fastener looseness by striking with a hammer. The location of any missing fasteners should be noted.
- Checking previously repaired areas for soundness by hammer tapping.
- Looking for collision damage. Fascia beams are most susceptible to vehicular hits. The inspector should take note of the bottom flange to look for any section loss or scraping.

Element Defects

Refer to Appendix A for Defect descriptions. The defects listed are unique to the element and element material (i.e. concrete, steel, timber, etc.).

- Corrosion (1000)
- Cracking (1010)
- Connection (1020)
- Delamination/Spall/Patched Area (1080)
- Exposed Rebar (1090)
- Exposed Prestressing (1100)
- Cracking (PSC) (1110)
- Cracking (RC and Other) (1130)
- Decay/Section Loss (1140)
- Check/Shake/Split/Delamination (1150)



- Abrasion/Wear (1180)
- Deterioration (1220)
- Distortion (1900)

Condition State Commentary

Cracks or fractures should be measured and clearly marked and dated when observed to establish a reference for future inspections. Defects that appear to be affecting the structural integrity of the structure or are posing a threat to public safety should be brought up with the Program Manager immediately.

Elements exhibiting damage should report the damage in the note of the report under the defect associated with the damage. For instance, the end post of a truss is struck by vehicular traffic and exhibits deformation out-of-plane. The defect would be reported under Distortion (1900) with the note indicating the deformation was caused by traffic impact.

If excessive debris is present on the flanges, cleaning should be recommended under *Maintenance Actions*.

The inspector is responsible to carry all necessary equipment to make accurate measurements if necessary. Concrete Condition States are dependent on crack width and spall dimensions and depth.

The defects and condition state definitions are based on the AASHTO Manual for Bridge Element Inspection.

Appendix A defines the Condition States for each individual defect. The defects are expounded on and critical areas are discussed to aid the inspector in determining the severity of a defect. The WisDOT Bridge Inspection Field Manual tabulates the element defects listed above and bases the Condition States on the progression of severity for each defect. The Condition States are comprised of general descriptions and uniquely colored to follow the severity the description represents.

- Condition State 1 Good Green
- Condition State 2 Fair Yellow
- Condition State 3 Poor Orange
- Condition State 4 Severe Red

2.4.8 Bearing Elements

Bearings serve as the interface between the superstructure girders and the substructure. Bearings carry the dead loads and live loads from the girders down to the substructure and also accommodate bridge rotation, expansion, and contraction. Bridge movement can result from temperature changes, substructure movement, live and dead load deflections, wind loads, quick braking of a vehicle, etc. Movable (expansion) bearings accommodate superstructure longitudinal and rotational movements. Fixed bearings accommodate superstructure rotational movements only. Both types of bearings resist transverse and vertical bridge movements.

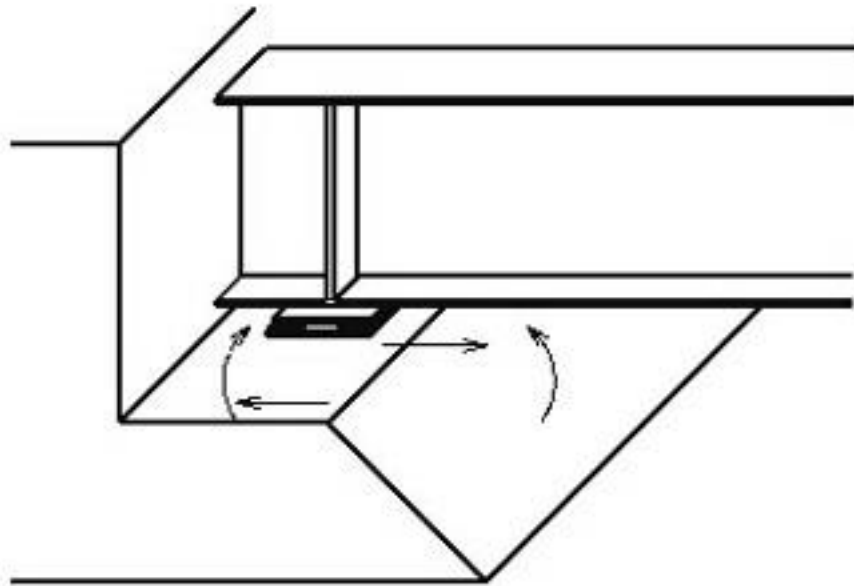

Figure 2.4.6-1: Range of Motion of an Expansion Bearing.

There are several bearing types, but there are four basic bearing elements.

1. **Sole plate:** this is a steel plate attached to the bottom flange of a girder or to a truss member, or may be embedded within a prestressed girder. It serves to transmit the girder reaction force from the girder to the bearing device and may also serve to stiffen the flanges of steel girders.
2. **Bearing device:** bearing devices transmit the girder reaction force from the sole plate to the masonry plate. They can be any of a number of materials and serve several different functions. Expansion bearing devices include rockers, rollers, sliding bronze or steel plates, sliding Teflon plates, thick deformable elastomeric pads, or pot bearings. Fixed bearing devices include bearing shoes, rocker plates, thin non-deformable elastomeric pads or simply a layer of compressible material such as cork or asphalt impregnated joint filler.



3. **Masonry plate:** a steel plate that distributes the forces from the bearing device to the substructure. They are called “masonry” plates because they are placed on top of the concrete masonry of the substructure units. There may be a lead sheet or other material placed below this plate to more evenly distribute the bearing stresses over the possible irregular surface of the concrete.
4. **Anchorage:** longitudinal forces, lateral forces, and sometimes uplift forces act on the bearings. If not restrained, these forces may cause parts of the bearing assembly (most often the masonry plate) to “walk out” from under the bearing device. Anchorages secure the elements of the bearing assembly to the substructure and also to contain bearing components not secured to the substructure from shifting. Most often, the anchorage system consists simply of anchor bolts and nuts to secure the masonry plate. Current American Association of State Transportation and Highway Officials (AASHTO) design standards require that anchor bolts be a minimum of 1 inch in diameter. They may be embedded within the substructure concrete or bolted to steel or timber substructures. Retainer angles or bars may also be used to prevent the bearing device or girder from walking out or moving laterally.

Not all bearings will have all four of the basic bearing elements. As a minimum, however, a compressive filler or thin pad will usually be found between the superstructure and substructure.

2.4.8.1 Elastomeric Bearing (Element 310)

Elastomeric bearings are made of neoprene rubber. Depending on the thickness and construction, they can be used for either fixed or expansion bearings. They may be the only component of a bearing assembly, but sometimes a sole plate is used. Elastomeric bearings are often bonded to the substructure by means of an adhesive and may be vulcanized to the sole plate. They are an attractive choice for a bearing system because they do not corrode and have a long life span if properly designed.

Fixed elastomeric bearings use thin (approximately ½ to 1 inch) rectangular pads made of plain neoprene. They have little lateral movement capability and may be found on short spans or prestressed concrete bridges. **Wisconsin does not code these thin elastomeric bearing pads as a specific element, but assesses their condition as part of the superstructure element.**

Expansion elastomeric bearings are thick rectangular pads that accommodate longitudinal and rotational superstructure movements through shear deformations. Expansion elastomeric bearings may be plain or laminated. Plain pads are used for shorter span bridges with small longitudinal movements and small reaction loads. Under large longitudinal movements, plain pads will deform excessively and their edges will tend to roll off the substructure, resulting in larger bearing pressures and wear. Large reaction loads will cause plain pads to excessively deform vertically, excessively bulge, and possibly split. To guard against these undesirable situations, many expansion elastomeric pads are laminated with steel plates. Laminated pads can be built up higher than 1 inch, which gives them a higher deformation threshold. The steel plates control the amount the elastomeric material is allowed to bulge, thereby controlling vertical deflections. Often, the plates will not be visible because they are encapsulated within the pad with a thin elastomer side covering.



Element Level Inspection

This element encompasses those bearings that are primarily composed of elastomers, with or without metal or fabric reinforcement.

On the inspection report form, bearings are recorded in units of each. The correct method for calculating the total quantity is the sum of the bearing assemblies throughout the structure. Where multiple condition states exist within a unit of measure only the predominant defect in severity and extent is recorded. For a bearing, only one defect will be applied to each bearing assembly. Therefore it is the inspector's responsibility to determine the predominant defect for the entire assembly. The other defects located within the unit of measure shall be captured by the inspector under the element or appropriate defect notes. The sum of all of the reported condition states must equal the total quantity of the element. This will quantify the element's condition and help generate quantity/cost estimates for future remedial work.

Maintenance inspection of elastomeric bearings should include the following items:

- Checking the sole plate and/or masonry plate, if any are present, for corrosion. Excessive corrosion may lead to a breakdown or failure of the plate's connection to the elastomeric material.
- Checking for excessive bulging on the sides of the pad. Bulging in excess of about 15 percent of the pad's thickness is a cause for concern. This could be due to excessive vertical loads combined with excessive girder rotation. Bulging on laminated pads should only occur within the individual layers of elastomer.
- Checking for any uplift along the bottom edges. This could be the result of excessive shear, rotation or a combination of both.
- Looking for splits or tears in the pad. These may be oriented vertically or horizontally. If a laminated pad was poorly constructed, the reinforcement layers can start to separate from the elastomer, resulting in horizontal splits. This is a serious condition and should be reported.
- Checking for pad misalignments from its original position. This indicates that it is no longer bonded to the sole plate or substructure, and is beginning to walk out from under the girder.
- Measuring the amount of longitudinal expansion/contraction in expansion bearings. This horizontal measurement is taken between the top and bottom edges of the pad. Longitudinal displacement should have an upper limit of about 25 percent of the bearing pad height. Displacement beyond this limit contributes to high shear stresses and can result in bearing deterioration. An example of the measurement to be taken is shown in Figure 2.4.6.1-1. The ambient temperature at which measurements were taken should be recorded as well.
- Measuring the rotation of the pad if the pad height is vastly different from front to back. The height at the front and back should be recorded, as should the pad length from front to back. An angle of rotation can then be calculated. An example of the measurements to be taken is shown in Figure 2.4.8.1-1.

- Checking for variable thickness in the lateral direction, suggesting lateral rocking of the girder. This would be an unusual occurrence, and signs of distress in other parts of the bridge should be investigated as well.
- Looking for excessive wear at the interface with the sole and/or masonry plates. This may be caused by several expansion/contraction cycles.
- Checking for signs of pad debonding from the sole plate, masonry plate or substructure concrete. The bearing pads should be in full contact with the sole plate and the masonry plate or substructure surface. Should the pad become completely torn from one of these surfaces, it could begin to walk out from under the girder. Out-of-position pads are a potentially serious condition and should be reported to the Inspection Program Manager.
- Checking for cracking or spalling of the abutment and pier surfaces near the bearing pad.
- Checking for any elongation of the pad length at the masonry plate for plain pads. Elongation is the result of increased shear strain that can lead to shear failure. If a plain pad is designed/constructed too thick or if the bearing loads are too high, the pad may exhibit bulging or splits.

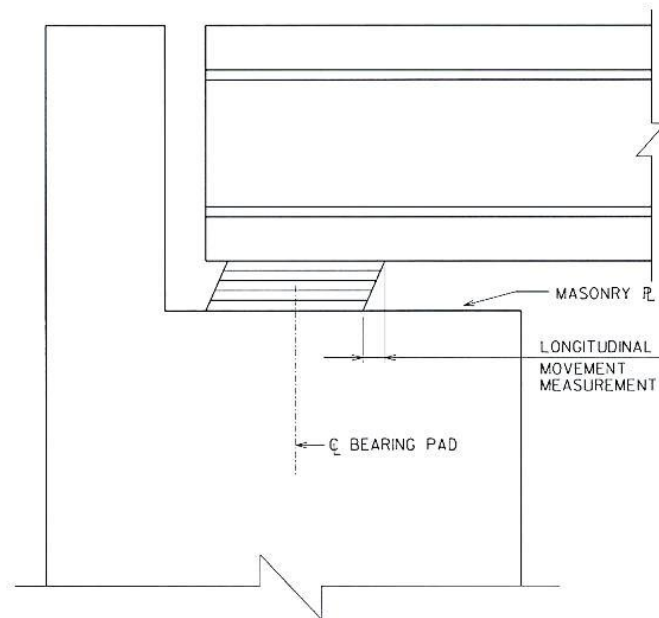

Figure 2.4.8.1-1: Elastomeric Bearing Movement Measurement.

Element Defects

Refer to Appendix A for Defect descriptions. The defects listed are unique to the element and element material (i.e. concrete, steel, timber, etc.).



- Corrosion (1120)
- Connection (1140)
- Movement (2210)
- Alignment (2220)
- Bulging, Splitting or Tearing (2230)
- Loss of Bearing Area (2240)

Condition State Commentary

The inspector is responsible to carry all necessary equipment to make accurate measurements if necessary. The inspector should make every available attempt to measure the expansion, contraction, rotation or bulging of the bearing.

The defects and condition state definitions are based on the AASHTO Manual for Bridge Element Inspection.

Appendix A defines the Condition States for each individual defect. The defects are expounded on and critical areas are discussed to aid the inspector in determining the severity of a defect. The WisDOT Bridge Inspection Field Manual tabulates the element defects listed above and bases the Condition States on the progression of severity for each defect. The Condition States are comprised of general descriptions and uniquely colored to follow the severity the description represents.

- Condition State 1 Good Green
- Condition State 2 Fair Yellow
- Condition State 3 Poor Orange
- Condition State 4 Severe Red



Figure 2.4.6.1-2: Elastomeric Bearing - Condition State 1.



Figure 2.4.6.1-3: Elastomeric Bearing Experiencing Shear Deformation – Condition State 1.



Figure 2.4.6.1-4: Uplift at Corner of Elastomeric Bearing – Movement Condition State 2.



2.4.8.2 Movable Bearing (Element 311)

There are several types of movable steel bearings that are used to support bridge superstructures. These include rollers, rockers, and sliding plates. Movable bearings are designed to accommodate superstructure expansion, contraction, and rotation. Corrosion is often a problem with movable bearings because they are always used at expansion joints. When these joints leak, water, deicing chemicals, and road debris are allowed to fall directly onto the bearing assemblies.

Rockers

Rockers are steel devices that pivot and roll to accommodate superstructure expansion and contraction. The pivot point/center of rotation is located at the sole plate and longitudinally moves along with the end of the girder. The bottom of a rocker rolls along top of the masonry plate.

Rockers are usually wedge-shaped bearings of variable size. They are used to accommodate large girder reactions in conjunction with large superstructure longitudinal movements. Pintles are often used to hold the rocker in place at the masonry plate. Pintles are short steel pins press fitted into the masonry plate. The pintles fit into oversize holes drilled into the rocker's rolling surface. A pin is sometimes used to connect the rocker to the sole plate. More often, the top stem of the rocker is cast or machined into a cylindrical shape, and the stem fits into a pocket formed in the sole plate. Both pins and stems help to maintain the bearing alignment.

Rollers

Rollers are steel cylinders or segments of cylinders that roll between the sole and masonry plates as the superstructure expands and contracts. Two types of roller bearing assemblies may be found.

1. Roller nest: a nest is a series of small rollers, 1.5 to 2 inches in diameter, assembled together in a fixture. A pin at the top of the fixture allows rotation of the superstructure. Nests often fail because the small diameter rollers offer many places for dirt and debris to accumulate. The dirt and debris will not allow the rollers to roll properly, will trap moisture, and will cause corrosion. Roller nests were widely used around the beginning of the twentieth century, but are no longer used for new construction due to their inherent maintenance problems.
2. Single roller: the single roller is a widely used bearing. A steel cylinder, usually between 6 and 15 inches in diameter, functions as the bearing surface or roller. To keep a roller from walking out over time, flanges are used at their ends that straddle the sole and masonry plates. Pintles press fitted into the roller may also be used. Corrosion on a roller bearing begins at the contact areas between the roller and the plates from trapped dirt, debris, and moisture. When corrosion or proper movement becomes a problem, larger rollers can often be cleaned, rotated 90 degrees, and reused. Smaller rollers tend to corrode uniformly, and must usually be replaced.



Sliding Plates

Sliding plate bearings are typically used on spans under 40 feet. A number of different sliding plate configurations that have been used.

1. Lubricated steel plates: this type of bearing consists of two sliding steel plates, usually the sole plate and masonry plate. After the masonry plate is set in position on top of the substructure, a lubricant consisting of grease, graphite and tallow is applied to the sliding surface. The girder/sole plate is then set on top. The system works well until the lubricant collects dirt and debris. These foreign particles have a tendency to hold moisture, which eventually causes the plates to corrode and bind together, resisting movement. Past attempts to remedy this problem included using a small plate to slide against a larger one, thereby reducing the area of contact available for corrosion. Unfortunately, the smaller plate tended to wear a groove in the larger one. These are older details no longer used in new construction.
2. Lead sheets: a layer of lead sheet was once used between the steel sliding plates to prevent them from corroding together. The lead sheet, however, tended to walk out over time.
3. Asbestos sheet packing: graphite impregnated asbestos sheets have been used in a manner similar to lead sheets.
4. Roofing felt/tar paper: oil-soaked roofing felt or tarpaper has been used in conjunction with graphite to provide movement for small concrete bridges. Several layers of the felt/paper are placed directly on top of the substructure concrete, and the slab or girders are placed directly on top.
5. Bronze bearing plates: bronze plates were used because they corroded less dramatically than steel. However, because bronze is softer than steel and tends to wear faster, dirt and debris between the plates often caused rapid deterioration of the metal, leading to binding.
6. Lubricated bronze plates: lubricant can minimize the problem of mechanical wear and locking up. Dimples cut into a bronze bearing plate act as small pots to hold a graphite lubricant. As the bearing plate wears down, the lubricant is constantly applied to the bearing surfaces. However, the lubricant can eventually wear out and the bearing may still bind over time. As a result, these bearings should be periodically re-lubricated. In Wisconsin, the standard bronze sliding bearing has no dimples. The sole plate has a thin plate of finished stainless steel welded to it that rides over the bronze bearing plate. In order to accommodate rotation, a curved rocker plate is placed beneath the bearing plate, and pintles keep it aligned. Keeper bars and ridges on the rocker plate restrain the bearing plate from walking out of position.
7. PTFE on stainless steel: Polytetrafluoroethylene (PTFE) is commonly known by its trade name, Teflon. Teflon has a very low coefficient of friction, which makes it an ideal material for a sliding bearing. In Wisconsin, the standard PTFE sliding bearing has a thin surface of Teflon bonded to a steel bearing plate. The sole plate has a thin plate of finished stainless steel welded to it that rides over the Teflon. In order to accommodate rotation, a curved rocker plate is placed beneath the bearing plate, and

pintles keep it aligned. Keeper bars and ridges on the rocker plate restrain the bearing plate from walking out of position.

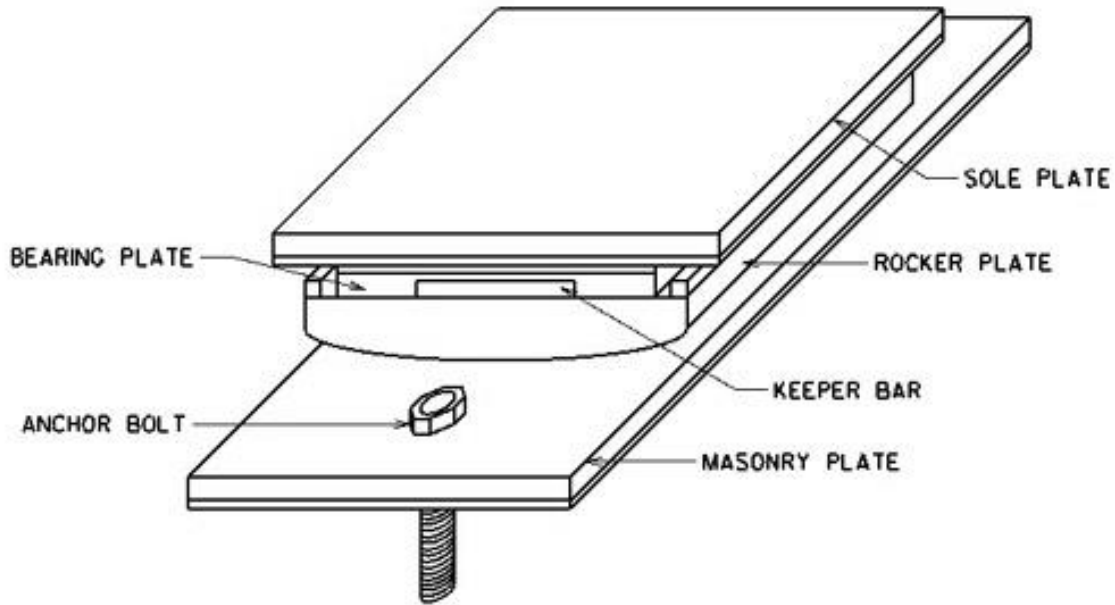

Figure 2.4.8.2-1: Sliding Plate Bearing.

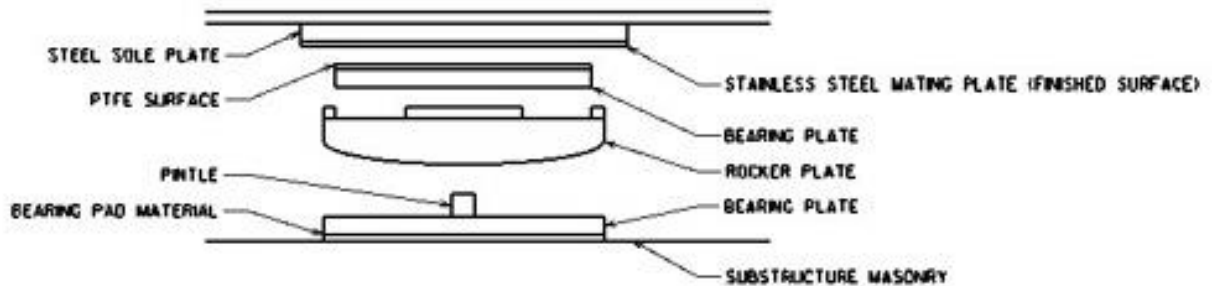

Figure 2.4.8.2-2: PTFE Sliding Plate Bearing Components.

When the main span length is substantially greater than the approach span lengths of continuous bridges, girder ends at the abutments may actually experience uplift forces at the abutments. This could occur when high live loads are placed on the main span but not on the approach spans. It is normally only a problem for steel superstructures because of their lighter dead loads compared to concrete. To prevent physical uplift of the girders at the abutments, restraining or hold-down bearings are used. Restraining bearings consist of large pins inserted through the girder web, with the ends of the pin linked with steel plates to the masonry plate. On large structures such as cantilever trusses or cantilever arches, link bars



may be used at the hold down end of the anchor span. Link bars work in a manner similar to pin and hanger assemblies, but they hold a span down instead of suspending it.

Element Level Inspection

This element encompasses those bearings that provide a superstructure component both rotational and longitudinal movement by means of roller, rocker or sliding assembly.

On the inspection report form, bearings are recorded in units of each. The correct method for calculating the total quantity is the sum of the bearing assemblies throughout the structure. Where multiple condition states exist within a unit of measure only the predominant defect in severity and extent is recorded. For a bearing, only one defect will be applied to each bearing assembly. Therefore it is the inspector's responsibility to determine the predominant defect for the entire assembly. The other defects located within the unit of measure shall be captured by the inspector under the element or appropriate defect notes. The sum of all of the reported condition states must equal the total quantity of the element. This will quantify the element's condition and help generate quantity/cost estimates for future remedial work.

Maintenance inspection of movable bearings should include the following items:

- Looking for deteriorated or spalled concrete underneath of the masonry plate. This reduces the bearing area and increases bearing stress on the concrete. It is a common occurrence when the masonry plate has been placed too close to the edge of the substructure unit. Concrete deterioration may also indicate the bearing is not handling lateral forces as intended.
- Looking for anchor bolts/nuts which have risen up above the masonry plate. This is usually caused by water from leaky expansion joints that has migrated into the embedment space of the bolt, froze, expanded, and pushed the bolt upward. Check also for bent anchor bolts.
- Looking for masonry plates that are walking out from underneath of sliding plate bearings. When sliding plates lose their lubrication, substantial longitudinal forces are developed. The forces may be large enough to shear off anchor bolts and push the masonry plate during superstructure expansion and contraction cycles.
- Noting pack rust between sliding plates or between the masonry plate and rocker or roller. Pack rust can freeze up a movable bearing and prevent it from operating properly.
- Noting debris located under a rocker or roller that may be hindering its rolling movement.
- Checking for any broken keeper bars or retainer angles. These deficiencies may allow bearing components to walk out over time.
- Looking for signs of proper movement/wear on sliding plates. On bronze plates, proper movement may be indicated by longitudinal scrape marks or clean bronze. Surface rust ground off steel components of the bearing adjacent to the sliding



surface is also a sign the bearing is operating properly. The lack of these signs suggests a frozen bearing.

- Taking expansion/contraction measurements on bearings. Measurements should be made to the nearest 1/8 inch. Examples of measurements to be taken are shown in Figure 2.4.8.2-3. The ambient temperature at which the expansion/contraction measurement is taken should be recorded as well.
- Checking the bearing assembly for excessive corrosion that may be reducing the cross-sectional area of the bearing device or anchor bolts. Also, excessive corrosion on the bearing surface of masonry plates will inhibit smooth rolling action of rollers and rockers.
- Looking for full and even contact of all bearing components. Gaps or uplift between the bearing surfaces should not be present. A bearing having only partial contact exerts higher stresses on all assembly components. This could result in concrete crushing or steel component buckling.
- Looking and listening for signs of bearing looseness, such as visual movements or rattling under live loads, uplift, and loose or missing fasteners/welds.
- Checking for broken or loose pintles, if visible. This situation suggests excessive superstructure movements (longitudinal or lateral) or substructure settlements.
- Checking for proper bearing alignment. Improper alignments suggest a failing bearing, excessive superstructure movement, or substructure settlement. One sign of improper alignment for any bearing is a superstructure that is tight against the backwall of the abutment. Other signs for specific bearing types are described below.
 - a. Sliding plates: there should be no exposure of the sliding surface on the smaller sliding plate. Look for excessive overhang of the top sliding plate over the bottom sliding plate. Improper alignment may allow the girder to slide off the bearing plate on days of temperature extremes. The sole plate of a sliding plate bearing should normally line up with the masonry plate between temperatures of 60 to 70 degrees Fahrenheit, although this could vary for an individual bridge.
 - b. Rockers: rockers should be tipped in the proper direction for the ambient temperature. The top of the rocker should be tipped away from the fixed bearing on hot days and towards the fixed bearing on cold days. Rockers are normally set vertical between temperatures of 60 to 70 degrees Fahrenheit, although this could vary for an individual bridge. Excessive tipping in the proper direction for the ambient temperature is also undesirable. Improper alignment may allow the rocker to roll off its bearing surface on days of temperature extremes, allowing the superstructure to drop several inches.
 - c. Rollers: the bearing point of rollers on the masonry plate should be located in the proper position for the ambient temperature. The roller should be rolled away from the fixed bearing on hot days and towards the fixed bearing on cold days. Rollers are normally positioned on the centerline of the masonry plate between temperatures of 45 to 65 degrees Fahrenheit. Excessive movement in the proper

direction for the ambient temperature is also undesirable. Improper alignment may allow the roller to roll off of its bearing surface or roll out from under the girder on days of temperature extremes, allowing the superstructure to drop several inches.

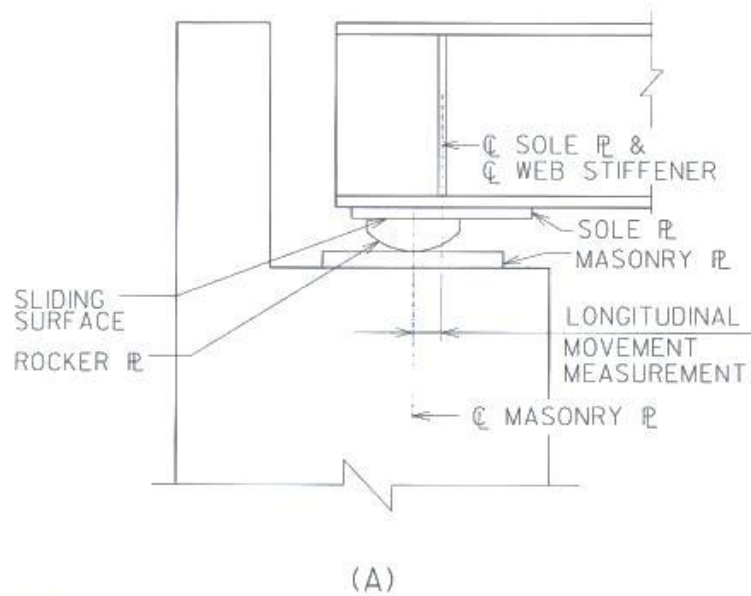

Figure 2.4.8.2-3: Expansion Bearing Movement Measurements.

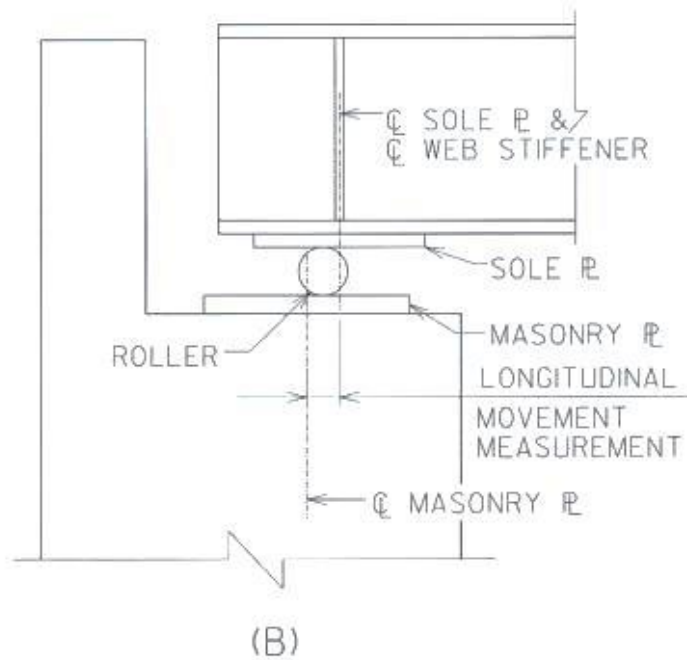

Figure 2.4.8.2-4: Expansion Bearing Movement Measurements.

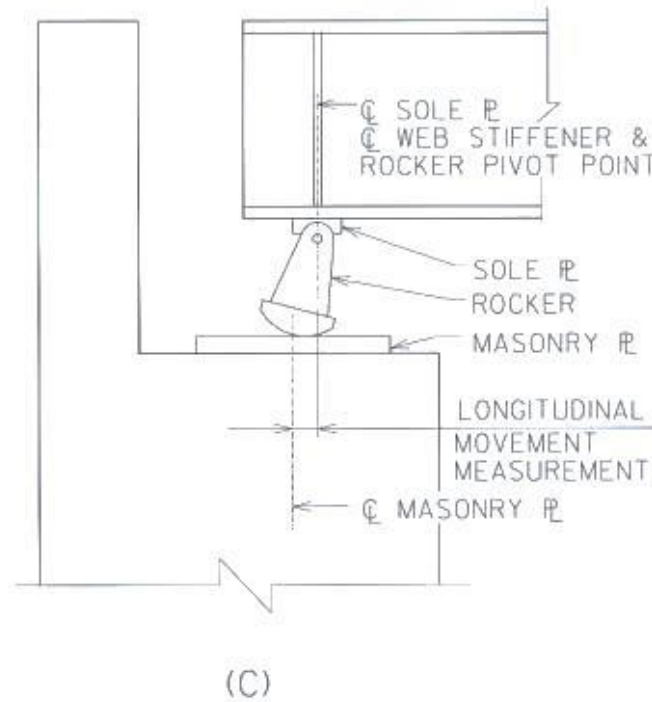

Figure 2.4.8.2-5: Expansion Bearing Movement Measurements.

Element Defects

Refer to Appendix A for Defect descriptions. The defects listed are unique to the element and element material (i.e. concrete, steel, timber, etc.).

- Corrosion (1000)
- Connection (1020)
- Movement (2210)
- Alignment (2220)
- Loss of Bearing Area (2240)

Condition State Commentary

The defects and condition state definitions are based on the AASHTO Manual for Bridge Element Inspection.

Appendix A defines the Condition States for each individual defect. The defects are expounded on and critical areas are discussed to aid the inspector in determining the severity of a defect. The WisDOT Bridge Inspection Field Manual tabulates the element defects listed above and bases the Condition States on the progression of severity for each

defect. The Condition States are comprised of general descriptions and uniquely colored to follow the severity the description represents.

- Condition State 1 Good Green
- Condition State 2 Fair Yellow
- Condition State 3 Poor Orange
- Condition State 4 Severe Red



Figure 2.4.8.2-6: Rocker Bearing – Condition State 1.



Figure 2.4.8.2-7: Rocker – Loss of Bearing Area Condition State 2



Figure 2.4.8.2-8: Rocker Bearing – Corrosion Condition State 2.



Figure 2.4.8.2-9: Rocker Bearing – Condition State 2.

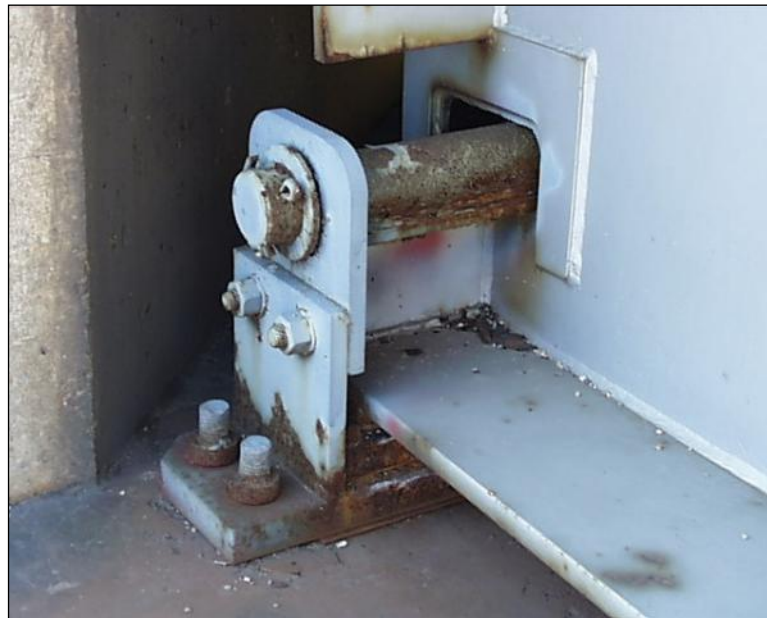

Figure 2.4.8.2-10: Hold-Down (Restraining) Bearing - Corrosion Condition State 2.



Figure 2.4.8.2-11: Critically Misaligned Roller Bearing – Alignment Condition State 3.



Figure 2.4.8.2-12: Rocker Bearing – Movement Condition State 3.



Figure 2.4.8.2-13: Masonry Plate Walking Out Due to Failed Anchor Bolt – Connection Condition State 3.



Figure 2.4.8.2-14: Masonry Plate Walkout Due to Failed Anchor Bolt – Connection Condition State 3.



Figure 2.4.8.2-15: Severely Tipped Sliding Bearing – Movement Condition State 3.



2.4.8.3 Fixed Bearing (Element 313)

Fixed bearings prevent longitudinal or transverse movement of the supported element. The sole purpose of a fixed bearing is to transfer load from the superstructure to the substructure while allowing for rotation of the supported element.

Fixed bearings are very simple elements. Those carrying relatively light reaction loads may consist of a sole plate with a curved underside that bears on a masonry plate. For larger bridges and reaction loads, large cast or fabricated fixed shoes are used. Fixed shoes have either a bearing pin or cylindrical shaped stem at their tops. The sole plate has a curved pocket to receive the pin or stem. Fixed shoes widen out at their bases for better load distribution. They are connected to the masonry plate.

Element Level Inspection

This element encompasses those bearings that are fixed and only provide rotation of the superstructure and not expansion and contraction. This element should be used for box girder hinges.

On the inspection report form, bearings are recorded in units of each. The correct method for calculating the total quantity is the sum of the bearing assemblies throughout the structure. Where multiple condition states exist within a unit of measure only the predominant defect in severity and extent is recorded. For a bearing, only one defect will be applied to each bearing assembly. Therefore it is the inspector's responsibility to determine the predominant defect for the entire assembly. The other defects located within the unit of measure shall be captured by the inspector under the element or appropriate defect notes. The sum of all of the reported condition states must equal the total quantity of the element. This will quantify the element's condition and help generate quantity/cost estimates for future remedial work.

Maintenance inspection of fixed bearings includes the following items:

- Checking for detachment of the masonry plate or fixed shoe to the substructure. This may be evident by a gap/uplift between the plate and substructure or anchor bolts that are bent, sheared off or pulled out of the substructure concrete.
- Looking for deteriorated or spalled concrete underneath of the masonry plate. This reduces the bearing area and increases bearing stress on the concrete. It is a common occurrence when the masonry plate has been placed too close to the edge of the substructure unit.
- Looking for corrosion on the pins, stem, or bearing surfaces. Advanced corrosion can cause a fixed bearing to resist rotation and may reduce the cross-sectional area of the bearing device or anchor bolts.
- Looking for signs of lateral movement.
- Looking and listening for signs of bearing looseness, such as visual movements or rattling under live loads, uplift, and loose or missing fasteners/welds.



Element Defects

Refer to Appendix A for Defect descriptions. The defects listed are unique to the element and element material (i.e. concrete, steel, timber, etc.).

- Corrosion (1000)
- Connection (1020)
- Movement (2210)
- Alignment (2220)
- Loss of Bearing Area (2240)

Condition State Commentary

The defects and condition state definitions are based on the AASHTO Manual for Bridge Element Inspection.

Appendix A defines the Condition States for each individual defect. The defects are expounded on and critical areas are discussed to aid the inspector in determining the severity of a defect. The WisDOT Bridge Inspection Field Manual tabulates the element defects listed above and bases the Condition States on the progression of severity for each defect. The Condition States are comprised of general descriptions and uniquely colored to follow the severity the description represents.

- Condition State 1 Good Green
- Condition State 2 Fair Yellow
- Condition State 3 Poor Orange
- Condition State 4 Severe Red



Figure 2.4.8.3-1: Fixed Shoe Bearing - Condition State 1.



Figure 2.4.8.3-2: Slight Uplift on Masonry Plate – Movement Condition State 2.



2.4.8.4 Pot Bearing (Element 314)

Pot bearings are often used for large curved bridges where the directions for lateral movement and rotation axes are less certain than on straight bridges. They have large bearing capacities and may be designed as fixed bearings as well. Corrosion is often a problem with movable pot bearings because they are always used at expansion joints. When these joints leak, water, deicing chemicals, and road debris are allowed to fall directly onto the bearing assemblies.

Pot bearings allow large multidimensional rotations and lateral movements of the superstructure. Two types of pot bearings may be found.

1. **Neoprene:** These types of pot bearings have several components, including a shallow steel cylinder or hollowed out plate called the pot or pot base, a thin neoprene pad, a steel piston, and a steel top plate. The neoprene pad fits tightly within the pot, and the piston is set on top of the neoprene. The top plate (sole plate), which receives the girder loads, is set on top of the piston. Because of the neoprene pad's tight fit within the pot, deformations are controlled. This allows the pad to withstand much higher loads than an unconfined pad, which would be allowed to bulge. The pad behaves in a manner similar to hydraulic fluid, allowing rotational movements in any direction. Since neoprene pad confinement is critical to the proper operation of a pot bearing, brass seal rings are set between the cylinder and piston. These prevent the neoprene from extruding out of the pot under high loads. To accommodate lateral movements on expansion pot bearings, a Teflon disk is adhered to the top of the piston, and stainless steel is attached to the underside of the top plate.
2. **Spherical:** These types of pot bearings also have several components, including a shallow steel cylinder or hollowed out plate called the pot or pot base, a dished aluminum alloy casting, an aluminum alloy top casting with flat top and spherical bottom, and a steel top plate (sole plate). Teflon sheets are adhered to the curved surfaces of the aluminum alloy castings. The aluminum alloy bottom casting is set into the pot, and the aluminum alloy top casting is set into the bottom casting. The two castings work together like a ball-and-socket joint, accommodating rotational movements in any direction. The top plate sits on top of the top casting. To accommodate lateral movements on expansion pot bearings, a Teflon disk is adhered to the top aluminum alloy casting, and stainless steel is attached to the underside of the top plate.

Element Level Inspection

This element encompasses those bearings that contain confined elastomeric material or configured with a pot base (uncommon spherical pot bearings which do not contain elastomeric material would be assessed under this element). The bearing assemblies may be fixed against horizontal movement, fitted with guide bars to prevent movement in one horizontal direction or floating to allow free horizontal movement depending on the application.

On the inspection report form, bearings are recorded in units of each. The correct method for calculating the total quantity is the sum of the bearing assemblies throughout the structure. Where multiple condition states exist within a unit of measure only the predominant defect in



severity and extent is recorded. For a bearing, only one defect will be applied to each bearing assembly. Therefore it is the inspector's responsibility to determine the predominant defect for the entire assembly. The other defects located within the unit of measure shall be captured by the inspector under the element or appropriate defect notes. The sum of all of the reported condition states must equal the total quantity of the element. This will quantify the element's condition and help generate quantity/cost estimates for future remedial work.

Due to their limited height and confinement of working parts, pot bearings are often difficult to inspect. However, movement related items can be inspected. Maintenance inspection of pot bearings should include the following items:

- Checking for neoprene pad extrusion above the pot rim, as this indicates serious distress.
- Looking for wear or binding on guide bars. Guide bars are sometimes used on expansion pot bearings to restrict lateral movements in the transverse direction.
- Checking for proper bearing alignment. Improper alignments suggest a failing bearing, excessive superstructure movement, or substructure settlement. One sign of improper alignment is a superstructure that is tight against the backwall of the abutment. There should also be no exposure of the piston top or top surface of the top aluminum alloy casting. Look for excessive overhang of the top sliding plate over the piston or top aluminum alloy casting. Improper alignment may allow the girder to slide off of the bearing plate on days of temperature extremes. The top plate and pot should normally line up between temperatures of 60 to 70 degrees Fahrenheit, although this could vary for any individual bridge.
- Taking expansion/contraction measurements on bearings that are improperly aligned. An example of the measurements to be taken is shown in Figure 2.4.8.4-1. Lateral movements should also be measured. The ambient temperature at which the expansion/contraction measurements are taken should be recorded as well.
- Taking rotation measurements on bearings that are improperly aligned. An example of the measurements to be taken is shown in Figure 2.4.8.4-1.
- Looking for corrosion, pitting, or section loss on the components or bearing surfaces. Advanced corrosion can cause a bearing to resist intended movement and may reduce the cross-sectional area of the bearing devices.
- Checking the bearing components for proper seating and alignment with one another.
- Looking for debris build up that would inhibit proper bearing operation.
- Looking for any cracked welds.
- Looking and listening for signs of bearing looseness, such as visual movements or rattling under live loads, uplift, and loose or missing fasteners/welds.

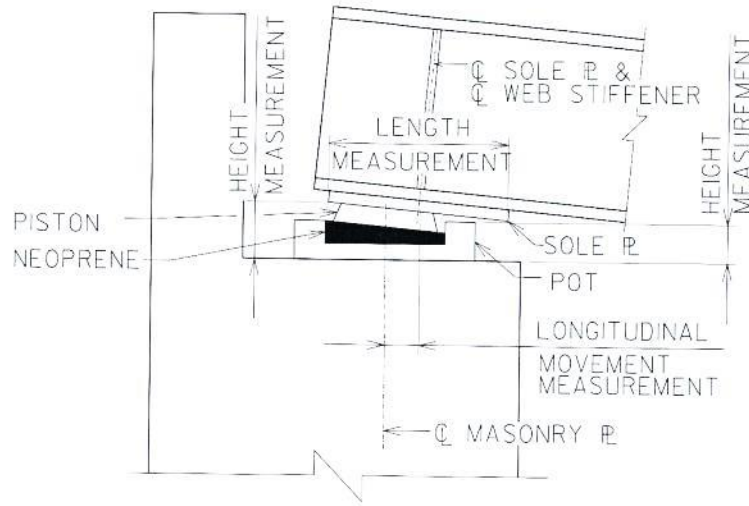

Figure 2.4.8.4-1: Pot Bearing Lateral Movement and Rotation Measurements.

Element Defects

Refer to Appendix A for Defect descriptions. The defects listed are unique to the element and element material (i.e. concrete, steel, timber, etc.).

- Corrosion (1000)
- Connection (1020)
- Movement (2210)
- Alignment (2220)
- Bulging, Splitting or Tearing (2230)
- Loss of Bearing Area (2240)

Condition State Commentary

The defects and condition state definitions are based on the AASHTO Manual for Bridge Element Inspection.

Appendix A defines the Condition States for each individual defect. The defects are expounded on and critical areas are discussed to aid the inspector in determining the severity of a defect. The WisDOT Bridge Inspection Field Manual tabulates the element defects listed above and bases the Condition States on the progression of severity for each defect. The Condition States are comprised of general descriptions and uniquely colored to follow the severity the description represents.

- Condition State 1 Good Green
- Condition State 2 Fair Yellow



- Condition State 3 Poor Orange
- Condition State 4 Severe Red



Figure 2.4.8.4-2: Tipped Pot Bearing – Movement Condition State 2.



2.4.8.5 Disk Bearing (Element 315)

Similar to pot bearings, disk bearings are low profile. However, the disk bearing device is different than a pot bearing. A sole plate rests on top of a polyether urethane disk. The disk rests on top of a masonry plate that then distributes the load to the substructure. In fixed applications a shear pin with a rounded tip, fixed to the sole plate extends down through the disk (through an oversized hole in the disc) down into the masonry plate to prevent longitudinal and transverse movement. In multi directional applications, the sole plate is comprised of two plates. The sole plate is anchored to the superstructure with the bottom surface polished (typically stainless steel). Guide plates along the outside edge of the sole plate contain the sliding plate within the assembly. The top surface of the sliding plate contains a PTFE interface. The bottom surface contains the fixed shear pin which extends down through the disk into the masonry plate. Other modifications can be made to disk bearings to allow for high rotation or to dampen large translational movements in case of earthquake events (this configuration will not be found in Wisconsin bridges as it is not considered within a seismic zone).

Element Level Inspection

This element encompasses those bearings that contain a hard plastic disk. The bearing assemblies may be fixed against horizontal movement, fitted with guide bars to prevent movement in one horizontal direction or floating to allow free horizontal movement depending on the application.

On the inspection report form, bearings are recorded in units of each. The correct method for calculating the total quantity is the sum of the bearing assemblies throughout the structure. Where multiple condition states exist within a unit of measure only the predominant defect in severity and extent is recorded. For a bearing, only one defect will be applied to each bearing assembly. Therefore it is the inspector's responsibility to determine the predominant defect for the entire assembly. The other defects located within the unit of measure shall be captured by the inspector under the element or appropriate defect notes. The sum of all of the reported condition states must equal the total quantity of the element. This will quantify the element's condition and help generate quantity/cost estimates for future remedial work.

Due to their limited height and oft confined working parts, disk bearings are often difficult to inspect. However, movement related items can be inspected. Maintenance inspection of disk bearings should include the following items:

- Looking for deteriorated or spalled concrete underneath the bearing joint. This may reduce the bearing area and increase bearing stress on the concrete. Concrete deterioration may also indicate the bearing is not handling lateral forces as intended.
- Looking for corrosion, pitting, or section loss on the components or bearing surfaces. Advanced corrosion can cause a bearing to resist intended movement and may reduce the cross-sectional area of the bearing devices.
- Looking and listening for signs of bearing looseness, such as visual movements or rattling under live loads, uplift, and loose or missing fasteners/welds.



- Checking for proper bearing alignment. Improper alignments suggest a failing bearing, excessive superstructure movement, or substructure settlement. One sign of improper alignment is a superstructure that is tight against the backwall of the abutment. There should also be no exposure of the shear piston or top surface of the sliding plate. Look for excessive overhang of the sole plate over the sliding plate. Improper alignment may allow the girder to slide off of the bearing plate on days of temperature extremes. The top plate and disk should normally line up between temperatures of 60 to 70 degrees Fahrenheit, although this could vary for any individual bridge.
- Taking expansion/contraction measurements on bearings that are improperly aligned. An example of the measurements to be taken is shown in Figure 2.4.6.4-1. Lateral movements should also be measured. The ambient temperature at which the expansion/contraction measurements are taken should be recorded as well.
- Taking rotation measurements on bearings that are improperly aligned. Follow the example describing pot bearing measurements, shown in Figure 2.4.6.4-1.
- Checking the bearing components for proper seating and alignment with one another.
- Looking for debris build up that would inhibit proper bearing operation.

Element Defects

Refer to Appendix A for Defect descriptions. The defects listed are unique to the element and element material (i.e. concrete, steel, timber, etc.).

- Corrosion (1000)
- Connection (1020)
- Movement (2210)
- Alignment (2220)
- Bulging, Splitting, or Tearing (2230)
- Loss of Bearing Area (2240)

Condition State Commentary

The defects and condition state definitions are based on the AASHTO Manual for Bridge Element Inspection.

Appendix A defines the Condition States for each individual defect. The defects are expounded on and critical areas are discussed to aid the inspector in determining the severity of a defect. The WisDOT Bridge Inspection Field Manual tabulates the element defects listed above and bases the Condition States on the progression of severity for each defect. The Condition States are comprised of general descriptions and uniquely colored to follow the severity the description represents.



- Condition State 1 Good Green
- Condition State 2 Fair Yellow
- Condition State 3 Poor Orange
- Condition State 4 Severe Red



2.4.8.6 Other Bearing (Element 316)

This element should be used when a bearing is found to not compare with the previously stated bearing elements.

This element should not be used to capture enclosed or concealed bearings. If the inspector does happen across enclosed or concealed bearings, no bearing element will be reported on the inspection report. It is the department's discretion that bearings that cannot be seen cannot be inspected and therefore should not be reported on the inspection report.

Element Level Inspection

This element encompasses those bearings that cannot be classified under the bearing descriptions previously mentioned and regardless of permitted movements.

On the inspection report form, bearings are recorded in units of each. The correct method for calculating the total quantity is the sum of the bearing assemblies throughout the structure. Where multiple condition states exist within a unit of measure only the predominant defect in severity and extent is recorded. For a bearing, only one defect will be applied to each bearing assembly. Therefore it is the inspector's responsibility to determine the predominant defect for the entire assembly. The other defects located within the unit of measure shall be captured by the inspector under the element or appropriate defect notes. The sum of all of the reported condition states must equal the total quantity of the element. This will quantify the element's condition and help generate quantity/cost estimates for future remedial work.

When confronted with an Other Bearing, the inspector should approach the inspection as any other bearing visual inspection. Maintenance inspection of other bearings should include the following items:

- Looking for deteriorated or spalled concrete underneath the bearing joint. This may reduce the bearing area and increase bearing stress on the concrete. Concrete deterioration may also indicate the bearing is not handling lateral forces as intended.
- Looking for wear or binding on guide bars. Guide bars are sometimes used on expansion pot bearings to restrict lateral movements in the transverse direction.
- Checking for proper bearing alignment. Improper alignments suggest a failing bearing, excessive superstructure movement or substructure settlement. One sign of improper alignment is a superstructure that is tight against the backwall of the abutment. There should also be no exposure of the shear piston or top surface of the sliding plate. Look for excessive overhang of the sole plate over the sliding plate. Improper alignment may allow the girder to slide off of the bearing plate on days of temperature extremes. The top plate and disk should normally line up between temperatures of 60 to 70 degrees Fahrenheit, although this could vary for any individual bridge.
- Taking expansion/contraction measurements on bearings that are improperly aligned. An example of the measurements to be taken is shown in Figure 2.4.8.4-1. Lateral movements should also be measured. The ambient temperature at which the expansion/contraction measurements are taken should be recorded as well.



- Taking rotation measurements on bearings that are improperly aligned. An example of the measurements to be taken is shown in Figure 2.4.8.4-1.
- Checking the bearing components for proper seating and alignment with one another.
- Looking for debris build up that would inhibit proper bearing operation.
- Looking for any cracked welds.

Element Defects

Refer to Appendix A for Defect descriptions. The defects listed are unique to the element and element material (i.e. concrete, steel, timber, etc.).

- Corrosion (1000)
- Connection (1020)
- Movement (2210)
- Alignment (2220)
- Bulging, Splitting, or Tearing (2230)
- Loss of Bearing Area (2240)

Condition State Commentary

The defects and condition state definitions are based on the AASHTO Manual for Bridge Element Inspection.

Appendix A defines the Condition States for each individual defect. The defects are expounded on and critical areas are discussed to aid the inspector in determining the severity of a defect. The WisDOT Bridge Inspection Field Manual tabulates the element defects listed above and bases the Condition States on the progression of severity for each defect. The Condition States are comprised of general descriptions and uniquely colored to follow the severity the description represents.

- Condition State 1 Good Green
- Condition State 2 Fair Yellow
- Condition State 3 Poor Orange
- Condition State 4 Severe Red



2.4.9 Superstructure NBI Condition Ratings

Part of every Routine Inspection is rating the superstructure according to the Federal Highway Administration (FHWA) General Condition Rating Guidelines. The numeric condition ratings of these guidelines describe existing bridge components as compared to their as-built condition. Ratings range from 9 to 0, with 9 describing components in excellent condition, and 0 describing failed components.

Because only a single number is used to rate the superstructure, the rating must characterize its overall general condition. The rating should not be used to describe local areas of deterioration, such as isolated heavy corrosion or a bent flange due to a traffic impact. However, widespread heavy corrosion or widespread cracked welds would certainly influence the rating. A proper rating will therefore consider deterioration severity plus the extent to which it is distributed throughout the superstructure.

National Bridge Inventory (NBI) ratings are used to evaluate the state of deterioration of the superstructure material. Since material condition is independent of a bridge's design load-carrying capacity, postings or original design capacities less than current legal loads will not influence the rating. Similarly, temporary superstructure support does not change or improve the condition of the superstructure material. Temporary strengthening methods will therefore not influence the superstructure rating.

Decks that are built integral with the superstructure (steel or concrete box girders, decks of reinforced concrete tee beam bridges, etc.) are rated as separate components from the superstructure. In other words, since the superstructure is not part of the deck, the superstructure NBI rating should not influence the deck NBI rating. However, since integral decks form part of the superstructure's cross-section, deck deterioration is essentially the same as superstructure deterioration. Because of this, the superstructure on integral deck bridges should never receive a higher NBI rating than the deck.

On slab bridges, the deck is the same structural component as the superstructure. The FHWA Guidelines specifically state that ratings of decks built integral with superstructures (including slabs) should not be influenced by the superstructure rating. However, since the deck NBI rating accounts for inspection findings on both the top and underside, NBI condition ratings for the deck and superstructure must be the same.

The NBI general condition ratings found in the FHWA guidelines apply to decks, superstructures, and substructures. Rating 9 to 6 apply to components built of any material, while ratings 5 to 0 mention specific defects or deterioration that can be applied to certain materials. Because the NBI general condition ratings apply to a wide range of components and materials, Wisconsin has developed supplemental rating guidelines. These supplemental rating guidelines are used to assist the inspector in properly assigning condition ratings to specific components constructed of the most commonly used materials. The general condition ratings, along with the Wisconsin supplemental rating guidelines for superstructures, are as follows:



Code (Rating) Description

N NOT APPLICABLE

Wisconsin Supplemental Rating Guidelines:

Used for culverts only.

9 EXCELLENT CONDITION

Wisconsin Supplemental Rating Guidelines:

Concrete Superstructure – new condition.

Prestressed Concrete Superstructure – new condition.

Steel Superstructure – excellent condition.

Timber Superstructure – excellent condition.

8 VERY GOOD CONDITION – no problems noted.

Wisconsin Supplemental Rating Guidelines:

Concrete Superstructure – there are no noteworthy deficiencies which affect the structural capacity of the members.

Prestressed Concrete Superstructure – no problems noted.

Steel Superstructure – there are no noticeable or noteworthy deficiencies which affect the condition of the superstructure.

Timber Superstructure – there are no noteworthy deficiencies which affect the structural capacity of the members.

7 GOOD CONDITION – some minor problems.

Wisconsin Supplemental Rating Guidelines:

Concrete Superstructure – some minor problems. Non-structural hairline cracks without disintegration may be evident. Load-carrying capacity of structural members unaffected.

Prestressed Concrete Superstructure – non-structural cracks less than 1/64 inch (hairline crack) in width may be evident. No rust stains apparent.



Steel Superstructure – some rust may be evident without any section loss.

Timber Superstructure – minor decay, cracking or splitting of beams or stringers at non-critical locations.

- 6 **SATISFACTORY CONDITION** – structural elements show some minor deterioration.

Wisconsin Supplemental Rating Guidelines:

Concrete Superstructure – structural members show some minor deterioration or collision damage. Hairline structural cracks or spalls may be present with evidence of efflorescence. Minor water saturation marks. Generally, the reinforcing steel is unaffected.

Prestressed Concrete Superstructure – minor concrete damage or deterioration. Non-structural cracks are over 0.015 inch. Isolated and minor exposure of mild steel reinforcement may be present.

Steel Superstructure – rusting evident but with minor section loss (minor pitting, scaling or flaking) in critical areas.

Timber Superstructure – some decay, cracking or splitting of beams or stringers. Fire damage limited to surface scorching with no measurable section loss.

- 5 **FAIR CONDITION** – all primary structural elements are sound but may have minor section loss, cracking, spalling or scour.

Wisconsin Supplemental Rating Guidelines:

Concrete Superstructure – structural members are generally sound (structural capacity unaffected) but may have evidence of deterioration or disintegration. Numerous hairline structural cracks or spalls may be present with minor section loss of reinforcing steel possible.

Prestressed Concrete Superstructure – isolated and minor exposure of prestressing strands may be present. There may be structural cracks with little or no rust staining. Primary members are sound, but may be cracked or spalled.

Steel Superstructure – there is minor section loss in critical areas. Fatigue or out of plane distortion cracks may be present in non-critical areas. Hinges may be showing minor corrosion problems.



Timber Superstructure – moderate decay, cracking, splitting or minor crushing of beams or stringers. Fire damage limited to surface charring with minor, measurable section loss.

- 4 **POOR CONDITION** – advanced section loss, deterioration, spalling or scour.

Wisconsin Supplemental Rating Guidelines:

Concrete Superstructure – there is extensive disintegration. There are measurable structural cracks or large spall areas. Corroded reinforcing steel evident with measurable section loss. Structural capacity of some members may be diminished.

Prestressed Concrete Superstructure – moderate damage or deterioration to concrete portions of the member exposing reinforcing bars or prestressing strands. There is possible bond loss. Structural cracks with medium to heavy rust staining may be present. There may be a loss of camber.

Steel Superstructure – significant (measurable) section loss in critical areas. Fatigue or out of plane distortion cracks may be present in critical areas. Hinges may be frozen from corrosion. Load-carrying capacity of structural members affected.

Timber Superstructure – extensive decay, cracking, splitting or crushing of beams or stringers or significant fire damage. Diminished load-carrying capacity of members is evident.

- 3 **SERIOUS CONDITION** – loss of section, deterioration, spalling or scour have seriously affected primary structural components. Local failures are possible. Fatigue cracks in steel or shear cracks in concrete may be present.

Wisconsin Supplemental Rating Guidelines:

Concrete Superstructure – there is severe deterioration and/or disintegration of primary concrete members. Large structural cracks may be evident. Reinforcing steel is exposed with advanced stages of corrosion. Local failures or loss of bond are possible.

Prestressed Concrete Superstructure – severe damage to concrete and reinforcing elements of the member. Severed prestressing strand(s) or strand(s) are visibly deformed. Major or total loss of concrete section in the bottom flange. Major loss of concrete section in the web, but not occurring at the same location as concrete section loss in the bottom flange. Horizontal misalignment or negative camber to the member. Unless closely



monitored it may be necessary to restrict or close the bridge until corrective action is taken.

Steel Superstructure – severe section loss or cracking in critical areas. Minor failures may have occurred. Significant weakening of primary members evident.

Timber Superstructure – severe decay, cracking, splitting or crushing of beams or stringers or major fire damage. Load-carrying capacity is substantially reduced. Local failure may be evident.

- 2 **CRITICAL CONDITION** – advanced deterioration of primary structural elements. Fatigue cracks in steel or shear cracks in concrete may be present or scour may have removed substructure support. Unless closely monitored it may be necessary to close the bridge until corrective action is taken.

Wisconsin Supplemental Rating Guidelines:

Concrete Superstructure – advanced deterioration of primary concrete members. There is concrete disintegration around reinforcing steel with loss of bond. Some reinforcing steel may be ineffective due to corrosion or loss of bond. Numerous large structural cracks may be present. Localized failures of bearing areas may exist. Unless closely monitored, it may be necessary to close the bridge until corrective action is taken.

Prestressed Concrete Superstructure – critical damage to concrete and reinforcing elements of members. This damage may consist of one or more of the following:

1. Cracks which extend across the bottom flange and possibly into the web that are not closed below the surface damage (this indicates that the prestressing strands have exceeded yield strength).
2. An abrupt lateral offset as measured along the bottom flange or lateral distortion of exposed prestressing strands (this also indicates that the prestressing strands have exceeded yield strength).
3. Loss of prestress force to the extent that calculations show that repair cannot be made.
4. Excessive vertical misalignment.
5. Longitudinal cracks at the interface of the web and top flange that are not substantially closed below the surface damage (this indicates permanent deformation of the stirrups).

Steel Superstructure – severe section loss in many areas with holes rusted through at numerous locations in critical areas.



Timber Superstructure – severe decay, cracking, splitting or crushing of beams or stringers or major fire damage have resulted in significant local failures. Unless closely monitored, it may be necessary to close the bridge until corrective action is taken.

- 1 **“IMMINENT” FAILURE CONDITION** – major deterioration or section loss present in critical structural components or obvious vertical or horizontal movement affecting structural stability. Bridge is closed to traffic but corrective action may put it back in light service.

Wisconsin Supplemental Rating Guidelines:

Concrete Superstructure – bridge is closed to traffic. There is major deterioration or section loss present on primary structural elements. Obvious vertical or horizontal movement is affecting the structure’s stability. Corrective action may put the bridge back in light service.

Prestressed Concrete Superstructure – critical damage requiring the replacement of a member. Bridge is closed to traffic, and installation of temporary falsework to safeguard the public and the bridge should be taken at the time of the inspection.

Steel Superstructure – bridge is closed. Corrective action may put it back in light service.

Timber Superstructure – bridge is closed. Corrective action may put it back in light service.

- 0 **FAILED CONDITION** – out of service, beyond corrective action.

Wisconsin Supplemental Rating Guidelines:

Concrete Superstructure – bridge is closed; out of service. It is beyond corrective action; replacement is necessary.

Prestressed Concrete Superstructure – bridge is closed and out of service.

Steel Superstructure – bridge is closed. Replacement is necessary.

Timber Superstructure – bridge is closed. Replacement is necessary.

One suggested method for establishing a superstructure rating is to identify phrases within the general condition/Wisconsin supplemental guideline language that describes a superstructure condition more severe than what actually exists. The correct rating number will be one number higher than the one describing the more severe condition.



For example, suppose a steel superstructure has a failed paint system resulting in extensive corrosion, but without measurable section loss in critical areas. Minor fatigue cracks were found at diaphragm connections, but they only occurred at a few locations. Condition rating 6 indicates that there is minor deterioration and that rust is present but with only minor section loss in critical areas. Condition rating 5 indicates that there is minor section loss on primary elements in critical areas and that fatigue or out of plane distortion cracks may be present in non-critical areas. Even though condition rating 5 describes the presence of fatigue or out-of-plane distortion cracks, it represents a more severe condition than is actually occurring on the superstructure. Cracks in the actual bridge do not generally occur throughout and therefore do not represent the superstructure as a whole. Therefore, a rating of 6 would be appropriate.

Another method to help narrow down the superstructure rating number is to group the numbers in more general categories. Ratings of 9 to 7 apply to superstructures in good condition, 6 to 5 suggest fair condition, 4 to 3 suggest poor condition, 2 suggests poor/critical condition, and 1 to 0 suggest critical condition. It is also important to note that there is a significant change from a superstructure in condition rating 5 (minor section loss, structural elements sound) to condition rating 4 (advanced section loss, advanced deterioration). A reduction in load-carrying capacity can be measured/calculated when a superstructure enters condition rating 4.