

GENERAL NOTES

1. USE STAINLESS STEEL U-BOLTS, WASHERS, AND NUTS.
2. USE CLIPS ON EVERY EXTRUDED PANEL JOINT PER SIGN PLATE A4-6.
3. USE ALUMINUM VERTICAL SIGN SUPPORT BEAMS HAVING A 5 INCH BEAM DEPTH AND WEIGHT OF 3.7 LBS PER FOOT.
4. U-BOLTS SHALL BE STAINLESS STEEL AND MANUFACTURED TO THE PROPER SIZE TO FIT THE CHORDS OF THE OVERHEAD SIGN STRUCTURE.
5. DIAMETER OF U-BOLTS SHALL BE AS SHOWN.
6. THE LENGTH OF THE ALUMINUM VERTICAL SIGN SUPPORT BEAMS SHALL BE THE SAME AS THE HEIGHT OF THE SIGN THEY ARE SUPPORTING. BEAM LENGTHS MAY BE LONGER FOR PROPER ATTACHMENT TO CHORDS.
7. MINIMUM NUMBER OF BRACKETS PER SIGN IS TWO. SEE DETAIL BELOW FOR SPACING OF ALUMINUM VERTICAL SIGN SUPPORTS
8. MATERIAL NOTES:
STAINLESS STEEL U-BOLTS AND LOCKWASHERS ASTM 304.
STAINLESS STEEL HEX NUTS ASTM A276.
ALUMINUM I-BEAMS ARE 6061-T6.
9. SLOTTED HOLES IN I-BEAMS ARE NOT ALLOWED

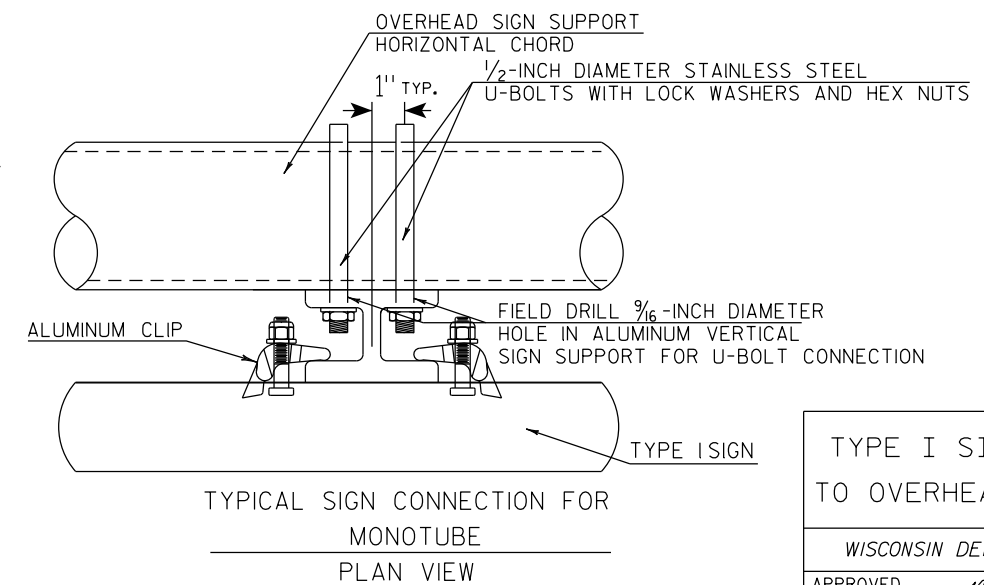
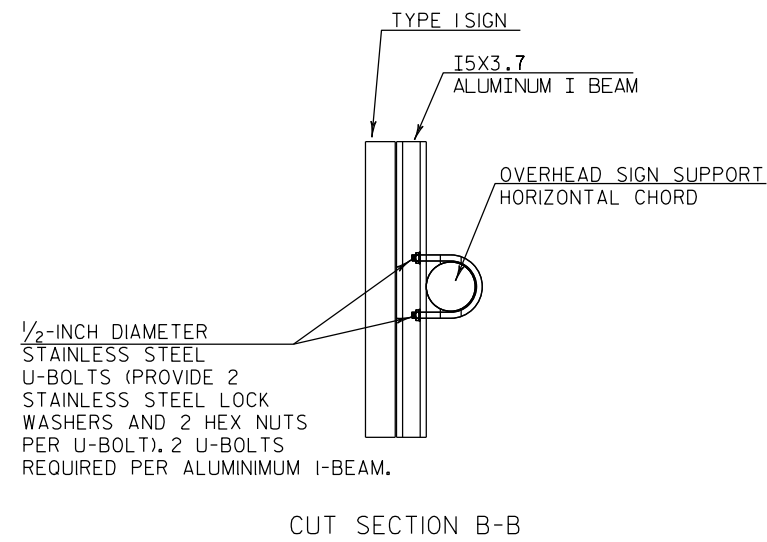
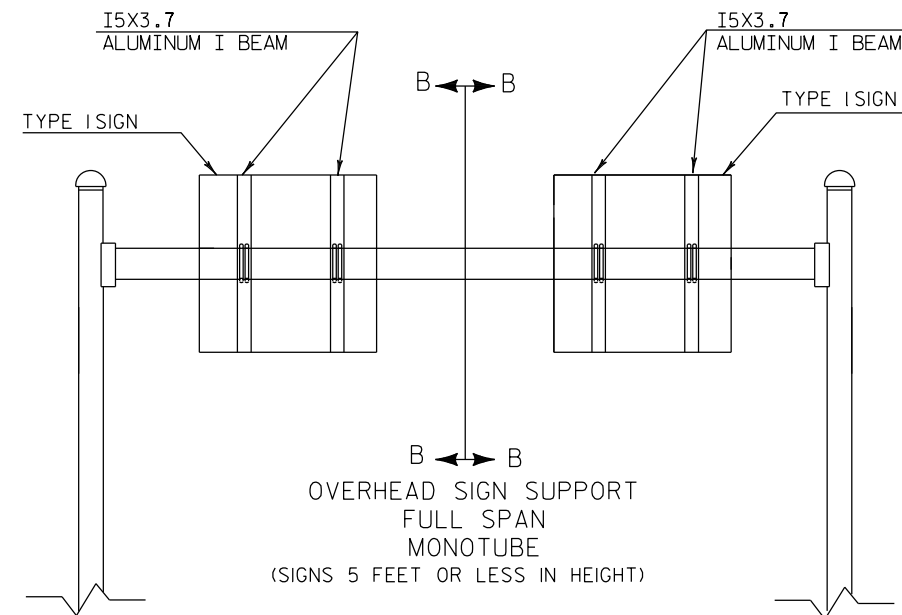
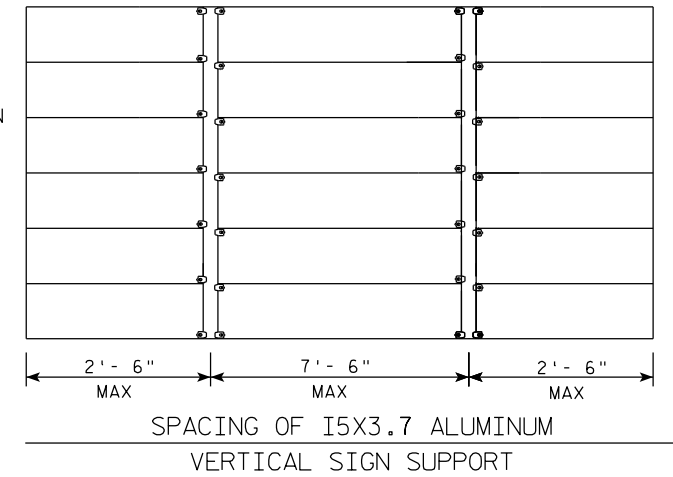
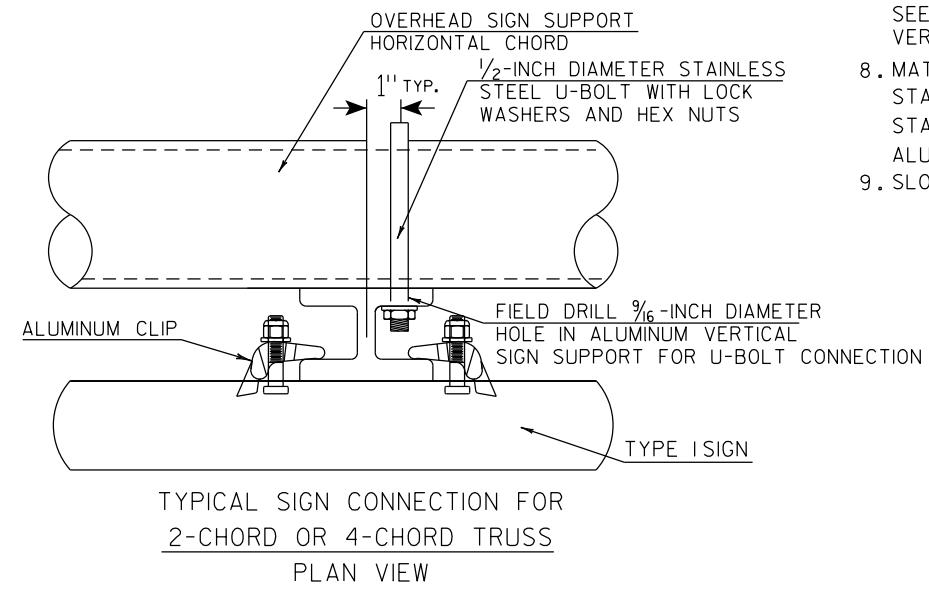
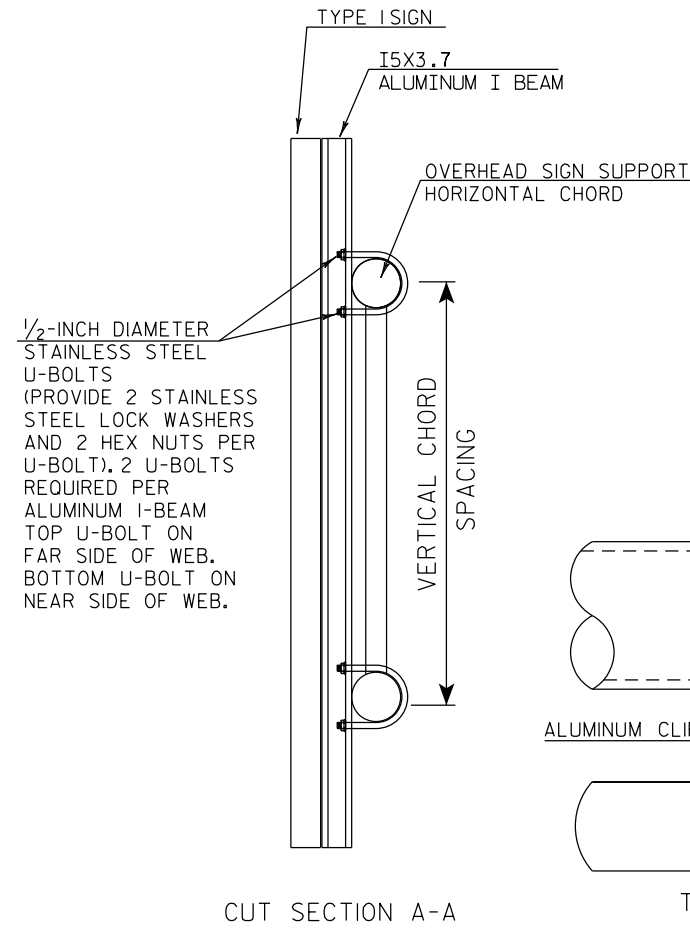
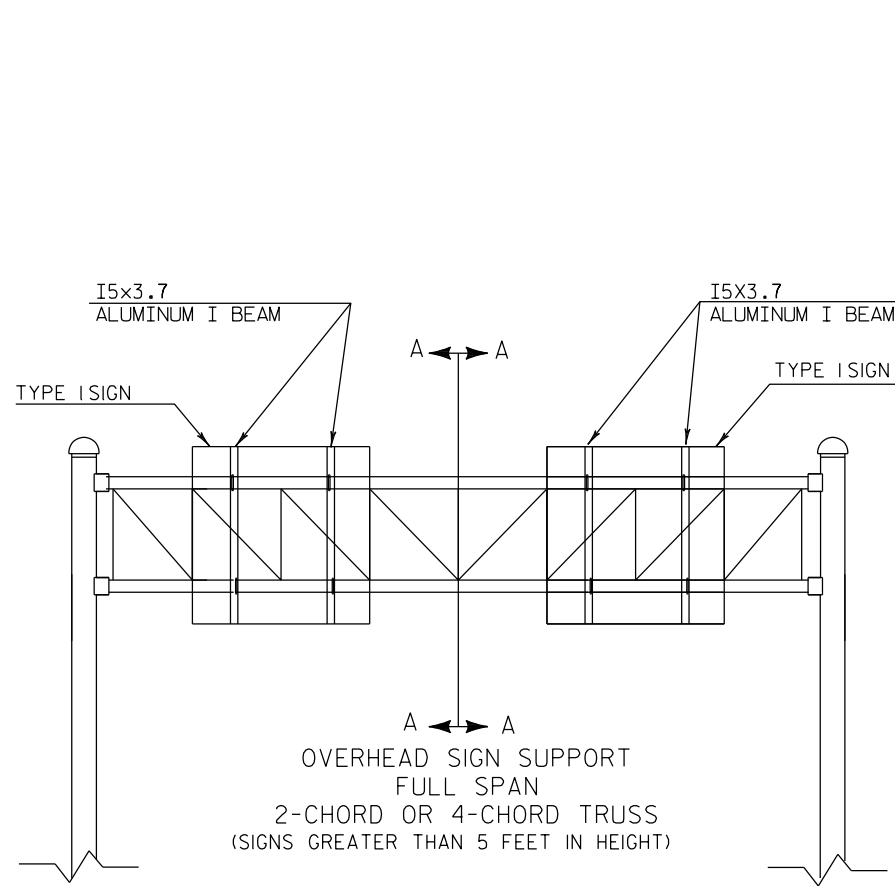

TYPE I SIGN CONNECTION TO OVERHEAD SIGN SUPPORT

WISCONSIN DEPT OF TRANSPORTATION

APPROVED *Matthew R. Rauch*
State Traffic Engineer

DATE 1/07/20 PLATE NO. A4-7A.1