

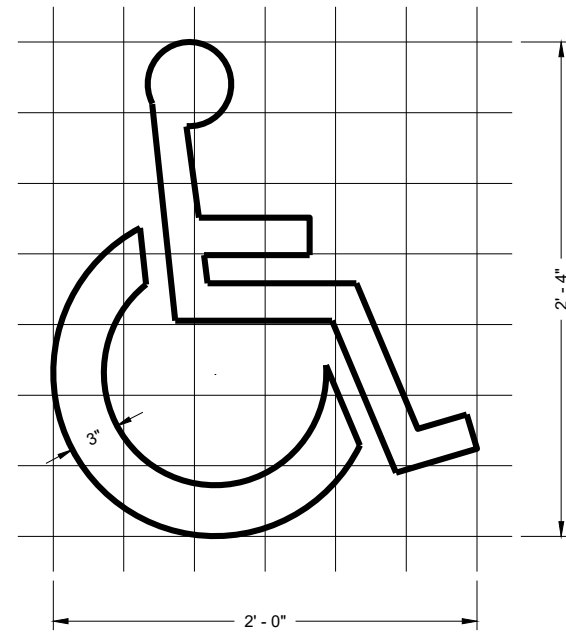

**GENERAL NOTES**

DETAILS OF INSTALLATION, MATERIALS AND WORKMANSHIP NOT SHOWN ON THIS DRAWING SHALL CONFORM TO THE PERTINENT REQUIREMENTS OF THE STANDARD SPECIFICATIONS AND APPLICABLE SPECIAL PROVISIONS.



**HANDICAP SYMBOL**

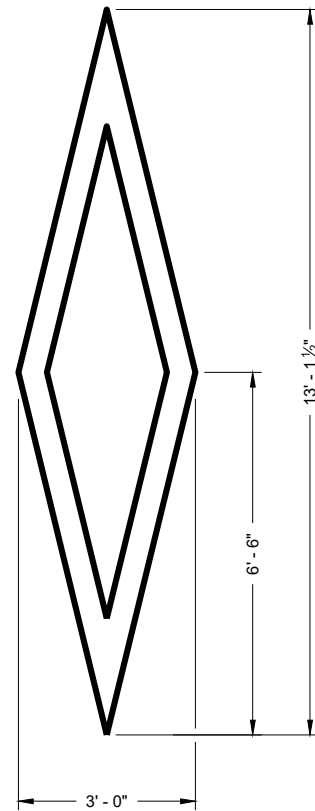

**PREFERENTIAL LANE SYMBOL**

6

6

SDD 15C07 - 15a

SDD 15C07 - 15a

**PAVEMENT MARKING SYMBOLS**

STATE OF WISCONSIN  
DEPARTMENT OF TRANSPORTATION

APPROVED  
November 2019 /S/ Matthew Rauch  
DATE STATE SIGNING AND MARKING  
ENGINEER

FHWA



# SDD 15C07-b Pavement Marking Words

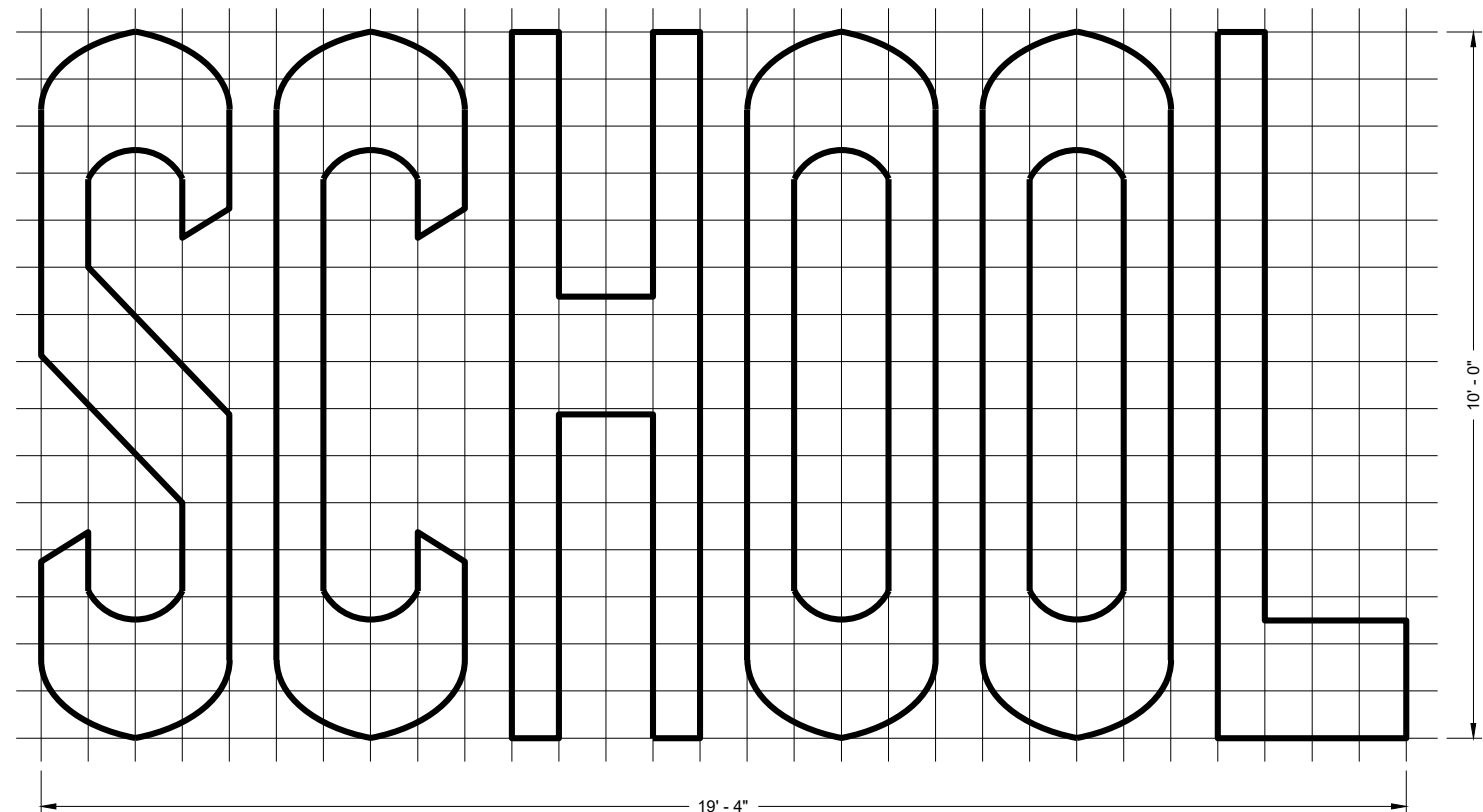
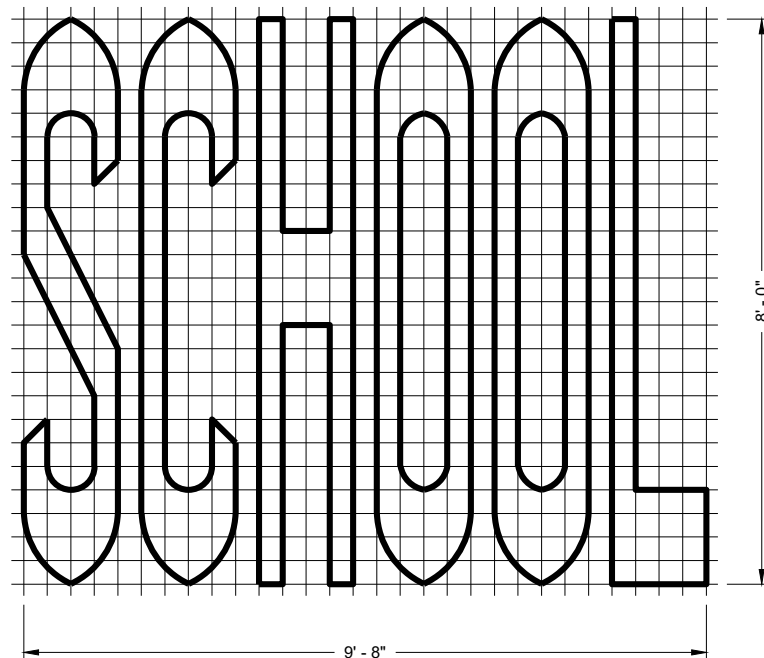
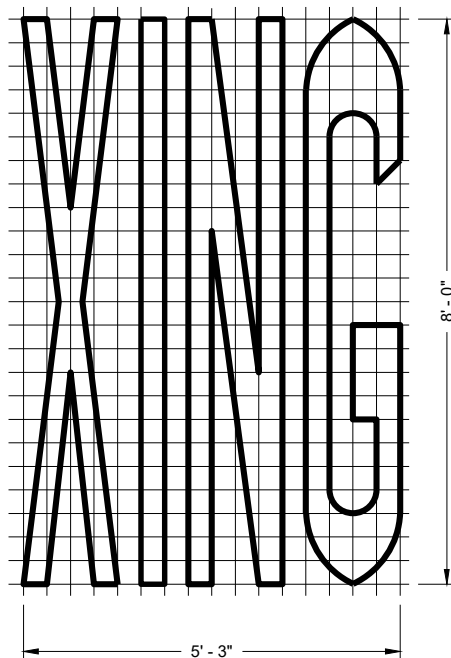
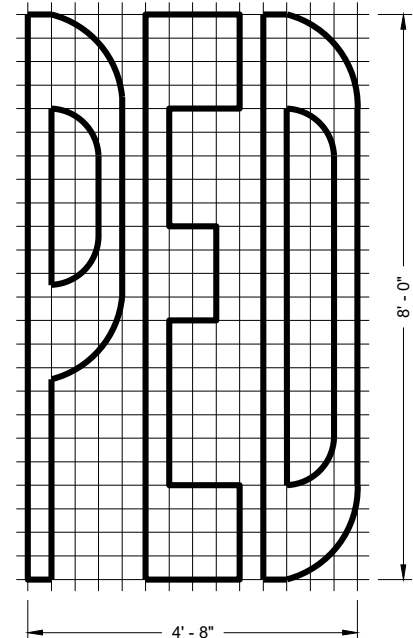
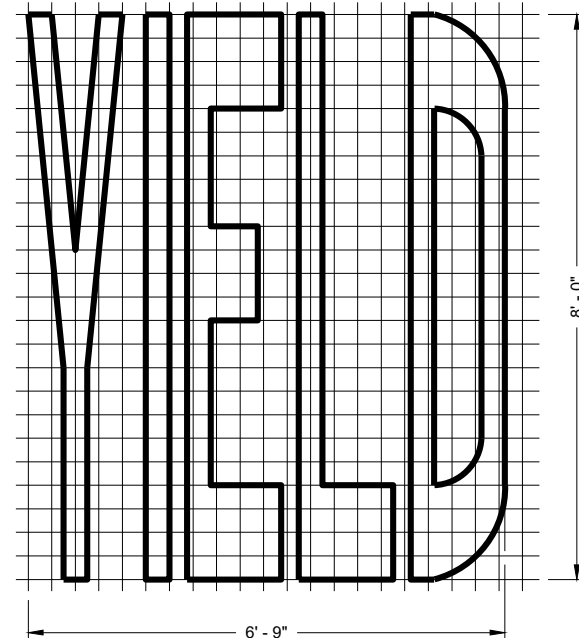
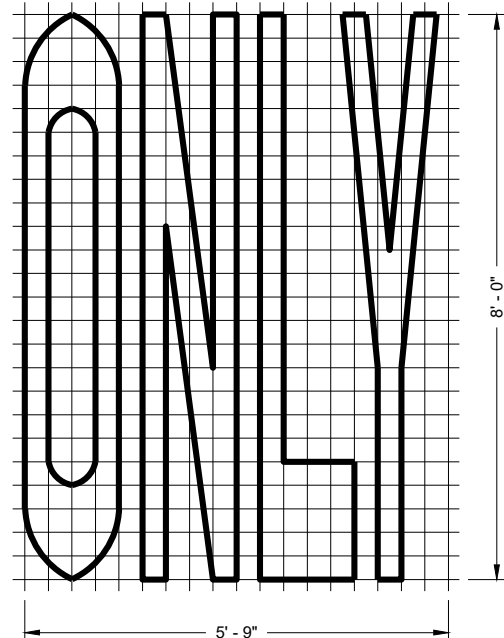
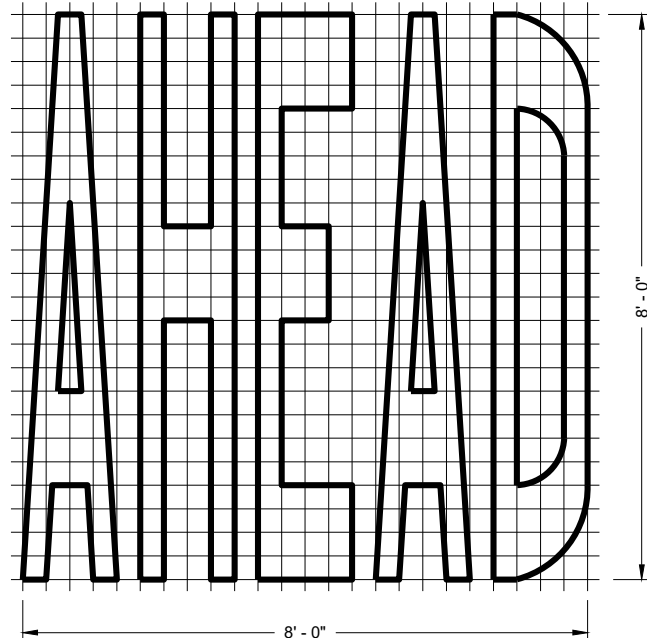
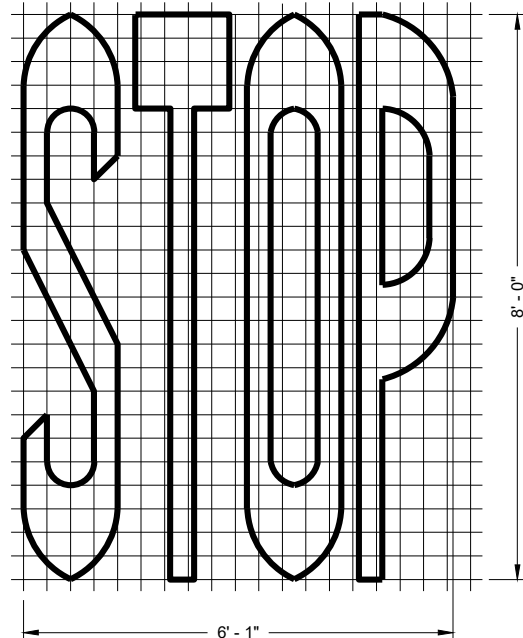

**SINGLE LANE**

**TWO - LANE**

### GENERAL NOTES

DETAILS OF INSTALLATION, MATERIALS AND WORKMANSHIP NOT SHOWN ON THIS DRAWING SHALL CONFORM TO THE PERTINENT REQUIREMENTS OF THE STANDARD SPECIFICATIONS AND APPLICABLE SPECIAL PROVISIONS.

### PAVEMENT MARKING WORDS

STATE OF WISCONSIN  
DEPARTMENT OF TRANSPORTATION

APPROVED  
November 2019 /S/ Matthew Rauch  
DATE STATE SIGNING AND MARKING  
ENGINEER

FHWA

SDD 15C07 - 15b

SDD 15C07 - 15b



# SDD 15C7-c Pavement Marking Arrows

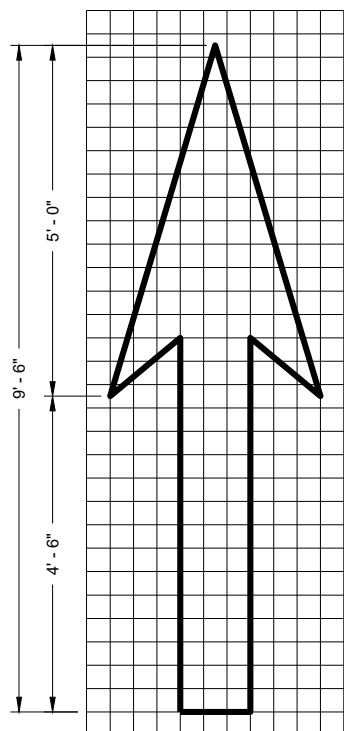

**TYPE 1**

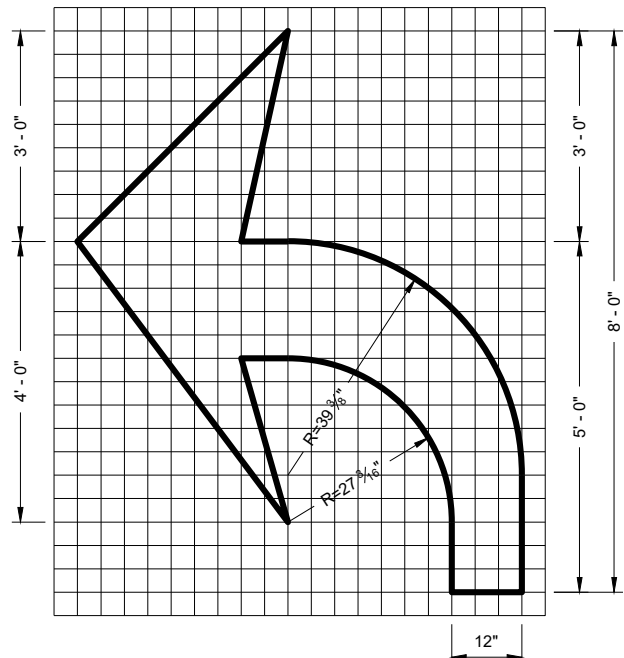

**TYPE 2**

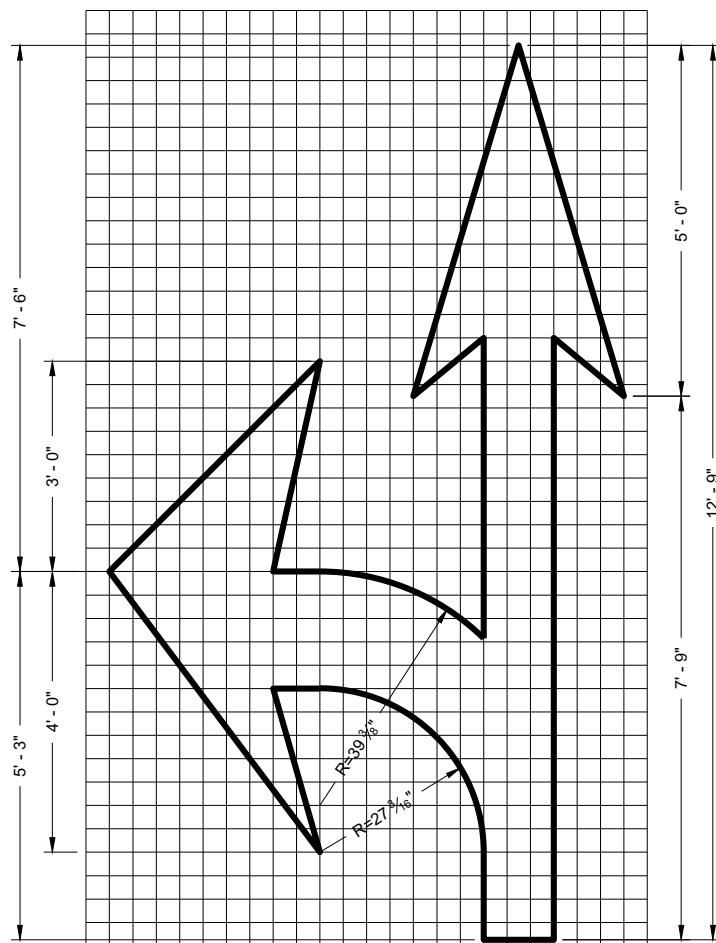

**TYPE 3**

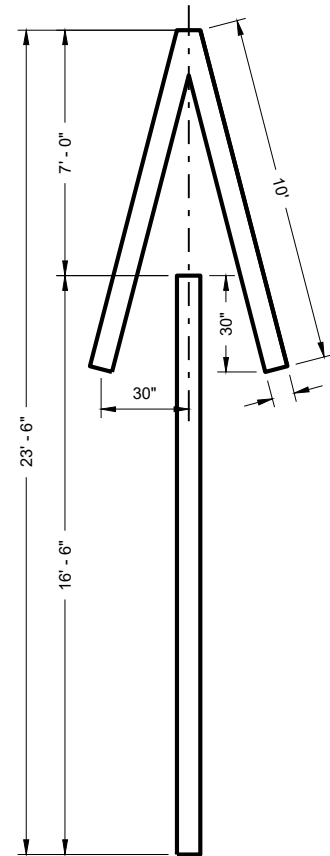

**TYPE 4**

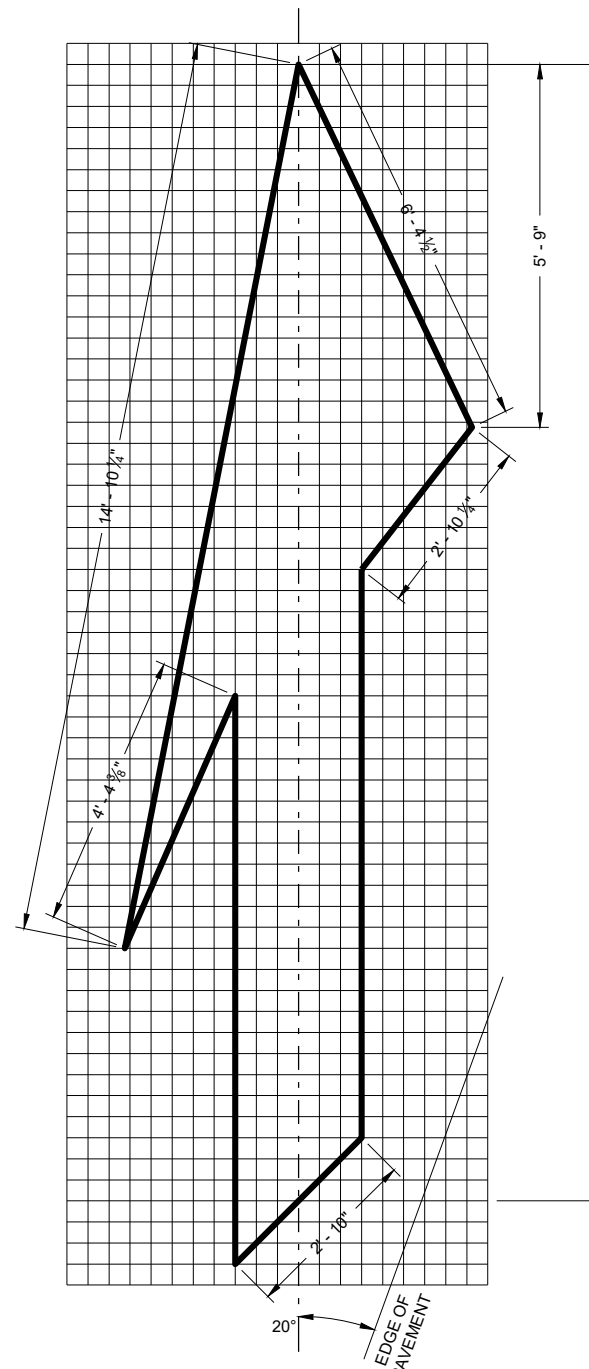

**TYPE 5 LANE DROP ARROW**

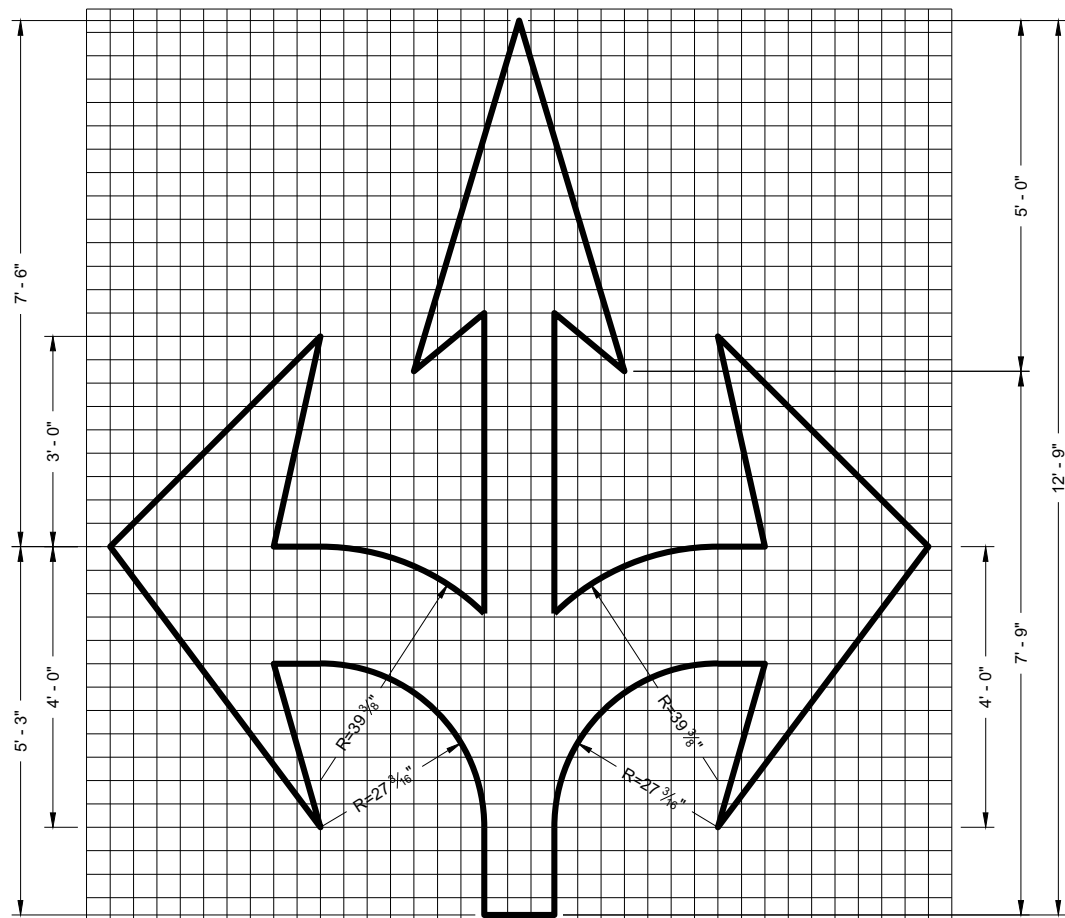

**TYPE 6**

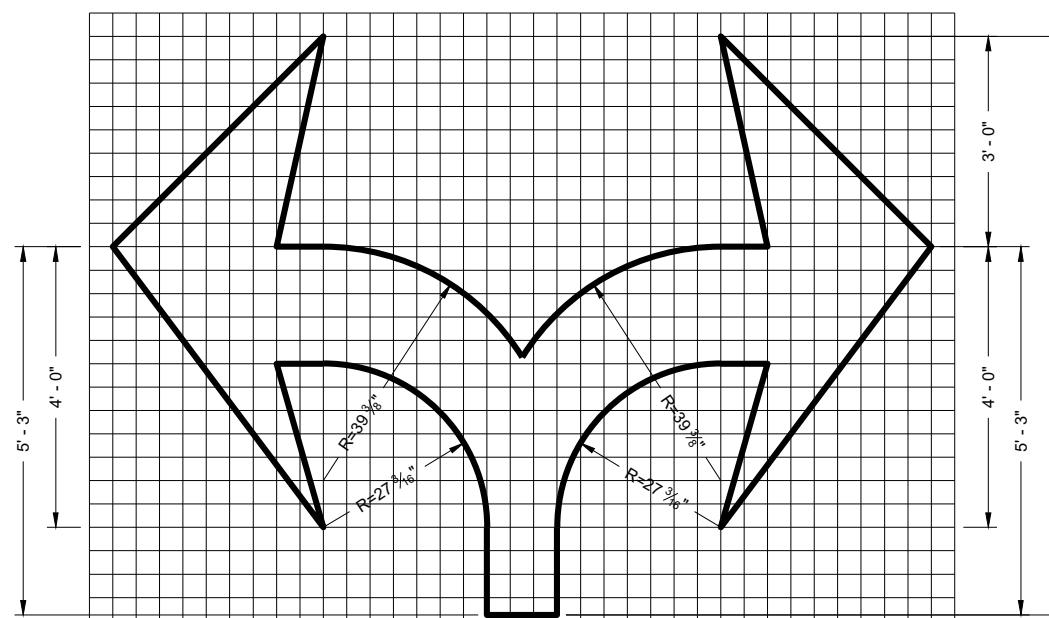

**TYPE 7**

## GENERAL NOTES

DETAILS OF INSTALLATION, MATERIALS AND WORKMANSHIP NOT SHOWN ON THIS DRAWING SHALL CONFORM TO THE PERTINENT REQUIREMENTS OF THE STANDARD SPECIFICATIONS AND APPLICABLE SPECIAL PROVISIONS.

6

SDD 15C07 - 15c

6

SDD 15C07 - 15c

### PAVEMENT MARKING ARROWS

STATE OF WISCONSIN  
DEPARTMENT OF TRANSPORTATION

APPROVED

November 2019

DATE

/s/ Matthew Rauch  
STATE SIGNING AND MARKING  
ENGINEER

FHWA

## GENERAL NOTES

DETAILS OF INSTALLATION, MATERIALS AND WORKMANSHIP NOT SHOWN ON THIS DRAWING SHALL CONFORM TO THE PERTINENT REQUIREMENTS OF THE STANDARD SPECIFICATIONS AND APPLICABLE SPECIAL PROVISIONS.

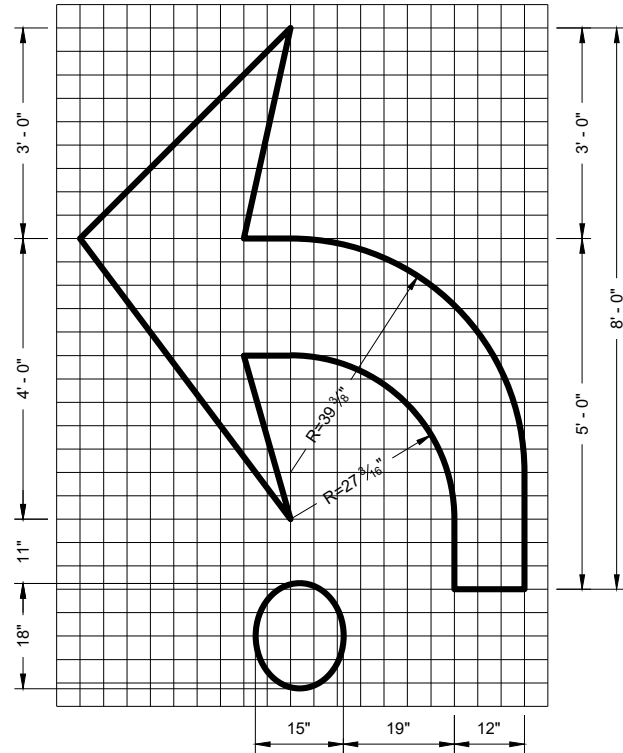

**TYPE 2R**

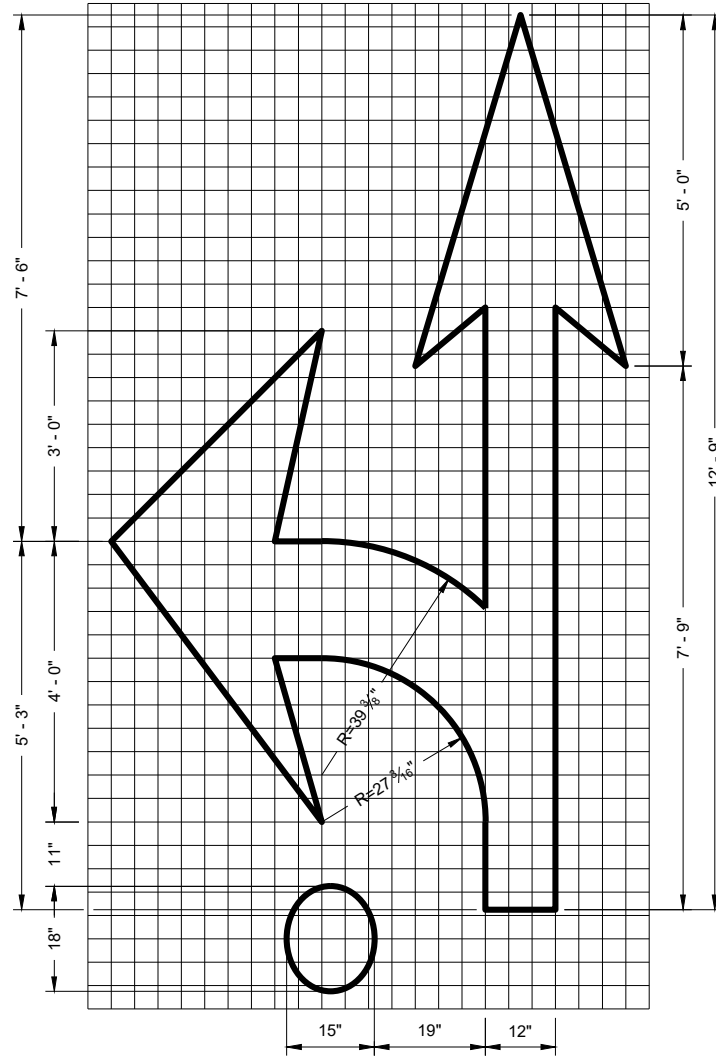

**TYPE 3R**

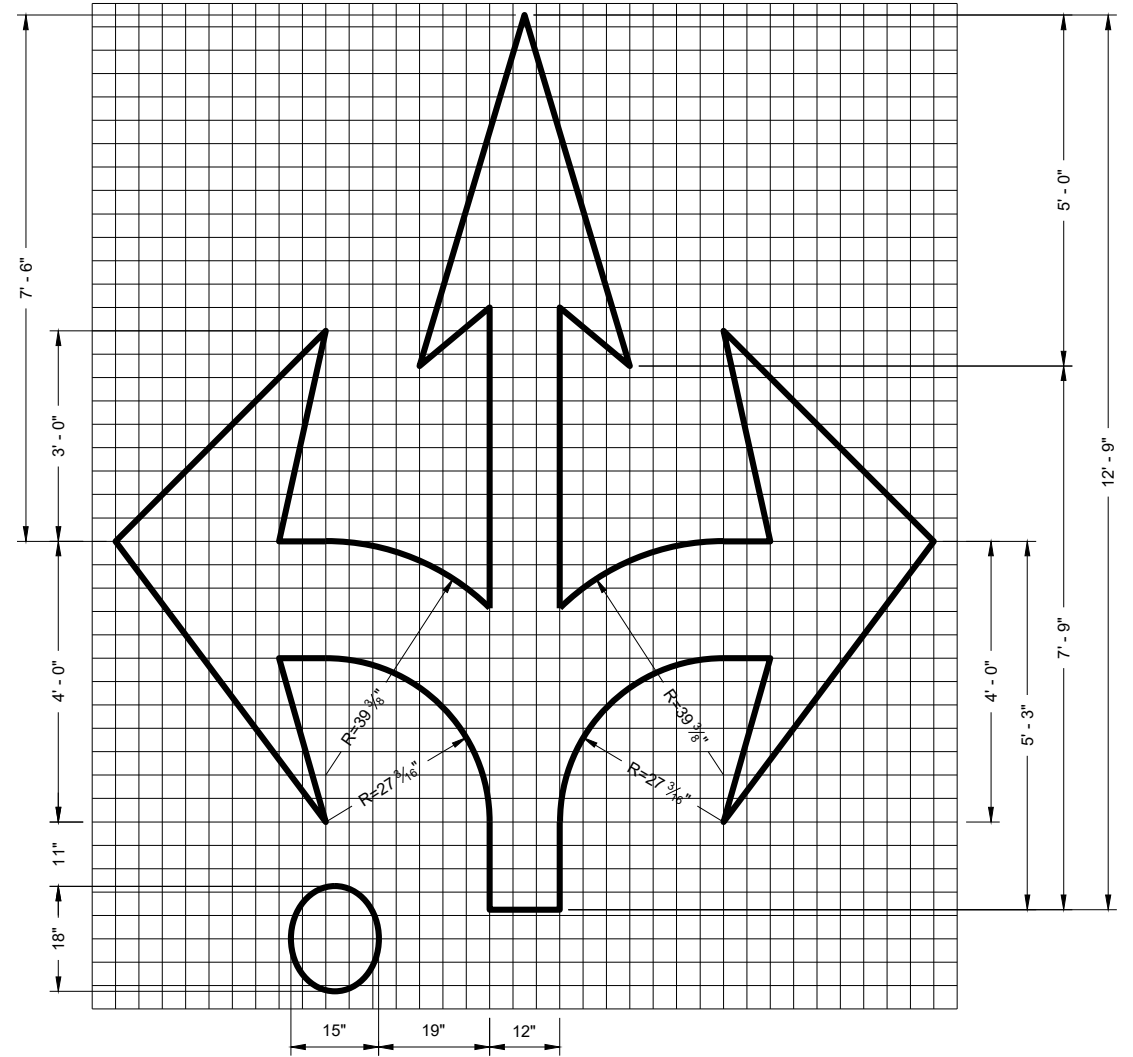

**TYPE 6R**

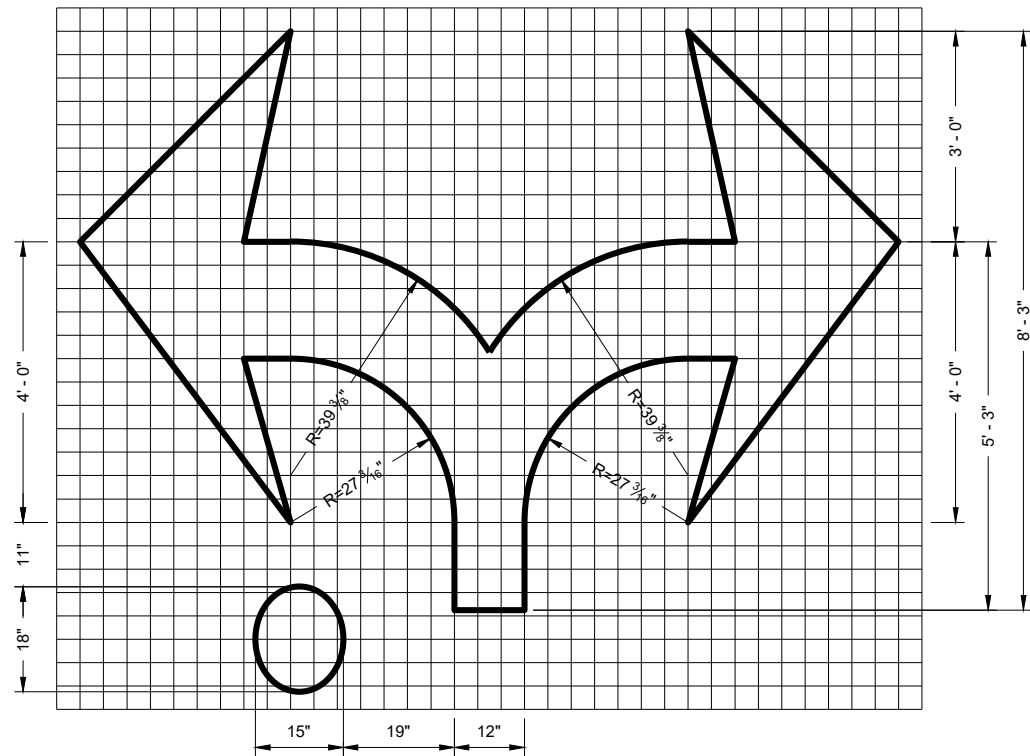

**TYPE 7R**

**ROUNDBOUT  
MARKING ARROWS**

STATE OF WISCONSIN  
DEPARTMENT OF TRANSPORTATION

APPROVED  
November 2019 /S/ Matthew Rauch  
DATE STATE SIGNING AND MARKING  
ENGINEER

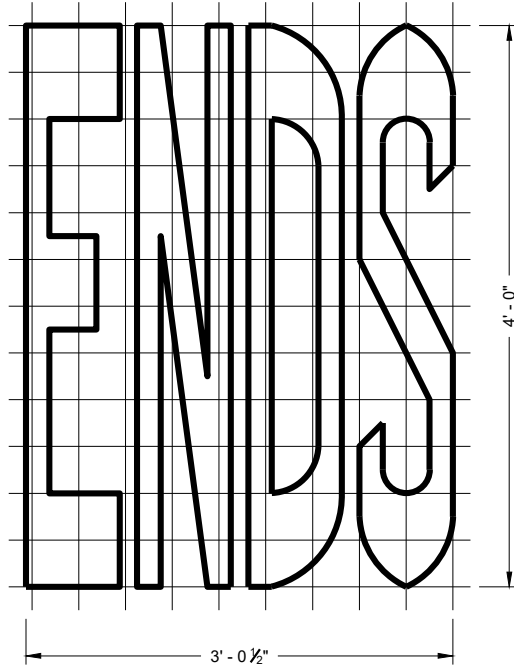
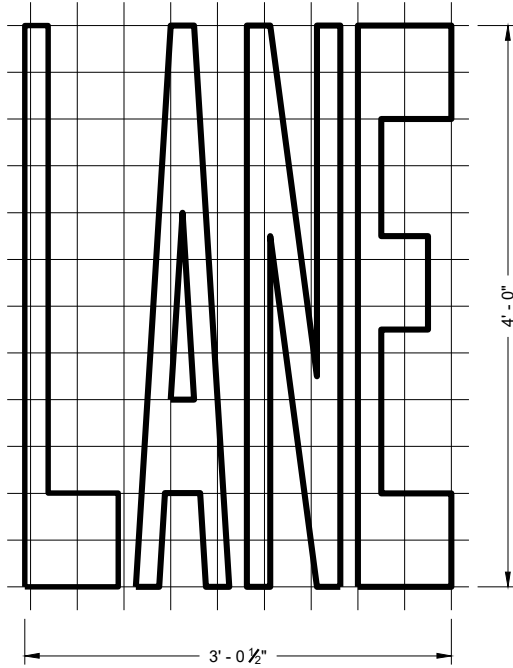
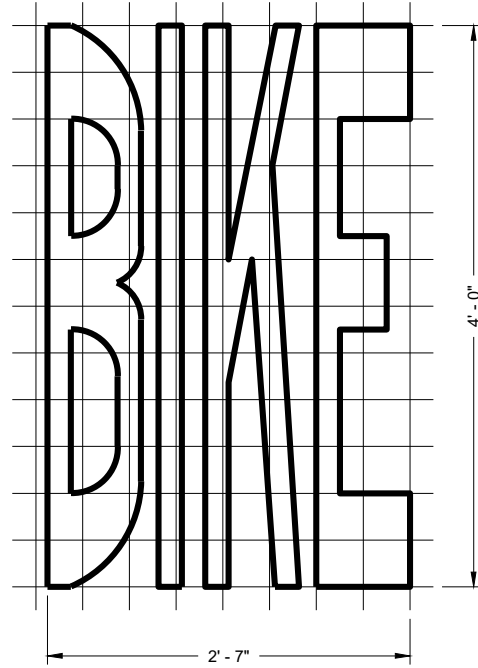

**BIKE LANE WORDS**

**GENERAL NOTES**

DETAILS OF INSTALLATION, MATERIALS AND WORKMANSHIP NOT SHOWN ON THIS DRAWING SHALL CONFORM TO THE PERTINENT REQUIREMENTS OF THE STANDARD SPECIFICATIONS AND APPLICABLE SPECIAL PROVISIONS.

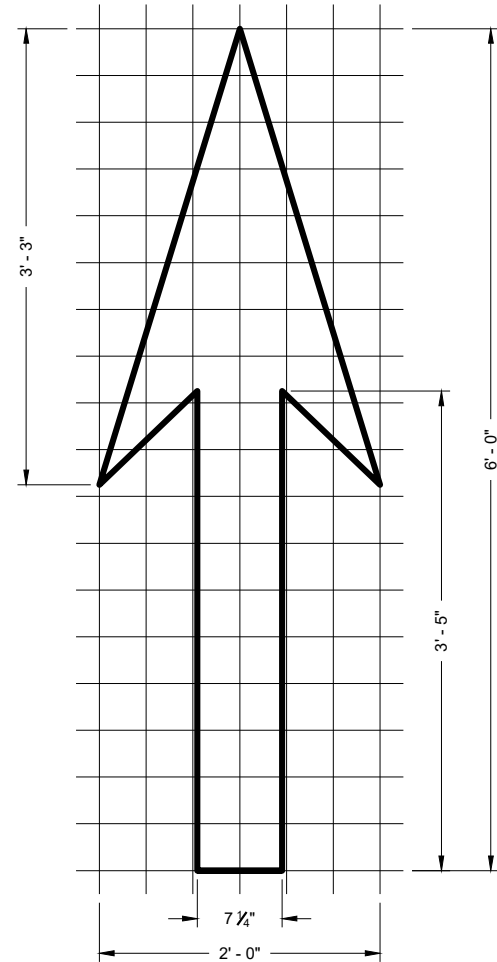
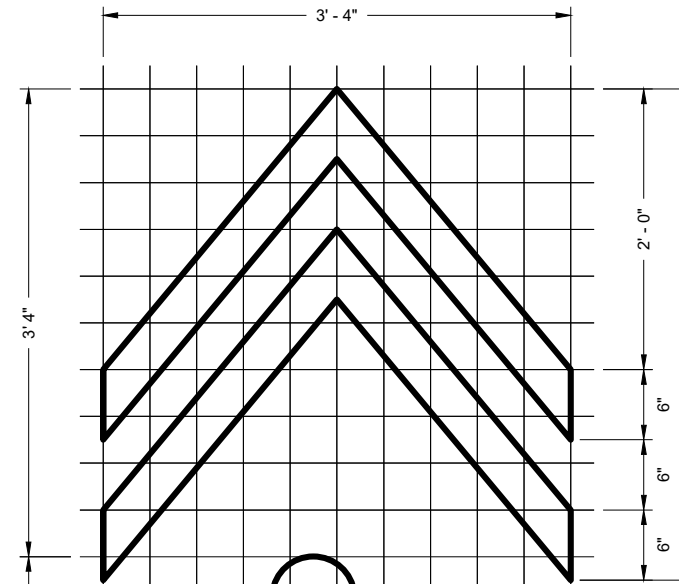

**BIKE LANE ARROW**

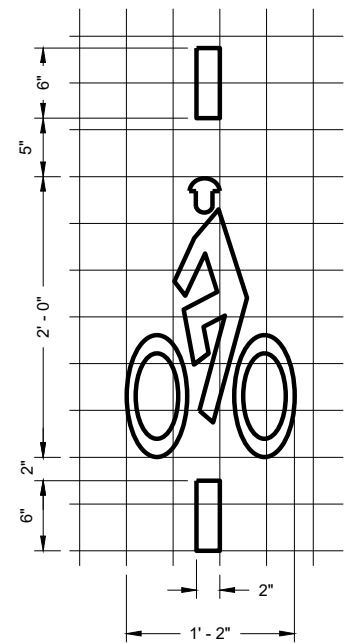

**BICYCLE DETECTOR PAVEMENT MARKING**

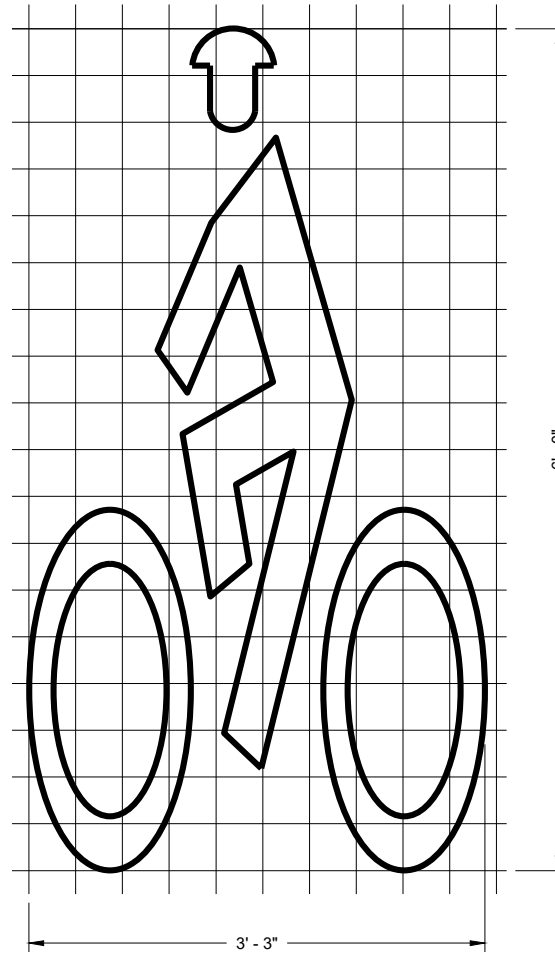

**BIKE LANE SYMBOL**

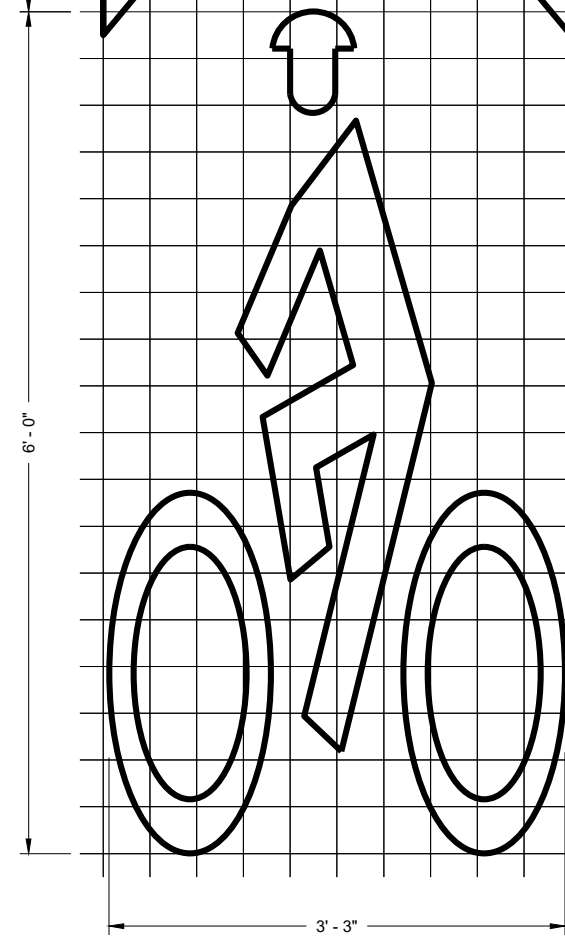

**BIKE LANE SYMBOL FOR SHARED LANE**

6

6

**PAVEMENT MARKING FOR BIKE LANES**

STATE OF WISCONSIN  
DEPARTMENT OF TRANSPORTATION

APPROVED  
November 2019 /S/ Matthew Rauch  
DATE STATE SIGNING AND MARKING  
ENGINEER

Pavement Marking Words, Symbols and Arrows

References:

Traffic Engineering, Operations and Safety Manual (TEOpS Chapter 3)
Manual on Uniform Traffic Control Devices, Section 9

Bid items associated with this drawing:

Table with 3 columns: ITEM NUMBER, DESCRIPTION, UNIT. Rows include Marking Arrows (material), Marking Words (material), and Marking Symbols (material), all with UNIT 'EACH'.

Standardized Special Provisions associated with this drawing:

Table with 2 columns: STSP NUMBER, TITLE. Row: NONE

Other SDDs associated with this drawing:

SDD 15C8 Pavement Marking, Mainline and Turn Lanes

Design Notes:

The bid item number used for words, symbols, and arrows depends upon the choice of material for the marking. See WisDOT Standard Specifications for Highway Structure Construction.
When bidding words, symbols, and arrows specify the kind of word, symbol, or arrow on the Miscellaneous Quantities list heading. There should be a list for every type of word, symbol, or arrow to be used.
The Pedestrian Word shall be used with the word "XING", place one set per lane.
Consult with the Regional Signing/Marking Engineer and Regional Bike and Ped Coordinator to determine the appropriate markings for bike accommodations.

Contact Person:

Jeannie Silver (608) 246-5408