

US 2 Belknap Street Truck Detour

June 2016

Construction years: 2017 and 2018

Multi-trip permitted oversize overweight vehicles are encouraged to take the detour. Single trip permitted oversize overweight vehicles may not fit on the detour. Drivers should contact the project contractor to arrange special accommodations for such vehicles.

Construction Zone Restriction		Detour Restriction	
Height	13.5'	Height	16'
Width	8.5'	Width	15'
Length	75'	Length	125'

Multi-trip vehicles were checked. The following vehicles **passed** through truck detour.

80' Mobile Home:

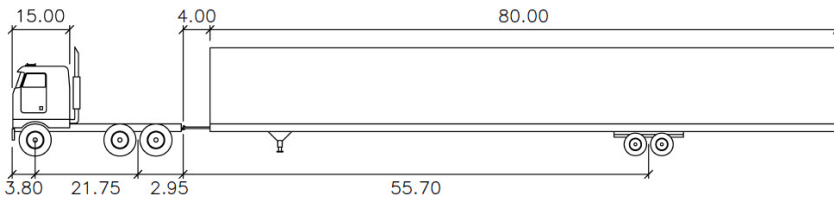

Length	112.50'
Width	14.17'

WB-92:

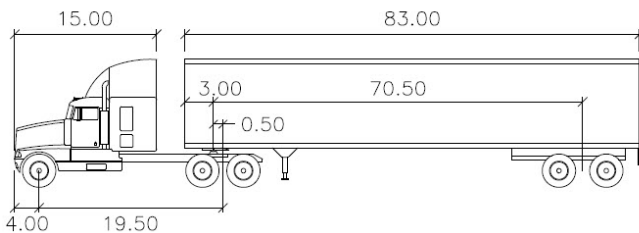

Length	103.50'
Width	8.50'

Combine:

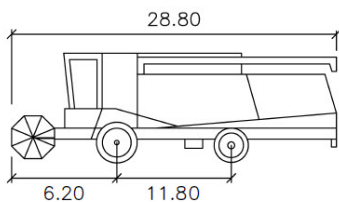

Length	33.50'
Width	20.0'



For additional information please visit:

<http://wisconsindot.gov/Pages/projects/by-region/nw/us2belknap/default.aspx>

US 2 Belknap Street Truck Detour

June 2016

Construction years: 2017 and 2018

Multi-trip permitted oversize overweight vehicles are encouraged to take the detour. Single trip permitted oversize overweight vehicles may not fit on the detour. Drivers should contact the project contractor to arrange special accommodations for such vehicles.

Single-trip vehicles were checked: The following vehicles **failed to pass** through truck detour.

DST Lowboy:

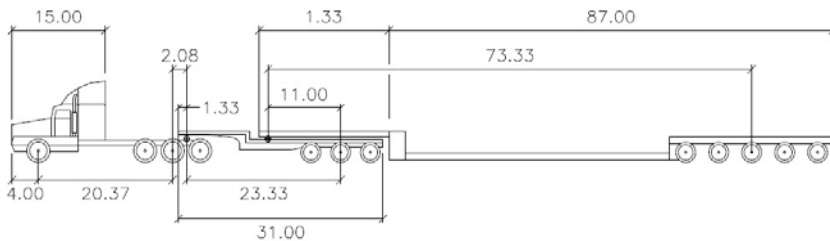

Length	124.40'
Width	12.50'

*5 axle lowboy failed due to encroachment onto curbs in multiple locations.

165' Beam:

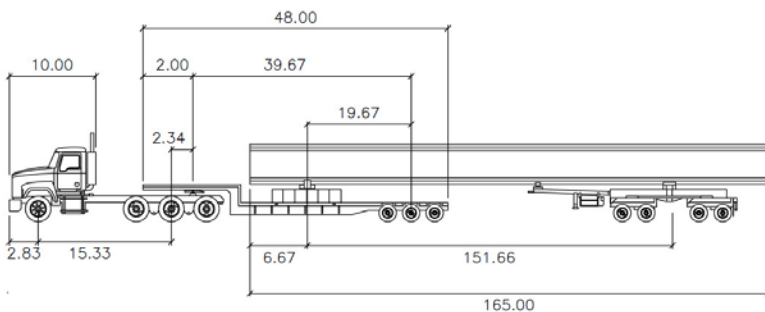

Length	201.10'
Width	8.50'

*165' beam failed due to length constraints at multiple intersections.



For additional information please visit:

<http://wisconsindot.gov/Pages/projects/by-region/nw/us2belknap/default.aspx>