

McFarland Area – Exchange Street to Larson Beach Road

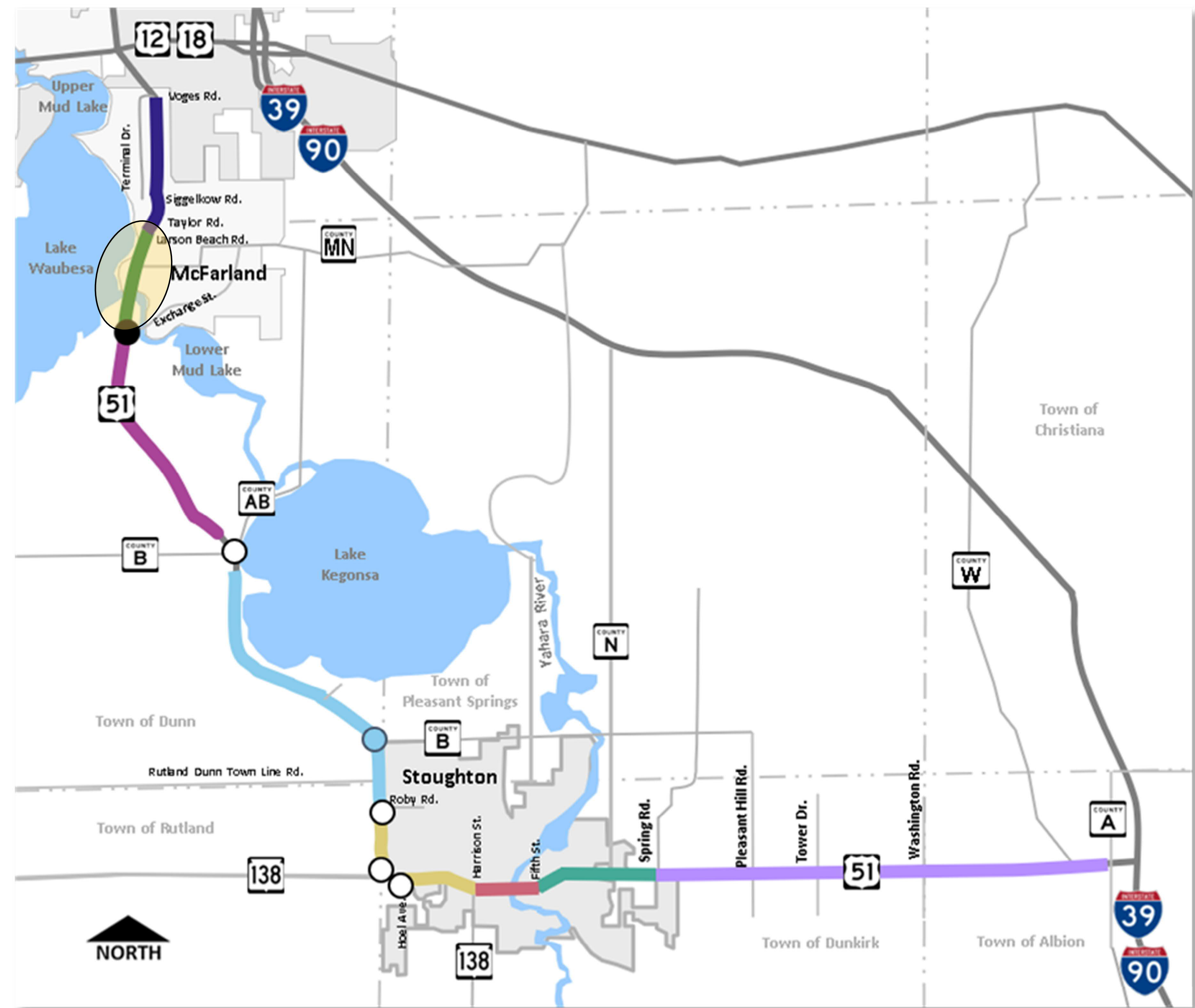

- Project highlights
 - Reconstruct existing 4-lane urban section
 - Intersection improvements
 - Replace the Yahara River bridge
 - Improve pedestrian accommodations
- Anticipated traffic control
 - Open to through traffic (bi-directional)
- Earliest anticipated construction year
 - 2026

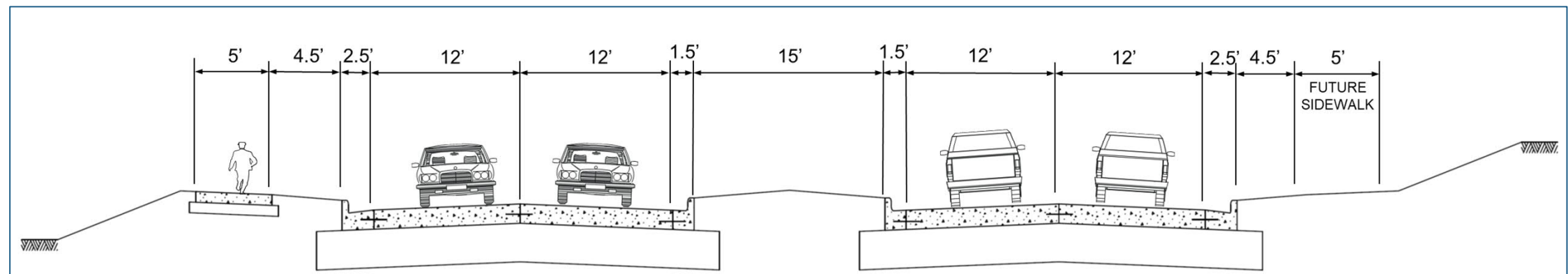

Proposed Typical Section:
Exchange Street to Yahara River Bridge

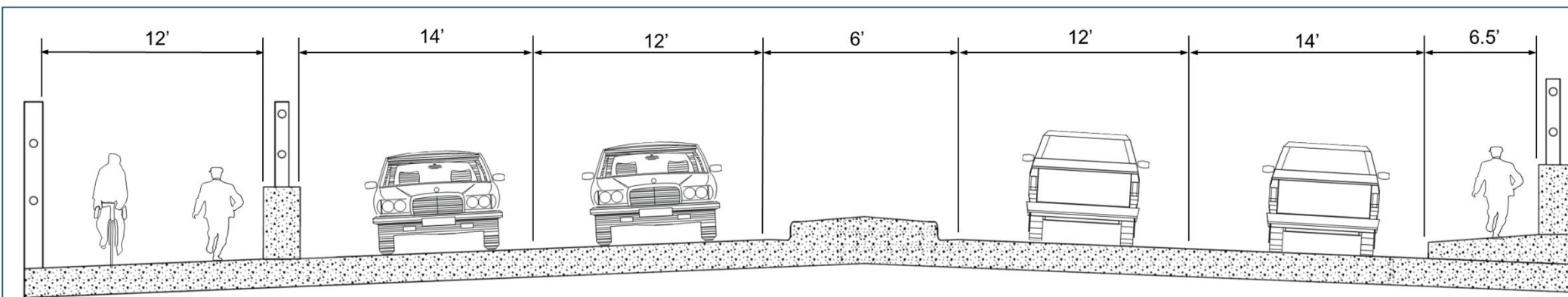

Proposed Typical Section:
Yahara River Bridge

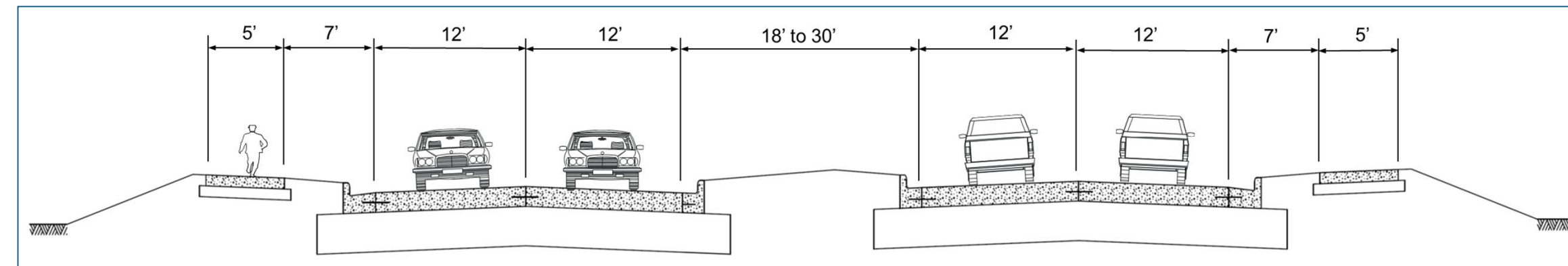

Proposed Typical Section:
Yahara River Bridge to Larson Beach Road

McFarland Area – Larson Beach Road to Voges Road

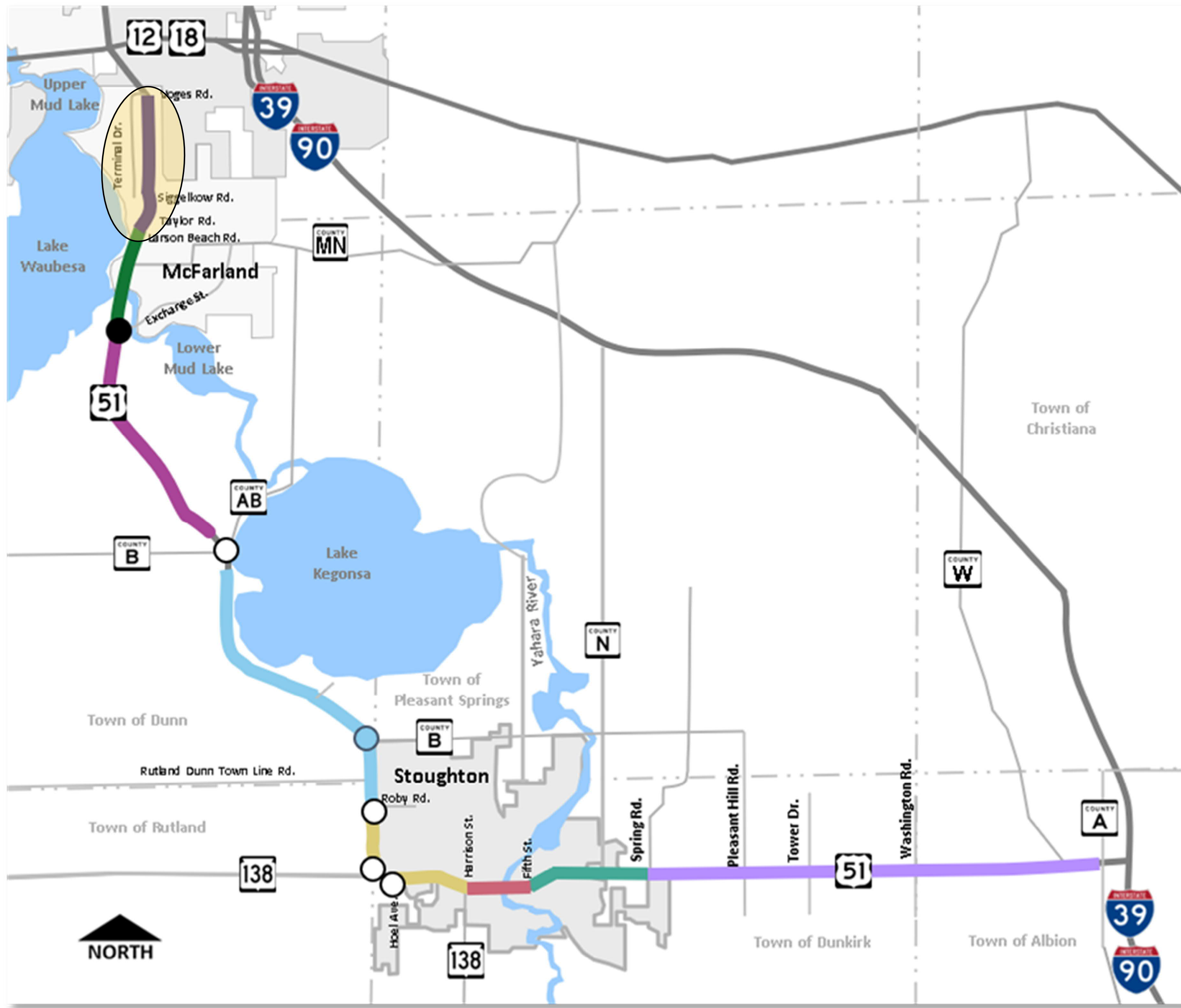

- Project highlights
 - Replace existing concrete pavement
 - Reconstruct southbound bridge over Taylor Road
 - Add auxiliary lane
- Anticipated traffic control
 - Open to through traffic (bi-directional)
- Earliest anticipated construction year
 - 2024

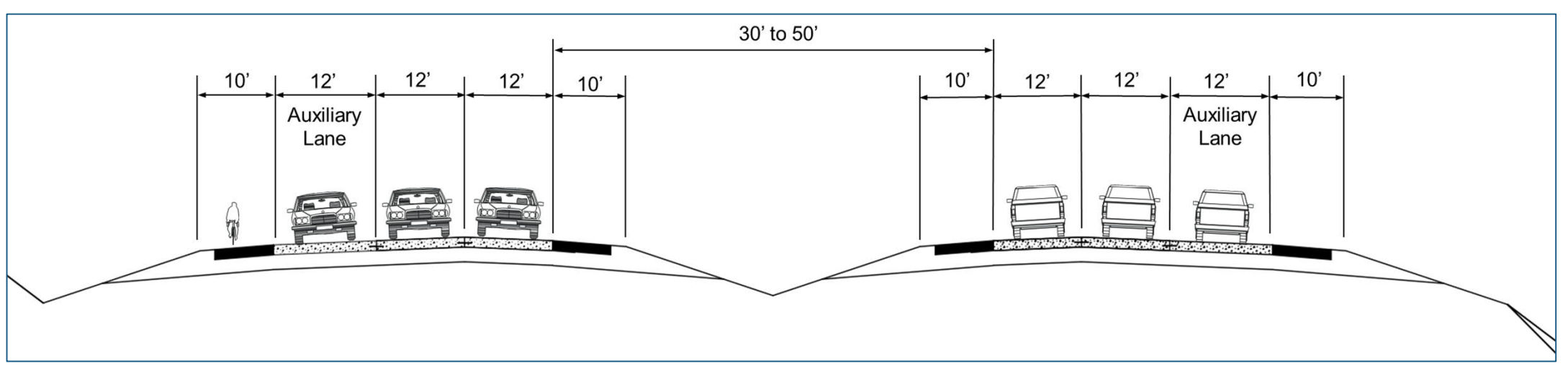

Proposed Typical Section