

# Public Involvement Meeting Handout

**WIS 69  
County D to Valley Road  
Dane County**

Project ID: 1693-05-02



**April 13<sup>th</sup>, 2016  
5:30pm**

**Montrose Town Hall  
1341 Diane Ave  
Belleville, WI 53508**

## Purpose of the meeting

The purpose of this meeting is to discuss and give a status update for the WIS 69 design project between County D in Belleville and Valley Road in Verona. As previously discussed, WisDOT is proposing to reconstruct the highway, adjusting both the vertical and horizontal alignment along with improving the horizontal cross section.

The pavement along WIS 69 has shown significant deterioration, and as a result an asphalt overlay was placed on the highway in the fall of 2014. This temporary fix to the roadway is only expected to last a few years, giving way to the proposed WIS 69 improvements being discussed today. This project will aim to provide a durable new pavement structure, reduce the crash rates, lessen crash severity, and improve the overall traffic flow throughout the system. WisDOT is requesting input from local agencies on this project to achieve the best final product possible.

## Project information

The project begins near the intersection of County D in Belleville, WI and extends north approximately 8.11 miles to the intersection of Valley Road. Proposed improvements include adjusting the horizontal and vertical alignment to current standards and laying 5-inches of Hot Mix Asphalt (HMA) over 12-inches of Base Aggregate Dense 1 1/4-inch. Subgrade improvements will consist of 12-inches of Select Crushed Material over Geogrid. The proposed typical section for WIS 69 consists of one 12-foot travel lane in each direction with 8-foot wide shoulders (5-foot paved) on both sides. Right-of-way acquisition is expected for horizontal alignment, cross section, intersection, and drainage improvements. Construction of the project is scheduled for 2020.

### Proposed Urban Cross Section

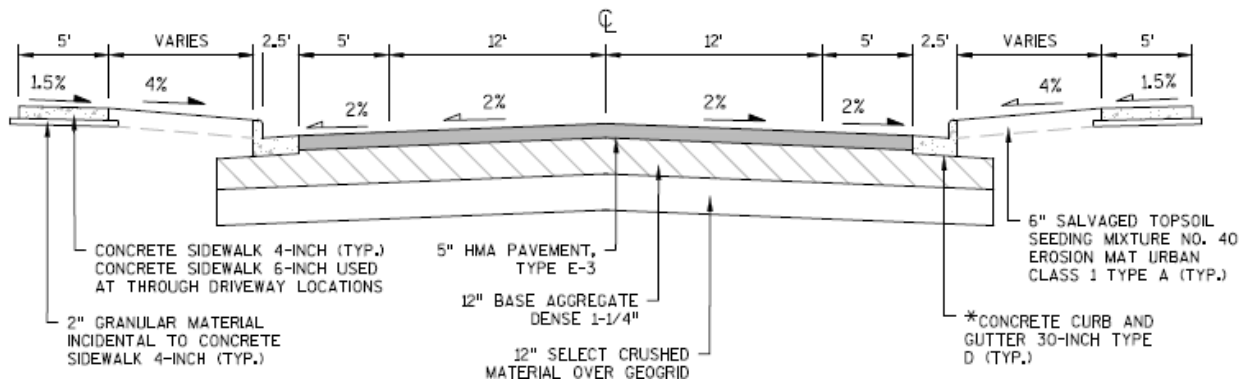

### Proposed Rural Cross Section

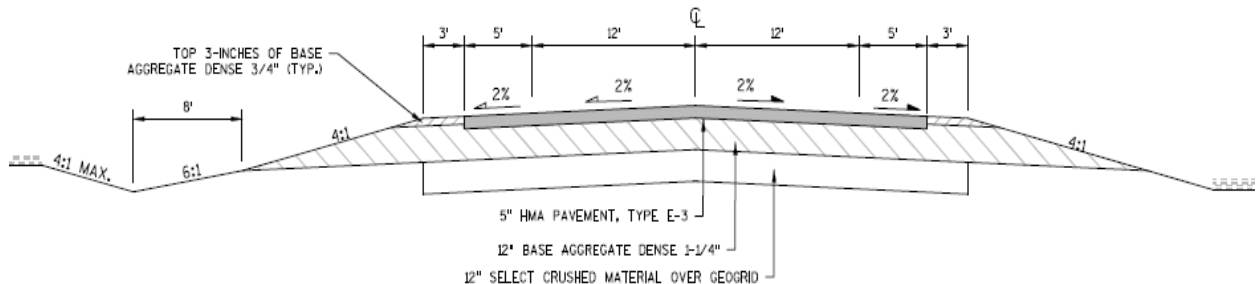



1693-05-02  
WIS 69  
New Glarus – Verona  
County D to Valley Road

