

PART TRANSVERSE SECTION AT DIAPHRAGM

SECTION AT INTERIOR GIRDERS THRU DIAPHRAGM FOR SKEW ANGLES > 10°

NOTES
 ALL DIAPHRAGM MATERIAL NOT EMBEDDED IN THE CONCRETE GIRDER SHALL BE PAID FOR AT THE UNIT PRICE BID FOR "STEEL DIAPHRAGMS B-1-1", EACH.
 EACH DIAPHRAGM BETWEEN GIRDERS SHALL CONSTITUTE ONE UNIT.
 ALL DIAPHRAGM STRUCTURAL STEEL SHALL BE ASTM A709 GRADE 36.
 ALL DIAPHRAGM MATERIAL INCLUDING BOLTS, NUTS AND WASHERS SHALL BE GALVANIZED AFTER FABRICATION.
 STEEL DIAPHRAGM TO CONCRETE WEB CONNECTION SHALL BE SNUG-TIGHT PLUS 1/4 TURN, UNLESS NOTED OTHERWISE. HIGH STRENGTH BOLTS FOR WEB CONNECTION SHALL MEET THE REQUIREMENTS FOR ASTM A325 OR ASTM A449.
DESIGNER NOTES
 FOR SPANS EQUAL TO OR LESS THAN 80'-0", PLACE ONE DIAPHRAGM AT MID-LENGTH OF GIRDER. FOR SPANS OVER 80'-0", PLACE AT 1/3 AND 2/3 POINTS.
 ON THE PLANS, SHOW LOCATION OF INSERTS/HOLES FOR DIAPHRAGM TO WEB CONNECTION, NOT ONLY FROM THE BOTTOM OF THE GIRDER (DIM "A" AND "B"), BUT ALSO FROM THE ENDS OF EACH GIRDER.

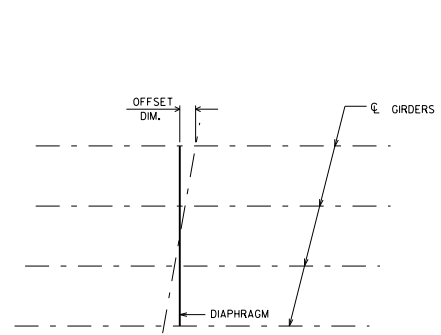

PLAN FOR SKEW ANGLES ≤ 10°

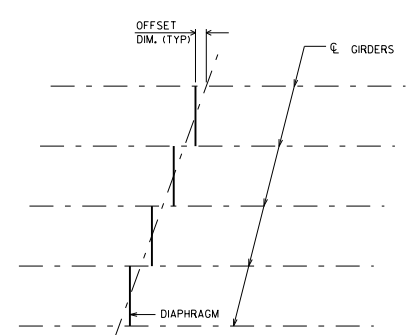

PLAN FOR SKEW ANGLES > 10°

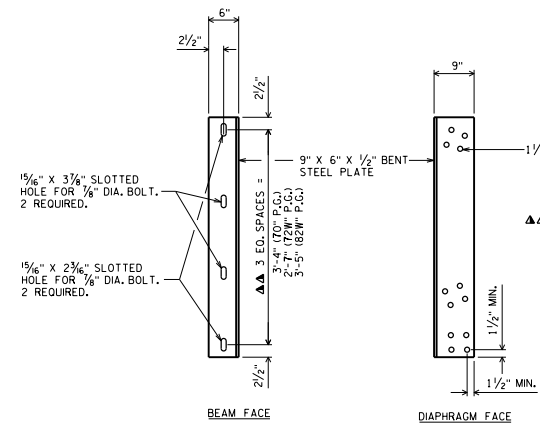

DIAPHRAGM SUPPORT

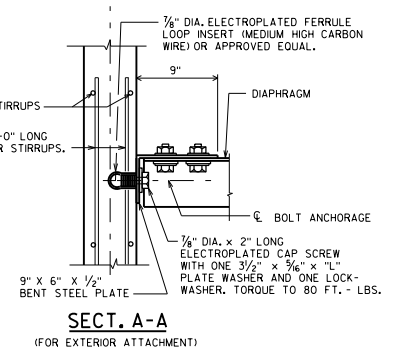

SECT. A-A (FOR EXTERIOR ATTACHMENT)

INTERMEDIATE STEEL DIAPHRAGMS FOR 70", 72W" & 82W" PRESTRESSED GIRDERS

BUREAU OF STRUCTURES

WISCONSIN DEPARTMENT OF TRANSPORTATION

APPROVED: Bill Oliva DATE: 7-17