

**CONCRETE
CAST-IN-PLACE PILING**

REFER TO STANDARD 11.01 FOR SECTION
THRU REINFORCED CAST-IN-PLACE PILING
WHEN PILES ARE EXPOSED.

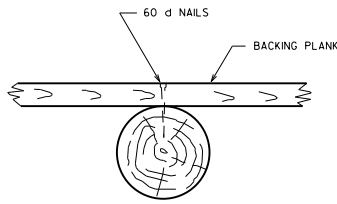

TIMBER PILING

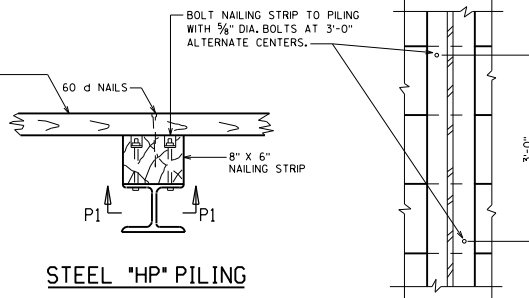

STEEL "HP" PILING

SECTION P1

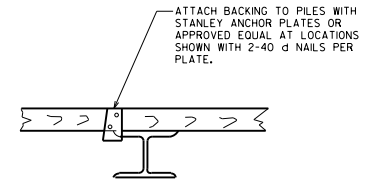

**STEEL "HP" PILING
(ALTERNATE ATTACHMENT)**

BODY & WING PLANK CONNECTION DETAILS

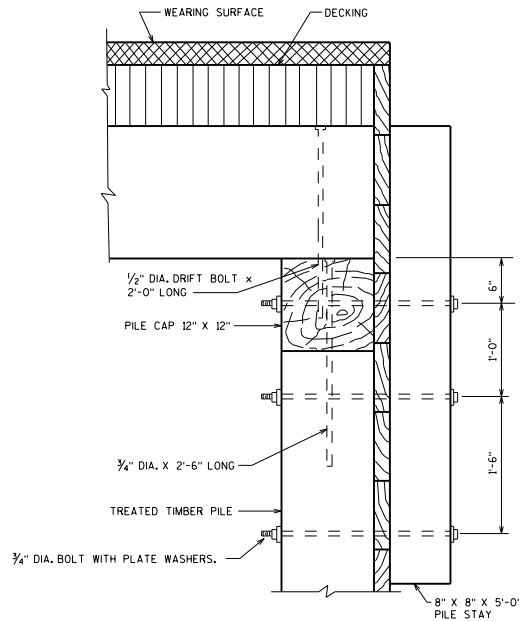

**PILE CAP DETAIL
(TIMBER GIRDER)**

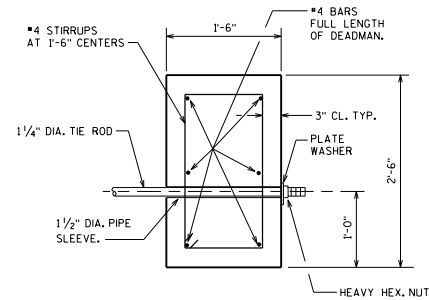

SECTION THRU DEADMAN

TIMBER ABUTMENT DETAILS



APPROVED: Bill Oliva DATE: 7-16