

SKEWS 0° - 15°

SKEWS > 15° ≤ 30°

SKEW > 30°

W24 X 55 TYPICAL CONN.

USE W24x55 IN PLACE OF MC18x42.7 WHEN LENGTH OF DIAPHRAGM EXCEEDS 13'-6" BUT < 22'-0". (SKEW > 15° ≤ 30° SHOWN.)

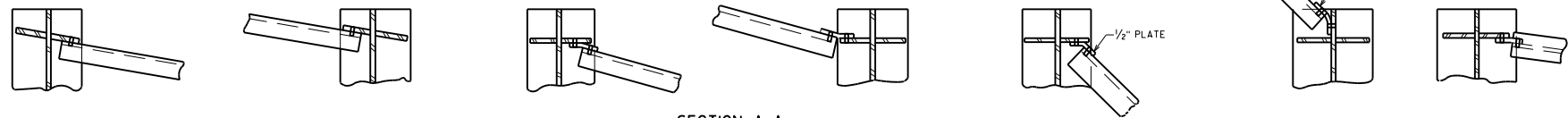

SECTION A-A

END DIAPHRAGM CONNECTIONS - WEB DEPTHS ≤ 48"

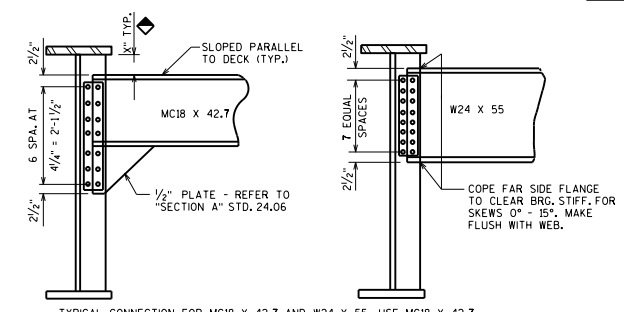

TYPICAL CONNECTION FOR MC18 X 42.7 AND W24 X 55. USE MC18 X 42.7 WHEN DIAPHRAGM LENGTH IS ≤ 13'-6". USE W24 X 55 FOR LENGTHS > 13'-6" < 22'-0". (SKEW > 15° ≤ 30° SHOWN)

END DIAPHRAGM CONNECTIONS - WEB DEPTHS > 48" ≤ 60"

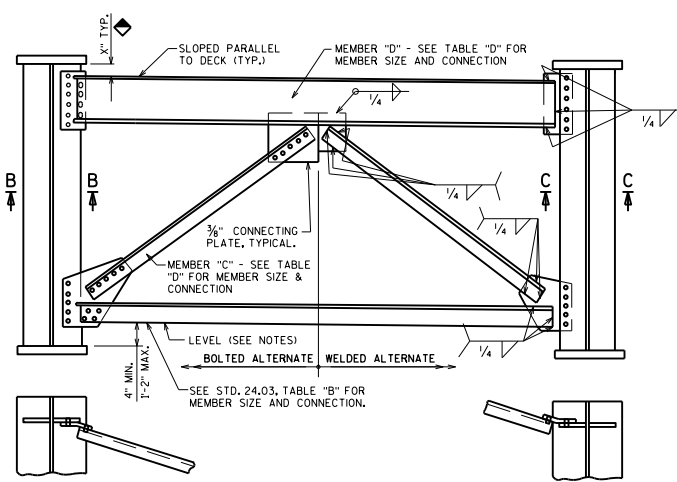

SECTION B-B

SECTION C-C

END DIAPHRAGM CONNECTIONS - WEB DEPTHS > 60"

SKEWS > 15° ≤ 30° SHOWN

NOTES

ALL BOLTED CONNECTIONS SHALL BE FRICTION TYPE USING 3/4" DIA. HIGH STRENGTH ASTM A325 BOLTS WITH DOUBLE WASHERS.
 LOWER CROSS FRAME MEMBERS ARE SLOPED WHEN DIFFERENCE IN ADJACENT BOTTOM FLANGE ELEVATIONS EXCEEDS 6". HOLD 8" FROM TOP OF ADJACENT FLANGES TO BOTTOM OF DIAPHRAGMS OR LOWER CROSS FRAME WHEN THESE MEMBERS ARE SLOPED.
 LOWER CROSS FRAME MEMBERS THAT ARE LEVEL SHALL BE PLACED 4" ABOVE THE TOP OF THE HIGHER BOTTOM FLANGE OF ADJACENT GIRDERS.

DESIGNER NOTES

SEE STANDARD 24.02 FOR BEARING STIFFENER COPE & WELD DETAILS.
 FOR WEB DEPTHS GREATER THAN 60", THE NUMBER OF BOLTS REQUIRED BETWEEN BEARING STIFFENERS AND LOWER CONNECTING PLATES EQUALS THE NUMBER OF BOLTS REQUIRED IN MEMBER "C" OR THE NUMBER REQUIRED IN THE LOWER HORIZONTAL MEMBER, WHICHEVER IS GREATER.
 ♦ 3" MINIMUM. USE 3" UNLESS INCREASED TO ACCOMMODATE LARGE EXPANSION DEVICES.

TABLE "D"

MEMBER "C"	WEB DEPTH						MEMBER "D"	MEMBER "D" CONN.				
	5'-0" - 6'-6"		6'-6" - 7'-6"		7'-6" - 8'-9"			NO. OF 3/4" DIA. BOLTS	MEMBER "D"			
MAXIMUM LENGTH	MEMBER "C" SIZE	NO. OF 3/4" DIA. BOLTS	LENGTH OF 1/4" WELD	MEMBER "C" SIZE	NO. OF 3/4" DIA. BOLTS	LENGTH OF 1/4" WELD	MEMBER "C" SIZE	NO. OF 3/4" DIA. BOLTS	MEMBER "D"			
11'-6"	4 x 4 x 3/8"	5	13	4 x 4 x 3/8"	5	12	4 x 4 x 3/8"	5	11	C12 X 20.7	6 ∅ 2 1/2"	4 ∅ 2 1/2"
13'-6"	5 x 5 x 3/8"	6	17	5 x 5 x 3/8"	6	16	5 x 5 x 3/8"	6	15	C12 X 20.7	6 ∅ 2 1/2"	4 ∅ 2 1/2"
17'-6"	6 x 6 x 3/8"	8	20	5 x 5 x 3/8"	7	18	5 x 5 x 3/8"	6	16	C15 X 33.9	7 ∅ 2 1/2"	5 ∅ 2 1/2"
22'-0"	6 x 6 x 3/8"	9	23	6 x 6 x 3/8"	8	21	6 x 6 x 3/8"	7	19	MC18 X 42.7	7 ∅ 2 1/2"	6 ∅ 2 1/2"

NOTE: ALL MEMBER "C" SIZES REPRESENT ANGLES.

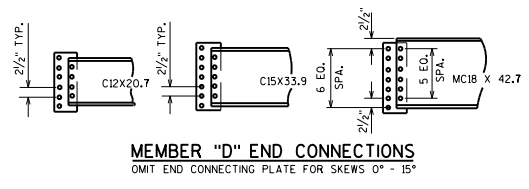

MEMBER "D" END CONNECTIONS
 OMIT END CONNECTING PLATE FOR SKEWS 0° - 15°

END DIAPHRAGMS

**BUREAU OF
STRUCTURES**

DATE:
APPROVED: Bill Oliva 7-21