

EXPANSION BEARING ASSEMBLY
FOR STEEL GIRDER
(SHOW ON PLANS)

	E S. ABUT	E	E	F	F	E	E	E N. ABUT
	PIER 1	PIER 2	PIER 3	PIER 4	PIER 5	PIER 6		
BELOW SHOWS AN EXAMPLE BEARING OFFSET TABLE BASED ON THE SAMPLE BRIDGE SHOWN ABOVE. SUCH A TABLE SHOULD BE PROVIDED FOR STEEL GIRDER BRIDGES. THE OFFSET TABLE MAY BE OMITTED AT THE DISCRETION OF THE DESIGN ENGINEER IF THE VALUES ARE NEGLIGIBLE. (THE BRIDGE SCHEMATIC SHOULD NOT BE SHOWN ON THE PLANS)								
"F"	S. ABUT	PIER 1	PIER 2	PIER 5	PIER 6	N. ABUT		
30	0.7	0.5	0.3	-0.3	-0.5	-0.7		
45	0	0	0	0	0	0		
60	-0.7	-0.5	-0.3	0.3	0.5	0.7		
75	-1.6	-1.1	-0.7	0.7	1.1	1.6		
90	-2.4	-1.7	-1.0	1.0	1.7	2.4		

BEARING OFFSET TABLE
ALL DIMENSIONS IN INCHES
AMBIENT TEMPERATURE DURING GIRDER INSTALLATION

NOTES

FOR STEEL GIRDER BEARINGS:
USE TEMPERATURE SETTING TABLE, RATHER THAN CENTERING BEARINGS BENEATH BEARING STIFFENERS FOR ALL TEMPERATURES.

FOR PRESTRESSED GIRDER BEARINGS:
PLACE BEARINGS AS SHOWN ON THE SUBSTRUCTURE PLAN, PROVIDING ADJUSTMENT FOR SUBSTRUCTURE LOCATION DISCREPANCIES. PLACE EACH GIRDER CENTERED BETWEEN ITS GIVEN BEARINGS.

DESIGNER NOTES

THIS STANDARD SHOULD ONLY BE USED FOR STEEL BEARINGS.

TOP PLATE "A" FOR STEEL GIRDER BEARINGS TO BE DESIGNED TO ACCOUNT FOR THERMAL MOVEMENT AND CONSTRUCTION TOLERANCE. (USE GREATER OF VALUE FROM PROCEDURE BELOW OR SIZE FROM STANDARD 27.0B).

PROCEDURE FOR SIZING TOP PLATE "A":

- 1/2 TEFLON PLATE "B" LENGTH "X"
- + THERMAL MOVEMENT (USE 60-(1-30)=90 DEGREES)
- + 1" CONSTRUCTION TOLERANCE
- = 1/2 TOP PLATE "A" LENGTH (DOUBLE THIS FOR PLATE "A" LENGTH)

ANCHOR PLATES IN PRESTRESSED GIRDERS TO BE DESIGNED TO ACCOUNT FOR THERMAL MOVEMENT, GIRDER SHRINKAGE AND CONSTRUCTION TOLERANCE.

PROCEDURE FOR SIZING ANCHOR PLATE:

- 2 1/2 INCHES + 1/2 TEFLON PLATE LENGTH
- + THERMAL MOVEMENT (USE 60-5-55 DEGREES)
- + SHRINKAGE = 0.0003"/'
- + 1" CONSTRUCTION TOLERANCE
- = 1/2 ANCHOR PLATE LENGTH (DOUBLE THIS FOR ANCHOR PLATE LENGTH)

ACCORDING TO AASHTO, THE LOAD FACTOR FOR TU IS 1.20 FOR DEFORMATIONS. THE PROCEDURE OUTLINED ABOVE SHOULD BE USED WITH A LOAD FACTOR OF 1.0, WITH THE 1" CONSTRUCTION TOLERANCE BEING USED IN LIEU OF THE HIGHER LOAD FACTOR.

THE 90 DEGREE TEMPERATURE RANGE FOR STEEL BEARINGS, BASED ON A 60 DEGREE SETTING TEMPERATURE, IS SLIGHTLY CONSERVATIVE IF THE BEARING OFFSET TABLE IS UTILIZED, SINCE AT 45 DEGREES THE OFFSET WOULD BE ZERO.

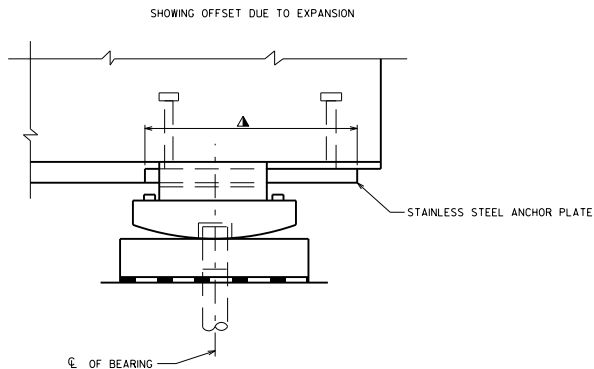

EXPANSION BEARING AT ABUTMENT
PRESTRESSED CONCRETE GIRDER
FOR DESIGNER INFORMATION, ONLY
(DO NOT PUT ON THE PLANS)

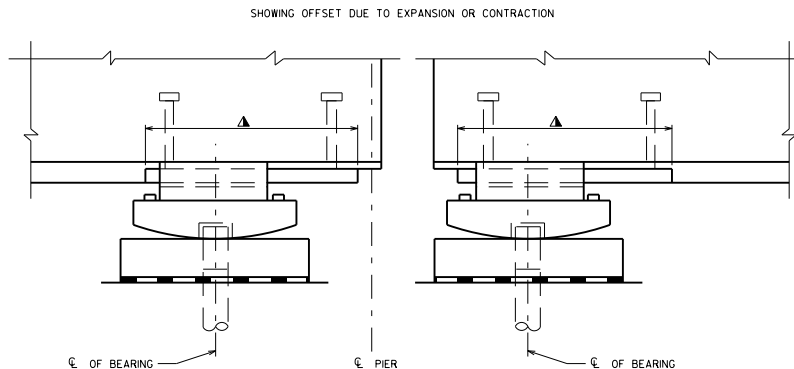

EXPANSION BEARINGS AT PIER
PRESTRESSED GIRDER (CONC. DIAPHS. NOT SHOWN FOR CLARITY)
FOR DESIGNER INFORMATION, ONLY
(DO NOT PUT ON THE PLANS)

STEEL EXPANSION BEARING DETAILS	
	BUREAU OF STRUCTURES
APPROVED: <u>Bill Oliva</u>	DATE: 1-17