

RAILING EXPANSION JOINT DETAIL

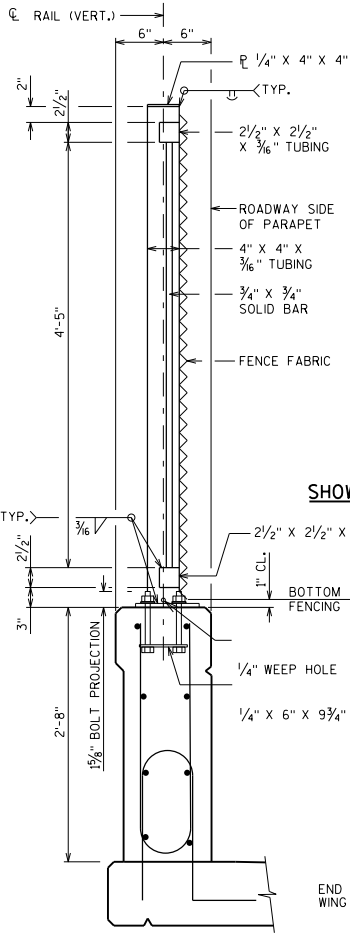

SECTION THRU RAILING
(SEE STD. 30.07 FOR PARAPET REINFORCEMENT AND DETAILS)

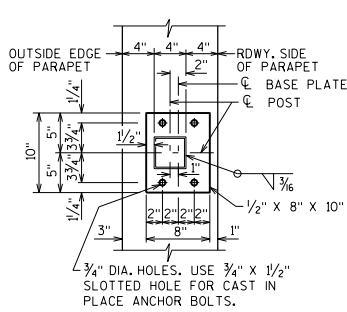

BASE PLATE

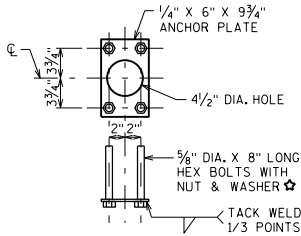

ANCHORAGE DETAIL

★ ALTERNATIVE ANCHORAGE: ADHESIVE ANCHORS 5/8-INCH, EMBED 7" IN CONCRETE. ADHESIVE ANCHORS SHALL CONFORM TO SECTIONS 502.2.12 AND 502.3.14 OF THE STANDARD SPECIFICATIONS.

NOTE: ANCHOR PLATE NOT REQUIRED WHEN ADHESIVE ANCHORS ARE USED.

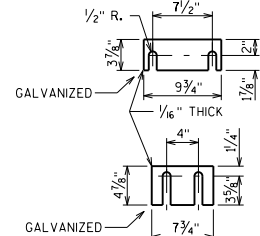

SHIM PLATE DETAILS

TWO SHIMS OF EACH SIZE REQUIRED PER POST

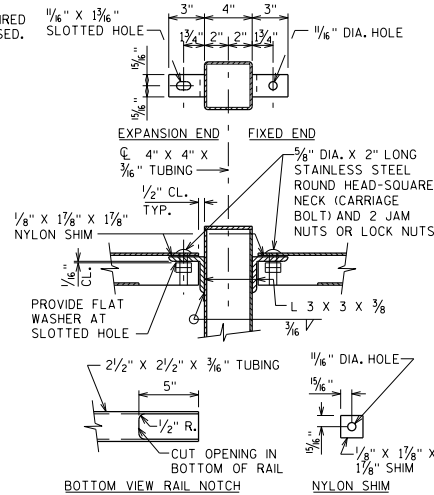

TOP RAIL CONNECTION FOR FENCE W/ BENT TOP

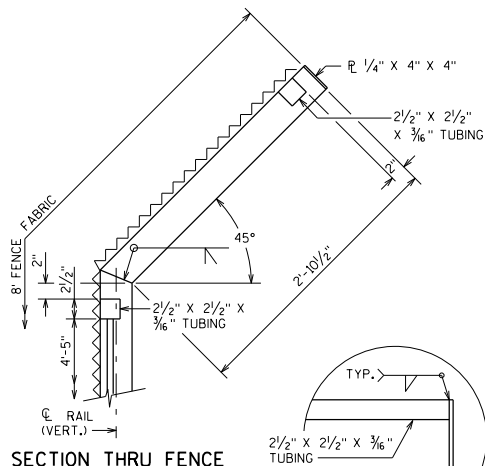

SECTION THRU FENCE SHOWING DETAILS FOR BENT TOP

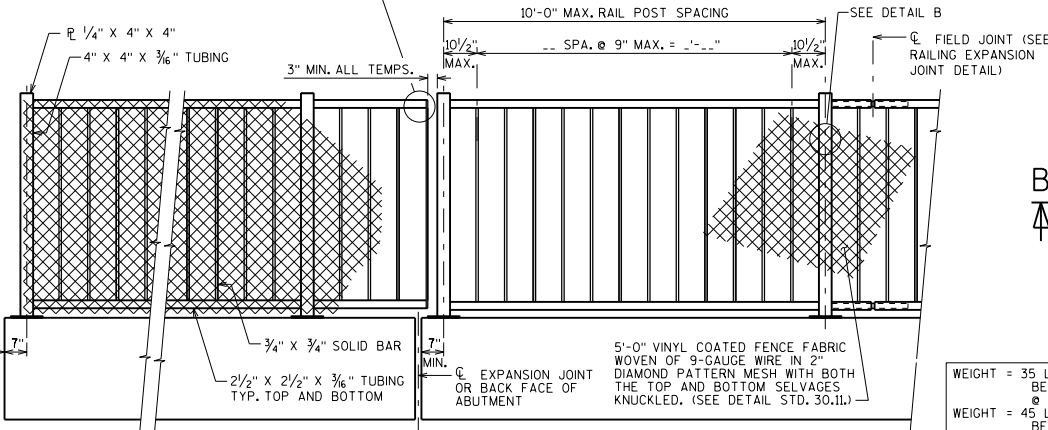

INSIDE ELEVATION OF RAILING

5'-0" VINYL COATED FENCE FABRIC WOVEN OF 9-GAUGE WIRE IN 2" DIAMOND PATTERN MESH WITH BOTH THE TOP AND BOTTOM SELVAGES KNUCKLED. (SEE DETAIL STD. 30.11)

WEIGHT = 35 LB/FT (W/O BENT SECTION @ TOP)
WEIGHT = 45 LB/FT (W/ BENT SECTION @ TOP)

NOTES

POST BASE PLATES SHALL BE FLAT WITH ALL SURFACES SMOOTH AND FREE FROM WARP AND ALL EDGES SMOOTH, STRAIGHT AND VERTICAL. ALL PLATE CUTS SHALL BE MACHINE OR MACHINE FLAME CUT.

STRUCTURAL TUBING SHALL CONFORM TO ASTM A500, GRADE B PLATES, ANGLES, BARS AND SHIMS SHALL CONFORM TO ASTM A709, GRADE 36. FENCE FABRIC SHALL CONFORM TO ASTM F668, CLASS 2B.

ANCHORAGES SHALL BE ACCURATELY PLACED TO PROVIDE CORRECT ALIGNMENT OF RAILING. SET POSTS NORMAL TO GRADE.

ALL POST SPACINGS ARE TAKEN HORIZONTAL ALONG CENTERLINE OF RAILING AT BASE OF POST.

STEEL SHIMS SHALL BE PROVIDED & USED UNDER BASE PLATES WHERE REQUIRED FOR ALIGNMENT, AND SHALL BE GALVANIZED.

CAULK AROUND PERIMETER OF BASE PLATES AND FILL PORTION OF SLOTTED HOLES AROUND ANCHOR BOLTS WITH NON-STAINING GRAY NON-BITUMINOUS JOINT SEALER.

CUT BOTTOM OF POST TO MAKE VERTICAL IN TRANSVERSE DIRECTION.

ANCHOR BOLTS, NUTS AND WASHERS SHALL BE EITHER STAINLESS STEEL OR ASTM 307. IF 307 IS USED, ANCHOR BOLTS, NUTS, AND WASHERS SHALL BE GALVANIZED.

THE BID ITEM SHALL BE "RAILING TUBULAR SCREENING" WHICH SHALL INCLUDE ALL ITEMS SHOWN.

RAILING SHALL BE FABRICATED IN LENGTHS THAT INCLUDE NOT MORE THAN 3 POSTS.

VENT HOLES SHALL BE DRILLED IN MEMBERS AS REQUIRED TO FACILITATE GALVANIZING AND DRAINAGE.

ALL RAILING MATERIAL SHALL BE GALVANIZED AFTER FABRICATION. PRIOR TO GALVANIZING THE STEEL RAILING SHALL BE GIVEN A NO. 6 BLAST CLEANING PER SSPC SPECIFICATIONS. PAINT OVER GALVANIZING WITH AN APPROVED TIE COAT AND TOP COAT AS SPECIFIED IN THE CONTRACT DOCUMENTS. THE RAILING SHALL BE PAINTED AMS STD. COLOR NO. [] (FILL IN COLOR NAME). FENCE FABRIC AND TIES TO BE VINYL-COATED. COLOR SHALL BE (SPECIFY: DARK GREEN, BROWN OR BLACK) IN ACCORDANCE WITH ASTM F934.

THE END OF THE FABRIC SHALL BE ATTACHED TO THE POST BY MEANS OF A TENSION BAR THREADED THROUGH THE END LOOPS OF THE FABRIC AND SECURED TO THE POST WITH CLAMPS & BOLT. THE FABRIC SHALL BE STRETCHED TO REMOVE ALL SLACK.

DESIGNER NOTES

TUBULAR SCREENING MAY BE USED ON STRUCTURES WITH A 45 M.P.H. DESIGN SPEED OR LESS, OR WHEN THE SIDEWALK IS SEPARATED FROM THE ROADWAY BY A PARAPET.

THIS RAILING MAY BE MOUNTED DIRECTLY TO A BRIDGE SIDEWALK OR RETAINING WALL PROVIDED THE SIDEWALK IS SEPARATED FROM THE ROADWAY BY A TRAFFIC BARRIER. USE 6" CLEAR SPACING BETWEEN VERTICAL MEMBERS IF CHAIN LINK FENCE IS NOT USED.

FENCE HEIGHT, CURVED OR STRAIGHT, MESH SIZE, COATING AND COLOR SHOULD BE COORDINATED WITH THE REGION. SEE BRIDGE MANUAL 30.3 (8) FOR ADDITIONAL GUIDANCE.

FABRIC TIE @ 1'-0" MAX. SPA. (TYP. RAIL POSTS & HORIZ. TUBING)

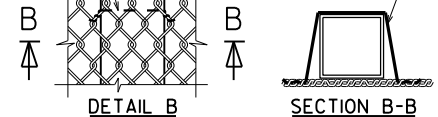

TUBULAR STEEL RAILING SCREENING



APPROVED: Bill Oliva DATE: 1-20