

SECTION THRU PEDESTRIAN STRUCTURE

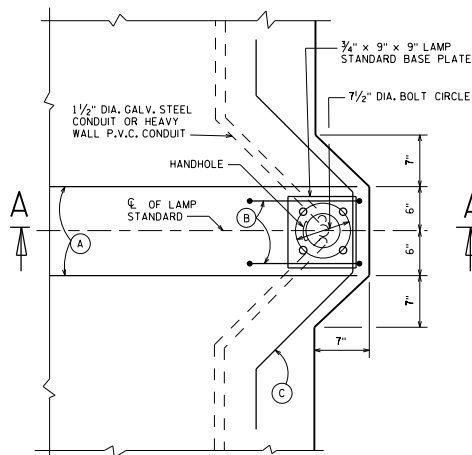

PLAN AT LAMP STANDARD

- BAR STEEL REINFORCEMENT AT EACH LAMP STANDARD.
- (A) 4 - #5 BARS 4'-6" LONG
 - (B) 2 - #4 BARS 4'-3" LONG
 - (C) 2 - #4 BARS 5'-9" LONG

2" x 4" HANDHOLE WITH REINF. FRAME & COVER. HANDHOLE TO FACE TOWARDS WALKWAY SIDE OF LAMP STANDARD, USE STAINLESS STEEL SCREWS ON COVER.

GALV. STEEL DAVIT POLE ROUND 4.43" x 3.17" #11 GAGE AS MFGD. BY UNION METAL AS SHOWN OR BY MILLERBERND MODEL NO. EA4-1205 OR AN APPROVED EQUAL

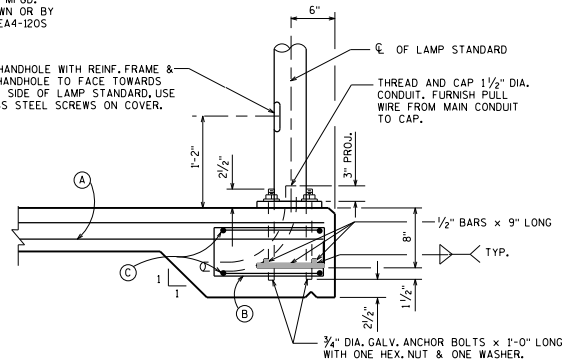

SECTION A-A

PVC 4" WATERSTOP DUMBELL. REOF. IF CONST. JOINT USED. INCIDENTAL TO DECK WORK.

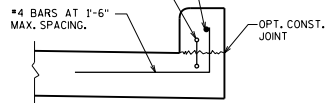

CURB DETAIL

(DECK REINFORCEMENT NOT SHOWN FOR CLARITY. CURB DETAIL WITH RAILING ATTACHMENT SIMILAR)

NOTES

STEEL RAILS, POSTS, HANDRAILS AND SLEEVES SHALL CONFORM TO ASTM F1083, STANDARD WEIGHT PIPE (SCHEDULE 40).

ALL POSTS, INCLUDING LIGHT POLES, SHALL BE SET VERTICAL. SPACE ALL POSTS OF 9'-0" HIGH FENCE OPPOSITE EACH OTHER TO PERMIT SQUARE PLACEMENT OF CROSS RAILS.

MAXIMUM SPACING FOR CROSS RAILS SHALL BE AT ALTERNATE POSTS. ALL END POSTS SHALL HAVE CROSS RAILS.

HANDRAILS SHALL BE CONTINUOUS EXCEPT AT EXPANSION JOINTS WHERE ENDS SHALL BE CAPPED.

WASHERS, HEX NUTS AND ANCHOR BOLTS FOR LIGHT POLES SHALL BE GALVANIZED AND SHALL BE PAID FOR AT THE UNIT PRICE BID FOR "STRUCTURAL STEEL CARBON".

GALVANIZED STEEL SHIMS OF 1/8" THICKNESS SHALL BE USED UNDER LAMP STANDARD BASE PLATE WHERE REQUIRED FOR ALIGNMENT. CAULK AROUND PERIMETER OF THIS PLATE AND FILL PORTION OF SLOTTED HOLE AROUND ANCHOR BOLT IN SHIM WITH NON-STAINING GRAY NON-BITUMINOUS JOINT SEALER.

FOR GALVANIZED CONDUIT PROVIDE GROUNDING LUG IN HANDHOLE. GROUND WIRE FROM LUG TO CONDUIT SHALL BE NUMBER 6 AWG BARE OR WEATHER-PROOF COPPER, SINGLE CONDUCTOR.

SEE STANDARD 30.11 FOR ADDITIONAL "NOTES".

DESIGNER NOTES

▲ TOP OF HANDRAIL GRIPPING SURFACES SHALL BE MOUNTED BETWEEN 30" AND 34" ABOVE WALKING SURFACE. USE 30" NEAR SCHOOL ZONES.

FENCE HEIGHT, CURVED OR STRAIGHT, MESH SIZE, COATING AND COLOR SHOULD BE COORDINATED WITH THE REGION AND ALL OTHER APPLICABLE AGENCIES. SEE BRIDGE MANUAL SECTION 30.3 FOR ADDITIONAL GUIDANCE.

SEE STANDARD 30.11 FOR ADDITIONAL "DESIGNER NOTES".

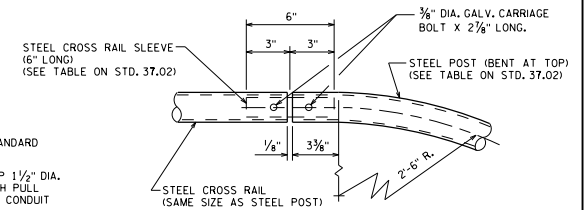

DETAIL OF CROSS RAIL AT TOP

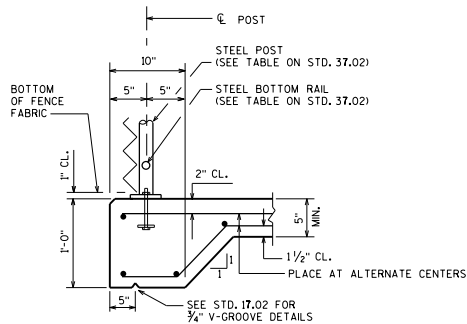

DETAIL 'A'

SEE STANDARD 30.11 FOR BASE PLATE, ANCHOR PLATE, SHIM, POST SLEEVE AND ANCHORAGE DETAILS. SEE THIS STANDARD ALSO FOR FENCE FABRIC REQUIREMENTS.

PEDESTRIAN OVERPASS	
	BUREAU OF STRUCTURES
APPROVED: <u>Bill Oliva</u>	DATE: 1-21