

AVOID PLACING A BENCH MARK CAP BELOW A RAIL OR FENCE SYSTEM THAT IS ATTACHED TO THE TOP OF THE PARAPET.

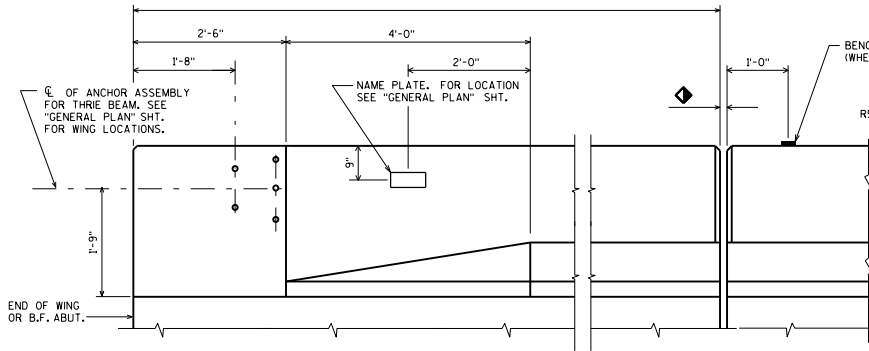

INSIDE ELEVATION

SECTION A

SECTION B

SECTION C

BILL OF BARS
FOR ABUTMENT PARAPETS

BAR MARK	COUNT	ABUT.	ABUT.	LENGTH	BENT	LOCATION
R501	X			4'-7"	X	PARAPET VERT.
R502	X			2'-4"	X	PARAPET VERT.
R503	X			4'-7"	X	PARAPET VERT.
R504	X					PARAPET HORIZ.
R505	X			4'-10"	X	PARAPET VERT.
R506	X				X	PARAPET HORIZ.
S501	X			4'-5"	X	PARAPET VERT.
S502	X			2'-4"	X	PARAPET VERT.
S503	X			4'-2"	X	PARAPET VERT.

ROADWAY OPENING OR 2 1/2" MIN. FOR EXPANSION JOINT. USE 1/2" OPENING WITH FILLER FOR A1 ABUTMENTS

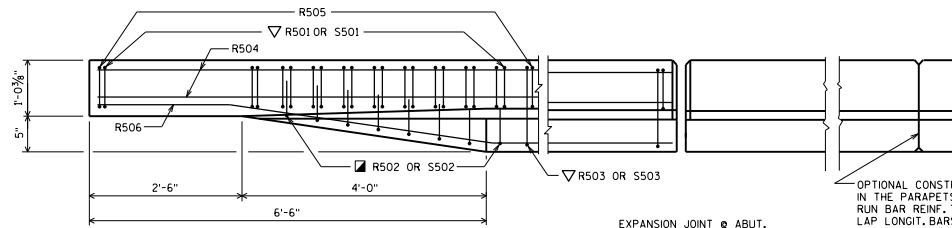

PLAN

EXPANSION JOINT @ ABUT.
0° SKEW SHOWN. MATCH EXP. JT. OPENING.
FOR TYPE A1 ABUT., USE 1/2" FILLER TO TOP OF PARAPET. SEE STD. 12.01.

OPTIONAL CONSTRUCTION JOINTS IN THE PARAPETS MAY BE USED. RUN BAR REINF. THRU THE JOINT. LAP LONGIT. BARS A MIN. OF 1'-9". MIN. JOINT SPACING OF 80'-0". DEFINE CONST. JOINT WITH A 3/4" V-GROOVE.

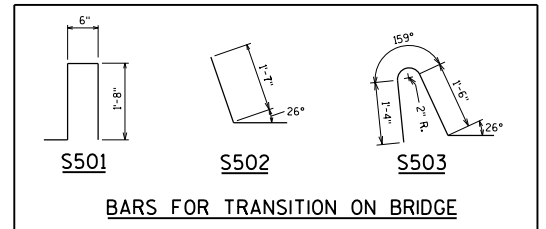
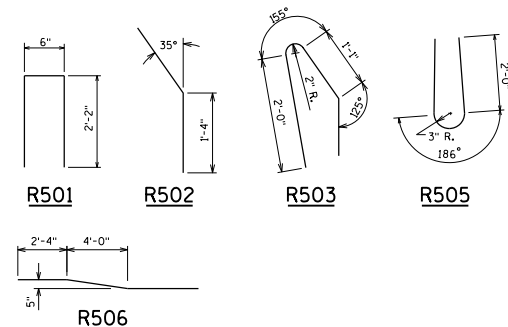
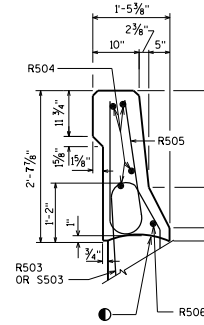

BARS FOR TRANSITION ON BRIDGE

AREA = 2.58 SF
WEIGHT = 387 LB/FT

CONST. JOINT - STRIKE OFF AS SHOWN.

R502 BARS MAY BE PLACED AFTER CONCRETE IS POURED BUT BEFORE INITIAL SET HAS TAKEN PLACE. USE CARE TO PLACE R502 OR S502 BARS CORRECTLY ALONG TRANSITION OF PARAPET.

R501 AND R503 BARS TO BE TIED TO WING STEEL BEFORE WING IS POURED.

A R503 BAR MAY BE USED IN LIEU OF A S503 BAR ADJACENT TO THE PAVING NOTCH ON TYPE A1 ABUTMENTS.

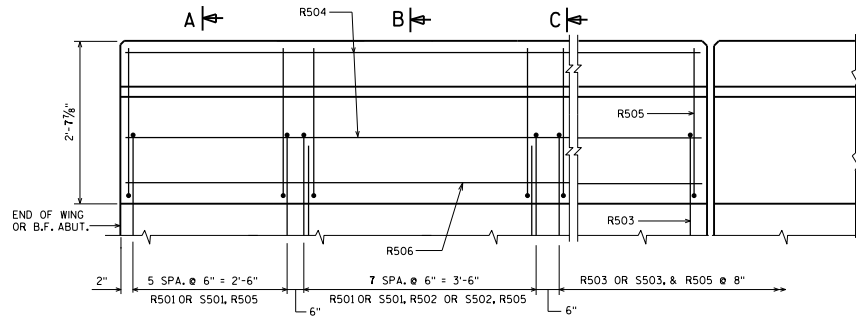

OUTSIDE ELEVATION

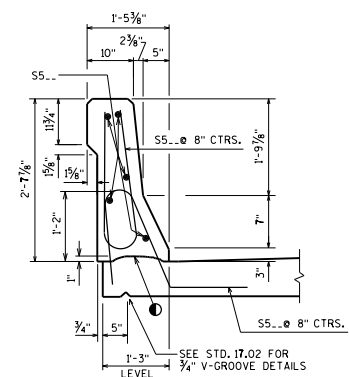

SECTION THRU PARAPET ON BRIDGE

SLOPED FACE PARAPET 'LF'



APPROVED: Bill Oliva DATE: 1-19