

1

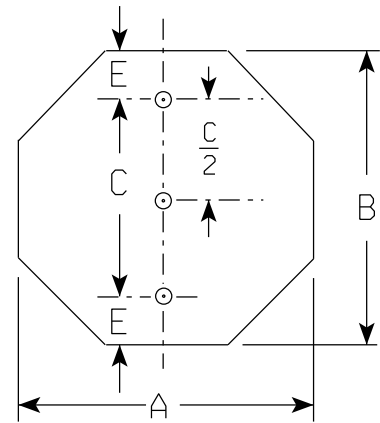

2

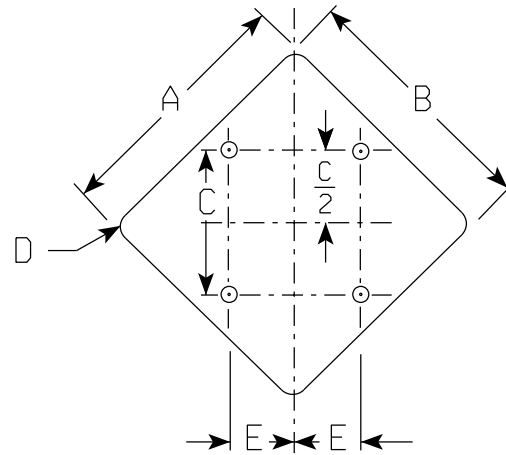

3

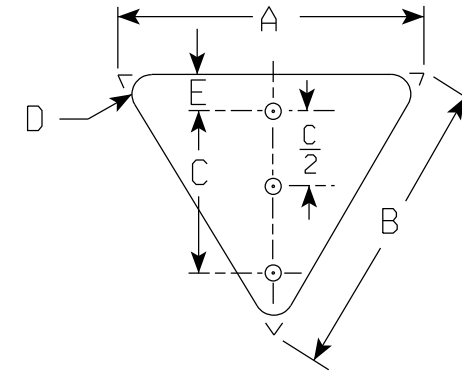

4

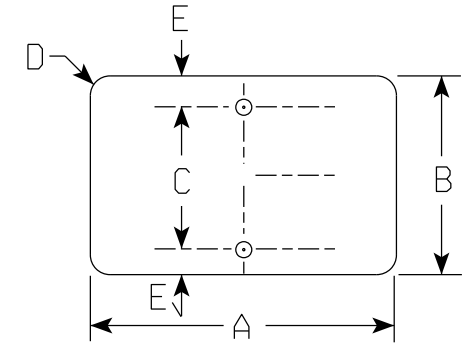

5

NOTES

1. All sign blanks shall have $\frac{7}{16}$ " Diameter mounting hole.

ALUMINUM THICKNESS

SIGN WIDTH	NOMINAL THICKNESS
30 inches and under	0.080 inch
Greater than 30-36 inches	0.100 inch
Over 36 inches	0.125 inch

STOP SIGN THICKNESS

SIGN WIDTH	NOMINAL THICKNESS
30 inches	0.100 inch
36-48 inches	0.125 inch

TYPE 1						
A	B	C	D	E	Area Sq. Ft.	Mounting Holes
18	18	18	1½	14	2.25	2
24	24	24	1½	20	4.0	2
30	30	30	1¾	22	6.25	2
36	36	36	2¼	26	9.0	2

TYPE 4						
A	B	C	D	E	Area Sq. Ft.	Mounting Holes
18	18	14	1	2	1.95	2
36	36	24	2	2	3.9	2
48	48	32	3	3	7.0	2

TYPE 5 CONT'D.						
A	B	C	D	E	Area Sq. Ft.	Mounting Holes
30	30	22	1⅞	4	6.25	2
36	12	8	1½	2	3.0	2
36	18	14	1½	2	4.5	2
36	24	20	1½	2	6.0	2
36	36	26	2¼	5	9.0	2
40	18	14	1½	2	5.00	2
42	21	17	1⅞	2	6.125	2
42	30	22	1⅞	4	8.75	2
48	24	20	1⅞	2	8.0	2

TYPE 2					
A	B	C	E	Area Sq. Ft.	Mounting Holes
24	24	20	2	3.31	2
30	30	24	3	5.18	2
36	36	28	4	7.46	2
48	48	36	6	13.25	3

TYPE 5						
A	B	C	D	E	Area Sq. Ft.	Mounting Holes
8	8	6	1½	1	0.44	2
12	12	9	1½	1½	1.00	2
18	18	14	1½	2	2.25	2
21	15	11	1½	2	2.19	2
21	21	17	1½	2	3.06	2
24	12	8	1½	2	2.0	2
24	18	14	1½	2	3.0	2
24	24	20	1½	2	4.0	2
30	12	8	1½	2	2.5	2
30	15	11	1½	2	3.13	2
30	18	14	1½	2	3.75	2
30	21	17	1½	2	4.37	2
30	24	20	1½	2	5.0	2

TYPE 3						
A	B	C	D	E	Area Sq. Ft.	Mounting Holes
48	48	26	3	13	16.0	4

STANDARD LAYOUT OF ALUMINUM SIGN BLANKS
SHEET 1 OF 3

WISCONSIN DEPT OF TRANSPORTATION

APPROVED *Matthew R. Rauch*
for State Traffic Engineer

DATE 8/23/18 PLATE NO. A5-3.24

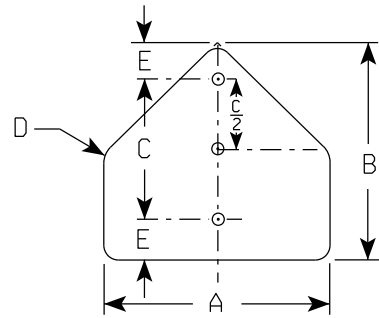

6

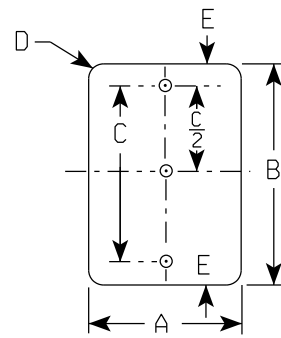

7

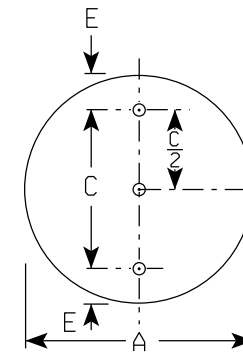

8

NOTES

1. All sign blanks shall have 7/16" Diameter mounting holes.

TYPE 6						
A	B	C	D	E	Area Sq. Ft.	Mounting Holes
30	30	24	1 3/8	3	4.68	2
36	36	26	1 5/8	5	6.75	2
48	48	32	1 7/8	8	12.0	3

TYPE 7 *							
A	B	C	D	E	Area Sq. Ft.	Mounting Holes	
12	18	15	1 1/2	1 1/2	1.5	2	
12	24	20	1 1/2	2	2.0	2	
12	36	24	1 1/2	6	3.0	2	
12	48	32	1 1/2	8	4.0	3	
15	21	18	1 1/2	1 1/2	2.19	2	
18	24	20	1 1/2	2	3.0	2	
18	36	24	1 1/2	6	4.5	2	
18	54	36	2 1/2	9	6.75	3	
21	60	40	1 1/2	10	8.75	3	
21	72	52	1 1/2	10	10.5	3	
24	30	22	1 1/2	4	5.0	2	
24	36	24	1 1/2	6	6.0	2	
24	39	27	1 1/2	6	6.5	3	
24	45	33	1 7/8	6	7.5	3	
24	48	32	1 7/8	8	8.0	3	
24	57	37	1 7/8	10	9.5	3	
36	48	32	1 7/8	8	12.0	3	
30	36	24	1 7/8	6	7.5	2	
36	54	36	2 1/4	9	12.75	3	
36	57	37	1 7/8	10	14.25	3	
48	39	27	1 7/8	10	13.0	3	
48	45	32	1 7/8	10	14.0	3	
48	57	37	3	10	19.0	3	

TYPE 8						
A	B	C	E	Area Sq. Ft.	Mounting Holes	
30	—	24	3	4.91	2	
36	—	26	5	7.07	2	
48	—	32	8	12.5	3	

* FOR SIGNS OVER 57" IN HEIGHT, PROVIDE 3 MOUNTING HOLES AT 10" FROM THE TOP AND BOTTOM OF SIGN AND IN THE CENTER OF SIGN.

STANDARD LAYOUT OF ALUMINUM SIGN BLANKS
SHEET 2 OF 3

WISCONSIN DEPT OF TRANSPORTATION

APPROVED *Matthew R Rauch*
For State Traffic Engineer

DATE 8/23/18 PLATE NO. A5-3.24

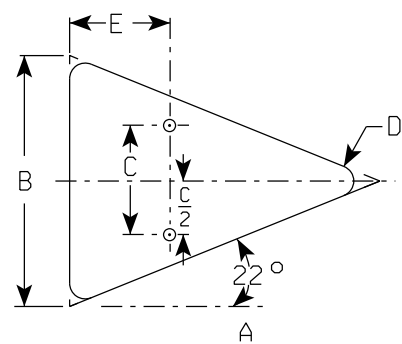

10

TYPE 10 (NOTE 1)						
A	B	C	D	E	Area Sq. Ft.	Mounting Holes
48	36	14	2 1/4	16	6.0	2

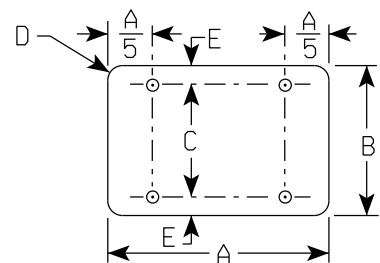

11

TYPE 11						
A	B	C	D	E	Area Sq. Ft.	Mounting Holes
66	12	8	3	2	5.5	4
66	18	14	3	2	8.25	4
66	24	20	3	2	11.0	4
66	30	22	3	4	13.75	4
66	36	28	3	4	16.5	4
66	42	34	3	4	19.25	4
66	48	40	3	4	22.0	4
72	12	8	3	2	6.0	4
72	18	14	3	2	9.0	4
72	24	20	3	2	12.0	4
72	30	22	3	4	15.0	4
72	36	28	3	4	18.0	4
72	42	34	3	4	21.0	4
72	48	40	3	4	24.0	4

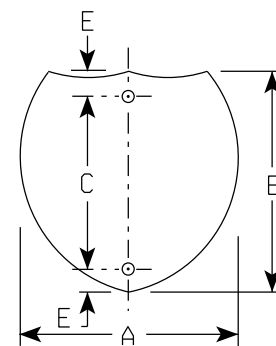

12

TYPE 12 (NOTE 2)					
A	B	C	E	Area Sq. Ft.	Mounting Holes
24	24	18	3	3.13	2
30	24	18	3	3.91	2
36	36	28	4	7.03	2
45	36	28	4	8.79	2

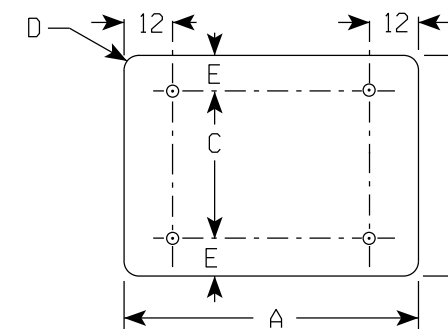

13

TYPE 13						
A	B	C	D	E	Area Sq. Ft.	Mounting Holes
48	60	40	3	10	20.0	4
54	12	8	1 1/2	2	4.5	4
54	15	11	1 1/2	2	5.63	4
54	18	14	1 1/2	2	6.75	4
54	21	17	1 1/2	2	7.88	4
54	24	20	1 7/8	2	9.0	4
54	36	28	1 7/8	4	13.5	4
54	48	40	1 7/8	4	18.0	4
60	12	8	1 1/2	2	5.0	4
60	18	14	1 1/2	2	7.5	4
60	24	20	1 7/8	2	10.0	4
60	30	22	1 7/8	4	12.5	4
60	36	28	1 7/8	4	15.0	4
60	42	34	1 7/8	4	17.5	4
60	48	40	3	4	20.0	4

NOTES

1. Dimension A on type #10 is measured to the theoretical intersections of the edges.
2. Shape of type #12 shall conform to FHWA standard for Interstate route markers.
3. All signs over 60" in width shall have 3" radius on the outside corners of the aluminum blank.
4. For signs over 60" in width see sign plate A4-18 for hole placement.

STANDARD LAYOUT OF ALUMINUM SIGN BLANKS SHEET 3 OF 3

WISCONSIN DEPT OF TRANSPORTATION

APPROVED *Matthew R Rauch*
for State Traffic Engineer

DATE 8/23/18 PLATE NO. A5.3.24

7

7