

STATE PROJECT	FEDERAL PROJECT	
	PROJECT	CONTRACT
2816-03-70	WISC 2024225	1

# STATE OF WISCONSIN DEPARTMENT OF TRANSPORTATION

## PLAN OF PROPOSED IMPROVEMENT

### V RAYMOND CTH U

INTERSECTION WITH 7 MILE ROAD

CTH U  
RACINE COUNTY

STATE PROJECT NUMBER  
**2816-03-70**

APPROVED FOR  
RACINE COUNTY  
DEPARTMENT OF PUBLIC WORKS

Date: 10/25/23 *[Signature]*  
DIRECTOR  
Date: 10-26-23 *[Signature]*  
ENGINEERING SERVICES MANAGER



1300 W. Canal Street, Suite 200  
Milwaukee, WI 53233  
414.347.1607 Fax 414.347.1347



10/25/23 *Katie L. Nakles*  
(Signature)

STATE OF WISCONSIN  
DEPARTMENT OF TRANSPORTATION

PREPARED BY  
Surveyor: EMCS, INC.  
Designer: EMCS, INC.  
Project Manager: MICHAEL BAIRD  
Regional Examiner: REGIONAL EXAMINER  
Regional Supervisor: BRIAN BOOTHBY

APPROVED FOR THE DEPARTMENT  
DATE: 10/27/2023 *Michael Baird*  
(Signature)

E

ORDER OF SHEETS

Section No.	Title
1	Title
2	Typical Sections and Details
3	Estimate of Quantities
3	Miscellaneous Quantities
4	Right of Way Plat
5	Plan and Profile
6	Standard Detail Drawings
7	Sign Plates
8	Structure Plans
9	Computer Earthwork Data
9	Cross Sections

TOTAL SHEETS = 184



13

DESIGN DESIGNATION

	CTH U	7 MILE RD
A.A.D.T. 2020	= 3950	3270
A.A.D.T. 2044	= 5688	4708
D.H.V.	= 467	377
D.D.	= 55/45	54/46
T.	= 8.1%	5.7%
DESIGN SPEED	= 50 MPH	50 MPH
ESALS	= 480,000	...

CONVENTIONAL SYMBOLS

PLAN	PROFILE
CORPORATE LIMITS	GRADE LINE
PROPERTY LINE	ORIGINAL GROUND
LOT LINE	MARSH OR ROCK PROFILE (To be noted as such)
LIMITED HIGHWAY EASEMENT	SPECIAL DITCH
EXISTING RIGHT OF WAY	GRADE ELEVATION
PROPOSED OR NEW R/W LINE	CULVERT (Profile View)
SLOPE INTERCEPT	UTILITIES
REFERENCE LINE	ELECTRIC
EXISTING CULVERT	FIBER OPTIC
PROPOSED CULVERT (Box or Pipe)	GAS
COMBUSTIBLE FLUIDS	SANITARY SEWER
MARSH AREA	STORM SEWER
WOODED OR SHRUB AREA	TELEPHONE
	WATER
	UTILITY PEDESTAL
	POWER POLE
	TELEPHONE POLE

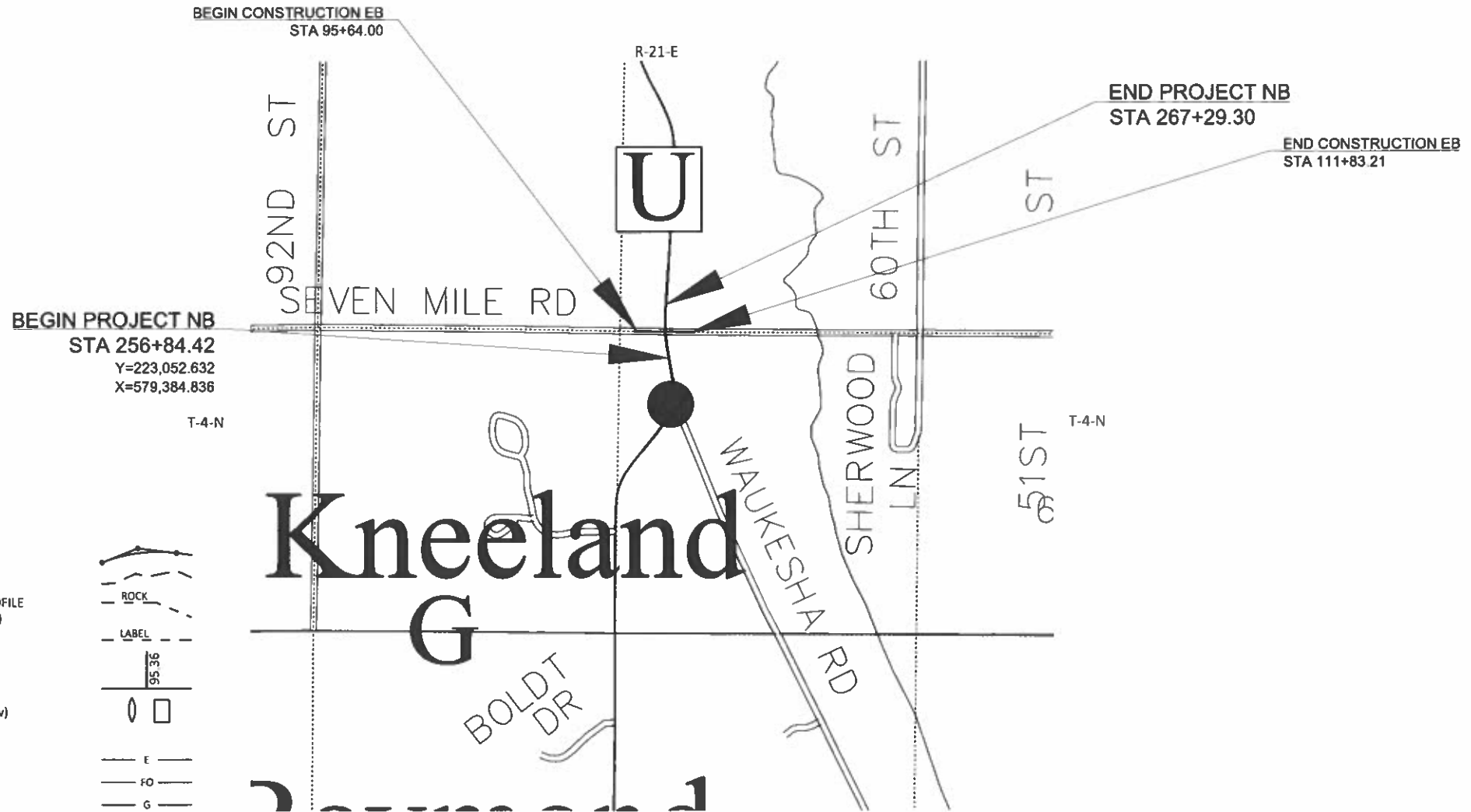

SCALE 0 0.5 MI

TOTAL NET LENGTH OF CENTERLINE = 0.198 MILES

HORIZONTAL POSITIONS SHOWN ON THIS PLAN ARE WISCONSIN COORDINATE REFERENCE SYSTEM (WISCRS), RACINE COUNTY, NAD83 (2011), IN U.S. SURVEY FEET. POSITIONS SHOWN ARE GRID COORDINATES, GRID BEARINGS, AND GRID DISTANCES. GRID DISTANCES ARE THE SAME AS GROUND DISTANCES.

ELEVATIONS ARE REFERENCED TO NAVD 88 (2012). GPS DERIVED ELEVATIONS ARE BASED ON GEOID 18

PROJECT ID: 2816-03-70

COUNTY: RACINE

WITH: N/A

**GENERAL NOTES**

1. NO TREES OR SHRUBS ARE TO BE REMOVED WITHOUT THE APPROVAL OF THE ENGINEER.
2. PRIOR TO ORDERING DRAINAGE PIPES, THE CONTRACTOR SHALL FIELD VERIFY RELATED DRAINAGE INFORMATION IN THE PLAN WITH THE ENGINEER.
3. CROSS DRAIN PIPE LOCATIONS AND ELEVATIONS AS SHOWN ON THE CROSS SECTION SHEETS ARE APPROXIMATE AND SHALL BE ADJUSTED TO FIT FIELD CONDITIONS.
4. EXCAVATION BELOW SUBGRADE (EBS) IS NOT USED TO BALANCE EARTHWORK, EBS IS MEASURED AND PAID FOR AS EXCAVATION COMMON. EBS AREAS ARE DEPICTED BY THE 16-INCH SELECT CRUSHED MATERIAL AS SHOWN IN THE PLANS.
5. SEED, INSTALL EROSION MAT, AND FERTILIZE ALL SALVAGED TOPSOILED AREAS WITHIN 7 WORKING DAYS AFTER GRADING WORK IS COMPLETED.
6. A SAWED JOINT WILL BE REQUIRED WHERE NEW PAVEMENT IS TO MEET AN EXISTING PAVED SURFACE.
7. EXACT LOCATION OF ALL DRIVEWAY ENTRANCES TO BE REVIEWED AND APPROVED BY THE ENGINEER.
8. THE LOCATION OF EXISTING AND PROPOSED UTILITY INSTALLATIONS AS SHOWN ON THE PLANS ARE APPROXIMATE. THERE MAY BE OTHER UTILITY INSTALLATIONS WITHIN THE PROJECT AREA THAT ARE NOT SHOWN.
9. STATIONING, DISTANCES, AND OFFSETS FOR SIGNS SHOWN IN THE PLANS ARE APPROXIMATE AND THE FINAL LOCATION OF SIGNS ARE TO BE DETERMINED BY THE ENGINEER.
10. TRAFFIC CONTROL DEVICES SHALL BE ADJUSTED TO FIT FIELD CONDITIONS AS DIRECTED BY THE ENGINEER.
11. LOCATIONS OF DRAINTILE ON THE PLAN ARE BASED ON AS-BUILT OR PROPERTY OWNER INTERVIEWS. DRAINTILE EXPLORATION ITEM IS TO BE USED TO VERIFY THE EXACT SIZE AND LOCATION
12. ALL STATIONS IN PLANS ARE BASED ON NORTHBOUND AND EASTBOUND ALIGNMENTS. ALL STATIONS REFERENCED IN THE QUANTITIES ARE BASED OF OFF THE REFERENCED ALIGNMENT.

**STANDARD ABBREVIATIONS**

AGG	AGGREGATE	LT	LEFT
ASPH	ASPHALTIC	LF	LINEAR FOOT
BM	BENCH MARK	MH	MANHOLE
CL	CENTER LINE	NB	NORTHBOUND
CONC	CONCRETE	PAVT	PAVEMENT
CO	COUNTY	PU	PIPE UNDERDRAIN
CY	CUBIC YARD	PE	PRIVATE ENTRANCE
CULV	CULVERT	PROJ	PROJECT
CP	CULVERT PIPE	PL	PROPERTY LINE
C&G	CURB AND GUTTER	PRW	PROPOSED RIGHT OF WAY
DIA	DIAMETER	RL	REFERENCE LINE
DWY	DRIVEWAY	ERW	EXISTING RIGHT OF WAY
EB	EASTBOUND	RDWY	ROADWAY
ELEV	ELEVATION	SHLDR	SHOULDER
EW	ENDWALL	SB	SOUTHBOUND
ENT	ENTRANCE	SI	SLOPE INTERCEPT
EXC	EXCAVATION	SS	STORM SEWER
F	FILL	TEL	TELEPHONE
FL	FLOW LINE	TEMP	TEMPORARY
FO	FIBER OPTIC	UG	UNDERGROUND
INL	INLET	VOL	VOLUME
INV	INVERT	W	WATER
JT	JOINT	WB	WESTBOUND

**DESIGN CONTACT**

EMCS, INC.  
 KATIE NAKLES  
 PROJECT MANAGER  
 1300 W CANAL STREET, SUITE 200  
 MILWAUKEE, WI 53233  
 (414) 347-1607  
 KNAKLES@EMCSINC.COM

**WDNR LIAISON**

BENTON STELZEL  
 ENVIRONMENTAL ANALYST & REVIEW SPECIALIST  
 141 NW BARSTOW ST. ROOM 180  
 WAUKESHA, WI, 53187  
 (262) 623-0194  
 BENTONSTELZEL@WISCONSIN.GOV

**RACINE COUNTY**

CHRIS GALLAGHER  
 ASSISTANT ENGINEERING MANAGER  
 14200 WASHINGTON AVE  
 STURTEVANT, WI, 53177  
 (262) 886-8440  
 CHRISTOPHER.GALLAGHER@RACINECOUNTY.COM

**UTILITIES**

**COMMUNICATIONS**

AT&T DISTRIBUTION  
 MIKE VANBOVEN  
 OUTSIDE PLANT ENGINEER  
 411 7TH ST  
 RACINE, WI 53403  
 MV3658@ATT.COM

**GAS UTILITIES**

WE ENERGIES - GAS  
 RILEY DOERFLINGER  
 DESIGNER  
 (414) 640-1374  
 RILEY.DOERFLINGER@WE-ENERGIES.COM

**COMMUNICATIONS**

E-VERGENT  
 TOM PIETILA  
 DIRECTOR OF ENGINEERING  
 2524 76TH ST  
 FRANKSVILLE, WI 53126  
 TPIETILA@E-VERGENT.COM

**ELECTRICITY**

WE ENERGIES - ELEC  
 LUCAS WANDALL  
 DESIGNER - RASC  
 (414) 627-3120  
 LUCAS.WANDALL@WE-ENERGIES.COM

**OTHER CONTACTS**

**SEWRPC**

CHRISTOPHER J. JORS  
 W239 N1812 ROCKWOOD DRIVE  
 P.O BOX 1607  
 WAUKESHA, WI 53187-1607  
 (262) 953-3246

**ORDER OF SECTION 2 SHEETS**

- PROJECT OVERVIEW
- TYPICAL SECTIONS
- CONSTRUCTION DETAILS
- PLAN DETAILS
- PAVING DETAILS
- EROSION CONTROL
- STORM SEWER
- PERMANENT SIGNING
- LIGHTING PLAN
- PAVEMENT MARKING
- TRAFFIC CONTROL
- DETOUR ROUTE
- ALIGNMENT DETAILS

TOTAL LAYER PAVEMENT THICKNESS	LAYERS	HMA PAVEMENT ITEMS
5"	2" (UPPER) 3" (LOWER)	4 LT 58-28 S (UPPER) 3 LT 58-28 S (LOWER)
2"	2" (UPPER)	4 LT 58-28 S (UPPER)



Dial **811** or (800)242-8511

www.DiggersHotline.com



PROJECT NO: 2816-03-70	HWY: CTH U	COUNTY: RACINE	PROJECT OVERVIEW	SHEET	E
------------------------	------------	----------------	------------------	-------	---

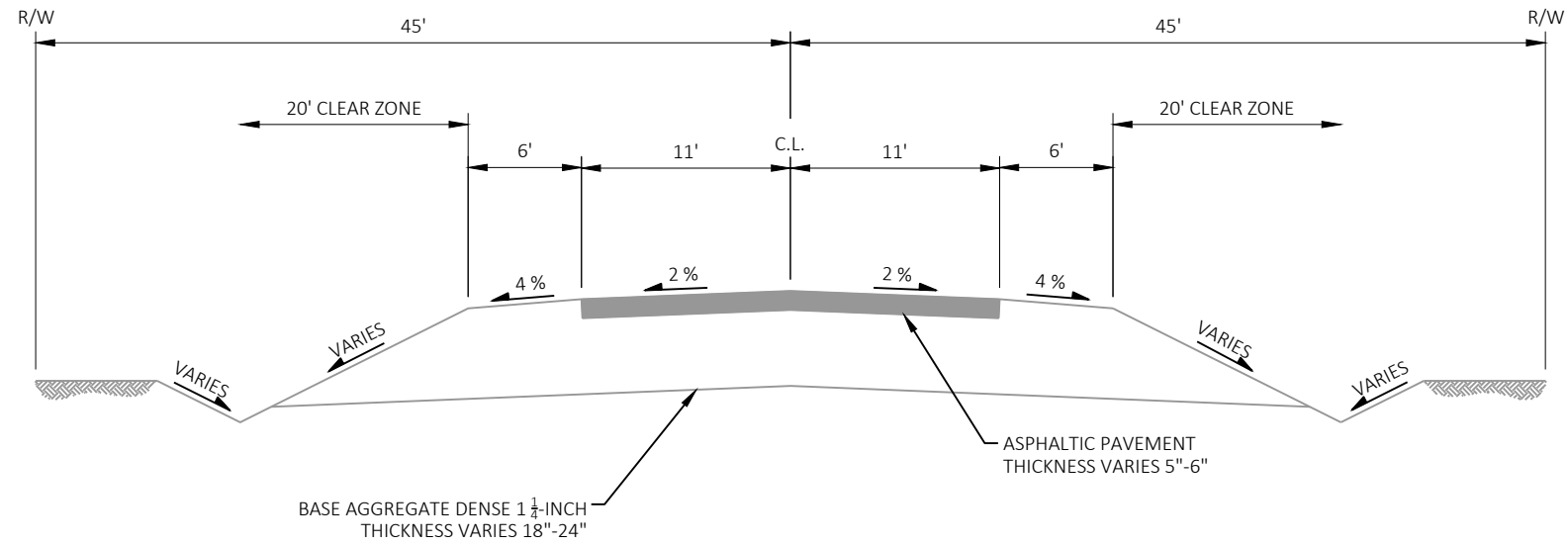

**EXISTING TYPICAL SECTION**

C.T.H. - U  
STA 256+84.42 - 267+29.30

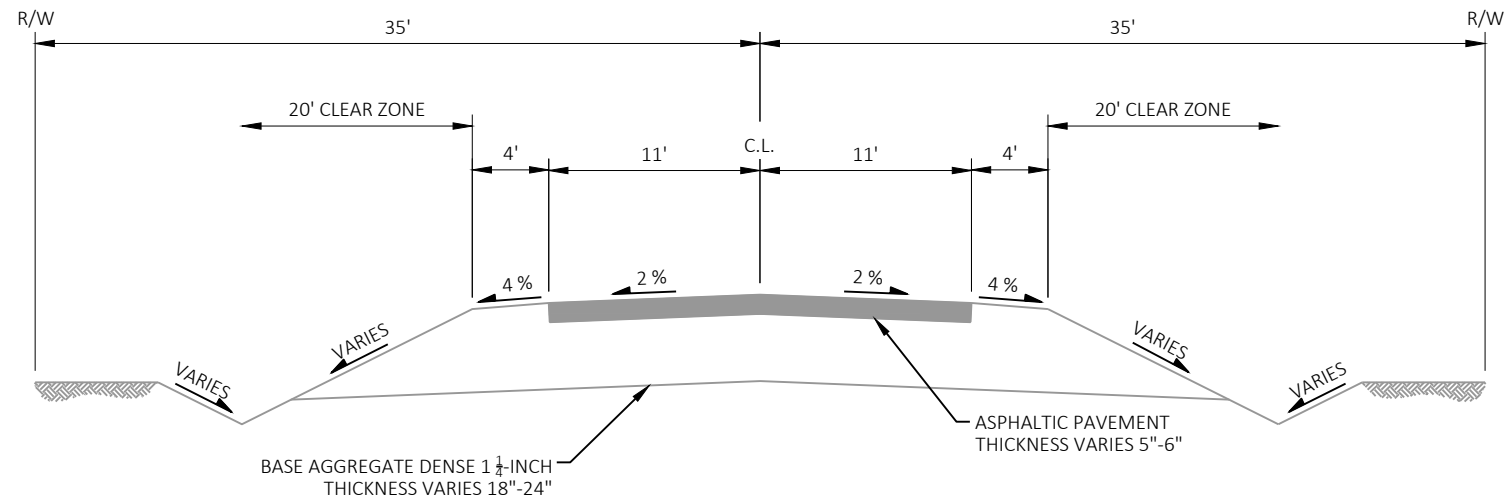

**EXISTING TYPICAL SECTION**

7 MILE RD  
STA 95+64.00 - 111+83.21



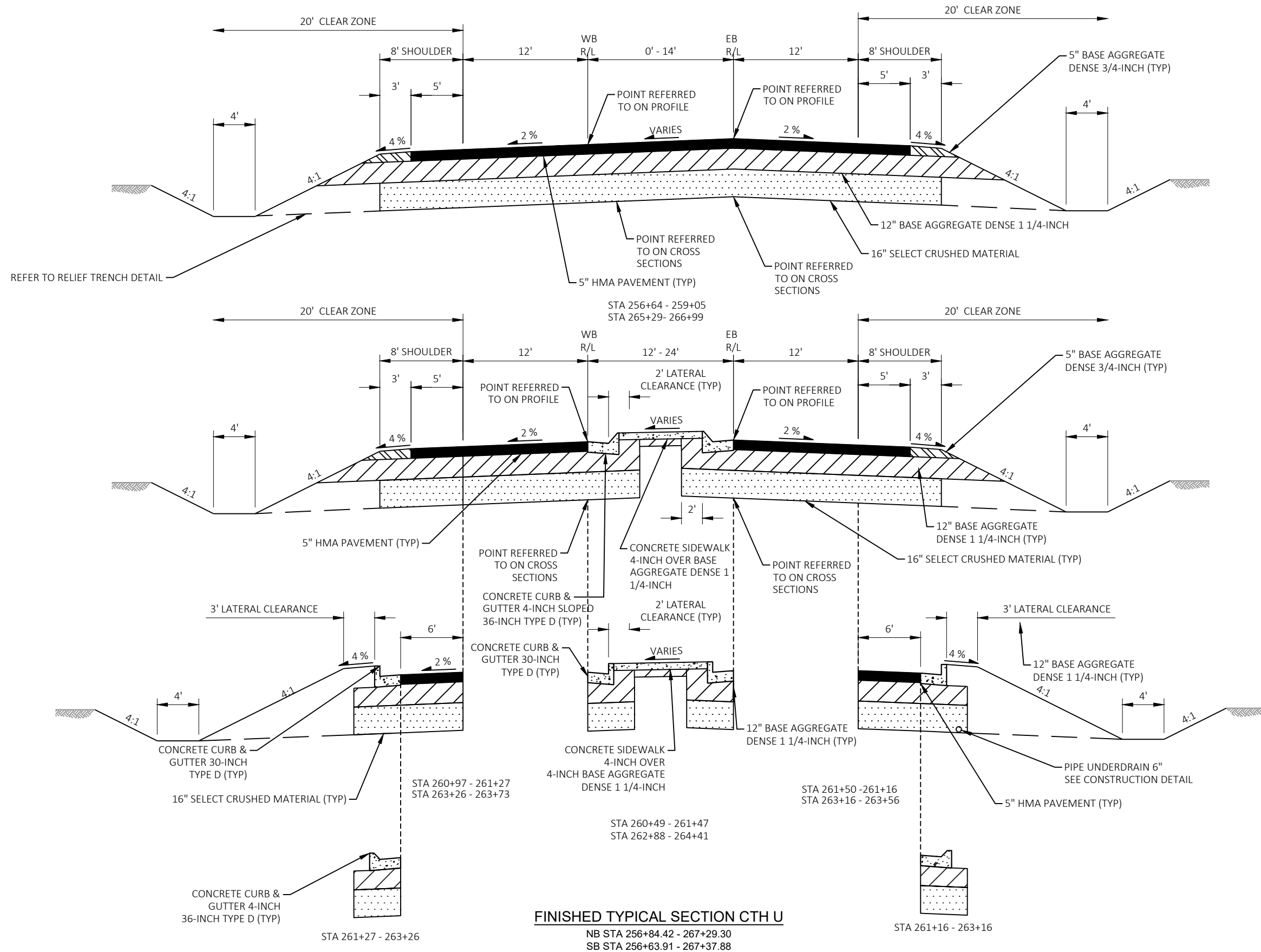

**FINISHED TYPICAL SECTION CTH U**  
 NB STA 256+84.42 - 267+29.30  
 SB STA 256+63.91 - 267+37.88

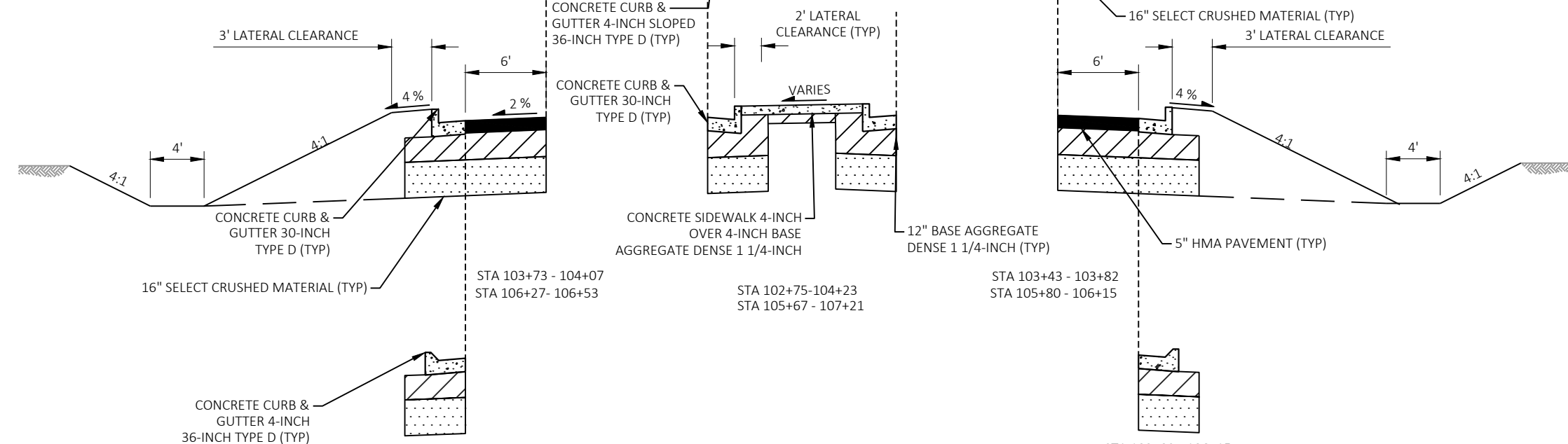
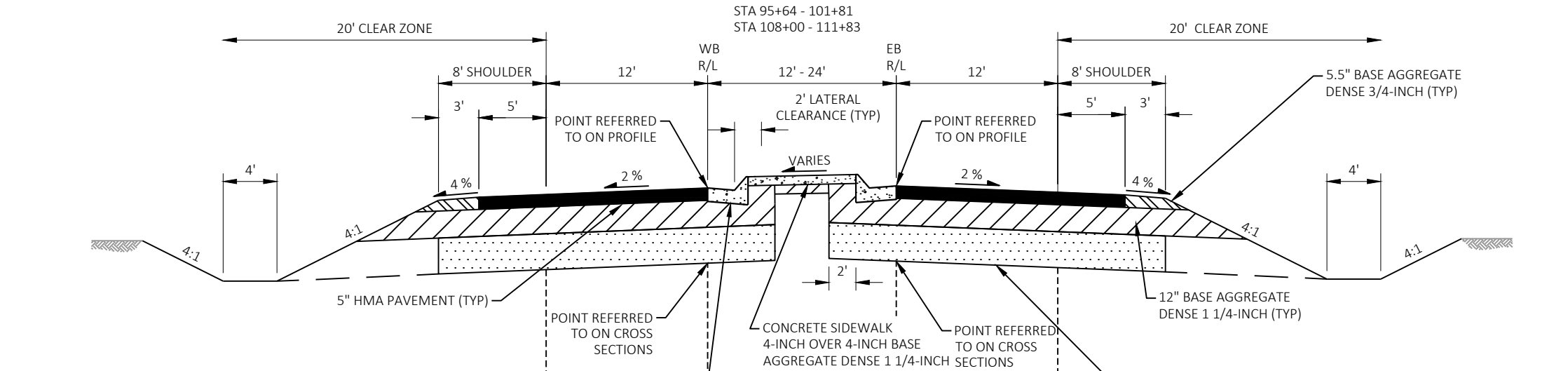
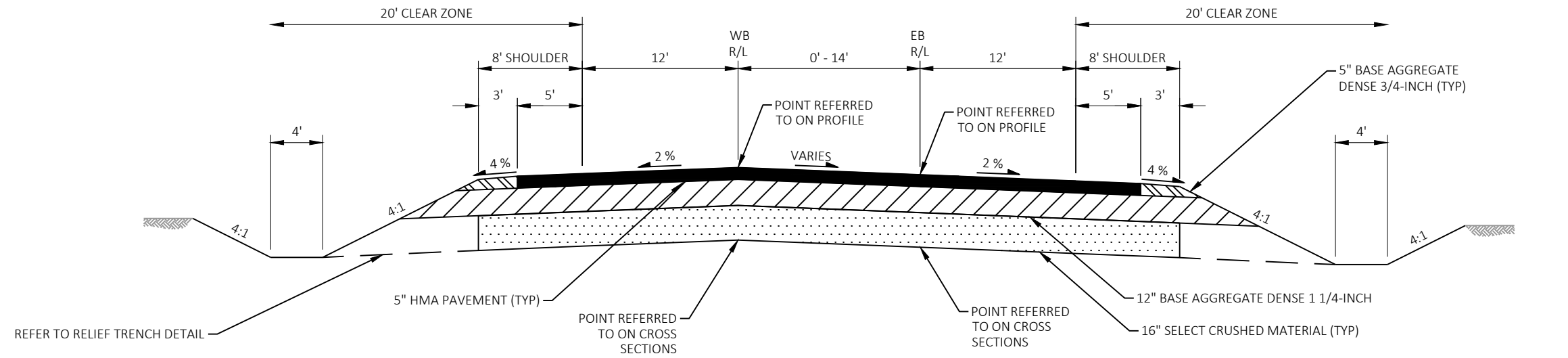

**FINISHED TYPICAL SECTION 7 MILE RD**  
 EB STA 99+93.47 - 111+83.21  
 WB STA 95+64 - 111+84.05

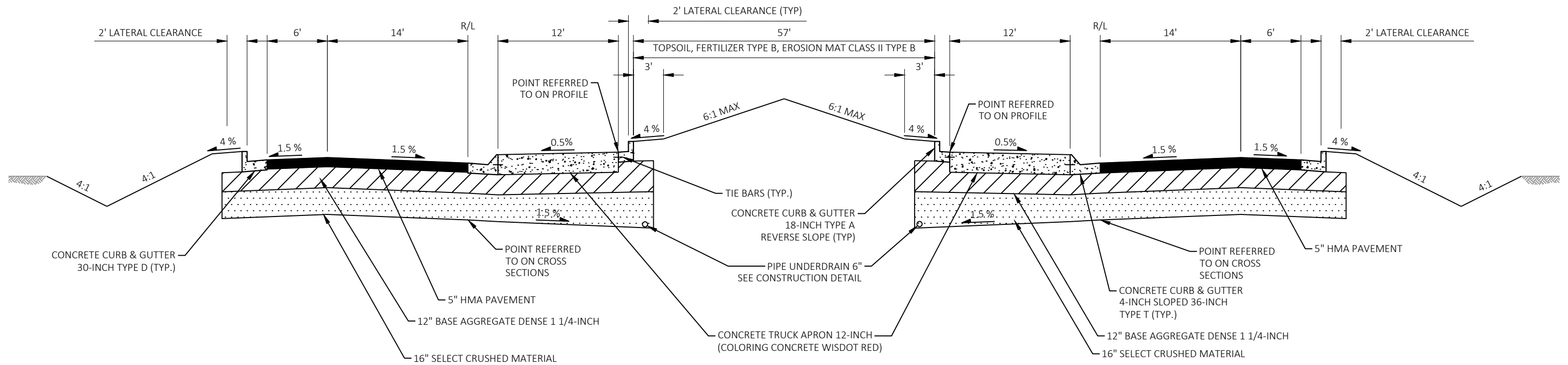

**FINISHED TYPICAL SECTION ROUNDABOUT**  
 STA 1+00-3+74

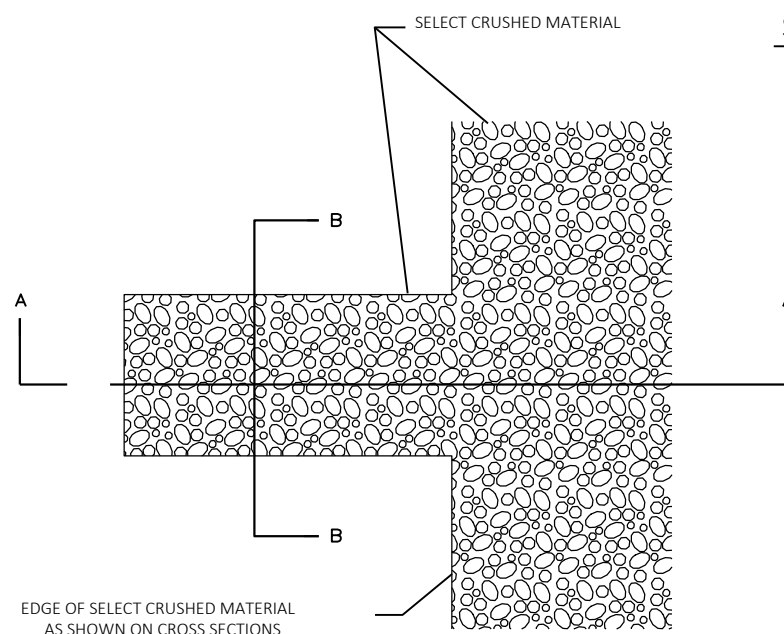
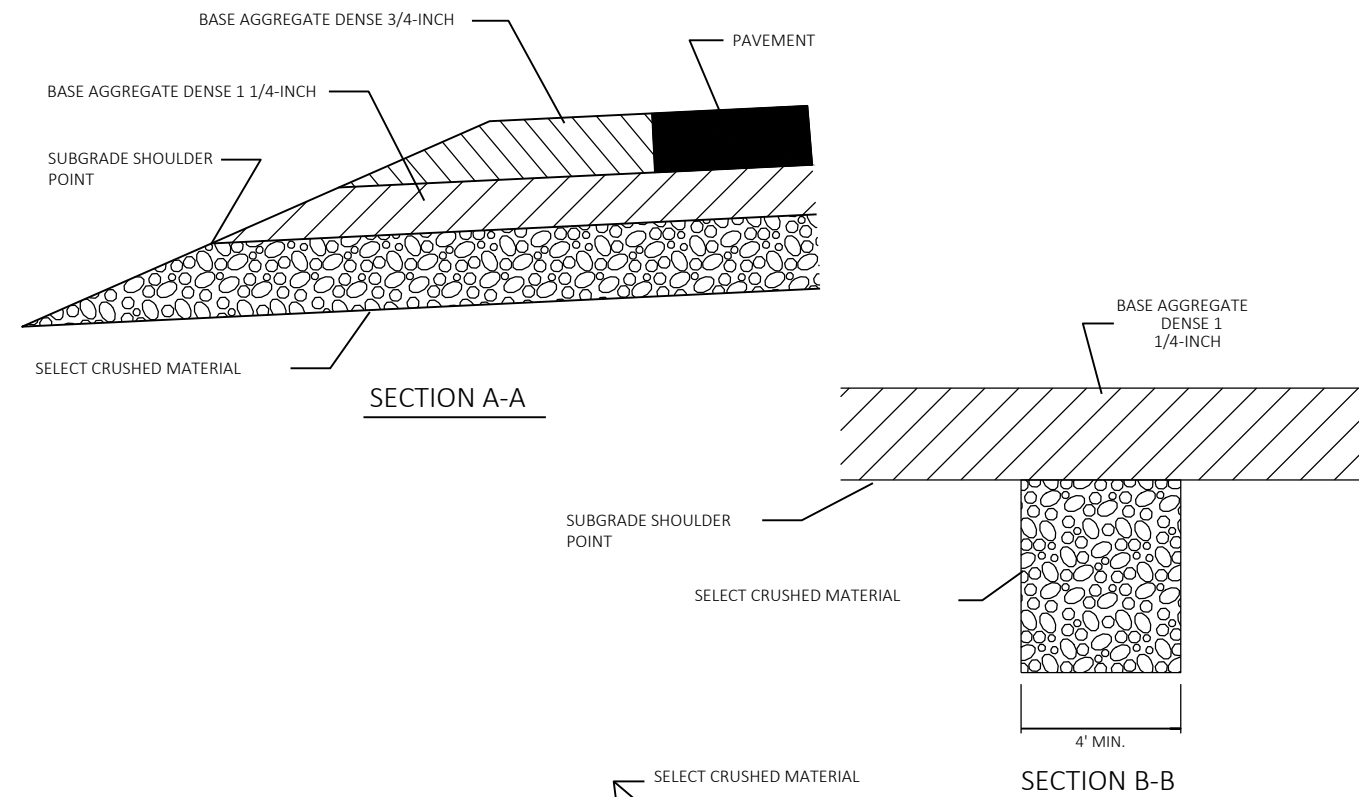

CONSTRUCT DRAINS AT LEAST EVERY 250' AND AT EACH SAG VERTICAL CURVE IN THE PROFILE.

APPROXIMATE LOCATIONS FOR RELIEF TRENCHES:  
 CTH U: 257+50 RT/LT, 260+00 RT/LT, 264+00 RT/LT, 266+50 RT/LT  
 7 MILE ROAD: 101+00 RT/LT, 103+00 RT/LT, 106+50 RT/LT, 108+50 RT/LT

EXCAVATION REQUIRED TO CONSTRUCT RELIEF TRENCH INCLUDED TO THE ITEM SELECT CRUSHED MATERIAL

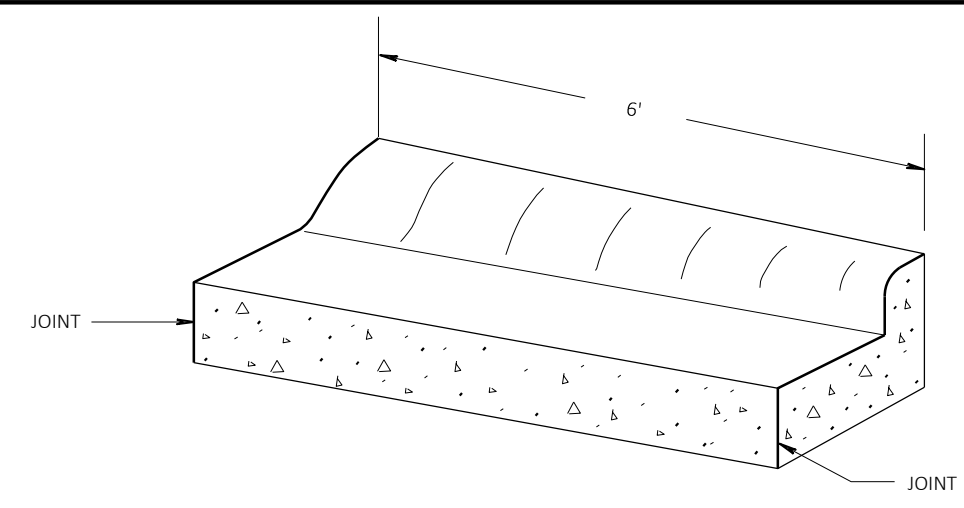

36" TYPE "A" CURB & GUTTER TO 30" TYPE "A" CURB & GUTTER  
 (TO BE MEASURED & PAID FOR AS 36" CONC. C&G)

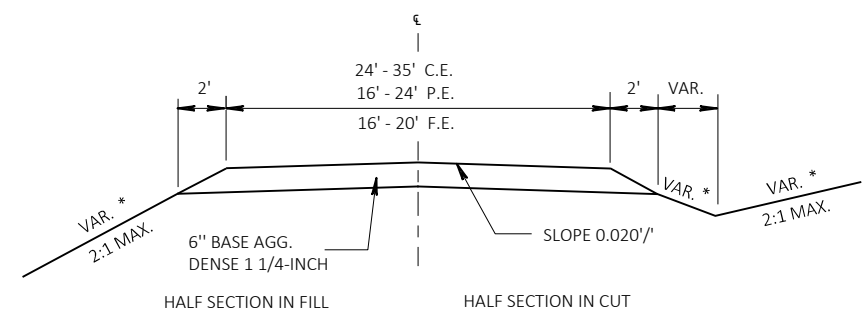
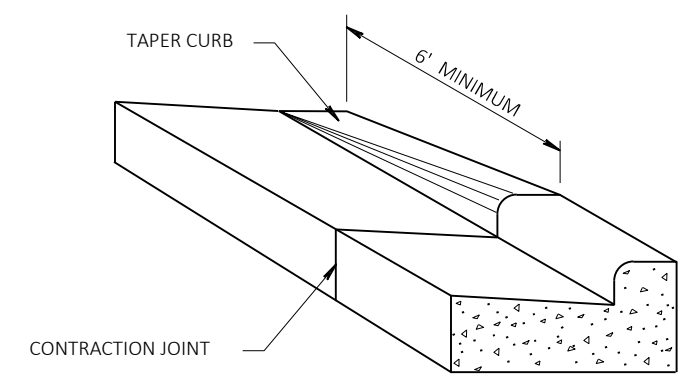

\* 6:1 WITHIN CLEAR ZONE

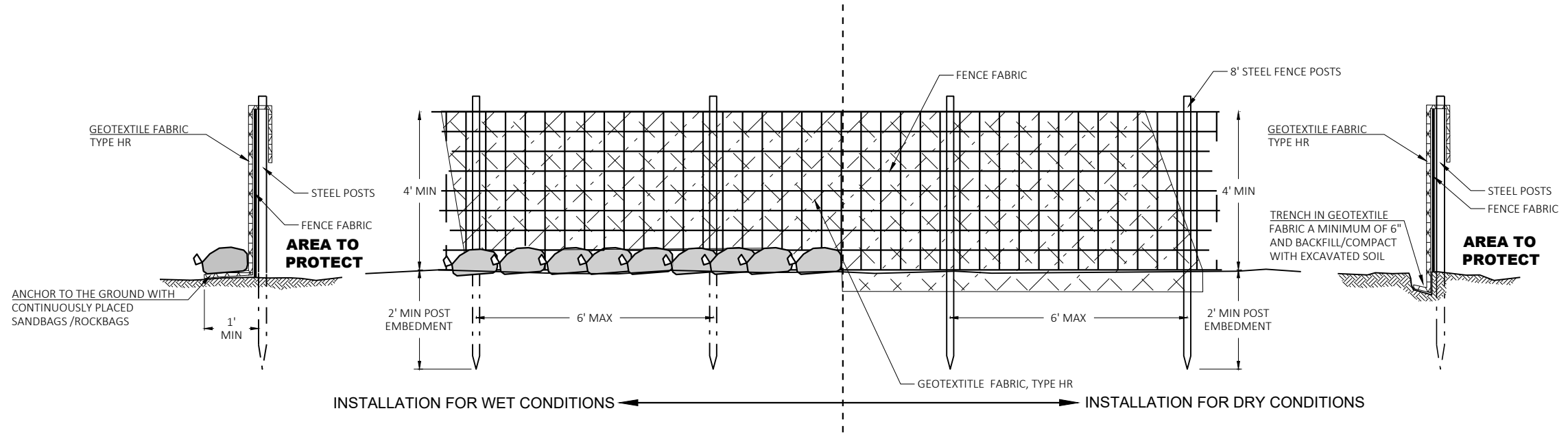

**SILT FENCE HEAVY DUTY**

GENERAL NOTES:

1. ATTACH FENCE FABRIC TO POSTS A MINIMUM OF 3 TIES PER POST (TOP, MIDDLE, BOTTOM)
2. ATTACH GEOTEXTILE FABRIC TO FENCE FABRIC AND/OR POSTS AT A MAXIMUM SPACING OF EVERY 2 FEET ALONG THE TOP AND ADDITIONALLY AS NECESSARY TO PREVENT DISPLACEMENT BY WIND AND WAVE ACTIONS.

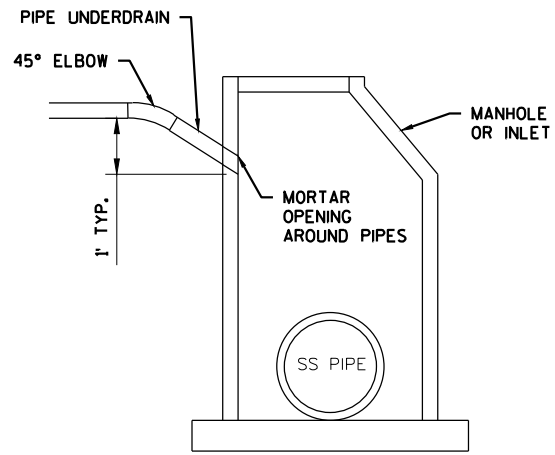

**PIPE UNDERDRAIN CONNECTION TO MANHOLES AND INLETS**

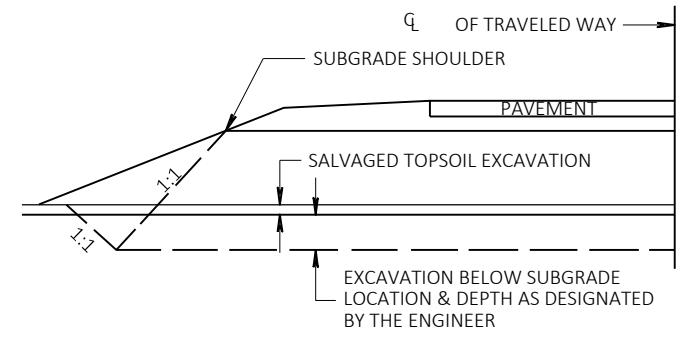

**DETAIL FOR EXCAVATION BELOW SUBGRADE**



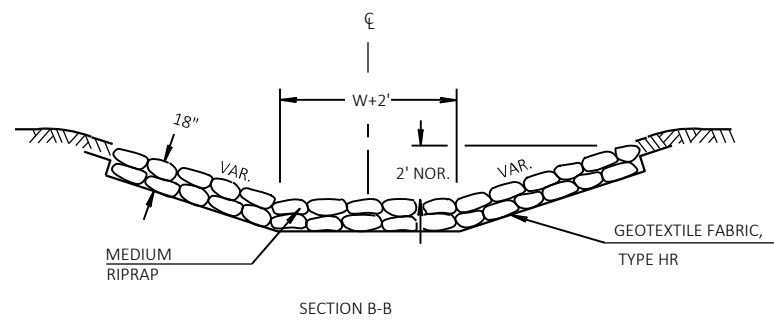
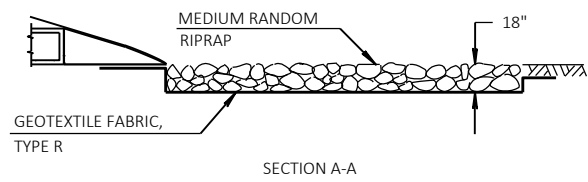
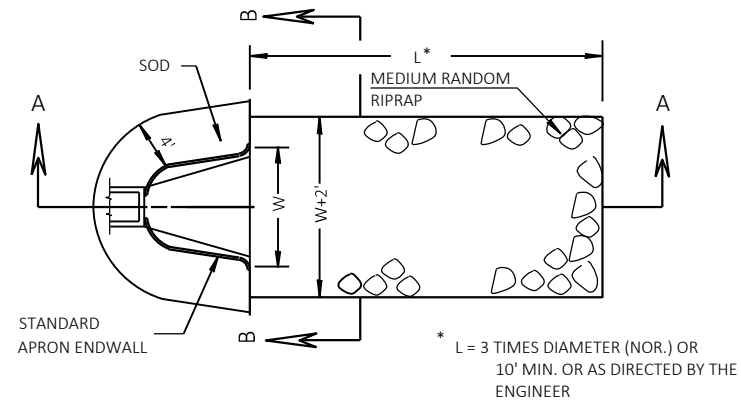

SOD, MEDIUM RIPRAP AND GEOTEXTILE FABRIC DETAIL AT APRON ENDWALL

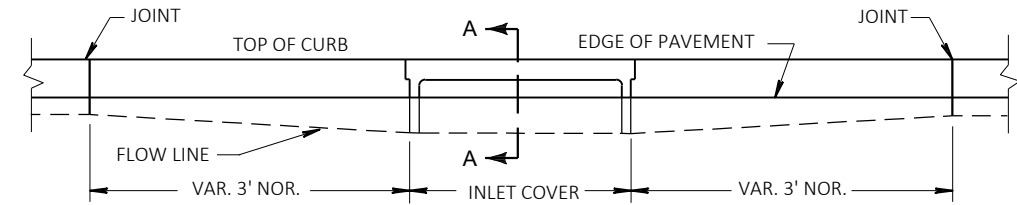

ELEVATION

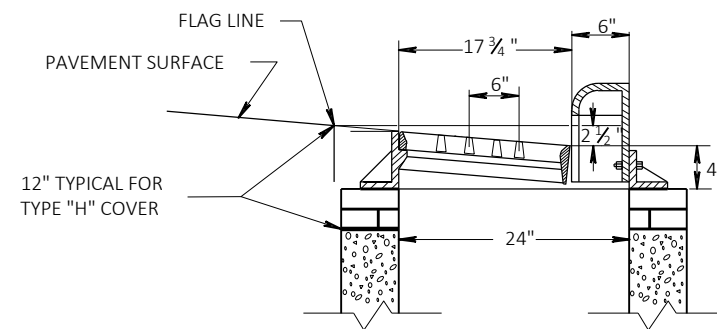
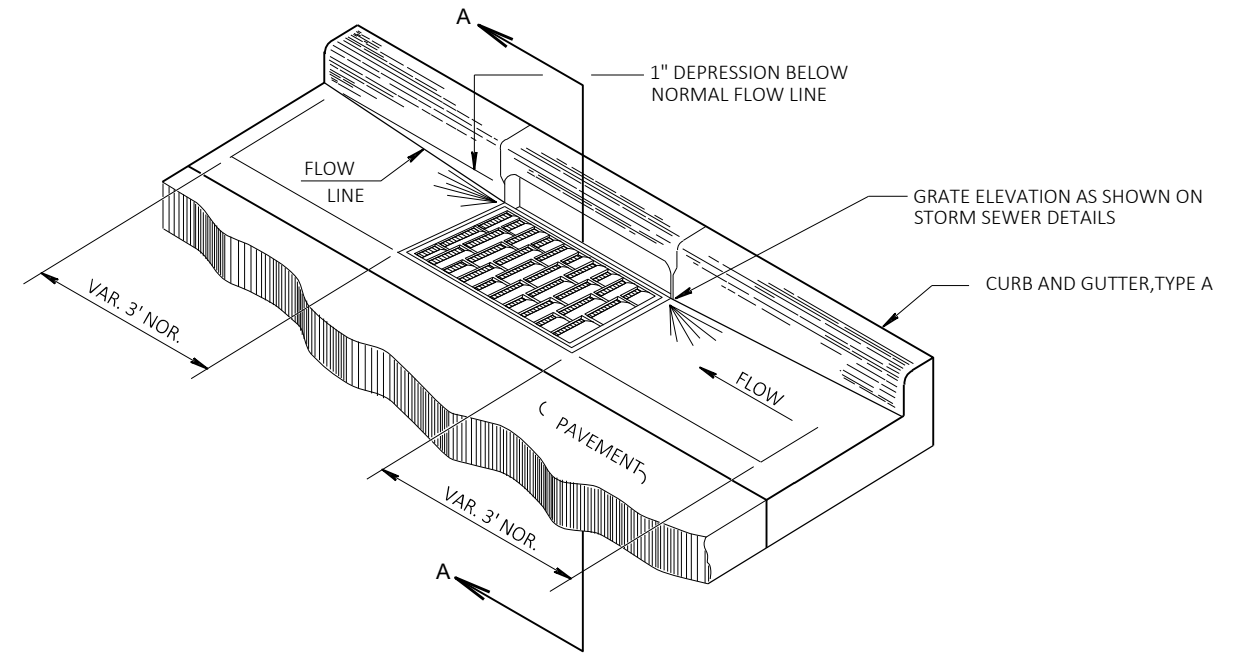

SECTION A-A

DETAIL OF CURB AND GUTTER AT INLETS  
(TYPE 3-H INLET SHOWN)

## RUNOFF COEFFICIENT TABLE

	HYDROLOGIC SOIL GROUP											
	A			B			C			D		
	SLOPE RANGE (PERCENT)			SLOPE RANGE (PERCENT)			SLOPE RANGE (PERCENT)			SLOPE RANGE (PERCENT)		
LAND USE:	0-2	2-6	6 & OVER	0-2	2-6	6 & OVER	0-2	2-6	6 & OVER	0-2	2-6	6 & OVER
ROW CROPS	.08 .22	.16 .30	.22 .38	.12 .26	.20 .34	.27 .44	.15 .30	.24 .37	.33 .50	.19 .34	.28 .41	.38 .56
MEDIAN STRIP-TURF	.19 .24	.20 .26	.24 .30	.19 .25	.22 .28	.26 .33	.20 .26	.23 .30	.30 .37	.20 .27	.25 .32	.30 .40
SIDE SLOPE-TURF			.25 .32			.27 .34			.28 .36			.30 .38
PAVEMENT:												
ASPHALT	.70 - .95											
CONCRETE	.80 - .95											
BRICK	.70 - .80											
DRIVES, WALKS	.75 - .85											
ROOFS	.75 - .95											
GRAVEL ROADS, SHOULDERS	.40 - .60											

TOTAL PROJECT AREA = 9.41 ACRES  
 TOTAL AREA EXPECTED TO BE DISTURBED BY CONSTRUCTION ACTIVITIES = 7.99 ACRES

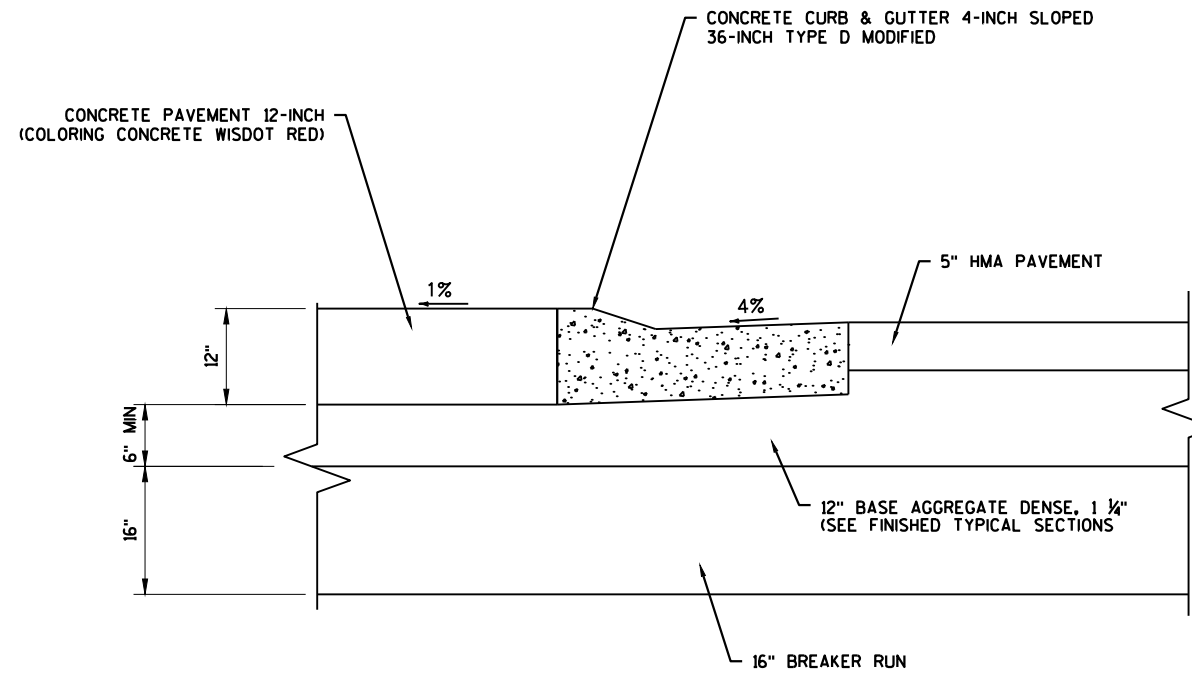

**TRUCK OVERTRACKING PAD DETAIL**  
ALL FOUR QUADRANTS

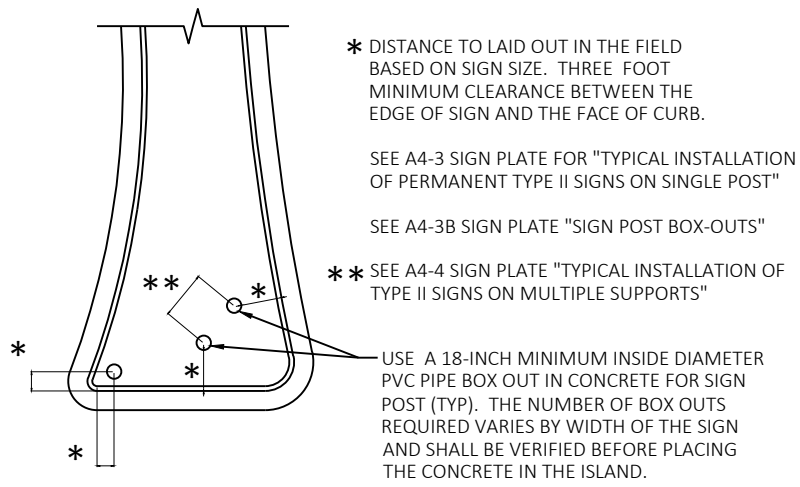

ISLAND SIGN LOCATION DETAIL (TYP)

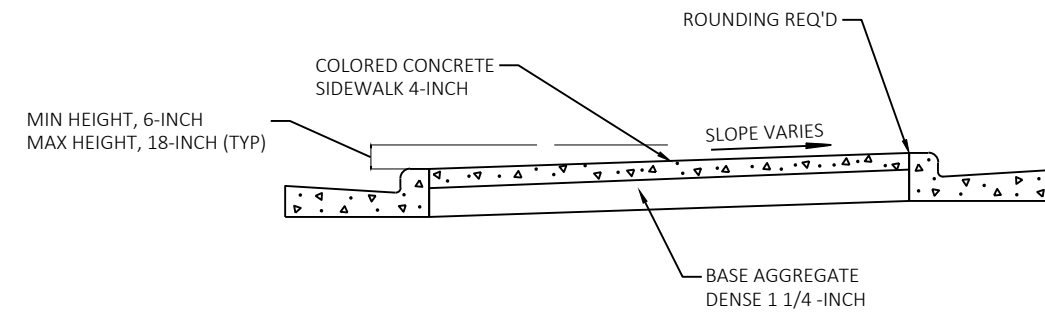

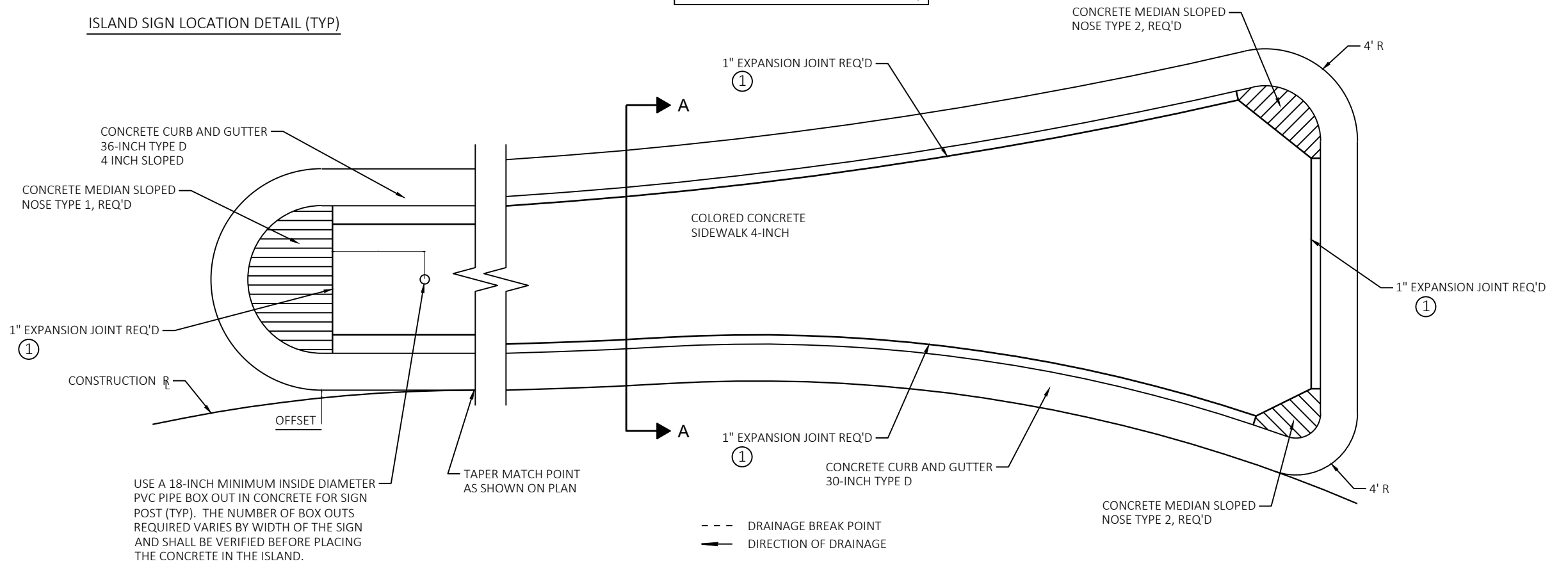

SECTION A-A

① EXPANSION MATERIAL TO BE 1" LONGER THAN ABUTTING MEDIAN CONCRETE THICKNESS. (i.e. 5" IN HEIGHT WHEN ADJACENT TO CONCRETE SIDEWALK 4-INCH)

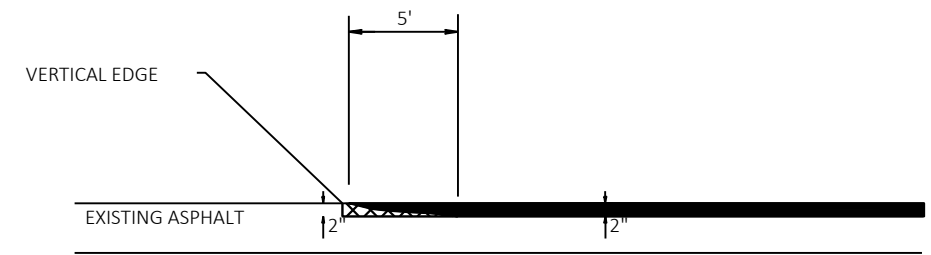
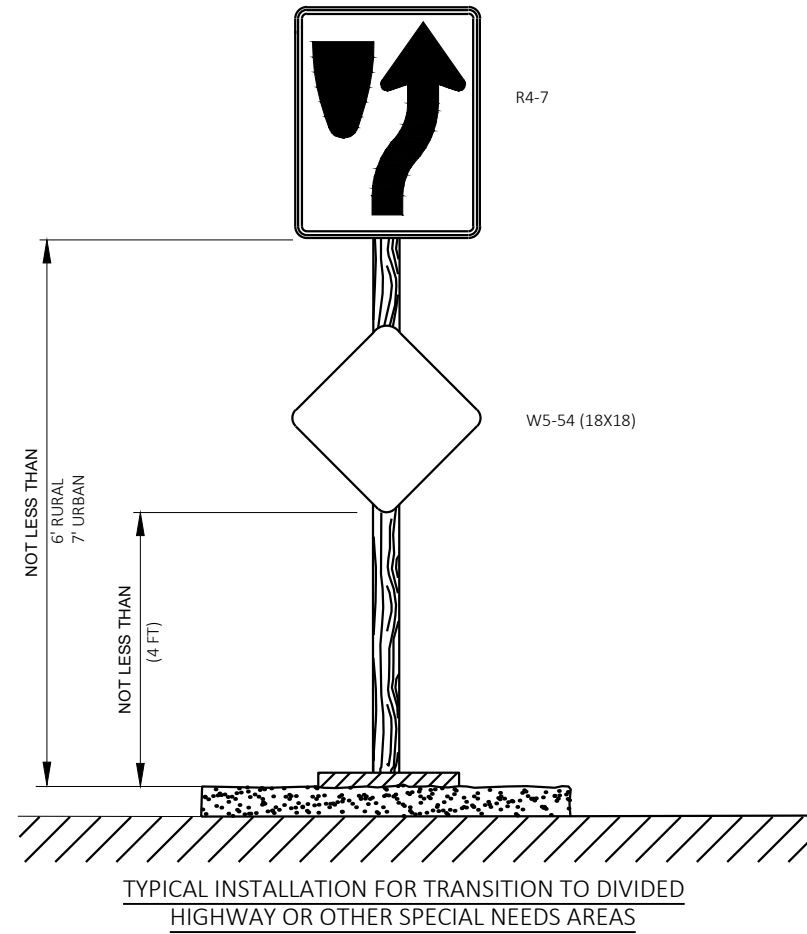

CONCRETE SPLITTER ISLAND DETAIL WITHOUT CROSSWALK



-  REMOVE ASPHALTIC SURFACE WEDGE AT BUTT JOINT TO CREATE VERTICAL EDGE  
PAID UNDER BID ITEM REMOVING ASPHALTIC SURFACE BUTT JOINTS
-  REMOVING ASPHALTIC  
SURFACE MILLING

**BUTT JOINT DETAIL**  
REQUIRED AT STA 100+62 & STA 210+82

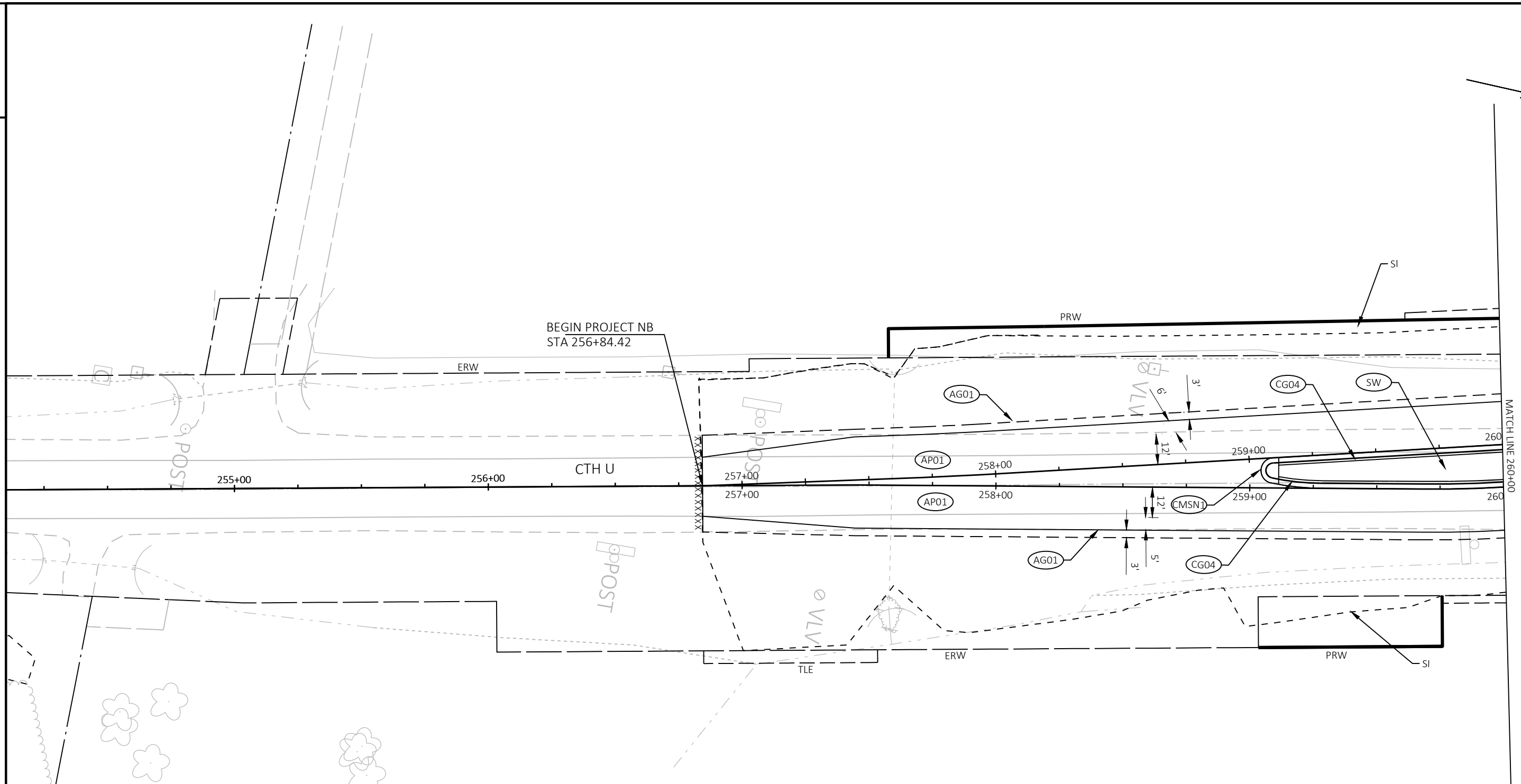

LEGEND	
(AP01) HMA PAVEMENT 4 LT 58-28 S 2" (UPPER LAYER)	(CG04) CONCRETE CURB & GUTTER, 4-INCH SLOPED 36-INCH, TYPE D
(AP02) HMA PAVEMENT 3 LT 58-28 S 3" (LOWER LAYER)	(CG06) CONCRETE CURB & GUTTER, 6-INCH SLOPED 36-INCH, TYPE D
(AP02) HMA PAVEMENT 4 LT 58-28 S 2" (UPPER LAYER) REMOVING ASPHALTIC SURFACE MILLING	(CP01) CONCRETE TRUCK APRON (RED)
(AG01) BASE AGGREGATE DENSE 3/4-INCH	(CMSN1) CONCRETE MEDIAN SLOPED NOSE TYPE 1
(AG02) BASE AGGREGATE DENSE 1 1/4-INCH	(CMSN2) CONCRETE MEDIAN SLOPED NOSE TYPE 2
(CG01) CONCRETE CURB & GUTTER 18-INCH, TYPE , REVERSE SLOPE	(AFL) ASPHALTIC FLUMES
(CG02) CONCRETE CURB & GUTTER 4-INCH SLOPED 36-INCH, TYPE T	(SW) CONCRETE SIDEWALK 4-INCH OVER 4-INCH BASE AGGREGATE DENSE 1 1/4-INCH
(CG03) CONCRETE CURB & GUTTER 30-INCH, TYPE D	.xxxx. SAWING ASPHALT

PROJECT NO: 2816-03-70

HWY: CTH U

COUNTY: RACINE

PLAN DETAILS - CTH U

SHEET

E



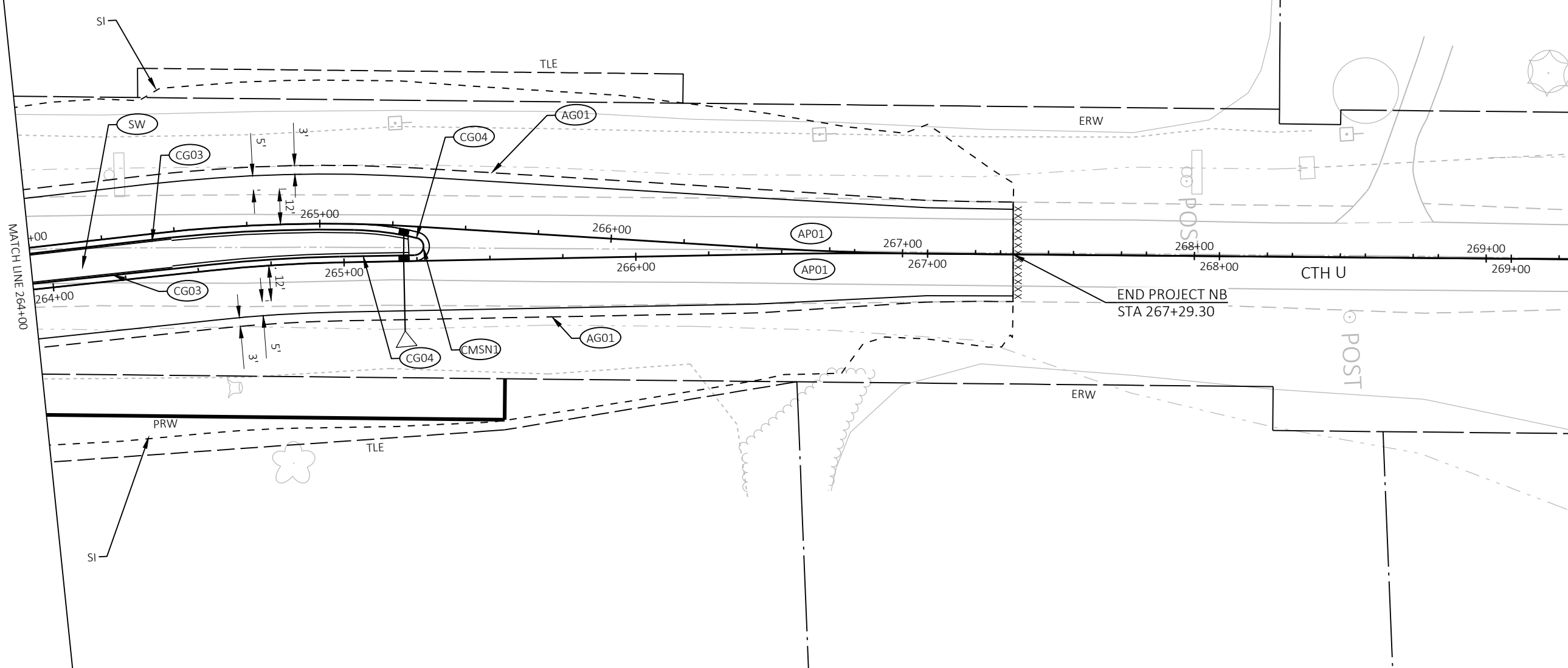

LEGEND	
(AP01) HMA PAVEMENT 4 LT 58-28 S 2" (UPPER LAYER)	(CG04) CONCRETE CURB & GUTTER, 4-INCH SLOPED 36-INCH, TYPE D
(AP02) HMA PAVEMENT 3 LT 58-28 S 3" (LOWER LAYER)	(CG06) CONCRETE CURB & GUTTER, 6-INCH SLOPED 36-INCH, TYPE D
(AP02) HMA PAVEMENT 4 LT 58-28 S 2" (UPPER LAYER)	(CP01) CONCRETE TRUCK APRON (RED)
REMOVING ASPHALTIC SURFACE MILLING	(CMSN1) CONCRETE MEDIAN SLOPED NOSE TYPE 1
(AG01) BASE AGGREGATE DENSE 3/4-INCH	(CMSN2) CONCRETE MEDIAN SLOPED NOSE TYPE 2
(AG02) BASE AGGREGATE DENSE 1 1/4-INCH	(AFL) ASPHALTIC FLUMES
(CG01) CONCRETE CURB & GUTTER 18-INCH, TYPE , REVERSE SLOPE	(SW) CONCRETE SIDEWALK 4-INCH OVER 4-INCH
(CG02) CONCRETE CURB & GUTTER 4-INCH SLOPED 36-INCH, TYPE T	BASE AGGREGATE DENSE 1 1/4-INCH
(CG03) CONCRETE CURB & GUTTER 30-INCH, TYPE D	.XXXX. SAWING ASPHALT

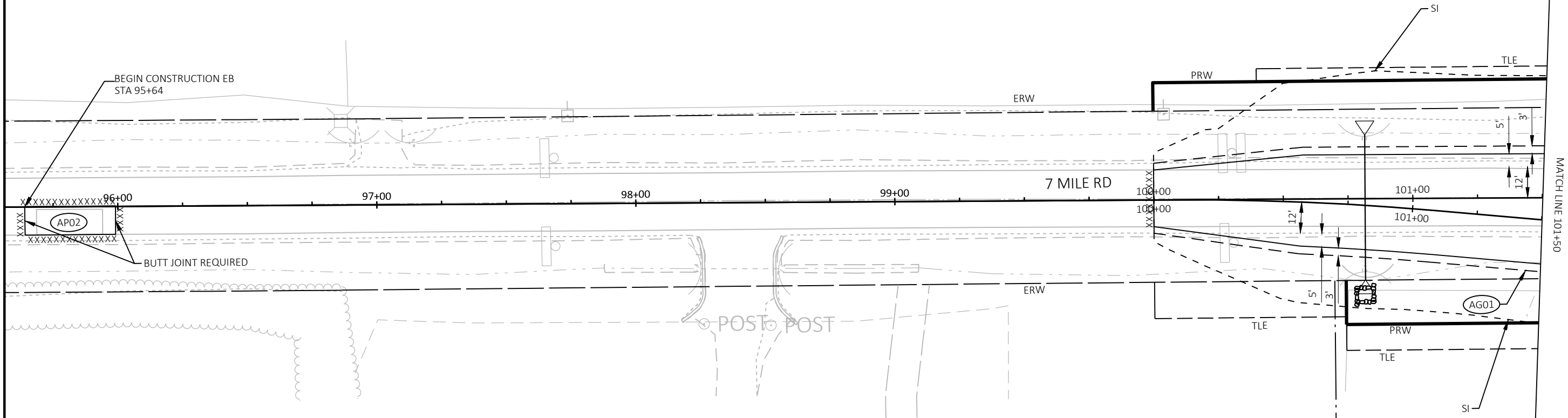

LEGEND	
(AP01) HMA PAVEMENT 4 LT 58-28 S 2" (UPPER LAYER)	(CG04) CONCRETE CURB & GUTTER, 4-INCH SLOPED 36-INCH, TYPE D
(AP02) HMA PAVEMENT 3 LT 58-28 S 3" (LOWER LAYER)	(CG06) CONCRETE CURB & GUTTER, 6-INCH SLOPED 36-INCH, TYPE D
(AP02) HMA PAVEMENT 4 LT 58-28 S 2" (UPPER LAYER)	(CP01) CONCRETE TRUCK APRON (RED)
(AG01) REMOVING ASPHALTIC SURFACE MILLING	(CMSN1) CONCRETE MEDIAN SLOPED NOSE TYPE 1
(AG01) BASE AGGREGATE DENSE 3/4-INCH	(CMSN2) CONCRETE MEDIAN SLOPED NOSE TYPE 2
(AG02) BASE AGGREGATE DENSE 1 1/4-INCH	(AFL) ASPHALTIC FLUMES
(CG01) CONCRETE CURB & GUTTER 18-INCH, TYPE , REVERSE SLOPE	(SW) CONCRETE SIDEWALK 4-INCH OVER 4-INCH
(CG02) CONCRETE CURB & GUTTER 4-INCH SLOPED 36-INCH, TYPE T	.XXXX. SAWING ASPHALT
(CG03) CONCRETE CURB & GUTTER 30-INCH, TYPE D	

PROJECT NO: 2816-03-70

HWY: CTH U

COUNTY: RACINE

PLAN DETAILS - 7 MILE RD

SHEET

E

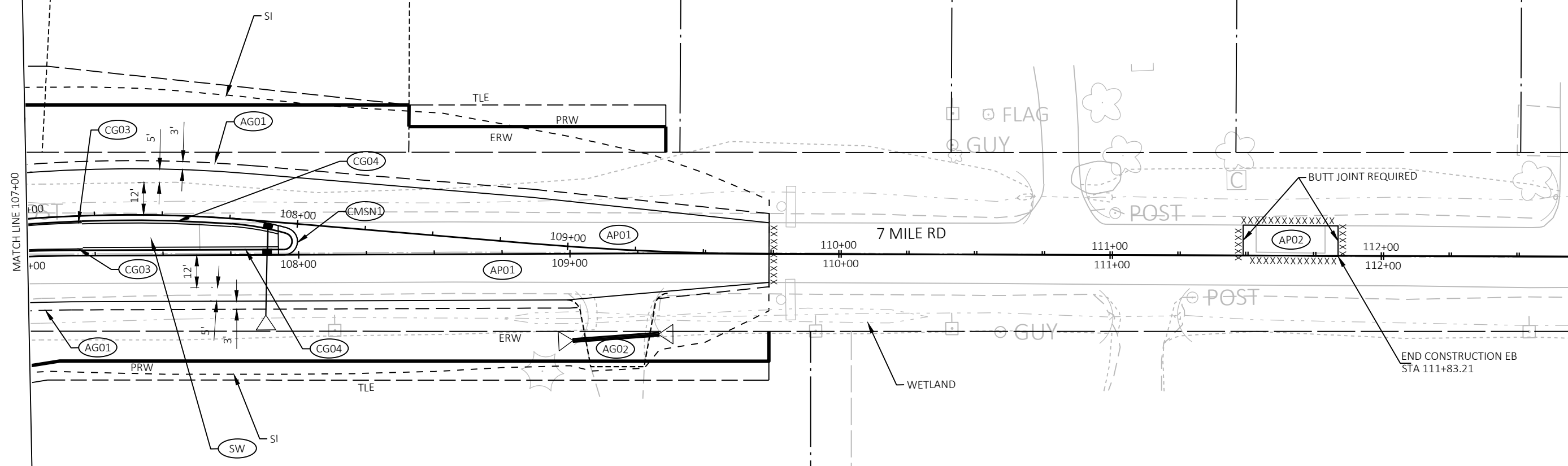

LEGEND	
(AP01) HMA PAVEMENT 4 LT 58-28 S 2" (UPPER LAYER)	(CG04) CONCRETE CURB & GUTTER, 4-INCH SLOPED 36-INCH, TYPE D
(AP01) HMA PAVEMENT 3 LT 58-28 S 3" (LOWER LAYER)	(CG06) CONCRETE CURB & GUTTER, 6-INCH SLOPED 36-INCH, TYPE D
(AP02) HMA PAVEMENT 4 LT 58-28 S 2" (UPPER LAYER)	(CP01) CONCRETE TRUCK APRON (RED)
REMOVING ASPHALTIC SURFACE MILLING	(CMSN1) CONCRETE MEDIAN SLOPED NOSE TYPE 1
(AG01) BASE AGGREGATE DENSE 3/4-INCH	(CMSN2) CONCRETE MEDIAN SLOPED NOSE TYPE 2
(AG02) BASE AGGREGATE DENSE 1 1/4-INCH	(AFL) ASPHALTIC FLUMES
(CG01) CONCRETE CURB & GUTTER 18-INCH, TYPE , REVERSE SLOPE	(SW) CONCRETE SIDEWALK 4-INCH OVER 4-INCH
(CG02) CONCRETE CURB & GUTTER 4-INCH SLOPED 36-INCH, TYPE T	BASE AGGREGATE DENSE 1 1/4-INCH
(CG03) CONCRETE CURB & GUTTER 30-INCH, TYPE D	.XXXX. SAWING ASPHALT

LEGEND

- AP01 HMA PAVEMENT 4 LT 58-28 S 2" (UPPER LAYER)
- AP02 HMA PAVEMENT 3 LT 58-28 S 3" (LOWER LAYER)
- AP02 HMA PAVEMENT 4 LT 58-28 S 2" (UPPER LAYER)
- AG01 REMOVING ASPHALTIC SURFACE MILLING
- AG01 BASE AGGREGATE DENSE 3/4-INCH
- AG02 BASE AGGREGATE DENSE 1 1/4-INCH
- CG01 CONCRETE CURB & GUTTER 18-INCH, TYPE , REVERSE SLOPE
- CG02 CONCRETE CURB & GUTTER 4-INCH SLOPED 36-INCH, TYPE T
- CG03 CONCRETE CURB & GUTTER 30-INCH, TYPE D
- CG04 CONCRETE CURB & GUTTER, 4-INCH SLOPED 36-INCH, TYPE D
- CG06 CONCRETE CURB & GUTTER, 6-INCH SLOPED 36-INCH, TYPE D
- CP01 CONCRETE TRUCK APRON (RED)
- CMSN1 CONCRETE MEDIAN SLOPED NOSE TYPE 1
- CMSN2 CONCRETE MEDIAN SLOPED NOSE TYPE 2
- AFL ASPHALTIC FLUMES
- SW CONCRETE SIDEWALK 4-INCH OVER 4-INCH BASE AGGREGATE DENSE 1 1/4-INCH
- .XXXX SAWING ASPHALT

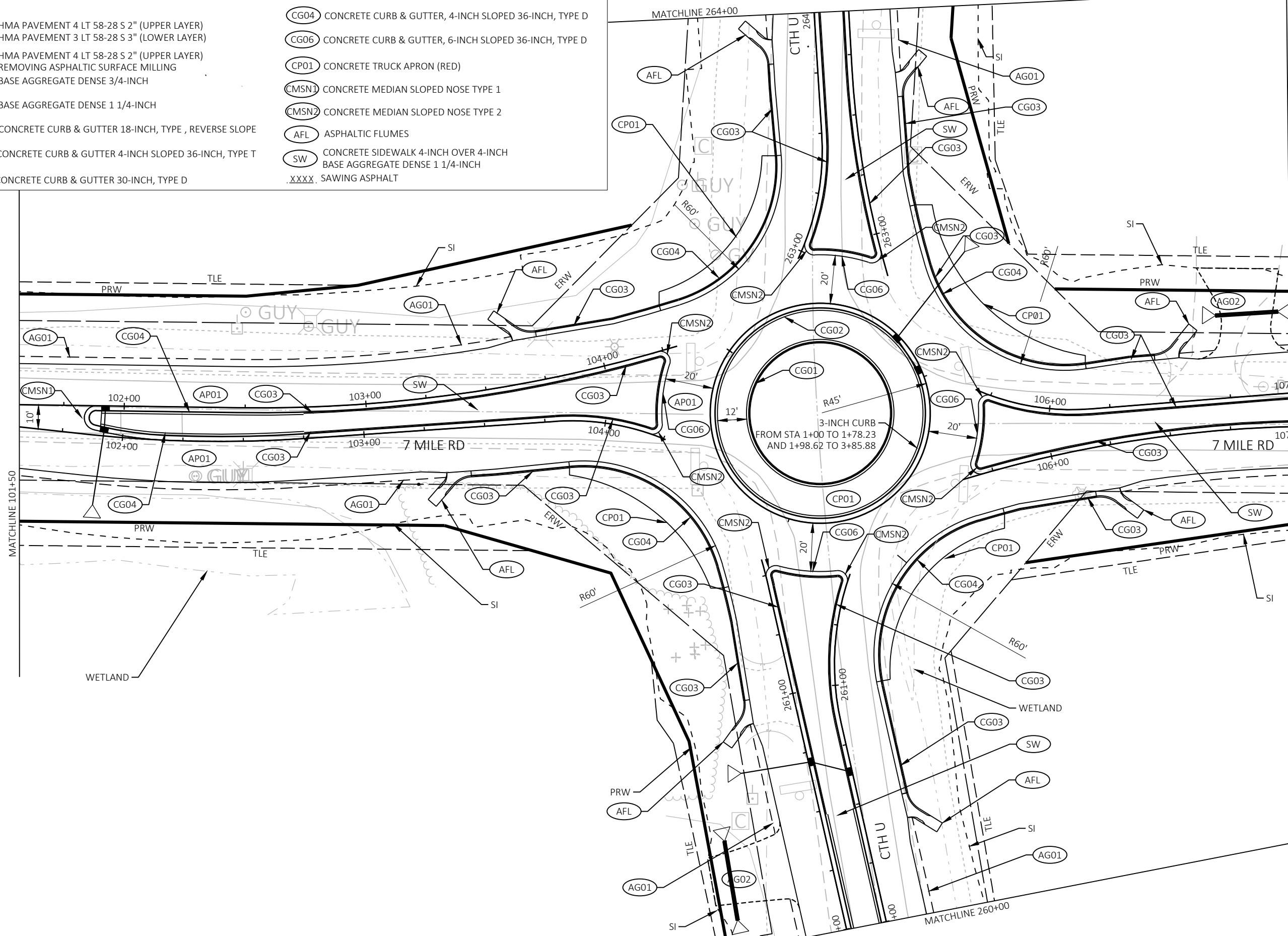



BEGIN PROJECT NB  
STA 256+84.42

256+00

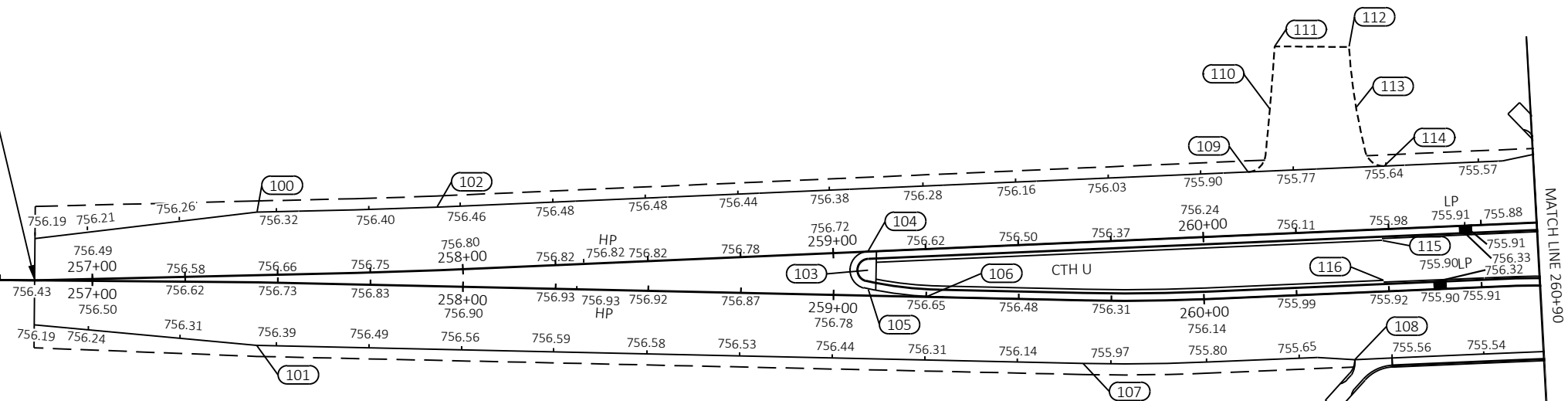

DATA TABLE

POINT NUMBER	STATION	OFFSET	ELEVATION	NORTHING	EASTING
100	257+44.23	18.90' LT	756.31	223108.33	579355.98
101	257+44.68	17.00' RT	756.36	223114.70	579391.31
102	257+92.51	21.29' LT	756.45	223155.87	579345.94
103	259+09.32	6.87' LT	756.72	223273.49	579341.71
104	259+08.99	11.86' LT	756.68	223272.38	579336.83
105	259+09.29	1.78' LT	756.74	223274.26	579346.74
106	259+25.00	0.00'	756.65	223290.06	579346.01
107	259+67.72	17.00' RT	756.02	223334.92	579356.05
108	260+39.93	18.07' RT	755.58	223406.87	579341.93
109	260+13.30	33.75' LT	755.83	223369.42	579297.29
110	260+19.95	50.49' LT	751.97	223372.20	579279.49
111	260+21.97	67.27' LT	750.77	223370.45	579262.69
112	260+41.97	66.24' LT	751.36	223390.18	579259.26
113	260+43.20	49.89' LT	751.98	223395.00	579274.93
114	260+50.11	33.78' LT	755.64	223405.31	579289.11
115	260+48.66	13.77' LT	756.25	223408.33	579308.94
116	260+48.62	3.00' LT	756.31	223410.68	579319.45



DATA TABLE					
POINT NUMBER	STATION	OFFSET	ELEVATION	NORTHING	EASTING
165	264+54.11	17.00' RT	752.53	223802.40	579331.24
166	264+41.33	3.00' LT	753.46	223788.53	579311.98
167	264+41.94	11.69' LT	753.24	223788.66	579303.27
168	264+36.58	31.68' LT	752.73	223782.21	579283.61
169	265+26.40	28.73' LT	751.40	223874.62	579285.91
170	265+22.04	10.67' LT	751.81	223869.70	579303.82
171	265+13.32	12.24' LT	751.92	223861.03	579301.98
172	265+24.64	5.29' LT	751.78	223872.13	579309.28
173	265+25.00	0.00'	751.80	223872.32	579314.58
174	264+98.55	17.00' RT	751.86	223845.35	579330.73
175	266+41.19	17.00' RT	749.69	223987.91	579335.25
176	266+42.57	19.31' LT	749.67	223990.44	579299.01

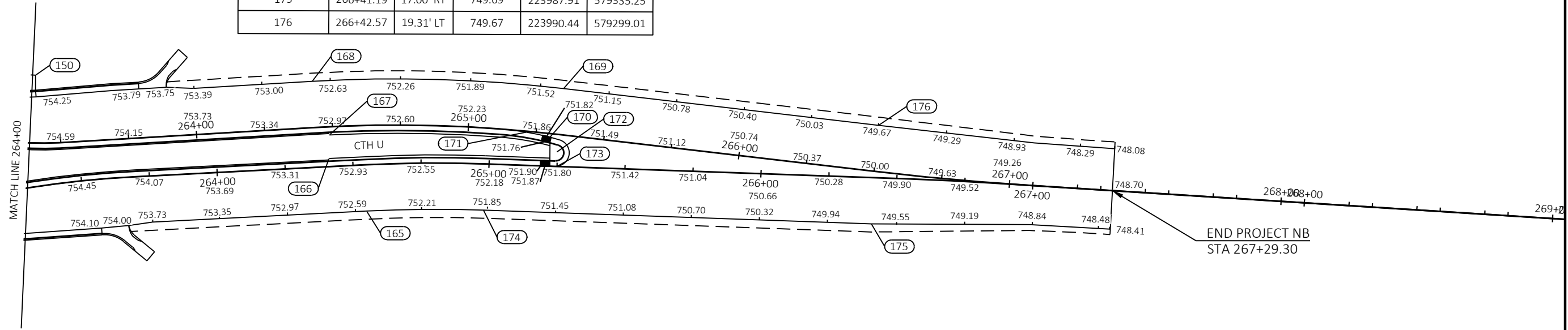

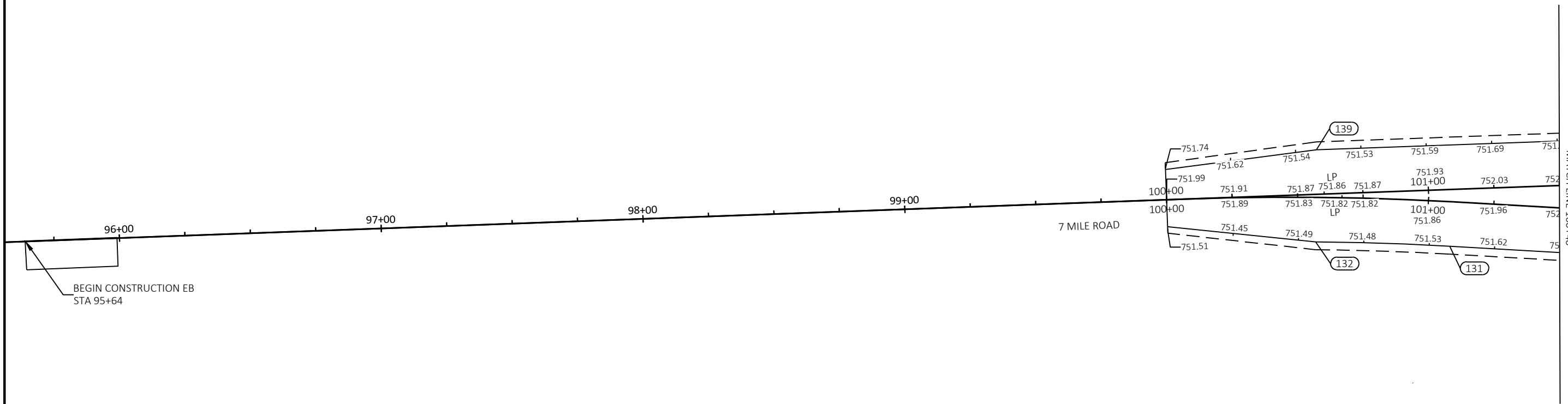

PROJECT NO: 2816-03-70	HWY: CTH U	COUNTY: RACINE	PAVING DETAILS	SHEET	<b>E</b>
------------------------	------------	----------------	----------------	-------	----------

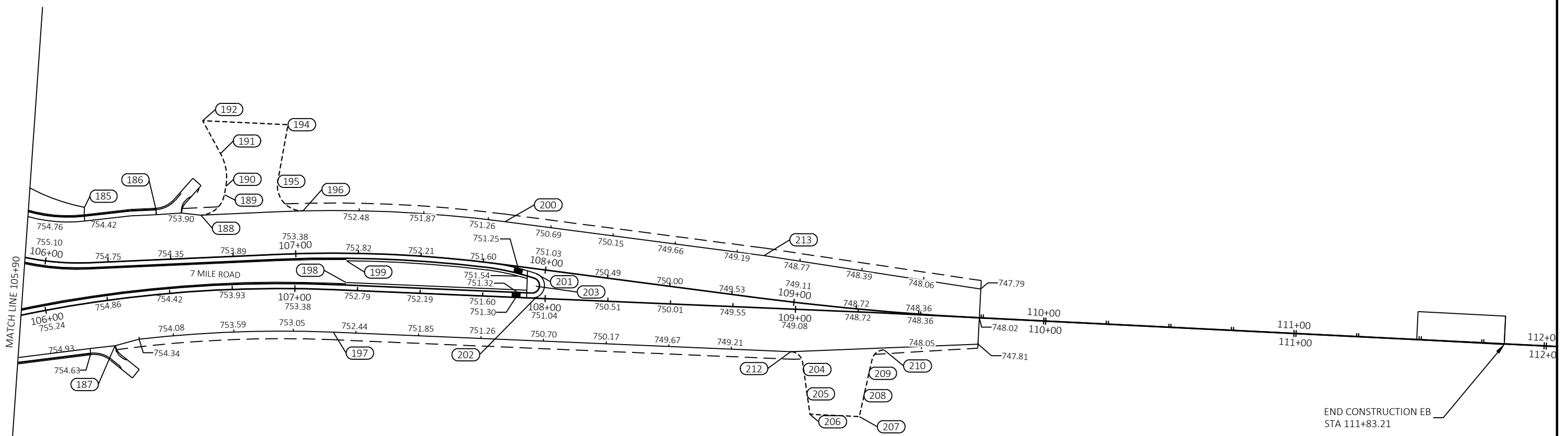

DATA TABLE					
POINT NUMBER	STATION	OFFSET	ELEVATION	NORTHING	EASTING
185	262+32.03	66.73' RT	0.00	223598.00	579415.47
186	262+30.08	94.81' RT	754.00	223598.09	579444.05
187	262+11.16	82.13' RT	754.49	223543.26	579429.66
188	262+28.75	112.33' RT	753.78	223596.53	579462.03
189	262+30.68	122.69' RT	753.71	223605.04	579471.13
190	262+31.51	123.77' RT	753.73	223608.28	579471.59
191	262+35.08	124.40' RT	0.00	223621.33	579469.01
192	262+39.03	121.29' RT	0.00	223634.20	579461.40
194	262+36.14	153.38' RT	0.00	223633.84	579495.50
195	262+31.18	144.54' RT	0.00	223611.11	579492.21
196	262+28.14	153.04' RT	752.97	223599.69	579502.70
197	262+17.46	166.43' RT	752.66	223551.75	579516.55
198	262+21.76	169.73' RT	753.31	223571.72	579521.02
199	262+23.61	169.55' RT	753.18	223580.45	579520.77
200	262+26.22	233.17' RT	751.11	223598.28	579583.43

DATA TABLE					
POINT NUMBER	STATION	OFFSET	ELEVATION	NORTHING	EASTING
201	262+22.87	245.34' RT	751.03	223578.01	579596.62
202	262+21.35	245.37' RT	751.13	223568.26	579596.62
203	262+22.09	245.19' RT	751.15	223573.00	579596.50
204	262+18.80	354.32' RT	747.53	223543.67	579704.47
205	262+17.72	357.07' RT	745.98	223533.97	579706.38
206	262+16.83	359.38' RT	0.00	223525.89	579707.81
207	262+17.06	378.98' RT	747.47	223525.69	579727.52
208	262+17.97	379.73' RT	746.62	223534.06	579729.15
209	262+18.95	380.61' RT	746.39	223543.06	579730.79
210	262+20.00	385.65' RT	748.25	223552.63	579736.42
212	262+19.55	348.69' RT	748.80	223550.58	579699.29
213	262+23.98	336.17' RT	749.01	223588.47	579687.21

DATA TABLE					
POINT NUMBER	STATION	OFFSET	ELEVATION	NORTHING	EASTING
117	261+00.79	22.85' RT	755.87	223464.10	579334.83
118	261+66.30	30.07' RT	755.92	223510.35	579352.48
119	261+96.88	44.42' RT	755.15	223526.50	579382.10
120	262+01.80	46.35' RT	755.59	223534.18	579388.52
121	261+42.67	4.00' LT	756.65	223504.99	579313.10
122	261+38.12	29.23' LT	756.32	223507.10	579287.42
123	260+90.06	35.62' LT	755.54	223445.73	579278.24
124	261+20.73	43.69' LT	756.24	223487.06	579268.96
125	261+29.94	54.32' LT	756.17	223501.79	579260.43
126	261+44.53	82.81' LT	756.33	223531.93	579239.00

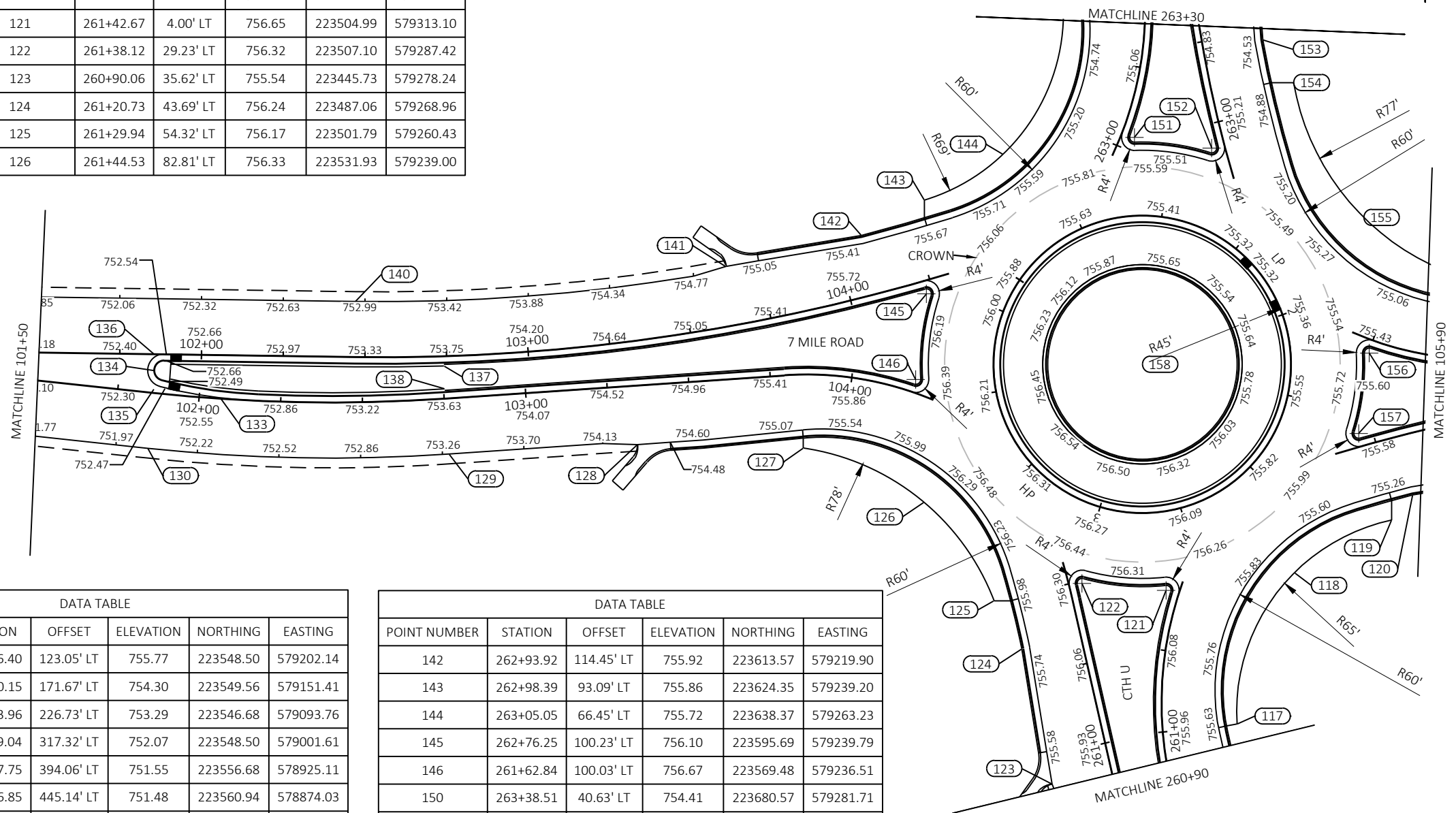

DATA TABLE					
POINT NUMBER	STATION	OFFSET	ELEVATION	NORTHING	EASTING
127	261+46.40	123.05' LT	755.77	223548.50	579202.14
128	261+40.15	171.67' LT	754.30	223549.56	579151.41
129	261+33.96	226.73' LT	753.29	223546.68	579093.76
130	261+29.04	317.32' LT	752.07	223548.50	579001.61
131	261+27.75	394.06' LT	751.55	223556.68	578925.11
132	261+26.85	445.14' LT	751.48	223560.94	578874.03
133	261+34.14	298.49' LT	752.63	223563.58	579024.01
134	261+35.11	320.36' LT	752.47	223572.25	579003.59
135	261+33.70	319.16' LT	752.42	223566.64	579003.50
136	261+36.34	321.58' LT	752.51	223577.22	579003.57
137	261+42.21	235.31' LT	753.99	223573.61	579092.20
138	261+40.09	233.10' LT	754.03	223566.64	579092.40
139	261+33.73	449.89' LT	751.52	223596.06	578876.13
140	261+45.35	267.21' LT	752.95	223593.37	579065.12
141	262+94.80	156.97' LT	754.90	223604.05	579178.44

DATA TABLE					
POINT NUMBER	STATION	OFFSET	ELEVATION	NORTHING	EASTING
142	262+93.92	114.45' LT	755.92	223613.57	579219.90
143	262+98.39	93.09' LT	755.86	223624.35	579239.20
144	263+05.05	66.45' LT	755.72	223638.37	579263.23
145	262+76.25	100.23' LT	756.10	223595.69	579239.79
146	261+62.84	100.03' LT	756.67	223569.48	579236.51
150	263+38.51	40.63' LT	754.41	223680.57	579281.71
151	263+01.37	26.14' LT	755.95	223643.57	579303.42
152	262+92.76	4.00' LT	755.80	223640.29	579327.07
153	263+22.25	18.50' RT	754.97	223673.41	579342.73
154	263+06.65	25.12' RT	754.91	223660.32	579352.14
155	262+57.11	34.07' RT	755.32	223619.06	579373.62
156	262+24.55	24.05' RT	755.90	223577.60	579375.27
157	262+08.23	24.04' RT	0.00	223553.00	579372.07
158	262+25.74	45.45' LT	0.00	223574.11	579305.86

LEGEND

- ##### EROSION MAT CLASS I, TYPE B
- ▨▨▨▨▨ EROSION MAT CLASS II TYPE B
- SILT FENCE
- SILT FENCE HEAVY DUTY
- RIP RAP
- - - - SLOPE INTERCEPT
- ⊗ A ⊙ D INLET PROTECTION TYPE A & D
- △△△ TEMPORARY DITCH CHECK
- CULVERT PIPE CHECK
- ~> SURFACE WATER FLOW

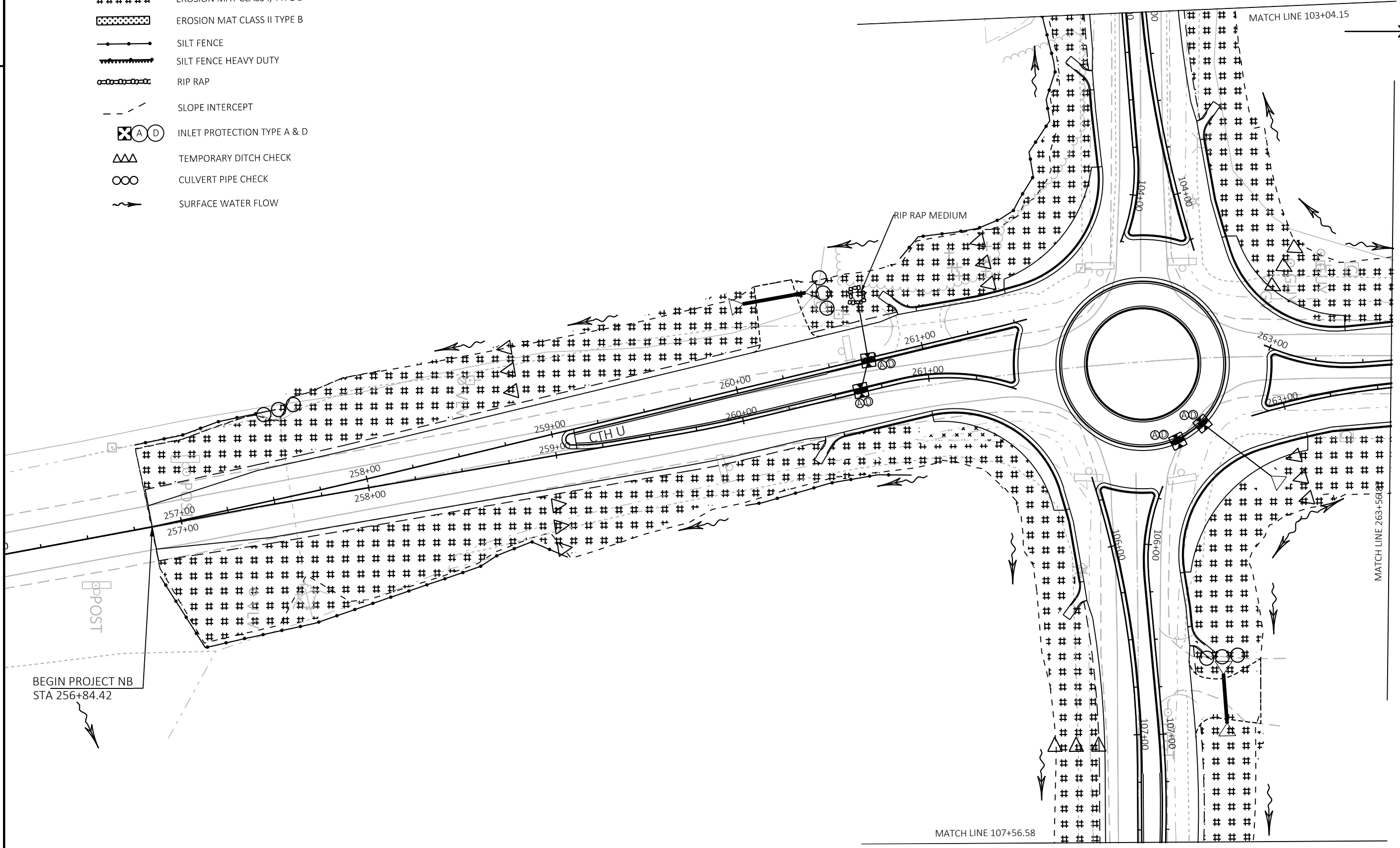

PROJECT NO: 2816-03-70	HWY: CTH U	COUNTY: RACINE	EROSION CONTROL
SHEET			<b>E</b>

LEGEND

- ##### EROSION MAT CLASS I, TYPE B
- ▣▣▣▣▣▣ EROSION MAT CLASS II TYPE B
- SILT FENCE
- ~~~~~ SILT FENCE HEAVY DUTY
- RIP RAP
- - - SLOPE INTERCEPT
- ⊗ A ⊙ D INLET PROTECTION TYPE A & D
- △△△ TEMPORARY DITCH CHECK
- CULVERT PIPE CHECK
- ~> SURFACE WATER FLOW

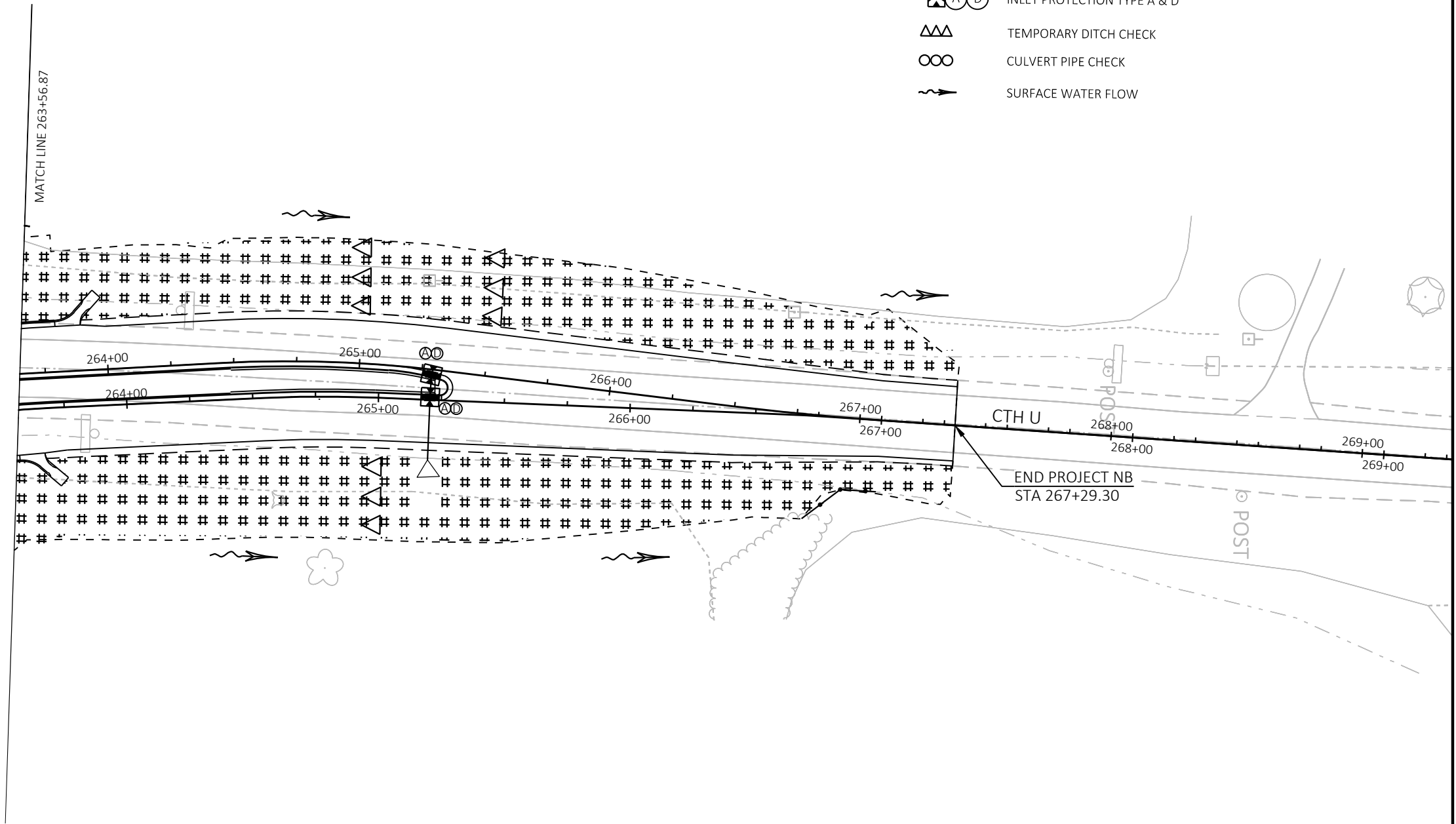

PROJECT NO: 2816-03-70	HWY: CTH U	COUNTY: RACINE	EROSION CONTROL	SHEET	E
------------------------	------------	----------------	-----------------	-------	---

LEGEND

- ##### EROSION MAT CLASS I, TYPE B
- ▢▢▢▢▢▢▢▢▢▢ EROSION MAT CLASS II TYPE B
- SILT FENCE
- ~~~~~ SILT FENCE HEAVY DUTY
- RIP RAP
- - - - - SLOPE INTERCEPT
- ⊗ A ⊙ D INLET PROTECTION TYPE A & D
- △△△ TEMPORARY DITCH CHECK
- CULVERT PIPE CHECK
- ~~~~~> SURFACE WATER FLOW

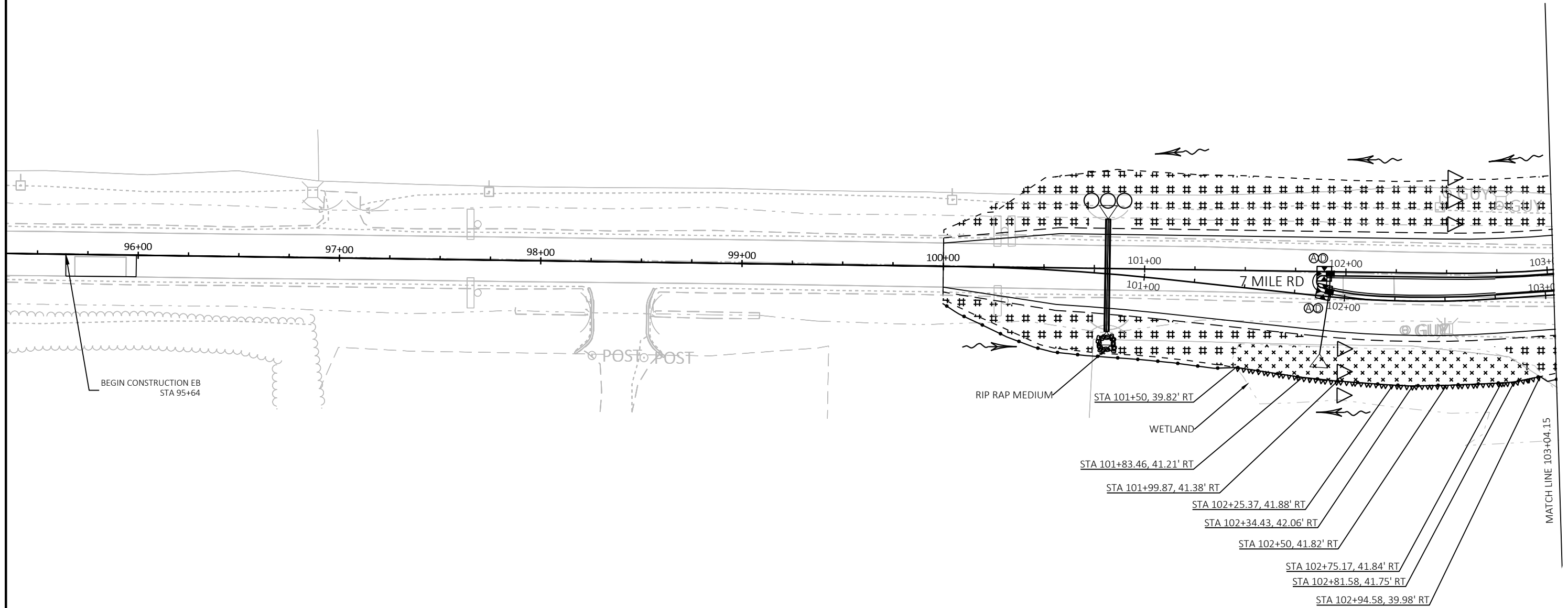

LEGEND

- ##### EROSION MAT CLASS I, TYPE B
- ▣▣▣▣▣ EROSION MAT CLASS II TYPE B
- SILT FENCE
- SILT FENCE HEAVY DUTY
- RIP RAP
- - - SLOPE INTERCEPT
- ⊗ A ⊙ D INLET PROTECTION TYPE A & D
- △△△ TEMPORARY DITCH CHECK
- CULVERT PIPE CHECK
- ~> SURFACE WATER FLOW





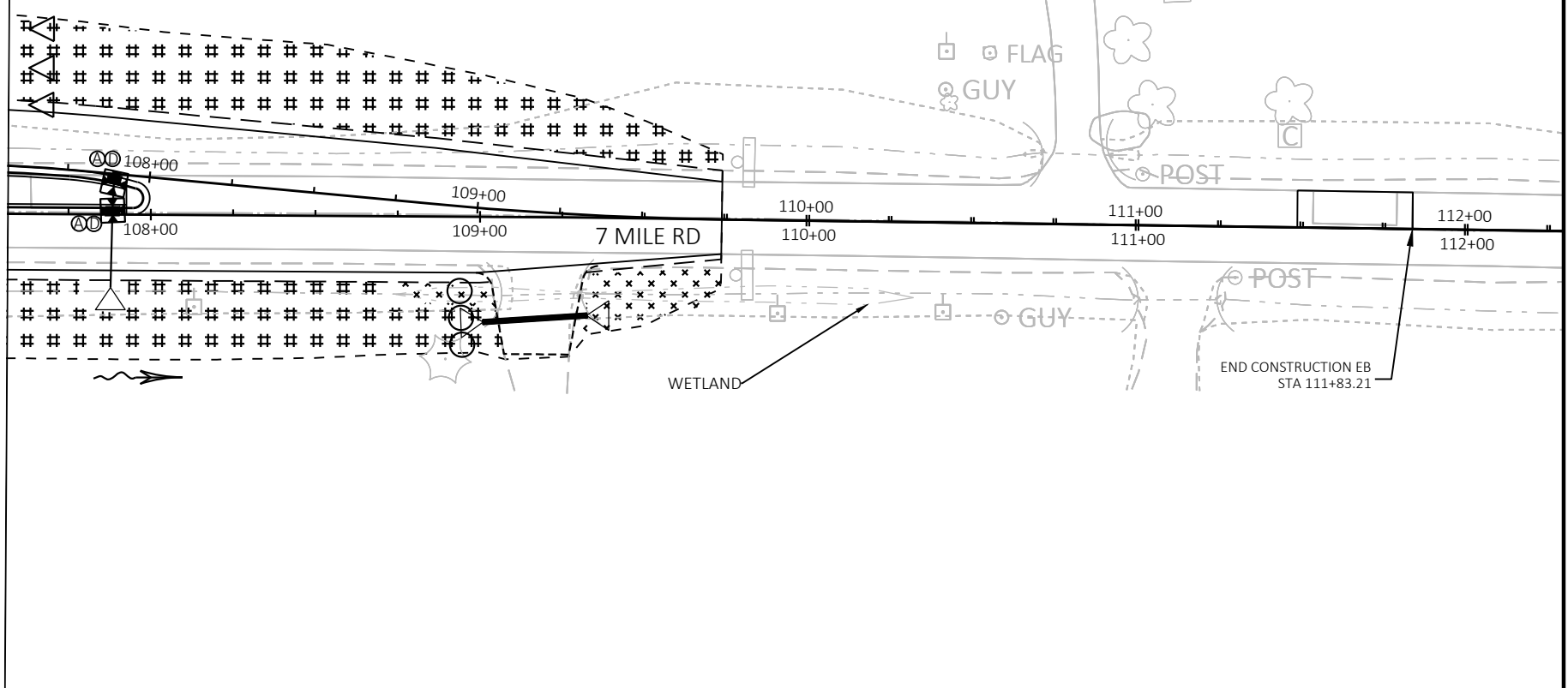

MATCH LINE 107+56.58

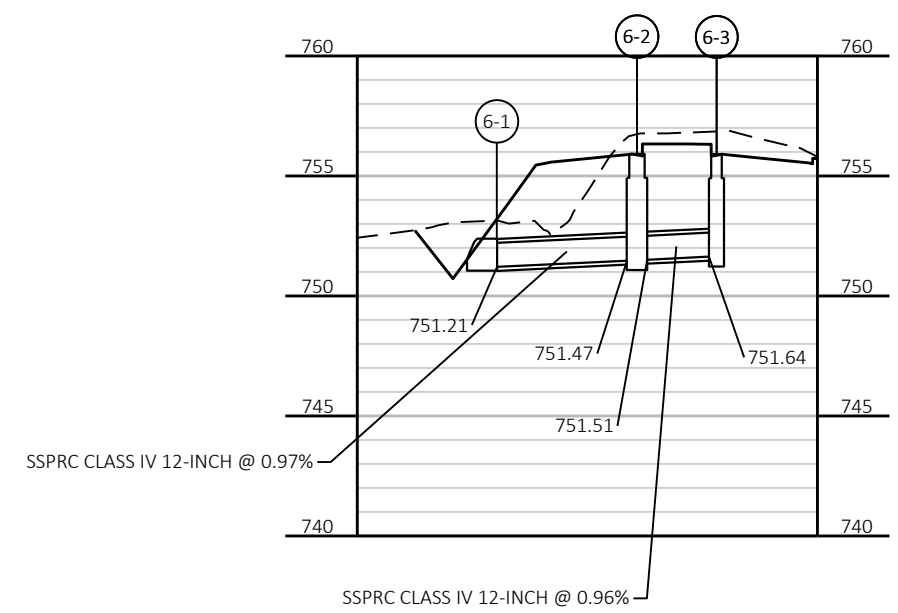
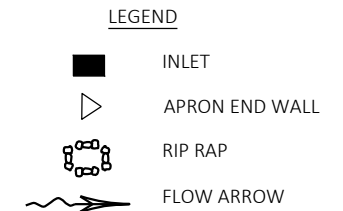
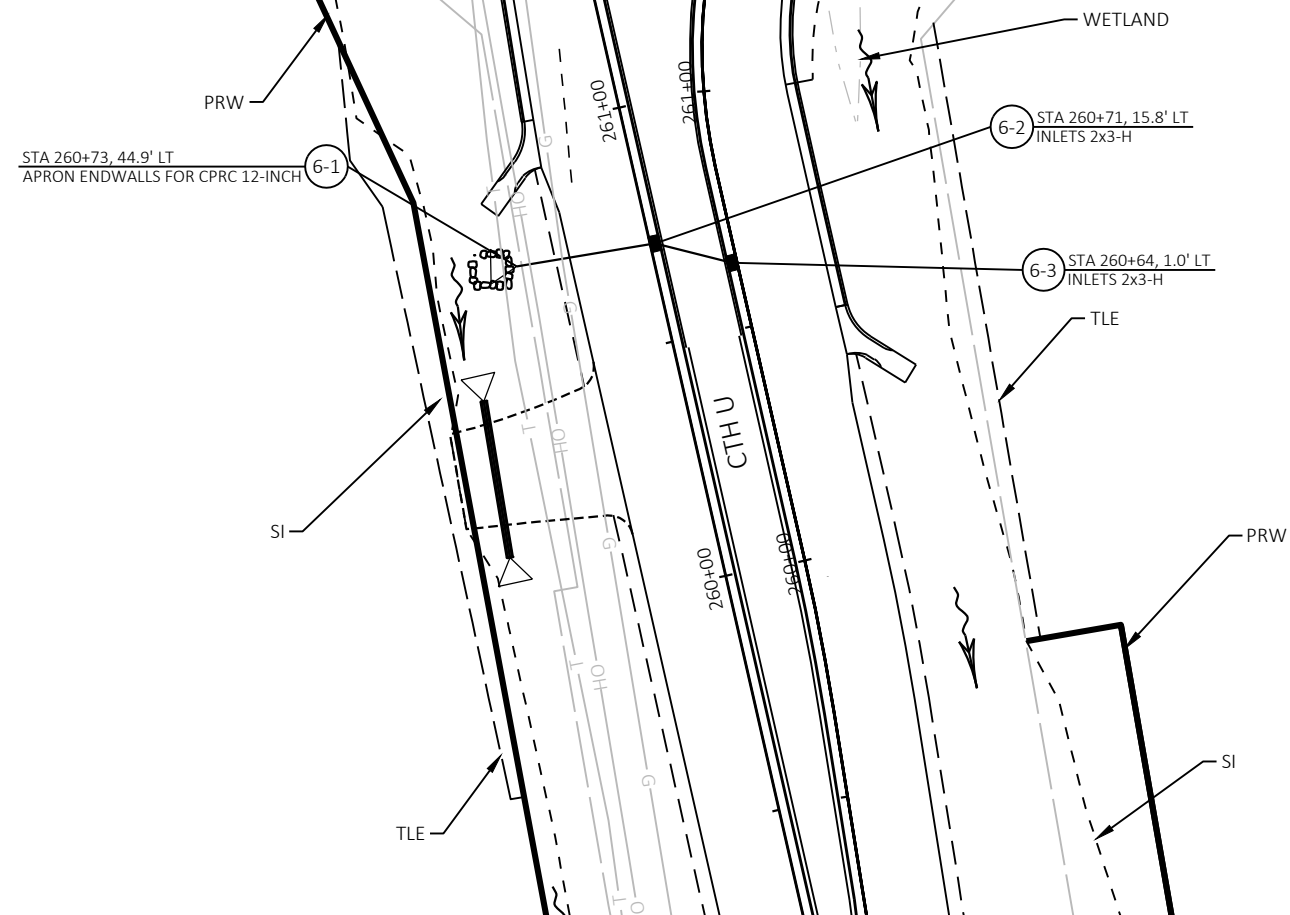





LEGEND



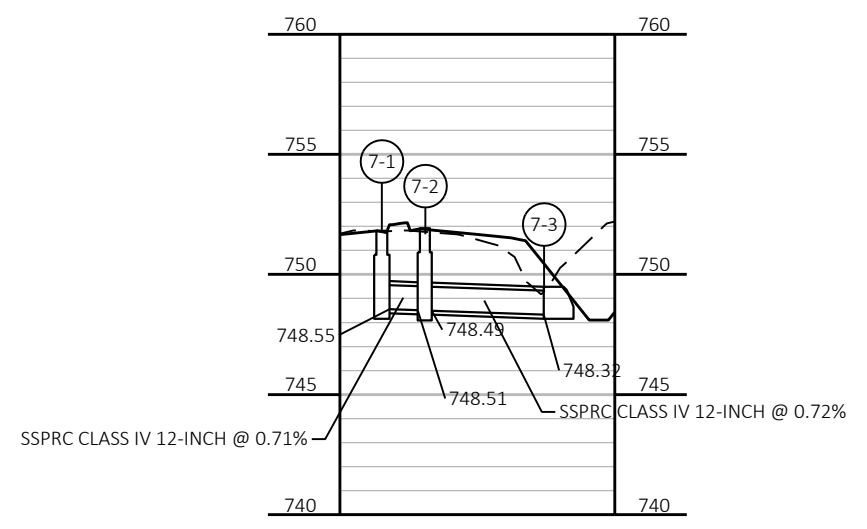
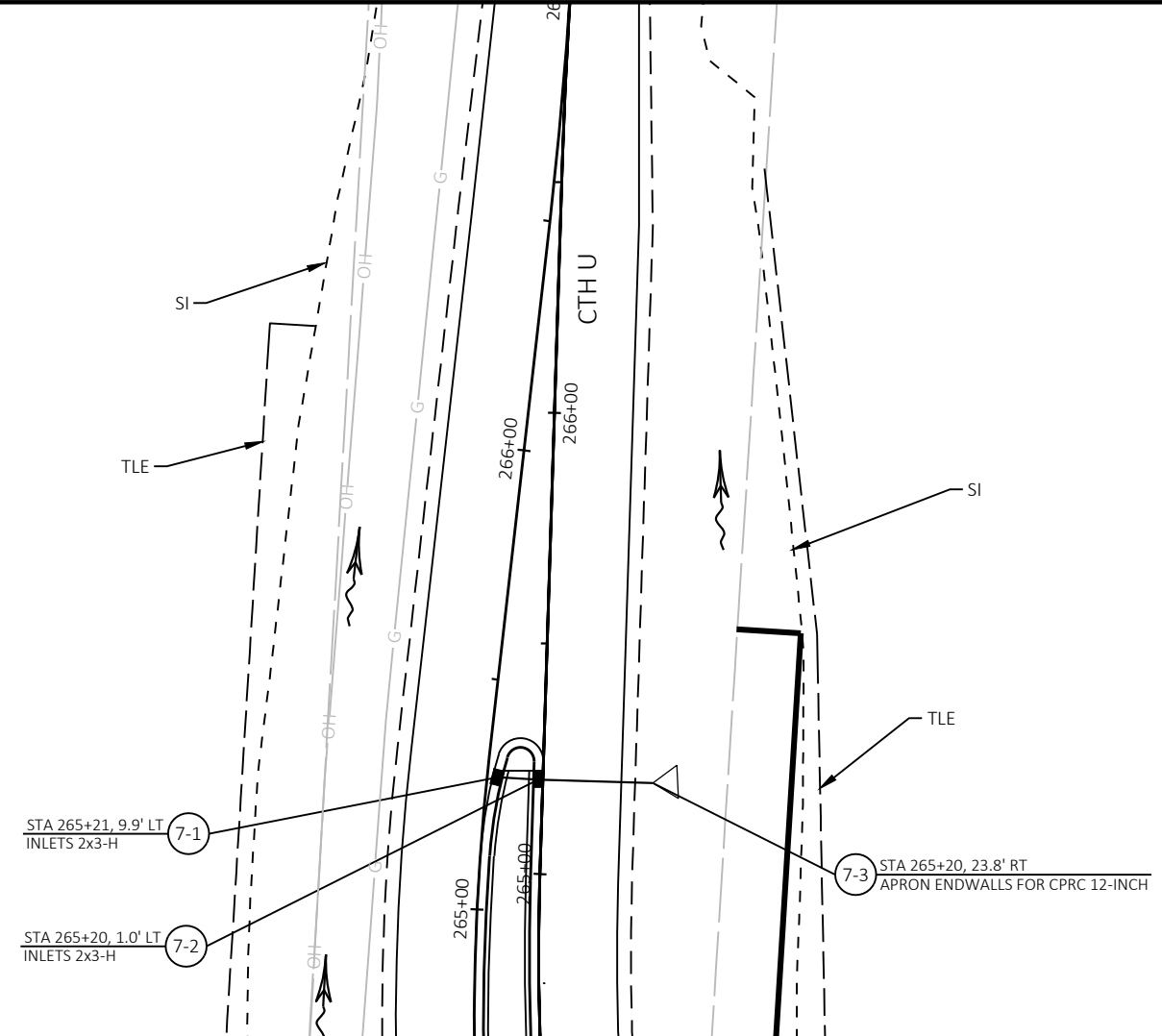

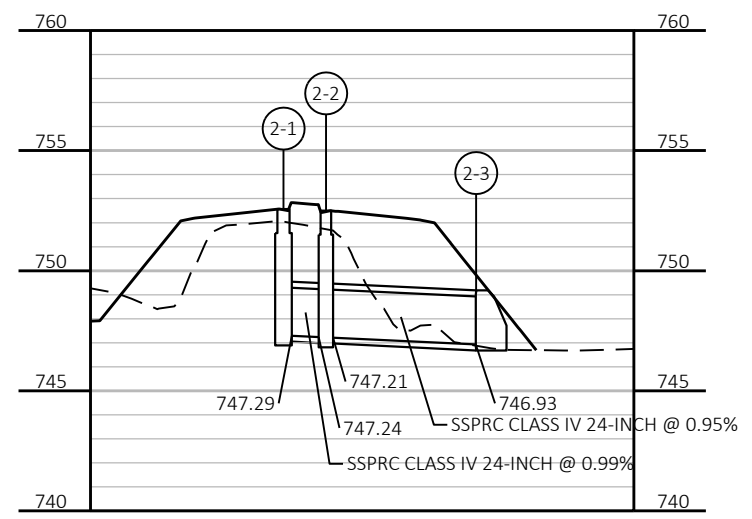
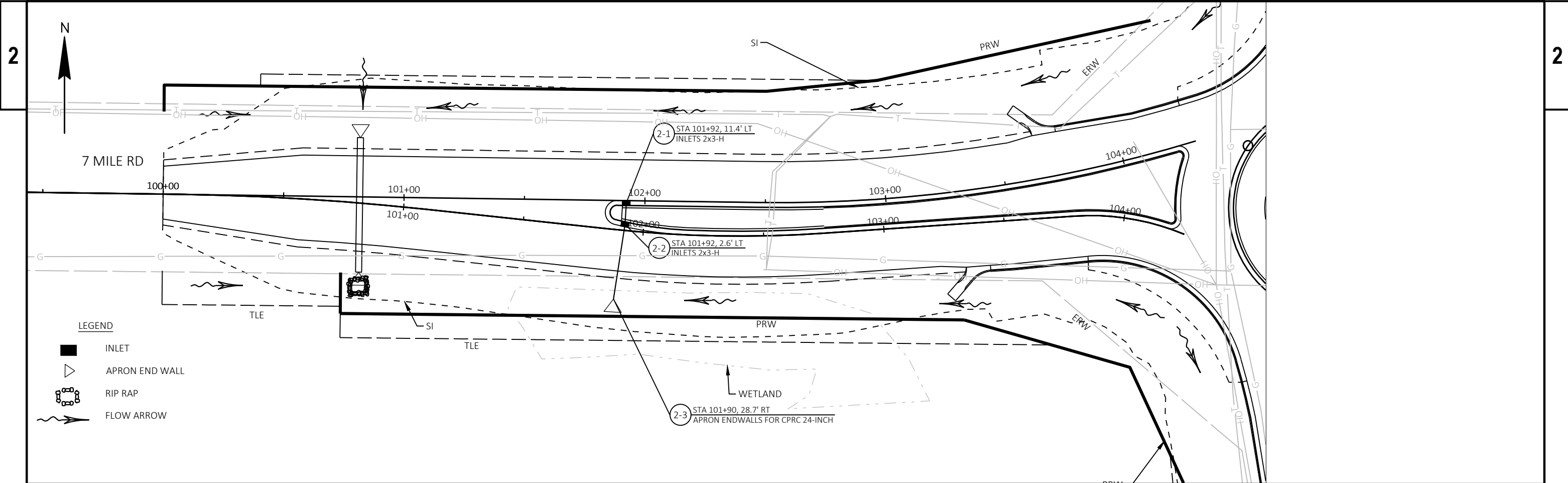
-  INLET
-  APRON END WALL
-  RIP RAP
-  FLOW ARROW

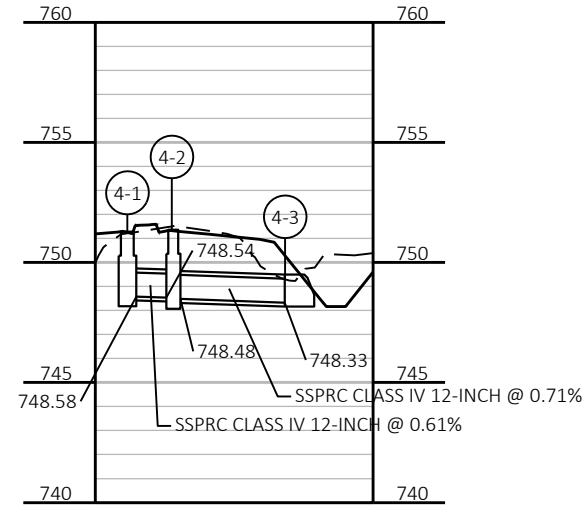
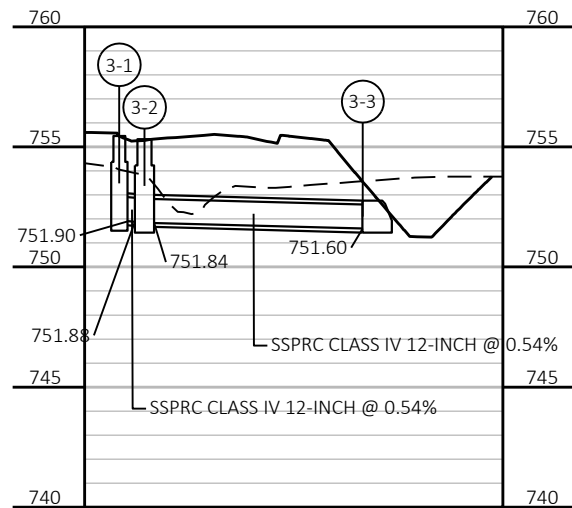
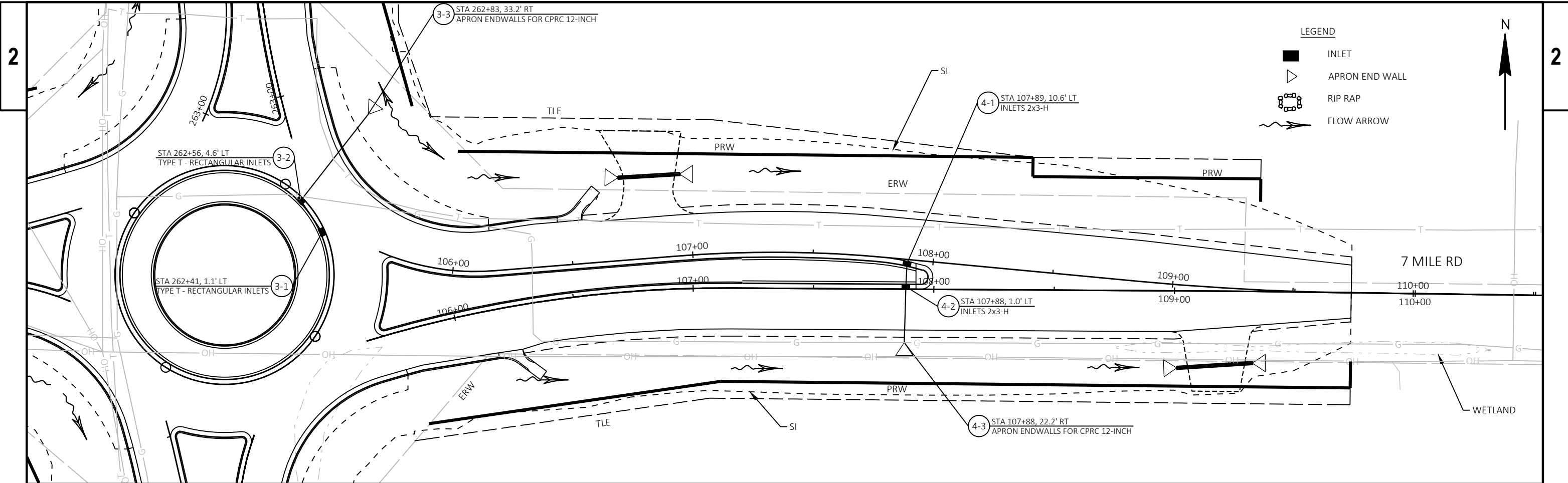





LEGEND

-  EXISTING SIGN MOUNTED ON POST(S)
-  PROPOSED SIGN MOUNTED ON POST(S)
-  DENOTES SIGN NUMBER
-  INDICATES SIGN SIZE



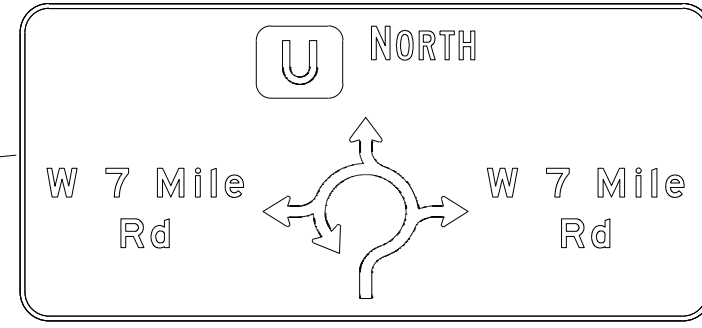
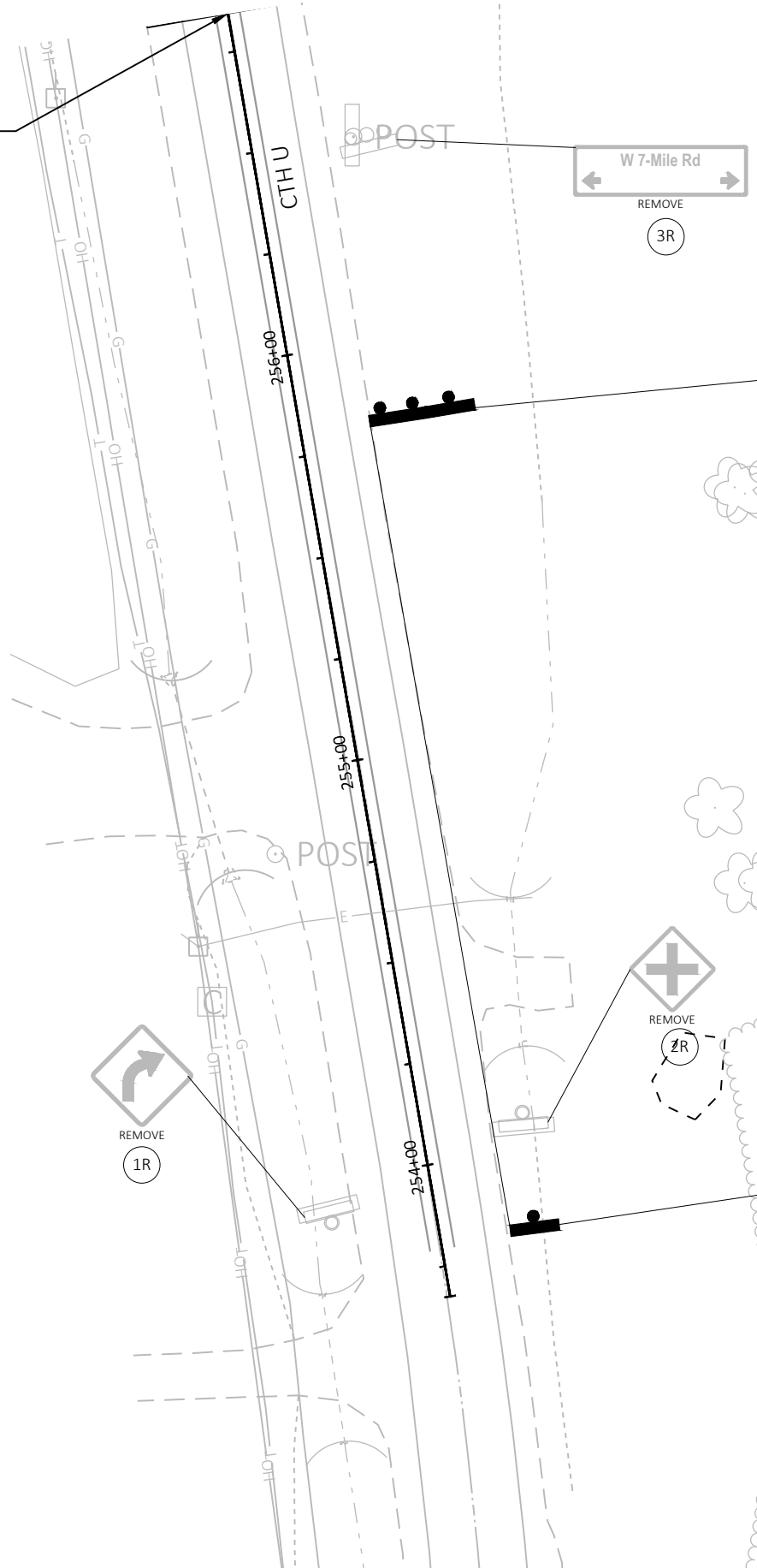

BEGIN PROJECT NB  
STA 256+84.42



263



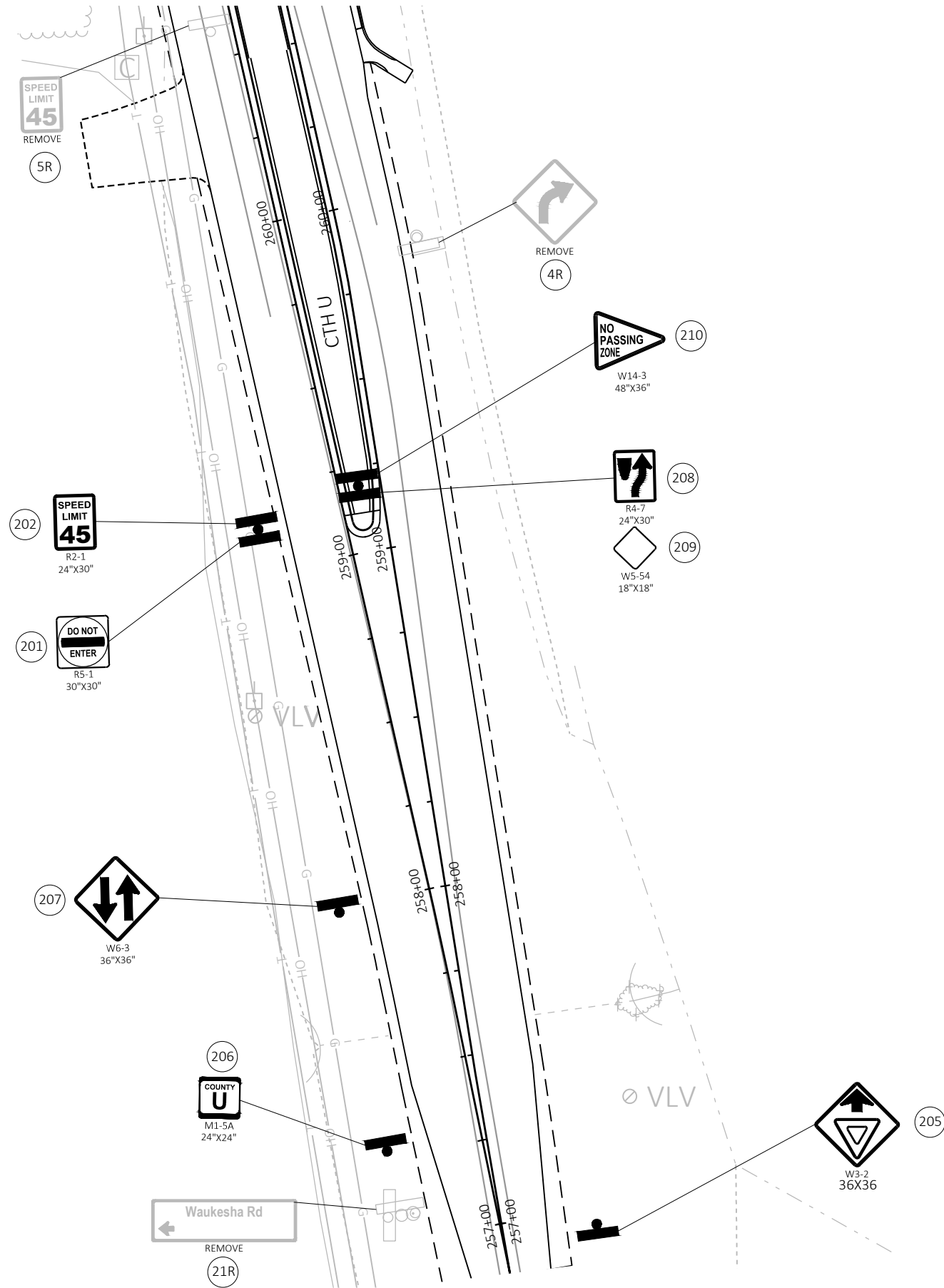

D1-62

LEGEND

-  EXISTING SIGN MOUNTED ON POST(S)
-  PROPOSED SIGN MOUNTED ON POST(S)
-  DENOTES SIGN NUMBER
-  INDICATES SIGN SIZE





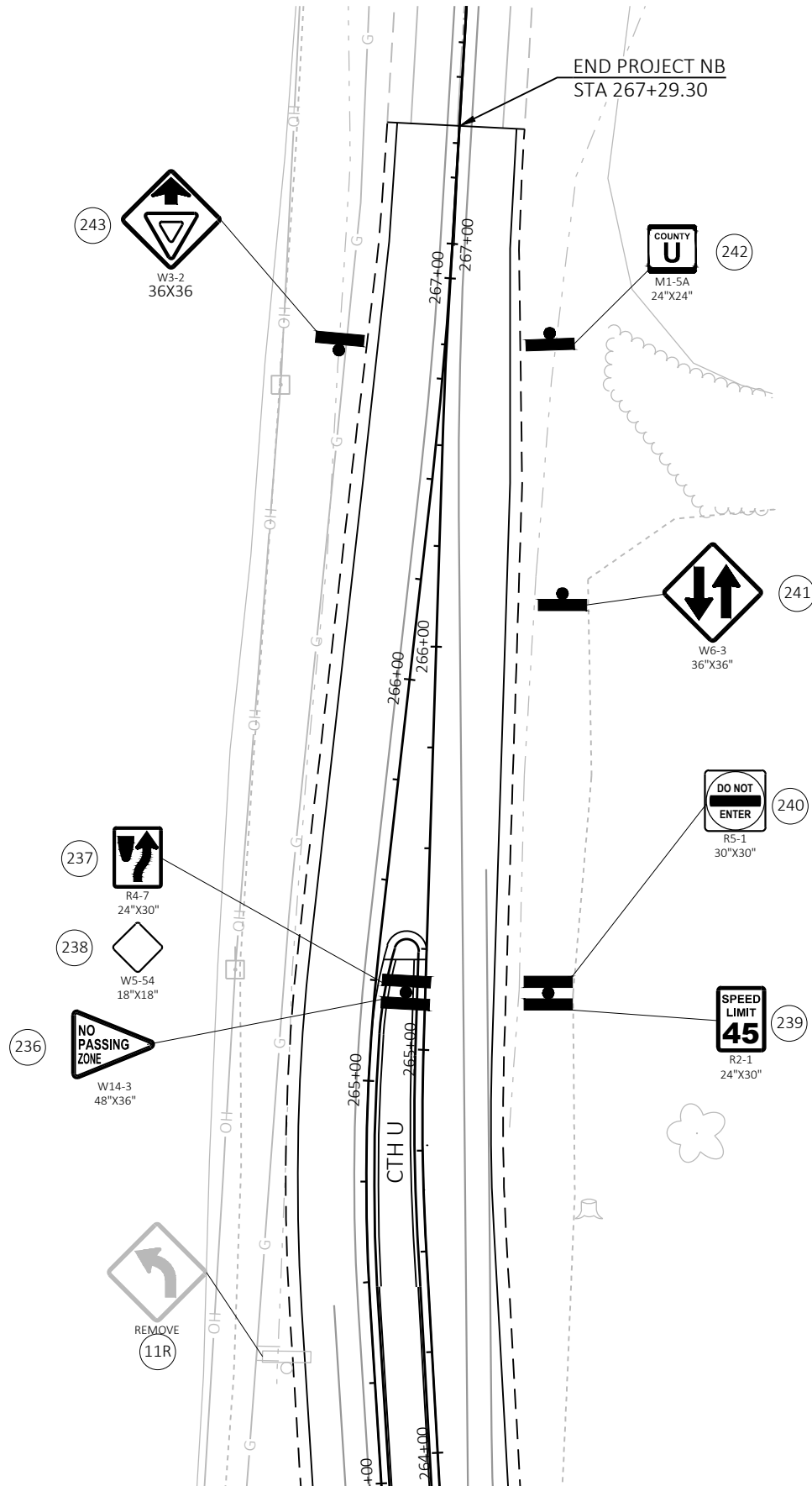

LEGEND

-  EXISTING SIGN MOUNTED ON POST(S)
-  PROPOSED SIGN MOUNTED ON POST(S)
-  DENOTES SIGN NUMBER
-  INDICATES SIGN SIZE



LEGEND

-  EXISTING SIGN MOUNTED ON POST(S)
-  PROPOSED SIGN MOUNTED ON POST(S)
-  DENOTES SIGN NUMBER
-  INDICATES SIGN SIZE

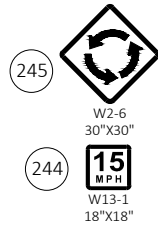
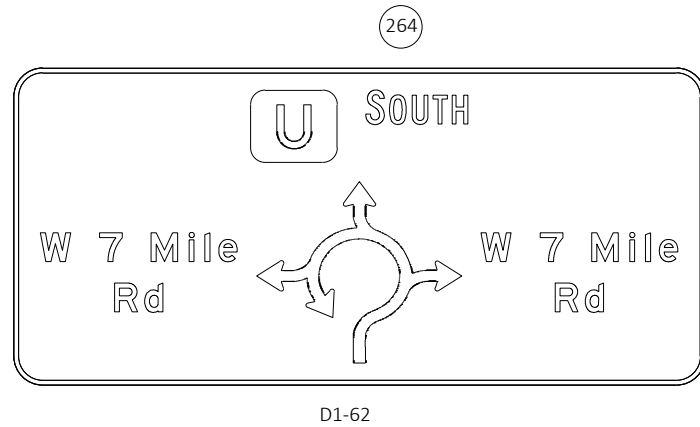

REMOVE 13R





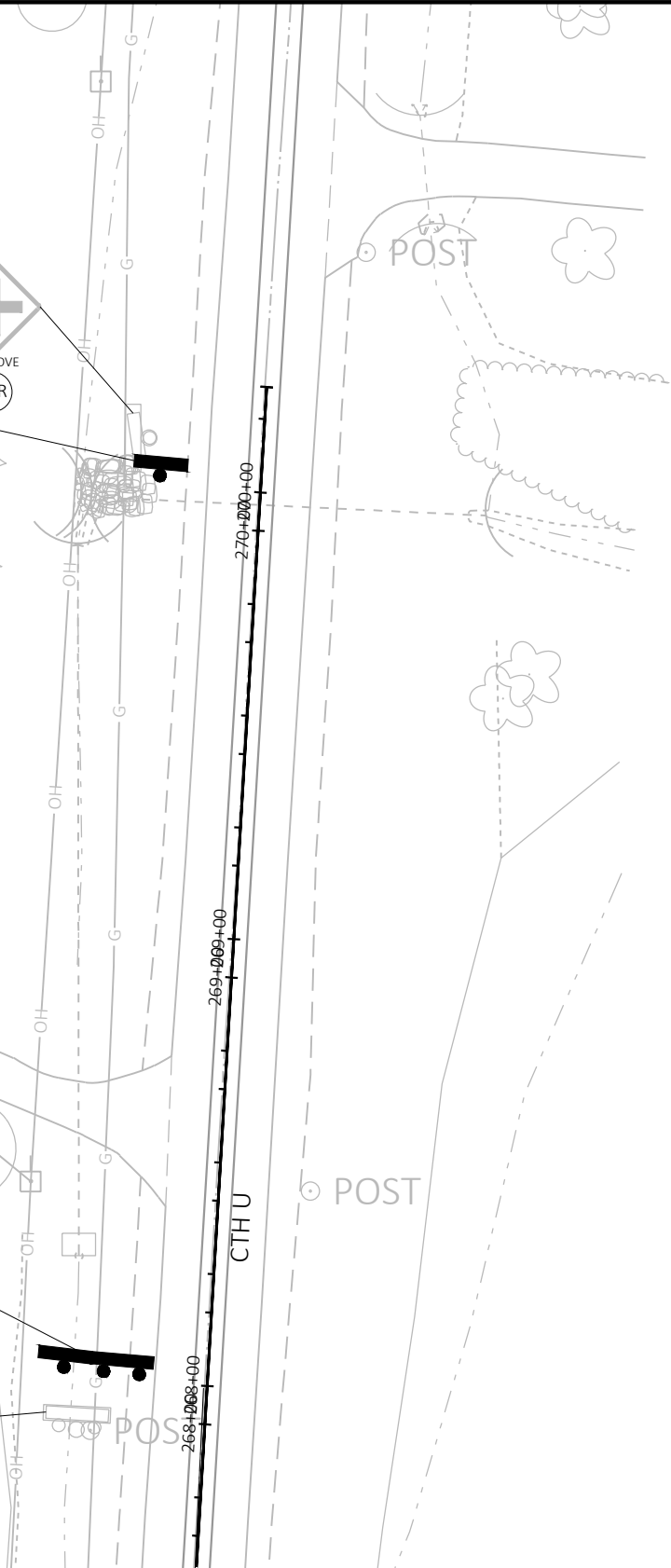

REMOVE 12R





LEGEND



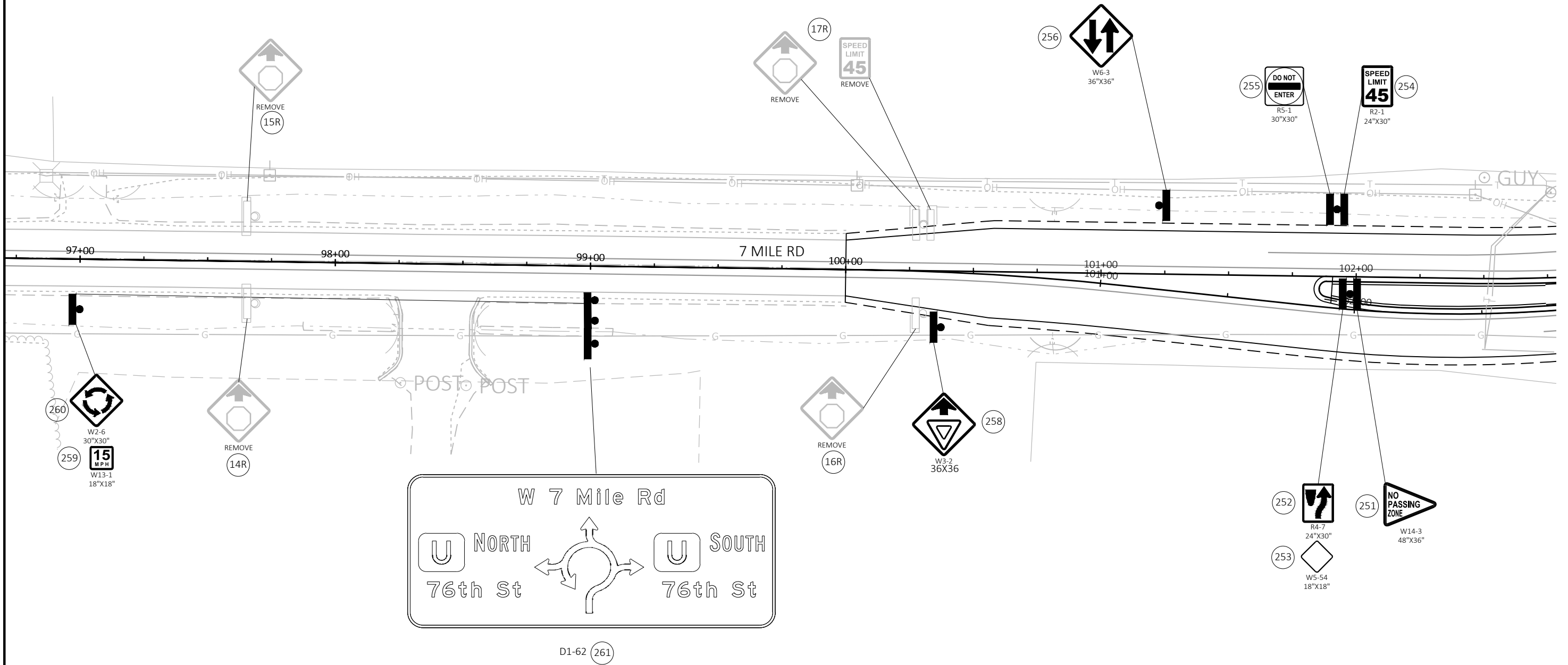

-  EXISTING SIGN MOUNTED ON POST(S)
-  PROPOSED SIGN MOUNTED ON POST(S)
-  DENOTES SIGN NUMBER
-  INDICATES SIGN SIZE



PROJECT NO: 2816-03-70	HWY: CTH U	COUNTY: RACINE	PERMANENT SIGNING	SHEET	<b>E</b>
------------------------	------------	----------------	-------------------	-------	----------





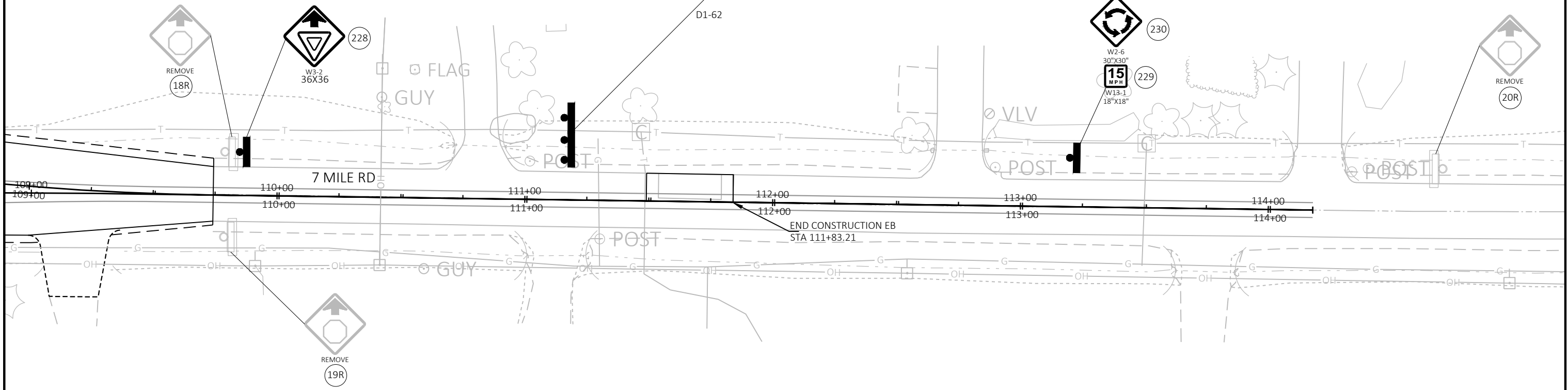
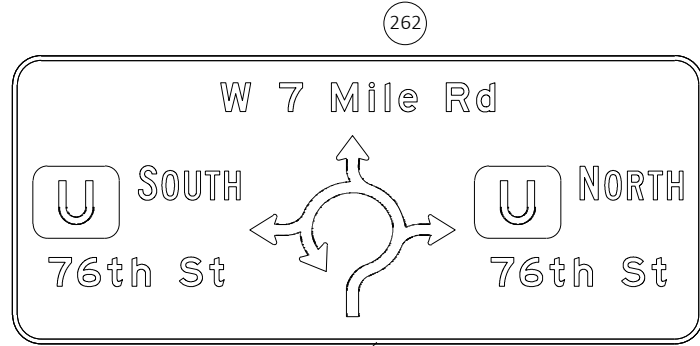

LEGEND

-  EXISTING SIGN MOUNTED ON POST(S)
-  PROPOSED SIGN MOUNTED ON POST(S)
-  DENOTES SIGN NUMBER
-  INDICATES SIGN SIZE



LEGEND

-  EXISTING SIGN MOUNTED ON POST(S)
-  PROPOSED SIGN MOUNTED ON POST(S)
-  DENOTES SIGN NUMBER
-  INDICATES SIGN SIZE

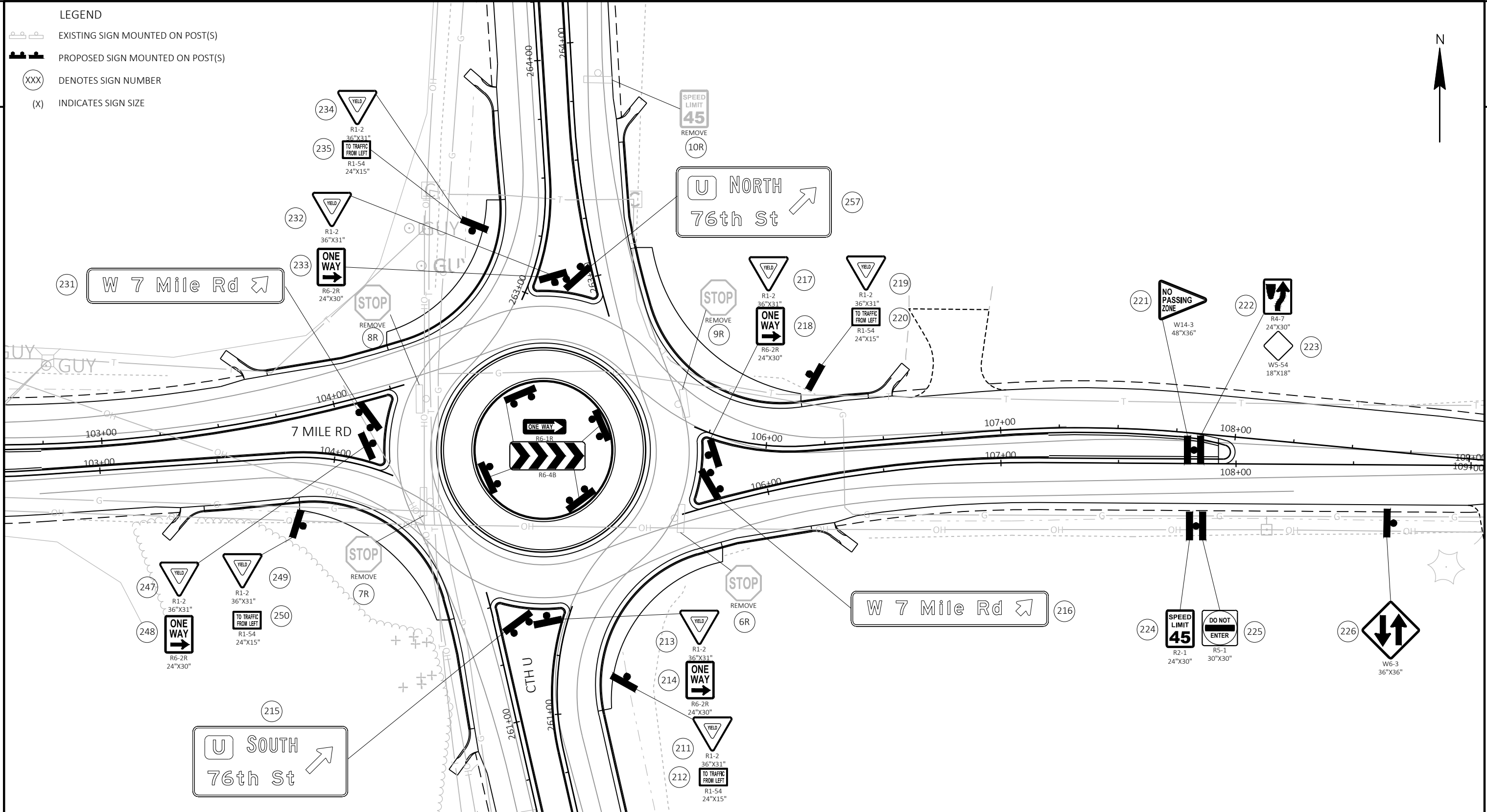

LIGHTING PLAN LEGEND

- ☒ DISTRIBUTION CENTER
- PULL BOX 24-INCH (2.5 FEET FROM FOC AND SHOULDER)
- - - CONDUIT 2-INCH UNLESS OTHERWISE NOTED
- PROPOSED LIGHTING UNIT (2.5 FEET FROM FOC AND SHOULDER)

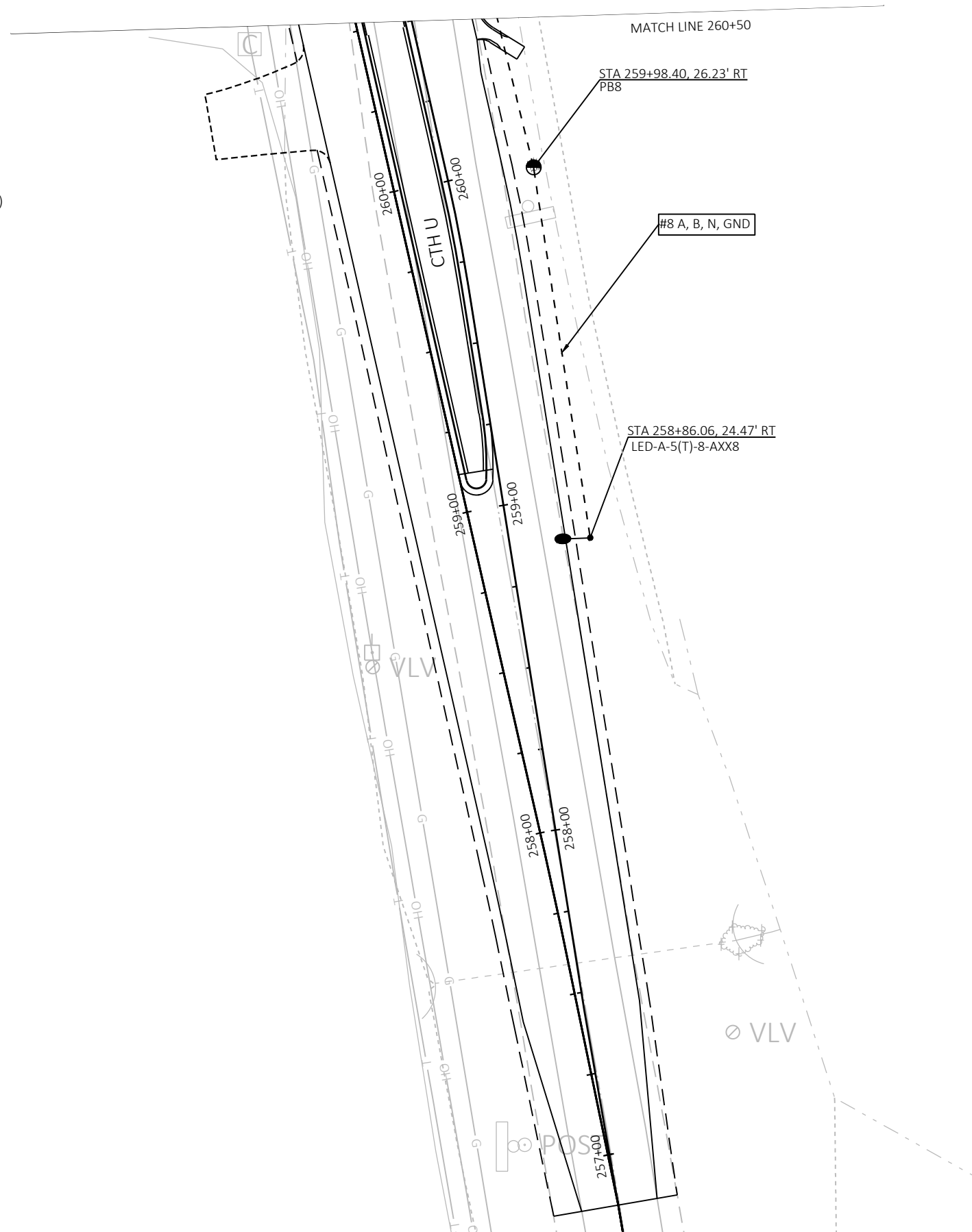
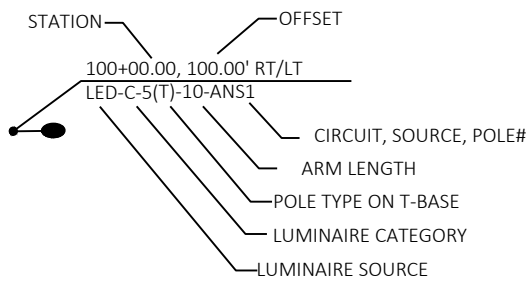

LIGHTING PLAN LEGEND

- ☒ DISTRIBUTION CENTER
- PULL BOX 24-INCH (2.5 FEET FROM FOC AND SHOULDER)
- - - CONDUIT 2-INCH UNLESS OTHERWISE NOTED
- PROPOSED LIGHTING UNIT (2.5 FEET FROM FOC AND SHOULDER)

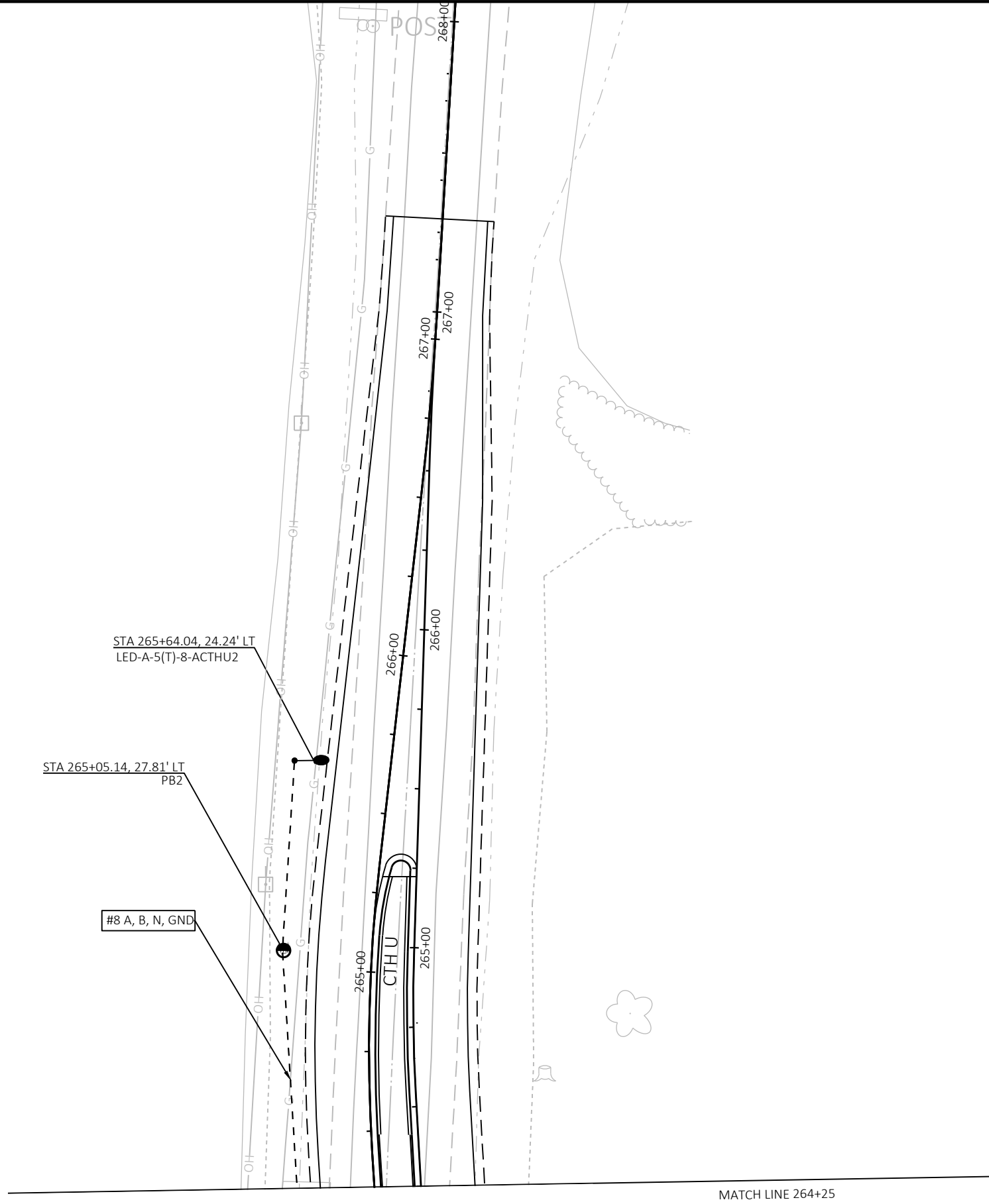
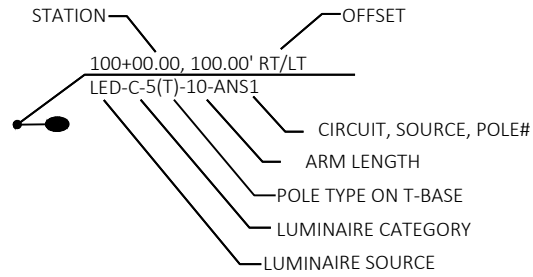

LIGHTING PLAN LEGEND

- ☒ DISTRIBUTION CENTER
- PULL BOX 24-INCH (2.5 FEET FROM FOC AND SHOULDER)
- - - CONDUIT 2-INCH UNLESS OTHERWISE NOTED
- PROPOSED LIGHTING UNIT (2.5 FEET FROM FOC AND SHOULDER)

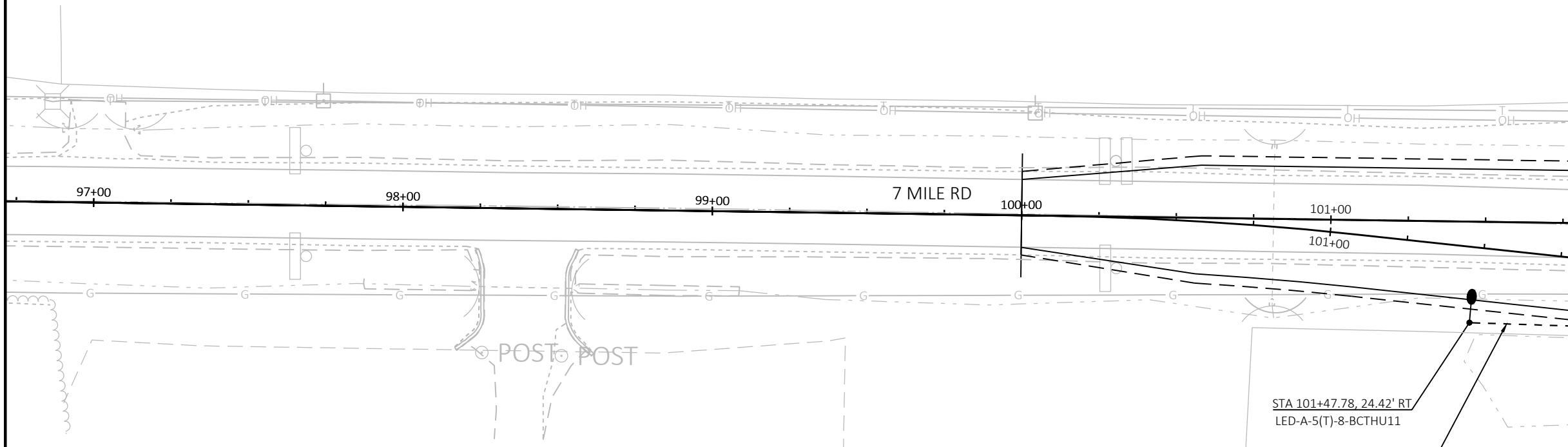
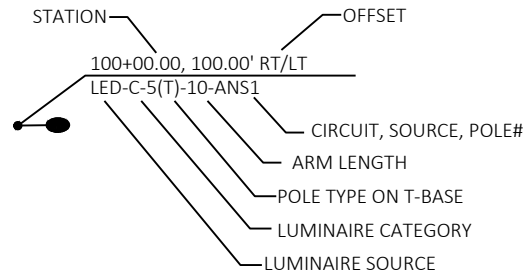

STA 101+47.78, 24.42' RT  
LED-A-5(T)-8-BCTHU11

#8 A, B, N, GND

LIGHTING PLAN LEGEND

- ☒ DISTRIBUTION CENTER
  - PULL BOX 24-INCH (2.5 FEET FROM FOC AND SHOULDER)
  - - - CONDUIT 2-INCH UNLESS OTHERWISE NOTED
  - PROPOSED LIGHTING UNIT (2.5 FEET FROM FOC AND SHOULDER)
- 
- STATION: 100+00.00, 100.00' RT/LT  
 LED-C-5(T)-10-ANS1
- OFFSET
  - CIRCUIT, SOURCE, POLE#
  - ARM LENGTH
  - POLE TYPE ON T-BASE
  - LUMINAIRE CATEGORY
  - LUMINAIRE SOURCE

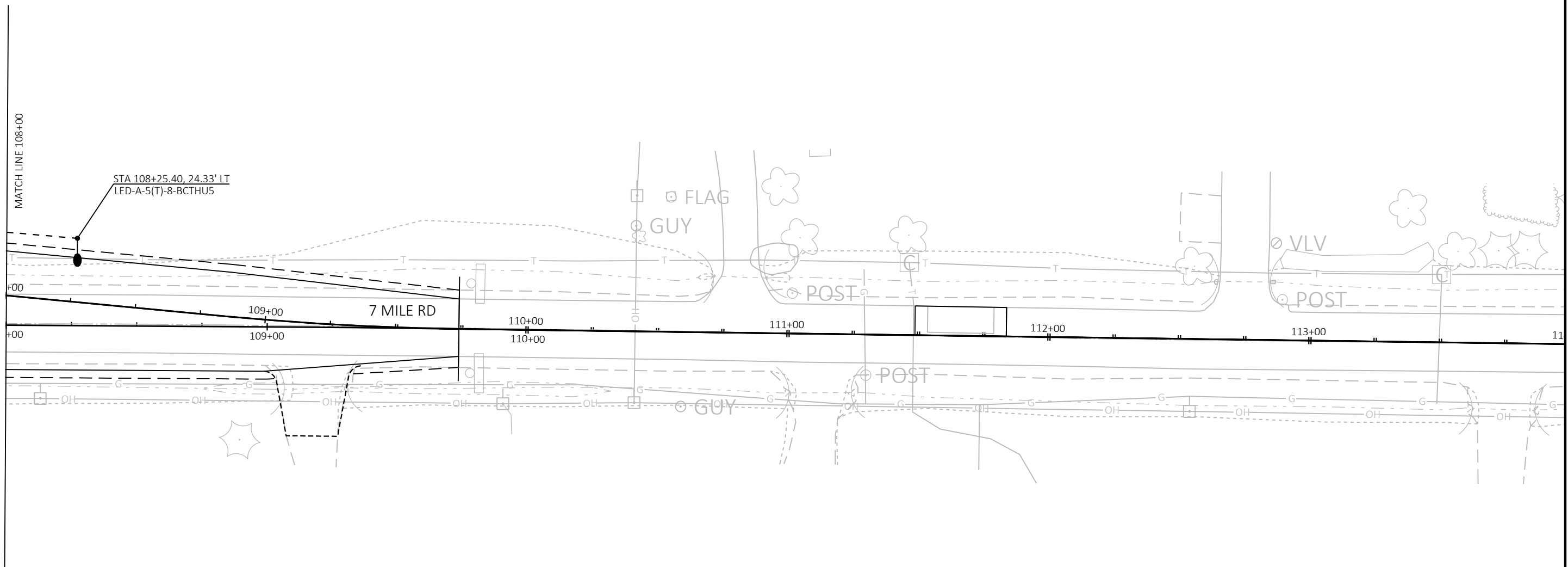

LIGHTING PLAN LEGEND

- DISTRIBUTION CENTER
- PULL BOX 24-INCH (2.5 FEET FROM FOC AND SHOULDER)
- CONDUIT 2-INCH UNLESS OTHERWISE NOTED
- PROPOSED LIGHTING UNIT (2.5 FEET FROM FOC AND SHOULDER)

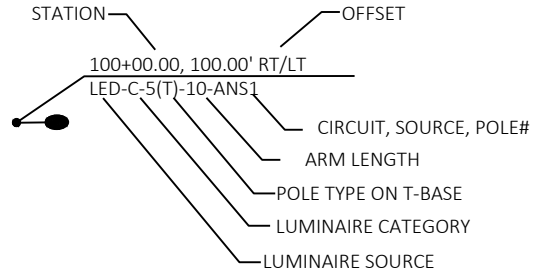

MATCH LINE 101+81

MATCH LINE 108+00

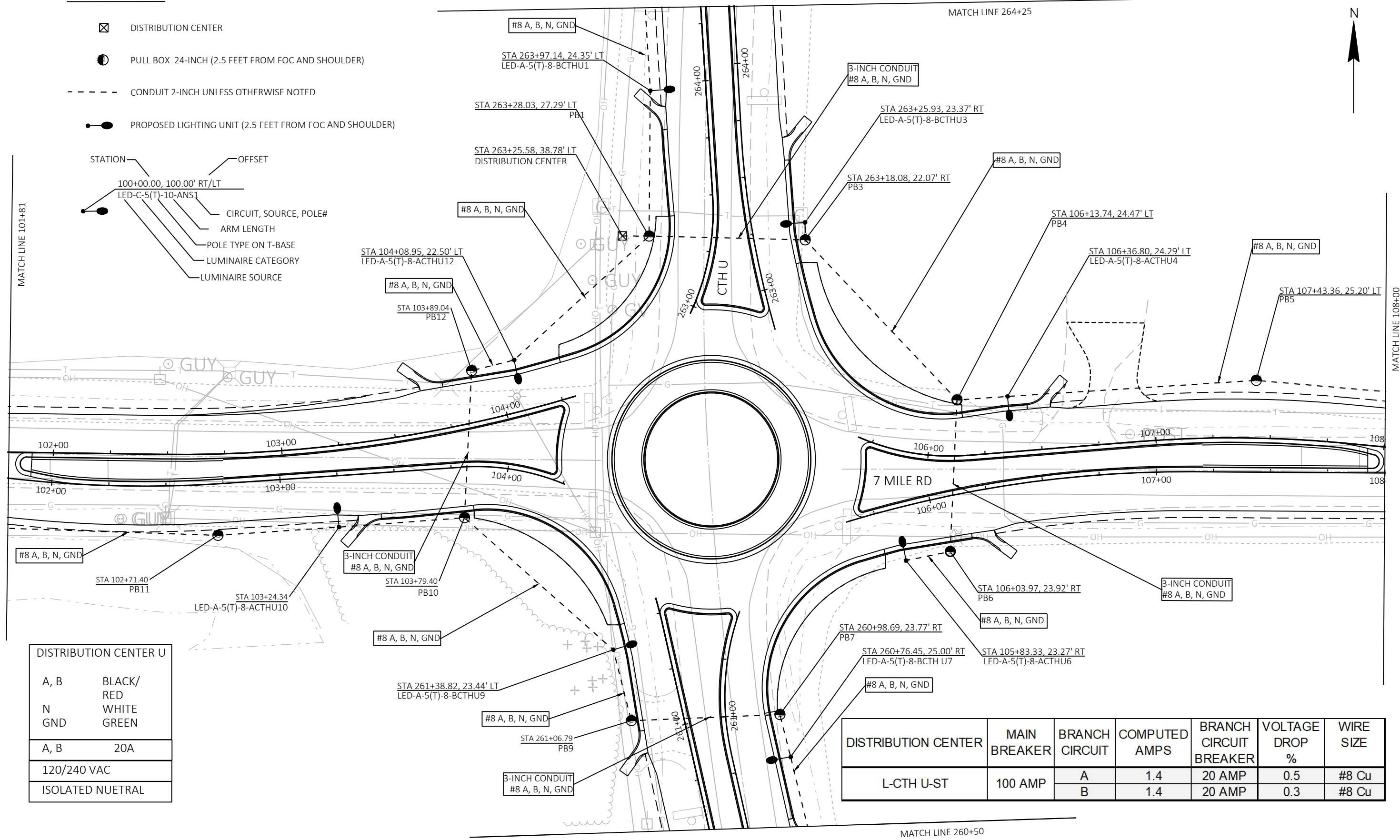

DISTRIBUTION CENTER U	
A, B	BLACK/RED
N	WHITE
GND	GREEN
A, B	20A
120/240 VAC	
ISOLATED NUETRAL	

DISTRIBUTION CENTER	MAIN BREAKER	BRANCH CIRCUIT	COMPUTED AMPS	BRANCH CIRCUIT BREAKER	VOLTAGE DROP %	WIRE SIZE
L-CTH U-ST	100 AMP	A	1.4	20 AMP	0.5	#8 Cu
		B	1.4	20 AMP	0.3	#8 Cu



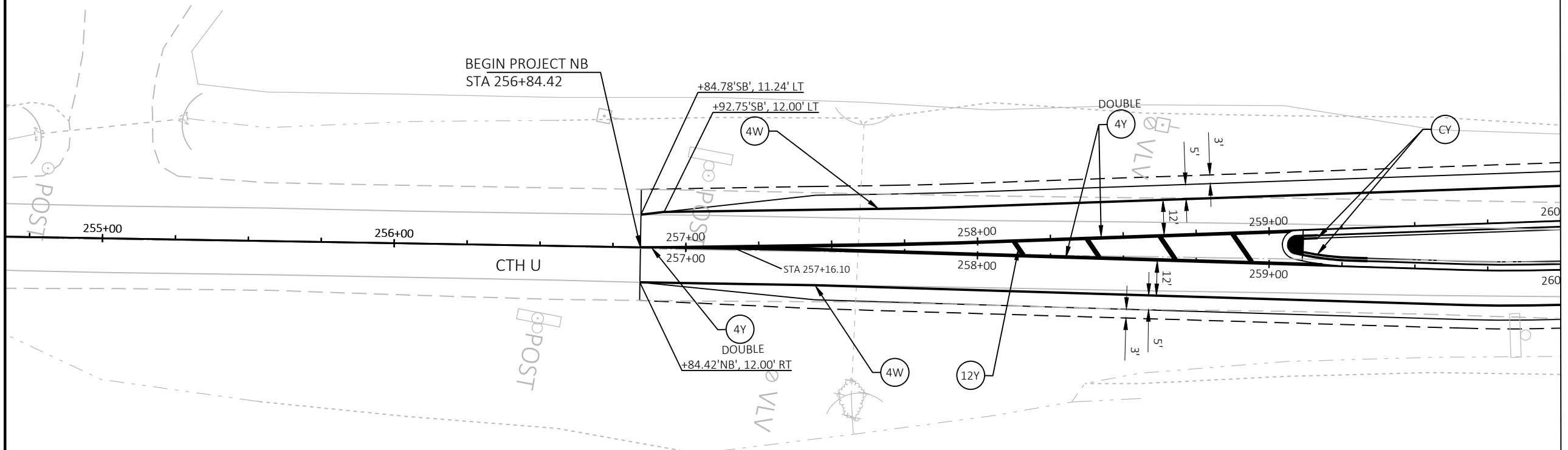

PAVEMENT MARKING LEGEND

- (4W) MARKING LINE EPOXY 4-INCH (WHITE)
- (4Y) MARKING LINE EPOXY 4-INCH (YELLOW)
- (4DW) MARKING LINE EPOXY 4-INCH (WHITE, 3' LINE, 9' SKIP)
- (8W) MARKING LINE EPOXY 8-INCH (WHITE)
- (12Y) MARKING DIAGNAL EPOXY 12-INCH (YELLOW, 25' C-C)
- (CY) MARKING CURB EPOXY (YELLOW)
- (INY) MARKING ISLAND NOSE EPOXY (YELLOW)
- (18D) MARKING LINE DOTTED EXTENSION EPOXY 18-INCH (WHITE, 2' LINE, 2' SKIP)

PROJECT NO: 2816-03-70

HWY: CTH U

COUNTY: RACINE

PAVEMENT MARKING

SHEET

E

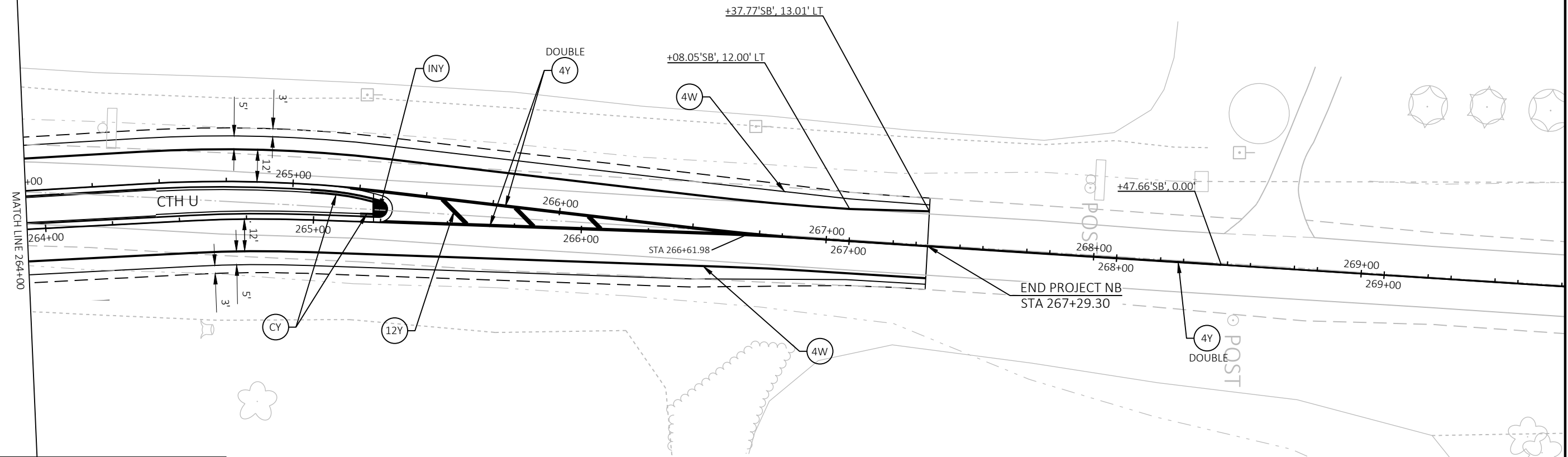

PAVEMENT MARKING LEGEND

- (4W) MARKING LINE EPOXY 4-INCH (WHITE)
- (4Y) MARKING LINE EPOXY 4-INCH (YELLOW)
- (4DW) MARKING LINE EPOXY 4-INCH (WHITE, 3' LINE, 9' SKIP)
- (8W) MARKING LINE EPOXY 8-INCH (WHITE)
- (12Y) MARKING DIAGNAL EPOXY 12-INCH (YELLOW, 25' C-C)
- (CY) MARKING CURB EPOXY (YELLOW)
- (INY) MARKING ISLAND NOSE EPOXY (YELLOW)
- (18D) MARKING LINE DOTTED EXTENSION EPOXY 18-INCH (WHITE, 2' LINE, 2' SKIP)

PROJECT NO: 2816-03-70

HWY: CTH U

COUNTY: RACINE

PAVEMENT MARKING

SHEET

E

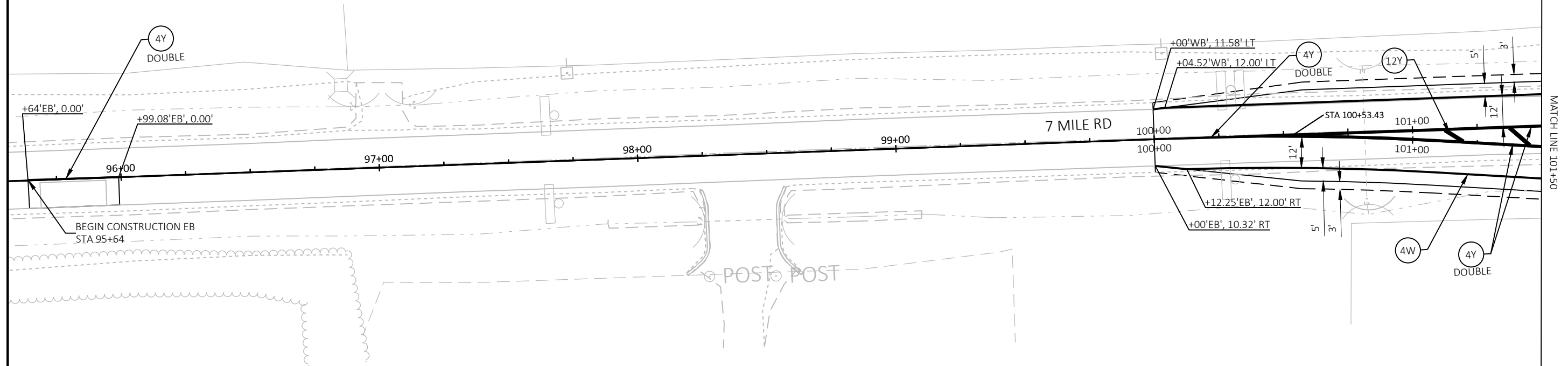

PAVEMENT MARKING LEGEND

- (4W) MARKING LINE EPOXY 4-INCH (WHITE)
- (4Y) MARKING LINE EPOXY 4-INCH (YELLOW)
- (4DW) MARKING LINE EPOXY 4-INCH (WHITE, 3' LINE, 9' SKIP)
- (8W) MARKING LINE EPOXY 8-INCH (WHITE)
- (12Y) MARKING DIAGNAL EPOXY 12-INCH (YELLOW, 25' C-C)
- (CY) MARKING CURB EPOXY (YELLOW)
- (INY) MARKING ISLAND NOSE EPOXY (YELLOW)
- (18D) MARKING LINE DOTTED EXTENSION EPOXY 18-INCH (WHITE, 2' LINE, 2' SKIP)

PROJECT NO: 2816-03-70

HWY: CTH U

COUNTY: RACINE

PAVEMENT MARKING

SHEET

E

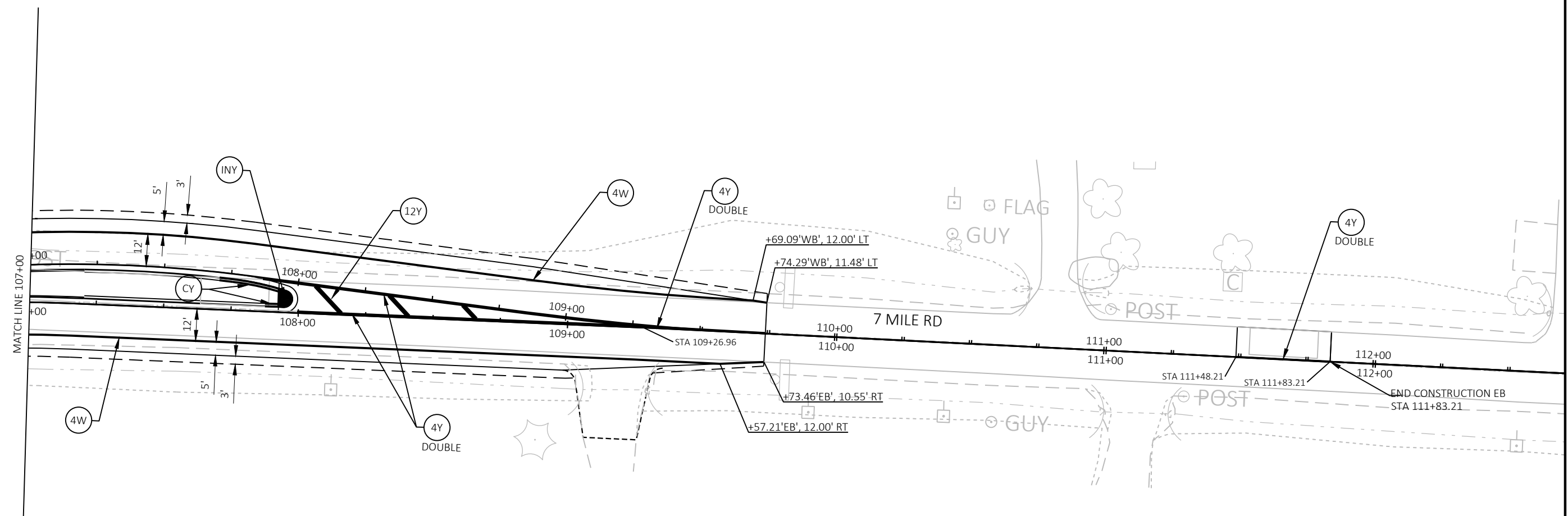

PAVEMENT MARKING LEGEND

- (4W) MARKING LINE EPOXY 4-INCH (WHITE)
- (4Y) MARKING LINE EPOXY 4-INCH ( YELLOW)
- (4DW) MARKING LINE EPOXY 4-INCH (WHITE, 3' LINE, 9' SKIP)
- (8W) MARKING LINE EPOXY 8-INCH (WHITE)
- (12Y) MARKING DIAGNAL EPOXY 12-INCH (YELLOW, 25' C-C)
- (CY) MARKING CURB EPOXY (YELLOW)
- (INY) MARKING ISLAND NOSE EPOXY (YELLOW)
- (18D) MARKING LINE DOTTED EXTENSION EPOXY 18-INCH (WHITE, 2' LINE, 2' SKIP)

PROJECT NO: 2816-03-70	HWY: CTH U	COUNTY: RACINE	PAVEMENT MARKING
			SHEET <b>E</b>

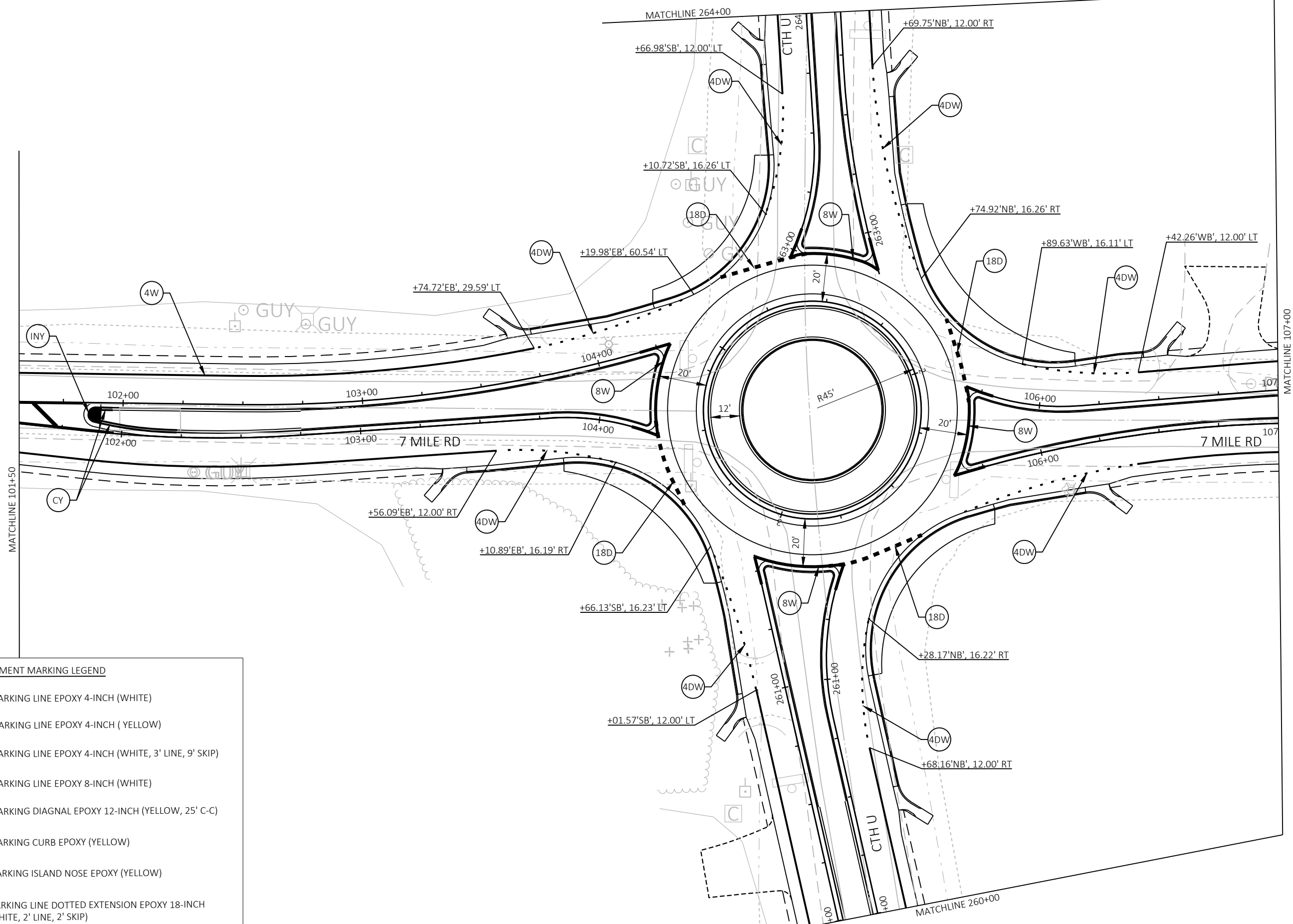

**PAVEMENT MARKING LEGEND**

- (4W) MARKING LINE EPOXY 4-INCH (WHITE)
- (4Y) MARKING LINE EPOXY 4-INCH (YELLOW)
- (4DW) MARKING LINE EPOXY 4-INCH (WHITE, 3' LINE, 9' SKIP)
- (8W) MARKING LINE EPOXY 8-INCH (WHITE)
- (12Y) MARKING DIAGNAL EPOXY 12-INCH (YELLOW, 25' C-C)
- (CY) MARKING CURB EPOXY (YELLOW)
- (INY) MARKING ISLAND NOSE EPOXY (YELLOW)
- (18D) MARKING LINE DOTTED EXTENSION EPOXY 18-INCH (WHITE, 2' LINE, 2' SKIP)

PROJECT NO: 2816-03-70

HWY: CTH U



COUNTY: RACINE

PAVEMENT MARKING

SHEET

E

LEGEND

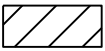
-  BARRICADE TYPE III
-  BARRICADE TYPE III WITH ATTACHED SIGN
-  SIGN ON TEMPORARY SUPPORT
-  WORK AREA

PLACE JUST SOUTH OF 8 MILE ROAD

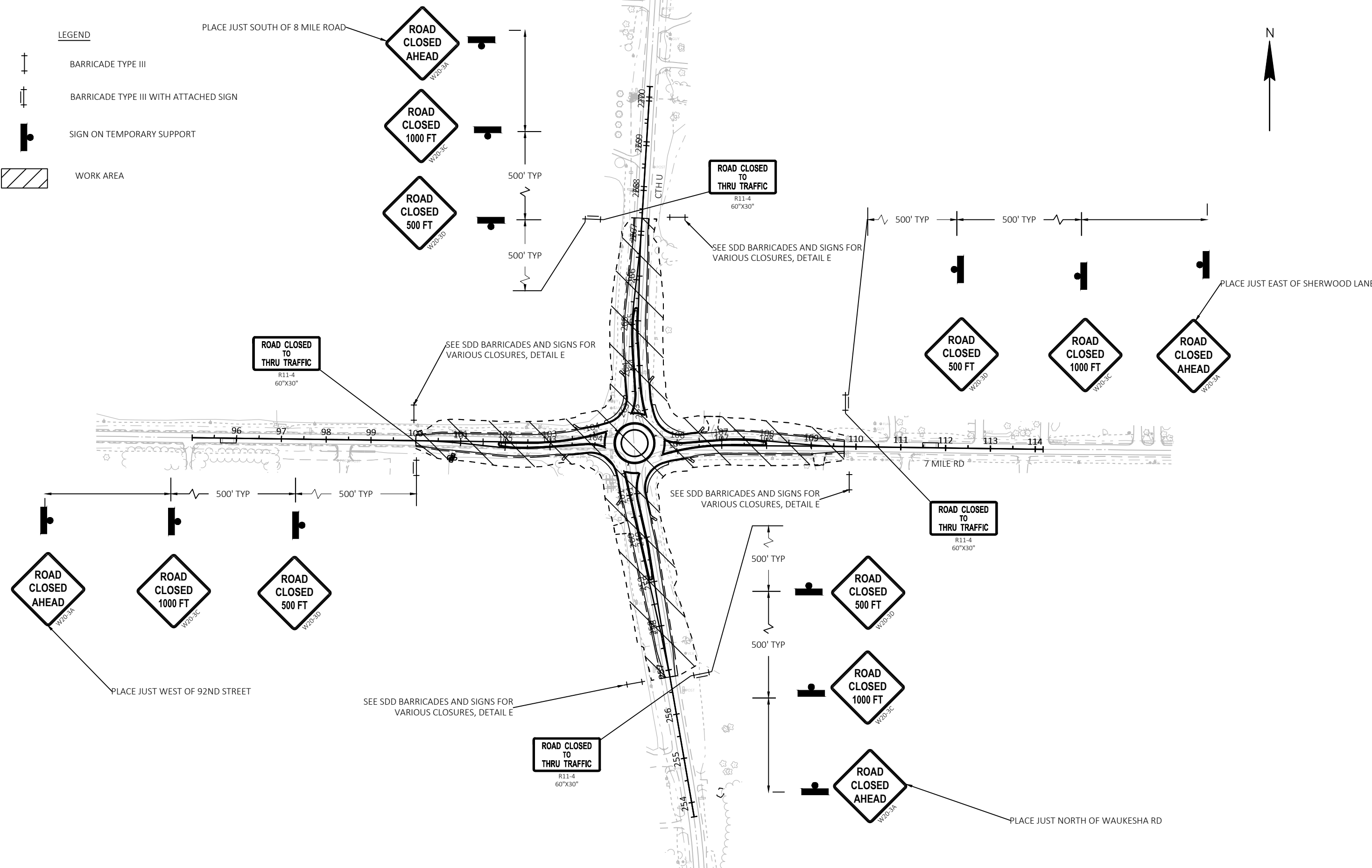

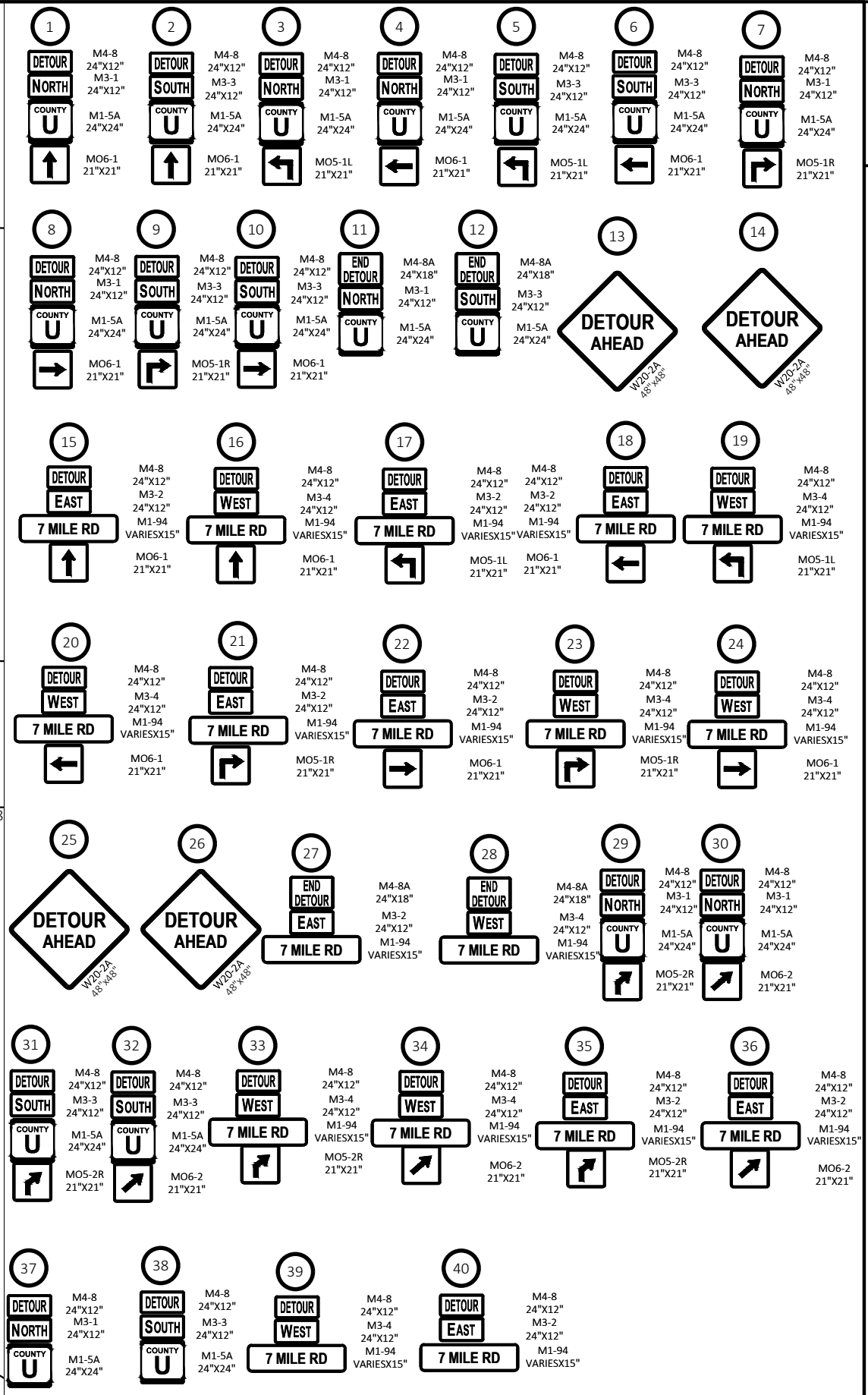
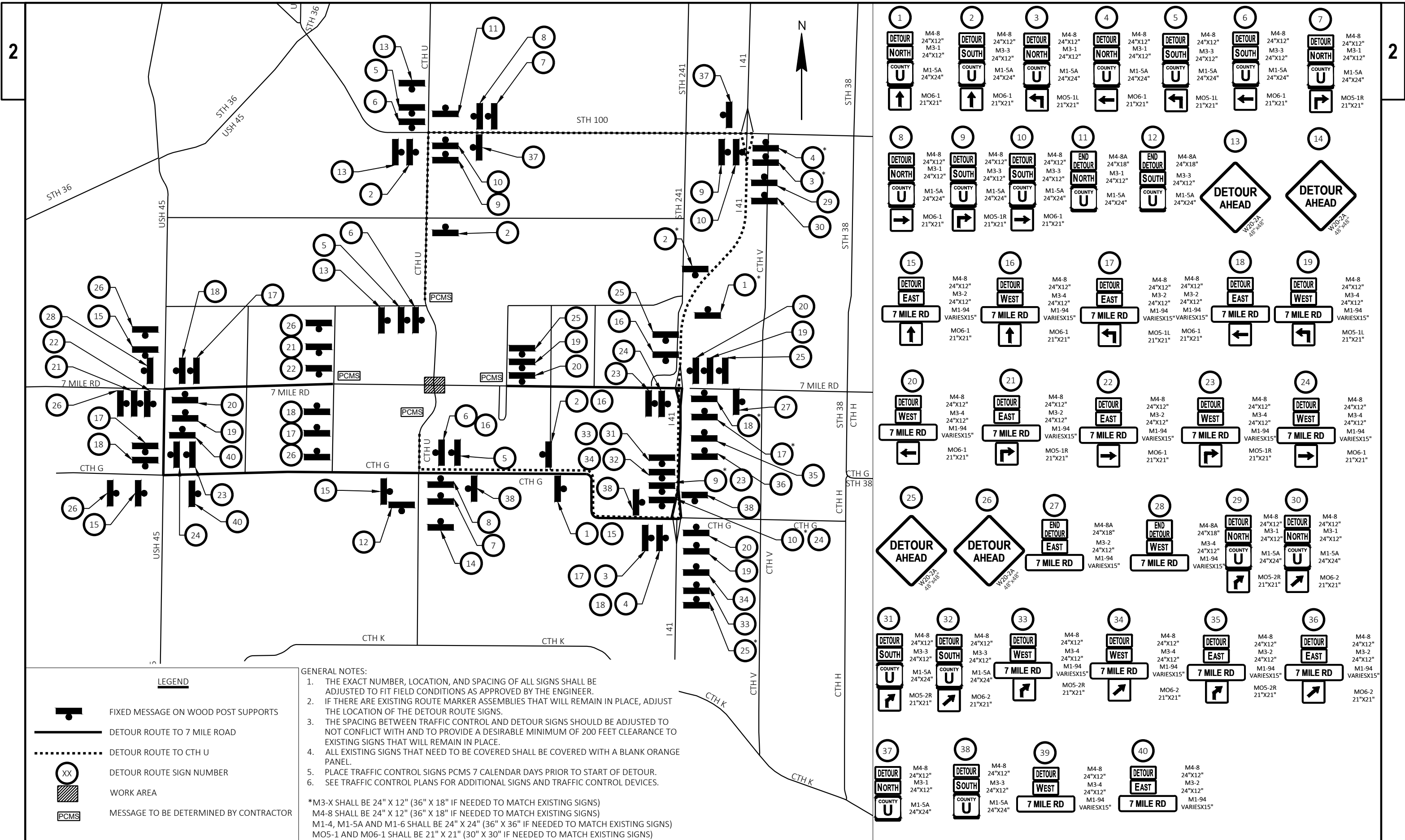

CURVE 'SB'1  
 PI STA = 257+82.47  
 Y = 223148.66  
 X = 579365.02  
 PC STA = 257+71.22  
 Y = 223137.64  
 X = 579367.29  
 PT STA = 257+93.73  
 Y = 223159.64  
 X = 579362.52  
 DELTA = 1°10'23"  
 D = 5°12'31"  
 T = 11.26'  
 L = 22.52'  
 R = 1100.00'

CURVE 'SB'2  
 PI STA = 261+72.09  
 Y = 223528.54  
 X = 579278.48  
 PC STA = 261+45.09  
 Y = 223502.22  
 X = 579284.47  
 PT STA = 261+98.76  
 Y = 223552.34  
 X = 579265.71  
 DELTA = 15°22'39"  
 D = 28°38'52"  
 T = 27.00'  
 L = 53.68'  
 R = 200.00'

CURVE 'SB'3  
 PI STA = 263+06.90  
 Y = 223640.68  
 X = 579309.57  
 PC STA = 262+58.13  
 Y = 223606.94  
 X = 579274.36  
 PT STA = 263+49.44  
 Y = 223689.35  
 X = 579306.50  
 DELTA = 49°49'24"  
 D = 54°34'03"  
 T = 48.77'  
 L = 91.31'  
 R = 105.00'

CURVE 'SB'4  
 PI STA = 264+88.46  
 Y = 223828.09  
 X = 579297.75  
 PC STA = 264+43.55  
 Y = 223783.28  
 X = 579300.58  
 PT STA = 265+33.13  
 Y = 223872.71  
 X = 579302.80  
 DELTA = 10°03'50"  
 D = 11°14'04"  
 T = 44.91'  
 L = 89.58'  
 R = 510.00'

CURVE 'SB'5  
 PI STA = 266+78.88  
 Y = 224017.53  
 X = 579319.19  
 PC STA = 266+49.69  
 Y = 223988.53  
 X = 579315.90  
 PT STA = 267+08.05  
 Y = 224046.67  
 X = 579320.92  
 DELTA = 3°02'23"  
 D = 5°12'31"  
 T = 29.19'  
 L = 58.36'  
 R = 1100.00'

CURVE 'NB'2  
 PI STA = 259+84.19  
 Y = 223348.50  
 X = 579336.66  
 PC STA = 259+67.72  
 Y = 223332.23  
 X = 579339.26  
 PT STA = 260+00.66  
 Y = 223364.57  
 X = 579333.01  
 DELTA = 3°42'03"  
 D = 11°14'04"  
 T = 16.48'  
 L = 32.94'  
 R = 510.00'

CURVE 'NB'3  
 PI STA = 261+41.04  
 Y = 223501.46  
 X = 579301.91  
 PC STA = 260+84.28  
 Y = 223446.11  
 X = 579314.48  
 PT STA = 261+89.08  
 Y = 223543.78  
 X = 579339.73  
 DELTA = 54°35'16"  
 D = 52°05'13"  
 T = 56.76'  
 L = 104.80'  
 R = 110.00'

CURVE 'NB'4  
 PI STA = 263+05.65  
 Y = 223651.96  
 X = 579322.57  
 PC STA = 262+40.29  
 Y = 223591.66  
 X = 579347.79  
 PT STA = 263+69.75  
 Y = 223717.22  
 X = 579318.94  
 DELTA = 19°31'11"  
 D = 15°04'40"  
 T = 65.36'  
 L = 129.46'  
 R = 380.00'

CURVE 'NB'5  
 PI STA = 266+70.29  
 Y = 224017.53  
 X = 579319.19  
 PC STA = 266+54.93  
 Y = 224002.19  
 X = 579318.70  
 PT STA = 266+85.64  
 Y = 224032.86  
 X = 579320.10  
 DELTA = 1°35'58"  
 D = 5°12'31"  
 T = 15.35'  
 L = 30.71'  
 R = 1100.00'

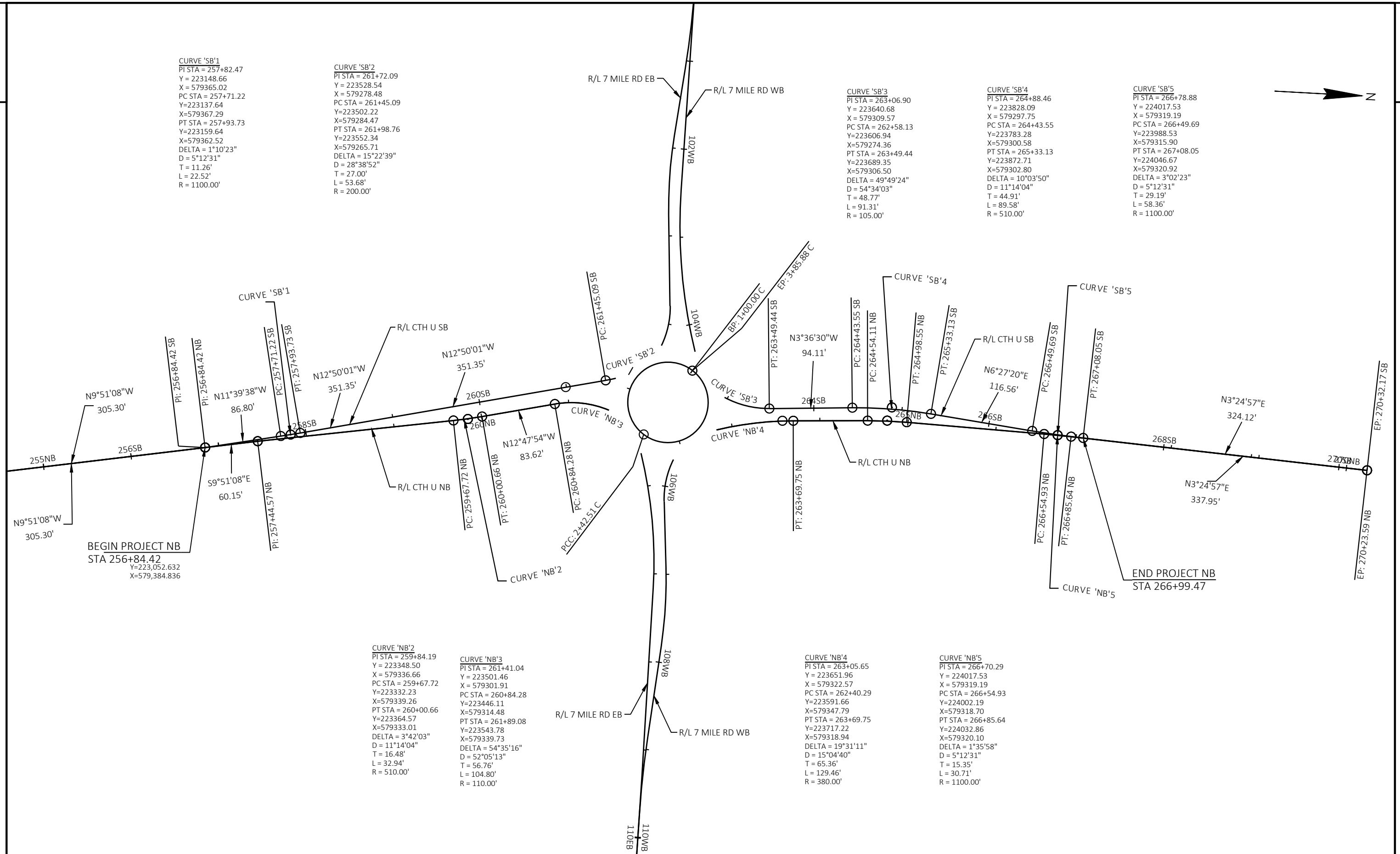



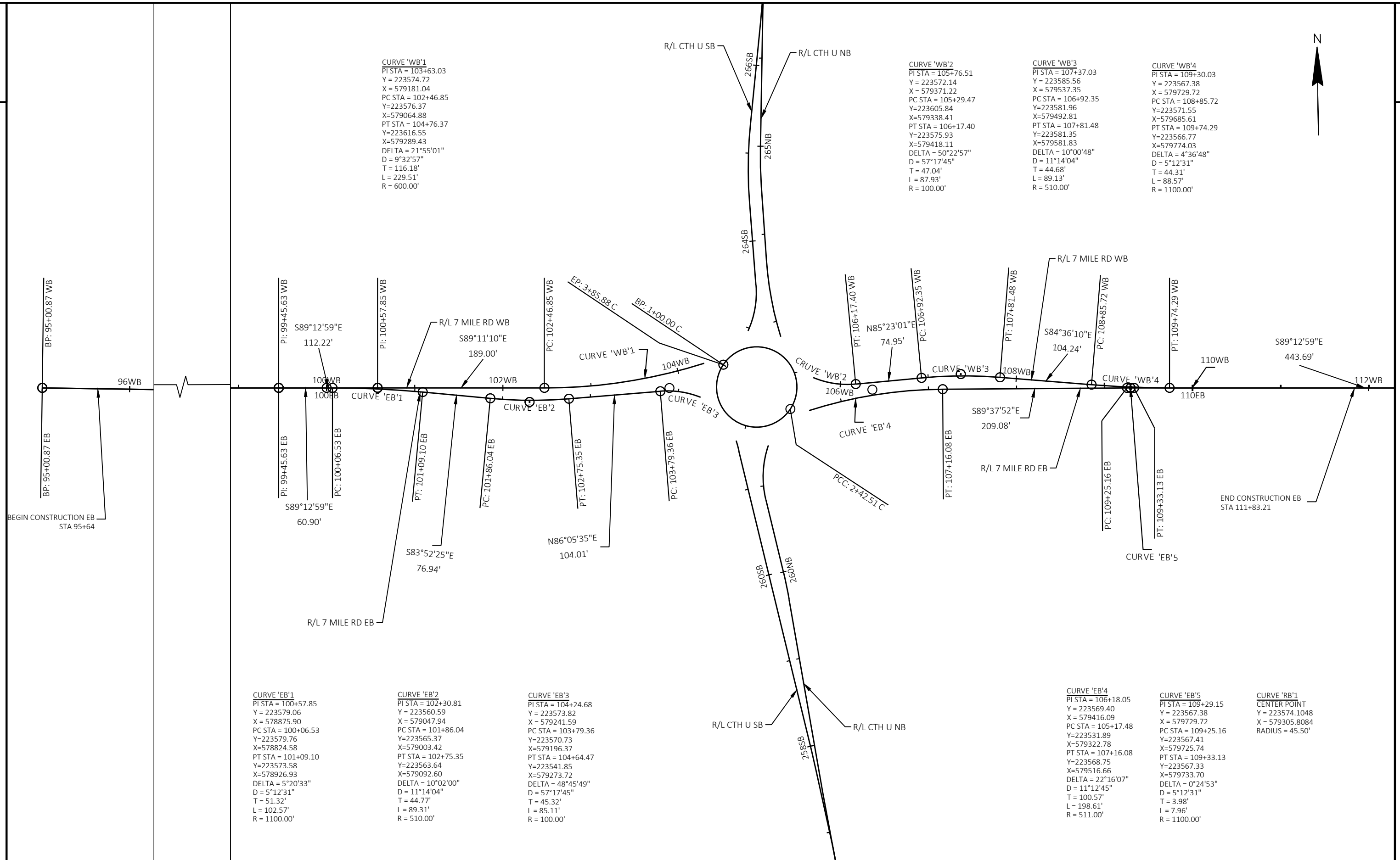

CURVE 'WB'1  
 PI STA = 103+63.03  
 Y = 223574.72  
 X = 579181.04  
 PC STA = 102+46.85  
 Y = 223576.37  
 X = 579064.88  
 PT STA = 104+76.37  
 Y = 223616.55  
 X = 579289.43  
 DELTA = 21°55'01"  
 D = 9°32'57"  
 T = 116.18'  
 L = 229.51'  
 R = 600.00'

CURVE 'WB'2  
 PI STA = 105+76.51  
 Y = 223572.14  
 X = 579371.22  
 PC STA = 105+29.47  
 Y = 223605.84  
 X = 579338.41  
 PT STA = 106+17.40  
 Y = 223575.93  
 X = 579418.11  
 DELTA = 50°22'57"  
 D = 57°17'45"  
 T = 47.04'  
 L = 87.93'  
 R = 100.00'

CURVE 'WB'3  
 PI STA = 107+37.03  
 Y = 223585.56  
 X = 579537.35  
 PC STA = 106+92.35  
 Y = 223581.96  
 X = 579492.81  
 PT STA = 107+81.48  
 Y = 223581.35  
 X = 579581.83  
 DELTA = 10°00'48"  
 D = 11°14'04"  
 T = 44.68'  
 L = 89.13'  
 R = 510.00'

CURVE 'WB'4  
 PI STA = 109+30.03  
 Y = 223567.38  
 X = 579729.72  
 PC STA = 108+85.72  
 Y = 223571.55  
 X = 579685.61  
 PT STA = 109+74.29  
 Y = 223566.77  
 X = 579774.03  
 DELTA = 4°36'48"  
 D = 5°12'31"  
 T = 44.31'  
 L = 88.57'  
 R = 1100.00'

CURVE 'EB'1  
 PI STA = 100+57.85  
 Y = 223579.06  
 X = 578875.90  
 PC STA = 100+06.53  
 Y = 223579.76  
 X = 578824.58  
 PT STA = 101+09.10  
 Y = 223573.58  
 X = 578926.93  
 DELTA = 5°20'33"  
 D = 5°12'31"  
 T = 51.32'  
 L = 102.57'  
 R = 1100.00'

CURVE 'EB'2  
 PI STA = 102+30.81  
 Y = 223560.59  
 X = 579047.94  
 PC STA = 101+86.04  
 Y = 223565.37  
 X = 579003.42  
 PT STA = 102+75.35  
 Y = 223563.64  
 X = 579092.60  
 DELTA = 10°02'00"  
 D = 11°14'04"  
 T = 44.77'  
 L = 89.31'  
 R = 510.00'

CURVE 'EB'3  
 PI STA = 104+24.68  
 Y = 223573.82  
 X = 579241.59  
 PC STA = 103+79.36  
 Y = 223570.73  
 X = 579196.37  
 PT STA = 104+64.47  
 Y = 223541.85  
 X = 579273.72  
 DELTA = 48°45'49"  
 D = 57°17'45"  
 T = 45.32'  
 L = 85.11'  
 R = 100.00'

CURVE 'EB'4  
 PI STA = 106+18.05  
 Y = 223569.40  
 X = 579416.09  
 PC STA = 105+17.48  
 Y = 223531.89  
 X = 579322.78  
 PT STA = 107+16.08  
 Y = 223568.75  
 X = 579516.66  
 DELTA = 22°16'07"  
 D = 11°12'45"  
 T = 100.57'  
 L = 198.61'  
 R = 511.00'

CURVE 'EB'5  
 PI STA = 109+29.15  
 Y = 223567.38  
 X = 579729.72  
 PC STA = 109+25.16  
 Y = 223567.41  
 X = 579725.74  
 PT STA = 109+33.13  
 Y = 223567.33  
 X = 579733.70  
 DELTA = 0°24'53"  
 D = 5°12'31"  
 T = 3.98'  
 L = 7.96'  
 R = 1100.00'

CURVE 'RB'1  
 CENTER POINT  
 Y = 223574.1048  
 X = 579305.8084  
 RADIUS = 45.50'

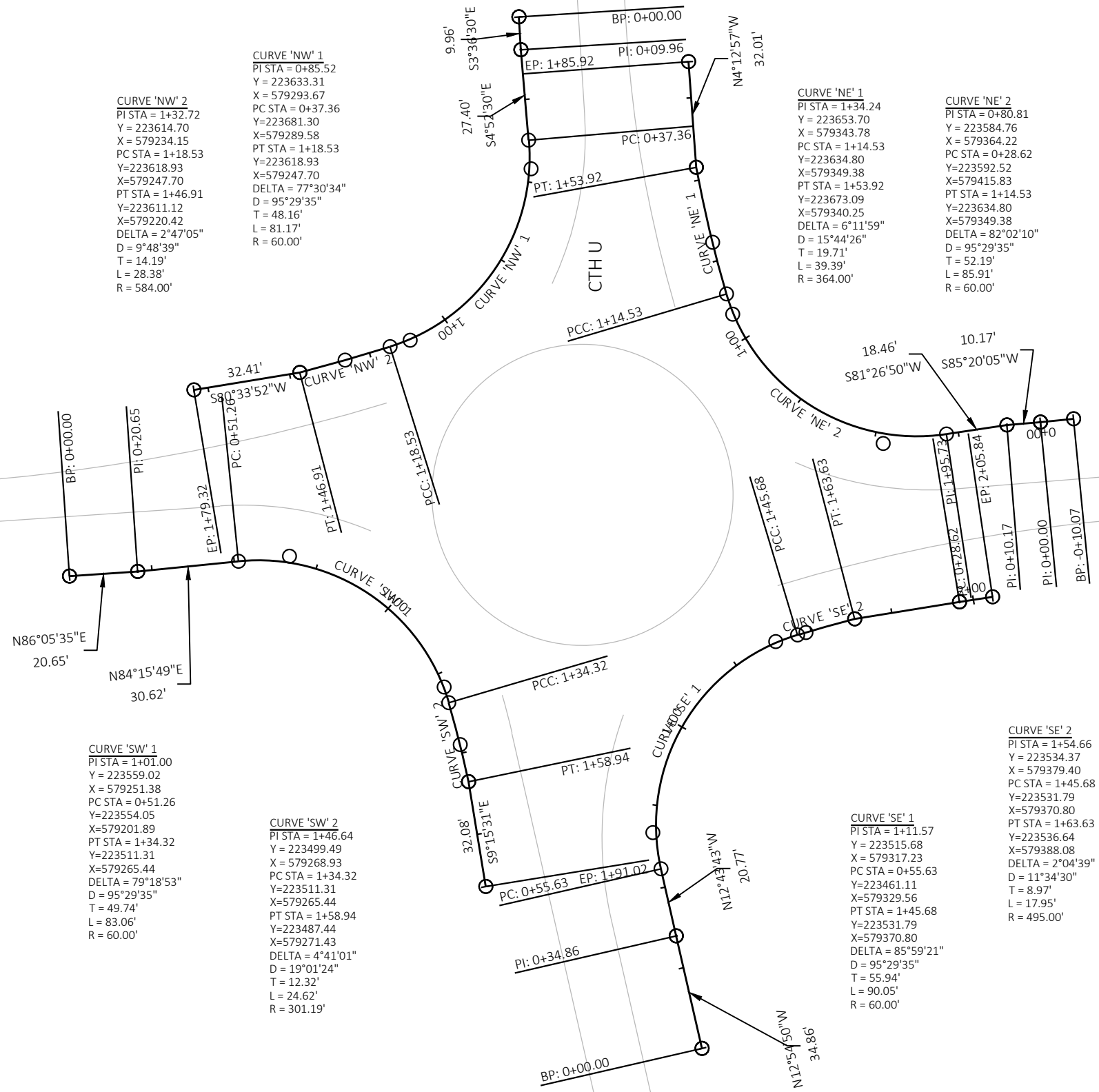

**CURVE 'NW' 1**  
 PI STA = 0+85.52  
 Y = 223633.31  
 X = 579293.67  
 PC STA = 0+37.36  
 Y = 223681.30  
 X = 579289.58  
 PT STA = 1+18.53  
 Y = 223618.93  
 X = 579247.70  
 DELTA = 77°30'34"  
 D = 95°29'35"  
 T = 48.16'  
 L = 81.17'  
 R = 60.00'

**CURVE 'NW' 2**  
 PI STA = 1+32.72  
 Y = 223614.70  
 X = 579234.15  
 PC STA = 1+18.53  
 Y = 223618.93  
 X = 579247.70  
 PT STA = 1+46.91  
 Y = 223611.12  
 X = 579220.42  
 DELTA = 2°47'05"  
 D = 9°48'39"  
 T = 14.19'  
 L = 28.38'  
 R = 584.00'

**CURVE 'NE' 1**  
 PI STA = 1+34.24  
 Y = 223653.70  
 X = 579343.78  
 PC STA = 1+14.53  
 Y = 223634.80  
 X = 579349.38  
 PT STA = 1+53.92  
 Y = 223673.09  
 X = 579340.25  
 DELTA = 6°11'59"  
 D = 15°44'26"  
 T = 19.71'  
 L = 39.39'  
 R = 364.00'

**CURVE 'NE' 2**  
 PI STA = 0+80.81  
 Y = 223584.76  
 X = 579364.22  
 PC STA = 0+28.62  
 Y = 223592.52  
 X = 579415.83  
 PT STA = 1+14.53  
 Y = 223634.80  
 X = 579349.38  
 DELTA = 82°02'10"  
 D = 95°29'35"  
 T = 52.19'  
 L = 85.91'  
 R = 60.00'

**CURVE 'SW' 1**  
 PI STA = 1+01.00  
 Y = 223559.02  
 X = 579251.38  
 PC STA = 0+51.26  
 Y = 223554.05  
 X = 579201.89  
 PT STA = 1+34.32  
 Y = 223511.31  
 X = 579265.44  
 DELTA = 79°18'53"  
 D = 95°29'35"  
 T = 49.74'  
 L = 83.06'  
 R = 60.00'

**CURVE 'SW' 2**  
 PI STA = 1+46.64  
 Y = 223499.49  
 X = 579268.93  
 PC STA = 1+34.32  
 Y = 223511.31  
 X = 579265.44  
 PT STA = 1+58.94  
 Y = 223487.44  
 X = 579271.43  
 DELTA = 4°41'01"  
 D = 19°01'24"  
 T = 12.32'  
 L = 24.62'  
 R = 301.19'

**CURVE 'SE' 1**  
 PI STA = 1+11.57  
 Y = 223515.68  
 X = 579317.23  
 PC STA = 0+55.63  
 Y = 223461.11  
 X = 579329.56  
 PT STA = 1+45.68  
 Y = 223531.79  
 X = 579370.80  
 DELTA = 85°59'21"  
 D = 95°29'35"  
 T = 55.94'  
 L = 90.05'  
 R = 60.00'

**CURVE 'SE' 2**  
 PI STA = 1+54.66  
 Y = 223534.37  
 X = 579379.40  
 PC STA = 1+45.68  
 Y = 223531.79  
 X = 579370.80  
 PT STA = 1+63.63  
 Y = 223536.64  
 X = 579388.08  
 DELTA = 2°04'39"  
 D = 11°34'30"  
 T = 8.97'  
 L = 17.95'  
 R = 495.00'

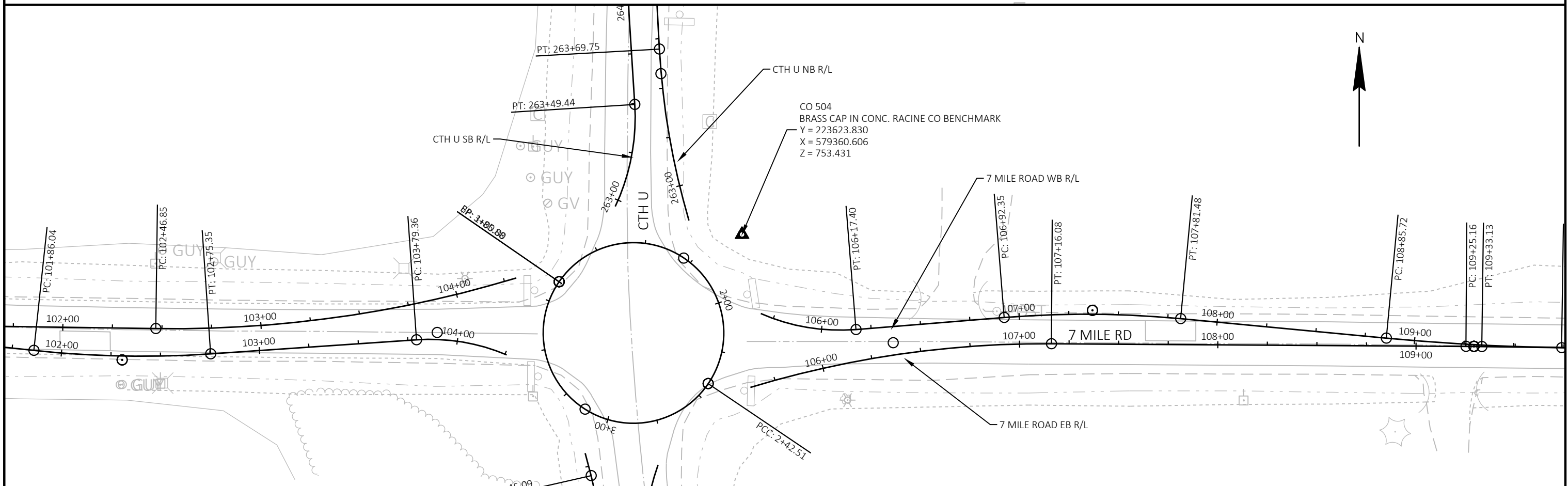
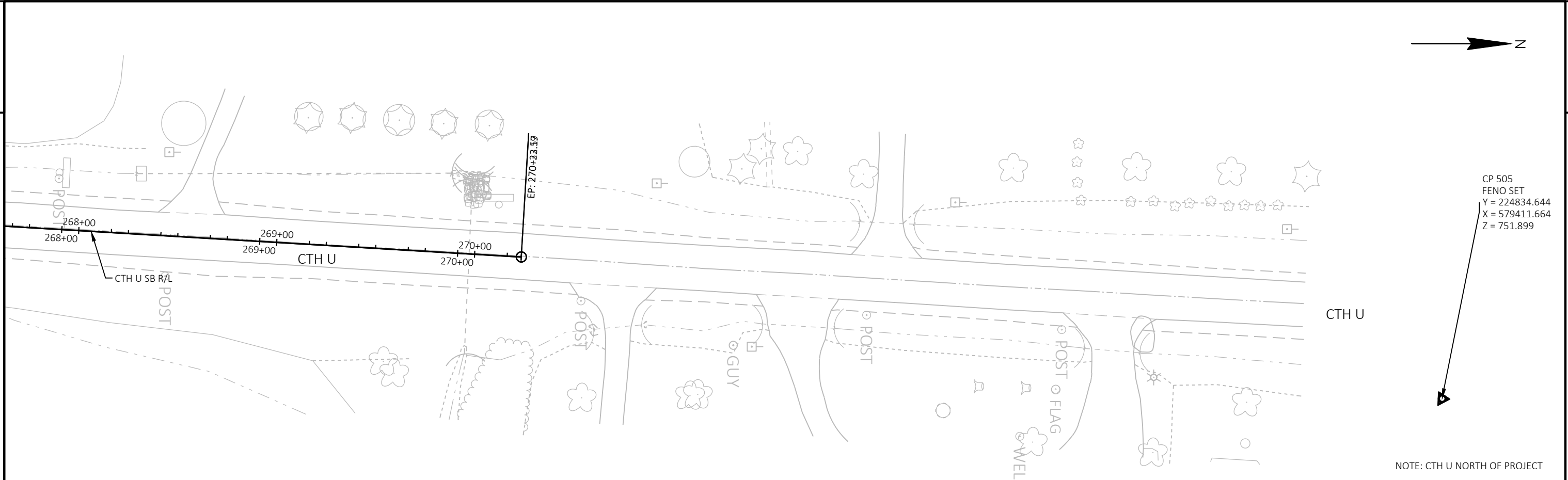

PROJECT NO: 2816-03-70	HWY: CTH U	COUNTY: RACINE	ALIGNMENT DETAILS SURVEY CONTROL	SHEET	E
------------------------	------------	----------------	----------------------------------	-------	---

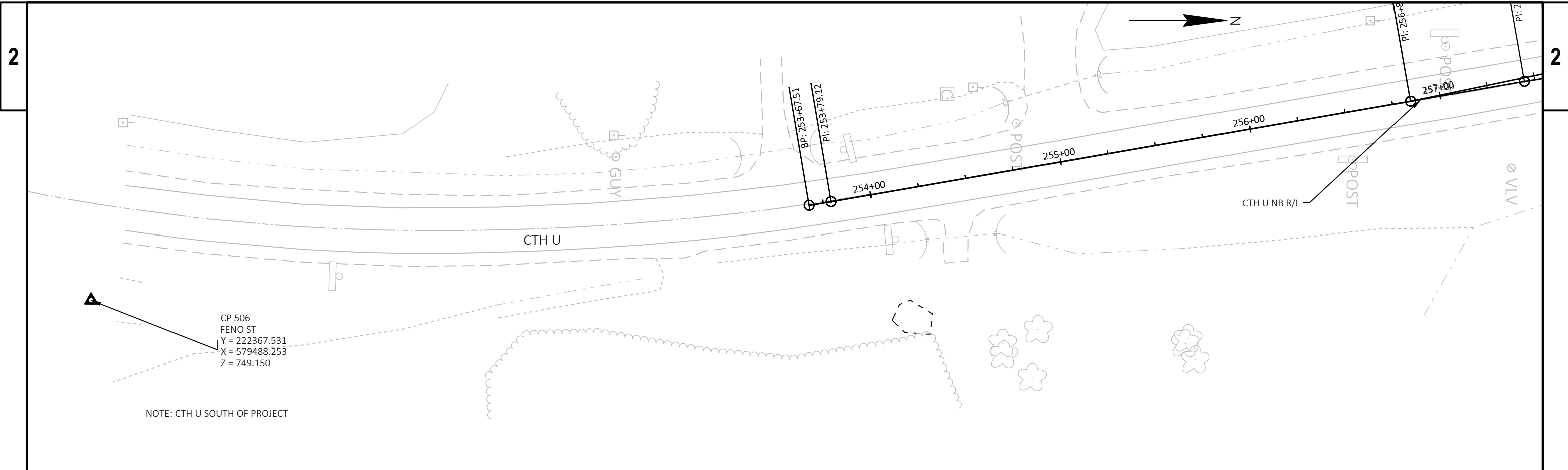

NOTE: CTH U SOUTH OF PROJECT

CP 506  
FENO ST  
Y = 222367.531  
X = 579488.253  
Z = 749.150

THIS SPACE INTENTIONALLY LEFT BLANK

Estimate Of Quantities

2816-03-70

Line	Item	Item Description	Unit	Total	Qty
0002	201.0205	Grubbing	STA	3.000	3.000
0004	203.0100	Removing Small Pipe Culverts	EACH	4.000	4.000
0006	204.0115	Removing Asphaltic Surface Butt Joints	SY	26.000	26.000
0008	204.0120	Removing Asphaltic Surface Milling	SY	80.000	80.000
0010	205.0100	Excavation Common	CY	10,190.000	10,190.000
0012	213.0100	Finishing Roadway (project) 01. 2816-03-70	EACH	1.000	1.000
0014	305.0110	Base Aggregate Dense 3/4-Inch	TON	429.000	429.000
0016	305.0120	Base Aggregate Dense 1 1/4-Inch	TON	8,883.000	8,883.000
0018	312.0110	Select Crushed Material	TON	9,965.000	9,965.000
0020	405.0100	Coloring Concrete WisDOT Red	CY	195.000	195.000
0022	415.2010	Concrete Truck Apron 12-inch	SY	584.000	584.000
0024	455.0605	Tack Coat	GAL	490.000	490.000
0026	460.2000	Incentive Density HMA Pavement	DOL	1,390.000	1,390.000
0028	460.5223	HMA Pavement 3 LT 58-28 S	TON	1,292.000	1,292.000
0030	460.5224	HMA Pavement 4 LT 58-28 S	TON	786.000	786.000
0032	465.0315	Asphaltic Flumes	SY	80.000	80.000
0034	522.0112	Culvert Pipe Reinforced Concrete Class III 12-Inch	LF	94.000	94.000
0036	522.0124	Culvert Pipe Reinforced Concrete Class III 24-Inch	LF	56.000	56.000
0038	522.1012	Apron Endwalls for Culvert Pipe Reinforced Concrete 12-Inch	EACH	10.000	10.000
0040	522.1024	Apron Endwalls for Culvert Pipe Reinforced Concrete 24-Inch	EACH	3.000	3.000
0042	601.0405	Concrete Curb & Gutter 18-Inch Type A	LF	185.000	185.000
0044	601.0411	Concrete Curb & Gutter 30-Inch Type D	LF	1,547.000	1,547.000
0046	601.0553	Concrete Curb & Gutter 4-Inch Sloped 36-Inch Type D	LF	1,223.000	1,223.000
0048	601.0557	Concrete Curb & Gutter 6-Inch Sloped 36-Inch Type D	LF	98.000	98.000
0050	601.0582	Concrete Curb & Gutter 4-Inch Sloped 36-Inch Type T	LF	273.000	273.000
0052	602.0405	Concrete Sidewalk 4-Inch	SF	9,880.000	9,880.000
0054	606.0200	Riprap Medium	CY	4.000	4.000
0056	608.0412	Storm Sewer Pipe Reinforced Concrete Class IV 12-Inch	LF	175.000	175.000
0058	608.0424	Storm Sewer Pipe Reinforced Concrete Class IV 24-Inch	LF	40.000	40.000
0060	611.0624	Inlet Covers Type H	EACH	8.000	8.000
0062	611.0627	Inlet Covers Type HM	EACH	3.000	3.000
0064	611.0652	Inlet Covers Type T	EACH	2.000	2.000
0066	611.3225	Inlets 2x2.5-FT	EACH	2.000	2.000
0068	611.3230	Inlets 2x3-FT	EACH	8.000	8.000
0070	612.0106	Pipe Underdrain 6-Inch	LF	198.000	198.000
0072	612.0700	Drain Tile Exploration	LF	400.000	400.000
0074	618.0100	Maintenance and Repair of Haul Roads (project) 01. 2816-03-70	EACH	1.000	1.000
0076	619.1000	Mobilization	EACH	1.000	1.000
0078	620.0300	Concrete Median Sloped Nose	SF	188.000	188.000
0080	624.0100	Water	MGAL	225.000	225.000
0082	625.0500	Salvaged Topsoil	SY	8,720.000	8,720.000
0084	628.1104	Erosion Bales	EACH	100.000	100.000
0086	628.1504	Silt Fence	LF	1,100.000	1,100.000
0088	628.1520	Silt Fence Maintenance	LF	1,100.000	1,100.000
0090	628.1530.S	Silt Fence Heavy Duty	LF	200.000	200.000
0092	628.1535.S	Silt Fence Heavy Duty Maintenance	LF	200.000	200.000
0094	628.1905	Mobilizations Erosion Control	EACH	5.000	5.000
0096	628.1910	Mobilizations Emergency Erosion Control	EACH	4.000	4.000
0098	628.2004	Erosion Mat Class I Type B	SY	11,490.000	11,490.000
0100	628.2023	Erosion Mat Class II Type B	SY	440.000	440.000

Estimate Of Quantities

2816-03-70

Line	Item	Item Description	Unit	Total	Qty
0102	628.7005	Inlet Protection Type A	EACH	10.000	10.000
0104	628.7020	Inlet Protection Type D	EACH	10.000	10.000
0106	628.7504	Temporary Ditch Checks	LF	420.000	420.000
0108	628.7555	Culvert Pipe Checks	EACH	13.000	13.000
0110	628.7560	Tracking Pads	EACH	4.000	4.000
0112	628.7570	Rock Bags	EACH	100.000	100.000
0114	629.0210	Fertilizer Type B	CWT	4.000	4.000
0116	630.0130	Seeding Mixture No. 30	LB	392.000	392.000
0118	630.0200	Seeding Temporary	LB	252.000	252.000
0120	630.0500	Seed Water	MGAL	252.000	252.000
0122	633.5200	Markers Culvert End	EACH	8.000	8.000
0124	634.0614	Posts Wood 4x6-Inch X 14-FT	EACH	4.000	4.000
0126	634.0616	Posts Wood 4x6-Inch X 16-FT	EACH	54.000	54.000
0128	634.0618	Posts Wood 4x6-Inch X 18-FT	EACH	5.000	5.000
0130	634.0622	Posts Wood 4x6-Inch X 22-FT	EACH	12.000	12.000
0132	637.2210	Signs Type II Reflective H	SF	461.000	461.000
0134	637.2230	Signs Type II Reflective F	SF	433.000	433.000
0136	638.2602	Removing Signs Type II	EACH	21.000	21.000
0138	638.3000	Removing Small Sign Supports	EACH	21.000	21.000
0140	642.5401	Field Office Type D	EACH	1.000	1.000
0142	643.0300	Traffic Control Drums	DAY	880.000	880.000
0144	643.0420	Traffic Control Barricades Type III	DAY	1,232.000	1,232.000
0146	643.0705	Traffic Control Warning Lights Type A	DAY	2,464.000	2,464.000
0148	643.0900	Traffic Control Signs	DAY	32,120.000	32,120.000
0150	643.0910	Traffic Control Covering Signs Type I	EACH	4.000	4.000
0152	643.0920	Traffic Control Covering Signs Type II	EACH	4.000	4.000
0154	643.1050	Traffic Control Signs PCMS	DAY	28.000	28.000
0156	643.5000	Traffic Control	EACH	1.000	1.000
0158	645.0120	Geotextile Type HR	SY	11.000	11.000
0160	646.1020	Marking Line Epoxy 4-Inch	LF	6,347.000	6,347.000
0162	646.3020	Marking Line Epoxy 8-Inch	LF	256.000	256.000
0164	646.6320	Marking Dotted Extension Epoxy 18-Inch	LF	38.000	38.000
0166	646.7120	Marking Diagonal Epoxy 12-Inch	LF	130.000	130.000
0168	646.8120	Marking Curb Epoxy	LF	112.000	112.000
0170	646.8220	Marking Island Nose Epoxy	EACH	4.000	4.000
0172	650.4000	Construction Staking Storm Sewer	EACH	15.000	15.000
0174	650.4500	Construction Staking Subgrade	LF	2,040.000	2,040.000
0176	650.5000	Construction Staking Base	LF	2,040.000	2,040.000
0178	650.5500	Construction Staking Curb Gutter and Curb & Gutter	LF	2,318.000	2,318.000
0180	650.6000	Construction Staking Pipe Culverts	EACH	4.000	4.000
0182	650.8501	Construction Staking Electrical Installations (project) 01. 2816-03-70	EACH	1.000	1.000
0184	650.9911	Construction Staking Supplemental Control (project) 01. 2816-03-70	EACH	1.000	1.000
0186	650.9920	Construction Staking Slope Stakes	LF	2,040.000	2,040.000
0188	652.0225	Conduit Rigid Nonmetallic Schedule 40 2-Inch	LF	1,268.000	1,268.000
0190	652.0235	Conduit Rigid Nonmetallic Schedule 40 3-Inch	LF	263.000	263.000
0192	653.0140	Pull Boxes Steel 24x42-Inch	EACH	12.000	12.000
0194	654.0105	Concrete Bases Type 5	EACH	12.000	12.000
0196	654.0224	Concrete Control Cabinet Bases Type L24	EACH	1.000	1.000
0198	655.0610	Electrical Wire Lighting 12 AWG	LF	1,548.000	1,548.000
0200	655.0620	Electrical Wire Lighting 8 AWG	LF	2,600.000	2,600.000

Estimate Of Quantities

2816-03-70

Line	Item	Item Description	Unit	Total	Qty
0202	656.0201	Electrical Service Meter Breaker Pedestal (location) 01. 263+33, 56.4' LT NB	EACH	1.000	1.000
0204	657.0255	Transformer Bases Breakaway 11 1/2-Inch Bolt Circle	EACH	12.000	12.000
0206	657.0322	Poles Type 5-Aluminum	EACH	12.000	12.000
0208	657.0615	Luminaire Arms Single Member 4 1/2-Inch Clamp 8-FT	EACH	12.000	12.000
0210	659.1115	Luminaires Utility LED A	EACH	12.000	12.000
0212	659.2124	Lighting Control Cabinets 120/240 24-Inch	EACH	1.000	1.000
0214	690.0150	Sawing Asphalt	LF	96.000	96.000
0216	ASP.1T0A	On-the-Job Training Apprentice at \$5.00/HR	HRS	1,300.000	1,300.000
0218	ASP.1T0G	On-the-Job Training Graduate at \$5.00/HR	HRS	900.000	900.000

CLEARING AND GRUBBING

CATEGORY	LOCATION	STATION	OFFSET	TO	STATION	OFFSET	ALIGNMENT	FOR INFORMATION ONLY CLEARING STA	201.0205 GRUBBING STA
0010	CTH U	260+67	45' LT	-	261+60	53' LT	CTH U SB	1	1
	7 MILE RD	103+13	25' RT	-	104+60	60' RT	7 MILE RD EB	2	2
PROJECT TOTAL								3	3

NOTE: CLEARING PERFORMED BY OTHERS

REMOVING SMALL PIPE CULVERTS

CATEGORY	LOCATION	STATION	OFFSET	ALIGNMENT	203.0100 REMOVING SMALL PIPE CULVERTS EACH	COMMENTS
0010	CTH U	260+97.83	29' RT	CTH U NB	1	15" x 28' CMCP
	7 MILE RD	109+18.67	23' RT	7 MILE RD EB	1	15" x 24' CMCP
	7 MILE RD	106+66.75	24' RT	7 MILE RD EB	1	18" x 29' CMCP
	7 MILE RD	100+81.47	0.45' LT	7 MILE RD EB	1	18" x 52' CMCP
PROJECT TOTAL					4	

FIELD OFFICE

CATEGORY	LOCATION	642.5401 FIELD OFFICE TYPE D EACH
0010	PROJECT	1
PROJECT TOTAL		1

REMOVAL ITEMS

CATEGORY	LOCATION	STATION	OFFSET	TO	STATION	OFFSET	ALIGNMENT	204.0120 REMOVING ASPHALTIC SURFACE MILLING SY
0010	7 MILE RD E	111+49.01	11' LT	-	111+84.04	11' RT	7 Mile Rd EB	40
	7 MILE RD W	95+64.15	11' RT	-	96+99.08	11' RT	7 Mile Rd EB	40
PROJECT TOTAL								80

FINISHING ROADWAY (PROJECT)

CATEGORY	LOCATION	213.0100 FINISHING ROADWAY (PROJECT) EACH
0010	PROJECT	1
PROJECT TOTAL		1

PROJECT NO: 2816-03-70

HWY: CTH U

COUNTY: RACINE

MISCELLANEOUS QUANTITIES

SHEET

E



ALIGNMENT	FROM/TO STATION	205.0100 COMMON EXCAVATION (1)		SALVAGED/UNUSABLE PAVEMENT MATERIAL	AVAILABLE MATERIAL (4)	UNEXPANDED FILL	EXPANDED FILL (5)	MASS ORDINATE +/- (6)	WASTE
		CUT (2)	EBS EXCAVATION (3)				FACTOR 1.15		
DIVISION 1									
CTH U NB	256+84.42/266+99.47	2,041	994	263	1,778	574	660	1,118	1,118
CTH U SB	256+84.42/267+37.88	1,547	936	110	1,437	407	468	969	969
7 MILE RD EB	100+00/109+73.46	919	775	220	699	999	1,149	-450	0
7 MILE RD WB	100+00/109+74.29	1,306	753	108	1,198	404	465	733	733
CENTER CIRCLE	1+00/03+50	458	461	273	185	1,125	1,294	-1,109	0
DIVISION 1 SUBTOTAL		6,271	3,919	974	5,297	3,509	4,035	1,262	2,820
GRAND TOTAL		6,271	3,919	974	5,297	3,509	4,035	1,262	2,820
TOTAL COMMON EXC		10,190							

NOTES:

- (1) COMMON EXCAVATION IS THE SUM OF THE CUT AND EBS EXCAVATION COLUMNS. ITEM NUMBER 205.0100
- (2) SALVAGED/UNUSABLE PAVEMENT MATERIAL IS INCLUDED IN CUT.
- (3) EBS EXCAVATION TO BE WASTED AND BACKFILLED WITH SELECT CRUSHED MATERIAL
- (4) AVAILABLE MATERIAL = CUT - SALVAGED/UNUSABLE PAVEMENT MATERIAL
- (5) EXPANDED FILL = (UNEXPANDED FILL) \* FILL FACTOR
- (6) THE MASS ORDINATE + OR - QTY CALCULATED FOR THE DIVISION. PLUS QUANTITY INDICATES AN EXCESS OF MATERIAL WITHIN THE DIVISION. MINUS INDICATES A SHORTAGE OF MATERIAL WITHIN THE DIVISION.
- (7) FACTORS USED TO COMPUTE ANTICIPATED WASTE AND THE COMPUTED WASTE VOLUME IDENTIFIED ARE FOR GENERAL INFORMATION ONLY. DOES NOT INCLUDE EBS EXCAVATION.

BASE AGGREGATE ITEMS

CATEGORY	LOCATION	STATION	TO	STATION	OFFSET	ALIGNMENT	305.0110	305.0120*	312.0110
							BASE AGGREGATE DENSE 3/4-INCH TON	BASE AGGREGATE DENSE 1 1/4-INCH TON	SELECT CRUSHED MATERIAL TON
0010	CTH U NORTH LEG	263+04	-	267+30	LT & RT	NB	108	1,957	2,157
	CTH U SOUTH LEG	256+85	-	261+50	LT & RT	NB	115	2,085	2,339
	7 MILE WEST LEG	100+00	-	104+50	LT & RT	EB	106	1,918	2,112
	7 MILE EAST LEG	105+75	-	109+75	LT & RT	EB	100	1,837	2,026
	CENTER CIRCLE	261+50	-	263+04	LT & RT	NB		998	1,331
PROJECT TOTAL							429	8,795	9,965

\*ADDITIONAL QUANTITIES SHOWN ELSEWHERE

DRIVEWAYS

CATEGORY	LOCATION	STATION	OFFSET	ALIGNMENT	305.0120*
					BASE AGGREGATE DENSE 1 1/4-INCH TON
0010	CTH U SOUTH LEG	260+32	LT	NB	26
	7 MILE EAST LEG	106+82	LT	EB	20
	7 MILE EAST LEG	109+18	RT	EB	42
PROJECT TOTAL					88

\*ADDITIONAL QUANTITIES SHOWN ELSEWHERE

ASPHALTIC ITEMS

CATEGORY	LOCATION	STATION	TO	STATION	ALIGNMENT	455.0605	460.5224	460.5223
						TACK COAT GAL	HMA PAVEMENT 4 LT 58-28 S TON	HMA PAVEMENT 3 LT 58-28 S TON
0010	CTH U NORTH LEG	263+04	-	267+30	NB	122	196	293
	CTH U SOUTH LEG	256+85	-	261+50	NB	132	212	317
	7 MILE WEST LEG	100+00	-	104+50	EB	118	189	284
	7 MILE EAST LEG	105+75	-	109+75	EB	112	179	268
	7 MILE REPAIR RUMBLE STRIP	95+64	-	99+99	EB	3	5	-
	7 MILE REPAIR RUMBLE STRIP	111+49	-	111+84	EB	3	5	-
	CENTER CIRCLE	261+50	-	263+04	NB	54	87	130
PROJECT TOTAL						490	786	1,292

CONCRETE PAVEMENT ITEMS

CATEGORY	LOCATION	405.0110	415.2010	620.0300	
		COLORING CONCRETE WISDOT RED	CONCRETE TRUCK APRON 12-INCH	CONCRETE MEDIAN SLOPED NOSE	
		CY	SY	Type 1 SF	Type 2 SF
0010	CTH U & 7 MILE RD	195	584	-	-
	CTH U SOUTH LEG	-	-	27	20
	CTH U NORTH LEG	-	-	27	20
	CTH U WEST LEG	-	-	27	20
	CTH U EAST LEG	-	-	27	20
PROJECT TOTAL		195	584	108	80

ASPHALTIC FLUMES

CATEGORY	LOCATION	STATION	OFFSET	ALIGNMENT	465.0315
					ASPHALTIC FLUMES SY
0010	CTH U SOUTH LEG	260+50	21' RT	NB	10
	CTH U SOUTH LEG	261+00	38' LT	NB	10
	CTH U NORTH LEG	263+56	21' RT	NB	10
	CTH U NORTH LEG	263+73	35' LT	NB	10
	7 MILE WEST LEG	103+43	19' RT	EB	10
	7 MILE WEST LEG	103+73	39' LT	EB	10
	7 MILE EAST LEG	106+15	23' RT	EB	10
	7 MILE EAST LEG	106+54	34' LT	EB	10
PROJECT TOTAL					80

CONCRETE CURB & GUTTER

CATEGORY	LOCATION	STATION	TO	STATION	OFFSET	ALIGNMENT	601.0405	601.0553	601.0411	601.0557	601.0582
							CONCRETE CURB & GUTTER 18-INCH TYPE A	CONCRETE CURB & GUTTER 4-INCH SLOPED 36-INCH TYPE	CONCRETE CURB & GUTTER 30-INCH TYPE	CONCRETE CURB & GUTTER 6-INCH SLOPED 36-INCH TYPE	CONCRETE CURB & GUTTER 4-INCH SLOPED 36-INCH TYPE
							D LF	D LF	D LF	D LF	T LF
0010	CTH U NORTH LEG	262+88	-	264+42	LT	NB	-	-	326	-	-
	CTH U NORTH LEG	264+42	-	265+30	LT	NB	-	178	-	24	-
	CTH U SOUTH LEG	259+05	-	260+49	LT	NB	-	289	-	25	-
	CTH U SOUTH LEG	260+49	-	261+48	LT	NB	-	-	229	-	-
	7 MILE EAST LEG	105+66	-	107+21	LT	EB	-	-	328	-	-
	7 MILE EAST LEG	107+21	-	108+00	LT	EB	-	160	-	24	-
	7 MILE WEST LEG	101+80	-	102+75	LT	EB	-	190	-	25	-
	7 MILE WEST LEG	102+75	-	104+26	LT	EB	-	-	328	-	-
	NE QUAD	262+40	-	263+16	RT	NB	-	91	-	-	-
	NE QUAD	263+17	-	263+58	RT	NB	-	-	34	-	-
	NE QUAD	106+29	-	106+54	LT	EB	-	-	34	-	-
	NW QUAD	262+72	-	263+27	LT	NB	-	108	-	-	-
	NW QUAD	263+27	-	263+73	LT	NB	-	-	49	-	-
	NW QUAD	103+74	-	104+06	LT	EB	-	-	49	-	-
	SE QUAD	105+84	-	106+15	RT	EB	-	-	45	-	-
	SE QUAD	260+50	-	261+13	RT	NB	-	-	46	-	-
	SE QUAD	261+13	-	261+70	RT	NB	-	98	-	-	-
	SW QUAD	260+98	-	261+26	LT	NB	-	-	40	-	-
	SW QUAD	261+26	-	262+00	LT	NB	-	109	-	-	-
	SW QUAD	103+43	-	103+80	RT	EB	-	-	39	-	-
	CENTER CIRCLE	261+74	-	262+68	LT	NB	-	-	-	-	273
	CENTER CIRCLE	261+95	-	262+53	LT	NB	185	-	-	-	-
CTH U & 7 MILE RD							185	1,223	1,547	98	273
PROJECT TOTAL							185	1,223	1,547	98	273

PROJECT NO: 2816-03-70

HWY: CTH U

COUNTY: RACINE

MISCELLANEOUS QUANTITIES

SHEET

E

**STORM SEWER STRUCTURES**

522.1012\*    522.1024\*    611.3230    611.3225    611.0624    611.0627    611.0652    633.5200  
 INLET COVERS

CATEGORY	LOCATION	STATION	OFFSET	ALIGNMENT	STRUCTURE NUMBER	RIM ELEVATION	BOTTOM OF STRUCTURE ELEVATION	DEPTH	522.1012*	522.1024*	611.3230	611.3225	611.0624	611.0627	611.0652	633.5200
									APRON ENDWALLS FOR CULVERT PIPE REINFORCED CONCRETE 12-INCH EACH	APRON ENDWALLS FOR CULVERT PIPE REINFORCED CONCRETE 24-INCH EACH	INLETS 2X3-FT EACH	INLETS 2X2.5-FT EACH	INLET COVERS TYPE H EACH	INLET COVERS TYPE HM EACH	INLET COVERS TYPE T EACH	MARKERS CULVERT END EACH
0010	CTH U SOUTH LEG	260+73	44.95' LT	NB	6-1	-	-	-	1	--	--	--	--	--	--	1
	CTH U SOUTH LEG	260+71	15.79' LT	NB	6-2	755.92	751.49	3.60	--	--	1	--	1	--	--	--
	CTH U SOUTH LEG	260+64	1.00' LT	NB	6-3	755.91	751.65	3.43	--	--	1	--	1	--	--	--
	CTH U NORTH LEG	265+21	9.95' LT	NB	7-1	751.82	748.56	2.43	--	--	1	--	1	--	--	--
	CTH U NORTH LEG	265+20	1.00' LT	NB	7-2	751.87	748.50	2.54	--	--	1	--	1	1	--	--
	CTH U NORTH LEG	265+20	23.84' RT	NB	7-3	-	-	-	1	--	--	--	--	--	--	1
	7 MILE WEST LEG	101+92	11.42' LT	EB	2-1	752.57	747.31	4.43	--	--	1	--	1	--	--	--
	7 MILE WEST LEG	101+92	2.57' LT	EB	2-2	752.50	747.22	4.45	--	--	1	--	1	1	--	--
	7 MILE WEST LEG	101+90	28.70' RT	EB	2-3	-	-	-	--	1	--	--	--	--	--	1
	7 MILE EAST LEG	107+89	10.56' LT	EB	4-1	751.29	748.59	1.87	--	--	1	--	1	--	--	--
	7 MILE EAST LEG	107+88	1.00' LT	EB	4-2	751.31	748.49	1.99	--	--	1	--	1	1	--	--
	7 MILE EAST LEG	107+88	22.21' RT	EB	4-3	-	-	-	1	--	--	--	--	--	--	1
	CENTER CIRCLE	262+41	1.12' LT	NB	3-1	755.46	751.93	2.62	--	--	--	--	--	--	1	--
	CENTER CIRCLE	262+57	4.62' LT	NB	3-2	755.32	751.85	2.56	--	--	--	1	--	--	1	--
	CENTER CIRCLE	262+82	31.90' RT	NB	3-3	-	-	-	1	--	--	1	--	--	--	--
PROJECT TOTAL									4	1	8	2	8	3	2	4

\*ADDITIONAL QUANTITIES SHOWN ELSEWHERE

NOTE

- 1) STATIONS SHOWN ARE TO THE CENTER OF STRUCTURE
- 2) OFFSETS ARE TO THE FLANGE LINE FOR STRUCTURES IN THE ROADWAY WITH INLET GRATES AND TO THE CENTER OF COVER FOR FIELD INLETS AND MANHOLES WITH SOLID LIDS
- 3) RIM ELEVATIONS ARE GIVEN AT THE FLANGE LINE FOR INLET GRATES OR THE CENTER OF THE MANHOLE COVER FOR MANHOLES
- 4) DEPTH = RIM ELEVATION - INVERT - CASTING HEIGHT - ADJUSTMENT  
 CASTING HEIGHT = 0.75 FT FOR J COVERS; 0.5 FT FOR HM AND S COVERS; 0.83 FT FOR TYPE V COVERS; 0.67 FOR TYPE B COVERS; 0 FT FOR TYPE MS COVERS  
 ADJUSTMENT (RINGS) = 0.33 FT FOR B, V, J, HM, AND S COVERS; 0 FT FOR TYPE MS COVERS

**CROSS DRAINS AND MINOR PRIVATE ENTRANCE DRAINS**

CATEGORY	LOCATION	STATION	OFFSET	TO	STATION	OFFSET	ALIGNMENT	INLET ELEVATION	DISCHARGE ELEVATION	SLOPE	522.0112	522.1012*	522.0124	522.1024	633.5200
											CULVERT PIPE REINFORCED CONCRETE CLASS III 12-INCH LF	APRON ENDWALLS FOR CULVERT PIPE REINFORCED CONCRETE 12-INCH EACH	CULVERT PIPE REINFORCED CONCRETE CLASS III 24-INCH LF	APRON ENDWALLS FOR CULVERT PIPE REINFORCED CONCRETE 24-INCH EACH	MARKERS CULVERT END EACH
0010	CTH U SOUTH LEG EXISTING	257+58	49' LT	-	257+59	44' RT	NB	--	--	--	--	--	--	--	2
	CTH U SOUTH LEG DWY	260+14	62' LT	-	260+48	70' LT	NB	750.09	749.69	1.21%	33	2	--	--	--
	7 MILE WEST LEG	100+80	27' LT	-	100+84	29' RT	EB	747.42	746.56	1.55%	--	--	56	2	2
	7 MILE EAST LEG DWY	106+70	48' LT	-	106+98	47' LT	EB	750.62	750.14	1.69%	29	2	--	--	--
	7 MILE EAST LEG DWY	109+01	31' RT	-	109+33	28' RT	EB	746.66	746.34	1.01%	32	2	--	--	--
PROJECT TOTAL											94	6	56	2	4

\*ADDITIONAL QUANTITIES SHOWN ELSEWHERE

NOTE

- 1) STATION OFFSETS SHOWN ARE TO THE CENTER OF INLET STRUCTURES OR END OF PIPE AT APRON ENDWALLS (NOT INCLUDING LENGTH OF ENDWALL).

STORM SEWER ITEMS

CATEGORY	LOCATION	STRUCTURE	TO	STRUCTURE	INLET ELEVATION	DISCHARGE ELEVATION	SLOPE	608.0412	608.0424	612.0106
								STORM SEWER PIPE	STORM SEWER PIPE	PIPE UNDERDRAIN
								REINFORCED CONCRETE CLASS IV 12-INCH	REINFORCED CONCRETE CLASS IV 24-INCH	6-INCH
LF	LF	LF								
0010	CTH U SOUTH LEG	--	--	--	--	--	--	--	--	28
	CTH U SOUTH LEG	6-3	--	6-2	751.64	751.51	0.96%	17	--	--
	CTH U SOUTH LEG	6-2	--	6-1	751.47	751.21	0.97%	29	--	--
	CTH U NORTH LEG	7-1	--	7-2	748.55	748.51	0.71%	9	--	--
	CTH U NORTH LEG	7-2	--	7-3	748.49	748.32	0.72%	25	--	--
	7-MILE WEST LEG	2-1	--	2-2	747.29	747.24	0.99%	--	9	--
	7-MILE WEST LEG	2-2	--	2-3	747.21	746.93	0.95%	--	31	--
	7 MILE EAST LEG	4-1	--	4-2	748.58	748.54	0.61%	10	--	--
	7 MILE EAST LEG	4-2	--	4-3	748.48	748.33	0.71%	23	--	--
	CENTER CIRCLE	3-1	--	3-2	751.90	751.88	0.54%	16	--	--
	CENTER CIRCLE	3-2	--	3-3	751.84	751.60	0.54%	46	--	--
	CENTER CIRCLE	--	--	--	--	--	--	--	--	170
	PROJECT TOTAL							175	40	198

NOTE: DISCHARGE ELEVATIONS ARE TO THE END OF PIPE, NOT THE END OF APRON ENDWALL

INLET PROTECTION

CATEGORY	LOCATION	STATION	OFFSET	ALIGNMENT	628.7005	628.7020
					INLET PROTECTION TYPE A EACH	INLET PROTECTION TYPE D EACH
0010	CTH U SOUTH LEG	260+71	16' LT	NB	1	1
	CTH U SOUTH LEG	260+64	1' LT	NB	1	1
	CTH U NORTH LEG	265+21	10' LT	NB	1	1
	CTH U NORTH LEG	265+20	1' LT	NB	1	1
	7 MILE WEST LEG	101+89	11' LT	EB	1	1
	7 MILE WEST LEG	101+90	2' LT	EB	1	1
	7 MILE EAST LEG	107+89	10' LT	EB	1	1
	7 MILE EAST LEG	107+88	1' LT	EB	1	1
	CENTER CIRCLE	262+56	5' LT	NB	1	1
	CENTER CIRCLE	262+41	1' LT	NB	1	1
	PROJECT TOTAL				10	10

DRAIN TILE ITEMS

CATEGORY	LOCATION	STATION	TO	STATION	ALIGNM ENT	612.0700
						DRAIN TILE EXPLORATION LF
0010	CTH U SOUTH LEG	257+00	-	259+00	NB	200
	7 MILE WEST LEG	100+00	-	102+00	EB	200
	PROJECT TOTAL					400

PROJECT NO: 2816-03-70

HWY: CTH U

COUNTY: RACINE

MISCELLANEOUS QUANTITIES

SHEET

E

3

RIPRAP ITEMS

CATEGORY	LOCATION	STATION	OFFSET	ALIGNMENT	606.0200 RIPRAP MEDIUM CY	645.0120 GEOTEXTILE TYPE HR SY
0010	CTH U & 7 MILE RD	100+75	34' LT	EB	4	11
PROJECT TOTAL					4	11

CONCRETE SIDEWALK

CATEGORY	LOCATION	602.0405 CONCRETE SIDEWALK 4-INCH SF	COMMENTS
0010	CTH U & 7 MILE RD	9,880	MEDIANS
PROJECT TOTAL		9,880	

3

RESTORATION ITEMS

CATEGORY	STAGE	LOCATION	625.0500 SALVAGED TOPSOIL SY	629.0210 FERTILIZER TYPE B CWT	630.0130 SEEDING MIXTURE NO. 30 LB	630.02 SEEDING TEMPORARY LB	630.0500 SEED WATER MGAL
0010	1	CTH U & 7 MILE RD	8,720	4.0	392	252	252
PROJECT TOTAL			8,720	4	392	252	252

EROSION CONTROL MOBILIZATION

CATEGORY	LOCATION	628.1905 MOBILIZATIONS EROSION CONTROL EACH	628.1910 MOBILIZATIONS EMERGENCY EROSION CONTROL EACH
0010	UNDISTRIBUTED	5	4
PROJECT TOTAL		5	4

PROJECT NO: 2816-03-70

HWY: CTH U

COUNTY: RACINE

MISCELLANEOUS QUANTITIES

SHEET

E

**EROSION CONTROL ITEMS**

CATEGORY	LOCATION	STATION	OFFSET	TO	STATION	OFFSET	ALIGNMENT	628.1104 EROSION BALES EACH	628.1504 SILT FENCE LF	628.1520 SILT FENCE MAINTENANCE LF	628.2004 EROSION MAT CLASS I TYPE B SY	628.2023 EROSION MAT CLASS II TYPE B SY	628.7504 TEMPORARY DITCH CHECKS LF	628.7555 CULVERT PIPE CHECKS EACH	628.7570 ROCK BAGS EACH	628.1530.S SILT FENCE HEAVY DUTY LF	628.1535.S SILT FENCE HEAVY DUTY MAINTENANCE LF
0010	7 MILE WEST LEG	101+53	44' RT	-	102+99	44' RT	EB	-	-	-	-	-	-	-	-	160	160
	7 MILE WEST LEG	100+00	34' RT	-	261+00	71' LET	EB/NB	-	480	480	-	-	-	-	-	-	-
	CTH U SOUTH LEG	256+85	66' RT	-	259+01	58' RT	NB	-	220	220	-	-	-	-	-	-	-
	CTH U SOUTH LEG	259+91	47' RT	-	260+79	48' RT	NB	-	100	100	-	-	-	-	-	-	-
	CTH U SOUTH LEG	256+83	42' LT	-	257+57	47' LT	NB	-	80	80	-	-	-	-	-	-	-
	CTH U SOUTH LEG	257+57	47' LT	-	-	-	NB	-	-	-	-	-	-	3	-	-	-
	CTH U SOUTH LEG	258+86	33' LT	-	-	-	NB	-	-	-	-	-	30	-	-	-	-
	CTH U SOUTH LEG	258+93	37' RT	-	-	-	NB	-	-	-	-	-	30	-	-	-	-
	CTH U SOUTH LEG	269+55	58' LT	-	-	-	NB	-	-	-	-	-	-	1	-	-	-
	CTH U SOUTH LEG	261+21	63' RT	-	-	-	NB	-	-	-	-	-	-	1	-	-	-
	CTH U NORTH LEG	263+12	71' LT	-	-	-	NB	-	-	-	-	-	30	-	-	-	-
	CTH U NORTH LEG	262+98	37' RT	-	-	-	NB	-	-	-	-	-	30	-	-	-	-
	CTH U NORTH LEG	264+99	41' LT	-	-	-	NB	-	-	-	-	-	30	-	-	-	-
	CTH U NORTH LEG	264+92	58' LT	-	-	-	NB	-	-	-	-	-	30	-	-	-	-
	CTH U NORTH LEG	265+52	35' LT	-	-	-	NB	-	-	-	-	-	30	-	-	-	-
	7 MILE WEST LEG	100+75	34' LT	-	-	-	EB	-	-	-	-	-	-	3	-	-	-
	7 MILE WEST LEG	102+02	37' RT	-	-	-	EB	-	-	-	-	-	30	-	-	-	-
	7 MILE WEST LEG	102+53	52' LT	-	-	-	EB	-	-	-	-	-	30	-	-	-	-
	7 MILE EAST LEG	106+64	43' LT	-	-	-	EB	-	-	-	-	-	-	1	-	-	-
	7 MILE EAST LEG	107+04	22' RT	-	-	-	EB	-	-	-	-	-	30	-	-	-	-
	7 MILE EAST LEG	107+67	43' LT	-	-	-	EB	-	-	-	-	-	30	-	-	-	-
	7 MILE EAST LEG	108+94	23' RT	-	-	-	EB	-	-	-	-	-	-	1	-	-	-
	CTH U & 7 MILE RD	-	-	-	-	-	-	-	-	-	9,190	350	-	-	-	-	-
	UNDISTRIBUTED							100	220	220	2,300	90	90	3	100	40	40
	PROJECT TOTAL							100	1,100	1,100	11,490	440	420	13	100	200	200

NOTE:

1. ROCK BAGS TO BE USED FOR SILT FENCE RELIEF AND AS DIRECTED BY THE ENGINEER

FOR INFORMATION ONLY	
ESTIMATED BAG SIZE = 18" X 12" X 6"	
PIPE SIZE	ESTIMATED NUMBER OF BAGS
12"	1
15"	2
18"	2
24"	3
30"	5

PROJECT NO: 2816-03-70

HWY: CTH U

COUNTY: RACINE

MISCELLANEOUS QUANTITIES

SHEET

E

TYPE II SIGNS AND SUPPORTS

CATEGORY	SIGN NUMBER	SIGN CODE	SIGN SIZE	SIGN TYPE	SIGN DIMENSION W X H			DESCRIPTION	634.0614	634.0616	634.0618	634.0622	637.2210	637.2230	SIGN MOUNTED ON SAME POST AS SIGN NO.
					POSTS WOOD 4X6-INCH X 14-FT EACH	POSTS WOOD 4X6-INCH X 16-FT EACH	POSTS WOOD 4X6-INCH X 18-FT EACH		POSTS WOOD 4X6-INCH X 22-FT EACH	SIGNS TYPE II REFLECTIVE H SF	SIGNS TYPE II REFLECTIVE F SF				
0010	201	R5-1	2S	II	30	X	30	DO NOT ENTER	--	2	--	--	6.25	--	202
	202	R2-1	2S	II	24	X	30	SPEED LIMIT 45	--	2	--	--	5.00	--	--
	203	W2-6	2S	II	30	X	30		--	2	--	--	--	6.25	204
	204	W13-1	2S	II	18	X	18	15 MPH	--	2	--	--	--	2.25	--
	205	W3-2	2S	II	36	X	36	YIELD AHEAD	--	2	--	--	--	9.00	--
	206	M1-5-A	2S	II	24	X	24	COUNTY U	--	1	--	--	--	4.00	--
	207	W6-3	2S	II	36	X	36	TWO-WAY TRAFFIC	--	1	--	--	--	9.00	--
	208	R4-7	2S	II	24	X	30		--	1	--	--	5.00	--	210
	209	W5-54	2S	II	18	X	18		--	1	--	--	--	2.25	--
	210	W14-3	2S	II	48	X	36	NO PASSING ZONE	--	1	--	--	--	5.56	--
	211	R1-2	2S	II	36	X	31	YIELD	--	1	--	--	3.88	--	213
	212	R1-54	2S	II	24	X	15	TO TRAFFIC FROM LEFT	1	--	--	--	2.50	--	--
	213	R1-2	2S	II	36	X	31	YIELD	--	--	1	--	3.88	--	215
	214	R6-2R	2S	II	24	X	30	ONE WAY RIGHT	--	1	--	--	5.00	--	--
	215	D1-2	2S	II	66	X	30	U SOUTH 76TH ST	--	1	--	--	13.75	--	--
	216	D1-2	2S	II	84	X	30	W 7 MILE ROAD	--	1	--	--	17.50	--	--
	217	R1-2	2S	II	36	X	31	YIELD	--	1	--	--	7.75	--	219
	218	R6-2R	2S	II	24	X	30	ONE WAY	--	1	--	--	5.00	--	--
	219	R1-2	2S	II	36	X	31	YIELD	--	1	--	--	7.75	--	221
	220	R1-54	2S	II	24	X	15	TO TRAFFIC FROM LEFT	1	--	--	--	2.50	--	--
	221	W14-3	2S	II	48	X	36	NO PASSING ZONE	--	1	--	--	--	5.56	223,224
	222	R4-7	2S	II	24	X	30		--	1	--	--	5.00	--	--
	223	W5-54	2S	II	18	X	18		--	1	--	--	--	2.25	--
	224	R2-1	2S	II	24	X	30	SPEED LIMIT 45	--	1	--	--	5.00	--	226
	225	R5-1	2S	II	30	X	30	DO NOT ENTER	--	1	--	--	6.25	--	--
	226	W6-3	2S	II	36	X	36		--	1	--	--	--	9.00	--
	228	W3-2	2S	II	30	X	30		--	1	--	--	--	6.25	230
	229	W13-1	2S	II	18	X	18	15 MPH	--	1	--	--	--	2.25	--
	230	W2-6	2S	II	30	X	30		--	1	--	--	--	6.25	--
	231	D1-2	2S	II	84	X	30	W 7 MILE ROAD	--	1	--	--	17.50	--	--
	232	R1-2	2S	II	36	X	31	YIELD	--	--	1	--	7.75	--	233
	233	R6-2R	2S	II	24	X	30	ONE WAY	--	1	--	--	5.00	--	--
	234	R1-2	2S	II	36	X	31	YIELD	--	--	1	--	7.75	--	235
	235	R1-54	2S	II	24	X	15	TO TRAFFIC FROM LEFT	1	--	--	--	2.50	--	--
	236	W14-3	2S	II	48	X	36	NO PASSING ZONE	--	1	--	--	--	5.56	237
	237	R4-7	2S	II	24	X	30		--	1	--	--	5.00	--	--
	238	W5-54	2S	II	18	X	18		--	1	--	--	--	2.25	237
	239	R2-1	2S	II	24	X	30	SPEED LIMIT 45	--	1	--	--	5.00	--	240
	240	R5-1	2S	II	30	X	30	DO NOT ENTER	--	1	--	--	6.25	--	--
	241	W6-3	2S	II	36	X	36		--	1	--	--	--	9.00	--
	242	M1-5A	2S	II	24	X	24	COUNTY U	--	1	--	--	4.00	--	--
	243	W3-2	2S	II	30	X	30		--	1	--	--	--	6.25	--
	244	W13-1	2S	II	18	X	18	15 MPH	--	1	--	--	--	2.25	243
	245	W2-6	2S	II	30	X	30		--	1	--	--	--	6.25	--
	247	R1-2	2S	II	36	X	31	YIELD	--	--	1	--	3.88	--	246
	248	R6-2R	2S	II	24	X	30	ONE WAY	--	1	--	--	5.00	--	--
	249	R1-2	2S	II	36	X	31	YIELD	--	--	1	--	3.88	--	--
	250	R1-54	2S	II	24	X	15	TO TRAFFIC FROM LEFT	1	--	--	--	2.50	--	--
	251	W14-3	2S	II	48	X	36	NO PASSING ZONE	--	1	--	--	--	5.56	250
	252	R4-7	2S	II	24	X	30		--	1	--	--	5.00	--	251
	253	W5-54	2S	II	18	X	18		--	1	--	--	--	2.25	250
	254	R2-1	2S	II	24	X	30	SPEED LIMIT 45	--	1	--	--	5.00	--	253
	255	R5-1	2S	II	30	X	30	DO NOT ENTER	--	1	--	--	6.25	--	--
	256	W6-3	2S	II	36	X	36		--	1	--	--	--	9.00	--
	257	D1-2	2S	II	60	X	30	U NORTH 76TH ST	--	1	--	--	13.75	--	--
	258	W3-2	2S	II	30	X	30		--	1	--	--	--	6.25	257
	259	W13-1	2S	II	18	X	18		--	1	--	--	--	2.25	--
	260	W2-6	2S	II	30	X	30		--	1	--	--	--	6.25	--
	261	D1-62	-	II	144	X	66		--	--	--	3	66.00	--	--
	262	D1-62	-	II	144	X	66		--	--	--	3	66.00	--	--
	263	D1-62	-	II	144	X	60		--	--	--	3	60.00	--	--
	264	D1-62	-	II	144	X	60		--	--	--	3	60.00	--	--
PROJECT TOTAL								4	54	5	12	461	133		

PROJECT NO: 2816-03-70

HWY: CTH U

COUNTY: RACINE

MISCELLANEOUS QUANTITIES

SHEET

E

REMOVING SIGNS

CATEGORY	LOCATION	SIGN NUMBER	SIGN CODE	SIGN MESSAGE	638.2602	638.3000
					REMOVING SIGNS TYPE II	REMOVING SMALL SIGN SUPPORTS
					EACH	EACH
0010	CTH U & 7 MILE RD	1R	W1-2-R	--	1	1
		2R	W2-1	--	1	1
		3R	D1-60	W 7 MILE ROAD	1	1
		4R	W1-2-R	--	1	1
		5R	R2-1	45 MPH	1	1
		6R	R1-1	STOP	1	1
		7R	R1-1	STOP	1	1
		8R	R1-1	STOP	1	1
		9R	R1-1	STOP	1	1
		10R	R2-1	45 MPH	1	1
		11R	W1-2-L	--	1	1
		12R	W 7 MILE RD	D1-60	1	1
		14R	W2-1	--	1	1
		15R	W3-1	--	1	1
		16R	W3-1	--	1	1
		17R	W3-1 & R2-1	45 MPH	2	1
		18R	W3-1	--	1	1
		19R	W3-1	--	1	1
		20R	W3-1	--	1	1
		21R	D1-601	WAUKESHA RD	1	2
		PROJECT TOTAL				

LONG LINE PAVEMENT MARKING ITEMS

CATEGORY	STAGE	LOCATION	STATION	TO	STATION	ALIGNMENT	646.1020			646.3020	646.6320	646.7120	646.8120	646.8220
							MARKING LINE EPOXY 4-INCH			MARKING LINE EPOXY 8-INCH	MARKING DOTTED EXTENSION EPOXY 18-INCH 3' LINE 9' SKIP WHITE	MARKING DIAGONAL EPOXY 12-INCH	MARKING CURB EPOXY	MARKING ISLAND NOSE EPOXY
							3' LINE 9' SKIP WHITE	DOUBLE YELLOW	SOLID WHITE	SOLID WHITE	(YELLOW)	(YELLOW)	(YELLOW)	
							LF	LF	LF	LF	LF	LF	EACH	
0010	1	7 MILE RD W	100+00	-	104+24	EB	32	749	729	64	9	33	27	1
		CTH U N	262+80	-	267+32	NB	36	891	730	66	9	30	29	1
		7 MILE RD E	105+60	-	109+75	EB	32	727	671	64	9	32	28	1
		CTH U S	256+85	-	261+50	NB	29	920	801	61	11	35	29	1
PROJECT TOTAL							129	3,287	2,931	256	38	130	112	4
								6,347		256	38	130	112	4

PROJECT NO: 2816-03-70

HWY: CTH U

COUNTY: RACINE

MISCELLANEOUS QUANTITIES

SHEET

E



3

LIGHTING-POLES

POLE I.D. OR LOCATION	657.0255	657.0322	654.0105
	TRANSFORMER BASES BREAKAWAY 11.5-INCH BOLT CIRCLE EACH	POLES TYPE 5 ALUMINUM EACH	CONCRETE BASES TYPE 5 EACH
BXX1	1	1	1
AXX2	1	1	1
BXX3	1	1	1
AXX4	1	1	1
BXX5	1	1	1
AXX6	1	1	1
BXX7	1	1	1
AXX8	1	1	1
BXX9	1	1	1
AXX10	1	1	1
BXX11	1	1	1
AXX12	1	1	1
TOTALS	12	12	12

LIGHTING-MISCELLANEOUS

DESCRIPTION	654.0224	656.0201	659.2124
	CONCRETE CONTROL CABINET BASES TYPE L24 EACH	ELECTRICAL SERVICE METER BREAKER PEDESTAL EACH	LIGHTING CONTROL CABINETS 120/240 24-INCH EACH
263+33, 56.4' LT NB	1	1	1
TOTALS	1	1	1

3

LIGHTING-ARMS AND LUMINAIRES

POLE I.D. OR LOCATION	655.0610	657.0615	659.1115
	ELECTRICAL WIRE LIGHTING 12 AWG LF	LUMINAIRE ARMS SINGLE MEMBER 4 1/2-INCH CLAMP 8-FT EACH	LUMINAIRES UTILITY LED A EACH
BXX1	129	1	1
AXX2	129	1	1
BXX3	129	1	1
AXX4	129	1	1
BXX5	129	1	1
AXX6	129	1	1
BXX7	129	1	1
AXX8	129	1	1
BXX9	129	1	1
AXX10	129	1	1
BXX11	129	1	1
AXX12	129	1	1
TOTALS	1,548	12	12

LIGHTING-PULL BOXES

DESCRIPTION	STATION	OFFSET	ALIGNMENT	653.0140 PULL BOXES STEEL 24X42-INCH EACH
PB1	263+30.62	41.5' LT	NB	1
PB2	264+97.85	41' LT	NB	1
PB3	262+18.08	22' RT	NB	1
PB4	106+18.33	42' LT	EB	1
PB5	107+63.63	40' LT	EB	1
PB6	106+03.97	24' RT	EB	1
PB7	260+98.69	24' RT	NB	1
PB8	259+98.40	26' RT	NB	1
PB9	261+01.10	24' LT	NB	1
PB10	103+79.40	22' RT	EB	1
PB11	102+71.40	23' RT	EB	1
PB12	102+84.65	42' LT	EB	1
TOTAL				12

PROJECT NO: 2816-03-70

HWY: CTH U

COUNTY: RACINE

MISCELLANEOUS QUANTITIES

SHEET

E

LIGHTING-WIRE AND CONDUIT

FROM	TO	652.0225 CONDUIT RIGID NONMETALLIC SCHEDULE 40 2-INCH LF	652.0235 CONDUIT RIGID NONMETALLIC SCHEDULE 40 3-INCH LF	655.0620 ELECTRICAL WIRE LIGHTING 8 AWG LF
DC	PB1	16	-	124
PB1	BCTHU1	64	-	276
BCTHU1	PB2	112	-	508
PB2	ACTHU2	60	-	260
PB1	PB3	-	65	320
PB3	BCTHU3	8	-	52
PB3	PB4	97	-	448
PB4	ACTHU4	23	-	112
ACTHU4	PB5	110	-	500
PB5	BCTHU5	84	-	356
PB4	PB6	-	67	328
PB6	ACTHU6	20	-	100
PB1	ACTHU12	83	-	352
ACTHU12	PB12	20	-	140
PB12	PB10	-	65	320
PB10	ACTHU10	56	-	244
ACTHU10	PB11	54	-	276
PB11	BCTHU11	128	-	532
PB10	BCTHU9	87	-	368
BCTHU9	PB9	33	-	192
PB9	PB7	-	66	324
PB7	BCTHU7	20	-	100
BCTHU7	PB8	79	-	376
PB8	ACTHU8	114	-	476
TOTALS		1,268	263	2,600

**TRAFFIC CONTROL ITEMS-DETOUR**

CATEGORY	LOCATION	DURATION	643.0300		643.0420		643.0705		643.0900	
			TRAFFIC CONTROL DRUMS		TRAFFIC CONTROL BARRICADES TYPE III		TRAFFIC CONTROL WARNING LIGHTS TYPE A		TRAFFIC CONTROL SIGNS	
			NO.	DAY	NO.	DAY	NO.	DAY	NO.	DAY
0010										
	CTH U	88	-	-	-	-	-	-	54	4,752
	7 MILE RD	-	-	-	-	-	-	-	44	3,872
	USH 45	-	-	-	-	-	-	-	23	2,024
	92ND ST	-	-	-	-	-	-	-	22	1,936
	60TH ST	-	-	-	-	-	-	-	11	968
	I 41	-	-	-	-	-	-	-	98	8,624
	STH 100	-	-	-	-	-	-	-	23	2,024
	8 MILE RD	-	-	-	-	-	-	-	11	968
	CTH G	-	-	-	-	-	-	-	63	5,544
	UNDISTRIBUTED	-	10	880	14	1,232	28	2,464	-	-
PROJECT TOTAL				880		1,232		2,464		30,712

**TRAFFIC CONTROL ITEMS**

CATEGORY	LOCATION	DURATION	643.0900		643.1050		COMMENTS
			TRAFFIC CONTROL SIGNS		TRAFFIC CONTROL SIGNS PCMS		
			NO.	DAY	NO.	DAY	
0010	CTH U	88	8	704			
	7 MILE RD	88	8	704			
	CTH U & 7 MILE ROAD	7			4	28	PRIOR TO CONSTRUCTION
PROJECT TOTAL				1,408		28	

**TRACKING PADS**

CATEGORY	LOCATION	628.7560
		EACH
0010	UNDISTRIBUTED	4
PROJECT TOTAL		4

**SAWING**

CATEGORY	LOCATION	STATION	TO	STATION	OFFSET	ALIGNMENT	690.0150
							SAWING ASPHALT LF
0010	CTH U NORTH LEG	-	-	267+38	RT & LT	NB	24
	CTH U SOUTH LEG	-	-	256+84	RT & LT	NB	24
	7 MILE RD EAST LEG	-	-	109+74	RT & LT	EB	24
	7 MILE RD WEST LEG	-	-	100+00	RT & LT	EB	24
SUBTOTAL							96

**TRAFFIC CONTROL COVERING SIGNS**

CATEGORY	NUMBER OF CYCLES	643.0910		643.0920	
		TRAFFIC CONTROL COVERING SIGNS TYPE I		TRAFFIC CONTROL COVERING SIGNS TYPE II	
		NO.	EACH	NO.	EACH
0010	1	4	4	4	4
SUBTOTAL			4		4

**BUTT JOINT**

CATEGORY	LOCATION	STATION	TO	STATION	ALIGNMENT	204.0115
						REMOVING ASPHALTIC SURFACE BUTT JOINTS SY
0010	7 MILE RD EAST LEG	95+64	-	96+00	EB	13
	7 MILE RD WEST LEG	111+49	-	111+83	EB	13
SUBTOTAL						26

**MOBILIZATION**

CATEGORY	LOCATION	619.1000
		MOBILIZATION EACH
0010	PROJECT	1
PROJECT TOTAL		1

**WATER**

CATEGORY	LOCATION	624.0100
		MGAL
0010	PROJECT-BASE COMPACTION	184
	DUST CONTROL	41
PROJECT TOTAL		225

PROJECT NO: 2816-03-70

HWY: CTH U

COUNTY: RACINE

MISCELLANEOUS QUANTITIES

SHEET

E

3

3

MAINTENANCE AND REPAIR OF HAUL ROADS (PROJECT)

618.0100 MAINTENANCE AND REPAIR OF HAUL ROADS (PROJECT)		
CATEGORY	LOCATION	EACH
0010	PROJECT	1
PROJECT TOTAL		1

CONSTRUCTION STAKING ITEMS

CATEGORY	LOCATION	STATION	TO	STATION	ALIGNMENT	650.4000	650.4500	650.5000	650.5500	650.6000	650.9911	650.9920	650.8501
						CONSTRUCTION STAKING STORM SEWER EACH	CONSTRUCTION STAKING SUBGRADE LF	CONSTRUCTION STAKING BASE LF	CONSTRUCTION STAKING CURB GUTTER AND GUTTER LF	CONSTRUCTION STAKING PIPE CULVERTS EACH	CONSTRUCTION STAKING SUPPLEMENTAL CONTROL (PROJECT) EACH	CONSTRUCTION STAKING SLOPE STAKES LF	CONSTRUCTION STAKING ELECTRICAL INSTALLATIONS (PROJECT) EACH
0010	CTH U SOUTH LEG	256+84	-	261+54	NB	3	470	470	276	2	-	470	-
	CENTER CIRCLE	1+00	-	3+85.88	CC	3	285	285	460	-	-	285	-
	CTH U NORTH LEG	262+82	-	267+29	NB	3	447	447	250	-	-	447	-
	7 MILE WEST LEG	100+00	-	104+26	EB	3	426	426	300	2	-	426	-
	7 MILE EAST LEG	105+62	-	109+74	EB	3	412	412	300	-	-	412	-
	SE QUAD	0+00	-	1+71	SE	-	-	-	180	-	-	-	-
	NE QUAD	0+00	-	1+93	NE	-	-	-	192	-	-	-	-
	NW QUAD	0+00	-	1+80	NW	-	-	-	180	-	-	-	-
	SW QUAD	0+00	-	1+81	SW	-	-	-	180	-	-	-	-
<u>CTH U &amp; 7 MILE RD</u>											1		1
SUBTOTAL						15	2,040	2,040	2,318	4	1	2,040	1

PROJECT NO: 2816-03-70

HWY: CTH U

COUNTY: RACINE

MISCELLANEOUS QUANTITIES

SHEET

E

# STATE OF WISCONSIN DEPARTMENT OF TRANSPORTATION TRANSPORTATION PROJECT PLAT TITLE SHEET

## 2816-03-70

### V RAYMOND CTH U

INTERSECTION WITH 7 MILE ROAD

### CTH U

### RACINE COUNTY



#### CONVENTIONAL SYMBOLS

SECTION LINE	---	SECTION CORNER SYMBOL		R/W MONUMENT (TO BE SET)	●
QUARTER LINE	---	SECTION CORNER MONUMENT		NON-MONUMENTED R/W POINT	○
SIXTEENTH LINE	---	GEODETIC SURVEY MONUMENT		FOUND IRON PIN (1-INCH UNLESS NOTED)	IP
NEW REFERENCE LINE	---	SIXTEENTH CORNER MONUMENT		OFF-PREMISE SIGN	
NEW R/W LINE	---	SIGN		COMPENSABLE	
EXISTING R/W OR HE LINE	---	ELECTRIC POLE		NON-COMPENSABLE	
PROPERTY LINE	---	TELEPHONE POLE			
LOT, TIE & OTHER MINOR LINES	---	PEDESTAL (LABEL TYPE) (TV, TEL, ELEC, ETC.)			
SLOPE INTERCEPT	---	ACCESS RESTRICTED BY ACQUISITION			
CORPORATE LIMITS	---	NO ACCESS (BY STATUTORY AUTHORITY)			
UNDERGROUND FACILITY (COMMUNICATIONS, ELECTRIC, ETC.)	---	ACCESS RESTRICTED (BY PREVIOUS PROJECT OR CONTROL)			
NEW R/W (FEE OR HE) (HATCHING VARIES BY OWNER)	---	NO ACCESS (NEW HIGHWAY)			
TEMPORARY LIMITED EASEMENT AREA	---	PARCEL NUMBER (25)		UTILITY NUMBER (40)	
EASEMENT AREA (PERMANENT LIMITED OR RESTRICTED DEVELOPMENT)	---	PARALLEL OFFSETS			
TRANSMISSION STRUCTURES	---				
BUILDING TO BE REMOVED					
BRIDGE					
CULVERT					

#### CONVENTIONAL ABBREVIATIONS

ACCESS RIGHTS	AR	POINT OF COMPOUND CURVE	PCC
ACRES	AC	POINT OF INTERSECTION	PI
AHEAD	AH	PROPERTY LINE	PL
ALUMINUM	ALUM	RECORDED AS (100')	
AND OTHERS	ET AL	REEL / IMAGE	R/I
BACK	BK	REFERENCE LINE	R/L
BLOCK	BLK	REMAINING	REM
CENTERLINE	C/L	RESTRICTIVE DEVELOPMENT	RDE
CERTIFIED SURVEY MAP	CSM	EASEMENT	
CONCRETE	CONC	RIGHT	RT
COUNTY	CO	RIGHT OF WAY	R/W
COUNTY TRUNK HIGHWAY	CTH	SECTION	SEC
DISTANCE	DIST	SEPTIC VENT	SEPV
CORNER	COR	SQUARE FEET	SF
DOCUMENT NUMBER	DOC	STATE TRUNK HIGHWAY	STH
EASEMENT	EASE	STATION	STA
EXISTING	EX	TELEPHONE PEDESTAL	TP
GAS VALVE	GV	TEMPORARY LIMITED EASEMENT	TLE
GRID NORTH	GN		
HIGHWAY EASEMENT	HE	TRANSPORTATION PROJECT PLAT	TPP
IDENTIFICATION	ID	UNITED STATES HIGHWAY	USH
LAND CONTRACT	LC	VOLUME	V
LEFT	LT		
MONUMENT	MON		
NATIONAL GEODETIC SURVEY	NGS		
NUMBER	NO		
OUTLOT	OL		
PAGE	P		
POINT OF TANGENCY	PT		
PERMANENT LIMITED EASEMENT	PLE		
POINT OF BEGINNING	POB		
POINT OF CURVATURE	PC		

#### CURVE DATA ABBREVIATIONS

LONG CHORD	LCH
LONG CHORD BEARING	LCB
RADIUS	R
DEGREE OF CURVE	D
CENTRAL ANGLE	Δ / DELTA
LENGTH OF CURVE	L
TANGENT	T
DIRECTION AHEAD	DA
DIRECTION BACK	DB

#### CONVENTIONAL UTILITY SYMBOLS

WATER	---
GAS	---
TELEPHONE	---
OVERHEAD TRANSMISSION LINES	---
ELECTRIC	---
CABLE TELEVISION	---
FIBER OPTIC	---
SANITARY SEWER	---
STORM SEWER	---
ELECTRIC TOWER	⊠

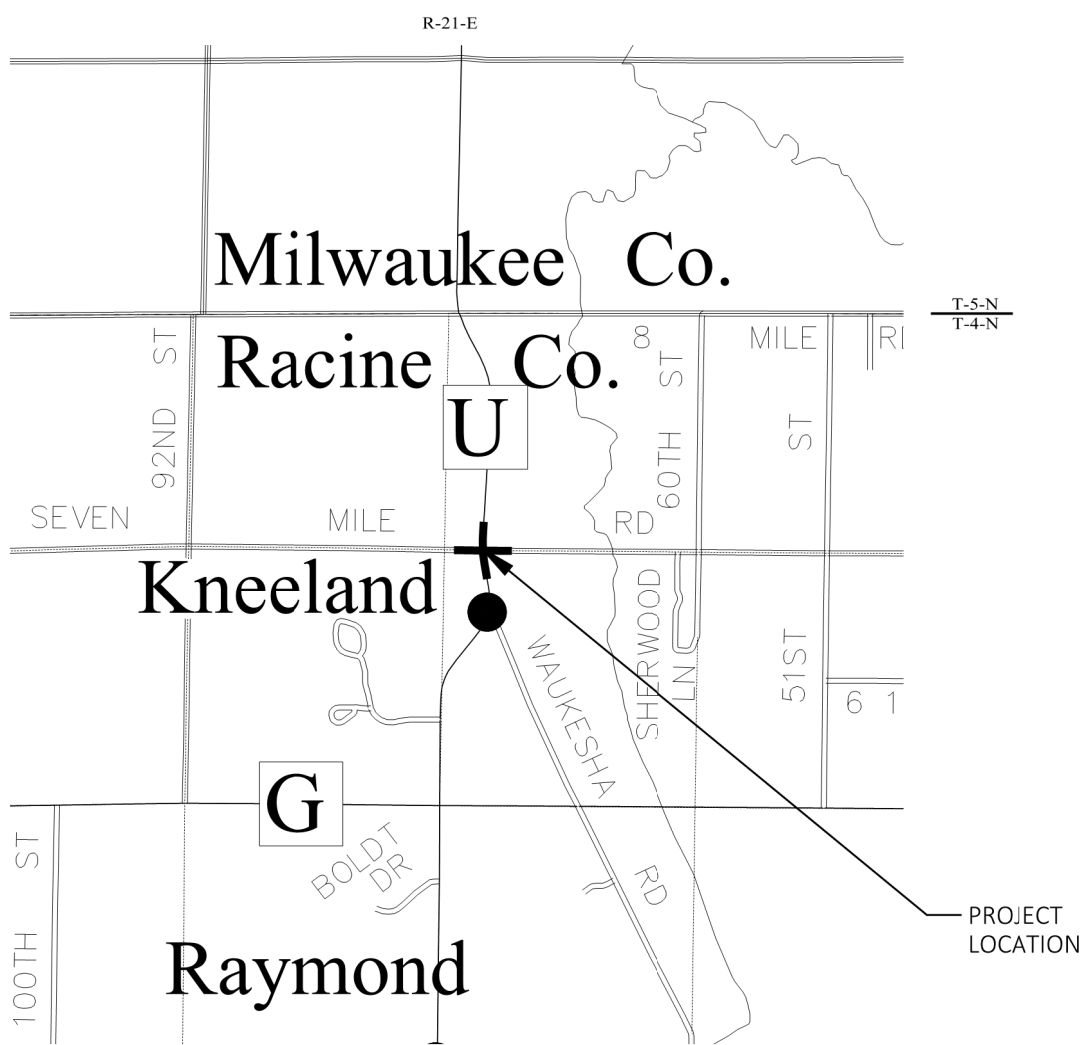

THE NOTES, CONVENTIONAL SIGNS, AND ABBREVIATIONS ARE ASSOCIATED WITH EACH TRANSPORTATION PROJECT PLAT FOR PROJECT 2816-03-70

#### NOTES:

POSITIONS SHOWN ON THIS PLAT ARE WISCONSIN COORDINATE REFERENCE SYSTEM COORDINATES (WISCRS), RACINE COUNTY, NAD83(2012), IN U.S. SURVEY FEET. VALUES ARE GRID COORDINATES, GRID BEARINGS, AND GRID DISTANCES. GRID DISTANCES MAY BE USED AS GROUND DISTANCES.

ALL NEW RIGHT-OF-WAY MONUMENTS WILL BE TYPE 2 (TYPICALLY 3/4" X 24" IRON REBARS), UNLESS OTHERWISE NOTED, AND WILL BE PLACED PRIOR TO THE COMPLETION OF THE PROJECT.

ALL RIGHT-OF-WAY LINES DEPICTED IN THE NON-ACQUISITION AREAS ARE INTENDED TO RE-ESTABLISH EXISTING RIGHT-OF-WAY LINES AS DETERMINED FROM PREVIOUS PROJECTS, OTHER RECORDED DOCUMENTS, OR FROM CENTERLINE OF EXISTING PAVEMENTS.

RIGHT-OF-WAY BOUNDARIES ARE DEFINED WITH COURSES OF THE PERIMETER OF THE HIGHWAY LANDS REFERENCED TO THE U.S. PUBLIC LAND SURVEY SYSTEM OR OTHER "SURVEYS" OF PUBLIC RECORD.

DIMENSIONING FOR THE NEW RIGHT-OF-WAY IS MEASURED ALONG AND PERPENDICULAR TO THE NEW REFERENCE LINES.

A TEMPORARY LIMITED EASEMENT (TLE) IS A RIGHT FOR CONSTRUCTION PURPOSES, AS DEFINED HEREIN, INCLUDING THE RIGHT TO OPERATE NECESSARY EQUIPMENT THEREON, THE RIGHT OF INGRESS AND EGRESS, AS LONG AS REQUIRED FOR SUCH PUBLIC PURPOSE, INCLUDING THE RIGHT TO PRESERVE, PROTECT, REMOVE, OR PLANT THEREON ANY VEGETATION THAT THE HIGHWAY AUTHORITIES MAY DEEM DESIRABLE. ALL (TLEs) ON THIS PLAT EXPIRE AT THE COMPLETION OF THE CONSTRUCTION PROJECT FOR WHICH THIS INSTRUMENT IS GIVEN.

PROPERTY LINES SHOWN ON THIS PLAT ARE DRAWN FROM DATA DERIVED FROM MAPS AND DOCUMENTS OF PUBLIC RECORD AND/OR EXISTING OCCUPATIONAL LINES. THIS PLAT MAY NOT BE A TRUE REPRESENTATION OF EXISTING PROPERTY LINES, EXCLUDING RIGHT-OF-WAY, AND SHOULD NOT BE USED AS A SUBSTITUTE FOR AN ACCURATE FIELD SURVEY.

FOR THE CURRENT ACCESS/DRIVEWAY INFORMATION, CONTACT THE RACINE COUNTY HIGHWAY DEPARTMENT.

PARCEL AND UTILITY IDENTIFICATION NUMBERS MAY NOT POINT TO ALL AREAS OF ACQUISITION, AS NOTED ON THE TPP DETAIL PAGES.

INFORMATION FOR THE BASIS OF EXISTING HIGHWAY RIGHT-OF-WAY POINTS OF REFERENCE AND ACCESS CONTROL ARE LISTED ON THE TPP DETAIL PAGES.

LAYOUT  
SCALE 0 2000 FT.

PROJECT NUMBER 2816-03-20 -4.01  
SHEET 2 OF 2  
AMENDMENT NO:

**TRANSPORTATION PROJECT PLAT NO: 2816-03-70-4.01**

THAT PART OF LOTS 3, 4 AND 5 OF SPLINTER FARMS PLAT LOCATED IN PART OF THE NW1/4 OF THE NW1/4 OF SECTION 10, TOWNSHIP 4 NORTH, RANGE 21 EAST, AND LANDS IN PART OF SW1/4 OF THE SW 1/4 OF SECTION 3, TOWNSHIP 4 NORTH, RANGE 21 EAST, VILLAGE OF RAYMOND, RACINE COUNTY, WISCONSIN.

RELOCATION ORDER - V RAYMOND CTH U, INTERSECTION WITH 7 MILE ROAD, CTH U, RACINE COUNTY

TO PROPERLY ESTABLISH, LAYOUT, WIDEN, ENLARGE, EXTEND, CONSTRUCT, RECONSTRUCT, IMPROVE, OR MAINTAIN A PORTION OF THE HIGHWAY DESIGNATED ABOVE, RACINE COUNTY DEEMS IT NECESSARY TO RELOCATE OR CHANGE SAID HIGHWAY AND ACQUIRE CERTAIN LANDS AND INTERESTS OR RIGHTS IN LANDS FOR THE ABOVE PROJECT.

TO EFFECT THIS CHANGE, PURSUANT TO AUTHORITY GRANTED UNDER SECTION 83.08 (1), WISCONSIN STATUTES, RACINE COUNTY HEREBY ORDERS THAT:

- THAT PORTION OF SAID HIGHWAY AS SHOWN ON THIS PLAT IS LAID OUT AND ESTABLISHED TO THE LINES AND WIDTHS AS SO SHOWN FOR THE ABOVE PROJECT
- THE LANDS OR INTERESTS OR RIGHTS IN LANDS AS SHOWN ON THIS PLAT ARE REQUIRED BY RACINE COUNTY FOR THE ABOVE PROJECT AND SHALL BE ACQUIRED IN THE NAME OF RACINE COUNTY, PURSUANT TO THE PROVISIONS OF SECTION 83.08 (1), WISCONSIN STATUTES.

**NOTES:**

POSITIONS SHOWN ON THIS PLAT ARE WISCONSIN COORDINATE REFERENCE SYSTEM COORDINATES (WISCRS), RACINE COUNTY, NAD83 (2011) IN US SURVEY FEET. VALUES SHOWN ARE GRID COORDINATES, GRID BEARINGS, AND GRID DISTANCES. GRID DISTANCES MAY BE USED AS GROUND DISTANCES.

ALL NEW RIGHT-OF-WAY MONUMENTS WILL BE TYPE 2 (TYPICALLY 3/4"x24" IRON REBARS) UNLESS OTHERWISE NOTED, AND WILL BE PLACED PRIOR TO THE COMPLETION OF THE PROJECT.

FOR THE LATEST ACCESS/DRIVEWAY INFORMATION, CONTACT THE RACINE COUNTY HIGHWAY DEPARTMENT.

EXISTING ACCESS CONTROL ALONG CTH U HAS BEEN ESTABLISHED FROM SPLINTER FARMS PLAT.

EXISTING HIGHWAY RIGHT-OF-WAY SHOWN HEREIN IS BASED ON THE FOLLOWING POINTS OF REFERENCE FOR CTH U AND 7 MILE ROAD: RIGHT-OF-WAY PLAT S 0344 (8), SPLINTER FARMS PLAT, PLATS OF SURVEY, 6658, 5569, 829673 AND EXISTING CENTERLINE.

FOR ADDITIONAL INFORMATION REFER TO TITLE SHEET, RECORDED AS SHEET 2 OF 2.

POINT NO.	STATION	OFFSET
TLE1500	103+54.00	-44.00'
TLE1501	103+54.00	-49.00'
TLE1502	264+12.00'U	-50.28'
TLE1503	264+12.00'U	-60.28'
TLE1504	265+98.00'U	-60.00'
TLE1505	265+98.00'U	-50.00'
TLE1506	266+38.00'U	45.00'
TLE1507	265+38.00'U	62.50'
TLE1508	263+13.00'U	76.00'
TLE1509	108+87.00	-64.75'
TLE1510	110+03.74	-64.75'
TLE1511	112+32.00	-50.50'
TLE1512	112+70.00	51.00'
TLE1513	110+04.00	51.00'
TLE1514	108+81.55	70.00'
TLE1515	261+04.83'U	45.12'
TLE1516	259+72.00'U	48.00'
TLE1517	257+49.50'U	65.00'
TLE1518	257+49.50'U	70.00'
TLE1519	256+81.00'U	70.00'
TLE1520	256+81.00'U	-65.00'
TLE1521	259+58.00'U	-63.68'
TLE1522	260+81.00'U	-73.50'
TLE1523	260+81.00'U	-79.00'
TLE1524	261+15.03'U	-78.50'
TLE1525	106+83.37	60.00'
TLE1526	103+88.00	60.00'
TLE1527	103+88.00	47.00'
TLE1528	103+88.00	47.00'
TLE1529	103+14.00	33.00'
TLE1530	103+14.00	33.00'

**CURVE 1**  
 PI STA = 262+22.47 'U'  
 Y = 223586.149  
 X = 579292.076  
 DELTA = 13°22'03" RT  
 D = 2°59'59"  
 T = 223.82'  
 L = 445.61'  
 R = 1910.00'  
 PC STA = 259+98.64 'U'  
 PT STA = 264+44.26 'U'  
 DB = S09°51'59"E  
 DA = N03°30'03"E

EXISTING MONUMENTS			
POINT	Y (NORTHING)	X (EASTING)	DESCRIPTION
IP710	224000.154	579363.544	IRON SPIKE FOUND
IP721	223547.351	578887.526	3/4" IRON ROD FOUND
IP722	223473.872	579265.991	1" IRON ROD FOUND
IP723	223544.415	579183.220	1" IRON ROD FOUND
IP724	223358.767	579285.996	1" IRON ROD FOUND
IP725	223357.851	579280.906	1" IRON ROD FOUND
IP739	223275.665	579391.798	3/4" IRON ROD FOUND
IP740	223472.971	579357.358	3/4" IRON ROD FOUND
IP741	223542.007	579416.147	3/4" IRON ROD FOUND
IP742	223538.066	579789.038	3/4" IRON ROD FOUND
IP743	223593.678	579734.686	1" IRON ROD FOUND
IP744	223594.444	579841.087	1" IRON ROD FOUND

Document # **2659043**  
 RACINE COUNTY REGISTER OF DEEDS  
 July 27, 2023 8:37 AM  
*Karin J. Pope*  
 KARIE POPE  
 RACINE COUNTY  
 REGISTER OF DEEDS  
 Fee Amount: \$25.00  
 Pages: 2

RESERVED FOR REGISTER OF DEEDS  
 PROJECT NUMBER 2618-03-70-4.01  
 SHEET 1 OF 2  
 AMENDMENT NO: \_\_\_\_\_

**SCHEDULE OF LANDS & INTERESTS REQUIRED**

OWNER'S NAMES ARE SHOWN FOR REFERENCE PURPOSES ONLY AND ARE SUBJECT TO CHANGE PRIOR TO THE TRANSFER OF LAND INTERESTS TO THE COUNTY OF RACINE.

PARCEL NUMBER	OWNERS	INTERESTS REQUIRED	R/W SF REQUIRED			TLE SF
			NEW	EXISTING	TOTAL	
1	DAVID D'ANGELO	TLE	---	---	---	974
2	TERRA JANE MORGAN AND LAURA LEE MORGAN	FEE/TLE	11981	---	11981	3608
3	SANDRA L. VOLLMER AND LONNIE B. BROOKS	FEE/TLE	5799	---	5799	3034
4	ROBERT R. REBERNICK, DEBTOR IN POSSESSION UNDER CASE NO. 19-26000-BEH, PENDING IN THE US BANKRUPTCY COURT FOR THE EASTERN DISTRICT OF WISCONSIN	FEE/TLE	8879	---	8879	6703
6	NICHOLAS W. WILKKOMM AND CATHERINE E. WILKKOMM	FEE/TLE	6426	---	6426	3339

4

4

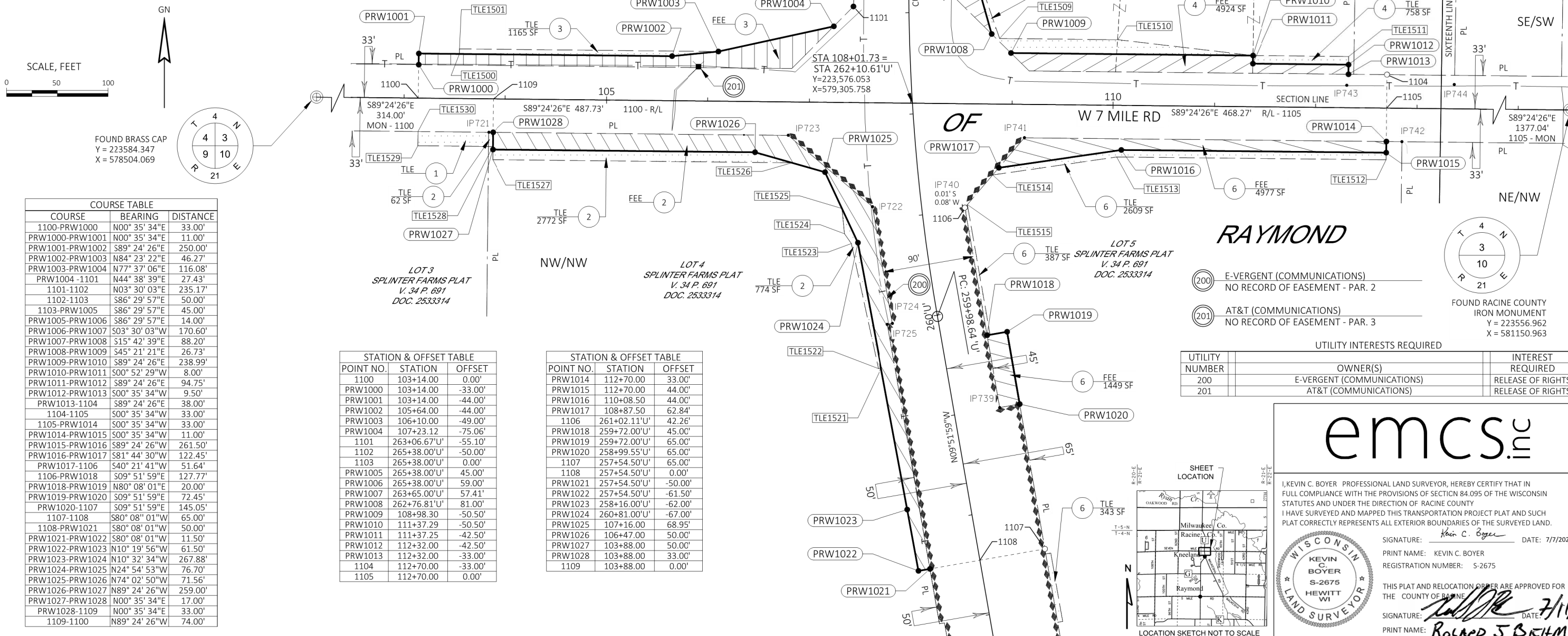

COURSE	BEARING	DISTANCE
1100-PRW1000	N00° 35' 34"E	33.00'
PRW1000-PRW1001	N00° 35' 34"E	11.00'
PRW1001-PRW1002	S89° 24' 26"E	250.00'
PRW1002-PRW1003	N84° 23' 22"E	46.27'
PRW1003-PRW1004	N77° 37' 06"E	116.08'
PRW1004-1101	N44° 38' 39"E	27.43'
1101-1102	N03° 30' 03"E	235.17'
1102-1103	S86° 29' 57"E	50.00'
1103-PRW1005	S86° 29' 57"E	45.00'
PRW1005-PRW1006	S86° 29' 57"E	14.00'
PRW1006-PRW1007	S03° 30' 03"W	170.60'
PRW1007-PRW1008	S15° 42' 39"E	88.20'
PRW1008-PRW1009	S45° 21' 21"E	26.73'
PRW1009-PRW1010	S89° 24' 26"E	238.99'
PRW1010-PRW1011	S00° 52' 29"W	8.00'
PRW1011-PRW1012	S89° 24' 26"E	94.75'
PRW1012-PRW1013	S00° 35' 34"W	9.50'
PRW1013-1104	S89° 24' 26"E	38.00'
1104-1105	S00° 35' 34"W	33.00'
1105-PRW1014	S00° 35' 34"W	33.00'
PRW1014-PRW1015	S00° 35' 34"W	11.00'
PRW1015-PRW1016	S89° 24' 26"W	261.50'
PRW1016-PRW1017	S81° 44' 30"W	122.45'
PRW1017-1106	S40° 21' 41"W	51.64'
1106-PRW1018	S09° 51' 59"E	127.77'
PRW1018-PRW1019	N80° 08' 01"E	20.00'
PRW1019-PRW1020	S09° 51' 59"E	72.45'
PRW1020-1107	S09° 51' 59"E	145.05'
1107-1108	S80° 08' 01"W	65.00'
1108-PRW1021	S80° 08' 01"W	50.00'
PRW1021-PRW1022	S80° 08' 01"W	11.50'
PRW1022-PRW1023	N10° 19' 56"W	61.50'
PRW1023-PRW1024	N10° 32' 34"W	267.88'
PRW1024-PRW1025	N24° 54' 53"W	76.70'
PRW1025-PRW1026	N74° 02' 50"W	71.56'
PRW1026-PRW1027	N89° 24' 26"W	259.00'
PRW1027-PRW1028	N00° 35' 34"E	17.00'
PRW1028-1109	N00° 35' 34"E	33.00'
1109-1100	N89° 24' 26"W	74.00'

POINT NO.	STATION	OFFSET
1100	103+14.00	0.00'
PRW1000	103+14.00	-33.00'
PRW1001	103+14.00	-44.00'
PRW1002	105+64.00	-44.00'
PRW1003	106+10.00	-49.00'
PRW1004	107+23.12	-75.06'
1101	263+06.67'U	-55.10'
1102	265+38.00'U	-50.00'
1103	265+38.00'U	0.00'
PRW1005	265+38.00'U	45.00'
PRW1006	265+38.00'U	59.00'
PRW1007	263+65.00'U	57.41'
PRW1008	262+76.81'U	81.00'
PRW1009	108+98.30	-50.50'
PRW1010	111+37.29	-50.50'
PRW1011	111+37.25	-42.50'
PRW1012	112+32.00	-42.50'
PRW1013	112+32.00	-33.00'
1104	112+70.00	-33.00'
1105	112+70.00	0.00'

POINT NO.	STATION	OFFSET
PRW1014	112+70.00	33.00'
PRW1015	112+70.00	44.00'
PRW1016	110+08.50	44.00'
PRW1017	108+87.50	62.84'
1106	261+02.11'U	42.26'
PRW1018	259+72.00'U	45.00'
PRW1019	259+72.00'U	65.00'
PRW1020	258+99.55'U	65.00'
1107	257+54.50'U	65.00'
1108	257+54.50'U	0.00'
PRW1021	257+54.50'U	-50.00'
PRW1022	257+54.50'U	-61.50'
PRW1023	258+16.00'U	-62.00'
PRW1024	260+81.00'U	-67.00'
PRW1025	107+16.00	68.95'
PRW1026	106+47.00	50.00'
PRW1027	103+88.00	50.00'
PRW1028	103+88.00	33.00'
1109	103+88.00	0.00'

- (200) E-VERGENT (COMMUNICATIONS)  
NO RECORD OF EASEMENT - PAR. 2
- (201) AT&T (COMMUNICATIONS)  
NO RECORD OF EASEMENT - PAR. 3

UTILITY NUMBER	OWNER(S)	INTEREST REQUIRED
200	E-VERGENT (COMMUNICATIONS)	RELEASE OF RIGHTS
201	AT&T (COMMUNICATIONS)	RELEASE OF RIGHTS

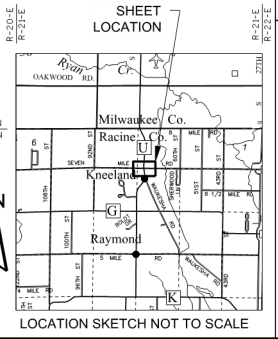

**emcs**  
 KEVIN C. BOYER  
 RACINE COUNTY  
 LAND SURVEYOR  
 S-2675  
 HEWITT WI

I, KEVIN C. BOYER, PROFESSIONAL LAND SURVEYOR, HEREBY CERTIFY THAT IN FULL COMPLIANCE WITH THE PROVISIONS OF SECTION 84.095 OF THE WISCONSIN STATUTES AND UNDER THE DIRECTION OF RACINE COUNTY I HAVE SURVEYED AND MAPPED THIS TRANSPORTATION PROJECT PLAT AND SUCH PLAT CORRECTLY REPRESENTS ALL EXTERIOR BOUNDARIES OF THE SURVEYED LAND.  
 SIGNATURE: *Kevin C. Boyer* DATE: 7/7/2023  
 PRINT NAME: KEVIN C. BOYER  
 REGISTRATION NUMBER: S-2675  
 THIS PLAT AND RELOCATION ORDER ARE APPROVED FOR THE COUNTY OF RACINE  
 SIGNATURE: *Roland J. Berkham* DATE: 7/11/23  
 PRINT NAME: ROLAND J. BERKHAM



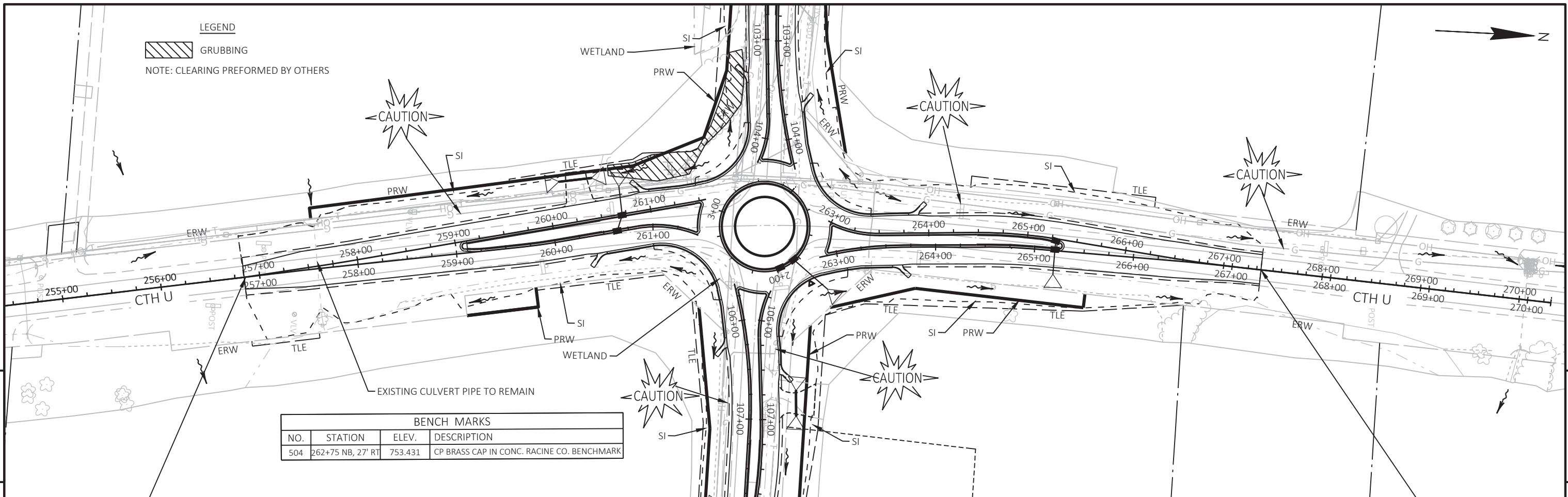

BEGIN PROJECT  
 STA 256+84.42

END PROJECT  
 STA 267+29.30

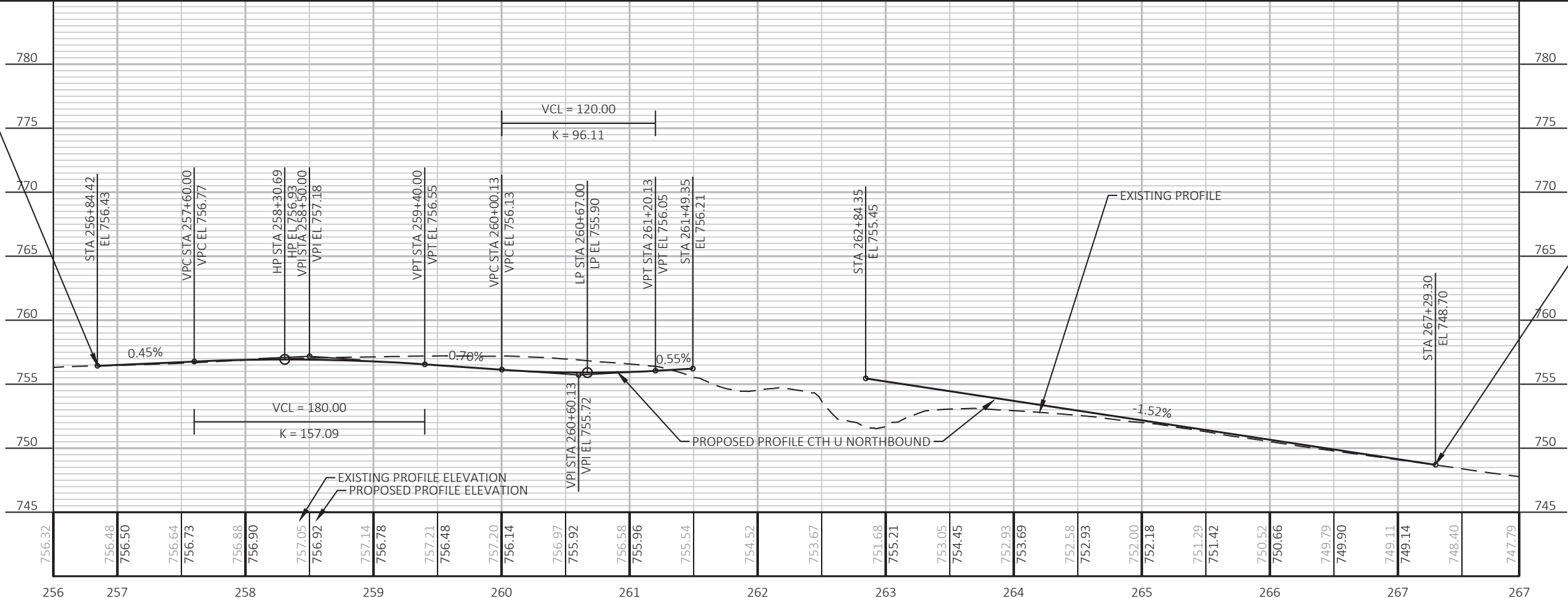

PROJECT NO: 2816-03-70      HWY: CTH U      COUNTY: RACINE      PLAN AND PROFILE: CTH U NB      SHEET: E

LEGEND

 GRUBBING

NOTE: CLEARING PERFORMED BY OTHERS

REMOVE EXISTING 15" CMCP  
12" CPRC REQUIRED

DRAINTILE EXPLORATION REQUIRED;  
DISCHARGE DRAINTILE TO DITCH



BENCH MARKS			
NO.	STATION	ELEV.	DESCRIPTION
504	262+75 NB, 27' RT	753.431	CP BRASS CAP IN CONC. RACINE CO. BENCHMARK

5

5

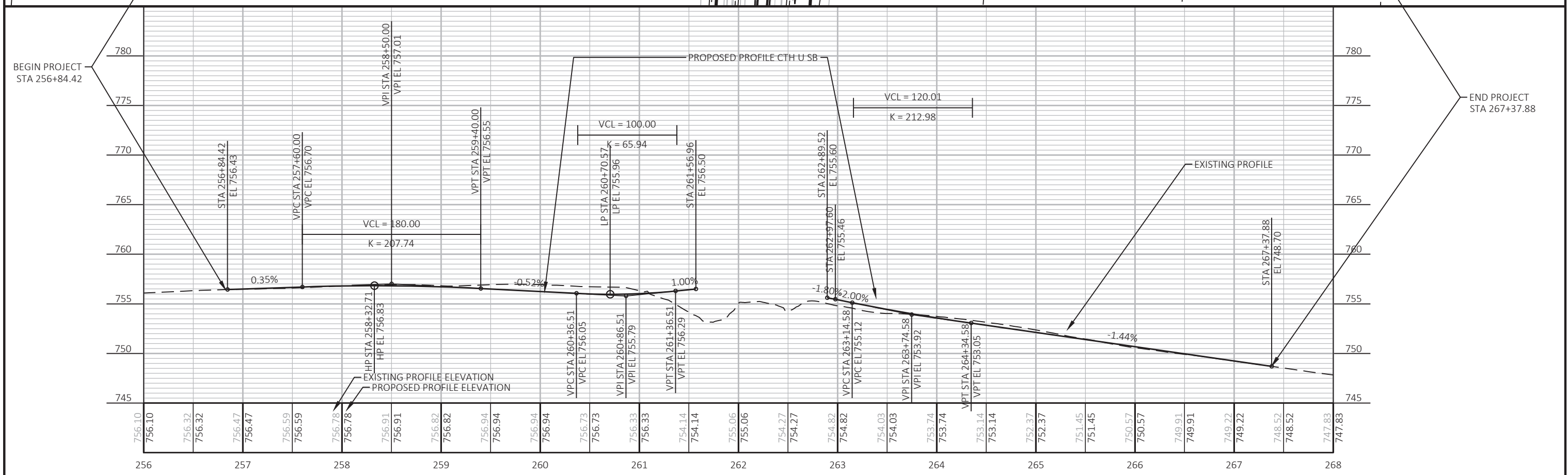

PROJECT NO: 2816-03-70	HWY: CTH U	COUNTY: RACINE	PLAN AND PROFILE: CTH U SB	SHEET E
------------------------	------------	----------------	----------------------------	---------



LEGEND

 GRUBBING  
NOTE: CLEARING PREFORMED BY OTHERS

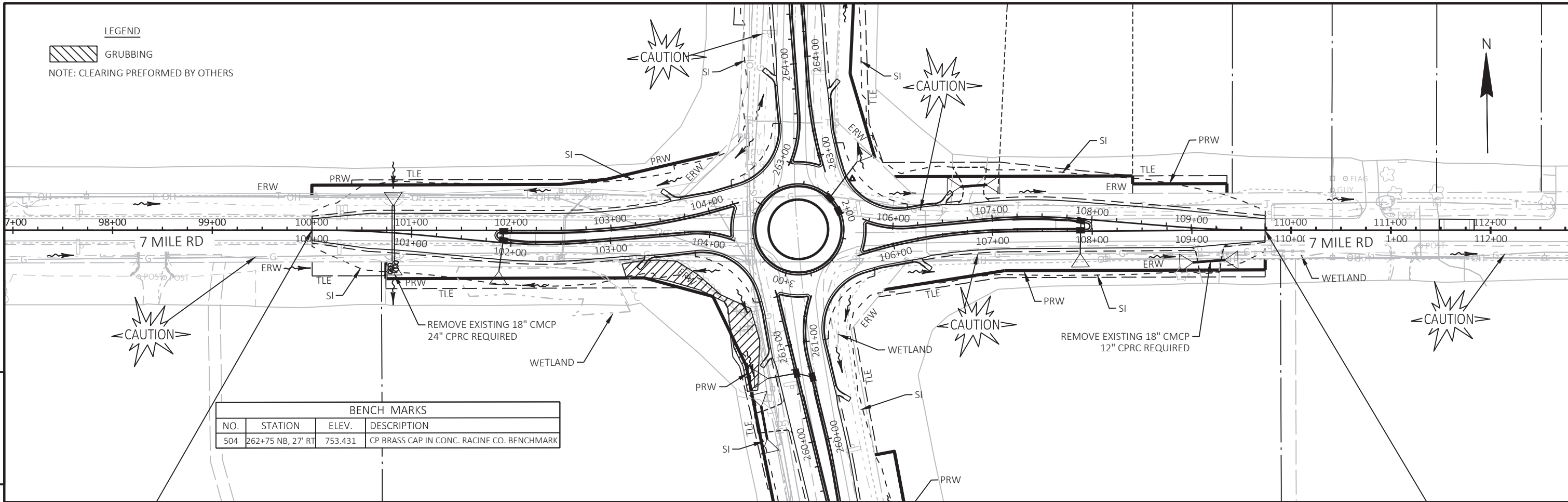

BENCH MARKS			
NO.	STATION	ELEV.	DESCRIPTION
504	262+75 NB, 27' RT	753.431	CP BRASS CAP IN CONC. RACINE CO. BENCHMARK

BEGIN CONSTRUCTION  
STA 100+00.00

END CONSTRUCTION  
STA 109+73.46

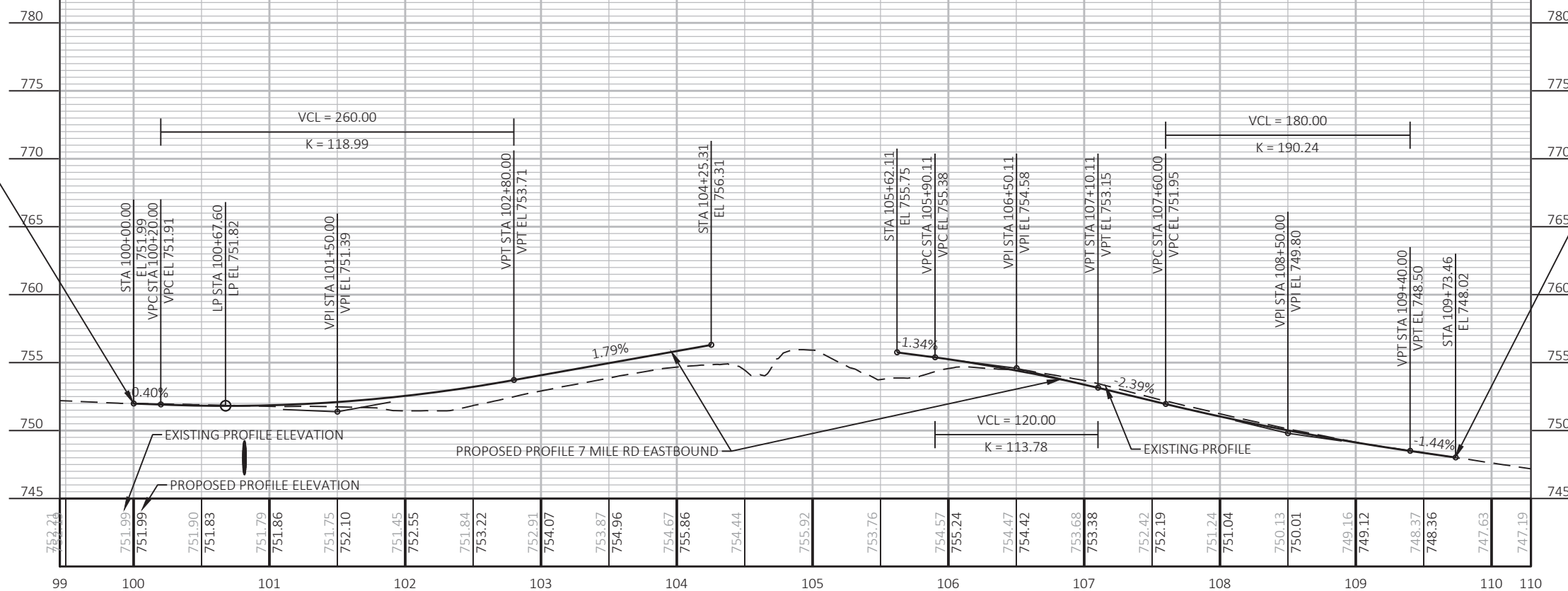

PROJECT NO: 2816-03-70

HWY: CTH U

COUNTY: RACINE

PLAN AND PROFILE: 7 MILE RD EB

SHEET

E

**LEGEND**  
 GRUBBING  
 NOTE: CLEARING PREFORMED BY OTHERS

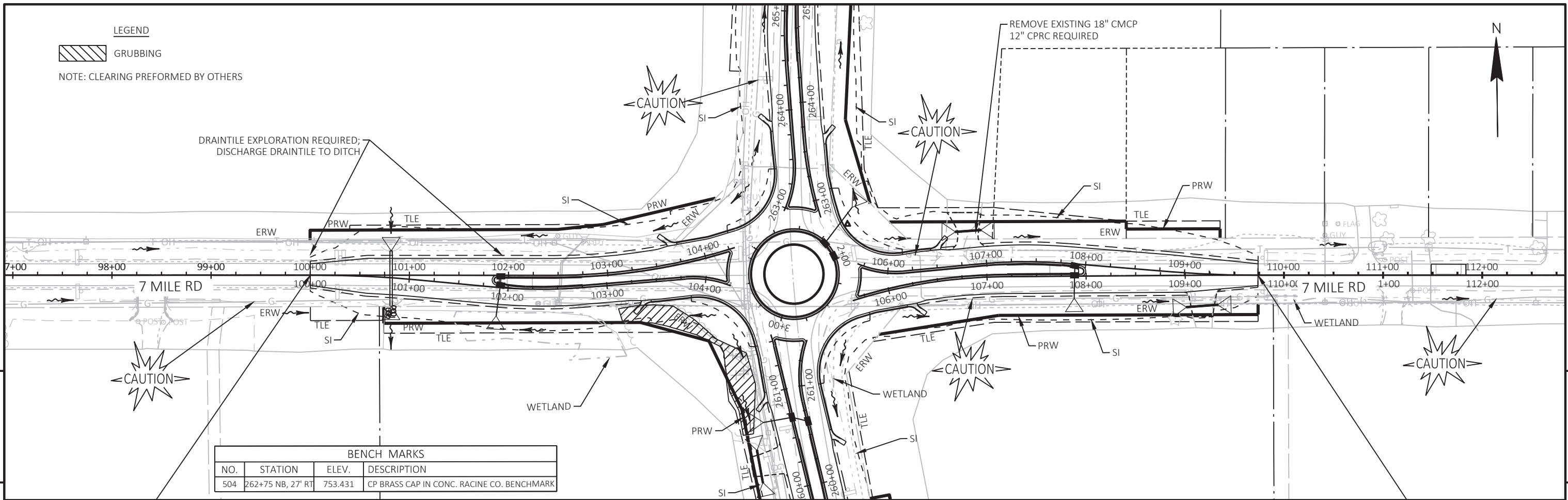

BENCH MARKS			
NO.	STATION	ELEV.	DESCRIPTION
504	262+75 NB, 27' RT	753.431	CP BRASS CAP IN CONC. RACINE CO. BENCHMARK

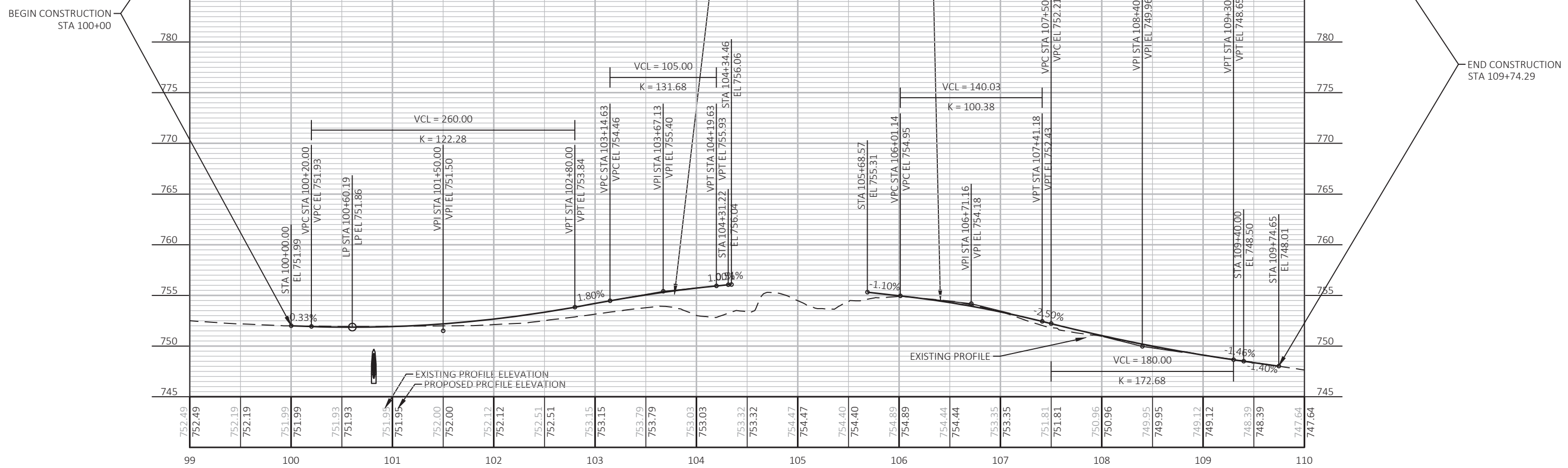

PROJECT NO: 2816-03-70      HWY: CTH U      COUNTY: RACINE      PLAN AND PROFILE: 7 MILE RD WB      SHEET: E

LEGEND  
 GRUBBING  
 NOTE: CLEARING PERFORMED BY OTHERS

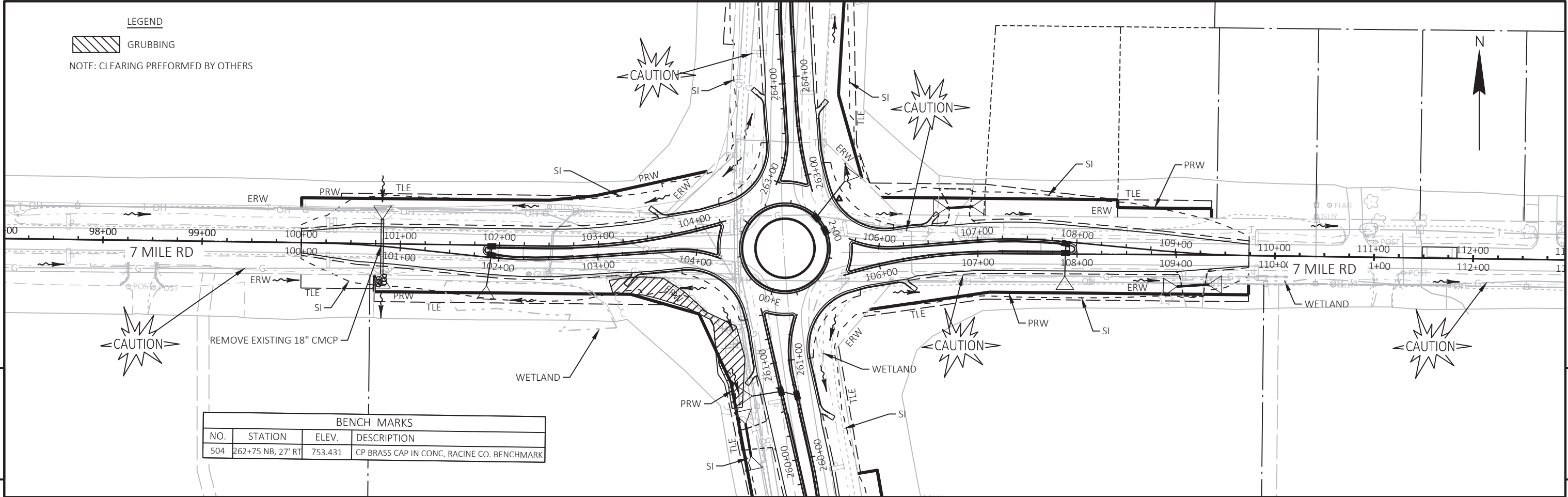

BENCH MARKS			
NO.	STATION	ELEV.	DESCRIPTION
504	262+75 NB, 27' RT	753.431	CP BRASS CAP IN CONC. RACINE CO. BENCHMARK

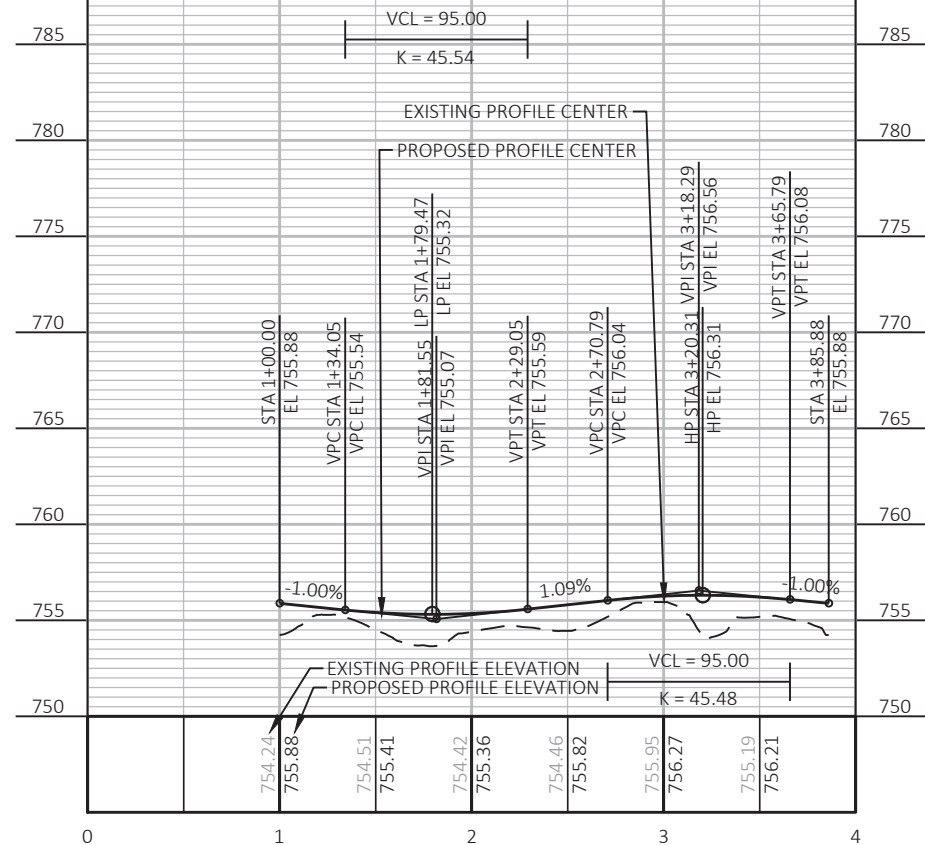

## Standard Detail Drawing List

08A05-20A	INLET COVERS TYPE A, H, A-S, H-S & Z
08A05-20C	INLET COVERS TYPE F, HM, HM-S, S, T, V, HM-GJ, & HM-GJ-S
08C07-02	INLETS 2X2-FT, 2X2.5-FT, 2X3-FT AND 2.5X3-FT
08D01-23A	CONCRETE CURB & GUTTER
08D01-23B	CONCRETE CURB, TIES AND CURB AND GUTTER APPLICATIONS
08D04-07	CONCRETE SURFACE DRAINS & ASPHALTIC FLUMES
08D21-01	DRIVEWAYS WITHOUT CURB & GUTTER
08E08-03	TYPICAL INSTALLATIONS OF EROSION BALES / TEMPORARY DITCH CHECKS
08E09-06	SILT FENCE
08E10-02	INLET PROTECTION TYPE A, B, C AND D
08E14-01	TRACKING PAD
08E15-01	CULVERT PIPE CHECK
08F01-11	APRON ENDWALLS FOR CULVERT PIPE
09B02-10	CONDUIT
09B04-12	PULL BOX
09C02-09	CONCRETE BASES, TYPES 1, 2, 5, & 6
09C03-04	TRANSFORMER/PEDESTAL BASES
09C14-03	CONCRETE CONTROL CABINET BASE, TYPE L
09D01-05	CABINET SERVICE INSTALLATION (METER BREAKER PEDESTAL)
09D04-03	LIGHTING CONTROL CABINET 120/240 VOLT
09E01-15D	POLE MOUNTINGS FOR LIGHTING UNITS, TYPE 5 (30 FEET)
09E03-06	NON-FREEWAY LIGHTING UNIT POLE WIRING
11B02-02	CONCRETE MEDIAN NOSE
13C19-03	HMA LONGITUDINAL JOINTS
14B29-01	SAFETY EDGE
15A03-02A	FLEXIBLE MARKER POST FOR CULVERT END
15A03-02B	FLEXIBLE MARKER POST FOR CULVERT END
15C02-09A	BARRICADES AND SIGNS FOR MAINLINE CLOSURES
15C02-09C	DETOUR SIGNING FOR MAINLINE CLOSURES
15C08-23A	PERMANENT LONGITUDINAL PAVEMENT MARKINGS
15C11-10B	CHANNELIZING DEVICES DRUMS, CONES, BARRICADES AND VERTICAL PANELS
15C18-08A	MEDIAN ISLAND MARKING PAVEMENT MARKINGS
15C18-08B	MEDIAN ISLAND MARKING MEDIAN ISLAND NOSE

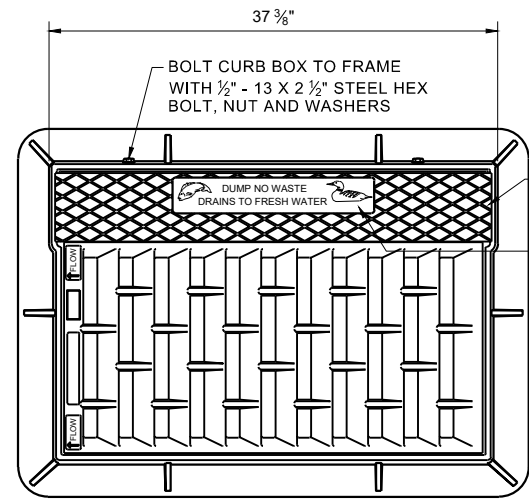

NOTE: EITHER CASTING IS ACCEPTABLE

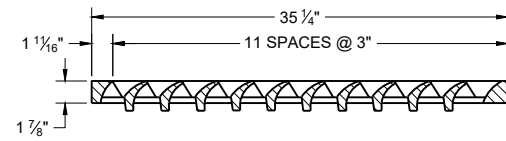
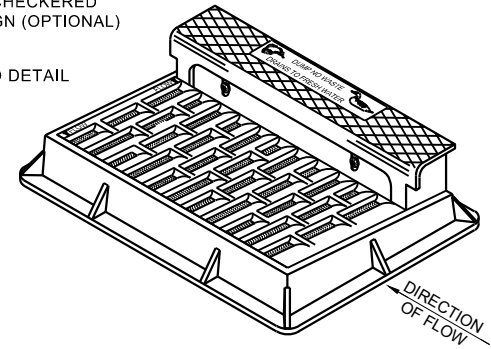

NOTE: CURB BOX HEIGHT ADJUSTABLE 6" - 9"

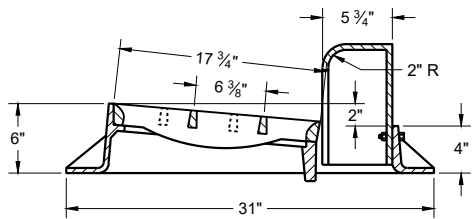
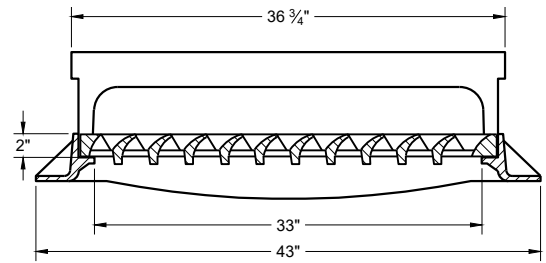
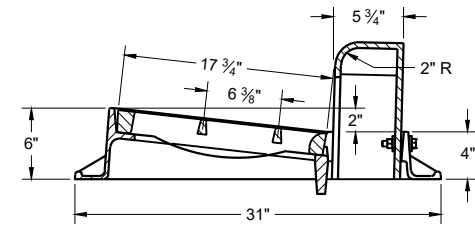
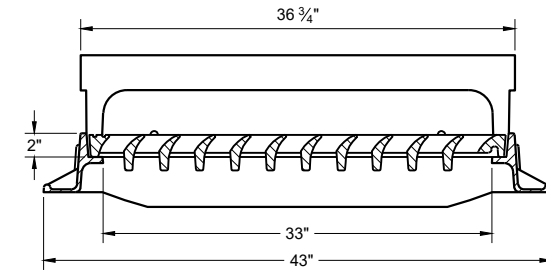

**TYPE "H"**

NOTE: EITHER CASTING IS ACCEPTABLE

1 1/8" DIAGONAL BARS WITH 1 5/8" OPENINGS

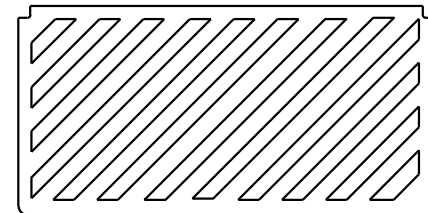

**SPECIAL GRATE FOR TYPE "H" COVER**

(MEASURES 35" X 17 3/4" X 2")  
(NOTED AS TYPE H-S ON DRAINAGE TABLE)

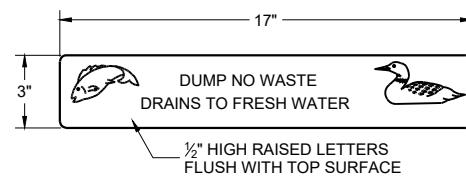

**LOGO DETAIL**

**GENERAL NOTES**

DETAILS OF CONSTRUCTION, MATERIALS AND WORKMANSHIP NOT SHOWN ON THIS DRAWING SHALL CONFORM TO THE PERTINENT REQUIREMENTS OF THE STANDARD SPECIFICATIONS AND THE APPLICABLE SPECIAL PROVISIONS.

DETAIL DRAWINGS FOR PROPOSED ALTERNATE DESIGNS FOR CATCH BASIN, MANHOLE AND INLET COVERS SHALL BE SUBMITTED TO THE ENGINEER FOR APPROVAL PROVIDING THAT SUCH ALTERNATE DESIGNS MAKE PROVISION FOR EQUIVALENT CAPACITY AND STRENGTH.

ROUND FRAMES AND COVERS SHALL HAVE CONTINUOUSLY MACHINED BEARING SURFACES TO PREVENT ROCKING AND RATTLING.

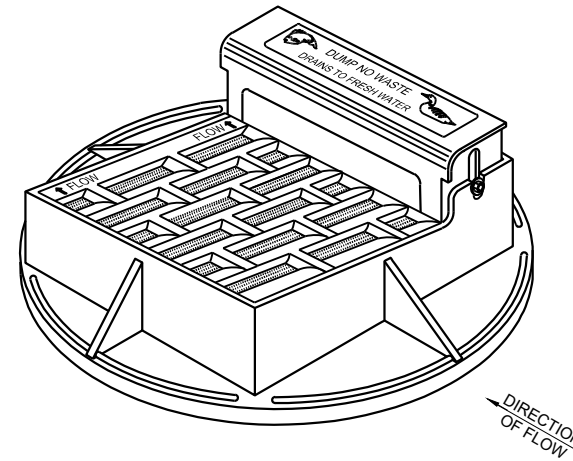

NOTE: CURB BOX HEIGHT ADJUSTABLE 6" - 9"

NOTE: EITHER CASTING IS ACCEPTABLE

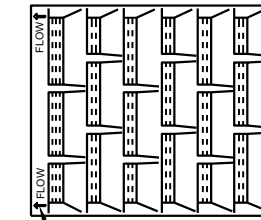

1" DIAGONAL BARS WITH 1 1/2" OPENINGS

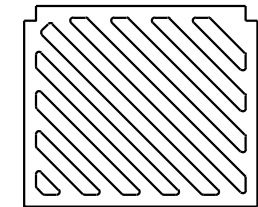

**SPECIAL GRATE FOR TYPE "A" COVER**

(MEASURES 19 3/4" X 17" X 1 7/8")  
(NOTED AS TYPE A-S ON DRAINAGE TABLE)

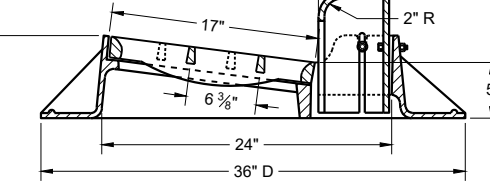
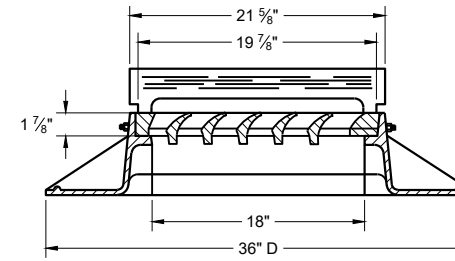
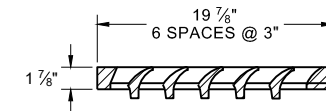

**TYPE "A"**

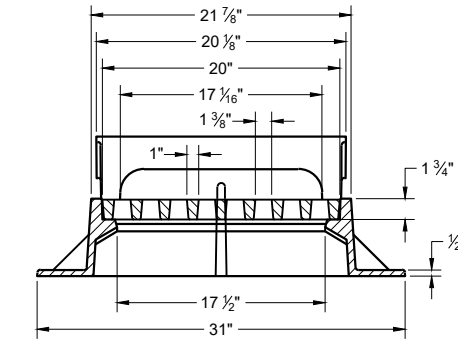
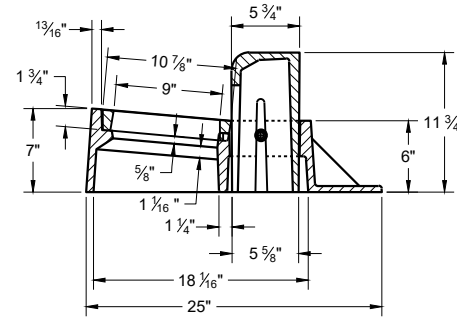

**TYPE "Z"**

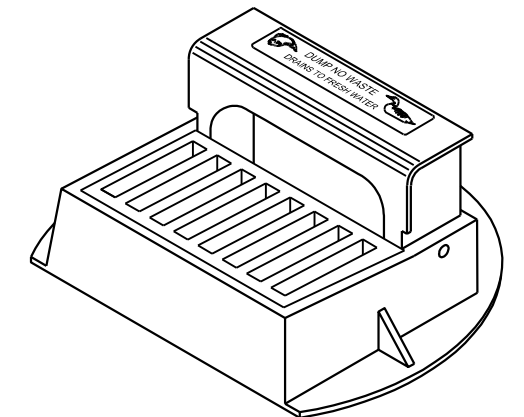

**INLET COVERS TYPES A, H, A-S, H-S AND Z**

STATE OF WISCONSIN  
DEPARTMENT OF TRANSPORTATION

APPROVED  
July 2023 DATE /S/ Rodney Taylor  
ROADWAY STANDARDS DEVELOPMENT UNIT SUPERVISOR



**GENERAL NOTES**

DETAILS OF CONSTRUCTION, MATERIALS AND WORKMANSHIP NOT SHOWN ON THIS DRAWING SHALL CONFORM TO THE PERTINENT REQUIREMENTS OF THE STANDARD SPECIFICATIONS AND THE APPLICABLE SPECIAL PROVISIONS.

DETAIL DRAWINGS FOR PROPOSED ALTERNATE DESIGNS FOR INLET COVERS SHALL BE SUBMITTED TO THE ENGINEER FOR APPROVAL PROVIDING THAT SUCH ALTERNATE DESIGNS MAKE PROVISION FOR EQUIVALENT CAPACITY AND STRENGTH.

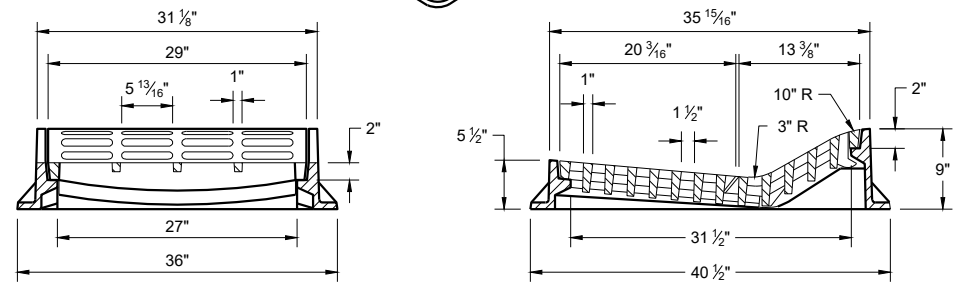
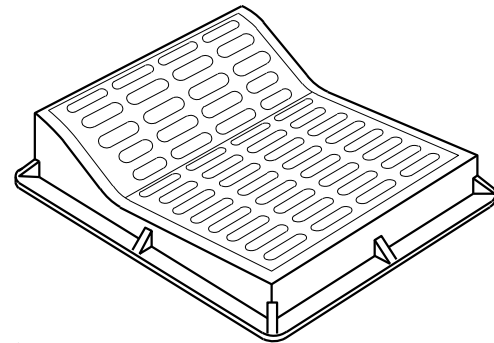

**TYPE "F"**

USE WITH TYPES "A" AND "D" CONCRETE CURB AND GUTTER, 36"

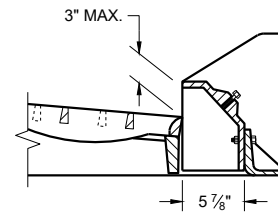

**ALTERNATIVE CURB BOX FOR TYPE "HM" COVER**

USE WITH TYPES "G" AND "J" CONCRETE CURB AND GUTTER, 30 INCH NOTED AS TYP "HM-GJ" ON DRAINAGE TABLE

NOTE: SPECIAL GRATE FOR THE TYPE "H" COVER MAY ALSO BE USED FOR THE TYPE "HM-GJ" COVER.

NOTED AS TYPE HM-GJ-S ON THE DRAINAGE TABLE.

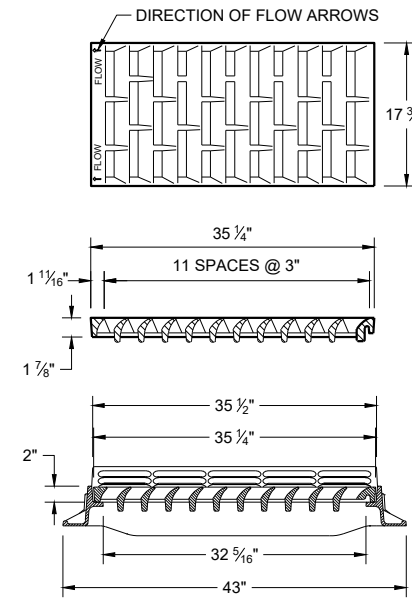

**TYPE "HM"**

USE WITH TYPES "A" AND "D" CONCRETE CURB AND GUTTER, 36"

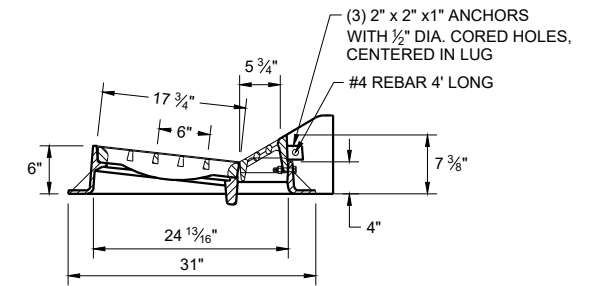
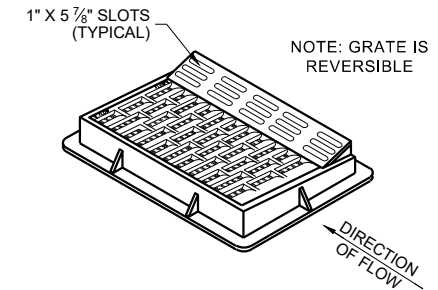

NOTE: SPECIAL GRATE FOR THE TYPE "H" COVER MAY ALSO BE USED FOR THE TYPE "HM-GJ" COVER.

NOTED AS TYPE HM-GJ-S ON THE DRAINAGE TABLE.

6

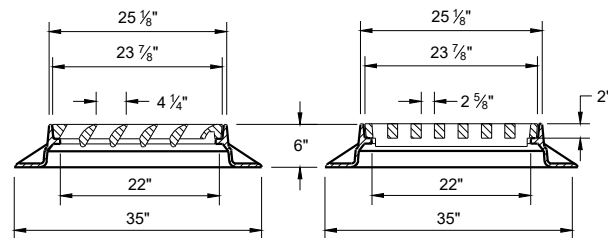
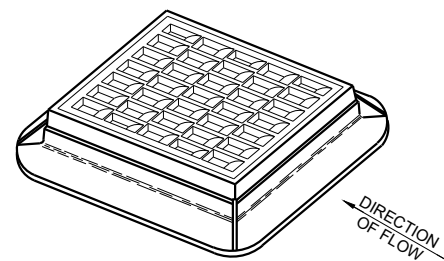

**TYPE "S"**

SDD 08A05-20C

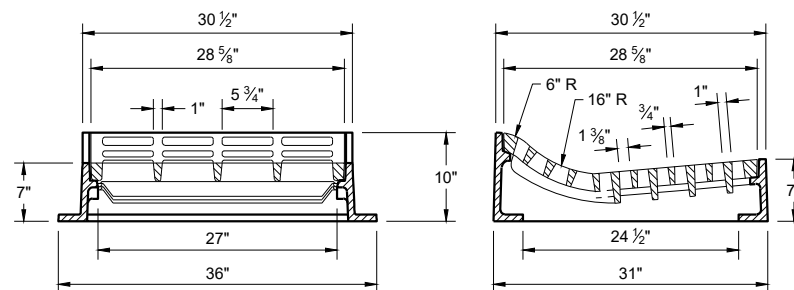
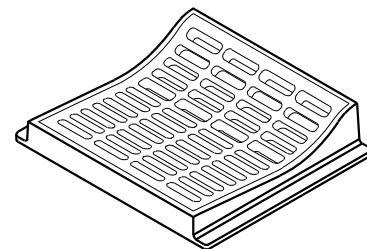

**TYPE "T"**

USE WITH TYPES "R" AND "T" CONCRETE CURB AND GUTTER, 36"

6

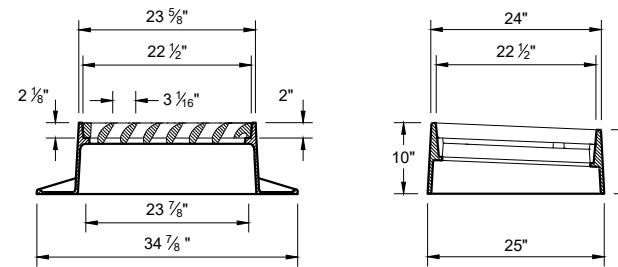
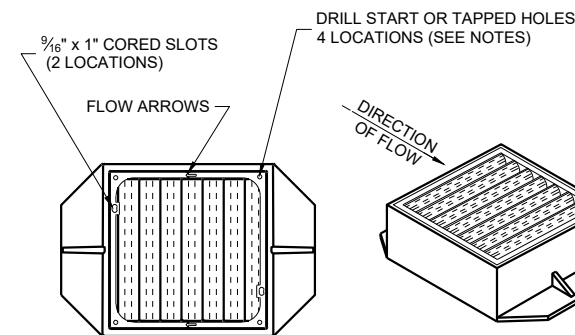

**TYPE "V"**

NOTES: ALL HARDWARE TO BE SUPPLIED BY CASTING MANUFACTURER ALL DRILLING AND TAPPING GRATES AND FRAMES BY CASTING MANUFACTURER

TYPE V  
 FRAME - CAST GRAY IRON ASTM A48 CLASS 40A  
 3/8" DIA. X 1/16" DRILL START IN 4 LOCATIONS  
 GRATE - CAST GRAY IRON ASTM A-48, CLASS 35B

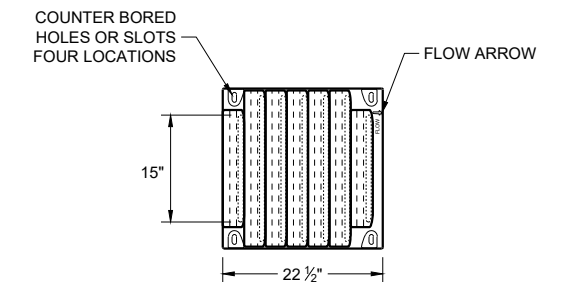

**BOLT DOWN GRATE FOR TYPE "V" COVER**

NOTES: ALL HARDWARE TO BE SUPPLIED BY CASTING MANUFACTURER NOTED AS TYPE "V-B" ON DRAINAGE TABLE

TAP 1/2" -13 HOLES IN FOUR LOCATIONS IN FRAME TO BOLT GRATE FRAME - CAST GRAY IRON ASTM A48 CLASS 40A

GRATE - CAST DUCTILE IRON ASTM A536, 55+KSI YIELD BOLTS - 1/2" -13 STAINLESS STEEL BOLTS WITH WASHERS TORQUE BOLTS TO MANUFACTURER SPECIFICATION DO NOT OVERTIGHTEN.

**INLET COVERS  
 TYPES F, HM, HM-S, S, T, V,  
 HM-GJ AND HM-GJ-S**

STATE OF WISCONSIN  
 DEPARTMENT OF TRANSPORTATION

APPROVED  
 July 2023 /S/ Rodney Taylor  
 DATE ROADWAY STANDARDS DEVELOPMENT  
 FHWA UNIT SUPERVISOR

SDD 08A05-20C

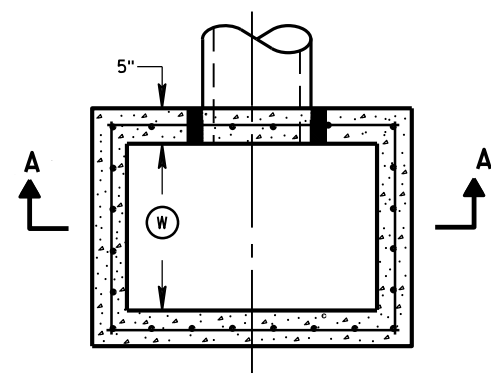

PLAN VIEW

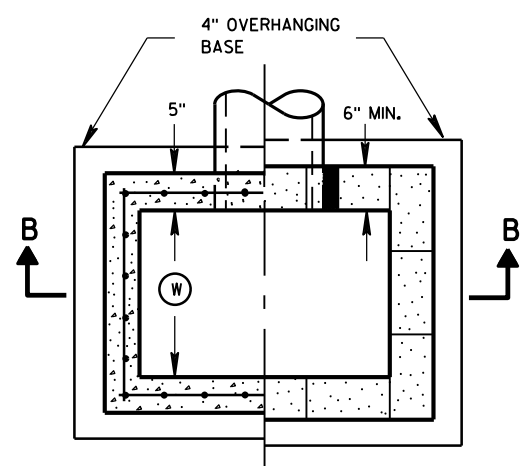

PLAN VIEW

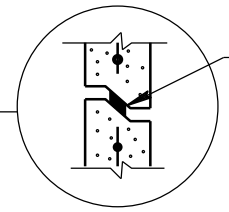

RISER JOINTS TO BE SEALED WITH A BUTYL RUBBER SEAL PER SEALANT MANUFACTURERS RECOMMENDATIONS CONFORMING TO ASTM C 990 (TYP)

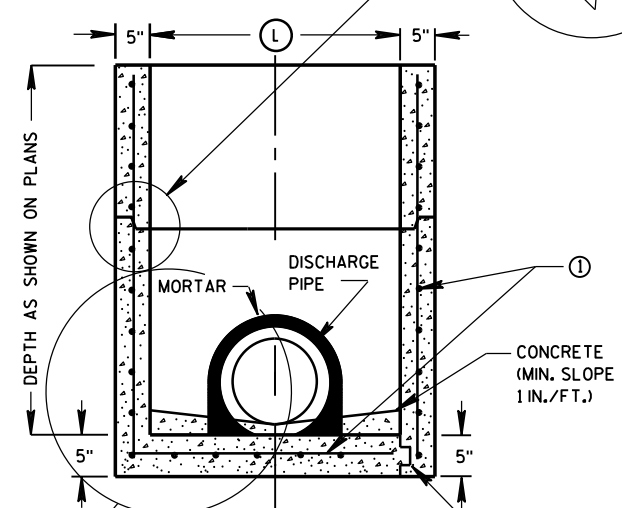

SECTION A-A

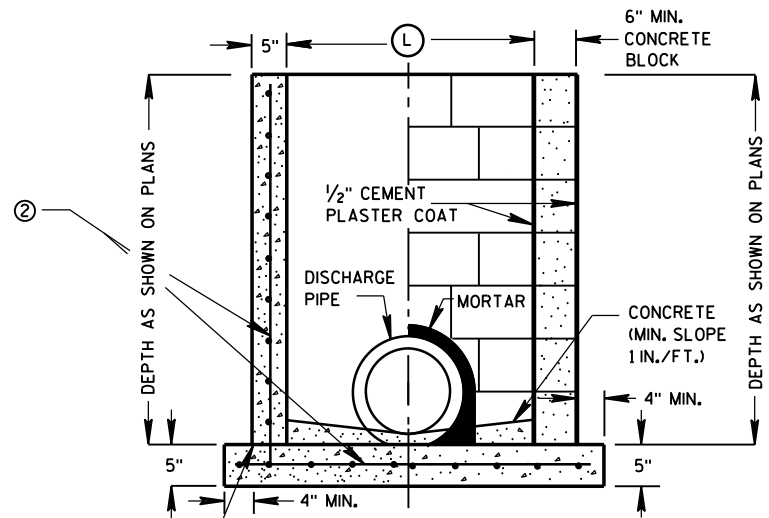

SECTION B-B

PRECAST REINFORCED CONCRETE WITH MONOLITHIC BASE  
 PRECAST REINFORCED CONCRETE WITH INTEGRAL BASE  
 KEYWAY

CONSTRUCTION JOINT  
 CAST-IN-PLACE REINFORCED CONCRETE  
 CONCRETE BLOCK WITH CAST-IN-PLACE OR PRECAST REINFORCED CONCRETE BASE ①

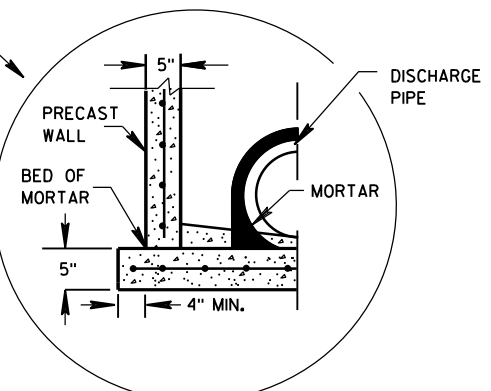

SEPARATE PRECAST REINFORCED CONCRETE BASE OPTION

**GENERAL NOTES**

DETAILS OF CONSTRUCTION, MATERIALS AND WORKMANSHIP NOT SHOWN ON THIS DRAWING SHALL CONFORM TO THE PERTINENT REQUIREMENTS OF THE STANDARD SPECIFICATIONS AND THE APPLICABLE SPECIAL PROVISIONS.

UNLESS OTHERWISE AUTHORIZED IN WRITING BY THE ENGINEER, THE CONTRACTOR SHALL NOT ORDER AND DELIVER PRECAST INLET UNITS REQUIRED FOR THE PROJECT UNTIL A LIST OF SIZES IS FURNISHED BY THE ENGINEER.

DETAILED DRAWINGS FOR PROPOSED ALTERNATE DESIGNS FOR UNDERGROUND DRAINAGE STRUCTURES SHALL BE SUBMITTED TO THE ENGINEER FOR APPROVAL PROVIDING THAT SUCH ALTERNATE DESIGNS MAKE PROVISION FOR EQUIVALENT CAPACITY AND STRENGTH.

ALL PRECAST INLET UNITS SHALL CONFORM TO THE PERTINENT REQUIREMENTS OF ASTM C 913.

ALL DRAINAGE STRUCTURES ARE DESIGNATED ON THE PLANS AS "MANHOLES 3X3-L", "CATCH BASINS 4-B", "INLETS 2X3-H", ETC. THE FIRST NUMBERS DESIGNATES THE SIZE OF THE STRUCTURE, AND THE FOLLOWING LETTER DESIGNATES THE TYPE OF COVER TO BE USED TO COMPRISE THE COMPLETE UNIT.

BASES SHALL BE PLACED ON A BED OF MATERIAL AT LEAST 6 INCHES IN DEPTH, WHICH MEETS THE REQUIREMENTS OF FOUNDATION BACKFILL. THIS BEDDING SHALL BE COMPACTED AND PROVIDE UNIFORM SUPPORT FOR THE ENTIRE AREA OF THE BASE.

ALL BAR STEEL REINFORCEMENT SHALL BE EMBEDDED 2 INCHES CLEAR UNLESS OTHERWISE SHOWN OR NOTED.

PRECAST REINFORCED RISERS SHALL HAVE A TONGUE AND GROOVE JOINT WITH TONGUE UP OR DOWN.

4" OVERHANGING BASES ARE REQUIRED FOR CAST-IN-PLACE REINFORCED CONCRETE AND CONCRETE BLOCK INSTALLATIONS. 4" OVERHANG IS REQUIRED WHEN SEPARATE PRECAST BASE IS PROVIDED. OVERHANG IS NOT REQUIRED ON PRECAST STRUCTURES WITH AN INTEGRAL OR MONOLITHIC BASE.

MAXIMUM INSIDE PIPE DIAMETER DETERMINED BY 3 INCH CLEARANCE ON EACH SIDE OF THE OUTSIDE WALL OF THE PIPE. SEE DETAIL "A". ASSUMES PIPE ENTERS PERPENDICULAR TO THE STRUCTURE.

① FOR PRECAST INLETS PROVIDE REINFORCING STEEL IN ACCORDANCE TO ASTM C 913.

② CONTRACTOR TO PROVIDE DRAWING(S) STAMPED BY A PROFESSIONAL ENGINEER FOR STEEL REINFORCING DESIGN FOR CAST-IN-PLACE STRUCTURES.

**INLET COVER MATRIX**

INLET SIZE	INLET COVER TYPE		ALL A'S	ALL B'S	BW	F	ALL H'S	S	T	V	WM
	WIDTH (W) (FT)	LENGTH (L) (FT)									
2X2-FT	2	2	X	X				X		X	
2X2.5-FT	2	2.5			X			X	X	X	X
2X3-FT	2	3					X				
2.5X3-FT	2.5	3				X					

**PIPE MATRIX**

INLET SIZE	MAXIMUM INSIDE PIPE DIAMETER	
	WIDTH (IN)	LENGTH (IN)
2X2-FT	12	12
2X2.5-FT	12	18
2X3-FT	12	24
2.5X3-FT	18	24

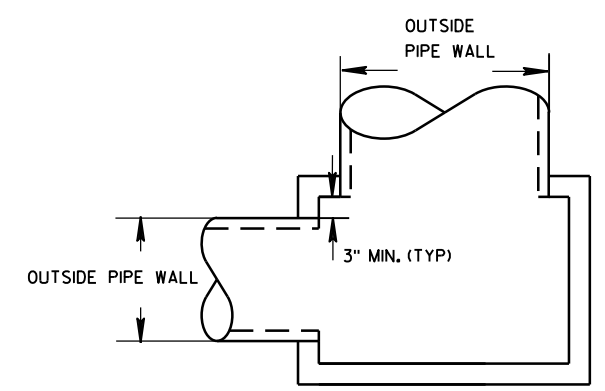

DETAIL "A"

**INLETS 2X2-FT, 2X2.5-FT, 2X3-FT AND 2.5X3-FT**

INLETS 2X2-FT, 2X2.5-FT, 2X3-FT AND 2.5X3-FT

STATE OF WISCONSIN  
 DEPARTMENT OF TRANSPORTATION

APPROVED  
 Sept., 2016 /S/ Rodney Taylor  
 DATE ROADWAY STANDARDS DEVELOPMENT  
 FHWA UNIT SUPERVISOR

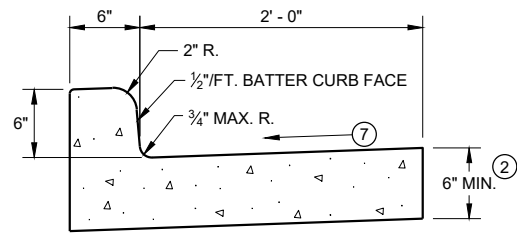

**TYPES A<sup>①</sup> & D**

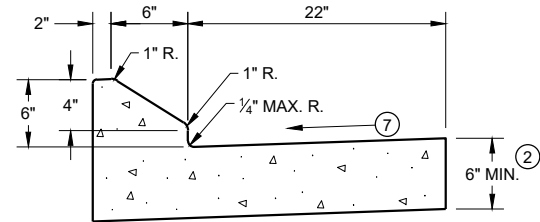

**6" SLOPED CURB TYPES G<sup>①</sup> & J**

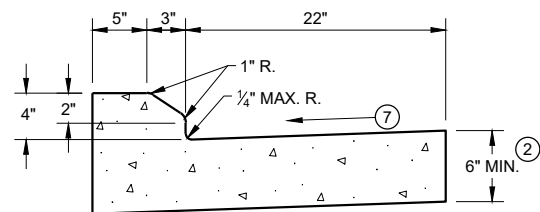

**4" SLOPED CURB TYPES G<sup>①</sup> & J**

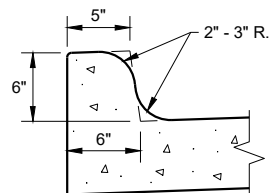

**TYPES K<sup>①</sup> & L**  
(OPTIONAL CURB SHAPE)

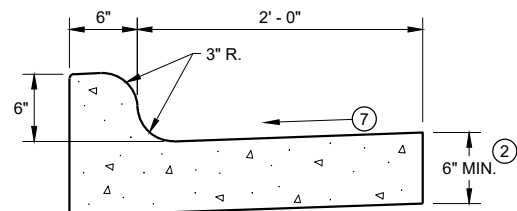

**TYPES K<sup>①</sup> & L**  
**CONCRETE CURB AND GUTTER 30"**

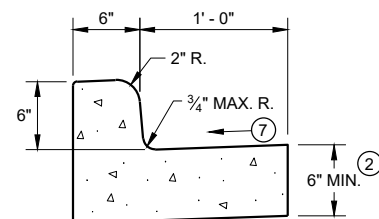

**TYPES A<sup>①</sup> & D**  
**CONCRETE CURB AND GUTTER 18"**

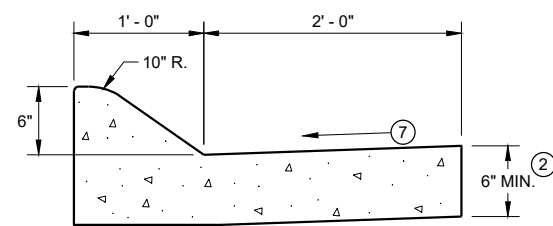

**6" SLOPED CURB TYPES A<sup>①</sup> & D**

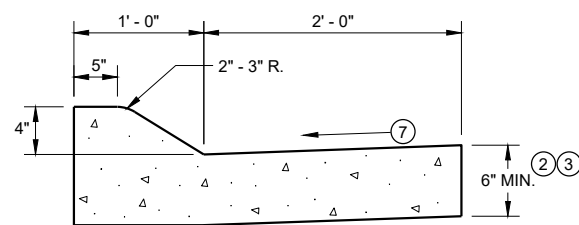

**4" SLOPED CURB TYPES A<sup>①</sup> & D**  
**CONCRETE CURB AND GUTTER 36"**

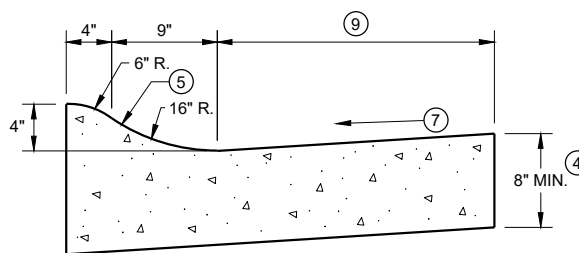

**4" SLOPED CURB TYPES R<sup>①</sup> & T**

TBT & TBTT	X
30"	22"
36"	28"

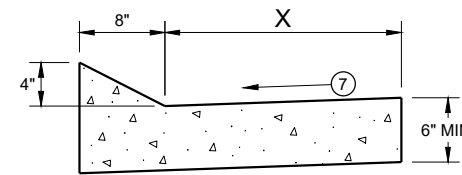

**TYPES TBT & TBTT<sup>①</sup>**  
**CONCRETE CURB AND GUTTER**

**PAVEMENT THICKNESS AND MAXIMUM CONCRETE PANEL WIDTH TABLE**

PAVEMENT THICKNESS	MAXIMUM PANEL WIDTH
LESS THAN 10"	12'
10" & ABOVE	15'

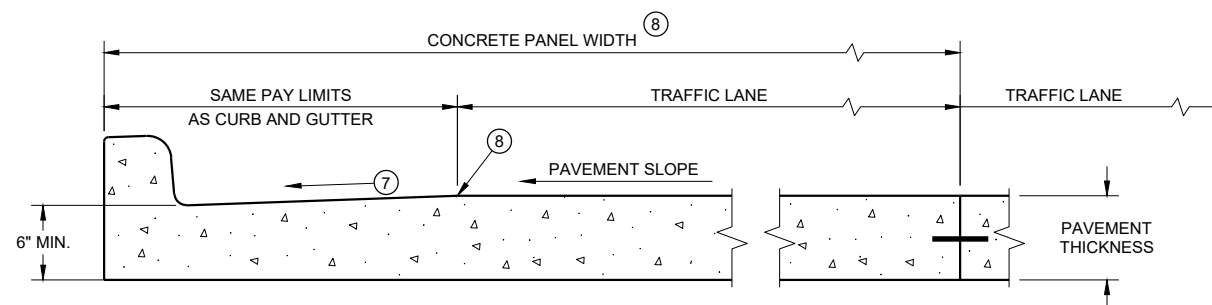

**PARTIAL SECTION OF PAVEMENT\* WITH INTEGRAL CURB AND GUTTER**

\* BIKE LANE IS NOT SHOWN

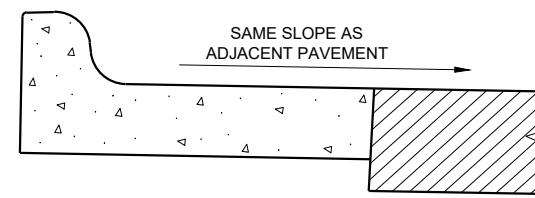

**REVERSE SLOPE GUTTER<sup>⑥</sup>**  
(TYPICAL FOR ALL CURB & GUTTER TYPES)

**GENERAL NOTES**

DETAILS OF CONSTRUCTION AND WORKMANSHIP NOT SHOWN ON THIS DRAWING SHALL CONFORM TO THE PERTINENT REQUIREMENTS OF THE CONTRACT.

PAVEMENT TIES AND TIE BARS SHALL BE EPOXY COATED IN CONFORMANCE WITH SUBSECTION 505.2.6.2 OF THE STANDARD SPECIFICATIONS.

INTEGRAL CURB AND GUTTER SHALL CONFORM TO THE DETAILS SHOWN FOR CONCRETE CURB AND GUTTER INCLUDING THE TRANSVERSE GUTTER SLOPE.

UNLESS OTHERWISE SHOWN ON THE TYPICAL CROSS SECTIONS, THE BASE AGGREGATE AND COMMON EXCAVATION LIMITS ARE 2' - 0" BEHIND THE BACK OF CURBS.

- ① TIE BARS ARE REQUIRED FOR CURB AND GUTTERS TYPES A, G, K, R, AND TBTT.
- ② THE BOTTOM OF CURB AND GUTTER MAY BE CONSTRUCTED EITHER LEVEL OR PARALLEL TO THE SLOPE OF THE SUBGRADE OR BASE AGGREGATE PROVIDED A 6" MINIMUM GUTTER THICKNESS IS MAINTAINED.
- ③ USE 8" MINIMUM GUTTER THICKNESS WHEN USED WITH AN ADJACENT CONCRETE TRUCK APRON PLACED BEHIND BACK OF CURB.
- ④ THE BOTTOM OF CURB AND GUTTER MAY BE CONSTRUCTED EITHER LEVEL OR PARALLEL TO THE SLOPE OF THE SUBGRADE OR BASE AGGREGATE PROVIDED A 8" MINIMUM GUTTER THICKNESS IS MAINTAINED.
- ⑤ UNLESS OTHERWISE NOTED, FOR STAKING PURPOSES THE FACE OF CURB IS 6" FROM THE BACK OF CURB.
- ⑥ WHEN REVERSE SLOPE GUTTER IS REQUIRED, THE LOCATION(S) WILL BE SHOWN ELSEWHERE IN THE PLAN.
- ⑦ USE 4% GUTTER CROSS SLOPE UNLESS OTHERWISE NOTED IN THE PLANS.
- ⑧ INCLUDE LONGITUDINAL JOINT AND TIE BARS ALONG LANE EDGE WHEN CONCRETE PANEL WIDTH EXCEEDS THE MAXIMUM WIDTH PER TABLE BELOW. LONGITUDINAL JOINT(S) ARE NOT ALLOWED WITHIN TRAFFIC LANES AND BIKE LANES. LONGITUDINAL JOINT MAY BE SAWED.
- ⑨ CONCRETE CURB AND GUTTER 4-INCH SLOPED 30-INCH TYPE "R" AND "T" = 17 INCHES  
CONCRETE CURB AND GUTTER 4-INCH SLOPED 36-INCH TYPE "R" AND "T" = 23 INCHES



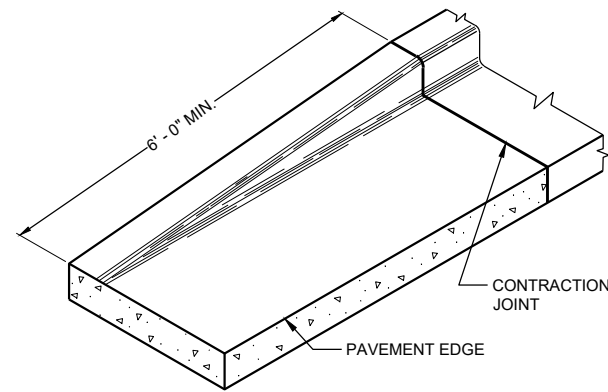

**END SECTION CURB AND GUTTER**

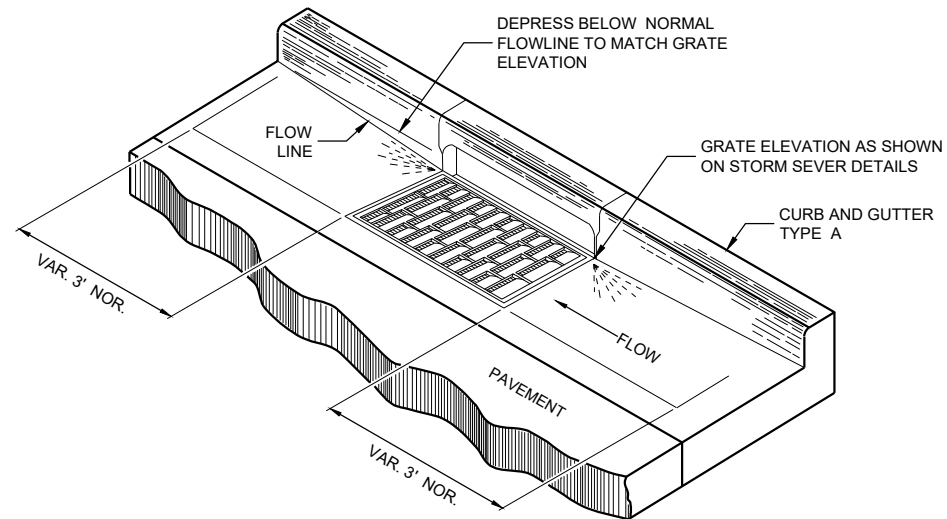

**DETAIL OF CURB AND GUTTER AT INLETS**

(TYPICAL H INLET COVER SHOWN)

**GENERAL NOTES**

DETAILS OF CONSTRUCTION AND WORKMANSHIP NOT SHOWN ON THIS DRAWING SHALL CONFORM TO THE PERTINENT REQUIREMENTS OF THE CONTRACT.

PAVEMENT TIES AND TIE BARS SHALL BE EPOXY COATED IN CONFORMANCE WITH SUBSECTION 505.2.6.2 OF THE STANDARD SPECIFICATIONS.

UNLESS OTHERWISE SHOWN ON THE TYPICAL CROSS SECTIONS, THE BASE AGGREGATE AND COMMON EXCAVATION LIMITS ARE 2' - 0" BEHIND THE BACK OF CURBS.

- ① TIE BARS ARE REQUIRED FOR CURB AND GUTTERS TYPES A, G, K, R, AND TBTT.
- ② THE BOTTOM OF CURB AND GUTTER MAY BE CONSTRUCTED EITHER LEVEL OR PARALLEL TO THE SLOPE OF THE SUBGRADE OR BASE AGGREGATE PROVIDED A 6" MINIMUM GUTTER THICKNESS IS MAINTAINED.
- ⑩ REFER TO SDD 08D18 AND 08D19 FOR ADDITIONAL DRIVEWAY ENTRANCE CURB DETAILS.
- ⑪ PLACE 1" THICK EXPANSION JOINT MATERIAL BETWEEN VERTICAL FACE CURB TYPES EXTENDING FROM THE TOP OF CURB TO 1 INCH BELOW THE ADJOINING CONCRETE SURFACE. RIGID CONCRETE STRUCTURES INCLUDE RAISED CONCRETE MEDIANS, CONCRETE SAFETY ISLANDS, SPLITTER ISLANDS, OR LOCATIONS IDENTIFIED ON THE PLANS.

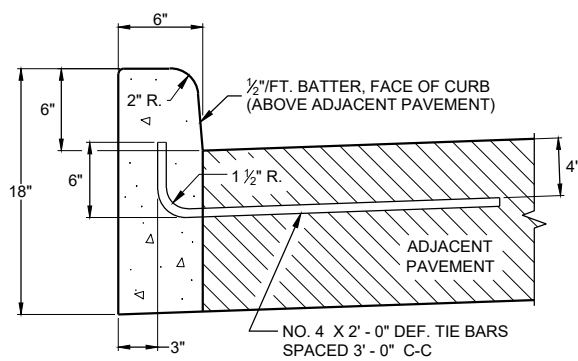

**TYPES A<sup>①</sup> & D**

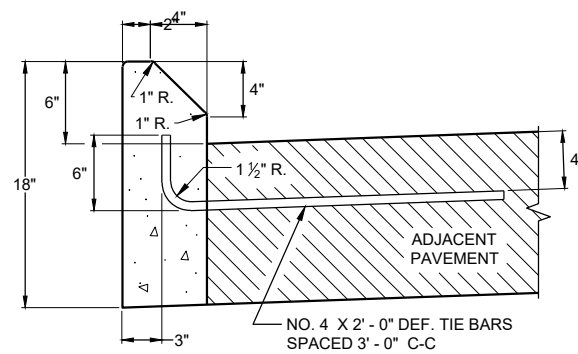

**TYPES G<sup>①</sup> & J  
CONCRETE CURB**

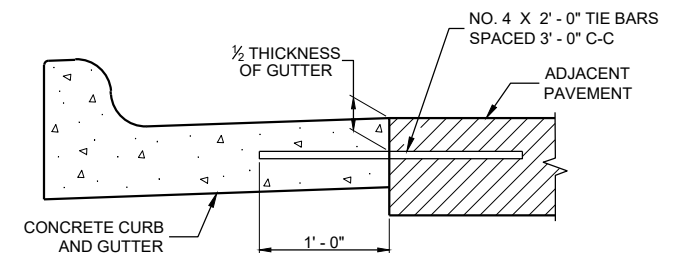

**TYPICAL TIE BAR LOCATION<sup>①</sup>**

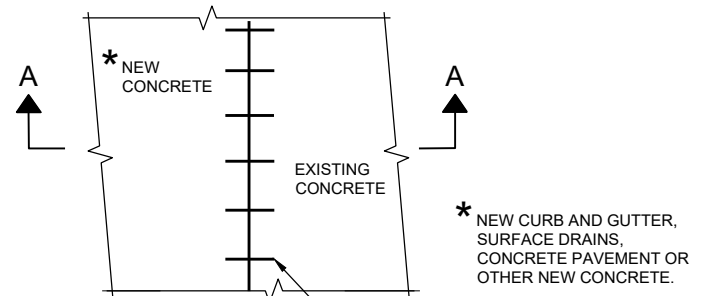

**PLAN VIEW**

\* NEW CURB AND GUTTER, SURFACE DRAINS, CONCRETE PAVEMENT OR OTHER NEW CONCRETE.

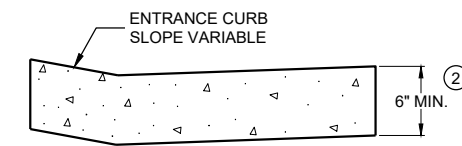

**DRIVEWAY ENTRANCE CURB<sup>⑩</sup>  
(WHEN DIRECTED BY THE ENGINEER)**

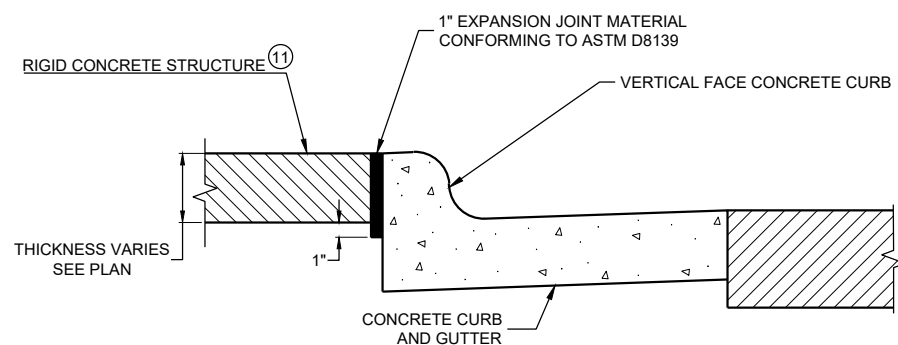

**EXPANSION JOINT DETAIL FOR VERTICAL CURB ABUTTING A RIGID STRUCTURE<sup>⑪</sup>**

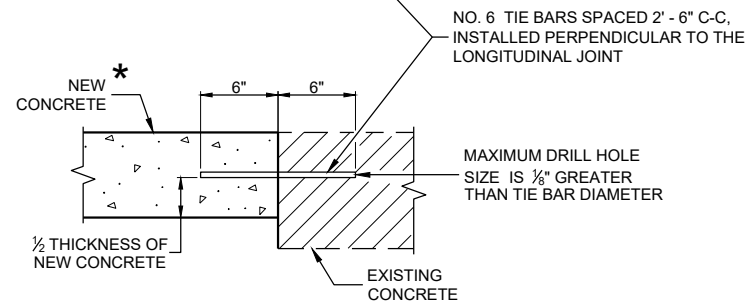

**SECTION A - A  
TIE BARS DRILLED INTO EXISTING PAVEMENT**

**CONCRETE CURB, TIES AND CURB AND GUTTER APPLICATIONS**

STATE OF WISCONSIN  
DEPARTMENT OF TRANSPORTATION

APPROVED  
DATE May 2023 /S/ Rodney Taylor  
ROADWAY STANDARDS DEVELOPMENT ENGINEER

FHWA

NOTE: TAPER CURB ENDS TO GUTTER IN 1' - 0"

### ASPHALTIC FLUME

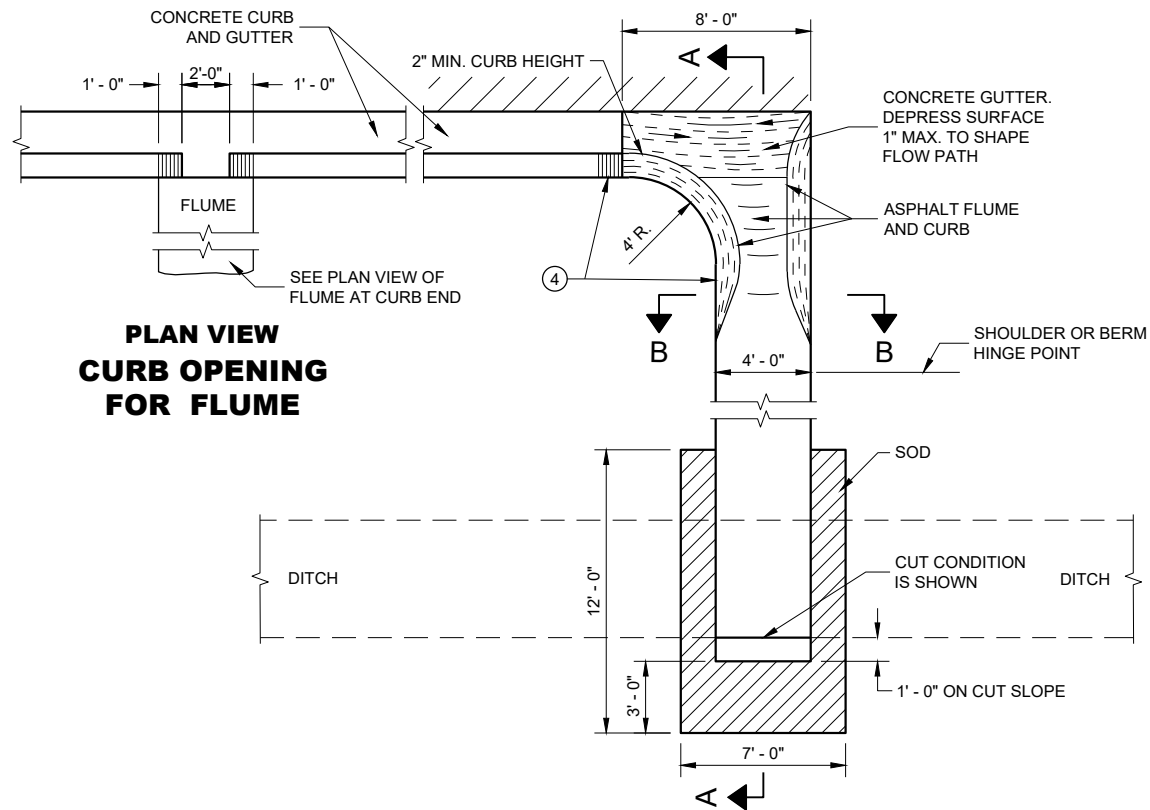

**PLAN VIEW  
CURB OPENING  
FOR FLUME**

**PLAN VIEW  
FLUME AT CURB END**

### GENERAL NOTES

DETAILS OF CONSTRUCTION, MATERIALS AND WORKMANSHIP NOT SHOWN ON THIS DRAWING SHALL CONFORM TO PERTINENT REQUIREMENTS OF THE STANDARD SPECIFICATIONS AND APPLICABLE SPECIAL PROVISIONS.

4" X 4" - W3.0 X W3.0 CONCRETE REINFORCEMENT SHALL BE IN ACCORDANCE WITH AASHTO SPECIFICATION M55.

- ① JOINTS SHALL BE 1/8" TO 1/4" WIDE BY 1 1/2" DEEP AND SPACED AT UNIFORM INTERVALS OF APPROXIMATELY 4 FEET.
- ② GEOTEXTILE TYPE "R" SHALL UNDERLAY THE FULL LENGTH AND WIDTH OF THE CONCRETE SURFACE DRAIN AND RIPRAP.
- ③ CONCRETE SURFACE DRAIN WITHOUT CURB AND GUTTER MAY BE USED ON BACKSLOPES WHEN SPECIFIED.
- ④ ANGLE OF FLUME IN RELATION TO BACK OF CURB TO BE CONSTRUCTED PER THE PLAN DETAILS OR AS DIRECTED BY THE ENGINEER. ANGLE OF FLUME MAY BE OTHER THAN 90 DEGREES AS SHOWN.

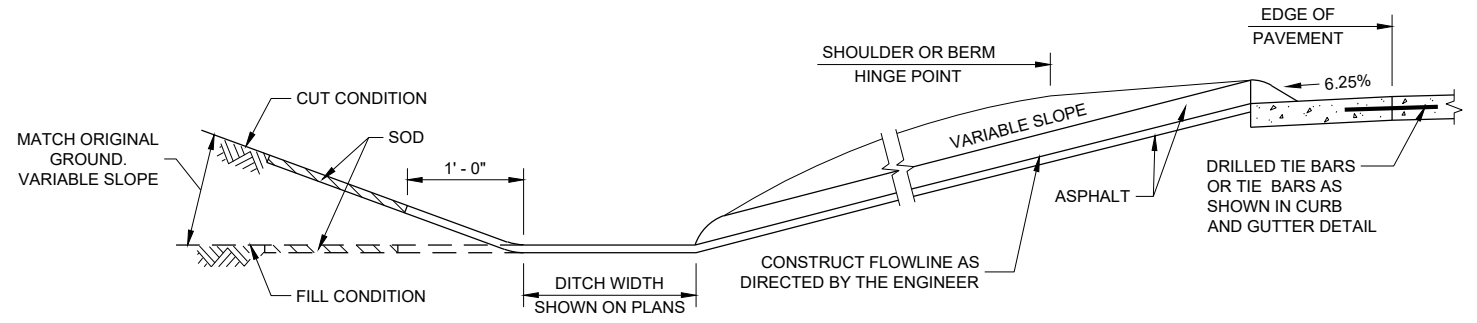

**SECTION A - A**

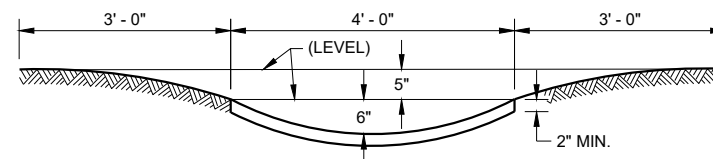

**SECTION B - B**

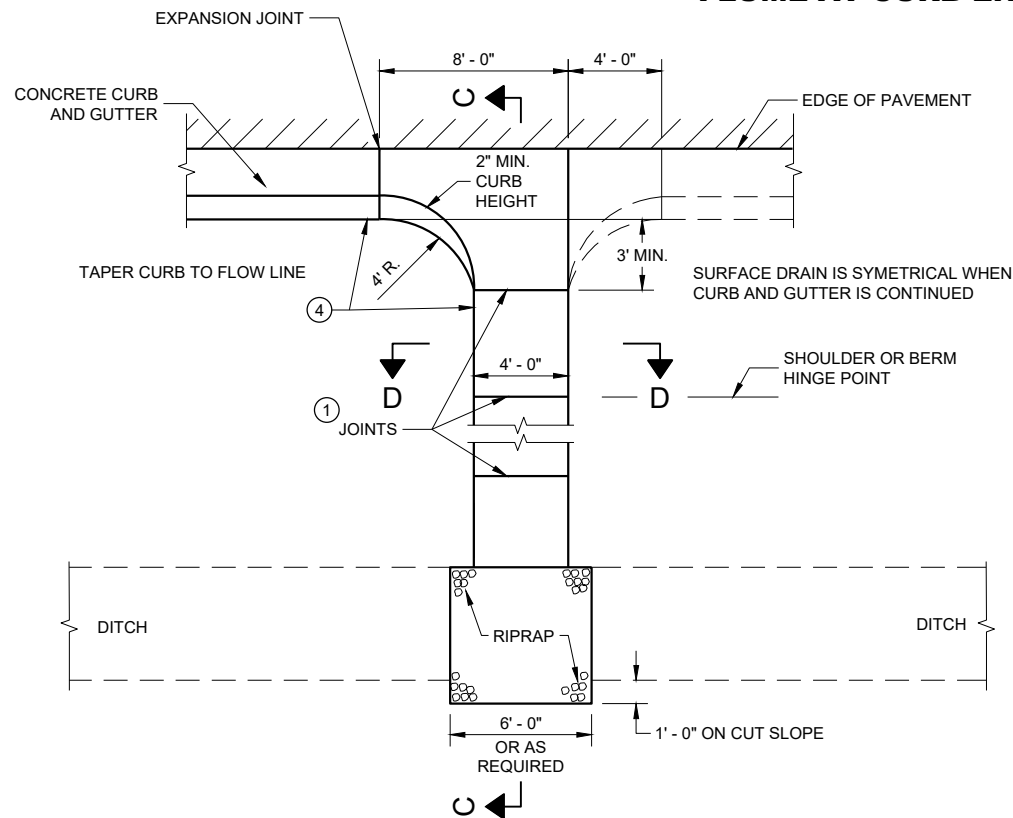

**PLAN VIEW  
CONCRETE SURFACE DRAIN**

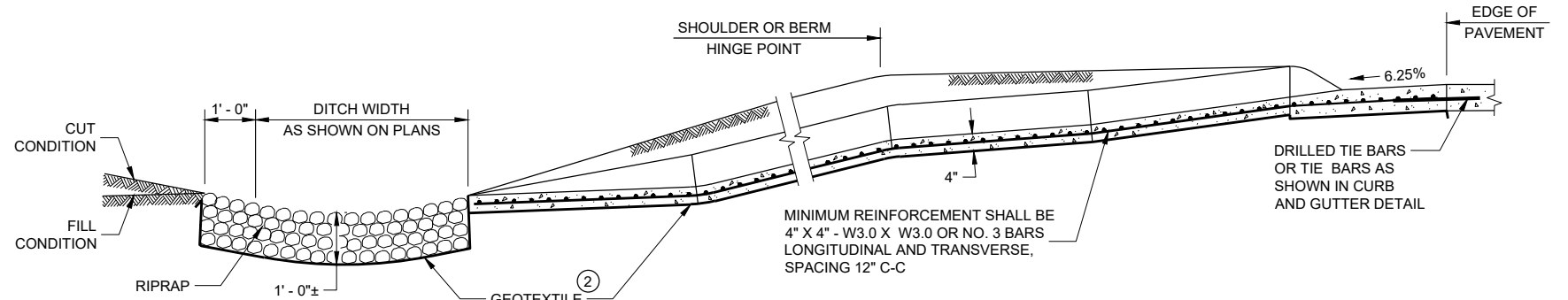

**SECTION C - C**

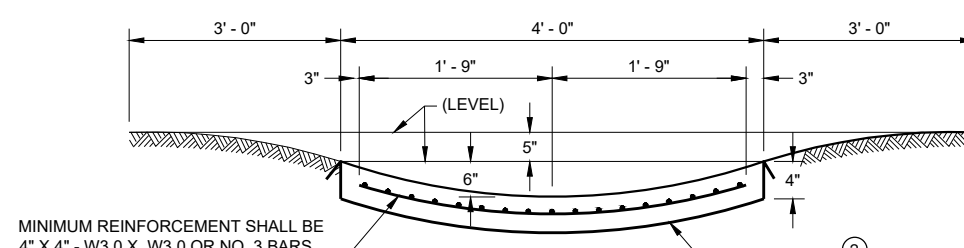

**SECTION D - D**

MINIMUM REINFORCEMENT SHALL BE 4" X 4" - W3.0 X W3.0 OR NO. 3 BARS LONGITUDINAL AND TRANSVERSE, SPACING 12" C-C

### CONCRETE SURFACE DRAINS AND ASPHALTIC FLUMES

STATE OF WISCONSIN  
DEPARTMENT OF TRANSPORTATION

APPROVED  
DATE May 2023 /S/ Rodney Taylor  
ROADWAY STANDARDS DEVELOPMENT  
ENGINEER

FHWA

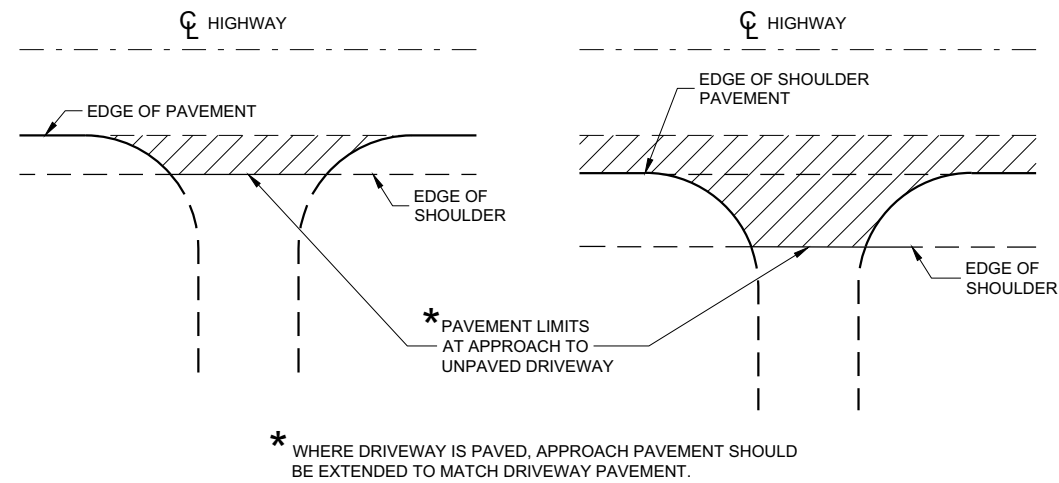

**PLAN VIEW**  
(UNPAVED SHOULDER ON HIGHWAY)

**PLAN VIEW**  
(PAVED SHOULDER ON HIGHWAY)

**RURAL DRIVEWAY INTERSECTION DETAIL  
(NO CURB AND GUTTER OR SIDEWALK)**

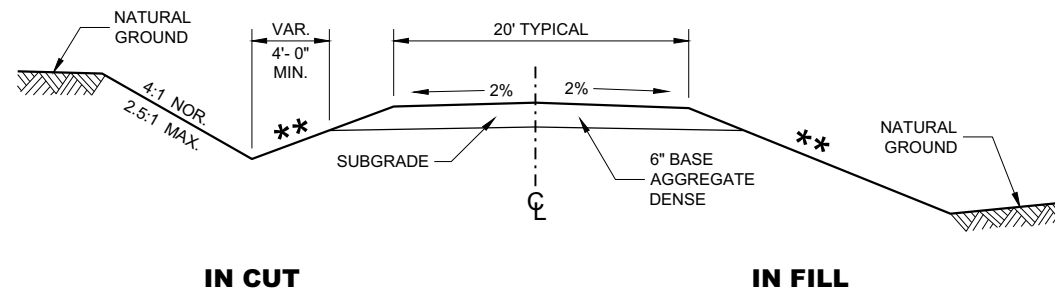

**TYPICAL CROSS SECTION FOR  
PRIVATE DRIVE OR FIELD ENTRANCE  
AGGREGATE SURFACE**

\*\* SLOPE CAN VARY WITH SPEED. SEE 11-45-30.6.2

POSTED SPEED MPH	MAX. SLOPE
<35	4:1
≥ 35 TO < 60	6:1
≥60	10:1

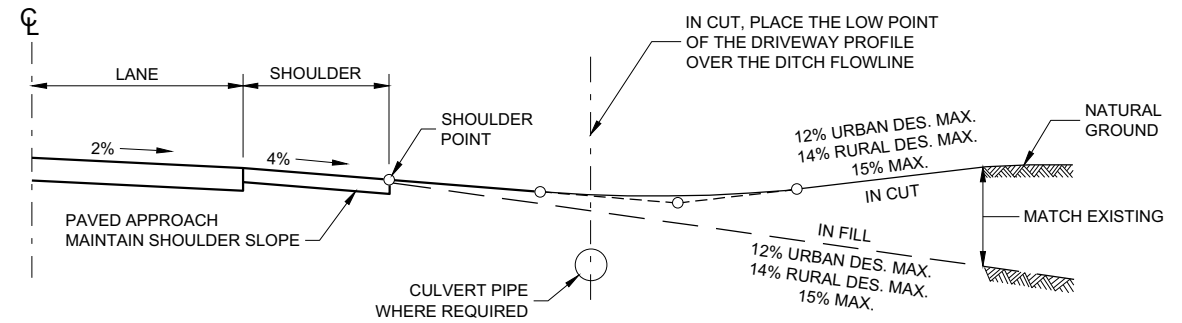

**TYPICAL DRIVEWAY PROFILES**

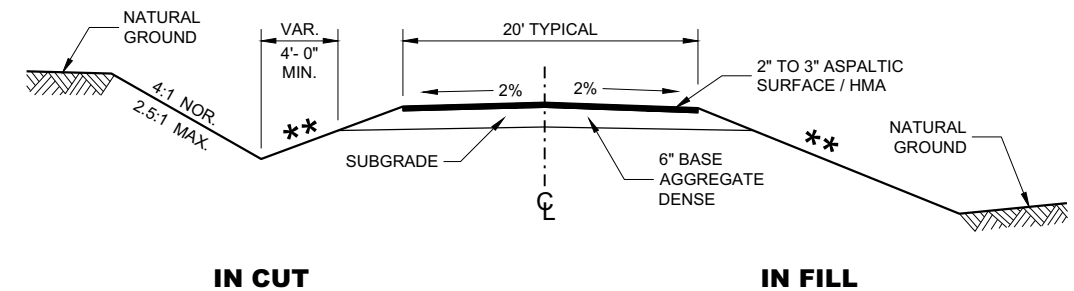

**TYPICAL CROSS SECTION FOR  
PRIVATE DRIVE OR FIELD ENTRANCE  
ASPHALTIC SURFACE**

**DRIVEWAYS WITHOUT CURB AND GUTTER**

---

STATE OF WISCONSIN  
DEPARTMENT OF TRANSPORTATION

---

APPROVED  
December 2017 /S/ Rodney Taylor  
DATE ROADWAY STANDARDS DEVELOPMENT UNIT SUPERVISOR

FHWA

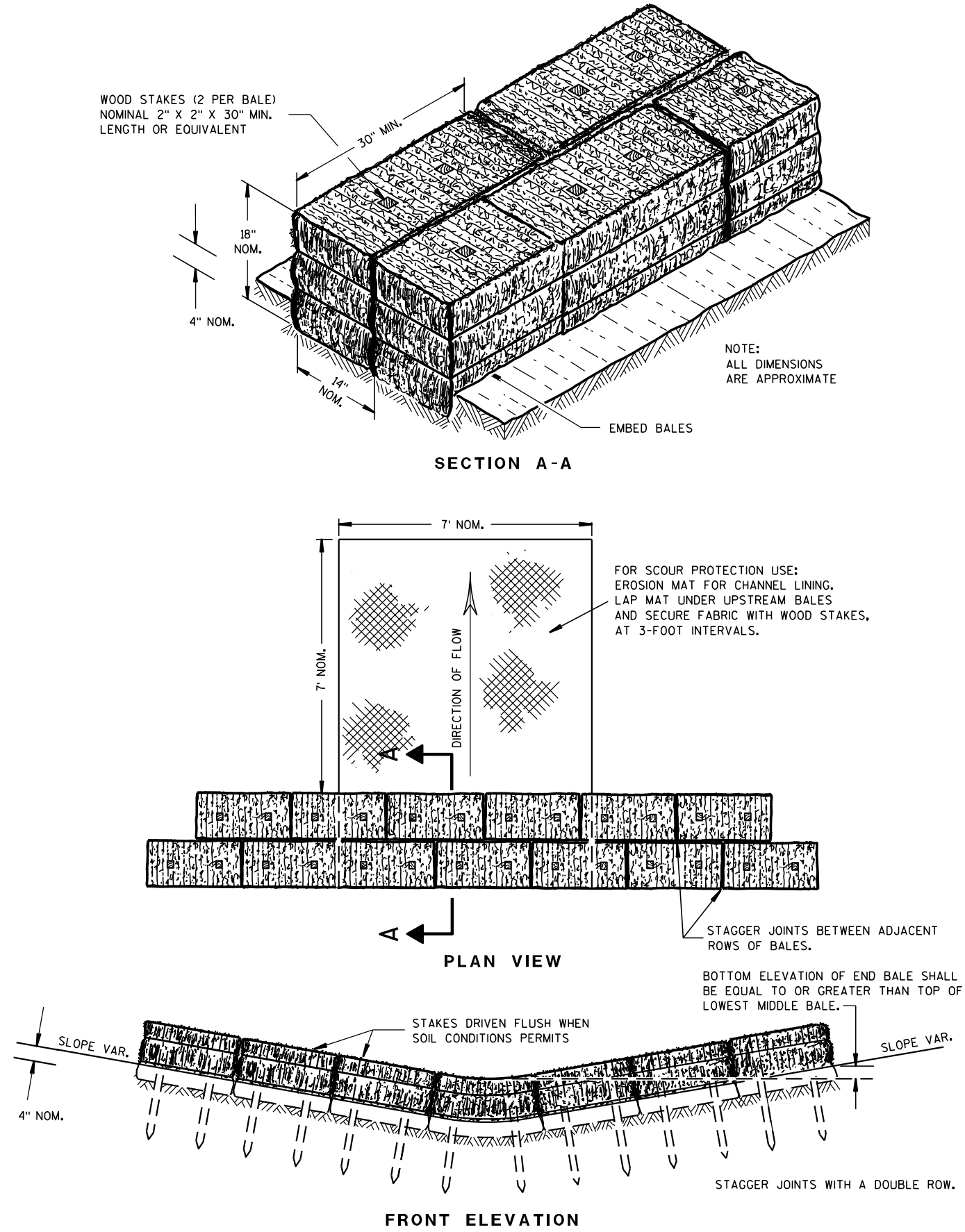

TEMPORARY DITCH CHECK USING EROSION BALES ①

GENERAL NOTES

DETAILS OF CONSTRUCTION, MATERIALS AND WORKMANSHIP NOT SHOWN ON THIS DRAWING SHALL CONFORM TO THE PERTINENT REQUIREMENTS OF THE STANDARD SPECIFICATIONS AND THE APPLICABLE SPECIAL PROVISIONS.

- ① TEMPORARY DITCH CHECKS EITHER EROSION BALES OR MANUFACTURED SHALL BE PAID FOR UNDER THE BID ITEM OF TEMPORARY DITCH CHECK. THE DEPARTMENT WILL NOT PAY FOR TEMPORARY DITCH CHECKS CONSTRUCTED OF A SINGLE ROW OF EROSION BALES.

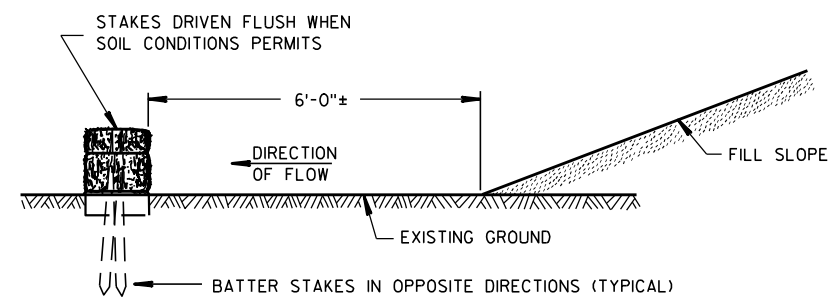
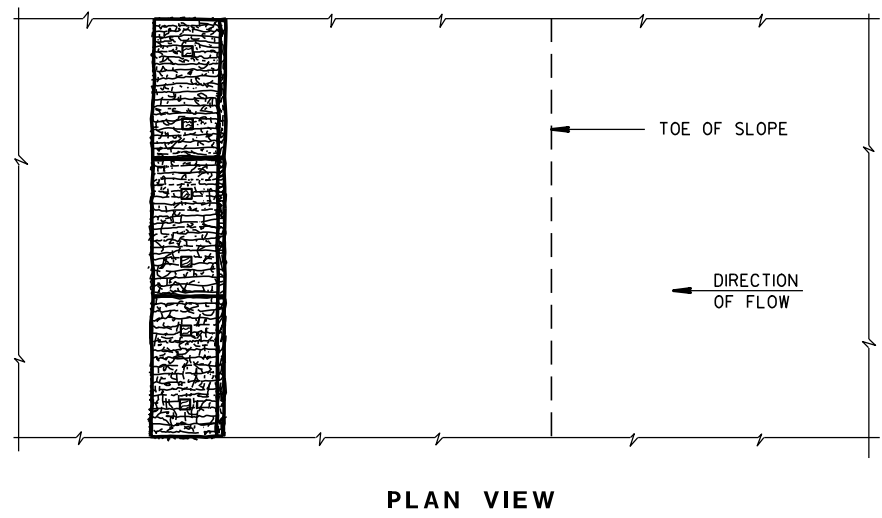
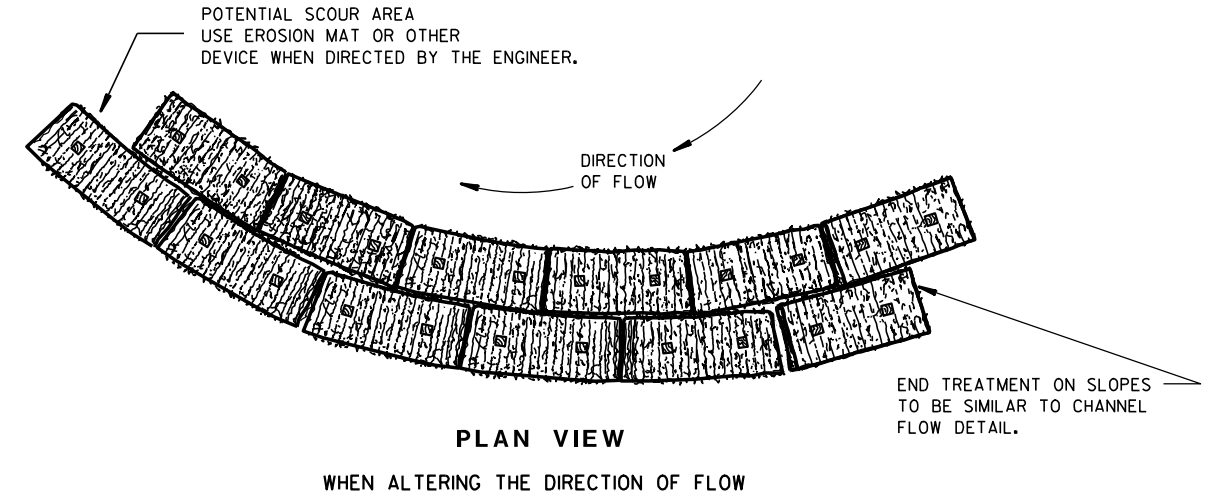

EROSION BALES FOR SHEET FLOW

TYPICAL INSTALLATIONS OF EROSION BALES / TEMPORARY DITCH CHECKS

STATE OF WISCONSIN DEPARTMENT OF TRANSPORTATION

APPROVED  
 6/04/02 /S/ Beth Canestra  
 DATE CHIEF ROADWAY DEVELOPMENT ENGINEER  
 FHWA

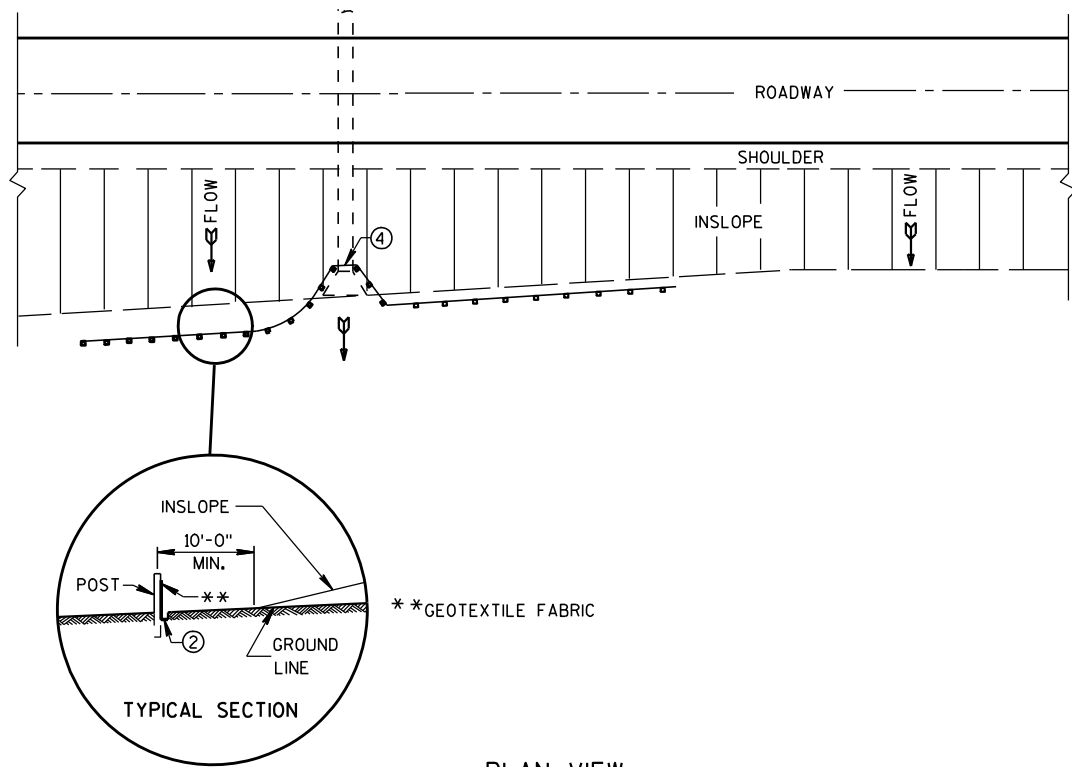

PLAN VIEW  
TYPICAL APPLICATION OF SILT FENCE

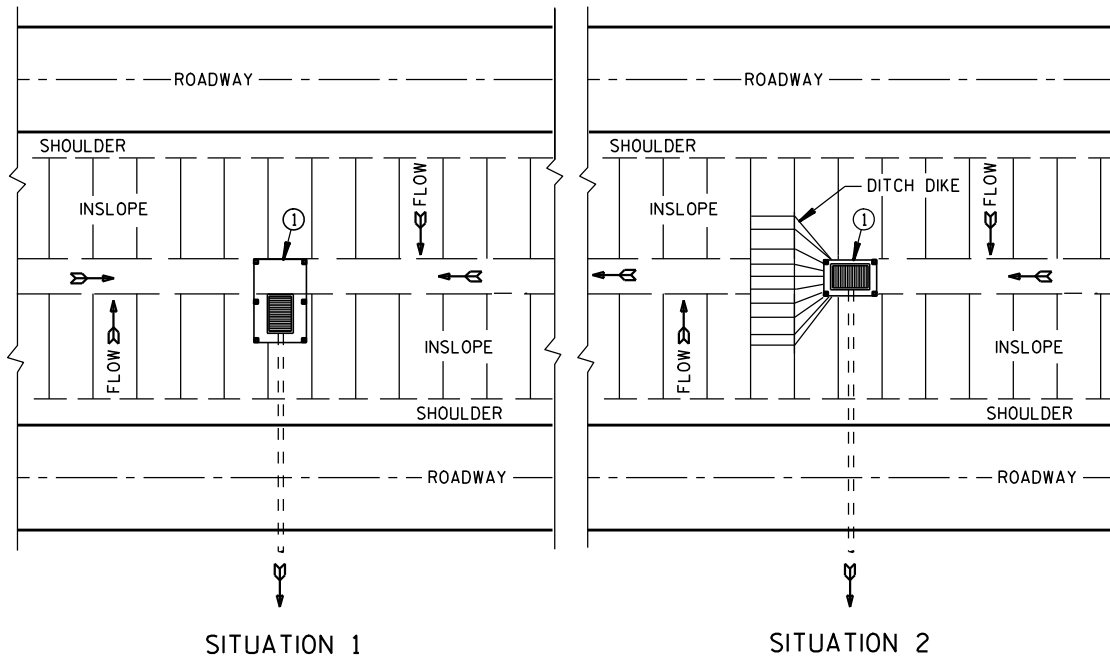

SITUATION 1 SITUATION 2  
PLAN VIEW  
SILT FENCE AT MEDIAN SURFACE DRAINS

**GENERAL NOTES**

DETAILS OF CONSTRUCTION NOT SHOWN ON THIS DRAWING SHALL CONFORM TO THE PERTINENT REQUIREMENTS OF THE STANDARD SPECIFICATIONS AND APPLICABLE SPECIAL PROVISIONS.

- ① HORIZONTAL BRACE REQUIRED WITH 2" X 4" WOODEN FRAME OR EQUIVALENT AT TOP OF POSTS.
- ② FOR MANUAL INSTALLATIONS THE TRENCH SHALL BE A MINIMUM OF 4" WIDE & 6" DEEP TO BURY AND ANCHOR THE GEOTEXTILE FABRIC. FOLD MATERIAL TO FIT TRENCH AND BACKFILL & COMPACT TRENCH WITH EXCAVATED SOIL.
- ③ WOOD POSTS SHALL BE A MINIMUM SIZE OF 1 1/8" X 1 1/8" OF OAK OR HICKORY.
- ④ SILT FENCE TO EXTEND ACROSS THE TOP OF THE PIPE.
- ⑤ CONSTRUCT SILT FENCE FROM A CONTINUOUS ROLL IF POSSIBLE BY CUTTING LENGTHS TO AVOID JOINTS. IF A JOINT IS NECESSARY USE ONE OF THE FOLLOWING TWO METHODS; A) OVERLAP THE END POSTS AND TWIST, OR ROTATE, AT LEAST 180 DEGREES, B) HOOK THE END OF EACH SILT FENCE LENGTH.

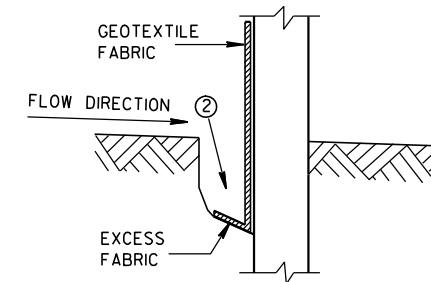

TRENCH DETAIL

NOTE: ADDITIONAL POST DEPTH OR TIE BACKS MAY BE REQUIRED IN UNSTABLE SOILS

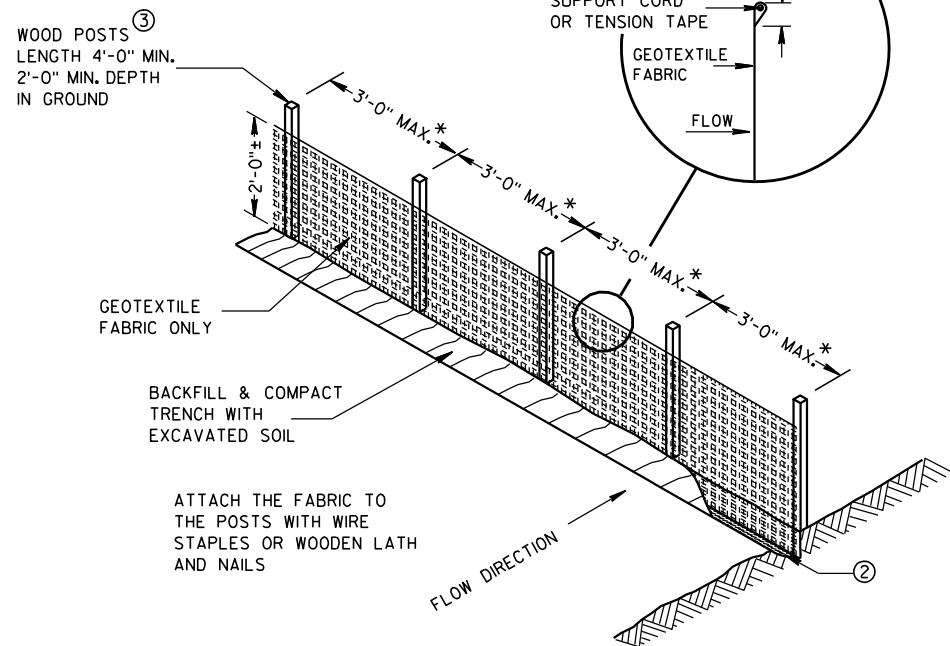

SILT FENCE

\* NOTE: 8'-0" POST SPACING ALLOWED IF A WOVEN GEOTEXTILE FABRIC IS USED.

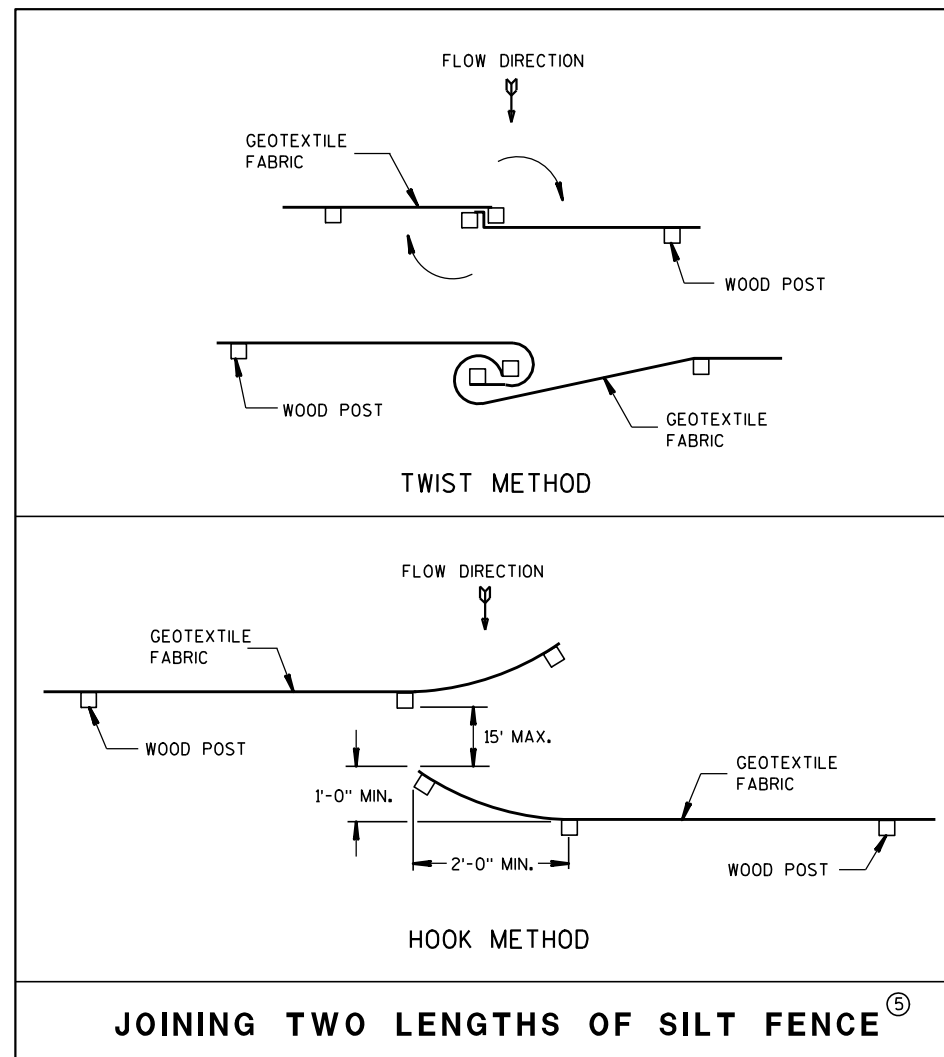

JOINING TWO LENGTHS OF SILT FENCE ⑤

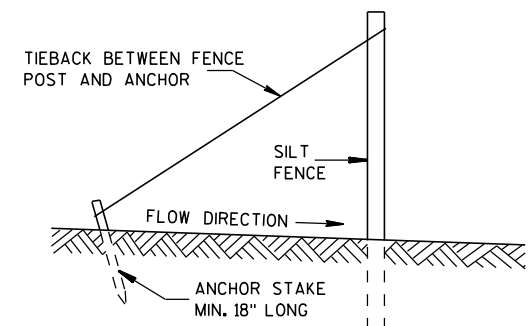

SILT FENCE TIE BACK  
(WHEN REQUIRED BY THE ENGINEER)

**SILT FENCE**

STATE OF WISCONSIN  
DEPARTMENT OF TRANSPORTATION

APPROVED  
4-29-05 /S/ Beth Canestra  
DATE CHIEF ROADWAY DEVELOPMENT ENGINEER  
FHWA

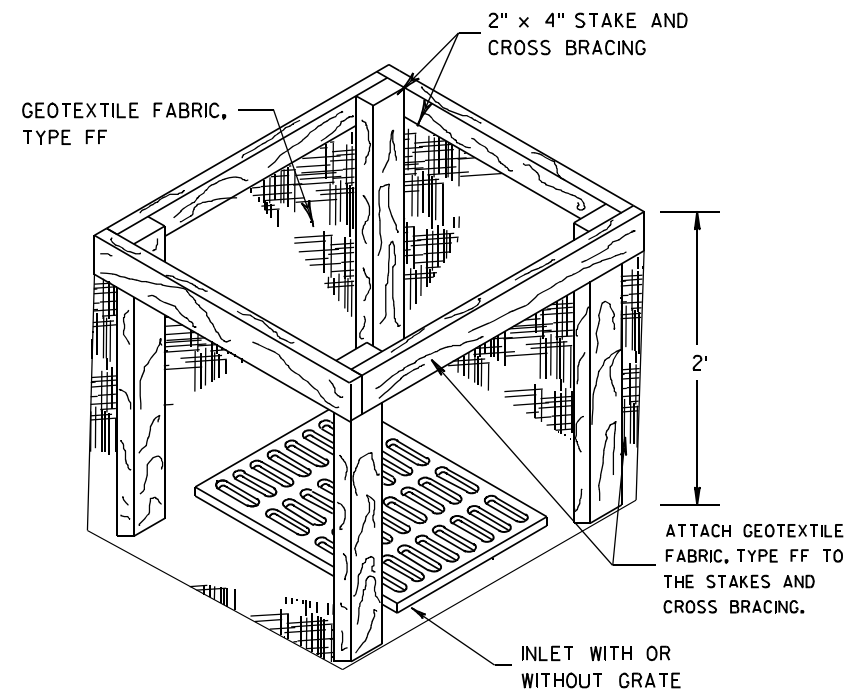
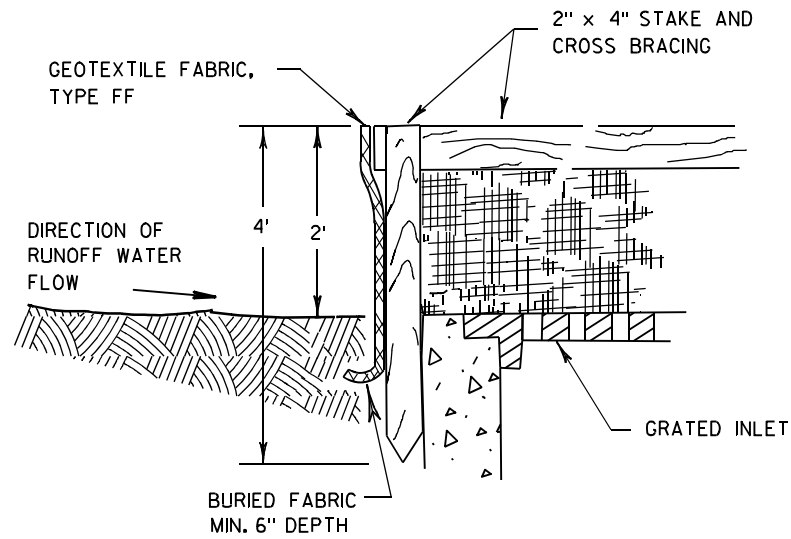

**INLET PROTECTION, TYPE A**

**GENERAL NOTES**

INLET PROTECTION DEVICES SHALL BE MAINTAINED OR REPLACED AT THE DIRECTION OF THE ENGINEER.

MANUFACTURED ALTERNATIVES APPROVED AND LISTED ON THE DEPARTMENT'S EROSION CONTROL PRODUCT ACCEPTABILITY LIST MAY BE SUBSTITUTED.

WHEN REMOVING OR MAINTAINING INLET PROTECTION, CARE SHALL BE TAKEN SO THAT THE SEDIMENT TRAPPED ON THE GEOTEXTILE FABRIC DOES NOT FALL INTO THE INLET. ANY MATERIAL FALLING INTO THE INLET SHALL BE REMOVED IMMEDIATELY.

- ① FINISHED SIZE, INCLUDING FLAP POCKETS WHERE REQUIRED, SHALL EXTEND A MINIMUM OF 10" AROUND THE PERIMETER TO FACILITATE MAINTENANCE OR REMOVAL.
- ② FOR INLET PROTECTION, TYPE C (WITH CURB BOX), AN ADDITIONAL 18" OF FABRIC IS WRAPPED AROUND THE WOOD AND SECURED WITH STAPLES. THE WOOD SHALL NOT BLOCK THE ENTIRE HEIGHT OF THE CURB BOX OPENING.
- ③ FLAP POCKETS SHALL BE LARGE ENOUGH TO ACCEPT WOOD 2X4.

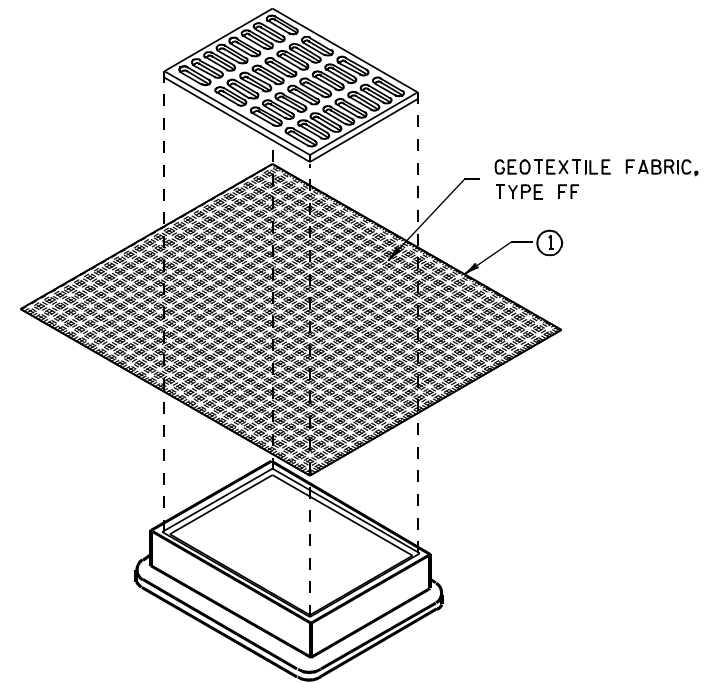

**INLET PROTECTION, TYPE B  
(WITHOUT CURB BOX)**

(CAN BE INSTALLED IN ANY INLET WITHOUT A CURB BOX)

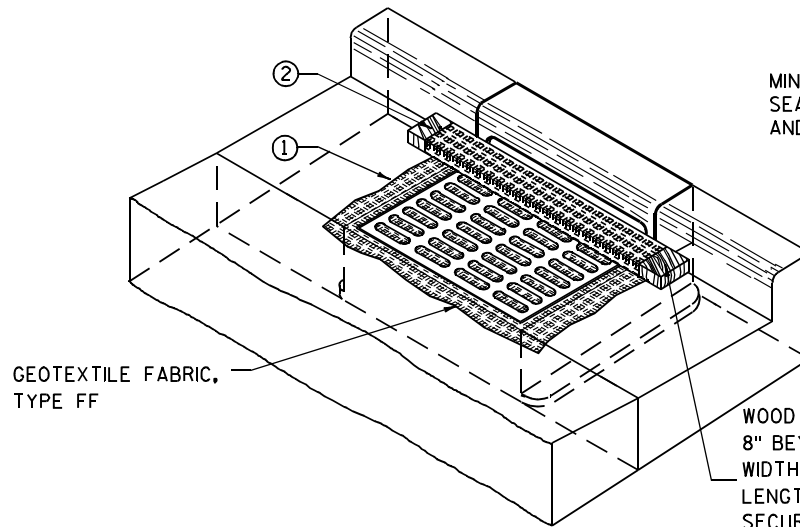

**INLET PROTECTION, TYPE C (WITH CURB BOX)**

**INSTALLATION NOTES**

**TYPE B & C**

TRIM EXCESS FABRIC IN THE FLOW LINE TO WITHIN 3" OF THE GRATE.

THE CONTRACTOR SHALL DEMONSTRATE A METHOD OF MAINTENANCE, USING A SEWN FLAP, HAND HOLDS OR OTHER METHOD TO PREVENT ACCUMULATED SEDIMENT FROM ENTERING THE INLET.

**TYPE D**

DO NOT INSTALL INLET PROTECTION TYPE D IN INLETS SHALLOWER THAN 30", MEASURED FROM THE BOTTOM OF THE INLET TO THE TOP OF THE GRATE.

TRIM EXCESS FABRIC IN THE FLOW LINE TO WITHIN 3" OF THE GRATE.

THE INSTALLED BAG SHALL HAVE A MINIMUM SIDE CLEARANCE, BETWEEN THE INLET WALLS AND THE BAG, MEASURED AT THE BOTTOM OF THE OVERFLOW HOLES, OF 3". WHERE NECESSARY THE CONTRACTOR SHALL CINCH THE BAG, USING PLASTIC ZIP TIES, TO ACHIEVE THE 3" CLEARANCE. THE TIES SHALL BE PLACED AT A MAXIMUM OF 4" FROM THE BOTTOM OF THE BAG.

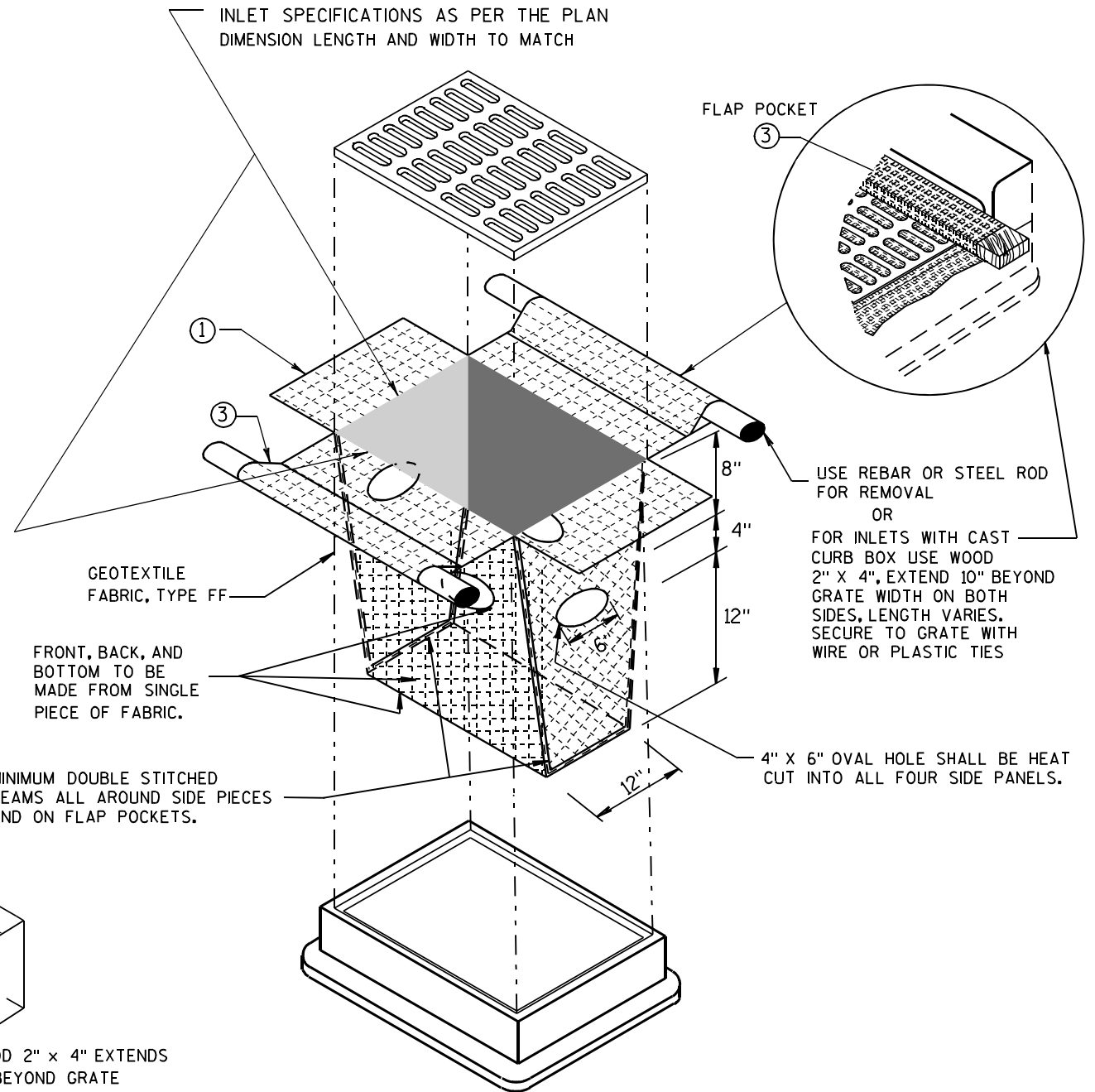

**INLET PROTECTION, TYPE D**

(CAN BE INSTALLED IN ANY INLET TYPE WITH OR WITHOUT A CURB BOX AS PER NOTE ②)

<b>INLET PROTECTION TYPE A, B, C, AND D</b>	
STATE OF WISCONSIN DEPARTMENT OF TRANSPORTATION	
APPROVED 10/16/02 DATE	/S/ Beth Connestra CHIEF ROADWAY DEVELOPMENT ENGINEER
FHWA	

**GENERAL NOTES**

DETAILS OF CONSTRUCTION, MATERIALS AND WORKMANSHIP NOT SHOWN ON THIS DRAWING SHALL CONFORM TO THE PERTINENT REQUIREMENTS OF THE STANDARD SPECIFICATIONS AND THE APPLICABLE SPECIAL PROVISIONS.

TRACKING PAD SHALL BE INSPECTED DAILY. DEFICIENT AREAS SHALL BE REPAIRED OR REPLACED IMMEDIATELY.

TRACKING PAD TO BE REMOVED AFTER CONSTRUCTION IS COMPLETED.

TRACKING PAD SHALL BE THE FULL WIDTH OF THE EGRESS POINT.

SURFACE WATER MUST BE PREVENTED FROM PASSING THROUGH THE TRACKING PAD. FLOWS SHALL BE DIVERTED AWAY, AROUND OR CONVEYED UNDER THE TRACKING PAD.

CULVERT PIPE OR OTHER BMP USED TO DIVERT WATER AWAY, AROUND OR UNDER THE TRACKING PAD SHALL BE DESIGNED TO CONVEY THE 2 YEAR - 24 HOUR EVENT.

THE COST OF ADDITIONAL BMP TO DIVERT WATER ARE INCIDENTAL TO THE TRACKING PAD BID ITEM.

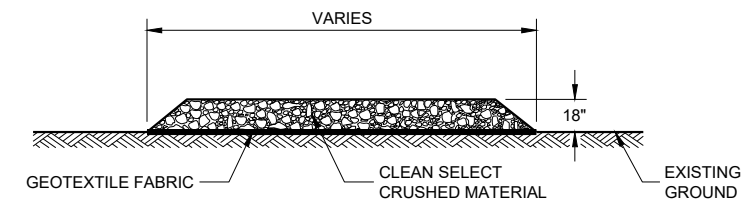
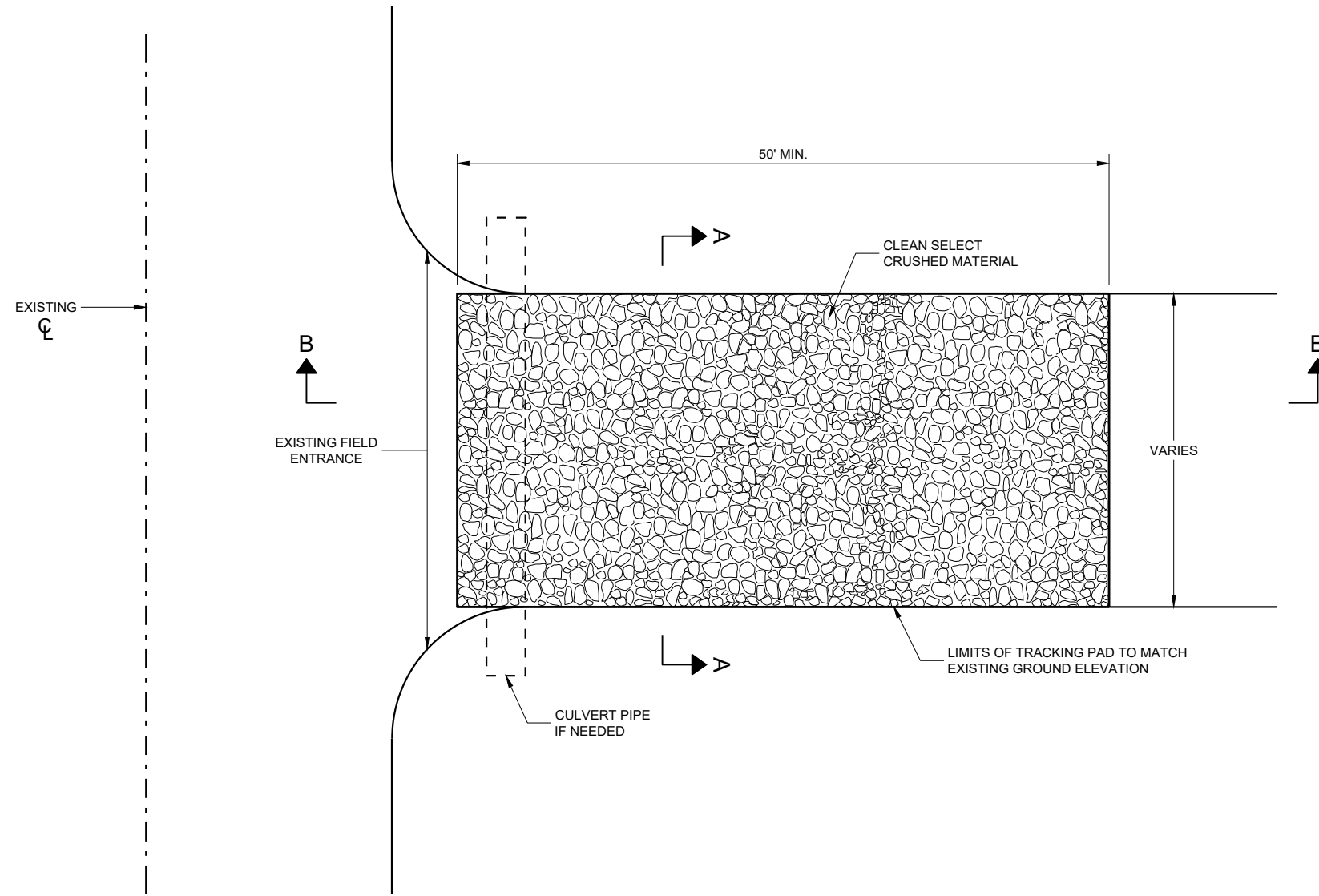

**SECTION A - A**

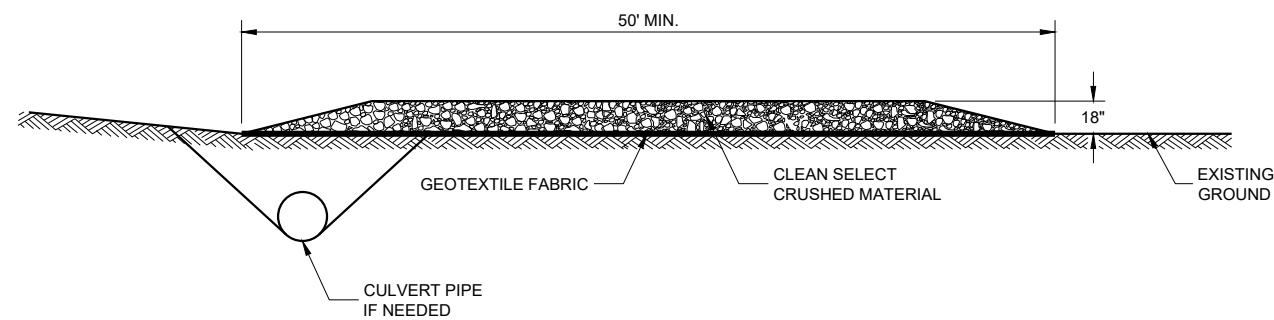

**SECTION B - B**

**TRACKING PAD**

STATE OF WISCONSIN  
DEPARTMENT OF TRANSPORTATION

APPROVED  
3/24/2011 /S/ Jerry H. Zogg  
DATE ROADWAY STANDARDS DEVELOPMENT  
ENGINEER

FHWA

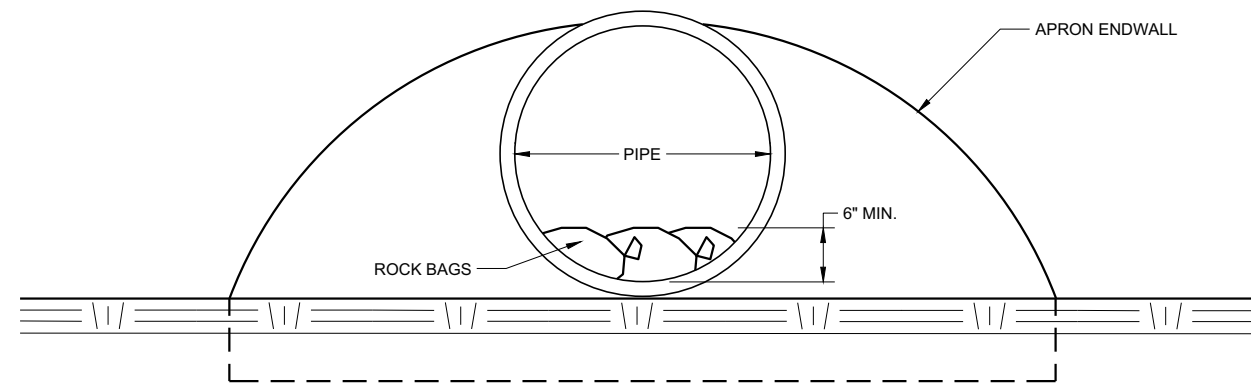

**END VIEW**

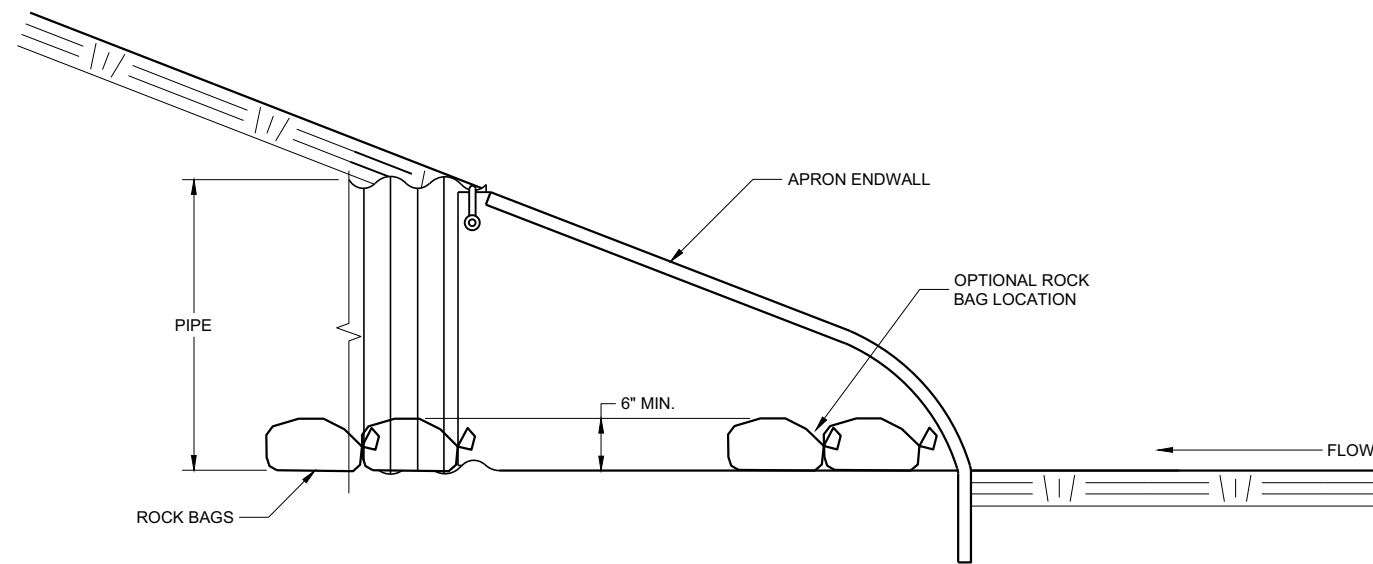

**SIDE VIEW**

**CULVERT PIPE CHECK**  
(INSTALL ON INLET END ONLY)

6

6

SDD 08E15 - 01

SDD 08E15 - 01

<b>CULVERT PIPE CHECK</b>	
STATE OF WISCONSIN DEPARTMENT OF TRANSPORTATION	
APPROVED May 2019 DATE	/S/ Daniel Schave EROSION CONTROL ENGINEER
<small>FHWA</small>	



METAL APRON ENDWALLS											
PIPE DIA. (IN.)	MIN. THICK. (Inches)		DIMENSIONS (Inches)							APPROX. SLOPE	BODY
	STEEL	ALUM.	A (±1")	B (MAX.)	H (±1")	L (±1 1/2")	L1	L2	W (±2")		
12	.064	.060	6	6	6	21	12	17 1/2	24	2 1/2 to 1	1 Pc.
15	.064	.060	7	8	6	26	14	21 3/4	30	2 1/2 to 1	1 Pc.
18	.064	.060	8	10	6	31	15	28 1/4	36	2 1/2 to 1	1 Pc.
21	.064	.060	9	12	6	36	18	29 5/8	42	2 1/2 to 1	1 Pc.
24	.064	.075	10	13	6	41	18	37 1/4	48	2 1/2 to 1	1 Pc.
30	.079	.075	12	16	8	51	18	52 1/4	60	2 1/2 to 1	1 Pc.
36	.079	.105	14	19	9	60	24	59 3/4	72	2 1/2 to 1	2 Pc.
42	.109	.105	16	22	11	69	24	75 5/8	84	2 1/2 to 1	2 Pc.
48	.109	.105	18	27	12	78	24	81	90	2 1/4 to 1	3 Pc.
54	.109	.105	18	30	12	84	30	85 1/2	102	2 1/4 to 1	3 Pc.
60	.109x	.105x	18	33	12	87	—	—	114	2 to 1	3 Pc.
66	.109x	.105x	18	36	12	87	—	—	120	2 to 1	3 Pc.
72	.109x	.105x	18	39	12	87	—	—	126	2 to 1	3 Pc.
78	.109x	.105x	18	42	12	87	—	—	132	1 1/2 to 1	3 Pc.
84	.109x	.105x	18	45	12	87	—	—	138	1 1/2 to 1	3 Pc.
90	.109x	.105x	18	37	12	87	—	—	144	1 1/2 to 1	3 Pc.
96	.109x	.105x	18	35	12	87	—	—	150	1 1/2 to 1	3 Pc.

\* EXCEPT CENTER PANEL SEE GENERAL NOTES

REINFORCED CONCRETE APRON ENDWALLS									
PIPE DIA. (IN.)	DIMENSIONS (Inches)							APPROX. SLOPE	
	T	A	B	C	D	E	G		
12	2	4	24	48 1/8	72 1/8	24	2	3 to 1	
15	2 1/4	6	27	46	73	30	2 1/4	3 to 1	
18	2 1/2	9	27	46	73	36	2 1/2	3 to 1	
21	2 3/4	9	36	37 1/2	73 1/2	42	2 3/4	3 to 1	
24	3	9 1/2	43 1/2	30	73 1/2	48	3	3 to 1	
27	3 1/4	10 1/2	49 1/2	24	73 1/2	54	3 1/4	3 to 1	
30	3 1/2	12	54	19 3/4	73 1/2	60	3 1/2	3 to 1	
36	4	15	63	34 3/4	97 3/4	72	4	3 to 1	
42	4 1/2	21	63	35	98	78	4 1/2	3 to 1	
48	5	24	72	26	98	84	5	3 to 1	
54	5 1/2	27	65	33 1/4-35	98 1/4-100	90	5 1/2	2 1/2 to 1	
60	6	30-35	60	39	99	96	5	2 to 1	
66	6 1/2	24-30	72-78	21-27	99	102	5 1/2	2 to 1	
72	7	24-36	78	21	99	108	6	2 to 1	
78	7 1/2	24-36	78	21	99	114	6 1/2	2 to 1	
84	8	36	90 1/2	21	111 1/2	120	6 1/2	1 1/2 to 1	
90	8 1/2	41	87 1/2	24	111 1/2	132	6 1/2	1 1/2 to 1	

\* MINIMUM  
\*\* MAXIMUM

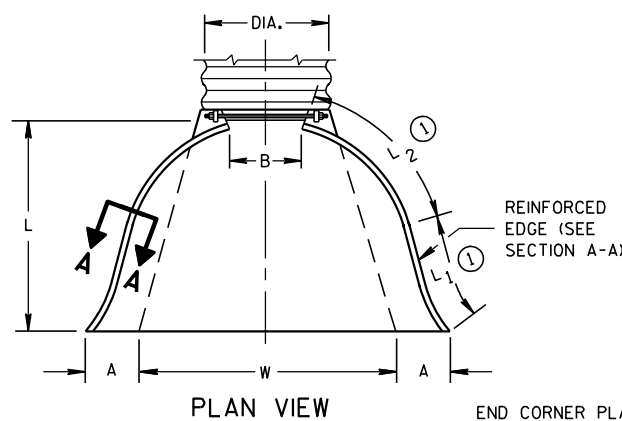

END CORNER PLATES MAY BE FASTENED TO APRON PROPER BY BOLTS, RIVETS, OR RESISTANCE SPOT WELDS WHICH WILL HOLD THE SURFACES TIGHTLY TOGETHER

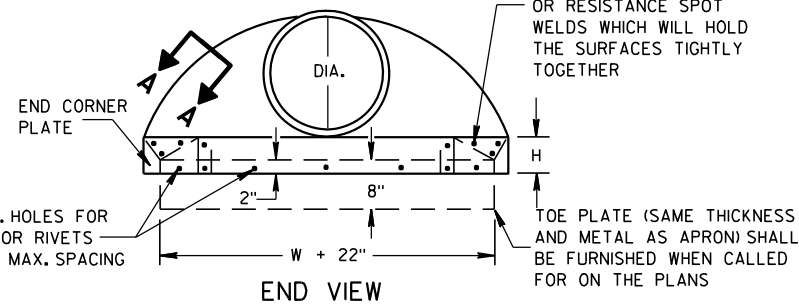

SIDE ELEVATION  
METAL ENDWALLS

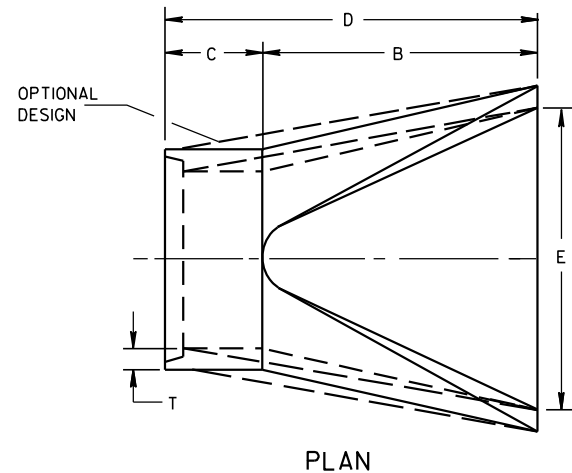

PLAN

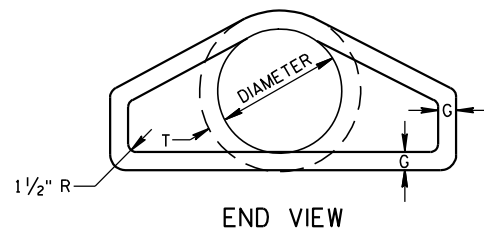

END VIEW

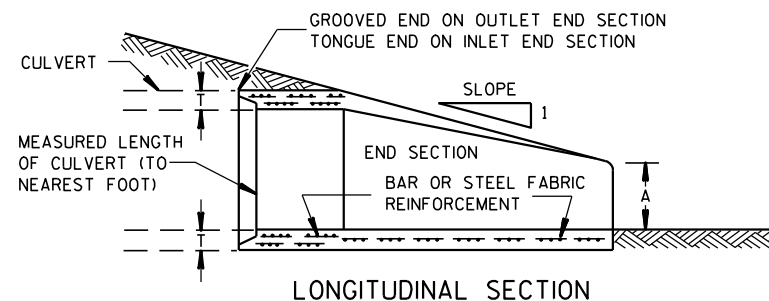

LONGITUDINAL SECTION  
CONCRETE ENDWALLS

1" WIDE, 12 GA. (0.109" THICK) GALVANIZED STRAP WITH STANDARD 6" X 1/2" BAND BOLT AND NUT

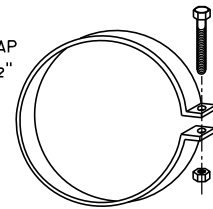

ALTERNATE FOR TYPE 1 CONNECTION  
END SECTION CONNECTOR STRAP

THREADED 3/16" DIA. ROD AROUND CULVERT & THROUGH TANK TYPE CONNECTOR LUG OR ALTERNATE CONNECTOR STRAP (SEE DETAIL)

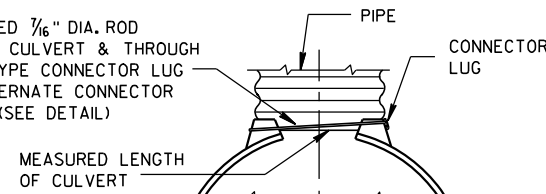

TYPE 1  
FOR 12" THRU 24" CORR. PIPE

THREADED 3/16" DIA. ROD OVER TOP OF APRON, SIDE LUGS TO BE RIVETED TO APRON



TYPE 2  
FOR 30" THRU 96" CORR. PIPE

MEASURED LENGTH OF CULVERT

TYPE 3  
FOR 42" THRU 96" CORR. PIPE

DIMPLED OR CORRUGATED COUPLING BAND

TYPE 5  
ALTERNATE FOR:  
ALL SIZES CORRUGATED CIRCULAR PIPE

NOTE: DIMPLED BAND FITS OVER OUTSIDE OF ENDWALL, AND CORRUGATED BAND FITS INSIDE ENDWALL. DIMPLED BAND MAY BE USED WITH HELICALLY CORRUGATED PIPE.

FOR CIRCUMFERENTIALLY CORRUGATED PIPE USE ENDWALL CONNECTION DETAILS 1, 2, 3 OR 5 AS APPLICABLE.

FOR HELICALLY CORRUGATED PIPE USE ENDWALL CONNECTION DETAILS 1, 2 OR 5.

FOR HELICALLY CORRUGATED PIPES WITH TWO CIRCUMFERENTIAL CORRUGATIONS AT EACH END USE ENDWALL CONNECTION DETAILS 1, 2 OR 3.

CONNECTION DETAILS

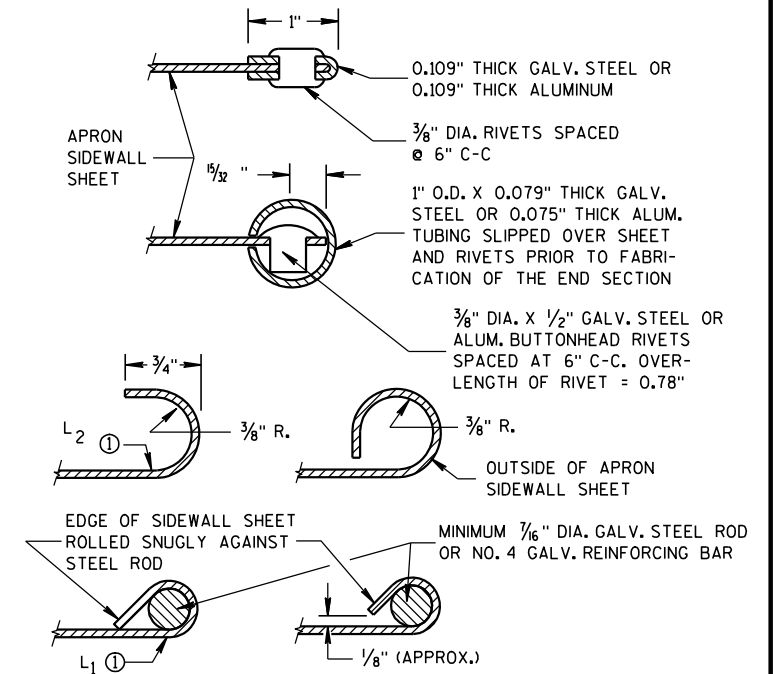

SECTION A-A

GENERAL NOTES

DETAILS OF CONSTRUCTION, MATERIALS AND WORKMANSHIP NOT SHOWN ON THIS DRAWING SHALL CONFORM TO THE PERTINENT REQUIREMENTS OF THE STANDARD SPECIFICATIONS AND THE APPLICABLE SPECIAL PROVISIONS.

CONCRETE CULVERT ENDWALLS MAY NOT BE USED WITH GALVANIZED STEEL OR ALUMINUM CULVERT PIPE OR VICE VERSA. GALVANIZED STEEL OR ALUMINUM ENDWALLS SHALL NORMALLY BE INSTALLED ON CULVERT PIPE OF THE SAME METAL.

ALL THREE PIECE STEEL APRON ENDWALLS FOR 60" DIAMETER PIPE AND LARGER SHALL HAVE 0.109" SIDES AND 0.138" CENTER PANELS. ALL THREE PIECE ALUMINUM APRON ENDWALLS FOR 60" DIAMETER PIPE AND LARGER SHALL HAVE 0.105" SIDES AND 0.134" CENTER PANELS. THE WIDTH OF CENTER PANELS SHALL BE GREATER THAN 20 PERCENT OF THE PIPE PERIMETER.

LAP SEAMS SHALL BE TIGHTLY JOINED BY GALVANIZED RIVETS OR BOLTS FOR STEEL UNITS AND ALUMINUM RIVETS AND BOLTS FOR ALUMINUM UNITS. FOR THE 60" THROUGH 96" DIAMETER APRON ENDWALL SIZES, THE REINFORCED EDGES AND CENTER PANEL SEAMS SHALL BE FURTHER REINFORCED WITH GALVANIZED STEEL OR ALUMINUM STIFFENER ANGLES. THE ANGLES SHALL BE ATTACHED BY GALVANIZED NUTS AND BOLTS FOR STEEL UNITS AND ALUMINUM NUTS AND BOLTS FOR ALUMINUM UNITS.

WHERE TWO OR MORE PIPES WITH APRON ENDWALLS ARE LAID ADJACENT TO EACH OTHER, THEY SHALL BE SEPARATED BY A DISTANCE SUFFICIENT TO PROVIDE A MINIMUM CLEARANCE OF 6 INCHES BETWEEN APRON ENDWALLS.

① FOR PIPE SIZES UP TO 60" DIAMETER, A 180° ROLLED EDGE MAY BE USED INSTEAD OF STEEL ROD REINFORCEMENT. SEE SECTION A-A.

APRON ENDWALLS FOR  
CULVERT PIPE

STATE OF WISCONSIN  
DEPARTMENT OF TRANSPORTATION

APPROVED  
11/30/94 DATE /S/ Rory L. Rhinesmith  
DATE CHIEF ROADWAY DEVELOPMENT ENGINEER  
FHWA

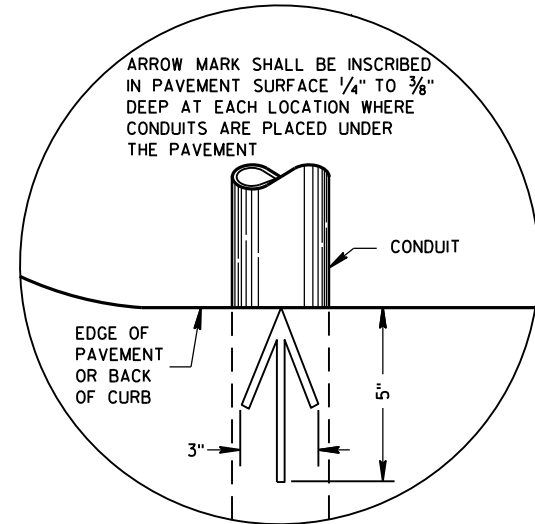

**PLAN VIEW  
ARROW MARK**

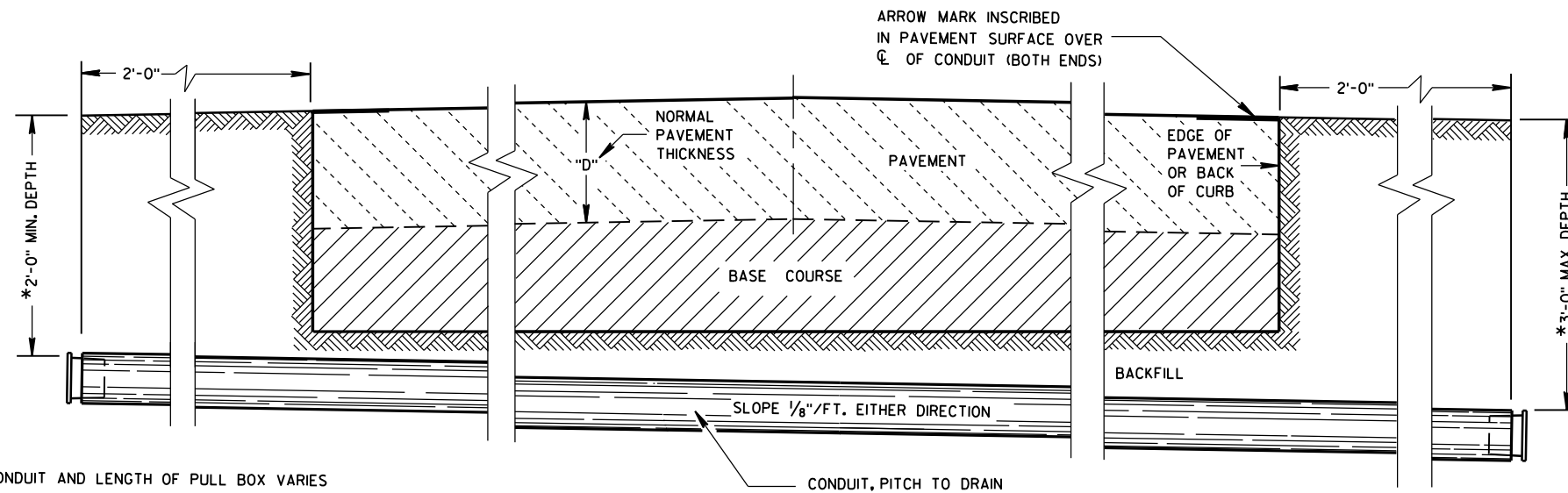

**SIDE ELEVATION  
DETAIL FOR CONDUIT UNDER PAVED HIGHWAYS**

\*DEPTH OF CONDUIT AND LENGTH OF PULL BOX VARIES WITH HEIGHT OF CURB USED. ALSO SEE PULL BOX S.D.D. 9B4

**GENERAL NOTES**

DETAILS OF CONSTRUCTION, MATERIALS AND WORKMANSHIP NOT SHOWN ON THIS DRAWING SHALL CONFORM TO THE PERTINENT REQUIREMENTS OF THE CONTRACT.

METALLIC (STANDARD SPECIFICATION 652.2.2) OR NONMETALLIC (STANDARD SPECIFICATION 652.2.3) CONDUIT SHALL BE FURNISHED AND PLACED AS SHOWN.

DEPTH OF CONDUIT INSTALLED BELOW THE TRAVELED WAY SHALL BE 24 INCHES MINIMUM AND 36 INCHES MAXIMUM.

DEPTH OF CONDUIT INSTALLED THAT IS NOT BELOW THE TRAVELED WAY SHALL BE 18 INCHES MINIMUM AND 36 INCHES MAXIMUM.

ANY EXCEPTION TO THE MAXIMUM DEPTH SHALL BE ONLY WITH THE WRITTEN APPROVAL OF THE ENGINEER.

THE TRENCH SHALL NOT BE BACKFILLED PRIOR TO INSPECTION OF THE CONDUIT.

ALL METALLIC CONDUIT RACEWAY ENDS SHALL BE REAMED AND THREADED.

ALL METALLIC CONDUIT IN WHICH WIRE OR CABLE IS TO BE INSTALLED SHALL BE BUSHED WITH APPROVED THREADED BUSHINGS BEFORE INSTALLATION OF THE WIRE OR CABLE.

ALL METALLIC CONDUITS IN WHICH WIRE OR CABLE IS NOT TO BE INSTALLED SHALL BE CAPPED WITH THREADED PROTECTIVE CAPS, AS APPROVED BY THE ENGINEER.

ALL NONMETALLIC CONDUIT SHALL BE CAPPED OR PLUGGED IMMEDIATELY AFTER INSTALLATION AND SHALL REMAIN CAPPED OR PLUGGED UNTIL WIRE/CABLES ARE INSTALLED.

NONMETALLIC CONDUITS IN WHICH WIRE OR CABLE IS NOT BEING INSTALLED SHALL REMAIN CAPPED OR PLUGGED.

BENDING OF PVC ELECTRICAL CONDUIT SHALL BE ACCOMPLISHED BY USING A BLANKET OR EMERSON TYPE TANK DESIGNED FOR THE PURPOSE OF BENDING PVC ELECTRICAL CONDUIT.

ALL CUT ENDS SHALL BE TRIMMED INSIDE AND OUTSIDE TO REMOVE ALL ROUGH EDGES ON NONMETALLIC CONDUIT. (SEE NEC 347.5)

WHEN REQUIRED TO CONNECT NONMETALLIC CONDUIT TO METALLIC CONDUIT, ONLY U.L. LISTED ADAPTER FITTINGS SHALL BE USED.

PRIOR TO CONDUIT ACCEPTANCE, CONDUIT CAPS OR PLUGS SHALL BE REMOVED, AND THE CAPS, PLUGS AND CONDUIT ENDS SHALL BE THOROUGHLY CLEANED AND THEN THE CAPS OR PLUGS REINSTALLED TO ENSURE THAT THE CAPS OR PLUGS CAN BE EASILY REMOVED IN THE FUTURE.

ALL CONDUIT BEING FURNISHED AND INSTALLED SHALL HAVE THE U.L. LABEL FIRMLY ATTACHED.

CONDUIT RUNS SHALL BE THE SAME SIZE OF CONDUIT FROM ONE END TO THE OTHER (FROM PULL BOX TO PULL BOX-OR-JUNCTION BOX TO JUNCTION BOX-OR-BASE TO BASE, ETC.).

TRACER WIRE SHALL BE INSTALLED AS STATED IN THE STANDARD SPECIFICATION, ITEM 652.3.1.1.

ALL CONDUIT RUNS SHALL BE STRAIGHT (WITHOUT BENDS) FROM PULL BOX TO PULL BOX, PULL BOX TO BASE AND BASE TO BASE AS SHOWN ON THE PLANS.

<b>CONDUIT</b>	
STATE OF WISCONSIN DEPARTMENT OF TRANSPORTATION	
APPROVED March, 2017 DATE	/S/ Ahmet Demirbilek STATE ELECTRICAL ENGINEER
FHWA	

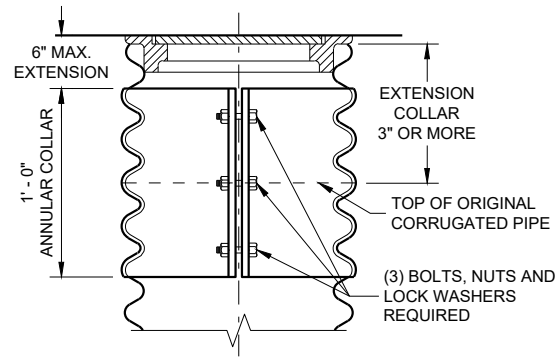

**CORRUGATED PIPE EXTENDER**

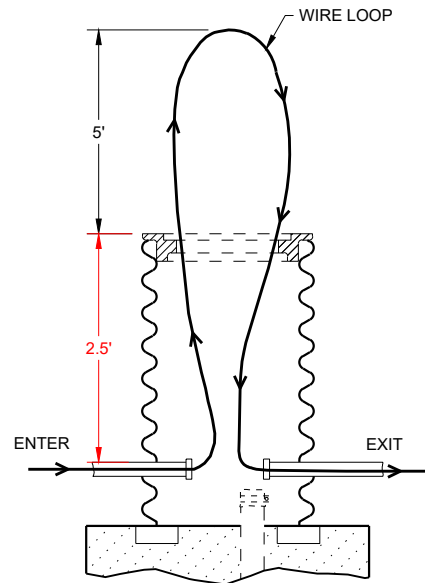

**MEASUREMENT DETAIL FOR WIRE/CABLE IN THE PULL BOX**

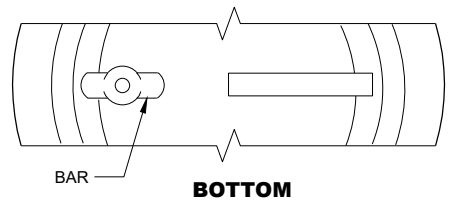

**ALTERNATE COVER (LOCKING)  
TIGHTENING BAR TYPE**

**GENERAL NOTES**

DETAILS OF CONSTRUCTION, MATERIALS AND WORKMANSHIP NOT SHOWN ON THIS DRAWING SHALL CONFORM TO THE PERTINENT REQUIREMENTS OF THE CONTRACT.

ALL FRAMES AND COVERS SHALL BE HEAVY DUTY TYPE, SUITABLE FOR VEHICULAR TRAFFIC LOADS.

PULL BOXES LOCATED IN THE ROADWAYS SHALL HAVE LOCKING COVERS.

ENTRANCE HOLES INTO PULL BOXES SHALL BE CUT WITH A CIRCULAR HOLE SAW OR HYDRAULIC CONDUIT PUNCH. HOLE SIZE SHALL BE THE OUTSIDE DIAMETER OF THE CONDUIT THAT IS TO FIT IN THE OPENING PLUS NO MORE THAN 1/4".

THE CONTRACTOR SHALL NOT INSTALL WIRE IN ANY PULL BOX UNTIL ITS INSTALLATION HAS BEEN INSPECTED AND ACCEPTED BY THE ENGINEER.

GROUNDING LUGS (MECHANICAL CONNECTORS) SHALL BE U.L. LISTED AND APPROVED FOR USE WITH COPPER WIRE.

ALL METALLIC CONDUIT IN WHICH WIRE AND/OR CABLE IS TO BE INSTALLED, SHALL BE BUSHED BEFORE INSTALLATION OF THE WIRE AND/OR CABLE.

WHEN PULL BOXES ARE INSTALLED FOR FUTURE USE, DO NOT INSTALL THE EQUIPMENT GROUNDING LUG. THE EQUIPMENT GROUNDING LUG, THE EQUIPMENT GROUNDING ELECTRODE AND THE EQUIPMENT GROUNDING CONDUCTOR SHALL BE REQUIRED AND INSTALLED UNDER A FUTURE WIRING CONTRACT.

**TABLE OF NOMINAL DIMENSIONS AND WEIGHTS**

DIMENSION IN INCHES	CORRUGATED STEEL PIPE									
	PIPE DIAMETER (INSIDE)	12	12	12	18	18	18	24	24	24
PIPE DIAMETER (INSIDE)	A	12	12	12	18	18	18	24	24	24
PIPE LENGTH**	B	24	30	36	24	30	36	36	42	48
WALL THICKNESS	C	0.064	0.064	0.064	0.064	0.064	0.064	0.064	0.064	0.064
COVER	D	10 1/4	10 1/4	10 1/4	16 1/4	16 1/4	16 1/4	22 1/4	22 1/4	22 1/4
FRAME	E	14 1/2	14 1/2	14 1/2	20 1/2	20 1/2	20 1/2	26 1/2	26 1/2	26 1/2
FRAME	F	8 1/2	8 1/2	8 1/2	14 1/2	14 1/2	14 1/2	20 1/2	20 1/2	20 1/2
FRAME	G	11 1/2	11 1/2	11 1/2	17 1/2	17 1/2	17 1/2	23 1/2	23 1/2	23 1/2
WEIGHT IN POUNDS*										
FRAME AND COVER		60	60	60	110	110	110	155	155	155

\* THE ACTUAL WEIGHT OF THE MANHOLE FRAME AND COVER MAY VARY WITHIN 5 PERCENT PLUS OR MINUS OF THE WEIGHTS SHOWN.

\*\* NORMALLY USED LENGTHS. THE PROJECT ENGINEER SHALL DETERMINE IF PIPE LENGTHS, OTHER THAN THOSE SPECIFIED, SHALL BE USED, TO A MAXIMUM OF 48" (CONTINUOUS LENGTH, NON-SPLICED). THE ADDITIONAL LENGTH SHALL BE INCIDENTAL TO THE PULL BOX BID PRICE.

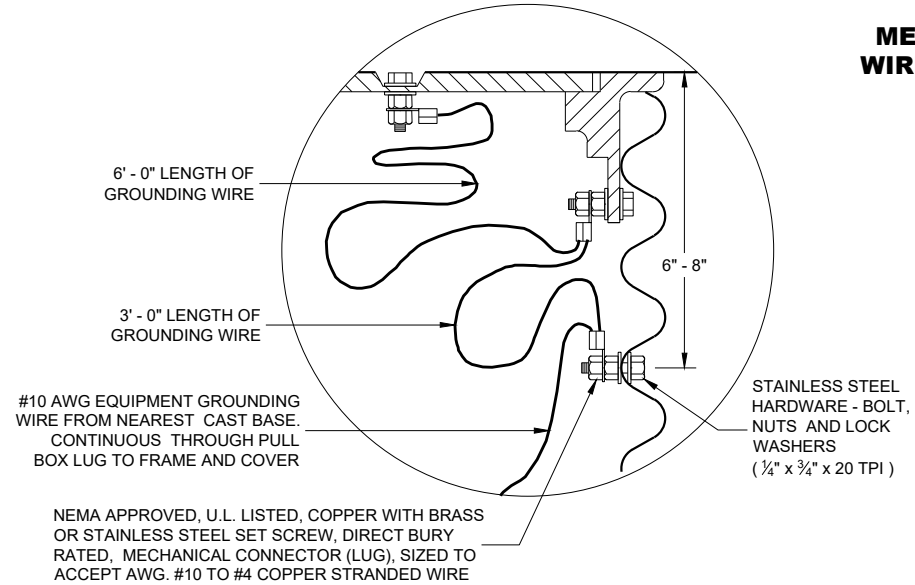

**EQUIPMENT GROUNDING LUG AND LOCATION IN STEEL PULL BOXES**

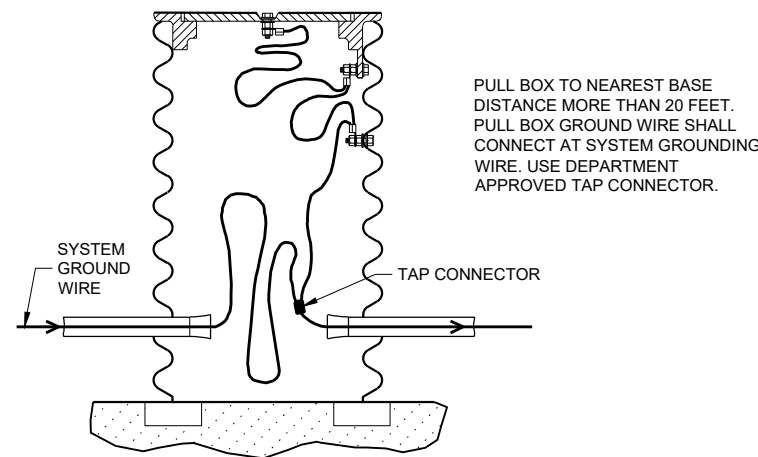

**EQUIPMENT GROUNDING LUG AND LOCATION IN STEEL PULL BOXES**

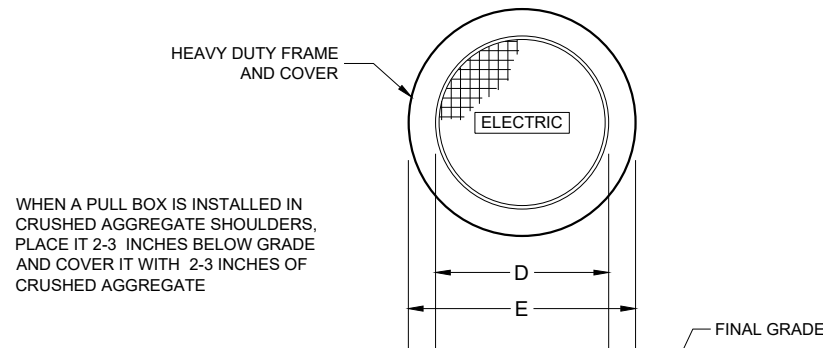

WHEN A PULL BOX IS INSTALLED IN CRUSHED AGGREGATE SHOULDERS, PLACE IT 2-3 INCHES BELOW GRADE AND COVER IT WITH 2-3 INCHES OF CRUSHED AGGREGATE

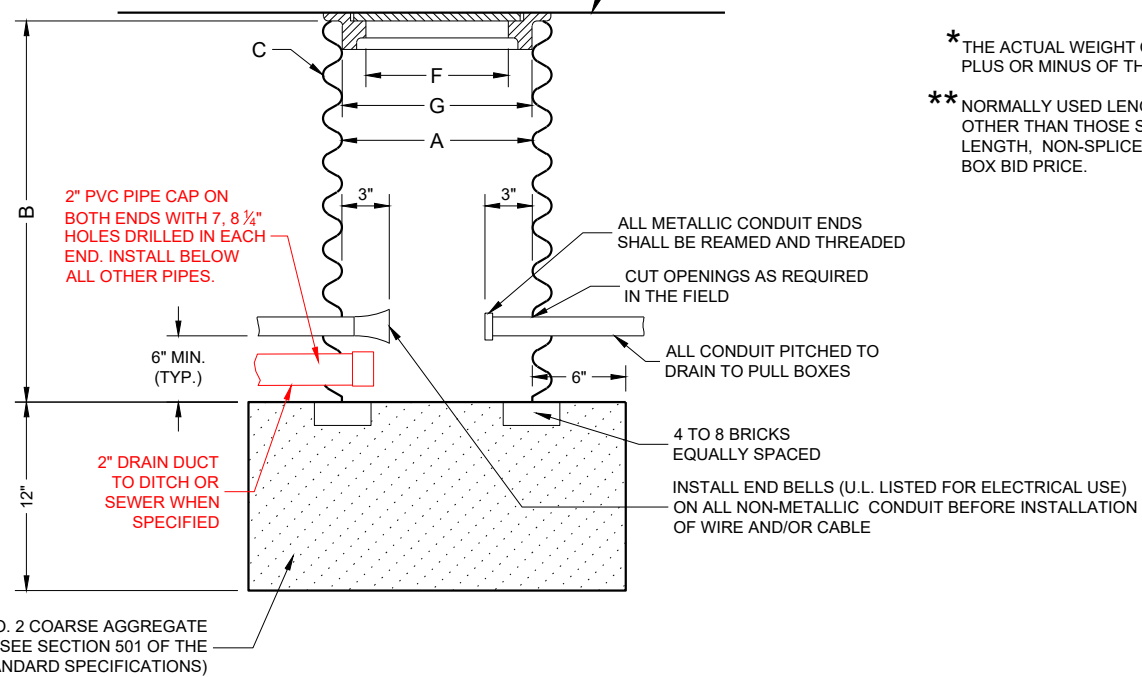

**PULL BOX**

**PULL BOX**

STATE OF WISCONSIN  
DEPARTMENT OF TRANSPORTATION

APPROVED  
May 2022 /S/ Ahmet Demirbilek  
DATE STATE ELECTRICAL ENGINEER

FHWA

FORM DEPTH SHALL BE NO MORE THAN 6" BELOW GRADE ON THE LOWER SIDE OF BASE

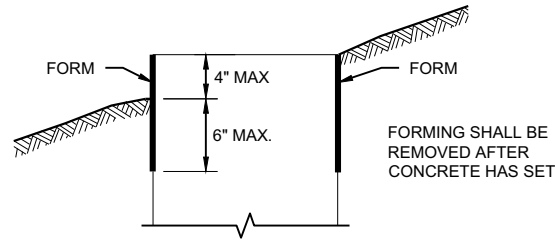

**FORMING DETAIL**

QUANTITY REQUIREMENTS	CONCRETE BASE TYPE		
	1	2	5 & 6
APPROX. CUBIC YARDS OF CONCRETE	0.40	0.57	0.40
LBS. OF HOOP BAR STEEL	NONE	23	16
LBS. OF VERTICAL BAR STEEL	NONE	60	18

**GENERAL NOTES**

DETAILS OF CONSTRUCTION, MATERIALS AND WORKMANSHIP NOT SHOWN ON THIS DRAWING SHALL CONFORM TO THE PERTINENT REQUIREMENTS OF THE CONTRACT.

BASES SHALL BE EXCAVATED BY USE OF A CIRCULAR AUGER.

TOP SURFACES OF CONCRETE BASES SHALL BE TROWEL FINISHED SMOOTH AND LEVEL.

CONDUIT SIZES AND LOCATIONS SHALL BE SHOWN ON THE PLANS

THE FINAL OR TERMINATING CONCRETE BASE IN A CONDUIT RUN SHALL HAVE A 6" EXIT STUB INSTALLED FOR FUTURE CABLING USE. THE EXIT STUB SHALL BE SIZED AS USED THROUGHOUT THE CONDUIT RUN AS SHOWN AT THE ENTRANCE OF THE BASE.

ENDS OF CONDUIT INSTALLED BELOW GRADE FOR FUTURE USE SHALL BE CAPPED IF METALLIC OR PLUGGED IF NON-METALLIC.

MINIMUM BENDING RADIUS OF CONDUIT IS EQUAL TO 6X THE DIAMETER.

CONDUIT HEIGHT ABOVE CONCRETE BASES SHALL BE 1 INCH. ALL METALLIC CONDUIT ENDS SHALL BE REAMED AND THREADED.

ALL CONDUIT ENDS AT THE TOP OF CONCRETE BASES SHALL BE CAPPED IF METALLIC OR PLUGGED IF NON-METALLIC IMMEDIATELY AFTER PLACEMENT AND BEFORE CONCRETE IS POURED. CONDUITS IN WHICH WIRE OR CABLE IS NOT INSTALLED SHALL REMAIN CAPPED OR PLUGGED.

BELL ENDS SHALL BE INSTALLED ON ALL PVC CONDUIT EXPOSED AT THE TOP OF CONCRETE BASES BEFORE INSTALLATION.

WHEN REQUIRED TO CONNECT NON-METALLIC CONDUIT TO METALLIC CONDUIT, ONLY ADAPTER FITTINGS, U.L. LISTED FOR ELECTRICAL USE, SHALL BE USED.

IF A BASE REQUIRES A DEEP FORM BECAUSE OF LOOSE DIRT OR FILL, THE FORM SHALL BE REMOVED BEFORE BACKFILLING AROUND THE BASE. BACKFILL SHALL BE TAMPED TIGHT AGAINST THE BARE CONCRETE BASE IN LAYERS OF 1 FOOT OR LESS.

A NO. 4 AWG STRANDED COPPER EQUIPMENT GROUNDING CONDUCTOR SHALL BE EXOTHERMICALLY WELDED TO THE EQUIPMENT GROUNDING ELECTRODE (GROUND ROD) FOR TYPE 2, TYPE 5 AND TYPE 6 BASES.

THE EQUIPMENT GROUNDING CONDUCTOR SHALL BE FURNISHED AND INSTALLED TO ENTER ALL BASE TYPES THROUGH A 1 INCH CONDUIT INSTALLED FOR GROUNDING PURPOSES, LEAVING A 4 FOOT COIL OF WIRE ABOVE THE CONCRETE BASE. THE EQUIPMENT GROUNDING CONDUCTOR SHALL BE NEATLY COILED AND THE COILS TIED TOGETHER.

ANCHOR RODS SHALL BE THREADED 12" IN LENGTH ON EACH END OF THE ROD. ANCHOR RODS SHALL BE MANUFACTURED IN ACCORDANCE WITH SECTION 654.2.1 OF THE STANDARD SPECIFICATIONS.

WASHERS AND LOCK WASHERS ARE REQUIRED ON ALL ANCHOR RODS.

WHEN ANCHOR RODS USING THE ALTERNATE "L" BEND ARE FURNISHED, THE 4 INCH "L" BEND SHALL BE IN ADDITION TO THE SPECIFIED ANCHOR ROD BAR LENGTH. THE "L" BEND SHALL NOT BE THREADED.

ANCHOR RODS SHALL BE INSTALLED WITH MISALIGNMENTS OF LESS THAN 1:40 FROM VERTICAL.

WELDING OF THE ANCHOR RODS TO THE CAGE IS UNACCEPTABLE. TIE WIRES SHALL BE USED.

BAR STEEL REINFORCEMENT SHALL BE COATED WITH POWDERED EPOXY RESIN IN ACCORDANCE WITH SECTION 505 OF THE STANDARD SPECIFICATIONS (LATEST EDITION).

- ① THE MINIMUM DEPTH OF CONDUIT EXITING THE CONCRETE BASE AND INSTALLED BELOW THE TRAVELED WAY SHALL BE 24 INCHES. THE MINIMUM DEPTH OF CONDUIT EXITING THE CONCRETE BASE THAT IS NOT INSTALLED BELOW THE TRAVELED WAY SHALL BE 18 INCHES. THE MAXIMUM DEPTH OF ALL CONDUIT SHALL BE 36 INCHES EXCEPT WITH WRITTEN APPROVAL OF THE ENGINEER.
- ② (4) 1" DIA. X 3' - 6" ANCHOR RODS.
- ③ (4) 1" DIA. X 5' - 0" ANCHOR RODS.
- ④ (6) NO. 6 X 6' - 8" BAR STEEL REINFORCEMENT.
- ⑤ (7) NO. 4 X 5' - 1" BAR STEEL REINFORCEMENT @ 1' - 0" C - C.
- ⑥ (4) 1" DIA. X 3' - 6" ANCHOR RODS.
- ⑦ (6) NO. 4 X 4' - 8" BAR STEEL REINFORCEMENT.
- ⑧ (5) NO. 4 X 5' - 1" BAR STEEL REINFORCEMENT @ 1' - 0" C - C.
- ⑨ EXOTHERMIC CONNECTION TO EQUIPMENT GROUNDING CONDUCTOR
- ⑩ 5/8" DIA. X 8' - 0" COPPERCLAD EQUIPMENT GROUNDING ELECTRODE REQUIRED
- ⑪ ANY ANCHOR ROD PROJECTION SHORTER THAN 2 3/4" OR LONGER THAN 3 1/4" SHALL REQUIRE THE BASE TO BE REMOVED AND REPLACED AT THE CONTRACTORS EXPENSE.
- ⑫ FOR NON - BREAKAWAY INSTALLATIONS, 4 1/2" ± ANCHOR ROD PROJECTION WITH THE USE OF LEVELING NUTS. RODENT SCREEN REQUIRED.

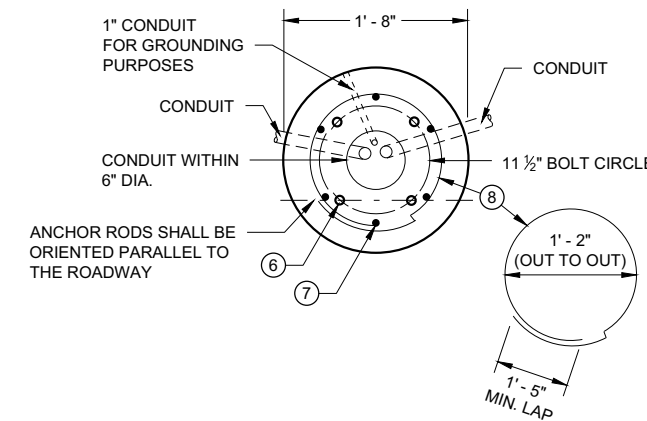
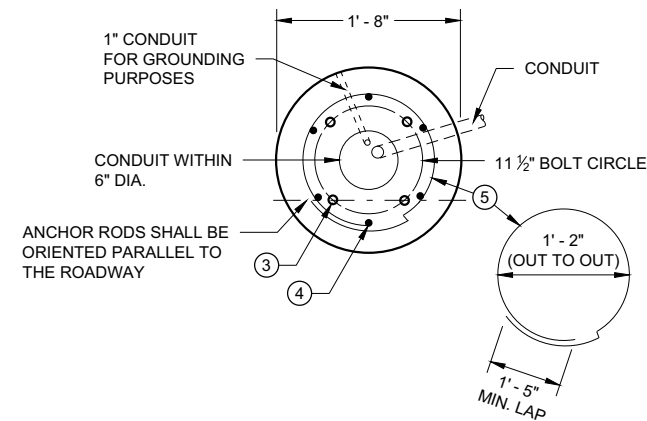
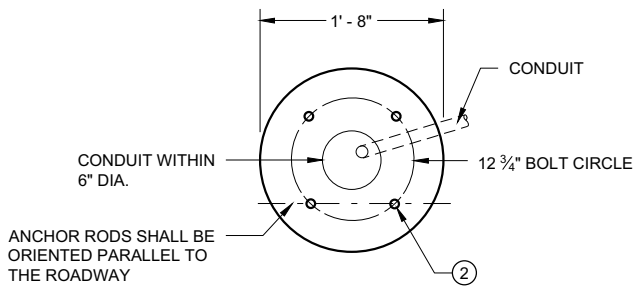

**HALF SECTION IN UNPAVED AREA**

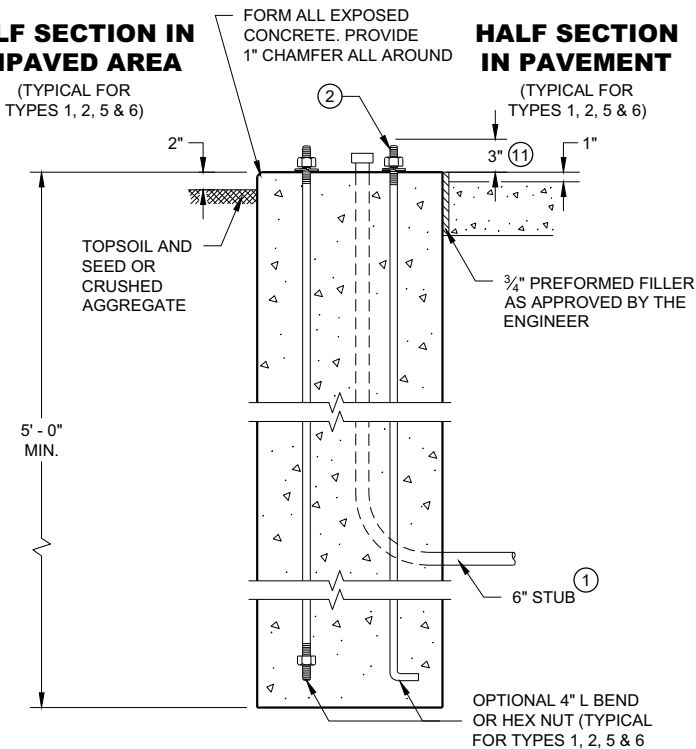

**TYPE 1**

**HALF SECTION IN PAVEMENT**

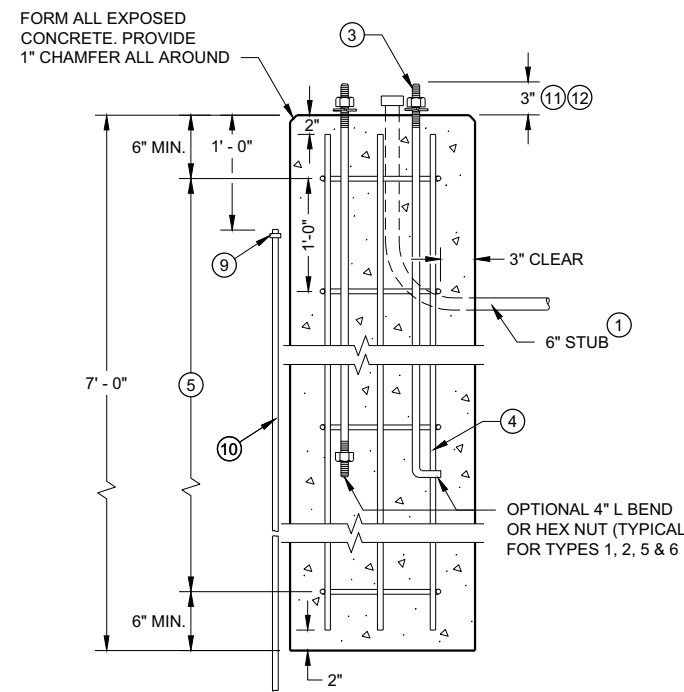

**TYPE 2**

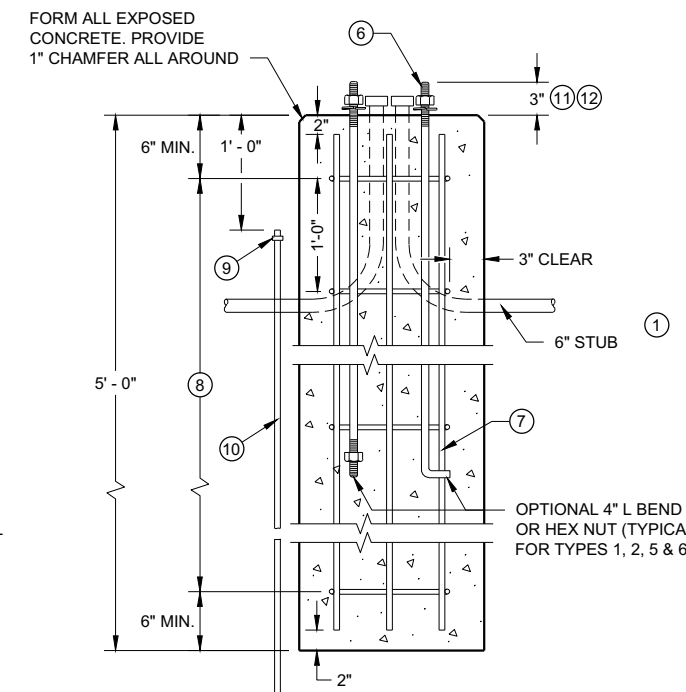

**TYPE 5 & 6**

**CONCRETE BASES**

**CONCRETE BASES  
TYPES 1, 2, 5, & 6**

STATE OF WISCONSIN  
DEPARTMENT OF TRANSPORTATION

APPROVED  
May 2019 /S/ Ahmet Demirelek  
DATE STATE ELECTRICAL ENGINEER

FHWA

**GENERAL NOTES**

DETAILS OF CONSTRUCTION, MATERIALS AND WORKMANSHIP NOT SHOWN ON THIS DRAWING SHALL CONFORM TO THE PERTINENT REQUIREMENTS OF THE CONTRACT.

FOUR (4) BOLTS SHALL BE FURNISHED WITH EACH TRANSFORMER BASE. BOLTS SHALL BE 1" DIAMETER, 4" IN LENGTH, WITH WASHERS, LOCK WASHERS AND NUTS. BOLTS, NUTS AND WASHERS SHALL BE MANUFACTURED IN ACCORDANCE WITH SECTION 531.2.2 OF THE STANDARD SPECIFICATIONS.

LEVELING SHIMS, IF NEEDED, SHALL BE DESIGNED FOR THE PURPOSE AND USED UNDER CAST BASES WHEN PLUMBING POLES OR STANDARDS DURING INSTALLATION. THE USE OF WASHERS IN LIEU OF PROPER LEVELING SHIMS IS NOT ACCEPTABLE.

SHIM LENGTH SHALL BE LONG ENOUGH TO COMPLETELY COVER THE AREA UNDER THE LENGTH AND WIDTH OF THE BASE MOUNTING FLANGE.

DOUBLE NUTTING IS NOT ACCEPTABLE FOR LEVELING OR MOUNTING PURPOSES.

A NEMA APPROVED, U.L. LISTED, COPPER WITH BRASS OR STAINLESS STEEL SET SCREW, DIRECT BURY RATED, MECHANICAL CONNECTOR (LUG), SIZED TO ACCEPT AWG. #10 TO #4 COPPER STRANDED WIRE SHALL BE FURNISHED AND INSTALLED IN THE PEDESTAL AND TRANSFORMER BASES.

THE MECHANICAL CONNECTOR SHALL BE INSTALLED USING A 1/4" - 20 (TPI) STAINLESS STEEL HEX HEAD BOLT OF SUFFICIENT LENGTH TO FIRMLY ATTACH THE LUG TO THE BASE.

SHOULD THE MANNER OF ATTACHMENT OF THE LUG REQUIRE WASHERS, HEX NUTS, LOCK WASHER - THEY SHALL BE STAINLESS STEEL AS IS THE BOLT. THE MANNER OF ATTACHMENT SHALL NOT BLOCK ACCESSIBILITY TO WIRE PLACEMENT IN THE CONNECTOR.

PEDESTAL BASE COLLAR THREADING SHALL BE TAPERED AND IN ACCORDANCE WITH NATIONAL PIPE THREADING DIMENSIONS.

BASE COLLAR THREADING SHALL EXTEND INTO THE BASE COLLAR WITH SUFFICIENT DEPTH TO ACCEPT THE INSTALLATION OF TRAFFIC SIGNAL STANDARDS TO A DEPTH OF 1/2", THEN TIGHTENING TO A POINT OF BEING IMMOVABLE.

THE ACCESS DOOR SHALL BE OF THE SAME MATERIAL AS THE BASE.

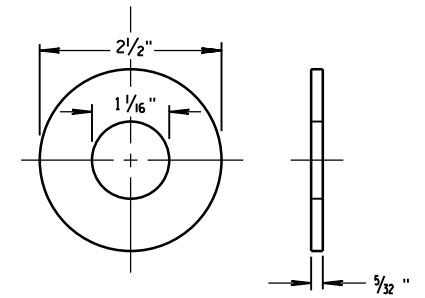
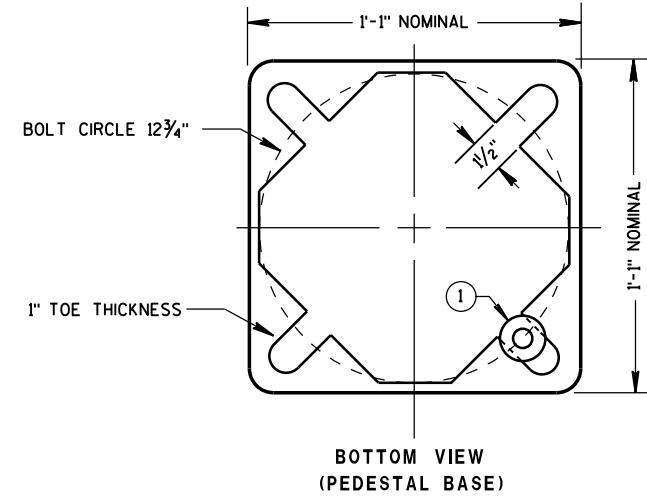
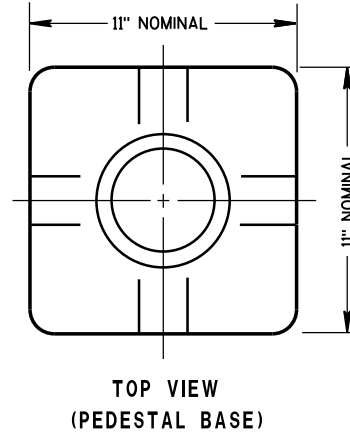
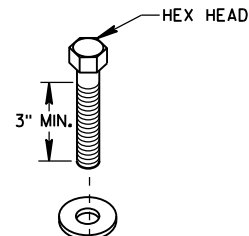

ZINC COATED STEEL WASHER TO BE PROVIDED BY THE CONTRACTOR  
**PEDESTAL BASE WASHER** ①

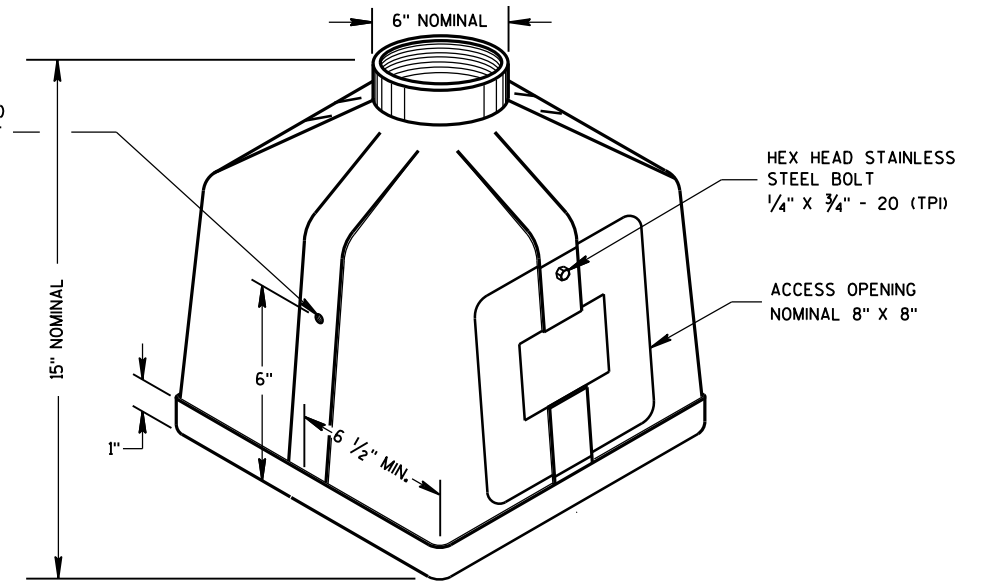
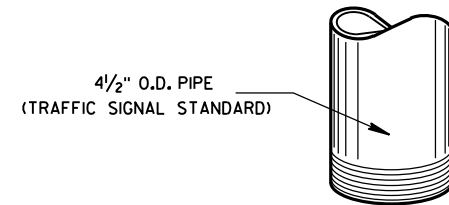

**ISOMETRIC VIEW PEDESTAL BASE**

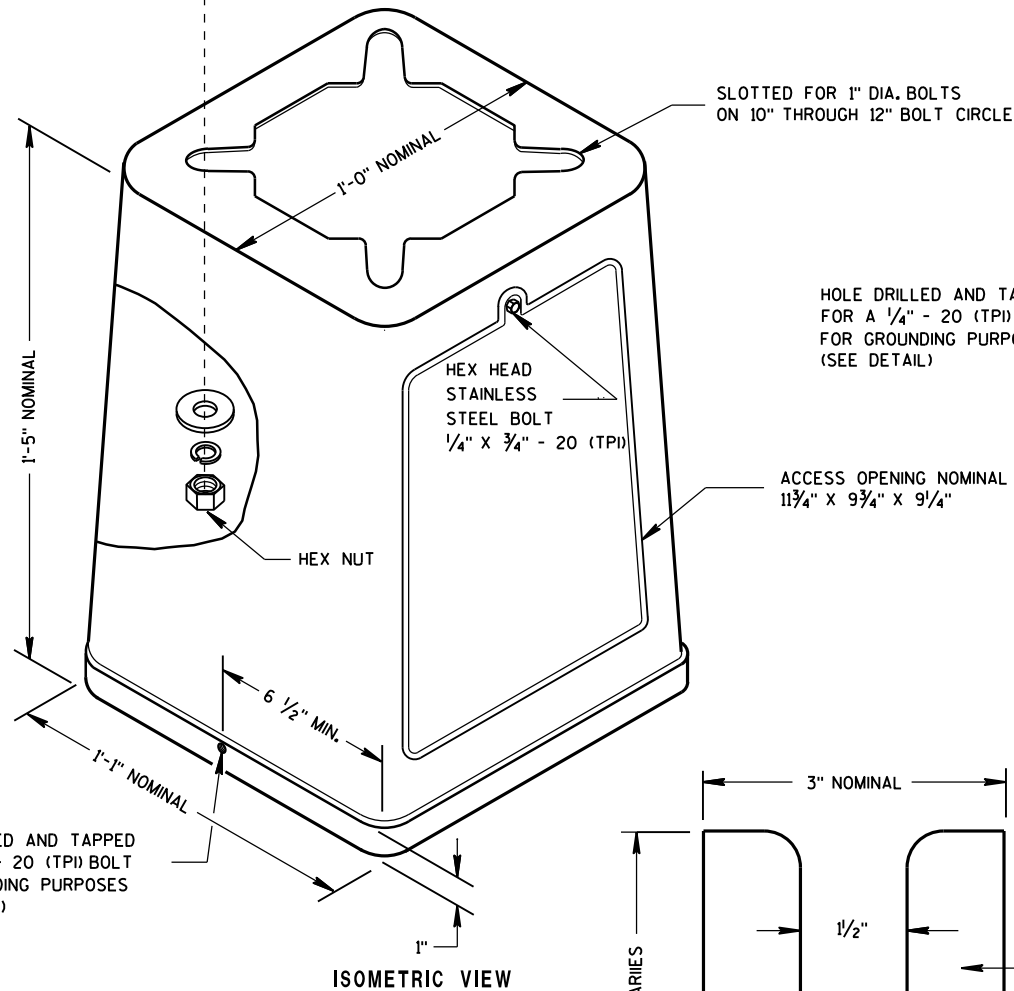

HOLE DRILLED AND TAPPED FOR A 1/4" - 20 (TPI) BOLT FOR GROUNDING PURPOSES (SEE DETAIL)

HOLE DRILLED AND TAPPED FOR A 1/4" - 20 (TPI) BOLT FOR GROUNDING PURPOSES (SEE DETAIL)

ACCESS OPENING NOMINAL 11 3/4" X 9 3/4" X 9 1/4"

**ISOMETRIC VIEW**

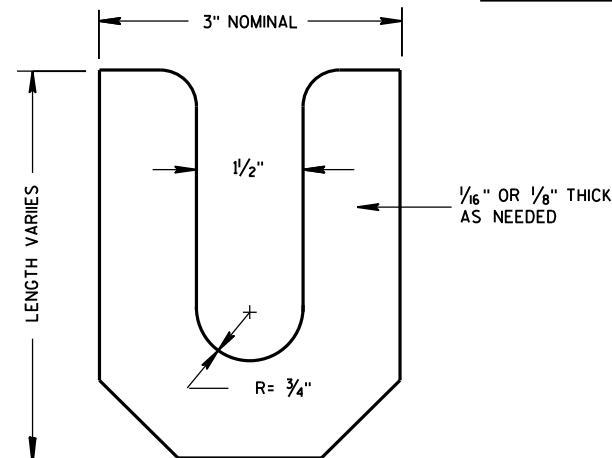

**LEVELING SHIM**

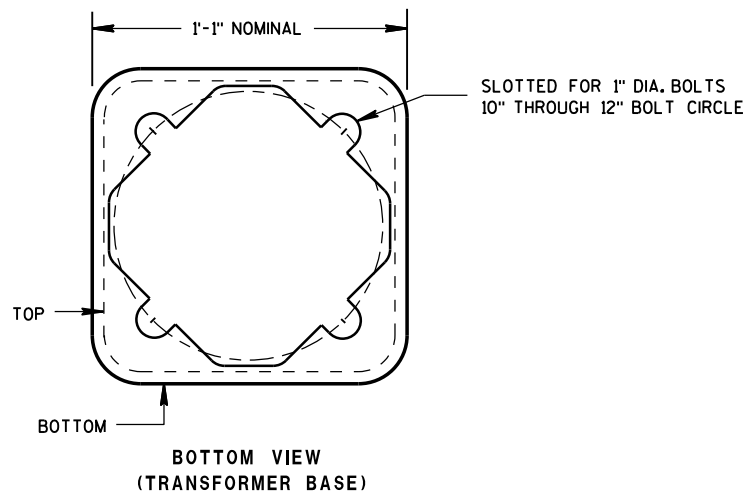

**BOTTOM VIEW (TRANSFORMER BASE)**

**TRANSFORMER BASE**  
INTENDED FOR USE WITH TYPE 2, 3, 4, 5 & 6 POLES

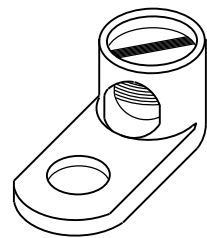

**TYPICAL MECHANICAL CONNECTOR LUG**  
TO BE FURNISHED WITH EACH BASE

<b>TRANSFORMER/PEDESTAL BASES</b>	
STATE OF WISCONSIN DEPARTMENT OF TRANSPORTATION	
APPROVED Sept. 2014 DATE	/S/ Ahmet Demirbilek STATE ELECTRICAL ENGINEER
FHWA	

6

6

S.D.D. 9 C 3-4

S.D.D. 9 C 3-4

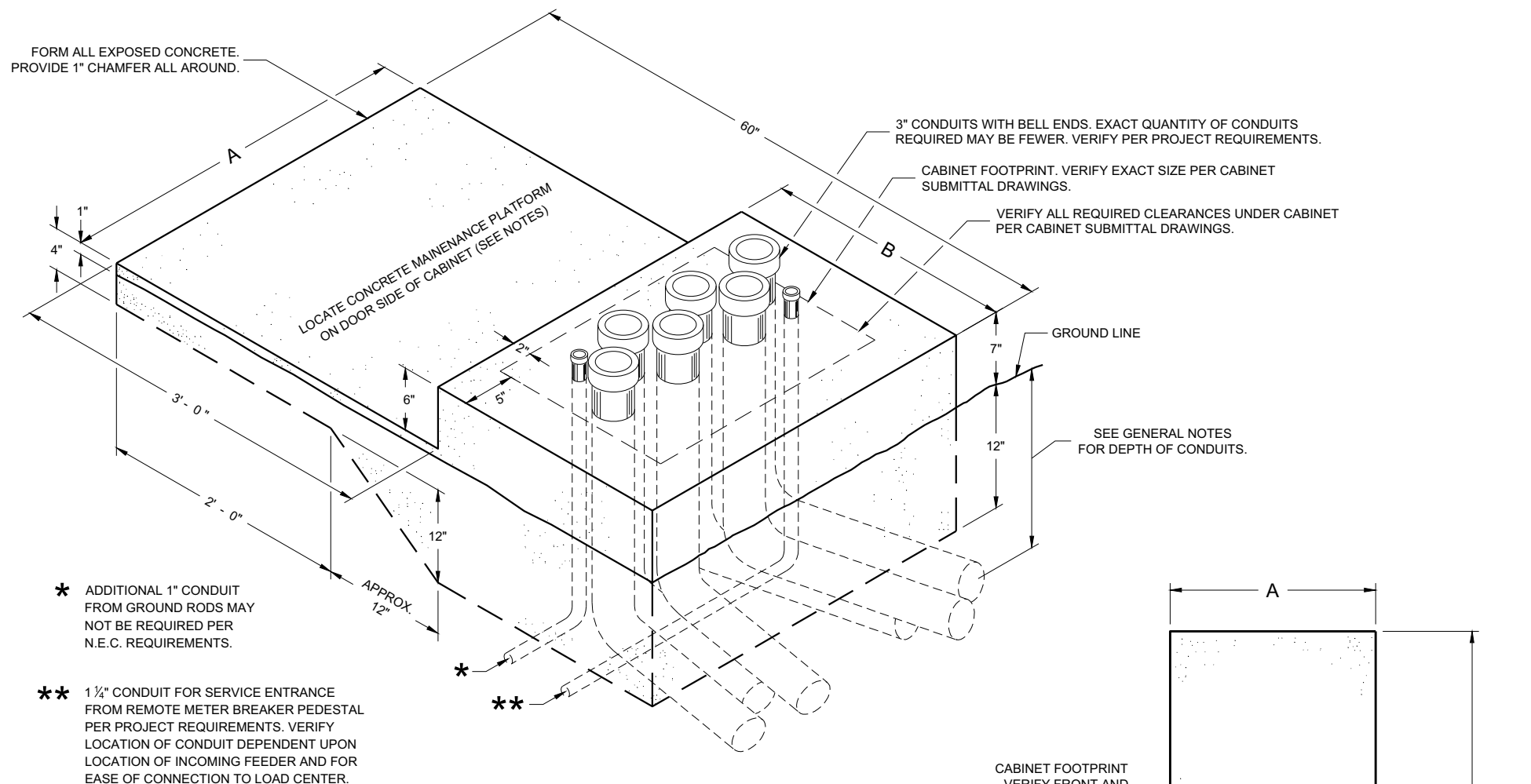

**ISOMETRIC VIEW  
CONCRETE CONTROL CABINET BASE, TYPE L**  
(C.Y. CONCRETE = APPROX. 0.4)

**GENERAL NOTES**

- DETAILS OF CONSTRUCTION, MATERIALS AND WORKMANSHIP NOT SHOWN ON THIS DRAWING SHALL CONFORM TO THE PERTINENT REQUIREMENTS OF THE CONTRACT.
- INSTALL FOUR STAINLESS STEEL APPROVED CONCRETE MASONRY ANCHORS TO ANCHOR THE CABINET BASES. THE ANCHORS SHALL BE LOCATED AS DIRECTED BY THE ENGINEER TO PROPERLY ANCHOR THE CONTROL CABINET TO THE BASE.
- WHEN REQUIRED TO CONNECT NON - METALLIC CONDUIT TO METALLIC CONDUIT, ONLY ADAPTER FITTINGS, U. L. LISTED FOR ELECTRICAL USE, SHALL BE USED.
- CONDUIT HEIGHT ABOVE THE CONCRETE BASE SHALL BE 1 INCH.
- DEPTH OF CONDUIT INSTALLED BELOW THE TRAVELED WAY SHALL BE 24 INCHES MINIMUM AND 36 INCHES MAXIMUM.
- DEPTH OF CONDUIT INSTALLED THAT IS NOT BELOW THE TRAVELED WAY SHALL BE 18 INCHES MINIMUM AND 36 INCHES MAXIMUM.
- ANY EXCEPTION TO THE MAXIMUM DEPTH SHALL BE ONLY WITH THE WRITTEN APPROVAL OF THE ENGINEER.
- LOCATIONS SHALL BE AS SHOWN ON THE PLANS UNLESS DETERMINED BY THE ENGINEER IN THE FIELD.
- CONTROL CABINET BASE TOP SURFACE SHALL BE TROWEL FINISHED SMOOTH AND LEVEL.
- MAINTENANCE PLATFORM SHALL BE FLOAT OR BROOM FINISHED AND LEVEL.
- MAINTENANCE PLATFORMS ARE NOT REQUIRED WHEN THE SURROUNDING AREA IS PAVED.
- MINIMUM BENDING RADIUS OF CONDUIT EQUALS 6 TIMES THE DIAMETER.
- ALL METALLIC CONDUIT ENDS SHALL BE REAMED AND THREADED.
- CAP ALL BELOW GRADE METALLIC CONDUIT ENDS IN WHICH WIRE OR CABLE IS NOT BEING INSTALLED.
- PLUG ALL BELOW GRADE NON - METALLIC CONDUIT ENDS IN WHICH WIRE OR CABLE IS NOT BEING INSTALLED.
- ALL CONDUIT ENDS AT THE TOP OF CONCRETE BASES SHALL BE CAPPED IF METALLIC OR PLUGGED IF NON - METALLIC IMMEDIATELY AFTER PLACEMENT AND BEFORE CONCRETE IS POURED. CONDUITS IN WHICH WIRE OR CABLE IS NOT BEING INSTALLED SHALL REMAIN CAPPED OR PLUGGED.
- CONCRETE FORM DEPTH BELOW FINISHED GRADE SHALL BE 6 INCHES MAXIMUM. CONCRETE FORMS SHALL BE REMOVED AFTER CONCRETE HAS SET.
- CONDUIT EXITING THE CONCRETE BASE SHALL TERMINATE IN PULL BOXES AS SHOWN ON THE PLANS.
- CONCRETE FORM DEPTH BELOW FINISHED GRADE SHALL BE 6 INCH MAXIMUM. CONCRETE FORMS SHALL BE REMOVED AFTER CONCRETE HAS SET.
- BELL ENDS SHALL BE INSTALLED ON ALL PVC CONDUIT EXPOSED AT THE TOP OF THE CONCRETE BASE BEFORE INSTALLATION OF CABLE OR WIRE.

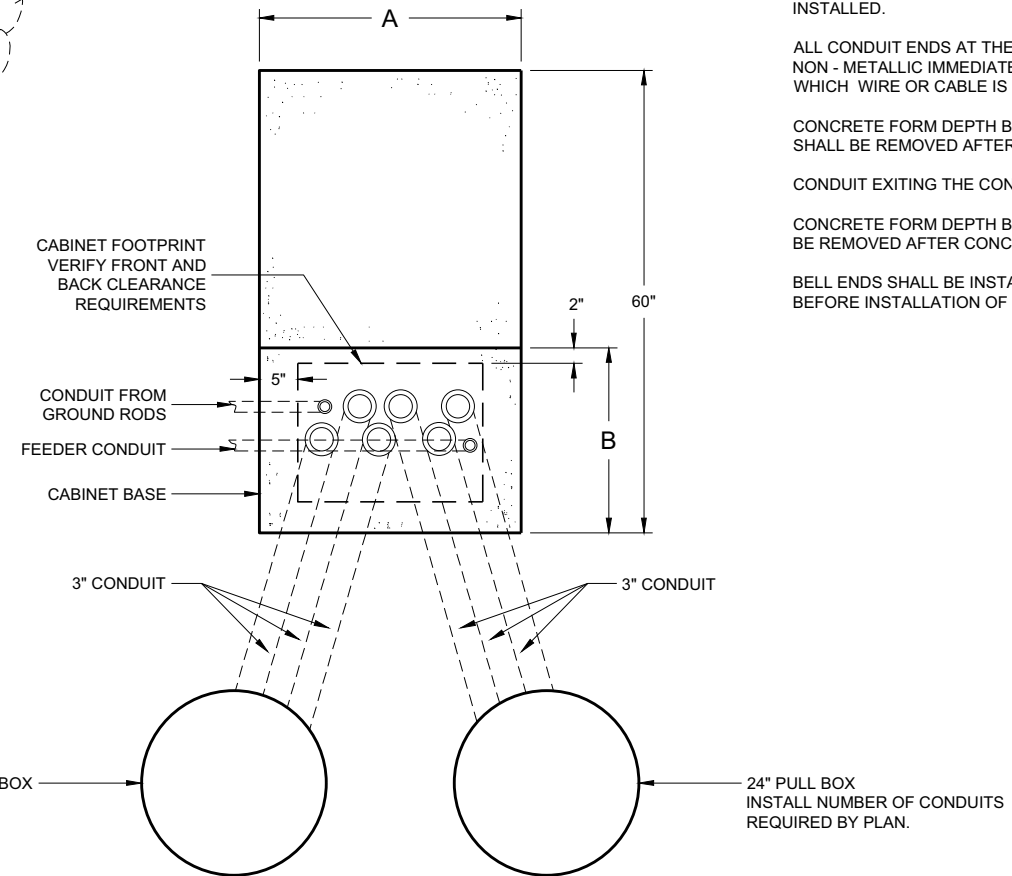

**PLAN VIEW  
CONCRETE CONTROL CABINET BASE, TYPE L**

CONCRETE BASE TYPE	CABINET WIDTH	DIMENSIONS		MAXIMUM 3" CONDUITS
		A	B	
L24	24"	34"	24"	4
L30	30"	40"	24"	6

**CONCRETE CONTROL  
CABINET BASE, TYPE L**

STATE OF WISCONSIN  
DEPARTMENT OF TRANSPORTATION

APPROVED  
November 2018 /S/ Ahmet Demirbilek  
DATE STATE ELECTRICAL ENGINEER

FHWA

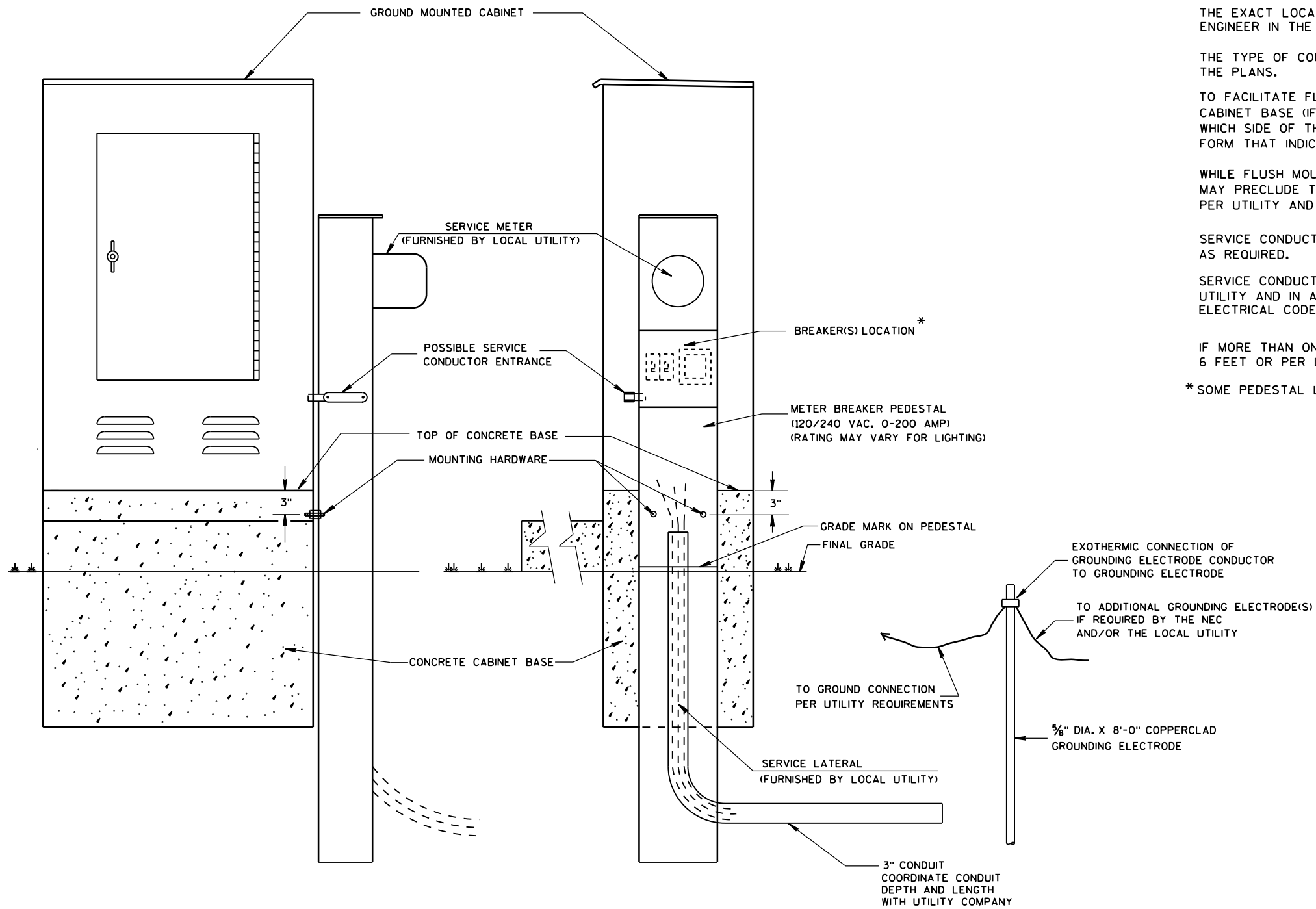

TYPICAL CABINET SERVICE INSTALLATION

GENERAL NOTES

DETAILS OF CONSTRUCTION, MATERIALS AND WORKMANSHIP NOT SHOWN ON THIS DRAWING SHALL CONFORM TO THE PERTINENT REQUIREMENTS OF THE CONTRACT.

THE EXACT LOCATION OF THE METER BREAKER PEDESTAL SHALL BE DETERMINED BY THE ENGINEER IN THE FIELD.

THE TYPE OF CONCRETE CABINET BASE TO BE INSTALLED SHALL BE AS CALLED FOR IN THE PLANS.

TO FACILITATE FLUSH MOUNTING OF THE METER BREAKER PEDESTAL AGAINST THE SIDE OF THE CABINET BASE (IF FLUSH MOUNTING POSSIBLE, CONFER WITH THE LOCAL UTILITY TO DETERMINE WHICH SIDE OF THE CONCRETE BASE THE ELECTRICAL SERVICE LATERAL WILL APPROACH, THEN FORM THAT INDICATED SIDE FOR FULL SIDE DEPTH.

WHILE FLUSH MOUNTING IS THE MOST DESIRABLE MOUNTING CONFIGURATION UTILITY REQUIREMENTS MAY PRECLUDE THIS OPTION. CONTRACTOR MUST PROVIDE UTILITY APPROVED PEDESTAL AND INSTALL PER UTILITY AND MANUFACTURERS REQUIREMENTS.

SERVICE CONDUCTOR ENTRANCES SHALL BE RIGID METALLIC CONDUIT, NIPPLES AND/OR CONDULETS AS REQUIRED.

SERVICE CONDUCTOR ENTRANCES SHALL BE SIZED AND LOCATED AS REQUIRED BY THE LOCAL UTILITY AND IN ACCORDANCE WITH APPROPRIATE ARTICLES OF THE LATEST ACCEPTED NATIONAL ELECTRICAL CODE.

IF MORE THAN ONE GROUNDING ELECTRODE IS REQUIRED, THE DISTANCE APART SHALL BE 6 FEET OR PER LOCAL UTILITY REGULATIONS.

\* SOME PEDESTAL LIGHTING PLANS SHOW MAIN LUGS ONLY.

CABINET SERVICE INSTALLATION (METER BREAKER PEDESTAL)	
STATE OF WISCONSIN DEPARTMENT OF TRANSPORTATION	
APPROVED DATE FHWA	/S/ Ahmet Demirbilek STATE ELECTRICAL ENGINEER

**FRONT INTERIOR ELEVATION**

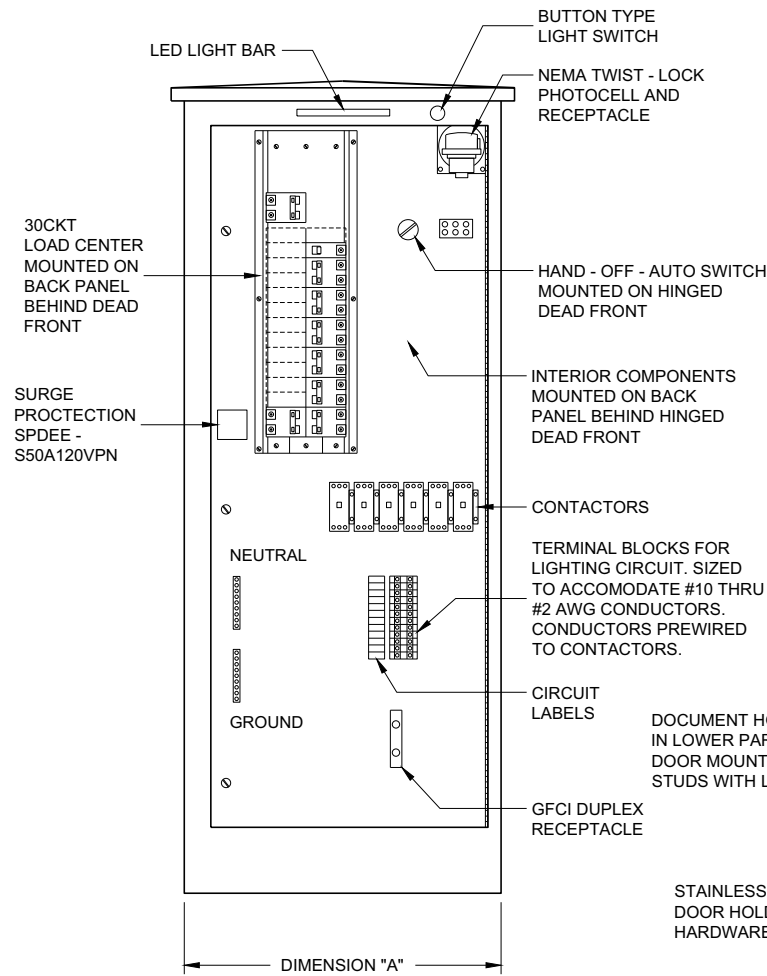

**SIDE VIEW**

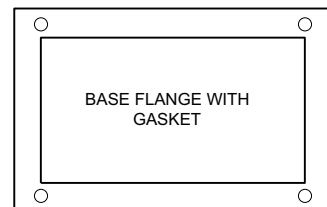
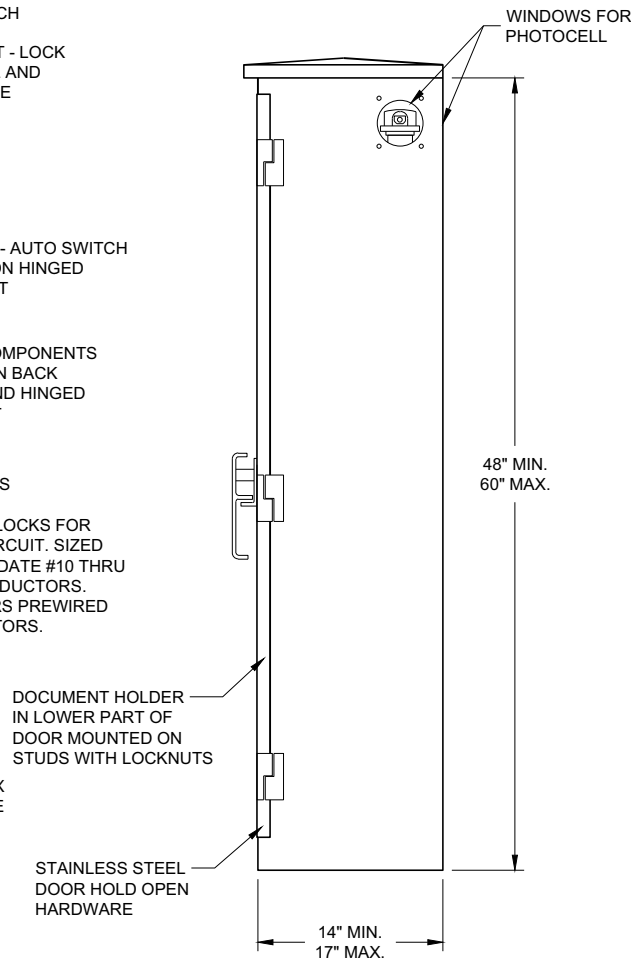
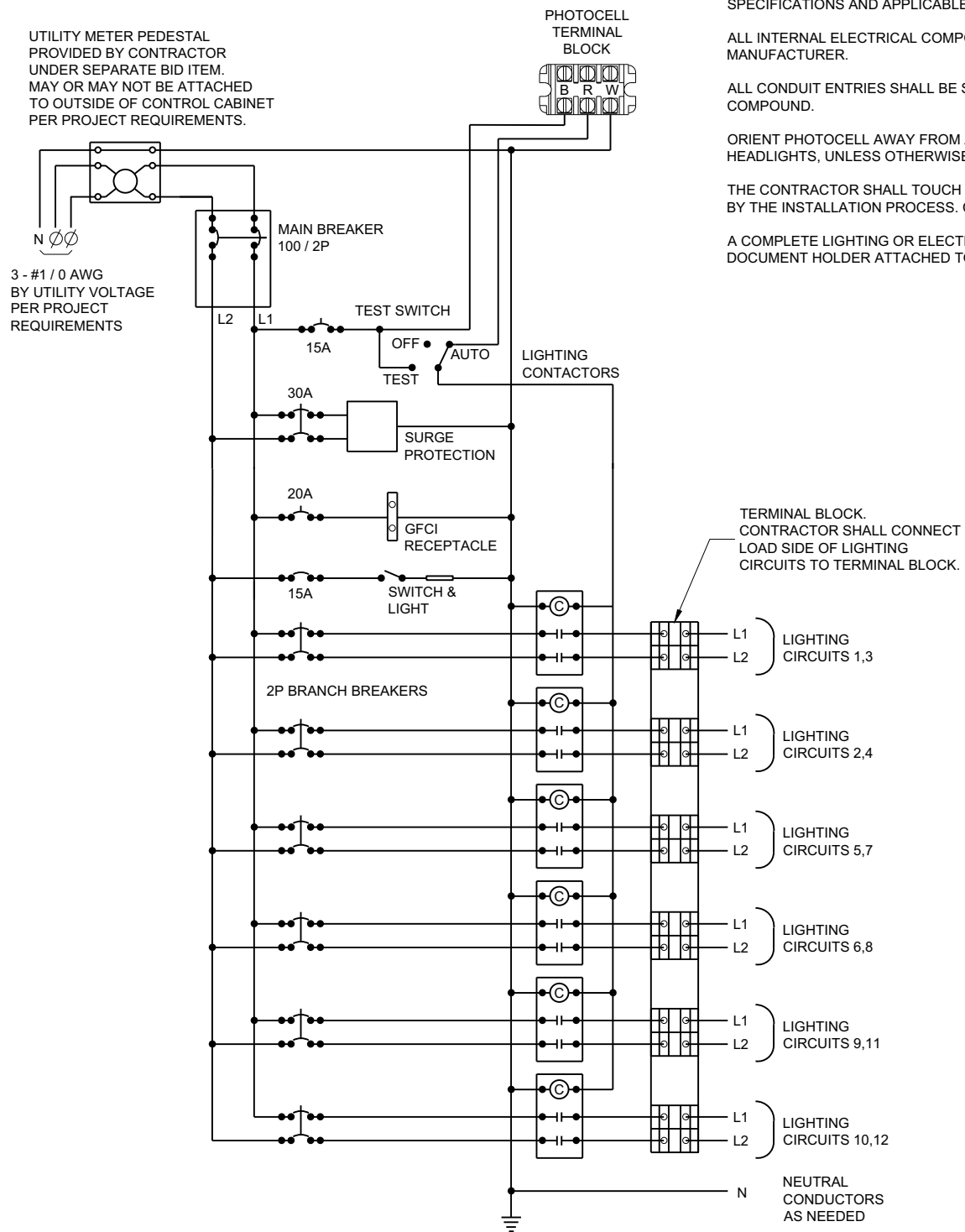

TABLE OF DIMENSIONS (INCHES)		
CONCRETE BASE TYPE	CABINET WIDTH	DIMENSION "A"
L24	24"	24"
L30	30"	30"

**LIGHTING CONTROL CABINET**



**CONTROL CABINET SCHEMATIC**

**GENERAL NOTES**

- DETAILS OF CONSTRUCTION, MATERIALS AND WORKMANSHIP NOT SHOWN ON THIS DRAWING SHALL CONFORM TO THE PERTINENT REQUIREMENTS OF THE STANDARD SPECIFICATIONS AND APPLICABLE SPECIAL PROVISIONS.
- ALL INTERNAL ELECTRICAL COMPONENTS WILL BE PRE - WIRED BY THE CABINET MANUFACTURER.
- ALL CONDUIT ENTRIES SHALL BE SEALED WITH AN APPROPRIATE DUCT SEALING COMPOUND.
- ORIENT PHOTOCELL AWAY FROM AMBIENT LIGHT SOURCES AND ONCOMING TRAFFIC HEADLIGHTS, UNLESS OTHERWISE CALLED FOR IN THE SPECIAL PROVISION.
- THE CONTRACTOR SHALL TOUCH UP ANY DAMAGE TO THE ANODIZED FINISH CAUSED BY THE INSTALLATION PROCESS. COLOR MATCH PAINT SHALL BE USED.
- A COMPLETE LIGHTING OR ELECTRICAL PLAN SHALL BE SECURELY PLACED IN THE DOCUMENT HOLDER ATTACHED TO THE DOOR.

**LIGHTING CONTROL CABINET  
120 / 240 VOLT**

STATE OF WISCONSIN  
DEPARTMENT OF TRANSPORTATION

APPROVED  
November 2018 /S/ Ahmet Demirelek  
DATE STATE ELECTRICAL ENGINEER  
FHWA



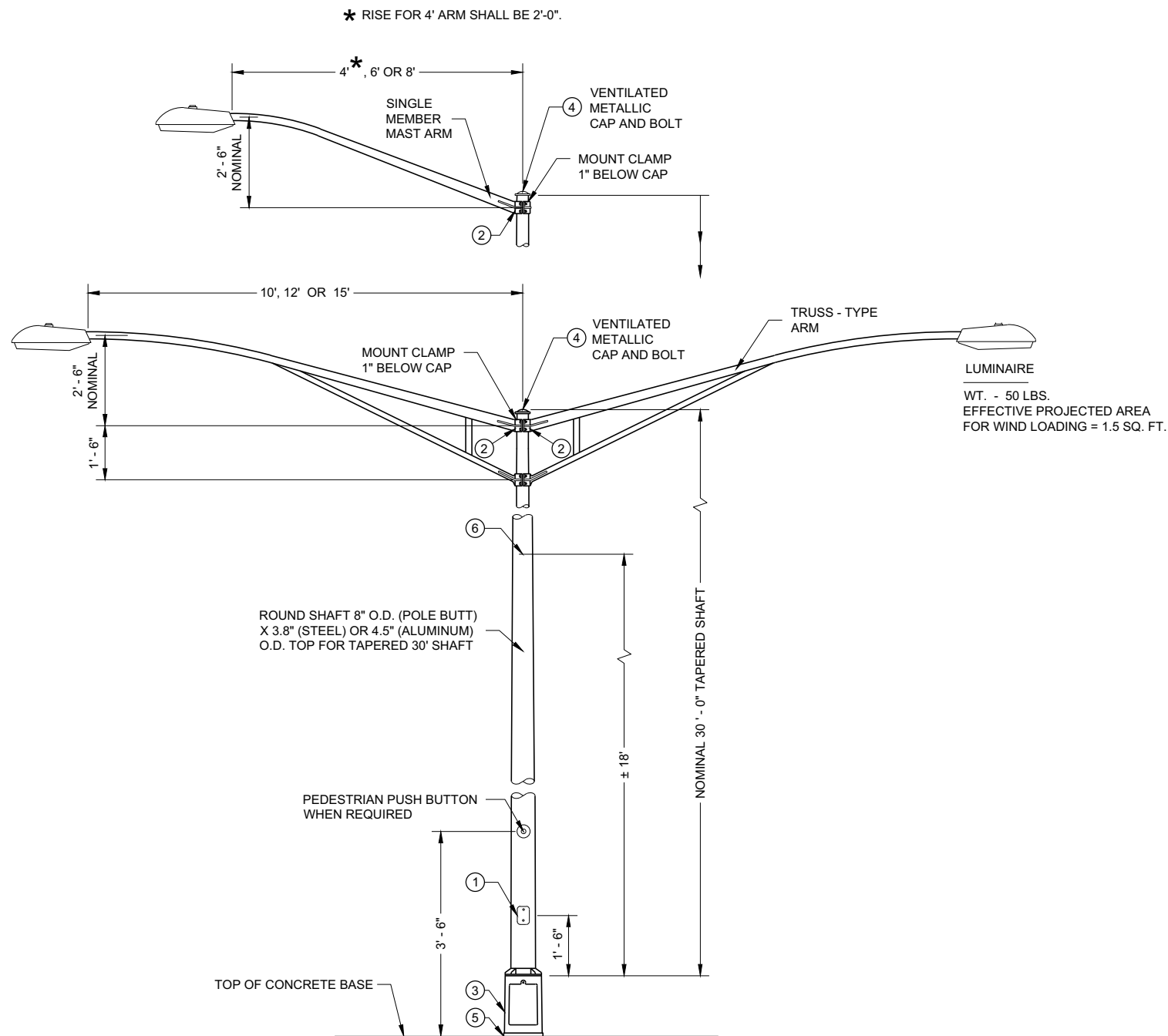

**TYPE 5 POLE MOUNTING CONFIGURATION  
(MAXIMUM LOAD)  
LIGHTING ONLY**

**GENERAL NOTES**

DETAILS OF CONSTRUCTION, MATERIALS AND WORKMANSHIP NOT SHOWN ON THIS DRAWING SHALL CONFORM TO THE PERTINENT REQUIREMENTS OF THE CONTRACT.

SECTION 657, POLES, OF THE STANDARD SPECIFICATIONS SHALL APPLY TO THIS DRAWING.

ALL TYPE 5 POLE MOUNTINGS SHALL BE DESIGNED TO INCLUDE TWIN 15' ARMS WITH LUMINAIRES.

POLES SHALL BE GALVANIZED STEEL OR ALUMINUM, AS CALLED FOR IN THE CONTRACT.

TYPE 5 ALUMINUM POLES SHALL BE CONSTRUCTED OF 6063 - T6 ALUMINUM ALLOY. SLEEVING INSIDE THE POLE IS NOT ACCEPTABLE.

TYPE 5 ALUMINUM POLES SHALL HAVE A MINIMUM WALL THICKNESS OF 0.1888".

TYPE 5 STEEL POLES SHALL HAVE A MINIMUM WALL THICKNESS OF U.S. STANDARD 11 GAGE (0.1196").

THE SLIPFITTER END OF THE LUMINAIRE MAST ARM SHALL BE A NOMINAL 2 3/8 INCHES IN OUTSIDE DIAMETER. THE STRAIGHT PORTION OF THE SLIPFITTER END OF THE LUMINAIRE MAST ARM SHALL BE A NOMINAL 12 INCHES IN LENGTH.

WHEN TRANSFORMER BASES ARE USED, WIRE CONNECTIONS SHALL BE MADE IN THE TRANSFORMER BASE.

- ① 4" X 6" REINFORCED HANDHOLE AND COVER ASSEMBLY WITH TWO (2) 1/4" X 3/4" - 20 TPI , STAINLESS STEEL, HEX HEAD BOLTS.
- ② GROMMETS. 1" CHASE NIPPLES OR 1" CLOSE CONDUIT NIPPLES WITH BUSHINGS SHALL BE PROVIDED FOR 1 3/8" HOLE IN POLE SHAFT FOR WIRING.
- ③ CAST ALUMINUM TRANSFORMER BASE, WHEN REQUIRED.
- ④ FURNISH AND INSTALL VENTILATED, CAST METALLIC (ALUMINUM ALLOY) CAPS. FASTEN CAPS WITH ONE (1) 1/4" X 3/4" - 20 TPI STAINLESS STEEL, HEX HEAD BOLT.
- ⑤ SHIMMING, IF NEEDED, SHALL BE LOCATED BETWEEN THE CONCRETE FOUNDATION AND POLE.
- ⑥ INTERNAL DUMBBELL - TYPE VIBRATION DAMPER.

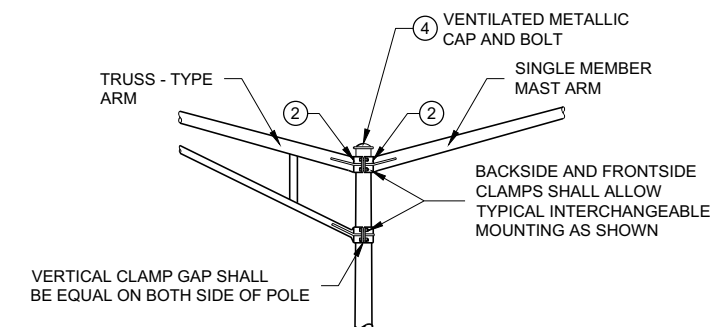

**INTERCHANGEABLE MOUNTING DETAIL**

<p><b>POLE MOUNTINGS FOR LIGHTING UNITS, TYPE 5 ( 30 FEET )</b></p>
<p>STATE OF WISCONSIN DEPARTMENT OF TRANSPORTATION</p>

**GENERAL NOTES**

DETAILS OF CONSTRUCTION, MATERIALS AND WORKMANSHIP NOT SHOWN ON THIS DRAWING SHALL CONFORM TO THE PERTINENT REQUIREMENTS OF THE CONTRACT.

THE EQUIPMENT GROUND CONNECTOR SHALL BE TAPED WITH 3 WRAPS (MINIMUM) OF APPROVED RUBBER TAPE AND 3 WRAPS (MINIMUM) OF APPROVED VINYL TAPE TO COVER SHARP WIRE ENDS AFTER THE CONNECTION IS COMPLETED.

WHEN TRANSFORMER BASES ARE USED, ALL WIRING CONNECTIONS SHALL OCCUR WITHIN THE TRANSFORMER BASES.

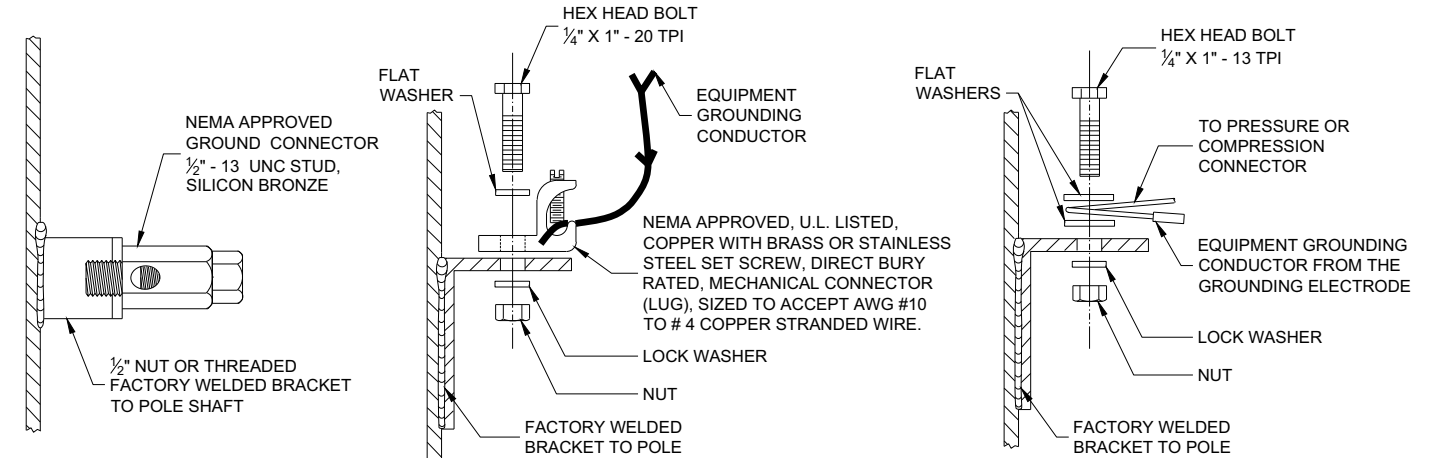
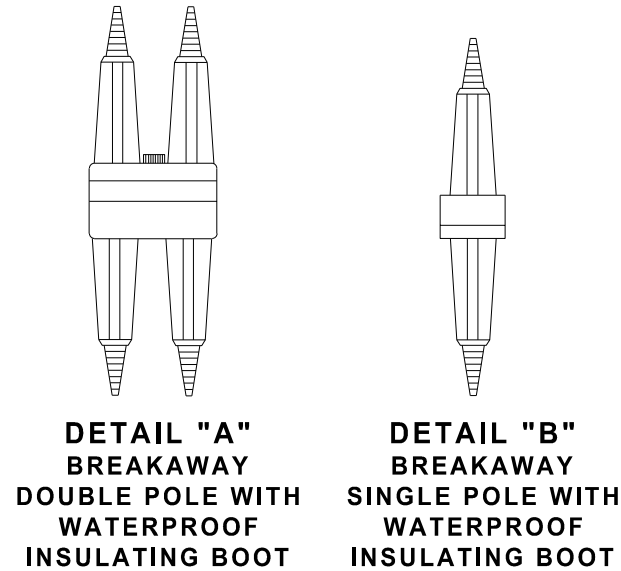
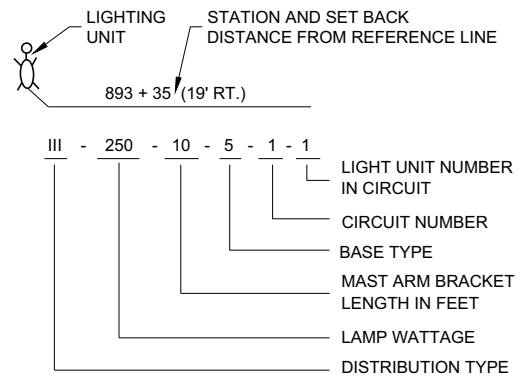

**TYPICAL GROUNDING CONNECTIONS**  
NUT, BOLT AND WASHERS SHALL BE STAINLESS STEEL

**LIGHTING UNIT CODE (TYPICAL)**

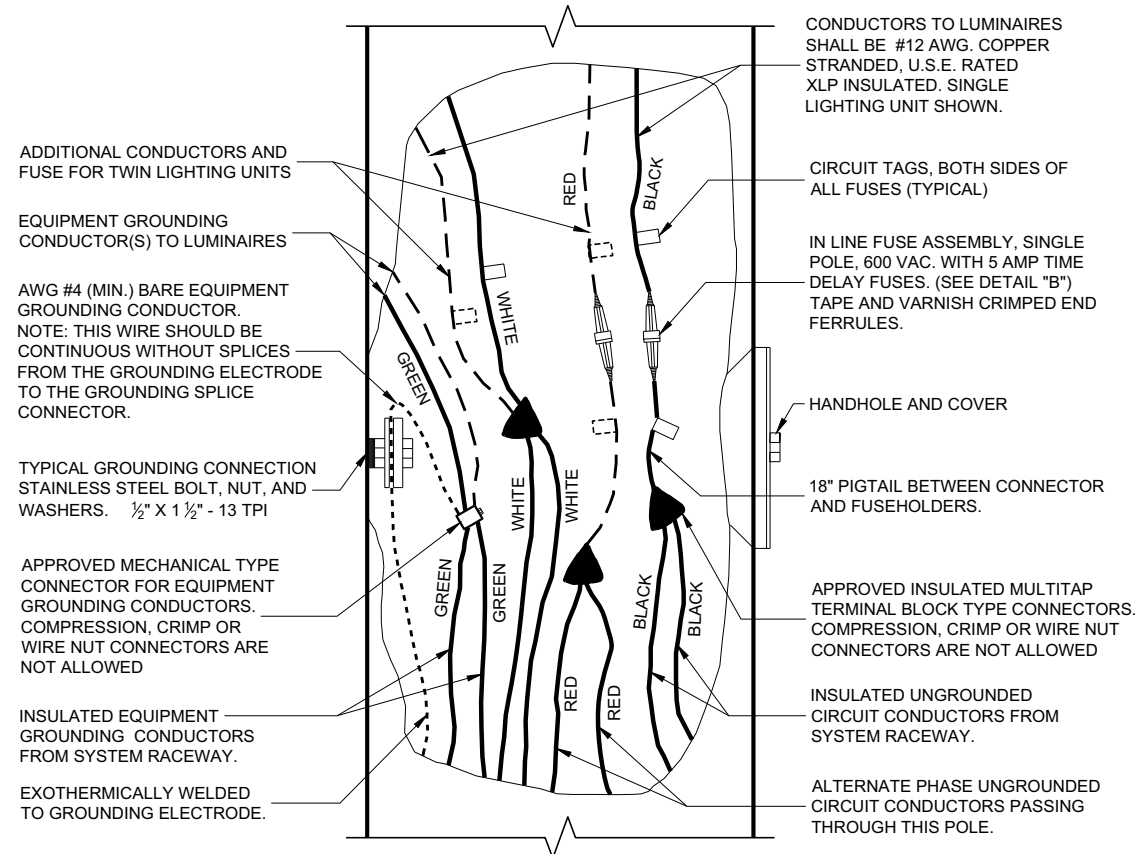

**3 WIRE - 120, 240 OR 480 VAC (UNGROUNDING CONDUCTORS) WITH GROUNDING CONDUCTOR AND EQUIPMENT GROUNDING CONDUCTOR**

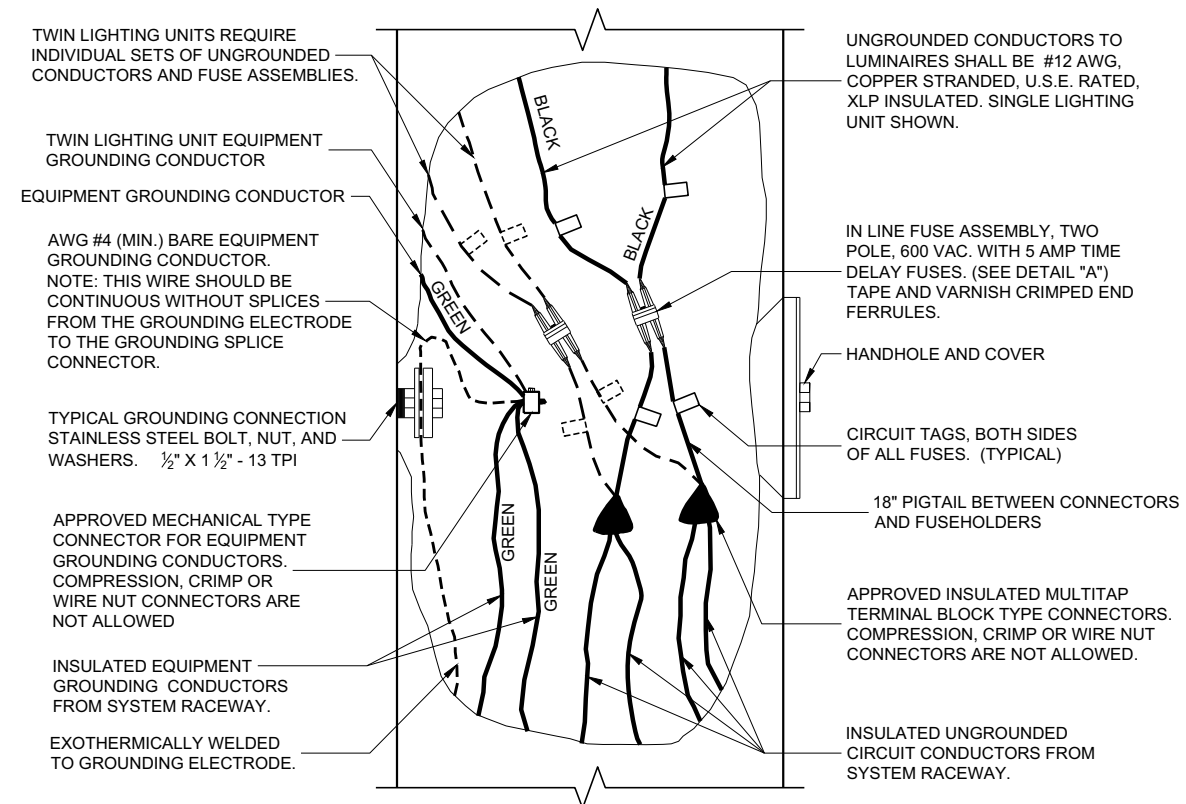

**2 WIRE - 240 OR 480 VAC (UNGROUNDING CONDUCTORS) WITH EQUIPMENT GROUNDING CONDUCTOR**

**NON - FREEWAY LIGHTING UNIT POLE WIRING**

STATE OF WISCONSIN  
DEPARTMENT OF TRANSPORTATION

APPROVED  
November 2018 /S/ Ahmet Demirelek  
DATE STATE ELECTRICAL ENGINEER

FHWA

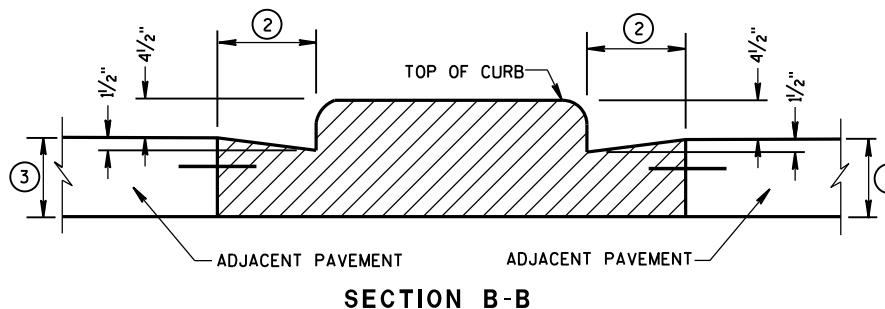
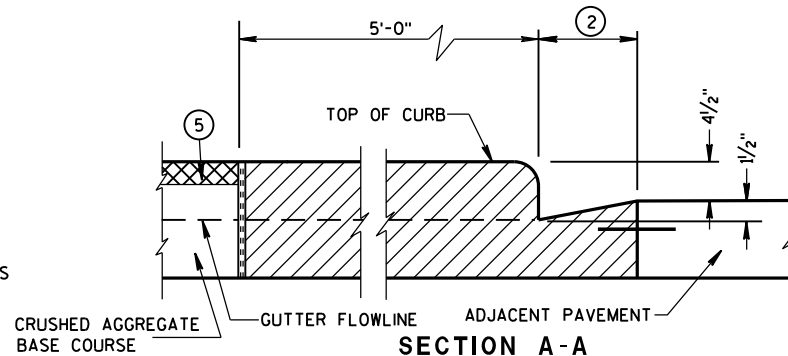
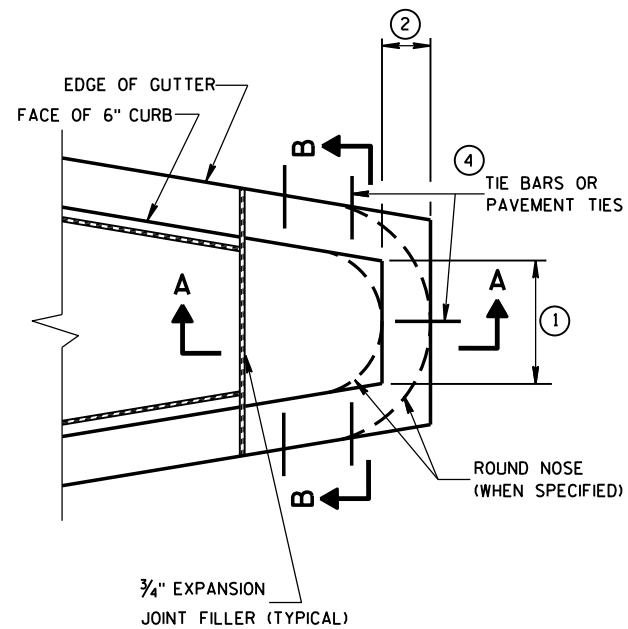
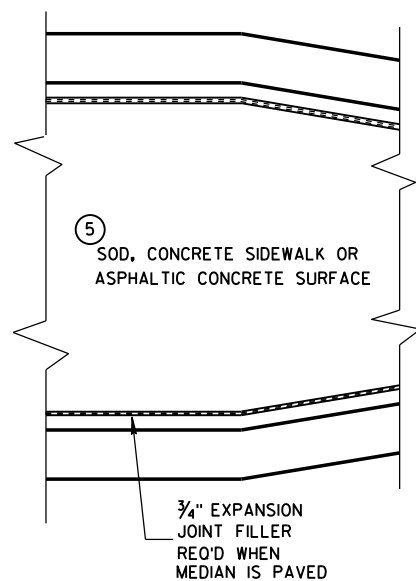

CONCRETE MEDIAN BLUNT NOSE DETAIL

GENERAL NOTES

DETAILS OF CONSTRUCTION, MATERIALS AND WORKMANSHIP NOT SHOWN ON THIS DRAWING SHALL CONFORM TO THE PERTINENT REQUIREMENTS OF THE STANDARD SPECIFICATIONS AND THE APPLICABLE SPECIAL PROVISIONS.

- ① SEE PLAN FOR MEDIAN NOSE WIDTH AND RADIUS (FOR ROUND NOSE ALTERNATE).
- ② WIDTH OF GUTTER TO MATCH EXISTING ADJACENT GUTTER OR AS SPECIFIED ELSEWHERE IN THE PLAN.
- ③ DEPTH EQUAL TO ADJACENT PAVEMENT. ADJACENT PAVEMENT STRUCTURE DETAILS ARE SHOWN ON THE PLAN. TYPICAL OPTIONS ARE:
  - (1) NEW OR EXISTING CONCRETE PAVEMENT.
  - (2) ASPHALTIC CONCRETE PAVEMENT OVER NEW OR EXISTING CONCRETE BASE COURSE.
  - (3) ASPHALTIC CONCRETE PAVEMENT OVER CRUSHED AGGREGATE BASE COURSE.
- ④ TIE BARS OR PAVEMENT TIES REQUIRED IN NEW CONCRETE PAVEMENT OR CONCRETE BASE COURSE. TIE BARS SHALL BE NO. 4 X 2'-0" SPACED AT 2'-0" C-C.
- PAVEMENT TIES REQUIRED IN EXISTING CONCRETE BASE COURSE. PAVEMENT TIES SHALL BE NO. 6 X 1'-0" SPACED AT 3'-0" C-C INSTALLED ON A HORIZONTAL SKEW OF 6:1. THE DIRECTION OF SKEW SHALL ALTERNATE AFTER EVERY ONE OR TWO BARS.
- ⑤ SURFACE TYPE AND DETAILS ARE SHOWN ELSEWHERE IN THE PLAN.

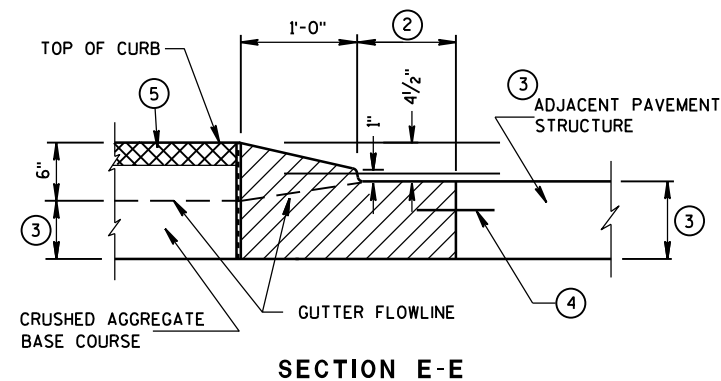
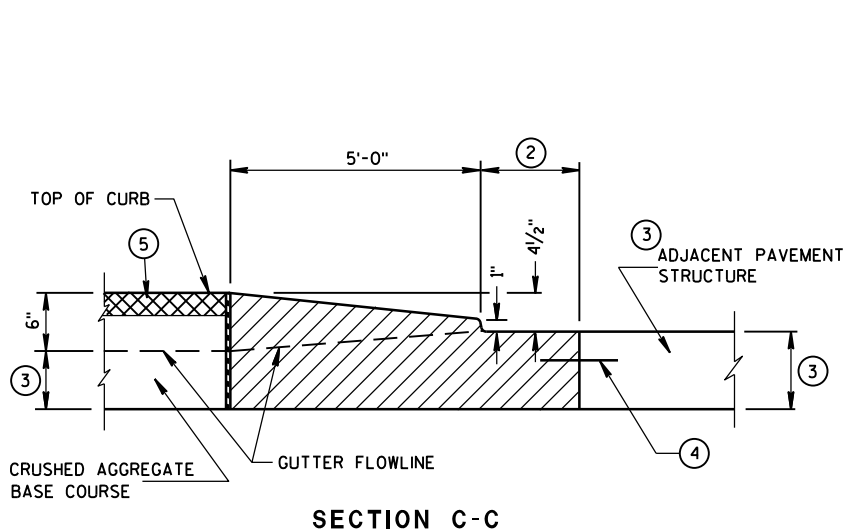
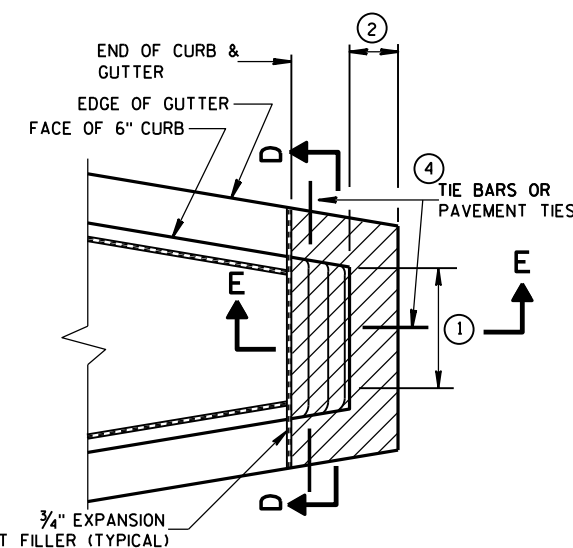

CONCRETE MEDIAN SLOPED NOSE TYPE 2

CONCRETE MEDIAN SLOPED NOSE TYPE 1

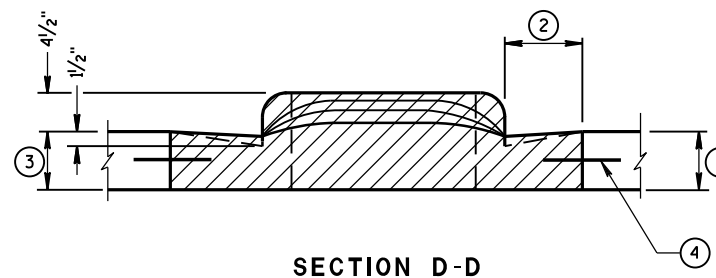

CONCRETE MEDIAN NOSE

STATE OF WISCONSIN  
DEPARTMENT OF TRANSPORTATION

APPROVED

6/8/2006  
DATE

FHWA

/s/ Jerry H. Zogg  
ROADWAY STANDARDS DEVELOPMENT  
ENGINEER

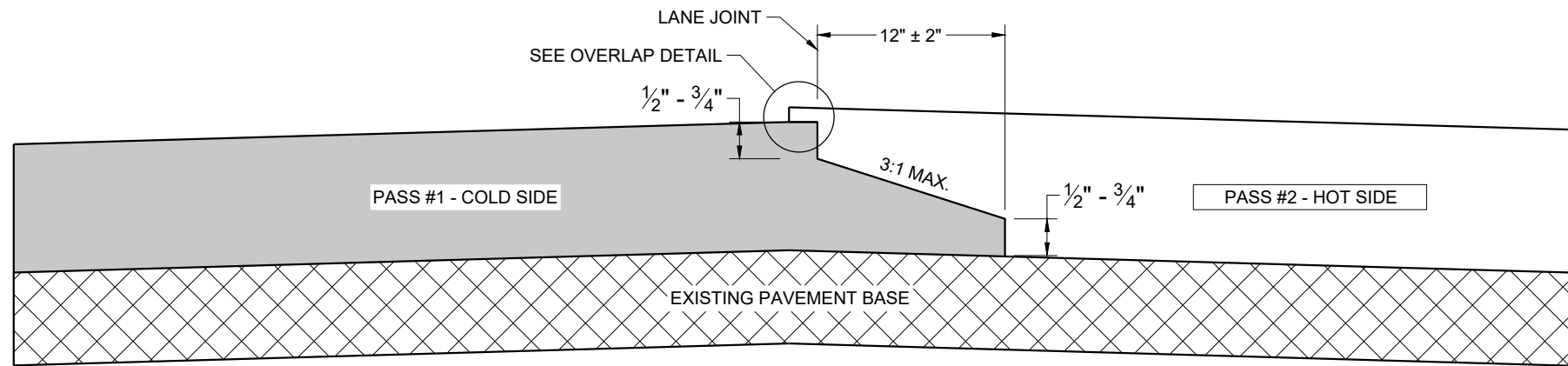

**TYPICAL PAVEMENT CROSS SECTION  
NOTCHED WEDGE JOINT**

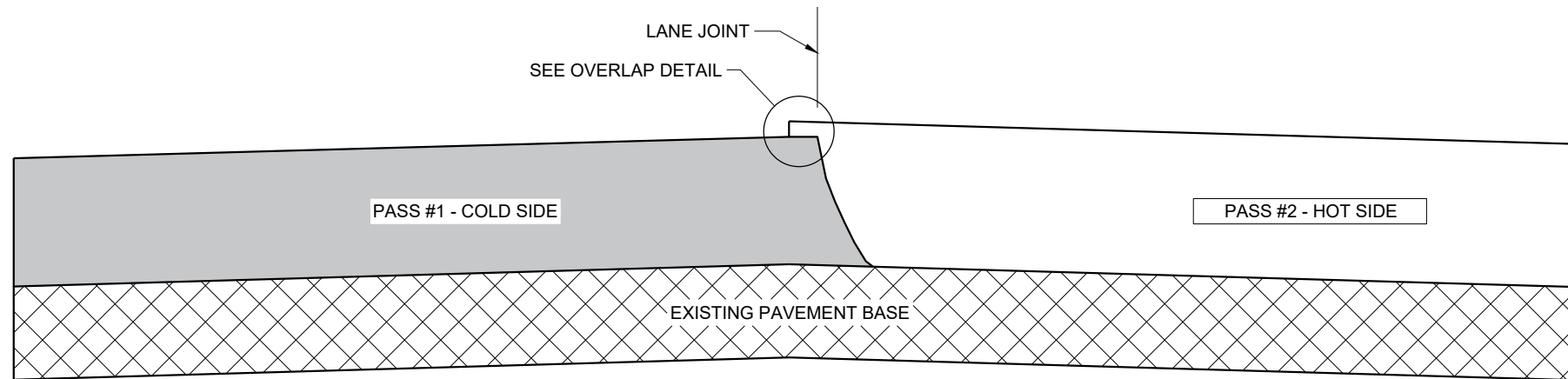

**TYPICAL PAVEMENT CROSS SECTION  
VERTICAL JOINT**

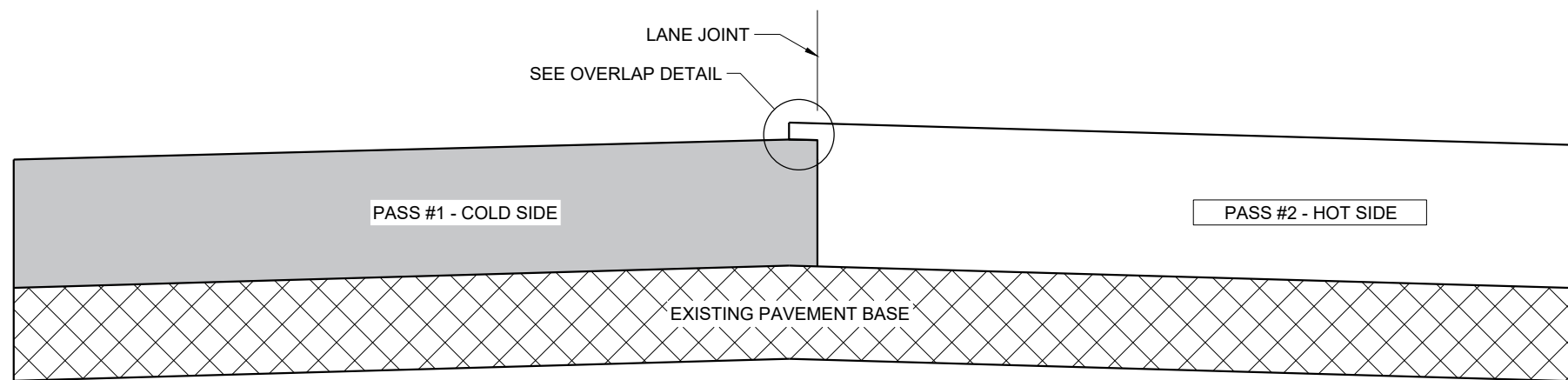

**TYPICAL PAVEMENT CROSS SECTION  
VERTICAL JOINT (MILLED)**

**GENERAL NOTES**

IN ADDITION TO THE DETAILS PROVIDED IN THIS DRAWING, CONFORM TO STANDARD SPECIFICATION 450.3.2.8 FOR WHEN A NOTCHED WEDGE JOINT IS REQUIRED AND FOR GENERAL JOINT CONSTRUCTION REQUIREMENTS.

FOR ALL LONGITUDINAL JOINTS, ENSURE THE PAVER SCREED OVERLAPS THE PREVIOUSLY PLACED PAVEMENT BY  $1" \pm 0.5"$  AND THE HOT SIDE OF THE JOINT REMAINS HIGHER THAN THE COLD SIDE BY APPROXIMATELY  $0.1"$  AFTER FINAL COMPACTION. (IT WILL BE FLUSH WHEN PAVING IN ECHELON.)

ONLY REMOVE THE LONGITUDINAL NOTCHED WEDGE JOINT FOR SMA PAVEMENT OR AS DIRECTED BY THE ENGINEER TO ADDRESS SPECIFIC LENGTHS OF JOINT DAMAGED BY TRAFFIC.

WHEN MILLING BACK OR REMOVING ANY LONGITUDINAL JOINT, LIMIT THE MATERIAL REMOVED TO  $2"$  FROM THE TOP NOTCH OR FROM THE VERTICAL JOINT EDGE ON THE COLD SIDE OF THE JOINT.

USE LONGITUDINAL MILLED JOINT AS PLANS SHOW OR THE AS THE ENGINEER DIRECTS.

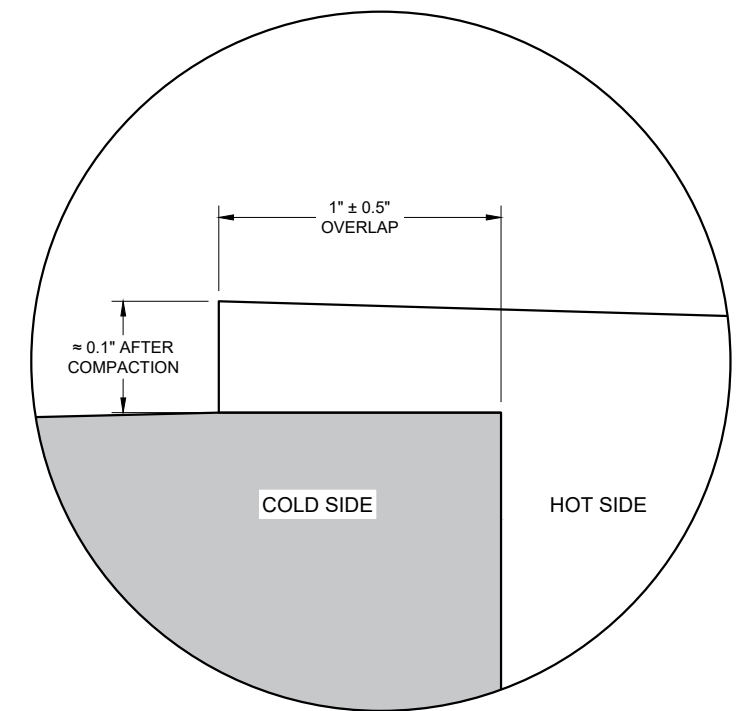

**OVERLAP DETAIL (TYPICAL)**

6

6

SDD 13C19 - 03

SDD 13C19 - 03

<b>HMA LONGITUDINAL JOINTS</b>	
STATE OF WISCONSIN DEPARTMENT OF TRANSPORTATION	
APPROVED November 2020 DATE	/S/ Steven Hefel HMA PAVEMENT ENGINEER
FHWA	

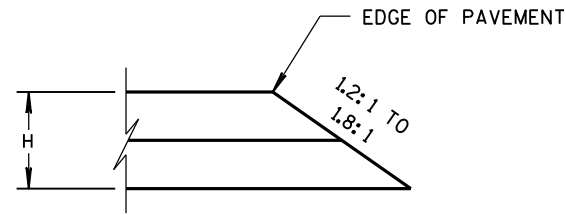

CONSTRUCTED WITH FINAL TWO LAYERS  
FOR H 5" OR LESS

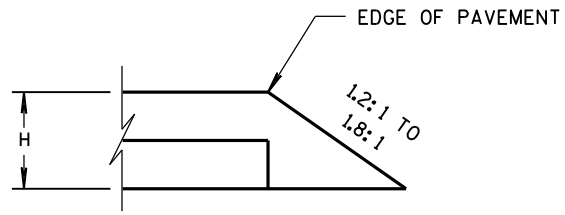

CONSTRUCTED WITH FINAL LAYER  
FOR H 5" OR LESS

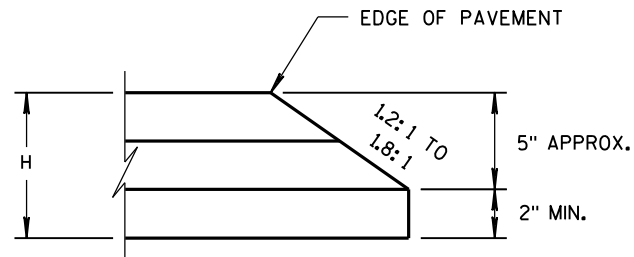

CONSTRUCTED WITH FINAL TWO LAYERS  
FOR H GREATER THAN 5"

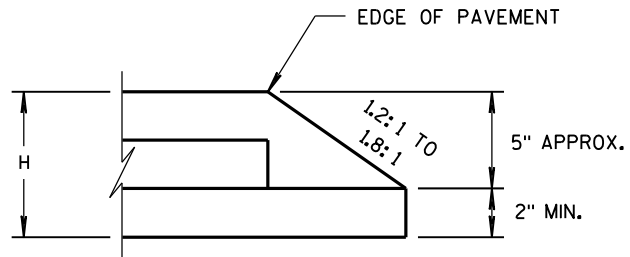

CONSTRUCTED WITH FINAL LAYER  
FOR H GREATER THAN 5"

HMA PAVEMENT AND HMA OVERLAYS

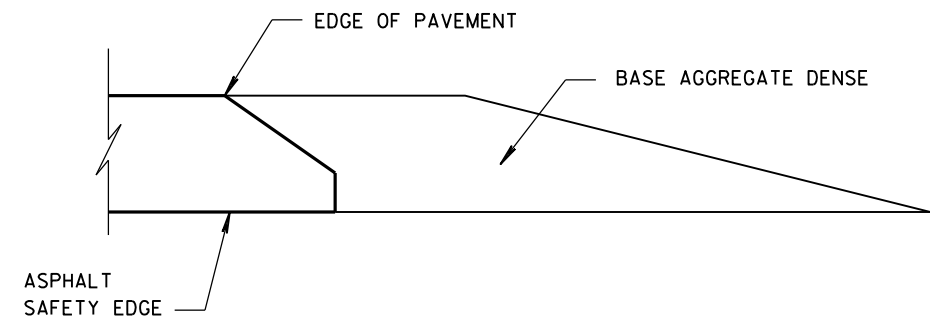

FINISHED SHOULDER AGGREGATE PLACEMENT

6

6

S.D.D. 14 B 29-1

S.D.D. 14 B 29-1

SAFETY EDGE <sub>SM</sub>	
STATE OF WISCONSIN DEPARTMENT OF TRANSPORTATION	
APPROVED DATE	/s/ Jerry H. Zogg ROADWAY STANDARDS DEVELOPMENT ENGINEER
FHWA	

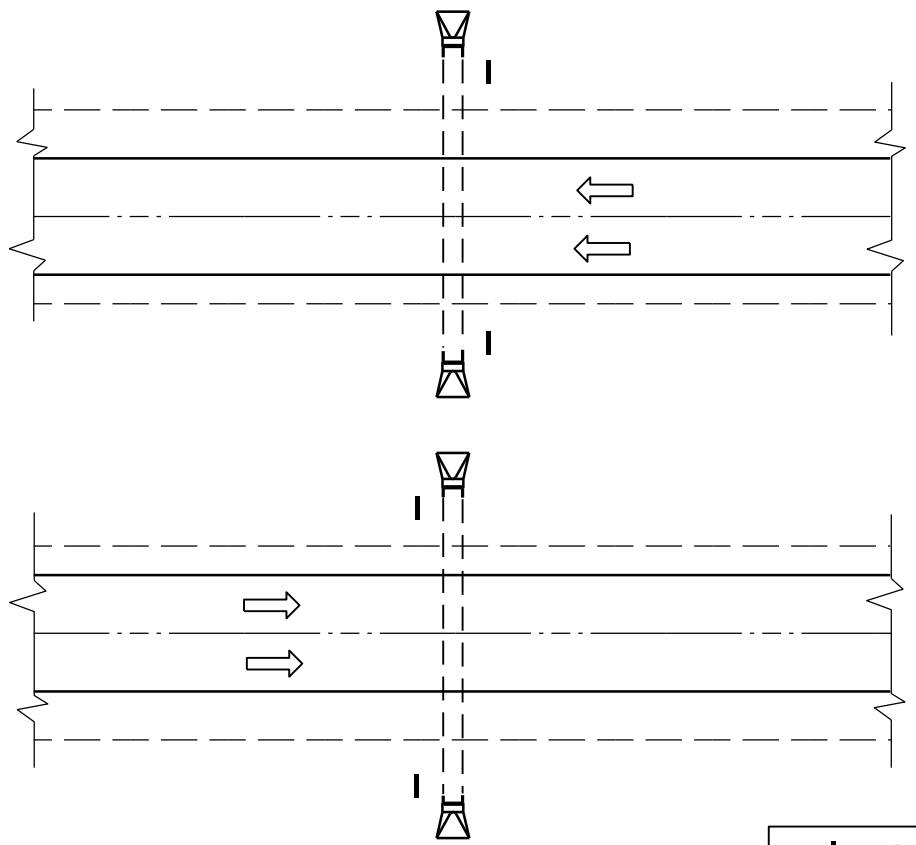

PLAN VIEW  
DIVIDED HIGHWAY

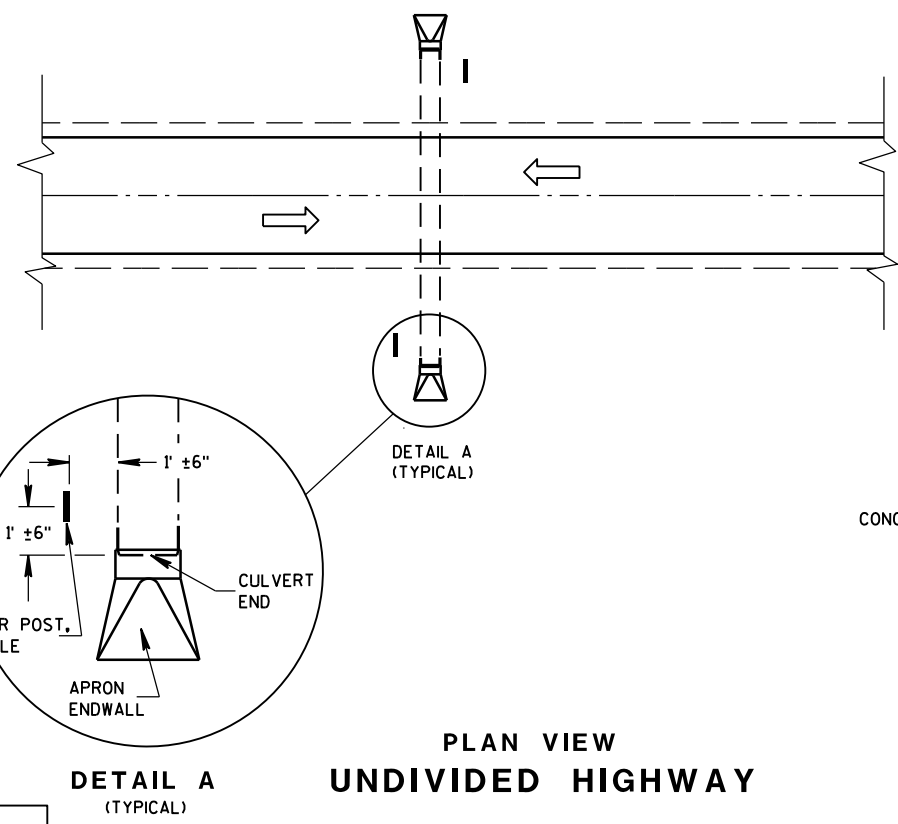

PLAN VIEW  
UNDIVIDED HIGHWAY

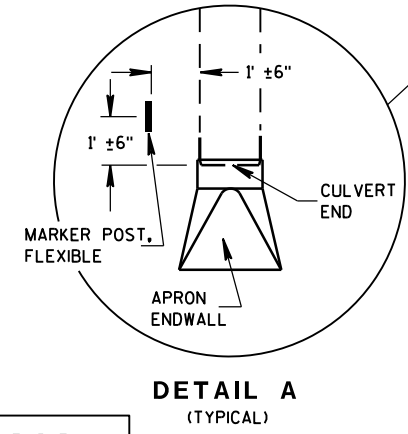

DETAIL A  
(TYPICAL)

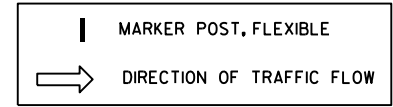

FLEXIBLE MARKER POST LOCATION

GENERAL NOTES

DETAILS OF CONSTRUCTION, MATERIALS AND WORKMANSHIP NOT SHOWN ON THIS DRAWING SHALL CONFORM TO THE PERTINENT REQUIREMENTS OF THE STANDARD SPECIFICATIONS AND THE APPLICABLE SPECIAL PROVISIONS.

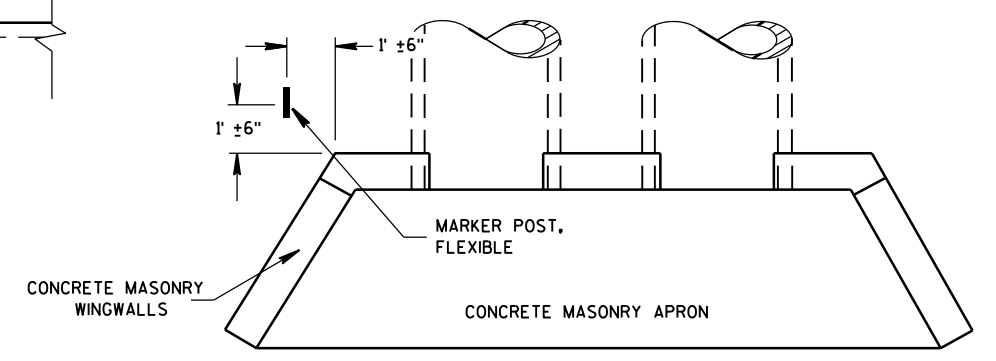

PLAN VIEW  
CONCRETE MASONRY ENDWALLS FOR  
CULVERT PIPE AND PIPE ARCH

6

6

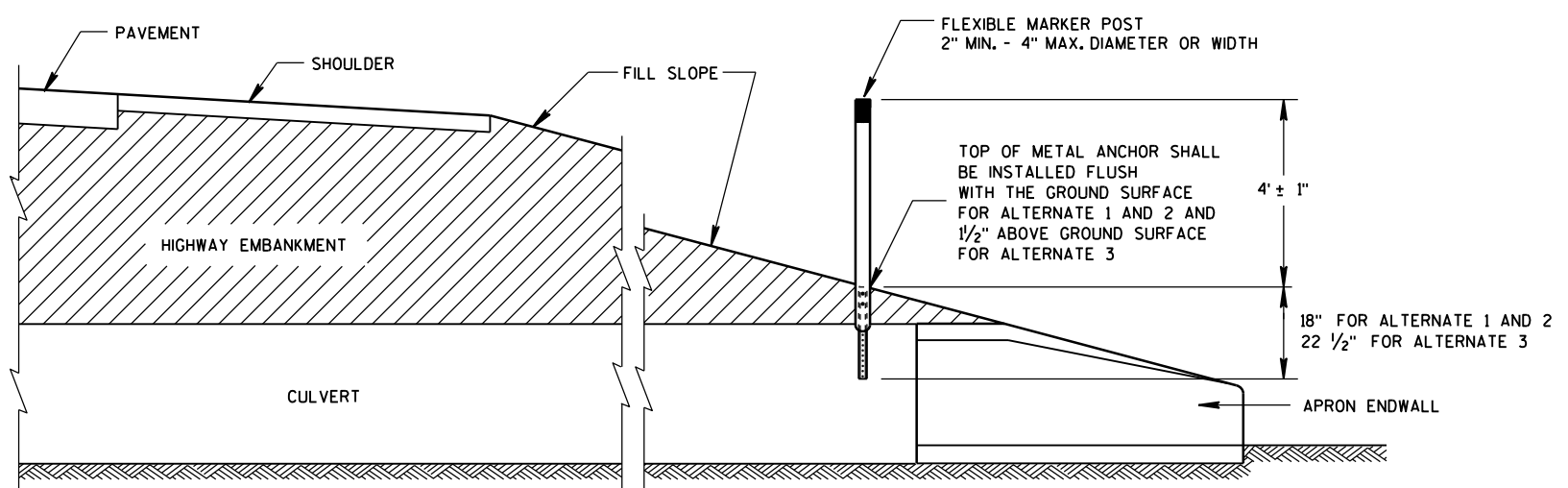

CROSS SECTION  
FLEXIBLE MARKER POST

FLEXIBLE MARKER POST  
FOR CULVERT END

STATE OF WISCONSIN  
DEPARTMENT OF TRANSPORTATION

S.D.D. 15 A 3-2a

S.D.D. 15 A 3-2a

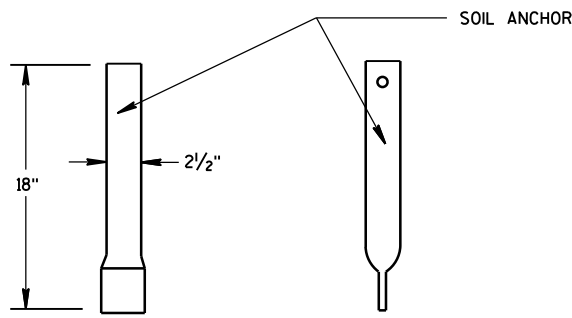
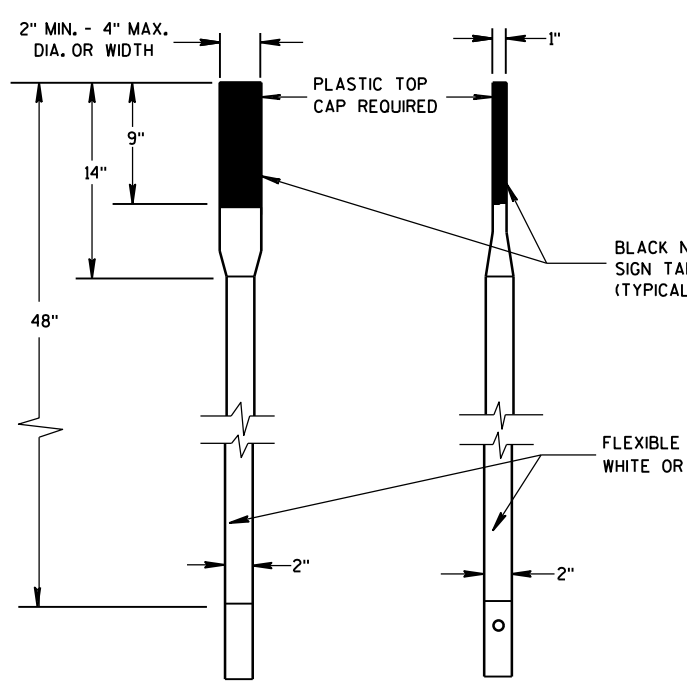

FRONT VIEW SIDE VIEW  
ALTERNATE 1

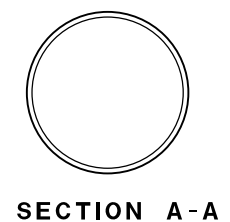

SECTION A-A

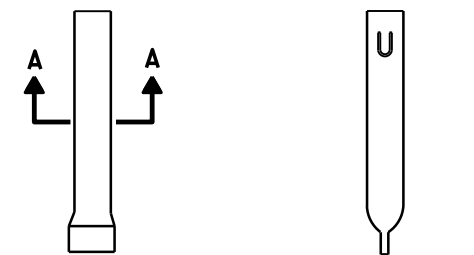

FRONT VIEW SIDE VIEW  
ALTERNATE 1

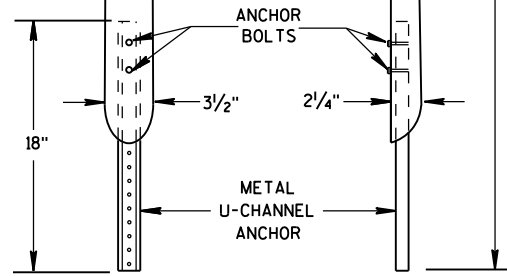
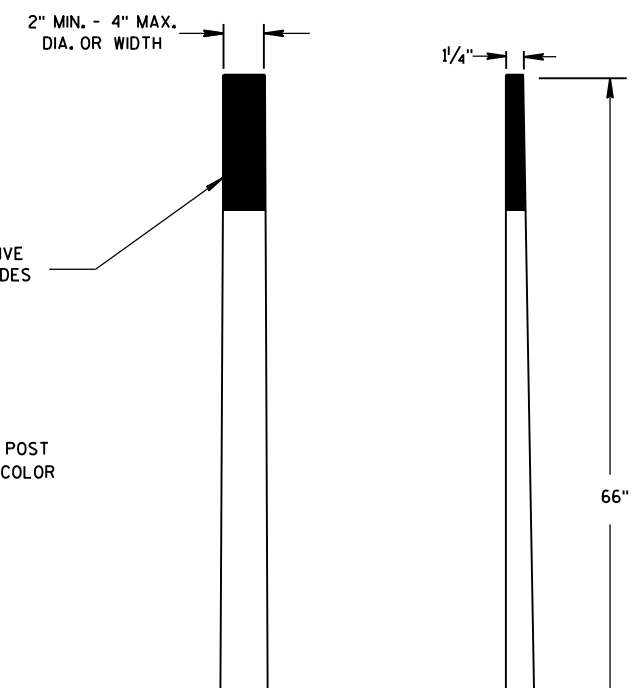

FRONT VIEW SIDE VIEW  
ALTERNATE 2

**FLEXIBLE MARKER POSTS**

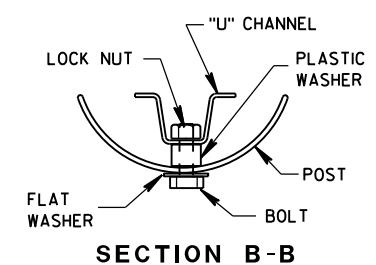

SECTION B-B

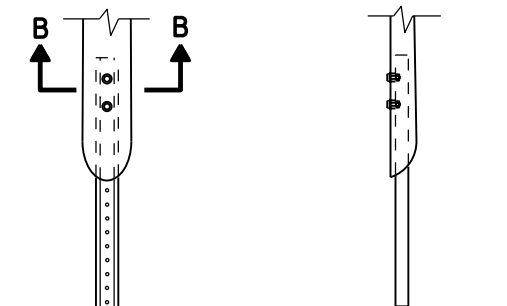

FRONT VIEW SIDE VIEW  
ALTERNATE 2

**FLEXIBLE MARKER POST ANCHORS**

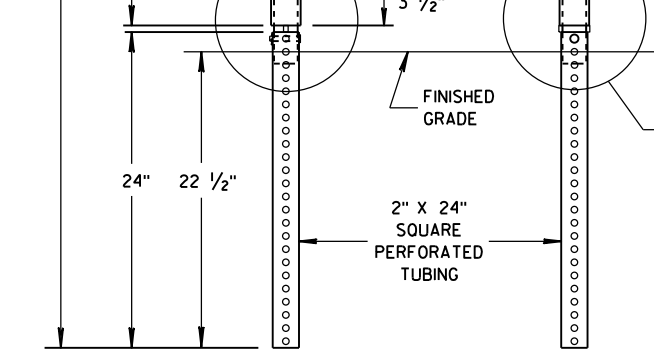
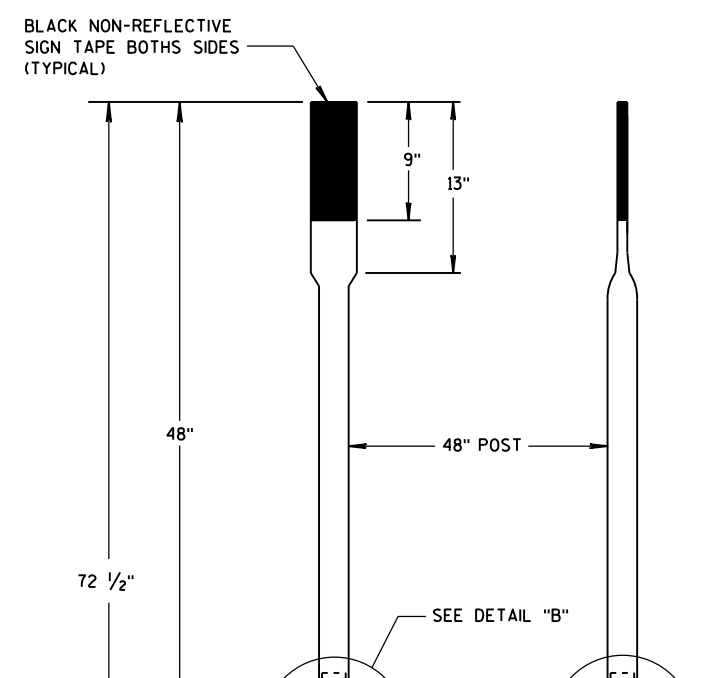

FRONT VIEW SIDE VIEW  
ALTERNATE 3

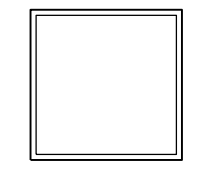

SECTION C-C

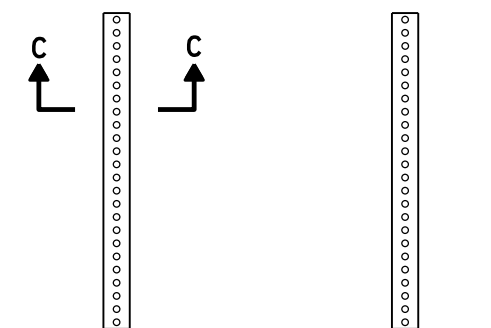

FRONT VIEW SIDE VIEW  
ALTERNATE 3

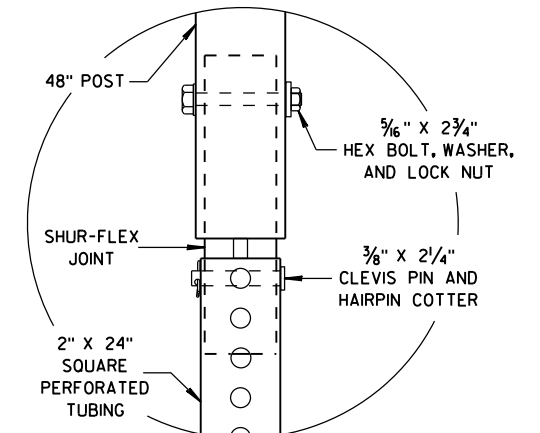

DETAIL B

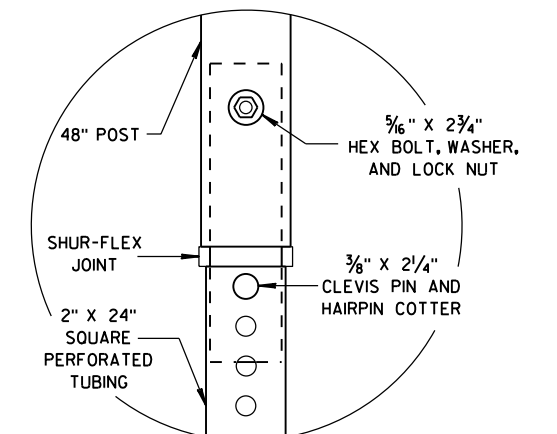

DETAIL C

**FLEXIBLE MARKER POST FOR CULVERT END**

STATE OF WISCONSIN  
DEPARTMENT OF TRANSPORTATION

APPROVED  
10/1/2012 DATE /S/ Travis Feltes  
STATE TRAFFIC ENGINEER OF DESIGN  
FHWA

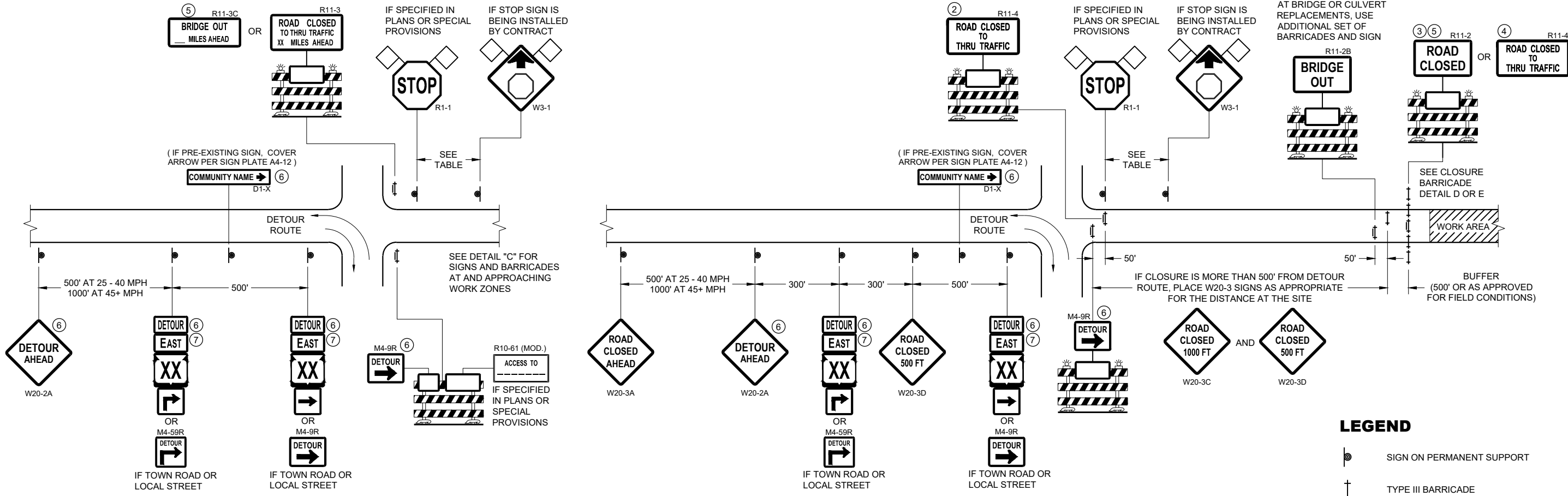

**DETAIL A  
MAINLINE CLOSURE WITH POSTED DETOUR**

WORK ZONE GREATER THAN OR EQUAL TO 1/2 MILE FROM  
DETOUR ROUTE ( 1000 FEET IF URBAN )

**DETAIL B  
MAINLINE CLOSURE WITH POSTED DETOUR**

WORK ZONE LESS THAN 1/2 MILE FROM  
DETOUR ROUTE ( 1000 FEET IF URBAN )

**LEGEND**

- SIGN ON PERMANENT SUPPORT
- TYPE III BARRICADE
- TYPE III BARRICADE WITH ATTACHED SIGN
- TYPE "A" WARNING LIGHT (FLASHING)
- WORK AREA
- FLAGS, 16" X 16" MIN. (ORANGE)

SPEED LIMIT (MPH)	"STOP AHEAD" ADVANCE WARNING DISTANCE (FT)
25	200
30	200
35	350
40	350
45	500
50	550
55	750

M4 - 8  
 M3 - X  
 M1 - 4 OR M1 - 6 OR M1 - 5A  
 M05 - 1 OR M06 - 1

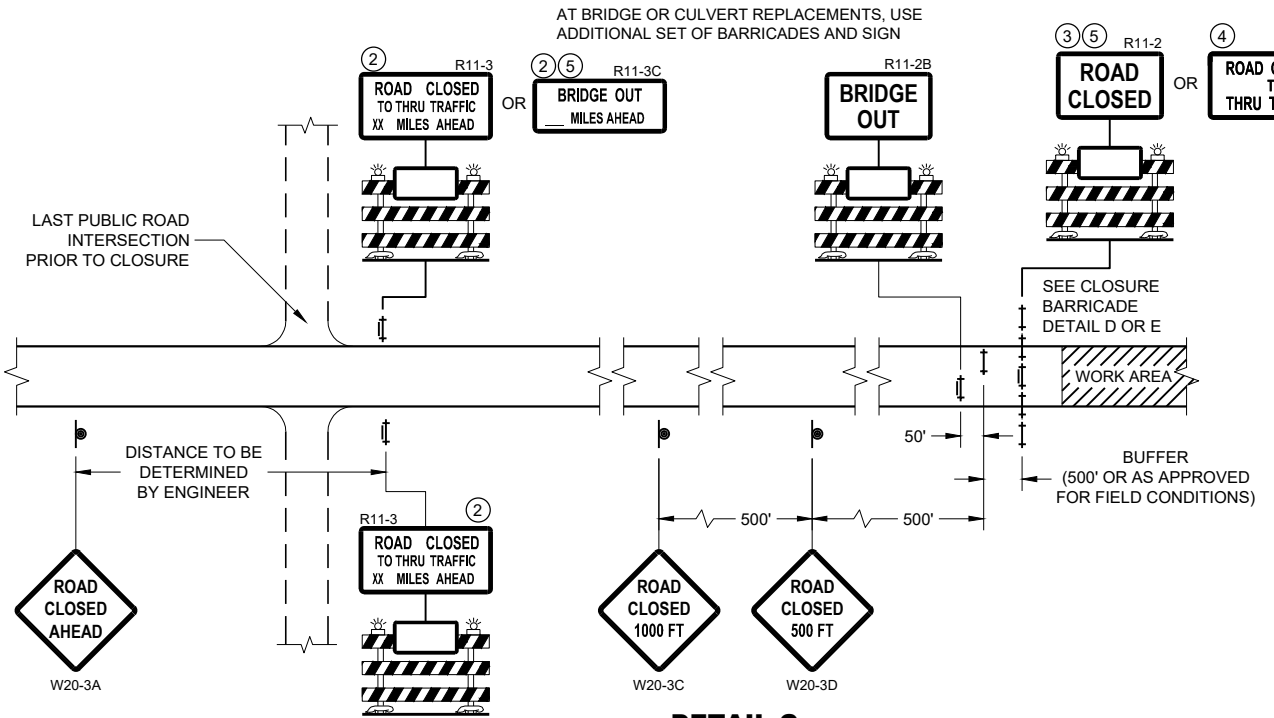

**DETAIL C  
MAINLINE CLOSURE, NO POSTED DETOUR**

SEE SDD 15C2-SHEET "b"  
FOR GENERAL NOTES  
AND FOOTNOTES ① THROUGH ⑦

**BARRICADES AND SIGNS  
FOR MAINLINE CLOSURES**

STATE OF WISCONSIN  
DEPARTMENT OF TRANSPORTATION

APPROVED  
May 2023 /S/ Andrew Heidtke  
DATE DATE WORK ZONE ENGINEER

FHWA



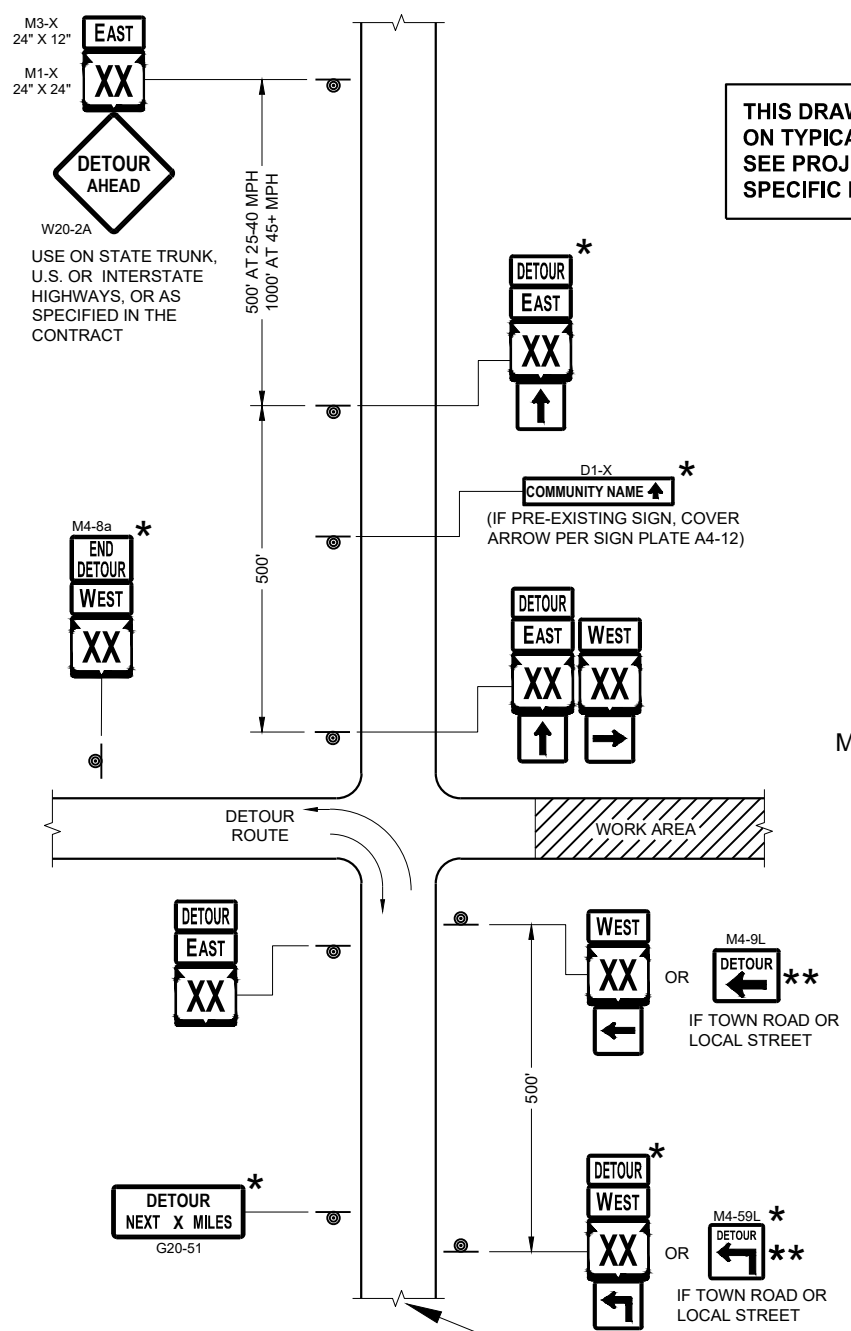

THIS DRAWING PROVIDES GENERAL GUIDANCE ON TYPICAL DETOUR SIGN LAYOUT AND SPACING. SEE PROJECT DETOUR SIGNING SHEETS FOR SPECIFIC DETAILS FOR EACH PROJECT.

**LEGEND**

- SIGN ON PERMANENT SUPPORT
- WORK AREA
- M4 - 8
- M3 - X
- M1 - 4
- M1 - 6
- M1 - 5A
- M05 - 1
- M06 - 1
- M06 - 1

**GENERAL NOTES**

THE EXACT NUMBER, LOCATION AND SPACING OF ALL SIGNS SHALL BE ADJUSTED TO FIT FIELD CONDITIONS AS APPROVED BY THE ENGINEER.

IF THERE ARE EXISTING ROUTE MARKER ASSEMBLIES THAT WILL REMAIN IN PLACE, ADJUST THE LOCATION OF THE DETOUR ROUTE SIGNS TO CORRESPOND WITH THE EXISTING ASSEMBLIES. SEE SPECIFIC PROJECT DETOUR SIGNING DETAIL SHEETS. MODIFY EXISTING SIGNS WHERE POSSIBLE.

THE SPACING BETWEEN TRAFFIC CONTROL AND DETOUR SIGNS SHOULD BE ADJUSTED TO NOT CONFLICT WITH AND TO PROVIDE A DESIRABLE MINIMUM OF 200 FEET CLEARANCE TO EXISTING SIGNS THAT WILL REMAIN IN PLACE.

ANY SIGNS TEMPORARY OR EXISTING, WHICH CONFLICT WITH TRAFFIC CONTROL "IN USE" SHALL BE REMOVED OR COVERED AS NEEDED AND AS APPROVED BY THE ENGINEER.

SIGNS THAT WILL BE IN PLACE LESS THAN 7 CONTINUOUS DAYS AND NIGHTS MAY BE MOUNTED ON PORTABLE SUPPORTS.

"MO" SIGNS ARE THE SAME AS "M" SIGNS EXCEPT THE BACKGROUND IS ORANGE.

SIGN SIZES SHALL BE AS FOLLOWS:

- M3-X SHALL BE 24" X 12" (36" X 18" IF NEEDED TO MATCH EXISTING SIGNS)
- M4-8 SHALL BE 24" X 12" (36" X 18" IF NEEDED TO MATCH EXISTING SIGNS)
- M1-4, M1-5A AND M1-6 SHALL BE 24" X 24" (36" X 36" IF NEEDED TO MATCH EXISTING SIGNS)
- M05-1 AND M06-1 SHALL BE 21" X 21" (30" X 30" IF NEEDED TO MATCH EXISTING SIGNS)
- M4-9 AND M4-59 SHALL BE 30" X 24"
- M4-8a SHALL BE 24" X 18"
- G20-51 SHALL BE 60" X 24"
- W20-2A SHALL BE 48" X 48"
- D1-X SHALL BE AS SHOWN ON SPECIFIC PROJECT SIGNING DETAIL SHEETS.

- \* OPTIONAL SIGNS. SEE SPECIFIC PROJECT DETOUR SIGNING DETAIL SHEETS.
- \*\* FOR A TOWN ROAD OR LOCAL STREET DETOURED ONTO A STATE TRUNK HIGHWAY, PLACE A ROAD NAME PLAQUE ABOVE THE M4-9 SIGN AS SPECIFIED IN THE CONTRACT.

MATCH POINT

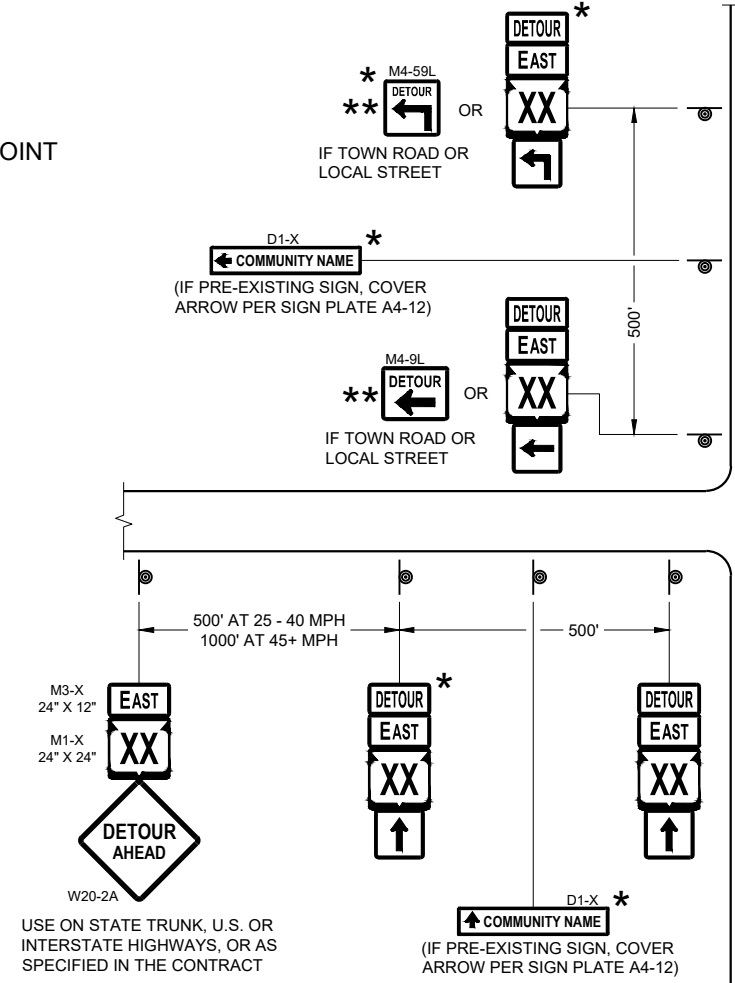

**DETAIL F  
DETOUR SIGNING**

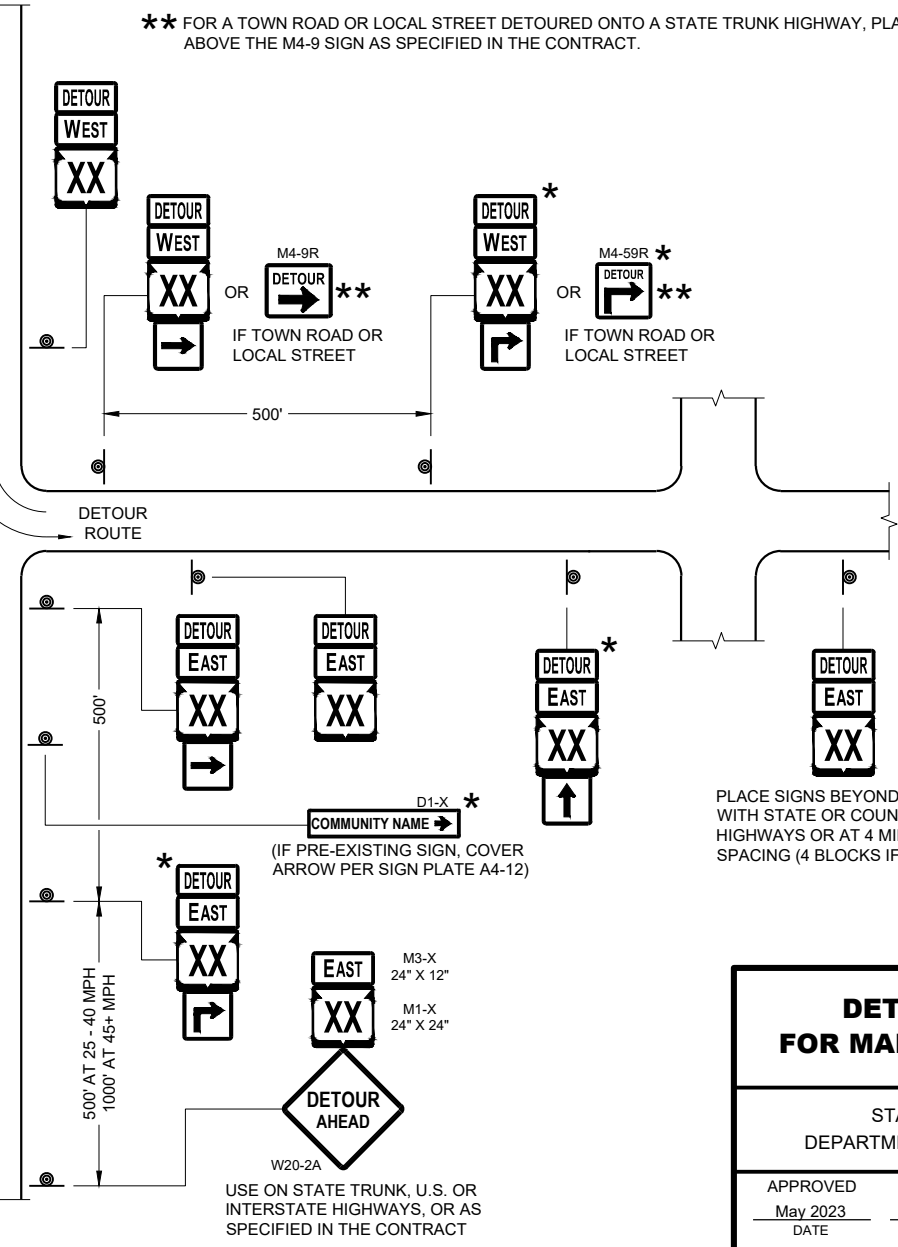

PLACE SIGNS BEYOND INTERSECTIONS WITH STATE OR COUNTY TRUNK HIGHWAYS OR AT 4 MILE MAXIMUM SPACING (4 BLOCKS IF URBAN AREA)

SEE SPECIFIC PROJECT DETOUR SIGNING DETAIL SHEETS AND DETAIL A OR B ON SDD SHEET 15C02 - SHEET "a"

DETOUR SIGNING FOR MAINLINE CLOSURES	
STATE OF WISCONSIN DEPARTMENT OF TRANSPORTATION	
APPROVED May 2023 DATE	/S/ Andrew Heidtke WORK ZONE ENGINEER
FHWA	



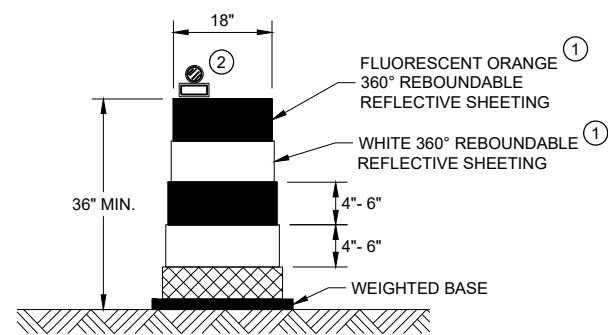

**DRUM**

BALLAST WIDTHS  
RANGE FROM 24"-36"

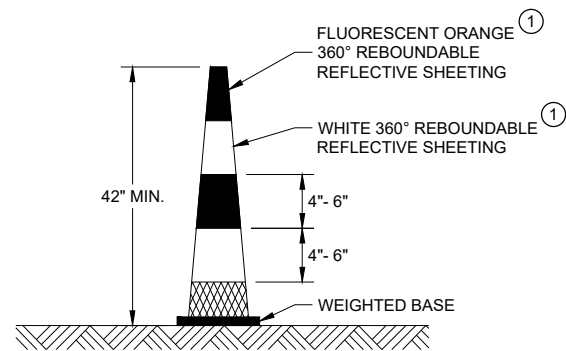

**42" CONE**

DO NOT USE IN TAPERS  
1/2 SPACING OF DRUMS  
BALLAST WIDTHS  
RANGE FROM 14"-20"

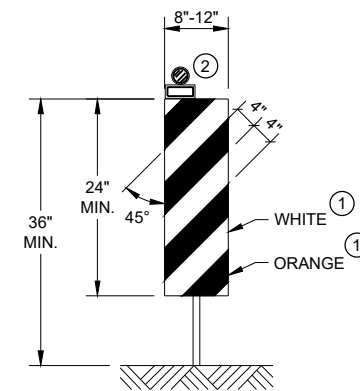

**VERTICAL PANEL**

THE STRIPES SHALL SLOPE DOWNWARD TO  
THE TRAFFIC SIDE FOR CHANNELIZATION.

**GENERAL NOTES**

- ① REFLECTIVE SHEETING SHALL FOLLOW THE REQUIREMENTS IN THE APPROVED PRODUCTS LISTING FOR SIGN SHEETING.
- ② LOCATION OF WARNING LIGHTS WHEN SHOWN ON THE PLAN.

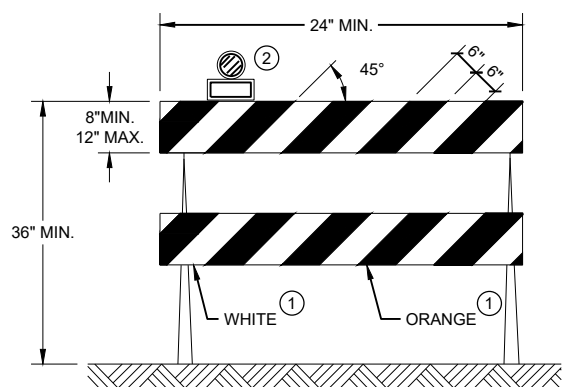

**TYPE II BARRICADE**

FOR RAILS LESS THAN 36" LONG, 4" WIDE STRIPES  
MAY BE USED. ALL STRIPES SHALL SLOPE DOWNWARD  
TO THE TRAFFIC SIDE FOR CHANNELIZATION.

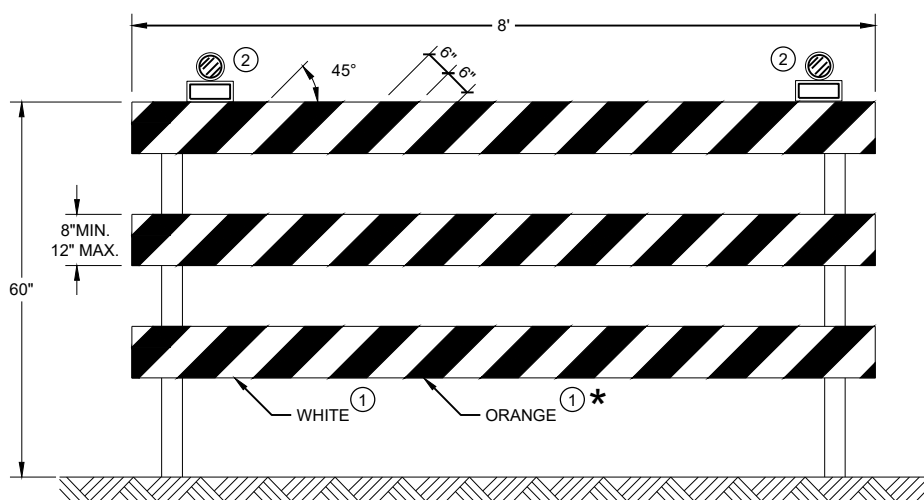

**TYPE III BARRICADE**

IF SIGN MOUNTED, DO NOT COVER MORE THAN 50% OF THE TOP  
TWO RAILS OR 33% OF THE TOTAL AREA OF THE THREE RAILS.

\* IF USED FOR A PERMANENT APPLICATION USE RED SHEETING.

<b>CHANNELIZING DEVICES DRUMS, CONES, BARRICADES AND VERTICAL PANELS</b>	
STATE OF WISCONSIN DEPARTMENT OF TRANSPORTATION	
APPROVED November 2022 DATE	/S/ Andrew Heidtke WORK ZONE ENGINEER
FHWA	

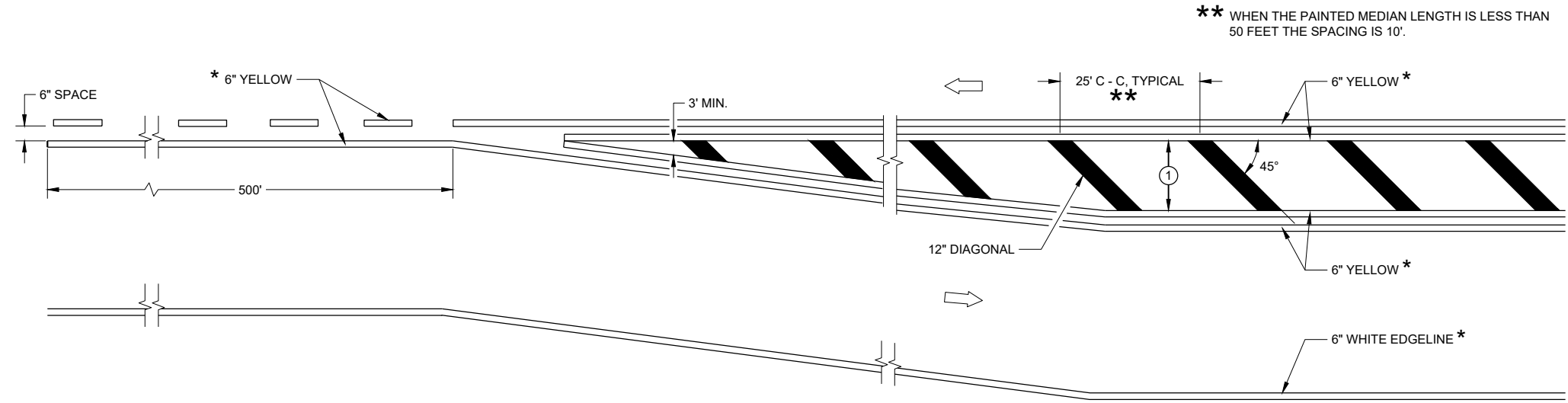

**MEDIAN ISLAND DETAIL**

**\*\*** WHEN THE PAINTED MEDIAN LENGTH IS LESS THAN 50 FEET THE SPACING IS 10'.

**GENERAL NOTES**

① DIAGONALS ARE OPTIONAL WHEN PAINTED ISLAND IS LESS THAN 6 FEET AT THE WIDEST POINT. OMIT DIAGONALS IF WIDTH IS LESS THAN 4 FEET.

➔ DIRECTION OF TRAVEL

\* CONFIRM MARKING LINE WIDTH WITH THE MISCELLANEOUS QUANTITIES

SPEED LIMIT	L
<35 MPH	5'
35> MPH	50'

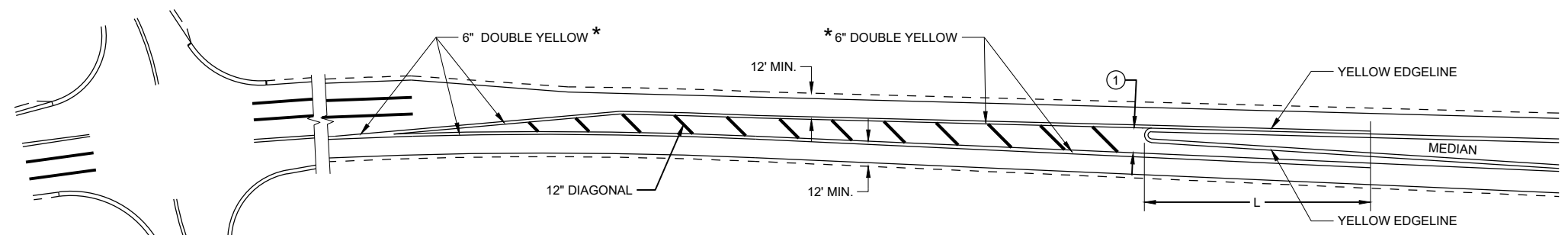

**APPROACH MARKINGS FOR OTHER MEDIAN TYPES**

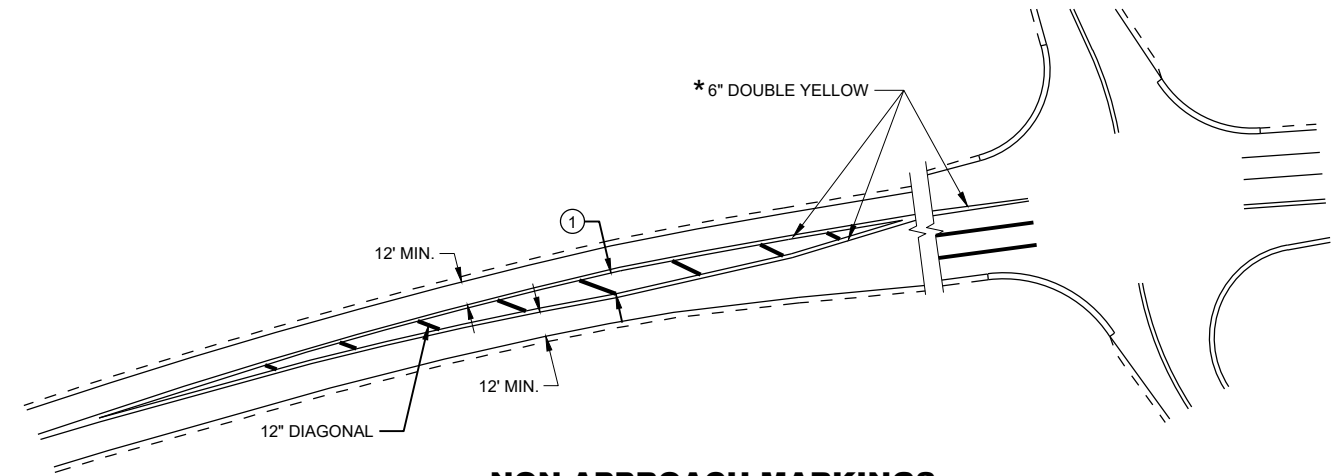

**NON-APPROACH MARKINGS**

6

6

SDD 15C18-08a

SDD 15C18-08a

<b>MEDIAN ISLAND PAVEMENT MARKINGS</b>	
STATE OF WISCONSIN DEPARTMENT OF TRANSPORTATION	
APPROVED May 2023 DATE	/S/ Jeannie Silver STATE SIGNING AND MARKING ENGINEER
FHWA	

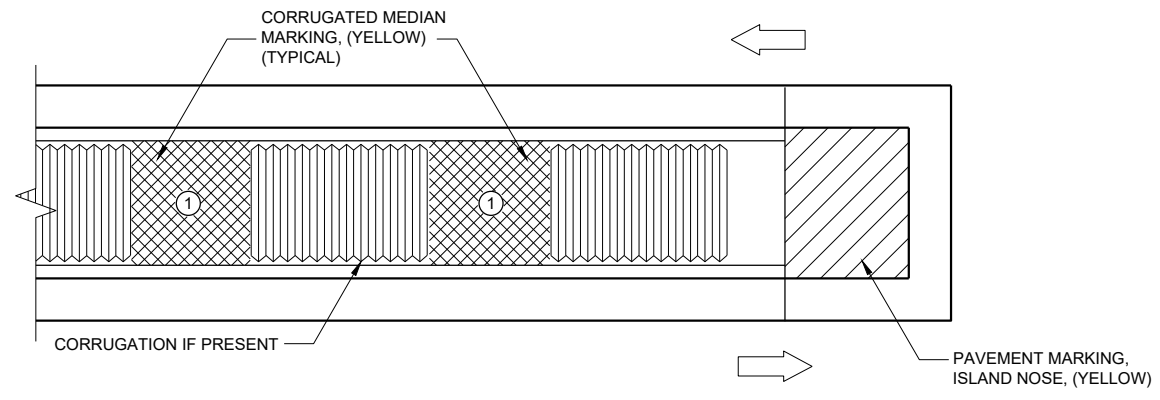

**MEDIAN ISLAND WITH SQUARE BLUNT NOSE**

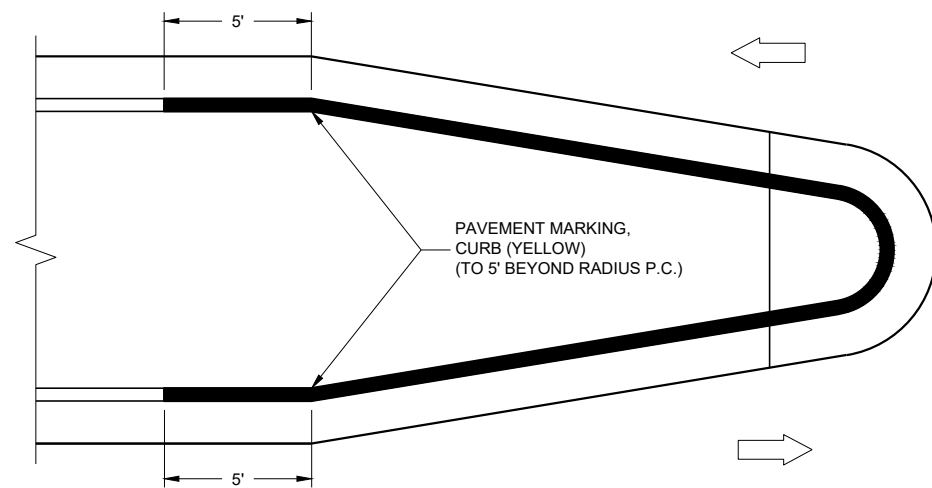

**MEDIAN ISLAND WITH ROUND BLUNT NOSE**

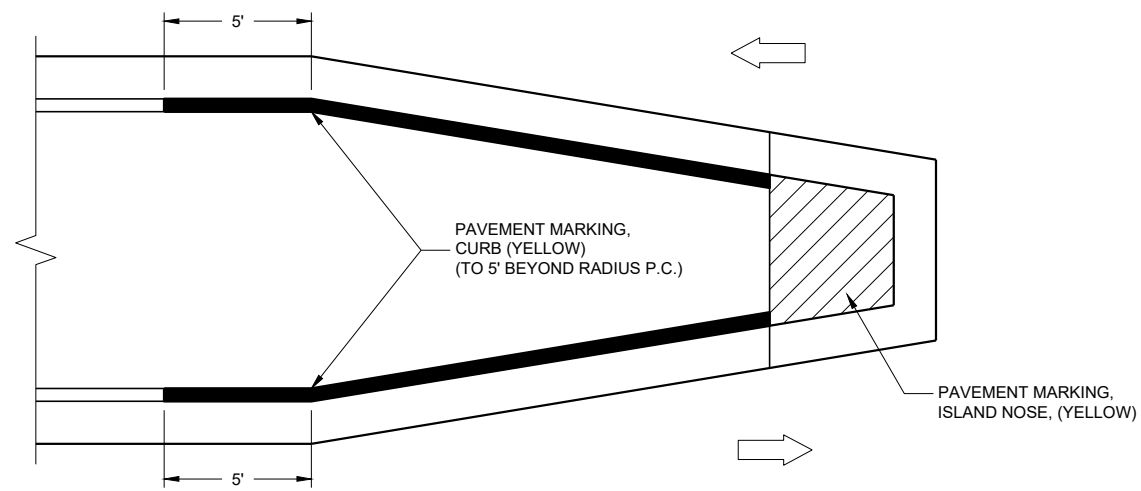





**MEDIAN ISLAND WITH SLOPED NOSE**

**TYPICAL PLACEMENT OF PAVEMENT MARKING ON MEDIAN ISLANDS**

**GENERAL NOTES**

WHEN CONCRETE CORRUGATED MEDIAN IS CONSTRUCTED TO SEPARATE TRAFFIC OPERATING IN THE OPPOSING DIRECTION, YELLOW PAVEMENT MARKING SHALL BE APPLIED TO THE FLAT PORTION OF THE CONCRETE CORRUGATED MEDIAN. THE ITEM OF PAVEMENT MARKING, CONCRETE CORRUGATED MEDIAN, WILL BE MEASURED IN PLACE AND ACCEPTED IN ACCORDANCE WITH THE CONTRACT AND PAID FOR AT THE CONTRACT UNIT PRICE PER SQUARE FOOT.

① APPLY PAVEMENT MARKING TO THE FLAT PORTION OF CORRUGATED MEDIAN.

-  ISLAND NOSE MARKING
-  CURB MARKING
-  CORRUGATED MEDIAN MARKING
-  DIRECTION OF TRAVEL

**PAVEMENT MARKINGS,  
MEDIAN ISLAND NOSE**

STATE OF WISCONSIN  
DEPARTMENT OF TRANSPORTATION

APPROVED  
May 2023 /S/ Jeannie Silver  
DATE STATE SIGNING AND MARKING  
ENGINEER

FHWA

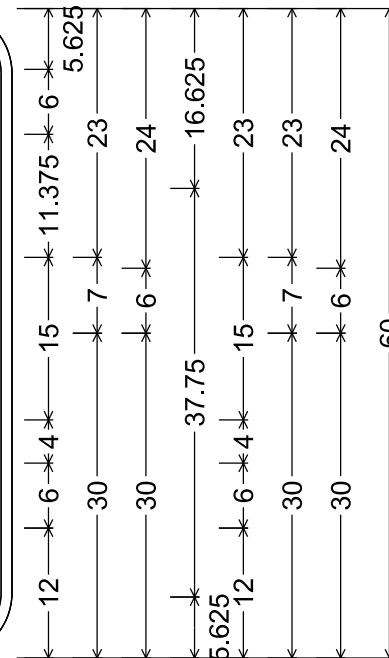
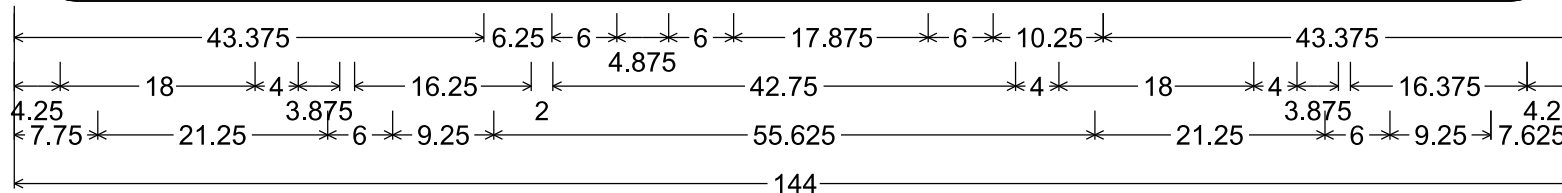
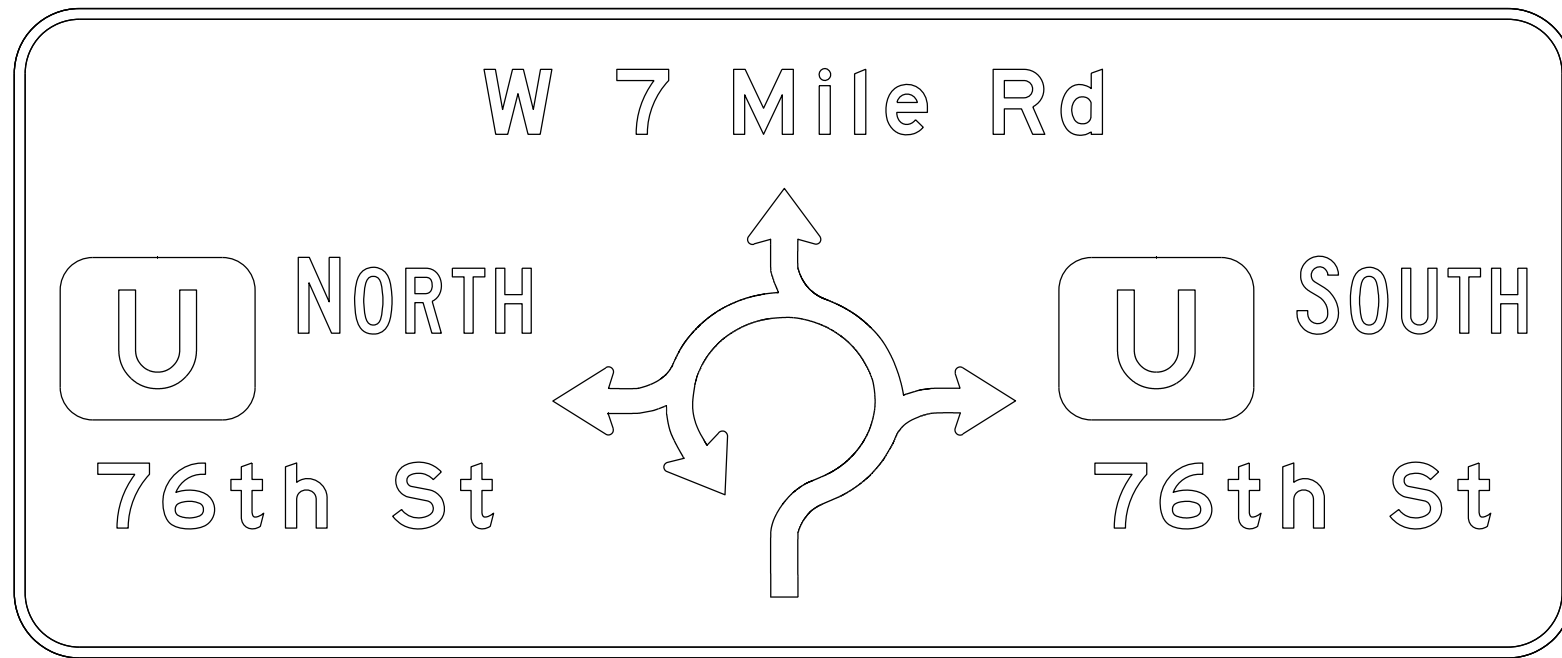

NOTES

1. All Signs Type II - Type H Reflective
2. Color:  
Background - Green  
Message - White
3. Message Series - E except as noted

D1-62; 6.000" Radius, 1.000" Border,  
"NORTH", C; "SOUTH", C

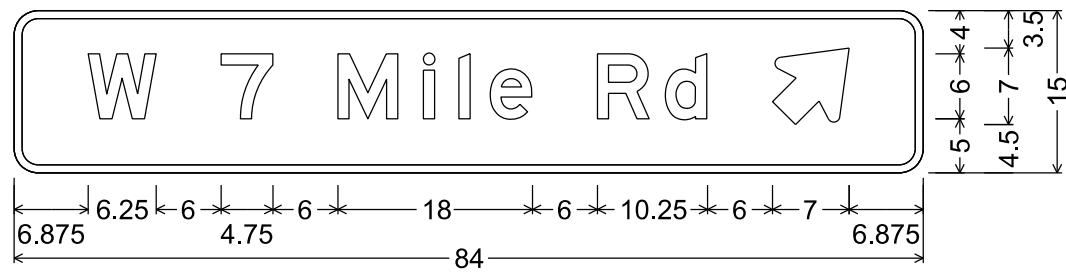

D1-1; 2.250" Radius, 0.750" Border

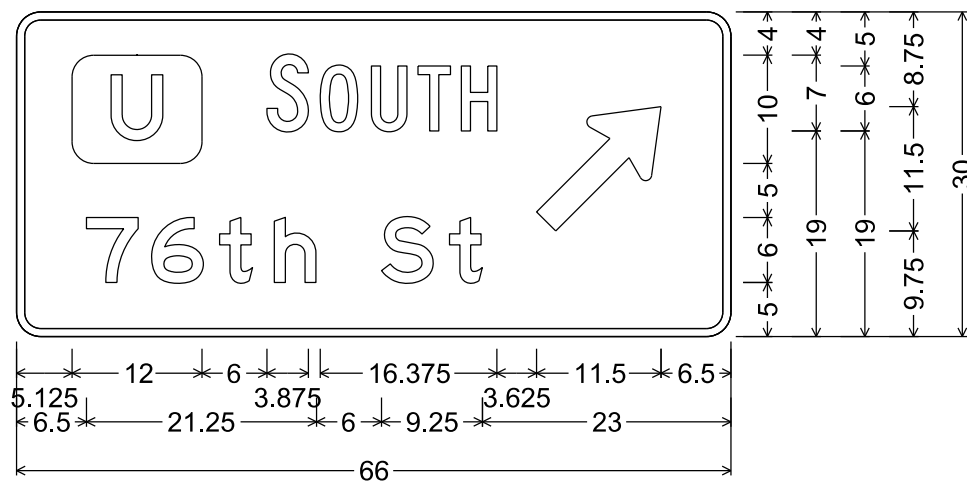

D1-2; 2.250" Radius, 0.750" Border,  
"SOUTH", C

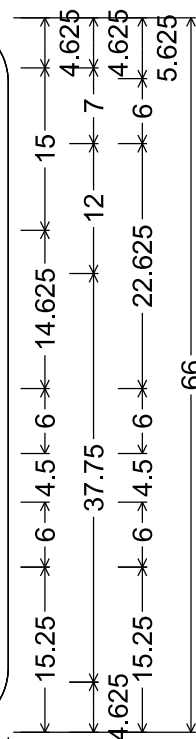
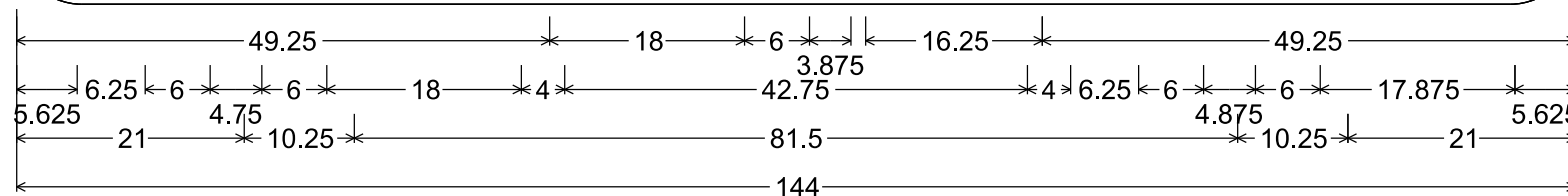
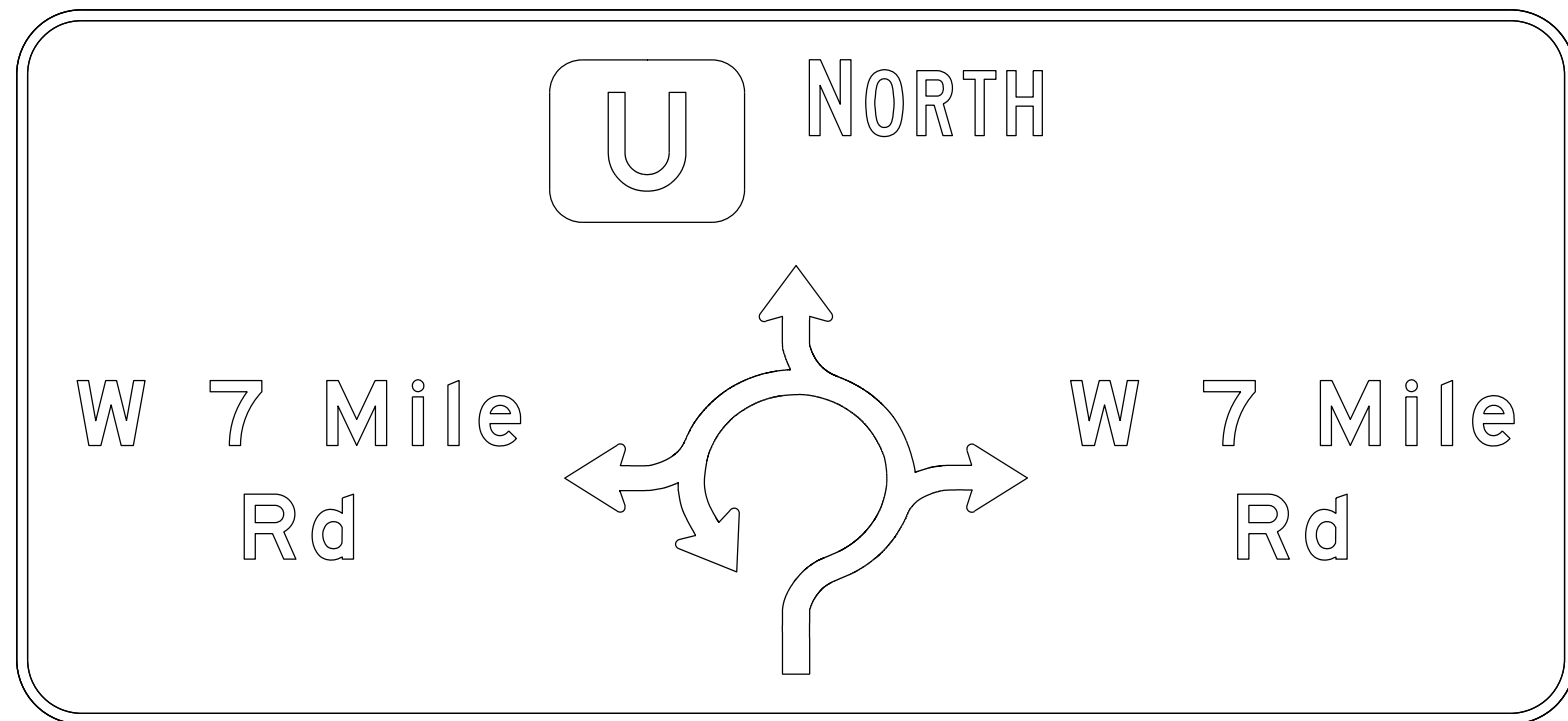

D1-62; 6.000" Radius, 1.000" Border,  
"NORTH", C

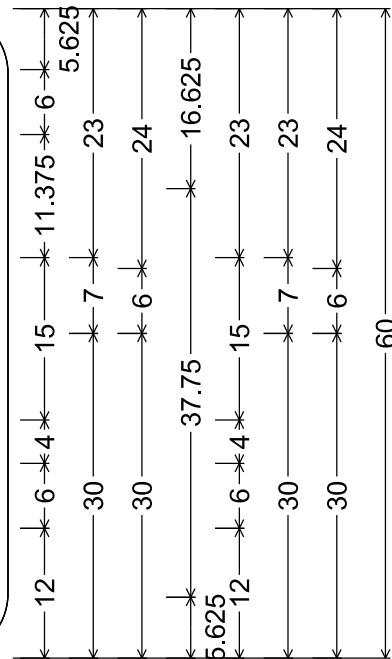
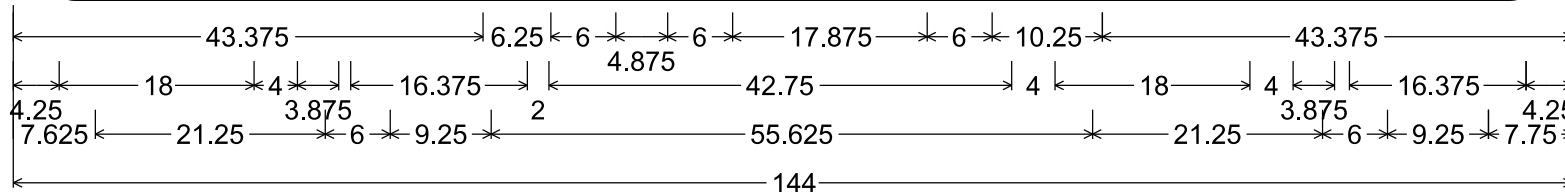
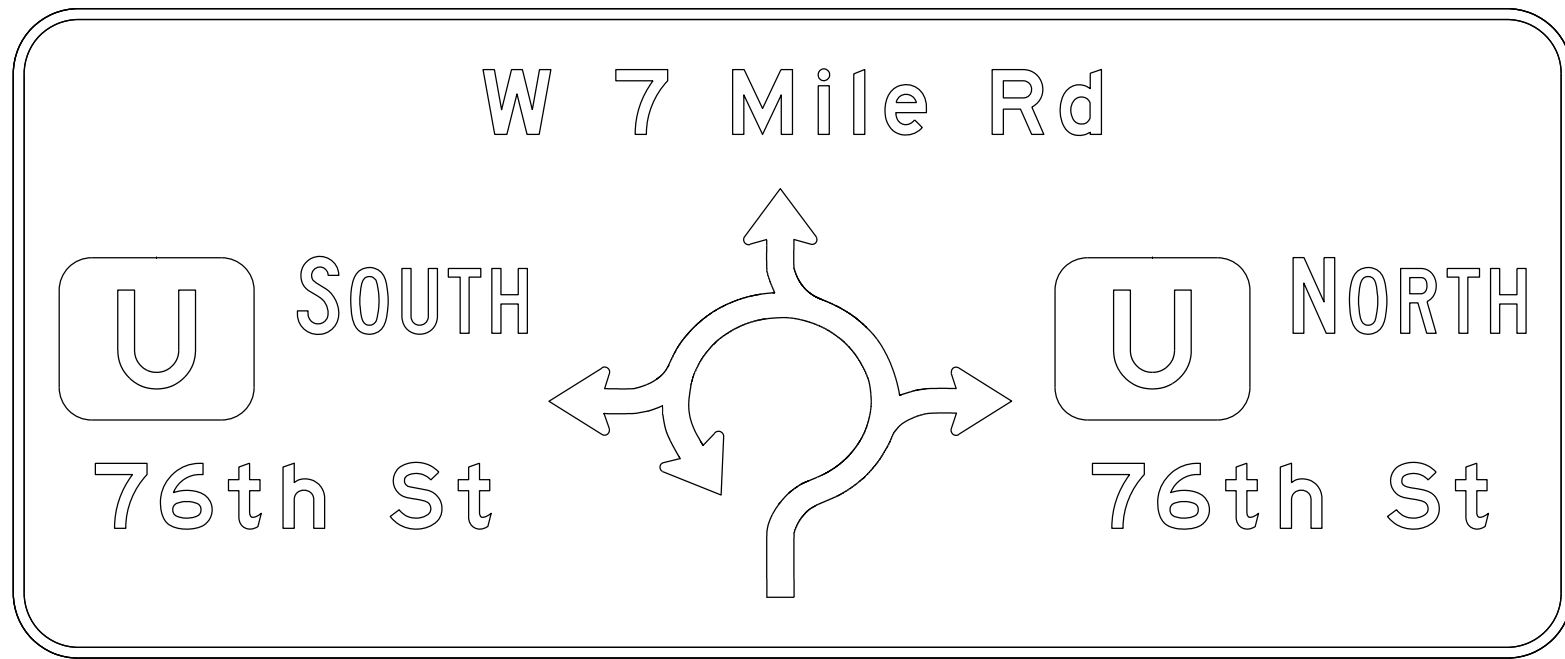

NOTES

1. All Signs Type II - Type H Reflective
2. Color:  
Background - Green  
Message - White
3. Message Series - E except as noted

D1-62; 6.000" Radius, 1.000" Border,  
"SOUTH", C; "NORTH", C

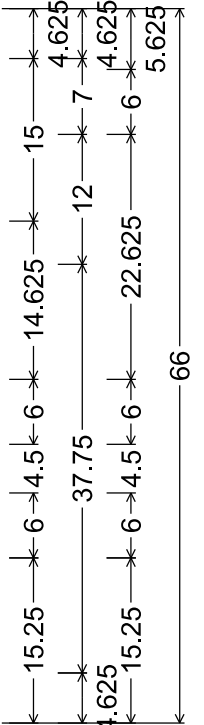
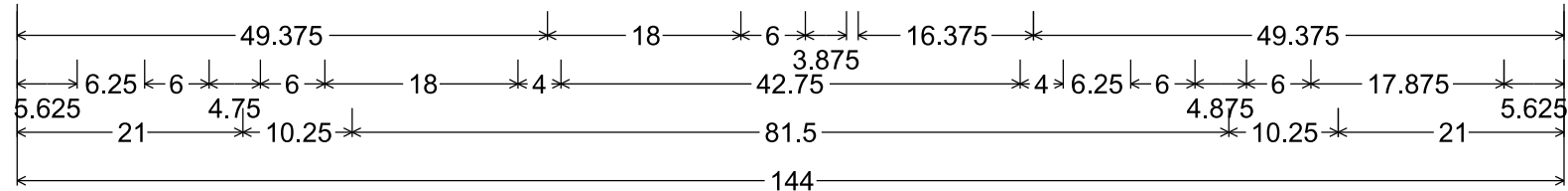
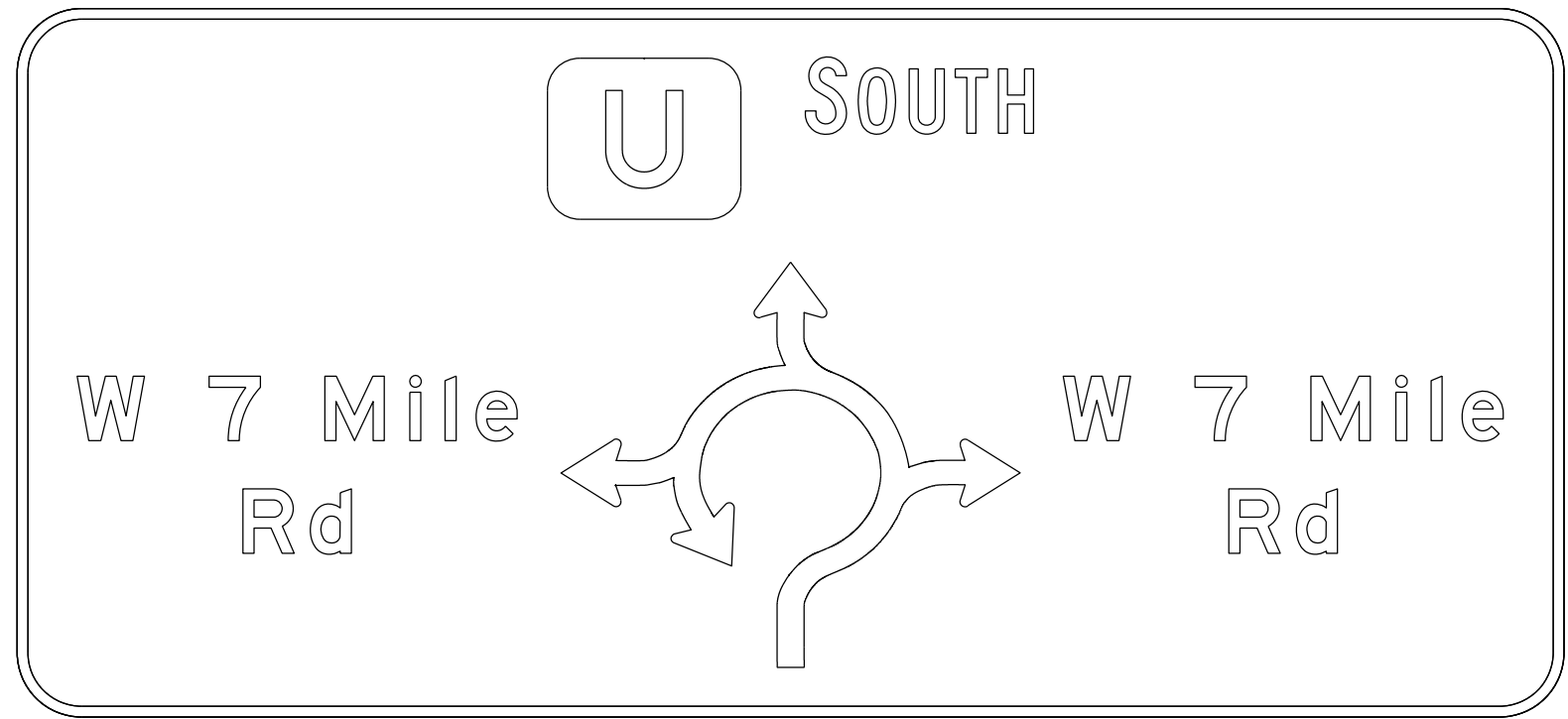

D1-62; 6.000" Radius, 1.000" Border,  
"SOUTH", C

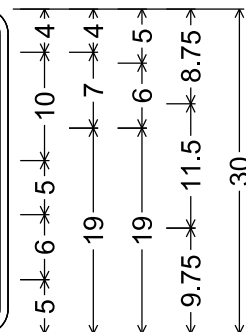
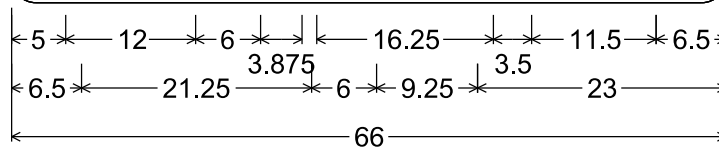

D1-2; 2.250" Radius, 0.750" Border,  
"NORTH", C

NOTES

1. Fixed Message Sign is Type II - Type F Reflective
2. Color:  
Background - Orange  
Message - Black
3. Message Series - C

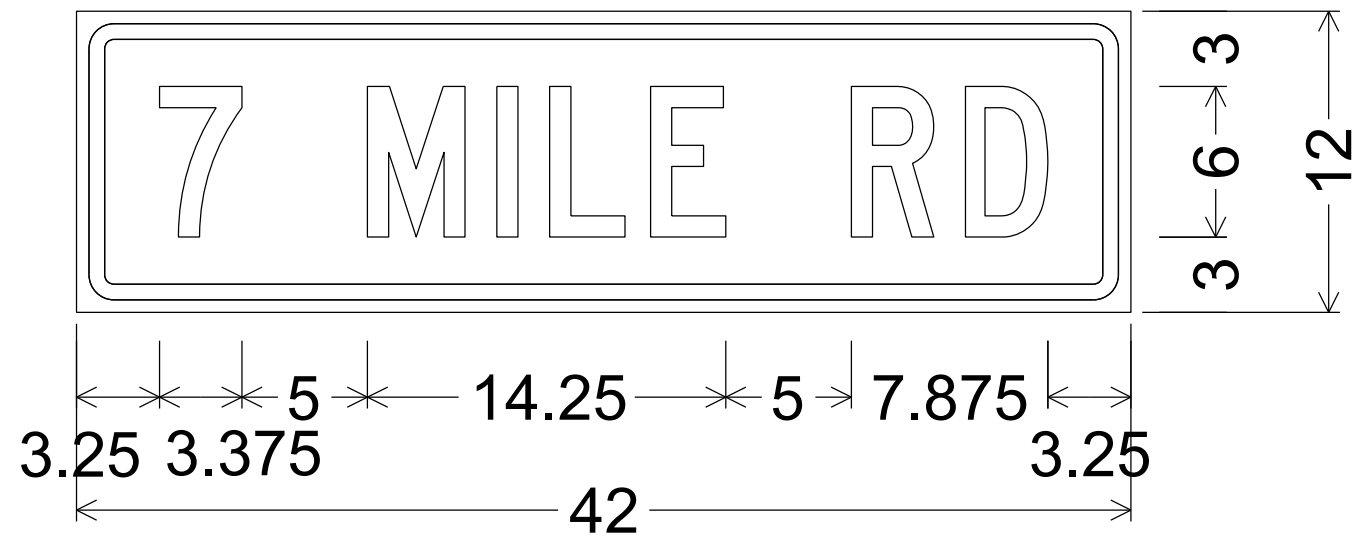

1.500" Radius, 0.625" Border, 0.500" Indent

7

7



# TYPICAL ASSEMBLIES

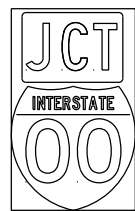

J1-1

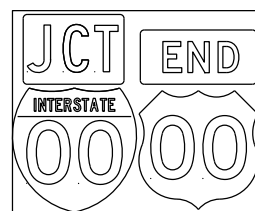

J1-2

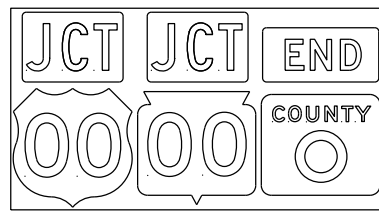

J1-3



JR1-1

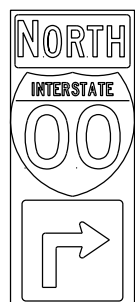

J2-1

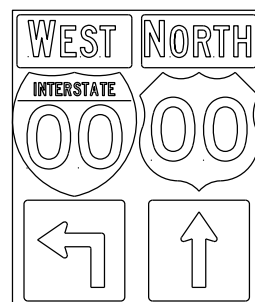

J2-2

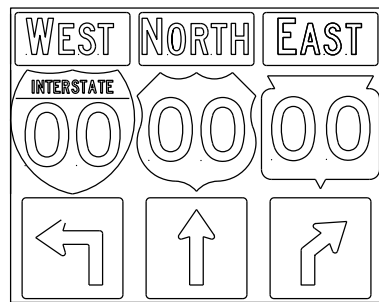

J2-3

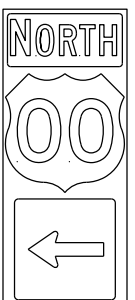

J3-1

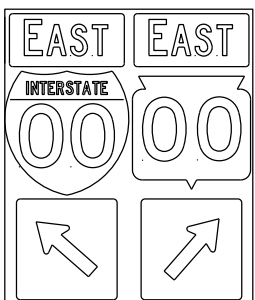

J3-2

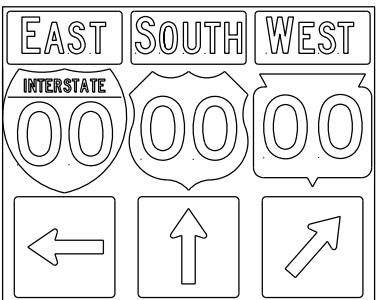

J3-3

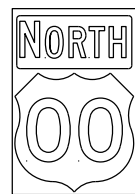

J4-1

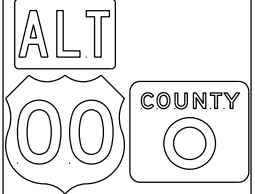

J4-2

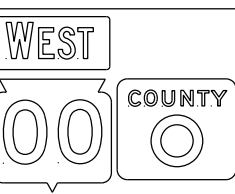

J4-2



J12-1

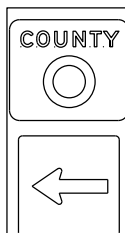

J13-1

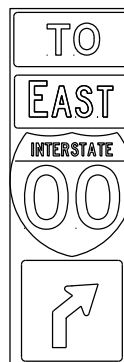

J32-1

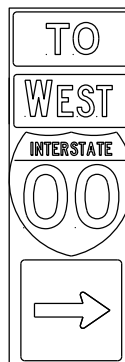

J33-1

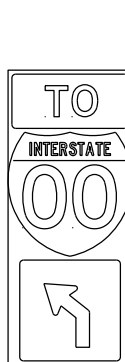

J22-1

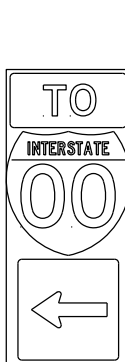

J23-1



JR13-1



JR23-1



JR99-1



JV

(Typical Vertical J-Assembly See Note 10 and 11)

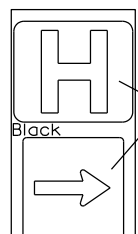

JH-1

Blue Background

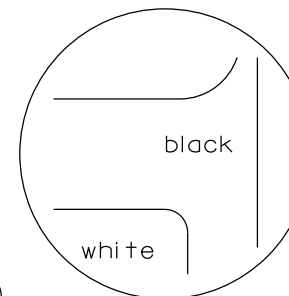
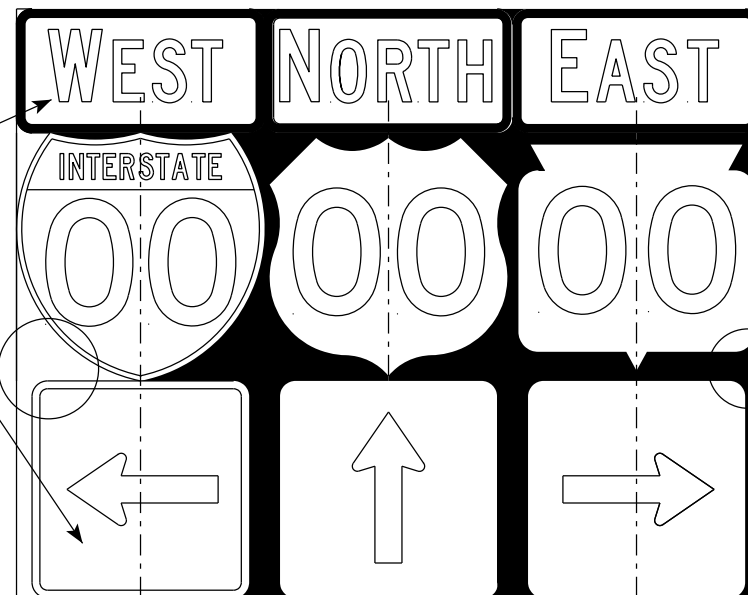
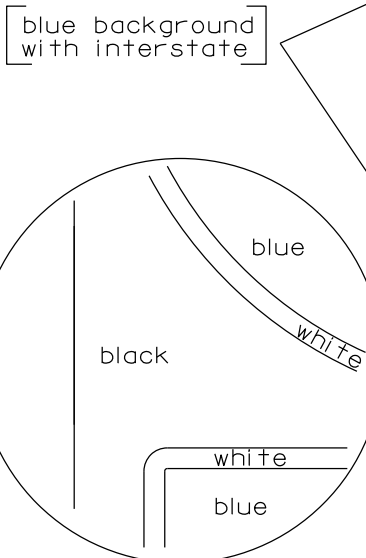

black background

## NOTES

- Signs are Type II - Type H Reflective
- Color:
  - Background - Black Non-reflective
  - Message - see Note 5
- Message Series - See Note 5
- Corners shall be square or rounded if base material is plywood. If base material is metal the corners shall be rounded.
- The colors and message spacing on each marker shall be according to the applicable route marker panel specifications.
- Certain marker heads require the component pieces to be the same color. As an example, all the components used with an MI-1 Interstate marker shall be blue.
- Single panel j-assemblies shall only be used with route marker shields that are same size. If the route marker shields are different size use multiple piece component.
- Route assemblies that have 24 inch route shields and have dimensions greater than 48 inches (both vertical and horizontal) shall have one horizontal splice between the arrows and route shields. Vertical splices shall not be used on route assemblies with a horizontal dimension of 144 inches or less. The contractor shall not use more than one vertical joint per sign and the joint shall be between route shields.
- Route assemblies that have 36 inch shields and have dimensions greater than 48 inches (both vertical and horizontal) shall have two horizontal splices. One horizontal splice shall be between the cardinal direction and route shields and the other horizontal splice shall be between the arrows and route shields. Vertical splices shall not be used on route assemblies with a horizontal dimension of 144 or less. The contractor shall not use more than one vertical joint per sign and the joint shall be between route shields.
- All Vertical J Assemblies are given a Sign Code of JV
- For JV Assemblies that have a mixture of Interstate and non Interstate shields, arrows and cardinals shall be white on blue.

### ROUTE MARKERS & COMPONENTS IN TYPICAL ASSEMBLIES

WISCONSIN DEPT OF TRANSPORTATION

APPROVED

*Matthew R. Rauch*  
for State Traffic Engineer

DATE 3/18/21

PLATE NO. A2-1S.9

PROJECT NO:

SHEET NO:

E

URBAN AREA

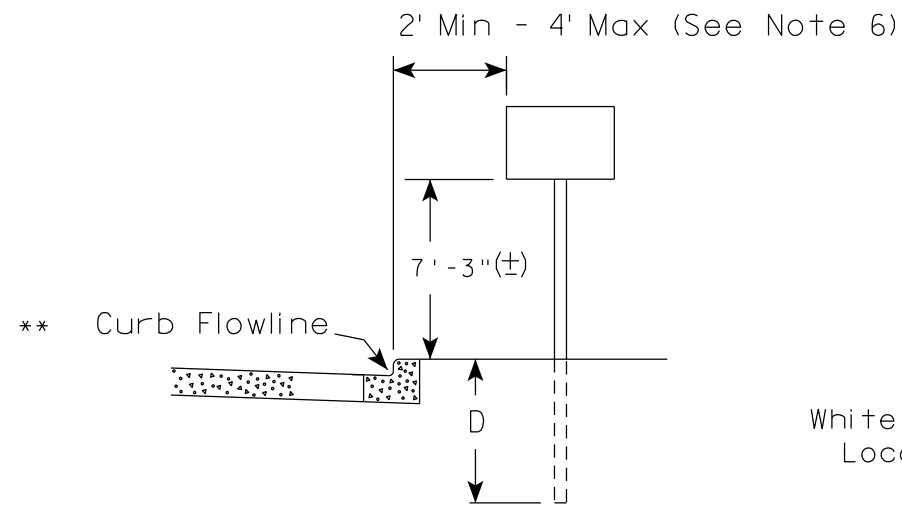

RURAL AREA (See Note 2)

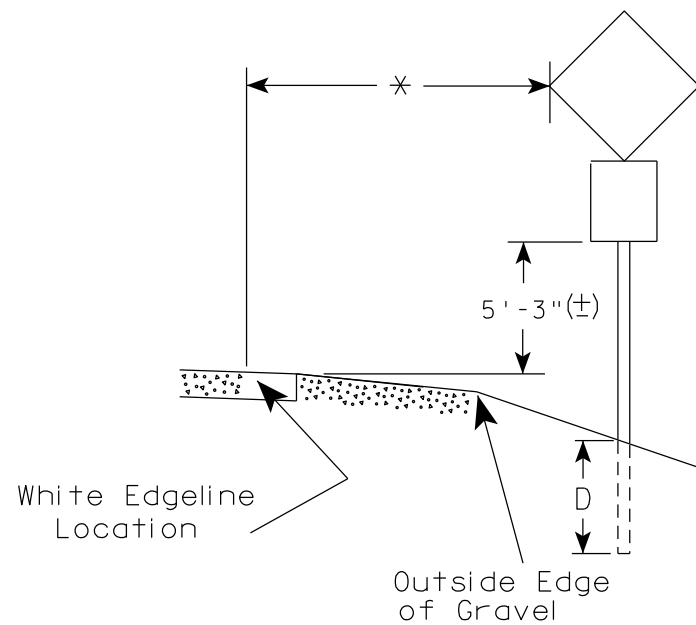
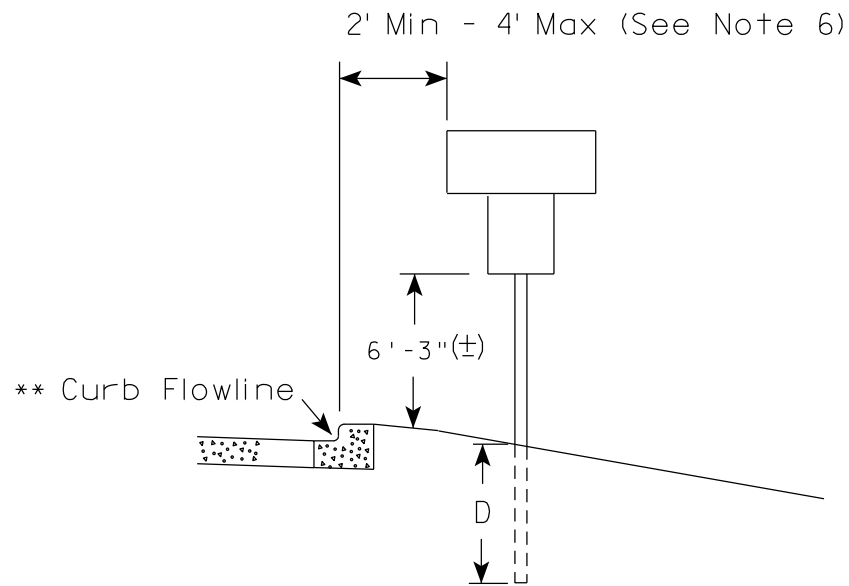
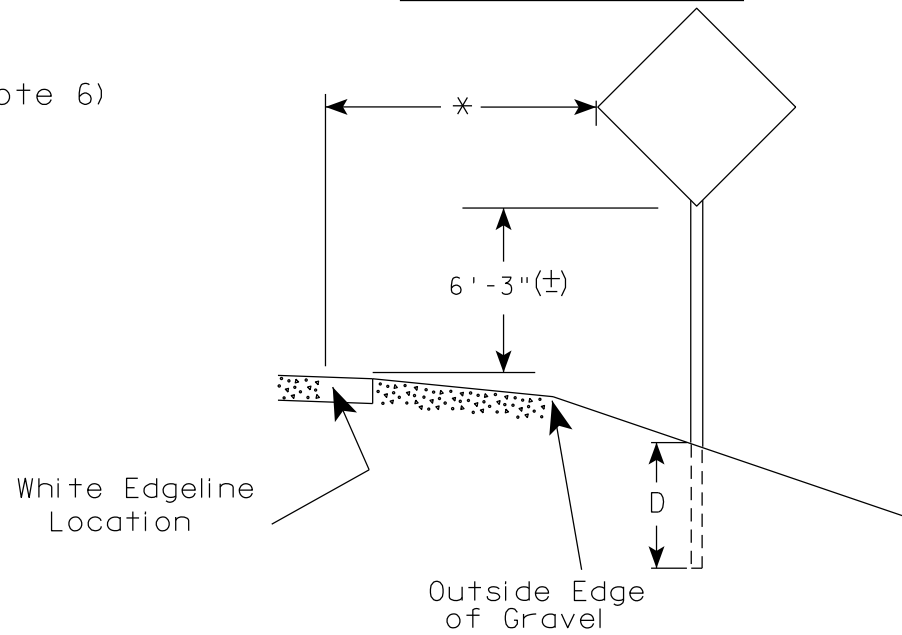

GENERAL NOTES

1. Signs wider than 4 feet or 20 sq.ft or larger, shall be mounted on multiple posts. Refer to plate A4-4.
2. If signs are mounted on or behind barrier wall, see A4-10 sign plate.  
The Double Arrow sign (W12-1D) shall be mounted at a height of 2'-3" (±). The Chevron sign (W1-8), Roundabout Chevron panel (R6-4B), Enhanced Reference Markers, Clearance Markers (W5-52), Mile Markers (D10 series), In Road Object Markers (W5-54) & End of Road Markers (W5-56) shall be mounted at a height of 4'-3" (±).
3. For expressways and freeways, mounting height is 7'- 3" (±) or 6'-3" (±) depending upon existence of a sub-sign.
4. Minimum mounting height for signs mounted on traffic signal poles is 5'- 3" (±).
5. Offset distance shall be consistent with existing signs or consistent throughout length of project.
6. The (±) tolerance for mounting height is 3 inches.
7. Folding signs shall be mounted at a height of 5'-3" (±) or as directed by the Engineer.

POST EMBEDMENT DEPTH

Area of Sign Installation ( Sq. Ft. )	D ( Min )
20 or Less	4'
Greater than 20	5'

\* \* The existence of curb and gutter does not in itself mandate the vertical clearance illustrated. That height is typically measured where there is sidewalk adjacent to the roadway or parking is permitted. In the absence of sidewalk vertical clearance is measured from the top of the curb. Offset of signs is measured from the flow line.

\* 6 feet from edge of a paved shoulder or 12 feet from the edge of pavement (edge line location) or 2 feet from outside edge of gravel, whichever is greater unless directed by project engineer.

TYPICAL INSTALLATION OF PERMANENT TYPE II SIGNS ON SINGLE POSTS

WISCONSIN DEPT OF TRANSPORTATION

APPROVED *Matthew R. Rauch*  
for State Traffic Engineer

DATE 5/13/2020 PLATE NO. A4-3.22

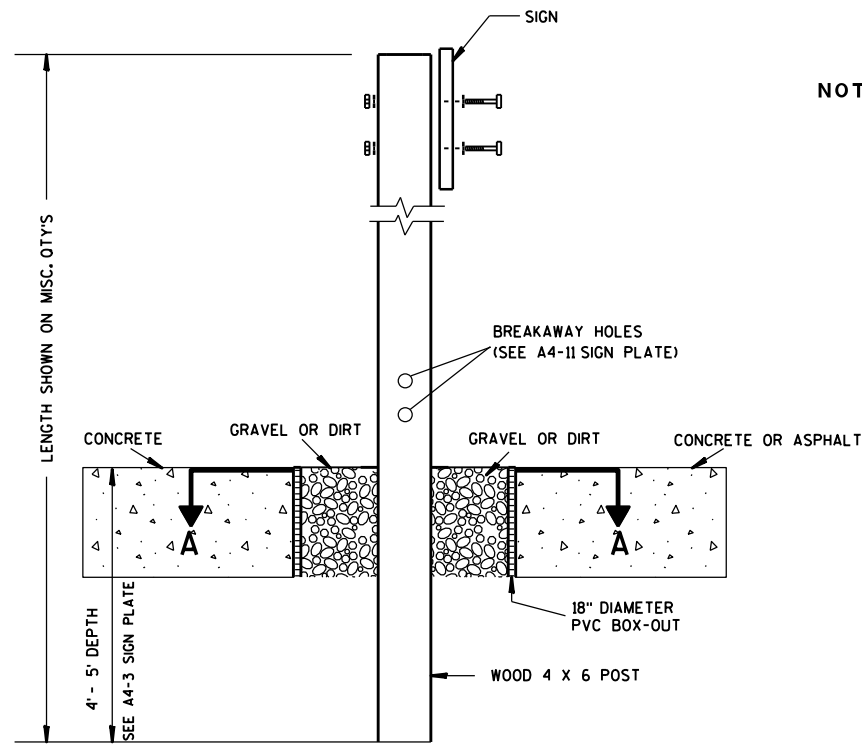

**ELEVATION VIEW**

**DETAIL OF WOOD 4 X 6 SIGN POST IN BOX-OUT**

- NOTES:**
1. ALL MATERIAL TO BE APPROVED BY ENGINEER PRIOR TO INSTALLATION
  2. SEE SIGN PLATE A4-8 FOR SIGN HARDWARE REQUIREMENTS
  3. 18 INCH X 18 INCH SQUARE BOX-OUTS MAY BE USED FOR INSTALLATIONS IN EXISTING CONCRETE OR ASPHALT LOCATIONS.

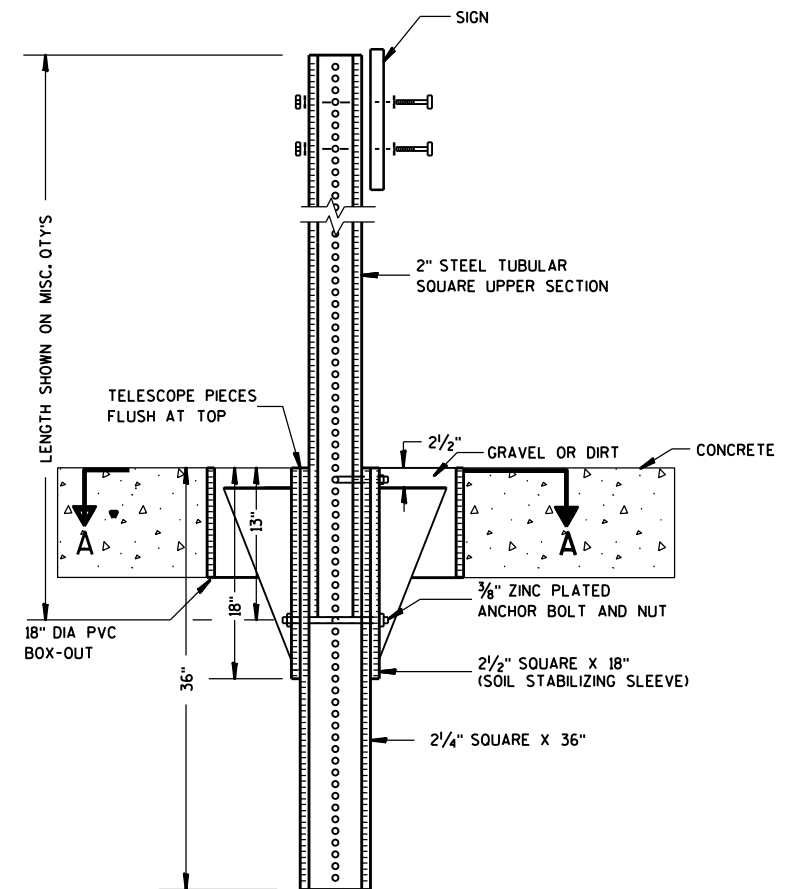

**ELEVATION VIEW**

**DETAIL OF STEEL 2 X 2 SIGN POST IN BOX-OUT**

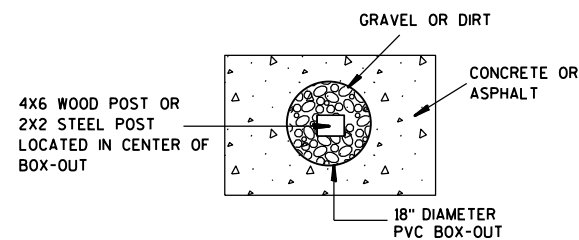

**PLAN VIEW**

**FOR NEW CONCRETE/ ASPHALT INSTALLATIONS**

**SIGN POST  
BOX-OUTS  
A4-3B**

WISCONSIN DEPT OF TRANSPORTATION

APPROVED *Matthew R. Rauch*  
for State Traffic Engineer

DATE 1/27/14 PLATE NO. A4-3B.1

7

7

GENERAL NOTES

1. For 3 or 4 post installations, individual post spacing shall be greater than 3'-6".
2. See tables below for required number of posts.
3. For expressways and freeways, mounting height is 7'-3" (±) or 6'-3" (±) depending upon existence of sub-sign.
4. The (±) tolerance for mounting height is 3 inches.
5. J-Assemblies are considered to be one sign for mounting height.
6. Offset distance shall be consistent with existing signs or consistent throughout length of project.
7. Folding signs shall be mounted at a height of 5'-3" (±) or as directed by the engineer.
8. The Double Arrow sign (W12-1) shall be mounted at a height of 2'-3" (±). The Chevron sign (W1-8), Roundabout Chevron panel (R6-4B), Clearance Markers (W5-52), Mile Markers (D10 series), In Road Object Markers (W5-54) & End of Road Markers (W5-56) shall be mounted at a height of 4'-3" (±).

URBAN AREA

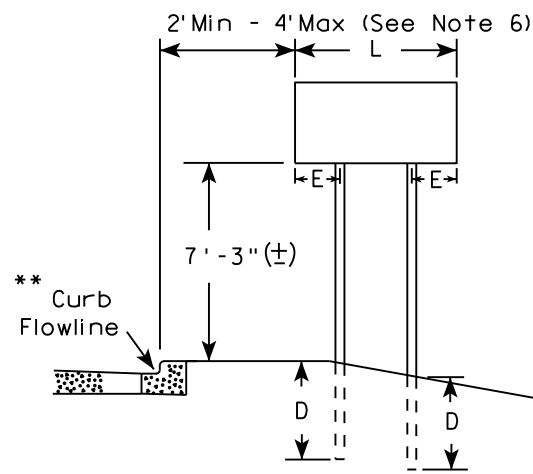

RURAL AREA (See Note 3)

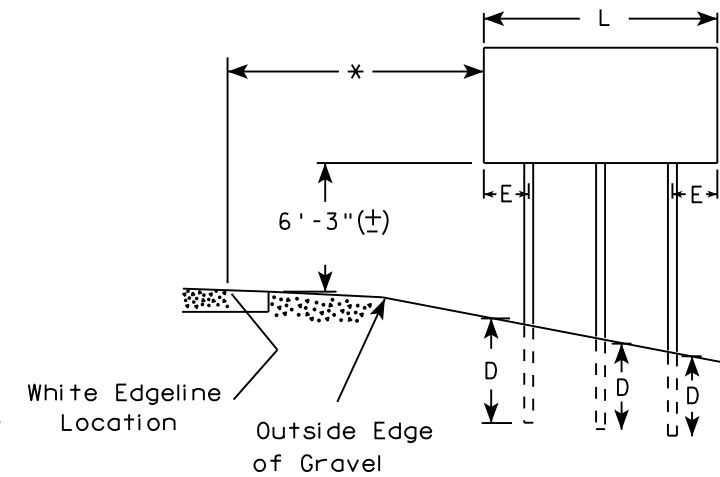
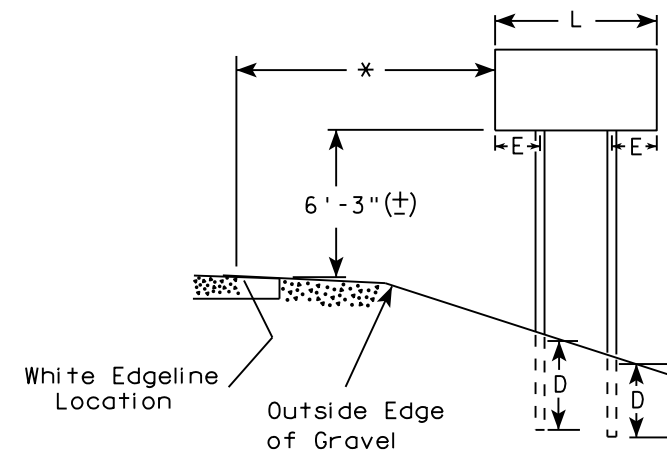

2' Min - 4' Max (See Note 6)

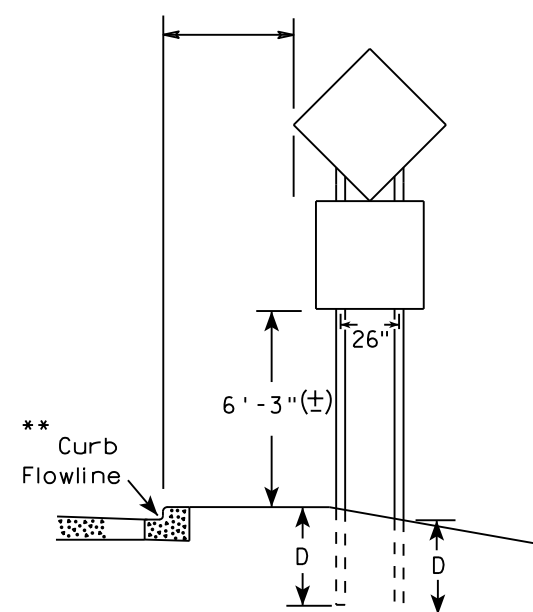

48" DIAMOND WARNING SIGN

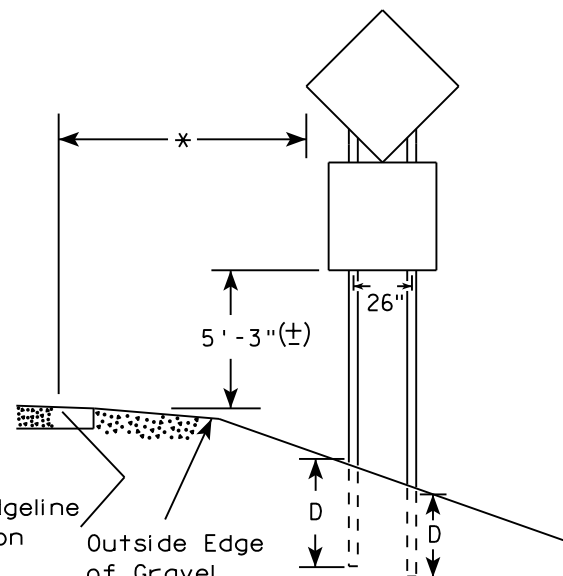

48" DIAMOND WARNING SIGN

\* 6 feet from edge of a paved shoulder or 12 feet from the edge of pavement (edge line location) or 2 feet from outside edge of gravel, whichever is greater unless directed by project engineer.

\*\* The existence of curb and gutter does not in itself mandate the vertical clearance illustrated. That height is typically measured where there is sidewalk adjacent to the roadway or parking is permitted. In the absence of sidewalk vertical clearance is measured from the top of the curb. Offset of signs is measured from the flow line.

\*\*\* See A4-3 sign plate for signs 4' or less in width and less than 20 S.F. in area.

SIGN SHAPE OTHER THAN DIAMOND (TWO POSTS REQUIRED)	
L	E
Greater than 48" Less than 60"	12"
60" to 108"	L/5

\*\*\*

SIGN SHAPE OTHER THAN DIAMOND (THREE POSTS REQUIRED)	
L	E
Greater than 108" to 144"	12"

POST EMBEDMENT DEPTH

Area of Sign Installation ( Sq. Ft. )	D ( Min )
20 or Less	4'
Greater than 20	5'

TYPICAL INSTALLATION OF TYPE II SIGNS ON MULTIPLE POSTS

WISCONSIN DEPT OF TRANSPORTATION  
 APPROVED *Matthew R. Rauch*  
 For State Traffic Engineer  
 DATE 8/21/17 PLATE NO. A4-4.15

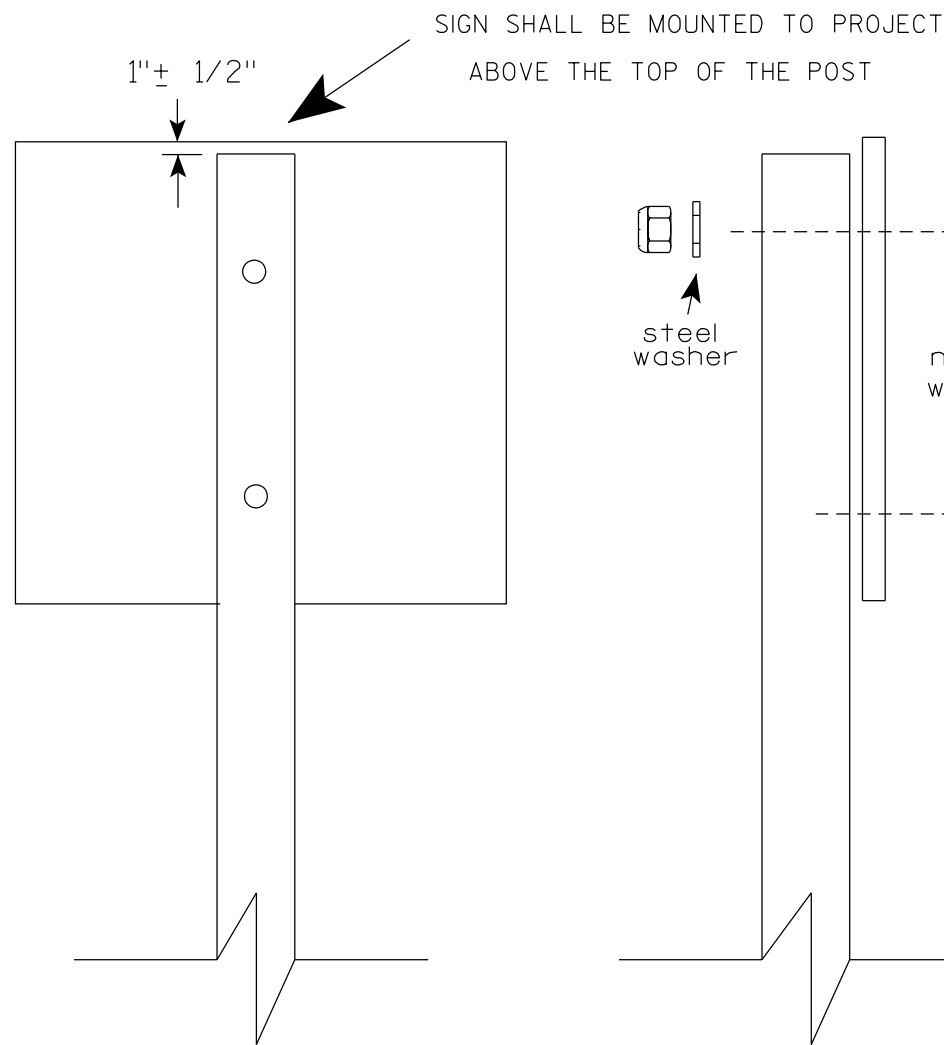

Nuts, bolts and lags used for mounting signs shall have hexagonal heads and shall be either :

- Hot dip galvanized in accordance with ASTM Designation: A 153, Class D, or SC 3
- Electro-galvanized in accordance with ASTM Designation : B 633, TYPE III, SC 3.

Threads on bolts and nuts shall be manufactured with sufficient allowance for the cadmium plate or galvanized coating to permit the nuts to run freely on the bolts.

- STRINGER BOLTING TO ALUMINUM SIGNS (SEE SIGN PLATE A4-18)
- MACHINE BOLTS -  $\frac{5}{16}$ " X 1-3/4" Length w/ lock nuts
- WOOD POSTS (4" x 6")
- LAG SCREWS -  $\frac{3}{8}$ " X 3" (NO STRINGERS ON BACK OF SIGN)  
 $\frac{3}{8}$ " X 4" (STRINGERS ON BACK OF SIGN)
- SQUARE STEEL POSTS (2" x 2")
- MACHINE BOLTS -  $\frac{3}{8}$ " X 3-1/4" Length w/ nuts (NO STRINGER ON BACK OF SIGN)  
 $\frac{3}{8}$ " X 5" Length w/ nuts (STRINGERS ON BACK OF SIGN)
- RIVETS -  $\frac{9}{32}$ " (6605-9-6) BULB-TITE, TRI-FOLD, ALUMINUM BODY/MANDREL  
 O.D. FLANGE .720-.765 INCH, GRIP RANGE .042-.375 INCH
- WASHERS (ALL POSTS) -
- 1-1/4" O.D. X  $\frac{3}{8}$ " I.D. X  $\frac{1}{16}$ " STEEL
- 1-1/4" O.D. X  $\frac{3}{8}$ " I.D. X .080 NYLON

\* Two different fastening systems are shown for illustration purposes. On any individual sign, either one or the other system shall be used. Actual number of fasteners per sign varies with the sign area, but normally there are two. For a single post installation, all signs greater than 9 sq. ft. require the use of 3 fasteners.

ATTACHMENT OF SIGNS TO POSTS	
WISCONSIN DEPT OF TRANSPORTATION	
APPROVED	<i>Matthew R Rauch</i> For State Traffic Engineer
DATE 4/1/2020	PLATE NO. A4-8.9

**TELESCOPIC TUBING ANCHORS  
TWO PIECE SYSTEM**

2 1/4" SQUARE  
12 GAUGE  
PERFORATED  
GALVANIZED FINISH

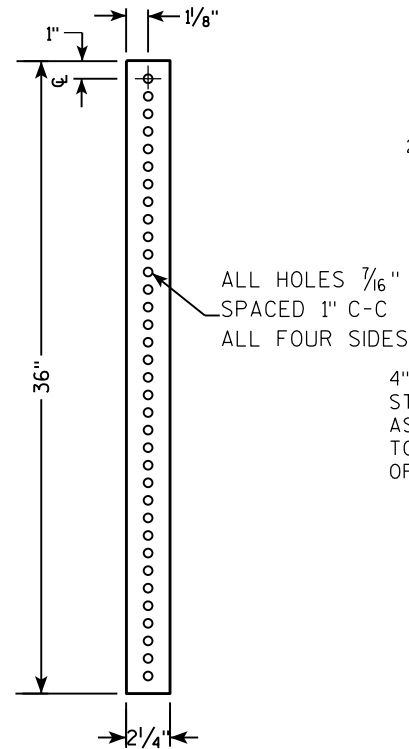

2 1/2" SQUARE  
12 GAUGE  
OMNI-DIRECTIONAL  
PERFORATED  
SOIL STABILIZING SLEEVE  
GALVANIZED FINISH

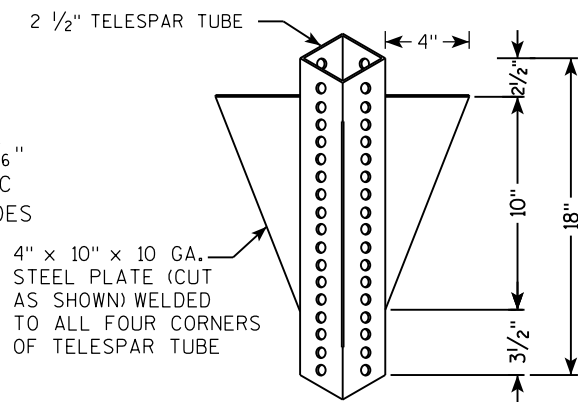

**DETAIL OF TUBULAR STEEL SIGN POST  
(IN POURED CONCRETE OR ASPHALT)**

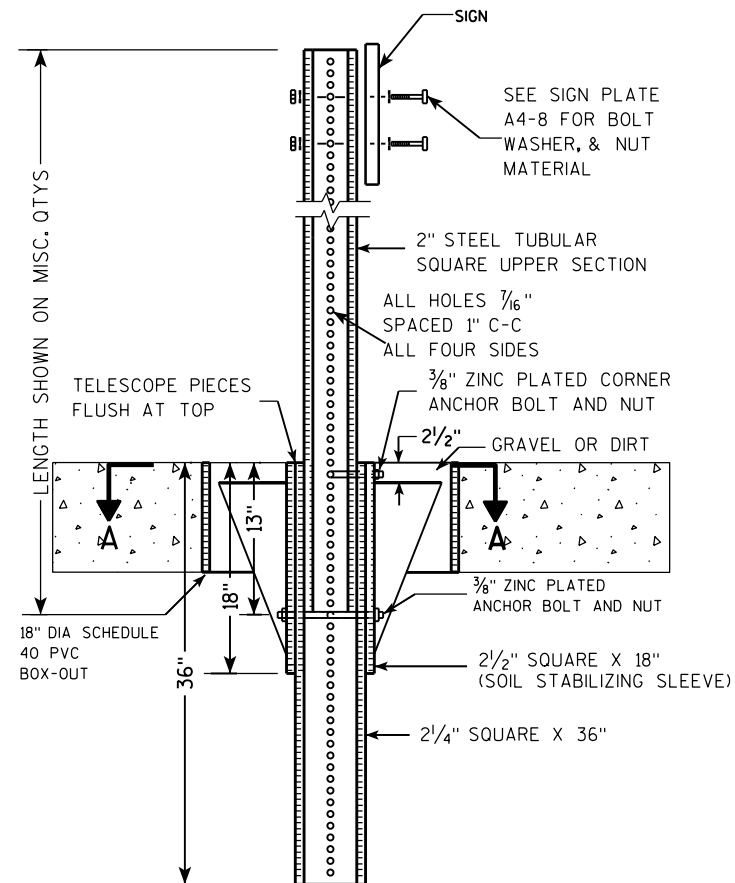

**DETAIL OF TUBULAR STEEL SIGN POST  
(IN LOCATIONS OTHER THAN POURED CONCRETE OR ASPHALT)**

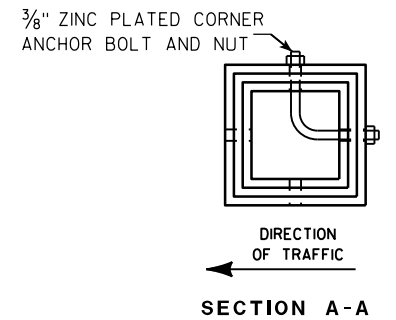
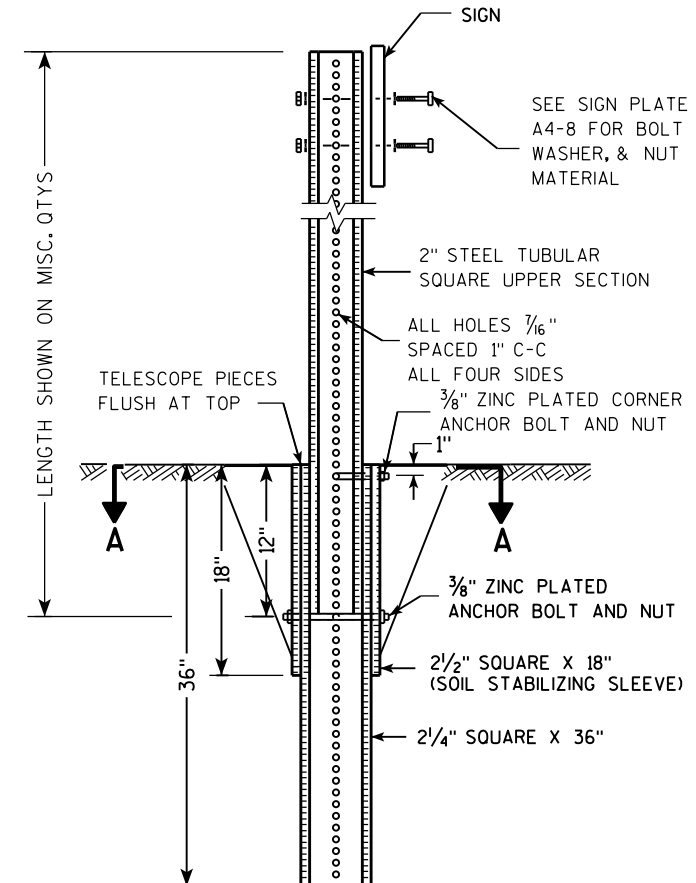

Area of Sign Installation (Sq. Ft.)	Number of Required Posts
9 or less	1
Greater than 9 less than or equal to 18	2
Greater than 18 less than or equal to 27	3

Signs wider than 3 feet or larger than 9 sq. ft shall be mounted on multiple posts (see above table).

**TUBULAR STEEL  
SIGN POST  
A4-9**

WISCONSIN DEPT OF TRANSPORTATION

APPROVED *Matthew R. Rauch*  
for State Traffic Engineer

DATE 2/05/15 PLATE NO. A4-9.9

PROJECT NO:

HWY:

COUNTY:

SHEET NO:

E

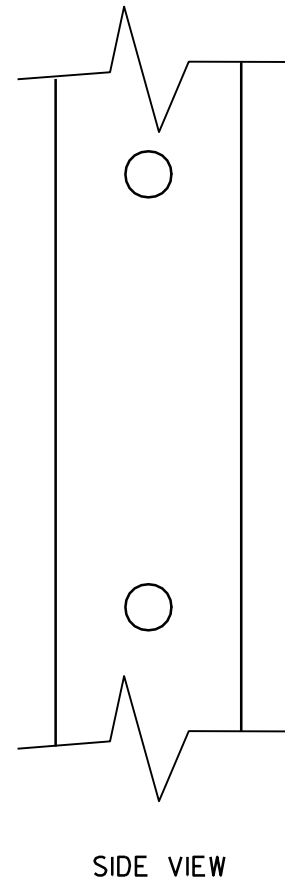
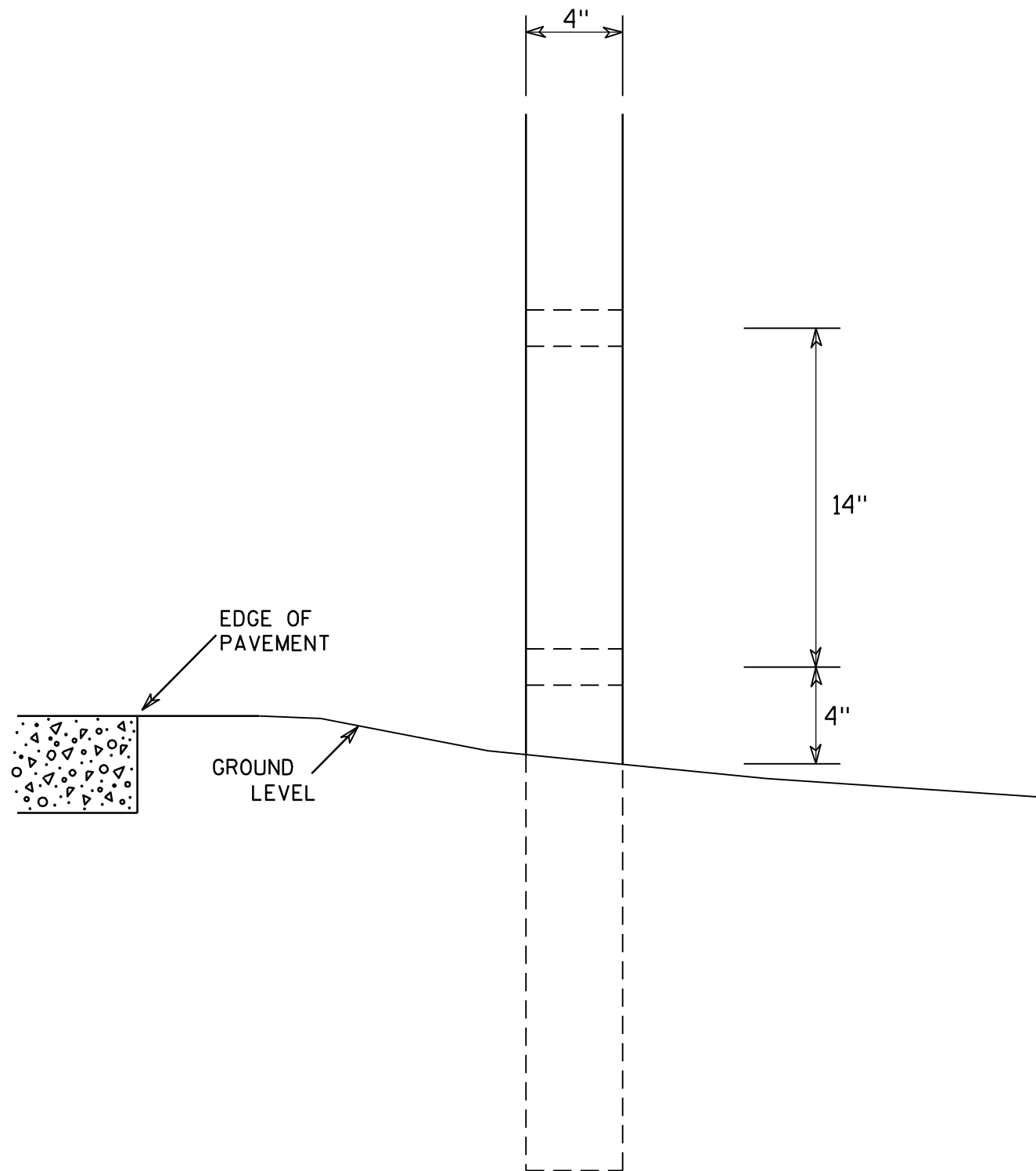

GENERAL NOTES

1. All 4 x 6 Wood Posts shall be modified by having two 1½" diameter holes drilled perpendicular to the roadway centerline.

7

7

<b>4 X 6 WOOD POST MODIFICATIONS</b>	
<i>WISCONSIN DEPT OF TRANSPORTATION</i>	
APPROVED	<i>Chester J Spang</i> for State Traffic Engineer
DATE <u>3/27/97</u>	PLATE NO. <u>A4-11.2</u>

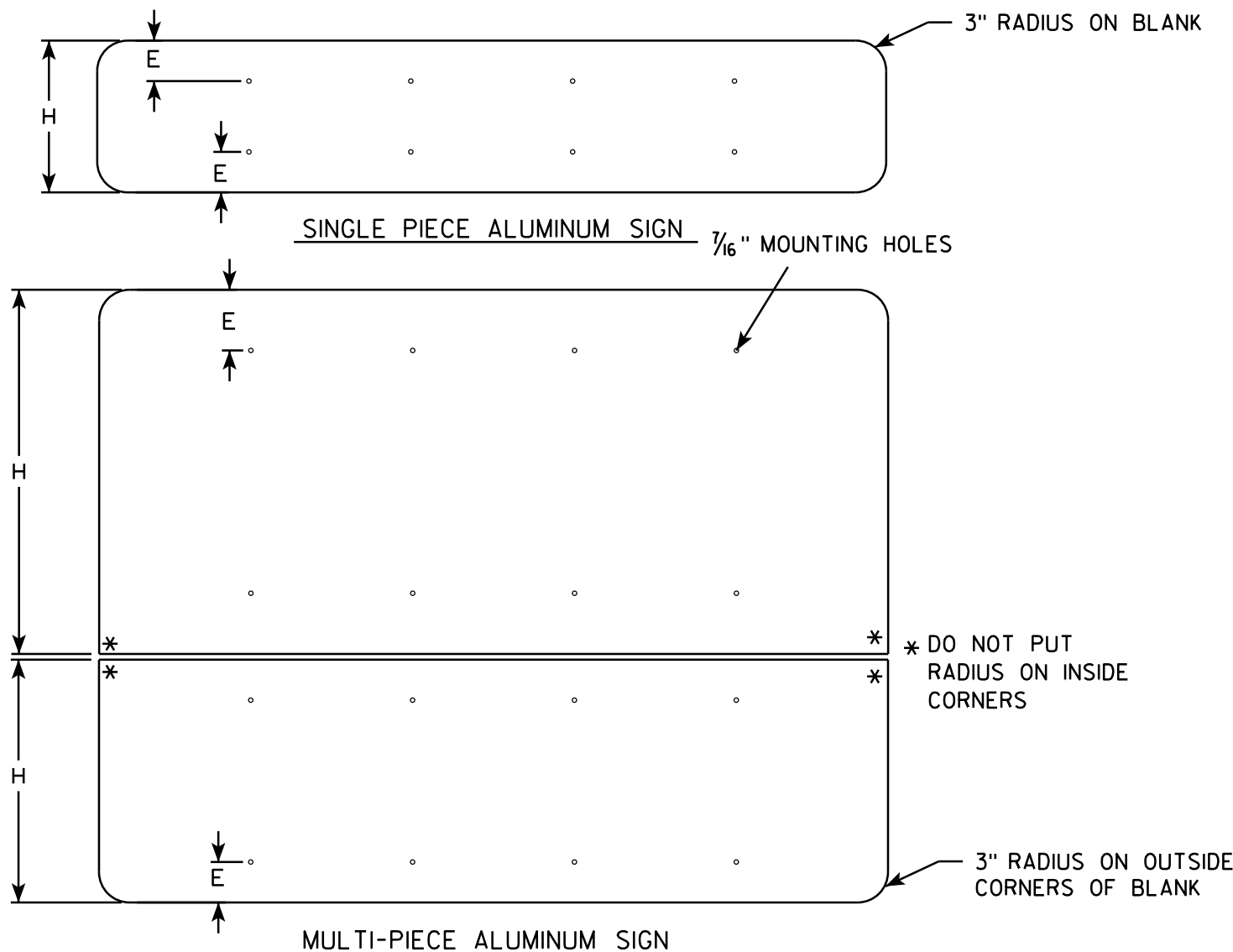

## GENERAL NOTES

- ALL SIGNS OVER 60" IN WIDTH SHALL HAVE A 3" RADIUS ON THE OUTSIDE CORNERS OF THE ALUMINUM BLANK.
- MOUNTING HOLES SHALL BE  $\frac{7}{16}$ " DIAMETER.
- SEE CHART FOR HOLE SPACING REQUIREMENTS
- FOR SIGN PANELS WITH DIMENSION (H) 36" AND OVER, DIMENSION E SHALL BE 6"
- FOR SIGN PANELS WITH DIMENSION (H) UNDER 36", DIMENSION E SHALL BE 4"
- SIGN STRINGER MATERIAL SHALL CONSIST OF STEEL CHANNEL POST SECTIONS, WEIGHING 1.12 LBS/FT IN ACCORDANCE WITH SECTION 633.2.1 OF THE STANDARD SPECIFICATIONS FOR HIGHWAY AND STRUCTURE CONSTRUCTION.
- SEE SIGN PLATE A4-8 FOR SIGN STRINGER BOLTING REQUIREMENTS.

SIGN WIDTH	STRINGER WIDTH	POSTS	HOLE SPACING	MOUNTING HOLES
78"	72"	2	16"	15" 31" 47" 63"
84"	72"	2	17"	16 $\frac{1}{2}$ " 33 $\frac{1}{2}$ " 50 $\frac{1}{2}$ " 67 $\frac{1}{2}$ "
90"	72"	2	18"	18" 36" 54" 72"
96"	90"	2	19"	19 $\frac{1}{2}$ " 38 $\frac{1}{2}$ " 57 $\frac{1}{2}$ " 76 $\frac{1}{2}$ "
102"	90"	2	20"	21" 41" 61" 81"
108"	90"	2	21"	22 $\frac{1}{2}$ " 43 $\frac{1}{2}$ " 64 $\frac{1}{2}$ " 85 $\frac{1}{2}$ "
114"	108"	3	15"	12" 27" 42" 57" 72" 87" 102"
120"	108"	3	16"	12" 28" 44" 60" 76" 92" 108"
126"	108"	3	17"	12" 29" 46" 63" 80" 97" 114"
132"	126"	3	18"	12" 30" 48" 66" 84" 102" 120"
138"	126"	3	19"	12" 31" 50" 69" 88" 107" 126"
144"	126"	3	20"	12" 32" 52" 72" 92" 112" 132"

7

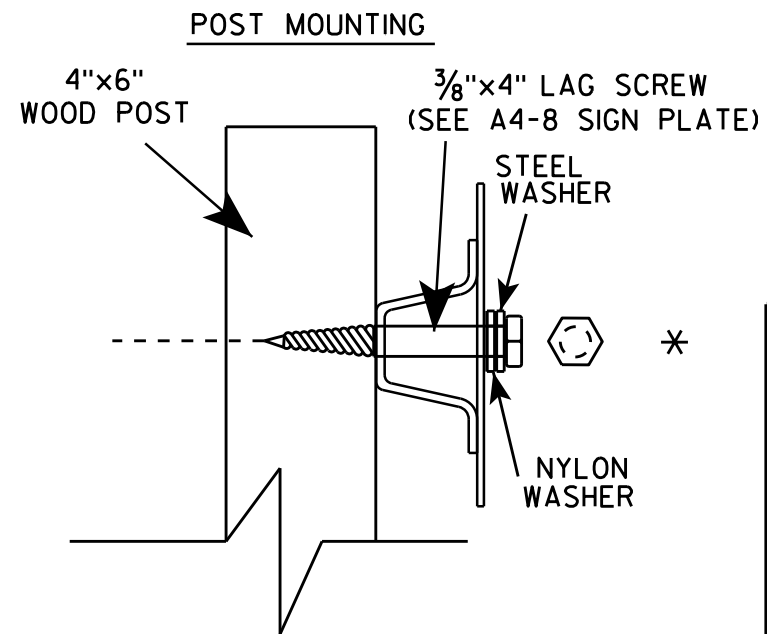
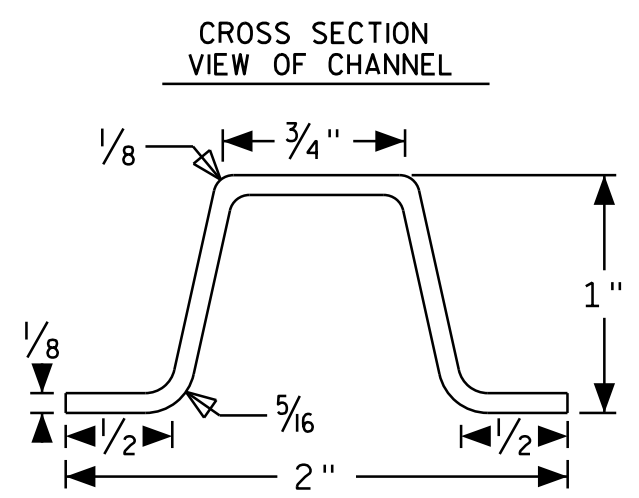
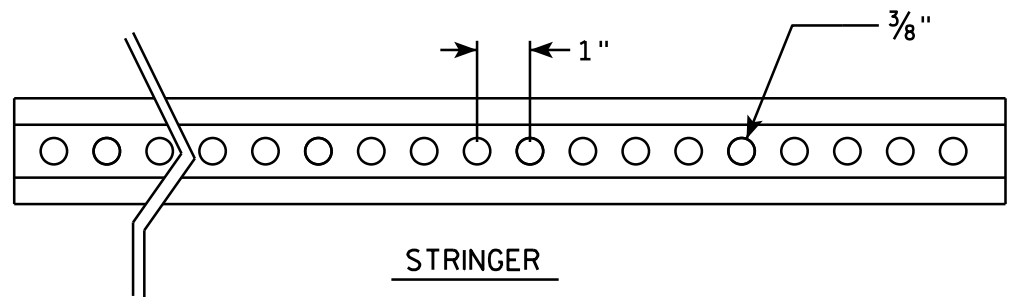

7

**SIGN STRINGER MOUNTING REQUIREMENTS**

WISCONSIN DEPT OF TRANSPORTATION

APPROVED *Matthew R. Rauch*  
for State Traffic Engineer

DATE 4/26/16 PLATE NO. A4-18.1



# BANDING

SINGLE SIGN

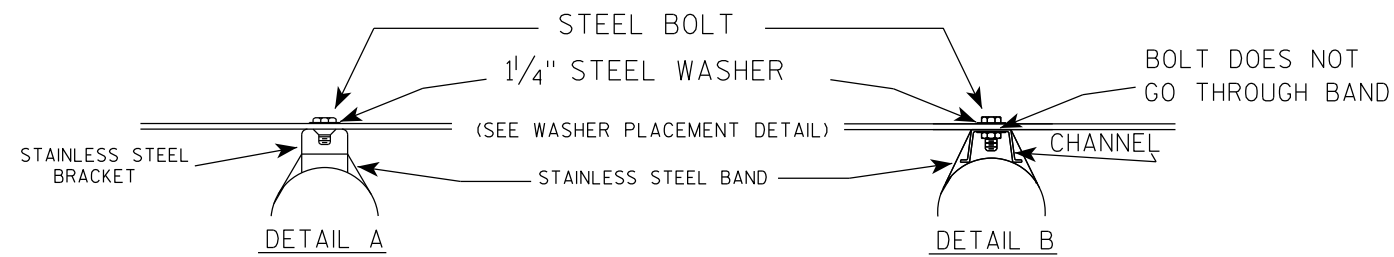
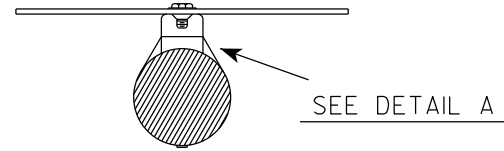
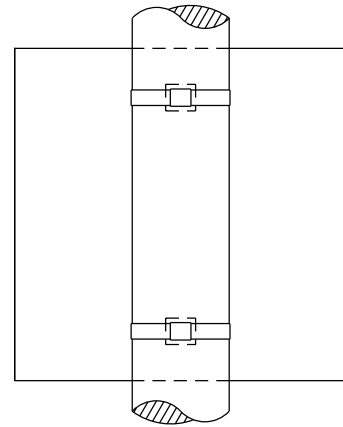

## GENERAL NOTES

1. Any sign over 3 feet in width shall use the V-Block banding method. See A5-10 standard plate.
2. Signs 3 feet or greater in height shall have three bracket bands installed. Signs less than 3 feet in height shall have two bracket bands installed.
3. Banding and assembly bracket shall be stainless steel. All bands shall be 3/4" in width and 0.025" thickness.
4. ALL SIGN MOUNTING BOLTS AND WASHERS SHALL BE EITHER:
  - a. Hot dip or mechanically galvanized in accordance with ASTM Designation: A 153, Class D
  - b. Electro-galvanized in accordance with ASTM designation: B 633, Type III, SC 3

"J" ASSEMBLY

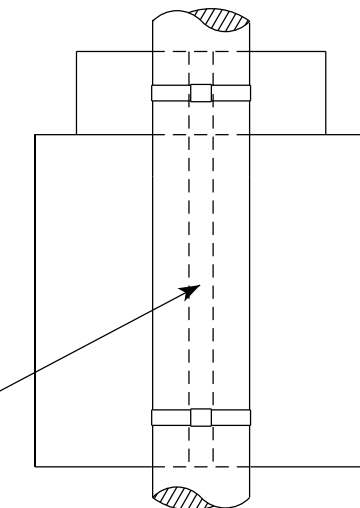

CHANNEL  
SEE TYPICAL PANEL  
INSTALLATION SHEET

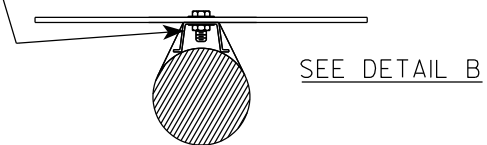

WASHER PLACEMENT

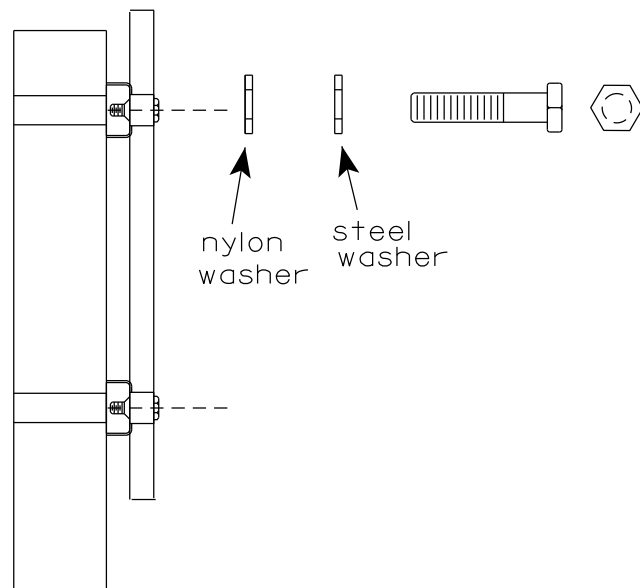

WASHERS (ALL POSTS) -  
1-1/4" O.D. X 3/8" I.D. X 1/16" STEEL  
1-1/4" O.D. X 3/8" I.D. X .080 NYLON  
FOR ALL TYPE H SIGNS

STANDARD SIGN  
SIGN BANDING DETAILS

WISCONSIN DEPT OF TRANSPORTATION

APPROVED *Matthew R. Rauch*  
for State Traffic Engineer

DATE 6/10/19 PLATE NO. A5-9.4

PROJECT NO:

HWY:

COUNTY:

SHEET NO:

E

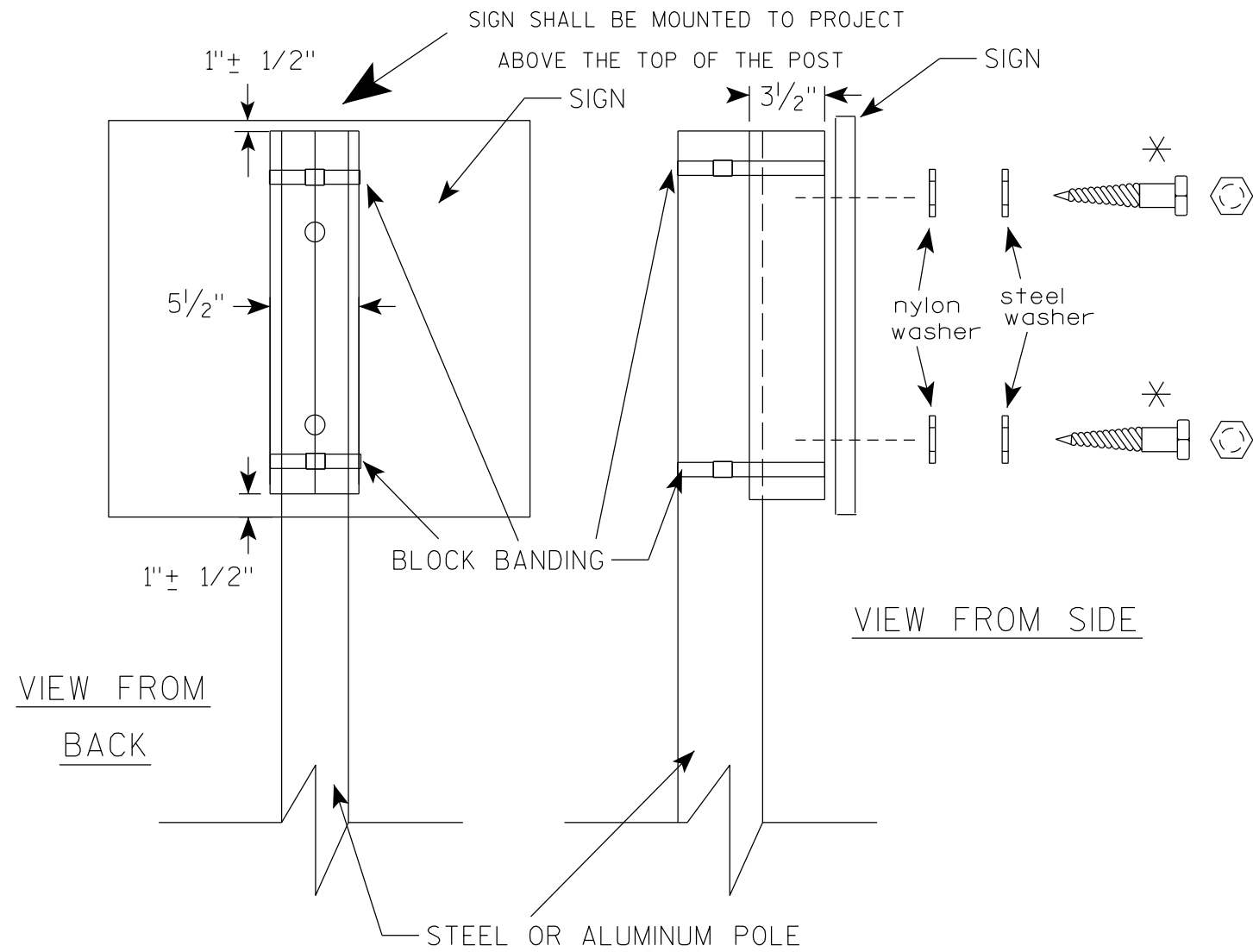

VIEW FROM  
BACK

VIEW FROM SIDE

STEEL OR ALUMINUM POLE

GENERAL NOTES

1. WOOD 4"X6" POST MATERIAL SHALL CONFORM TO 507.2.2 OF THE WISDOT STANDARD SPECIFICATIONS
2. BLOCK BANDING AND CLIPS SHALL BE STAINLESS STEEL, 3/4" WIDTH AND 0.025" THICKNESS
3. SIGNS 3' OR GREATER IN HEIGHT SHALL UTILIZE 3 BLOCK BANDS. SIGNS UNDER 3' IN HEIGHT SHALL UTILIZE 2 BLOCK BANDS
4. ACTUAL NUMBER OF FASTENERS PER SIGN VARIES WITH THE SIGN AREA, BUT NORMALLY THERE ARE TWO. FOR SIGNS GREATER THAN 9 S.F. 3 FASTENERS SHALL BE USED.
5. ALL SIGN MOUNTING BOLTS AND WASHERS SHALL BE EITHER:
  - a. Hot dip or mechanically galvanized in accordance with ASTM Designation: A 153, Class D
  - b. Electro-galvanized in accordance with ASTM Designation : B 633, TYPE III, SC 3
6. ALL BOLTS SHALL HAVE HEXAGONAL HEADS.
7. STEEL WASHERS SHALL BE 1/4" O.D. X 3/8" I.D. X 1/16"
8. NYLON WASHERS SHALL BE 1/4" O.D. X 3/8" I.D. X .080 FOR TYPE H OR TYPE F FACE SIGN

✱ LAG BOLTS SHALL BE 3/8" X 2 1/2"

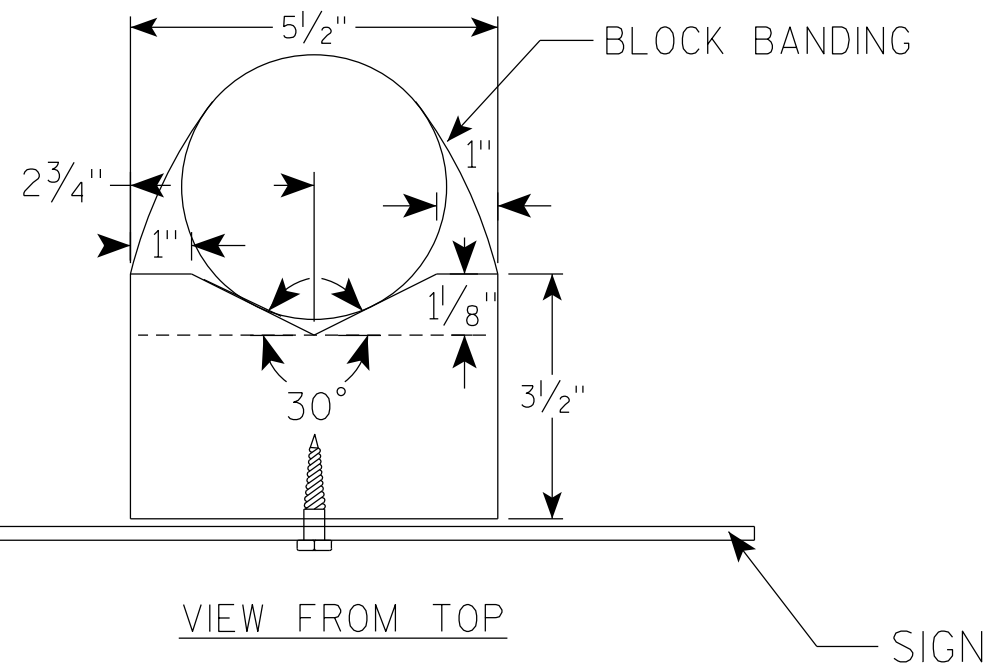

VIEW FROM TOP

SIGN

BLOCK BANDING DETAIL  
( V-BLOCK OPTION )

WISCONSIN DEPT OF TRANSPORTATION

APPROVED *Matthew R. Rauch*  
for State Traffic Engineer

DATE 4/19/2022 PLATE NO. A5-10.3

PROJECT NO:

SHEET NO:

**E**

**NOTES**

1. Sign is Type II - see Note 7 - reference WIS DOT Standard Specification for HIGHWAY and STRUCTURE CONSTRUCTION latest edition.
2. Color:  
Background - White & Black - See Note 7  
Message - Black
3. Message Series - see Note 5
4. Corners may be square or rounded when base material is plywood but borders shall be rounded as shown. When base material is metal, the corners and borders shall be rounded.
5. Message Series E for 1 letter.  
Message Series D for 2 letters unless message is too big then Series C.  
Message Series C for 3 letters unless message is too big then Series B.
6. Substitute appropriate letters & optically center to achieve proper balance.
7. Permanent Signs  
Background - Type H Reflective  
Detour or temporary Signs  
Background - Reflective

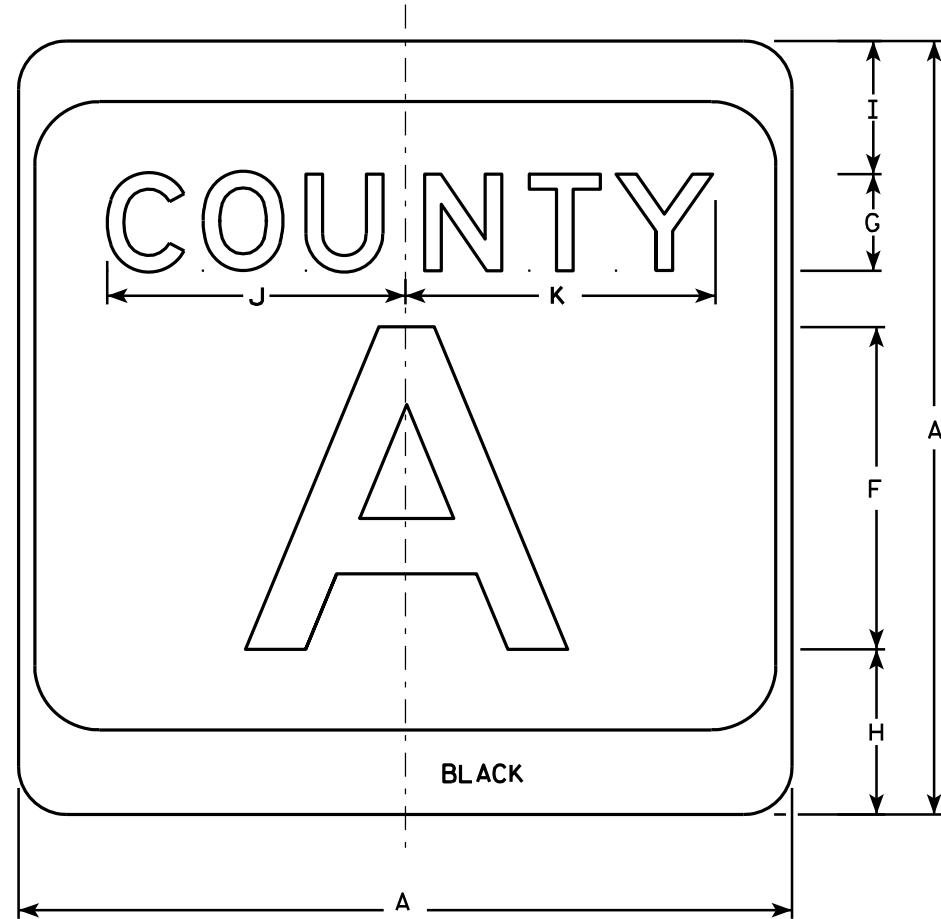

M1-5A

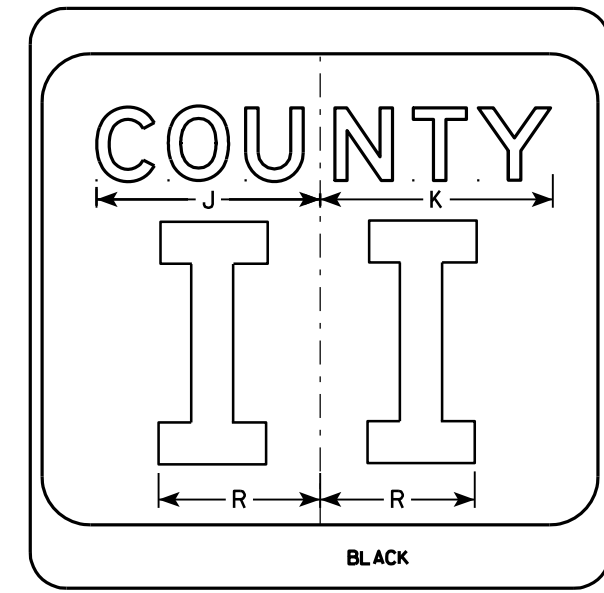
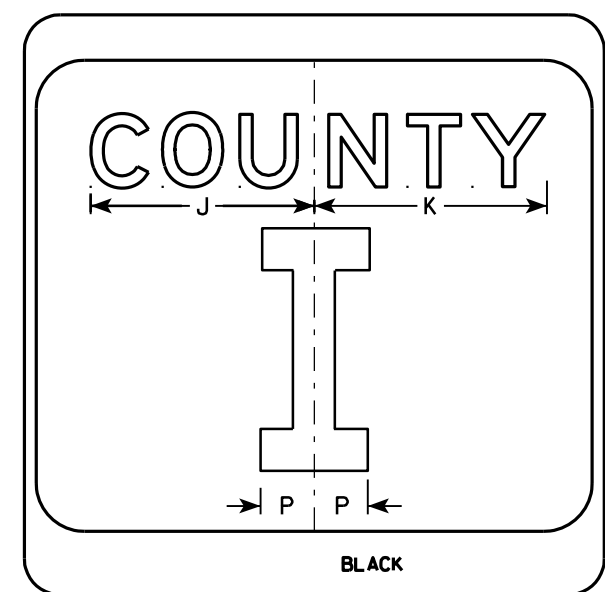
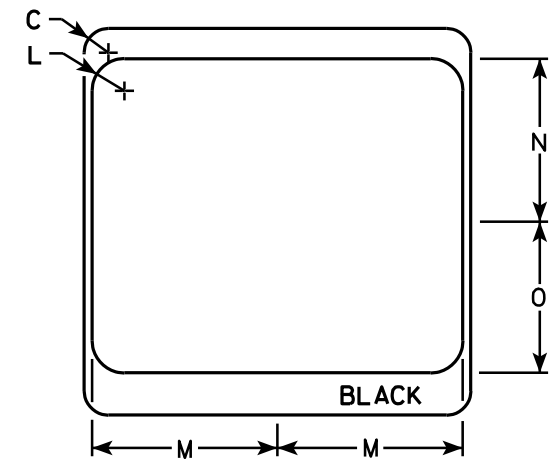

7

7

SIZE	A	B	C	D	E	F	G	H	I	J	K	L	M	N	O	P	Q	R	S	T	U	V	W	X	Y	Z	Area sq. ft.
1																											
2	24		1 1/2			10	3	5 1/8	4 1/8	9 1/4	9 5/8	2	11 1/2	10 1/8	9 3/8	2 1/4		6 5/8									4.0
3	36		2 1/4			16	4	7 5/8	5 5/8	12 1/4	12 7/8	3	17 1/8	15 1/4	14	3 3/8		10									9.0
4	36		2 1/4			16	4	7 5/8	5 5/8	12 1/4	12 7/8	3	17 1/8	15 1/4	14	3 3/8		10									9.0
5	36		2 1/4			16	4	7 5/8	5 5/8	12 1/4	12 7/8	3	17 1/8	15 1/4	14	3 3/8		10									9.0

**CTH MARKER**  
**M1-5A FOR ASSEMBLIES**

WISCONSIN DEPT OF TRANSPORTATION

APPROVED *Matthew R. Raub*  
For State Traffic Engineer

DATE 9/27/11 PLATE NO. MI-5A.8

PROJECT NO: \_\_\_\_\_ HWY: \_\_\_\_\_ COUNTY: \_\_\_\_\_ SHEET NO: **E**

NOTES

- All Signs Type II - Type H
- Color:
  - Background - See note 5
  - Message - See note 5
- Message Series - C
- Corners may be square or rounded when base material is plywood but borders shall be rounded as shown. When base material is metal, the corners and borders shall be rounded.
- M3-1 thru M3-4 Background - White  
 Message - Black  
 MB3-1 thru MB3-4 Background - Blue  
 Message - White  
 MK3-1 thru MK3-4 Background - Green  
 Message - White  
 MM3-1 thru MM3-4 Background - White  
 Message - Green  
 MN3-1 thru MN3-4 Background - Brown  
 Message - White  
 MP3-1 thru MP3-4 Background - White  
 Message - Blue
- Note the first letter of each direction is larger than the remainder of the message.

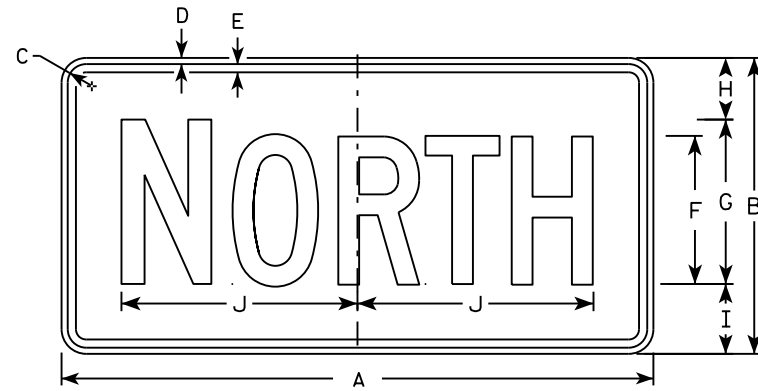

M3-1  
MM3-1  
MP3-1

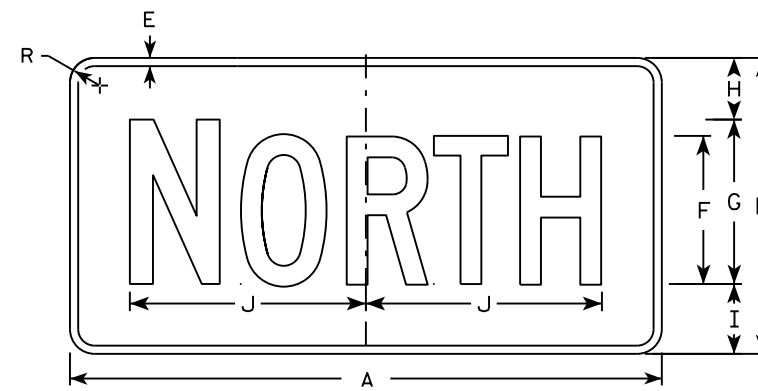

MB3-1  
MK3-1  
MN3-1

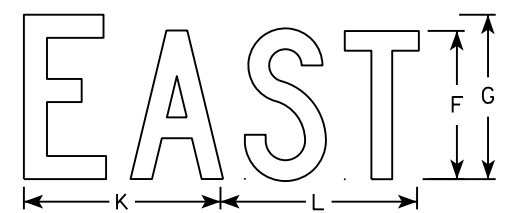

M3-2  
MM3-2  
MP3-2

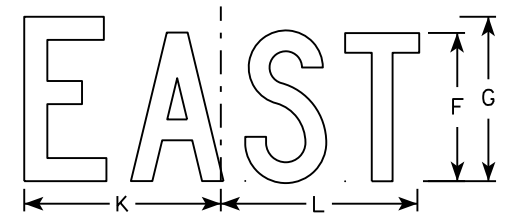

MB3-2  
MK3-2  
MN3-2

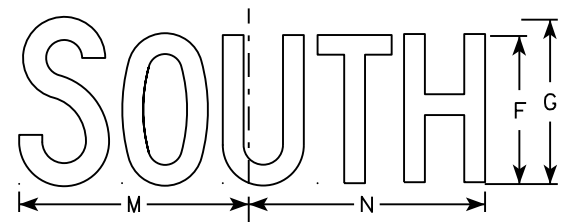

M3-3  
MM3-3  
MP3-3

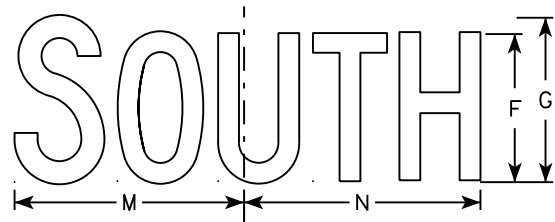

MB3-3  
MK3-3  
MN3-3

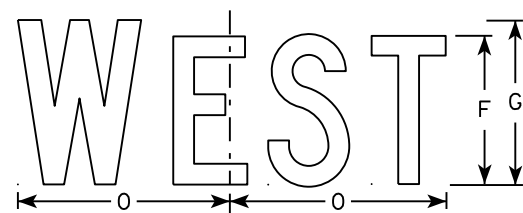

M3-4  
MM3-4  
MP3-4

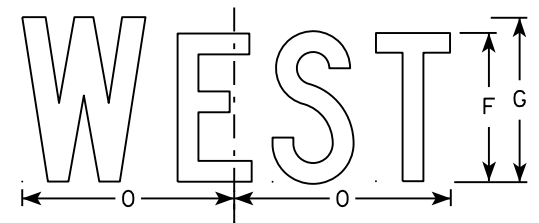

MB3-4  
MK3-4  
MN3-4

7

SIZE	A	B	C	D	E	F	G	H	I	J	K	L	M	N	O	P	Q	R	S	T	U	V	W	X	Y	Z	Area sq. ft.
1																											
2	24	12	1 1/8	3/8	3/8	6	7	2 1/4	2 3/4	10 1/4	7 7/8	8 3/8	10 1/4	9 3/4	8 3/4			1 1/2									2.00
3	36	18	1 1/8	3/8	1/2	9	10	3 3/4	4 1/4	14 3/8	12	12 1/8	14	14 1/8	13			1 1/2									4.5
4	36	18	1 1/8	3/8	1/2	9	10	3 3/4	4 1/4	14 3/8	12	12 1/8	14	14 1/8	13			1 1/2									4.5
5	36	18	1 1/8	3/8	1/2	9	10	3 3/4	4 1/4	14 3/8	12	12 1/8	14	14 1/8	13			1 1/2									4.5

STANDARD SIGNS  
M3-1 thru M3-4  
SERIES

WISCONSIN DEPT OF TRANSPORTATION

APPROVED *Matthew R. Rauch*  
for State Traffic Engineer

DATE 10/15/15 PLATE NO. M3-1.14

NOTES

1. Sign is Type II - Type F Reflective - reference WIS DOT Standard Specification for HIGHWAY and STRUCTURE CONSTRUCTION latest edition.
2. Color:  
Background - Orange  
Message - Black
3. Message Series - B
4. Corners may be square or rounded when base material is plywood but borders shall be rounded as shown. When base material is metal, the corners and borders shall be rounded.

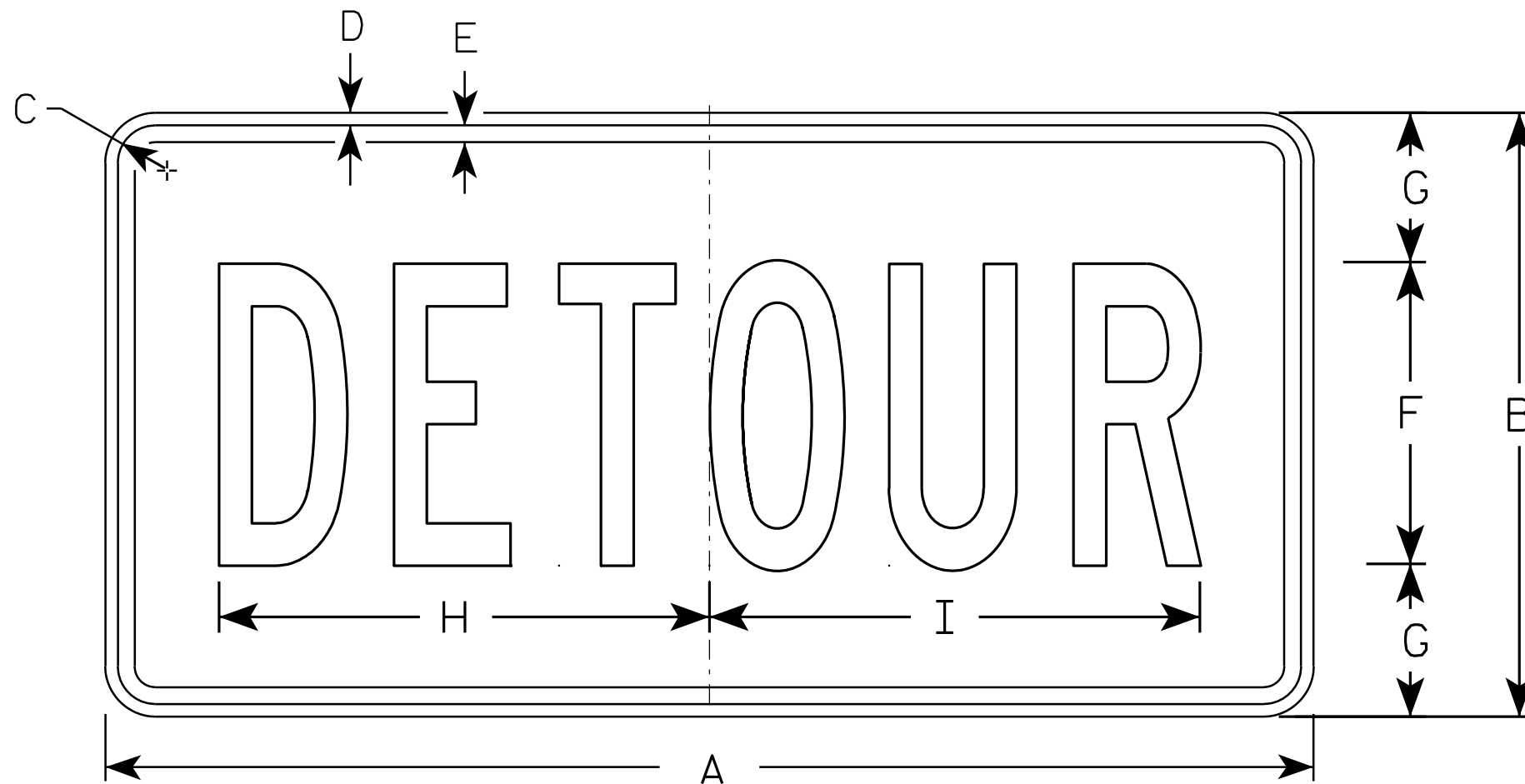

M4-8

7

7

SIZE	A	B	C	D	E	F	G	H	I	J	K	L	M	N	O	P	Q	R	S	T	U	V	W	X	Y	Z	Area sq. ft.
1																											
2	24	12	1 1/8	3/8	3/8	6	3	10	10 1/4																		2.0
3	36	18	1 1/8	3/8	1/2	9	4 1/2	14 5/8	14 1/2																		4.5
4																											
5																											

**STANDARD SIGN**  
**M4-8**

WISCONSIN DEPT OF TRANSPORTATION

APPROVED *Matthew R. Rauch*  
for State Traffic Engineer

DATE 11/10/10 PLATE NO. M4-8.2

PROJECT NO: \_\_\_\_\_ HWY: \_\_\_\_\_ COUNTY: \_\_\_\_\_ SHEET NO: **E**

NOTES

1. Sign is Type II - Type F Reflective - reference WIS DOT Standard Specification for HIGHWAY and STRUCTURE CONSTRUCTION latest edition.
2. Color:  
Background - Orange  
Message - Black
3. Message Series - B
4. Corners may be square or rounded when base material is plywood but borders shall be rounded as shown. When base material is metal, the corners and borders shall be rounded.

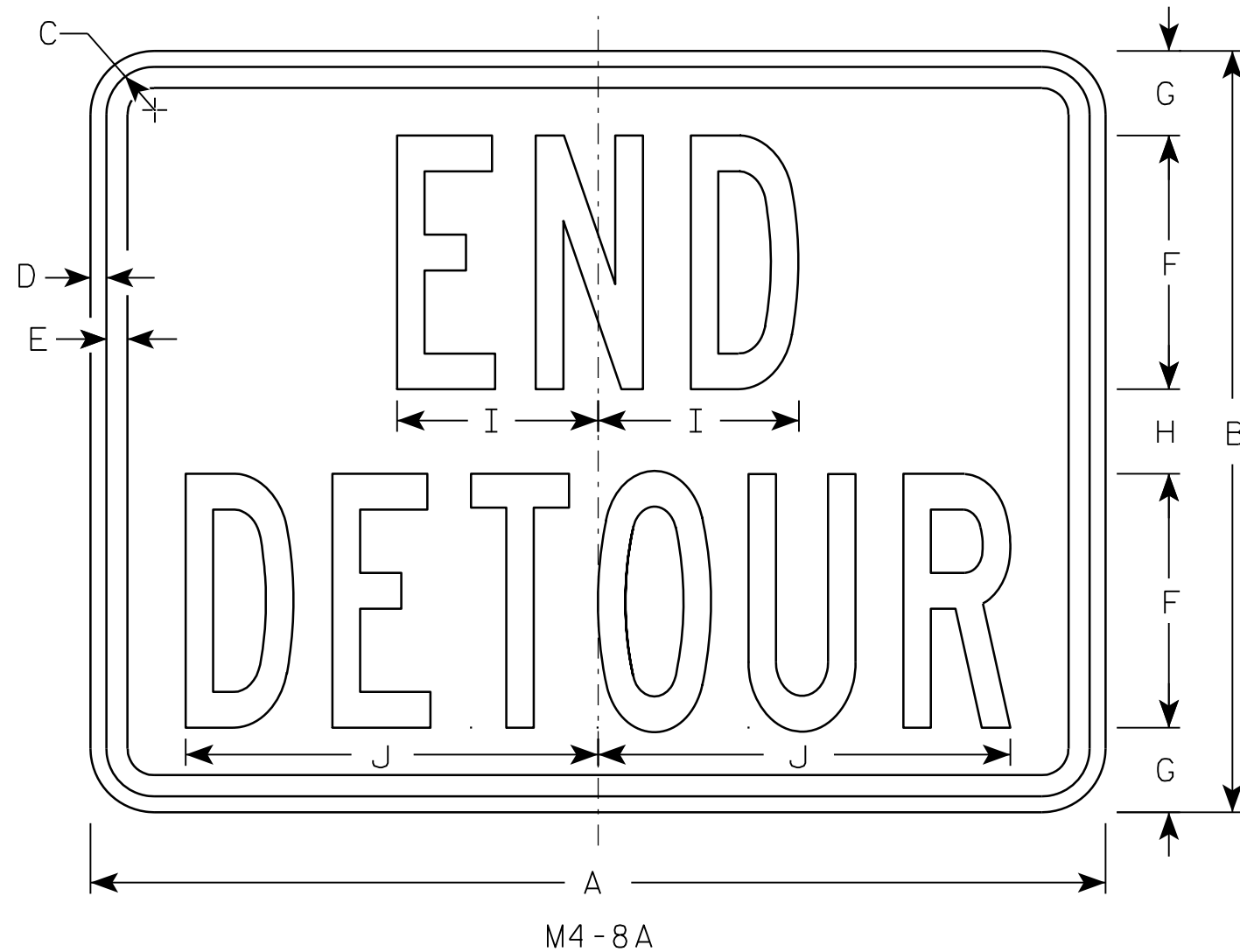

7

7

SIZE	A	B	C	D	E	F	G	H	I	J	K	L	M	N	O	P	Q	R	S	T	U	V	W	X	Y	Z	Area sq. ft.
1																											
2	24	18	1 1/8	3/8	1/2	6	2	2	4 3/4	9 3/4																	3.0
3	30	24	1 1/8	3/8	1/2	8	2 1/2	3	6 3/4	13																	5.0
4																											
5																											

STANDARD SIGN  
M4-8A

WISCONSIN DEPT OF TRANSPORTATION

APPROVED *Matthew R. Rauch*  
for State Traffic Engineer

DATE 3/9/11 PLATE NO. M4-8A.2

PROJECT NO: \_\_\_\_\_ HWY: \_\_\_\_\_ COUNTY: \_\_\_\_\_ SHEET NO: **E**

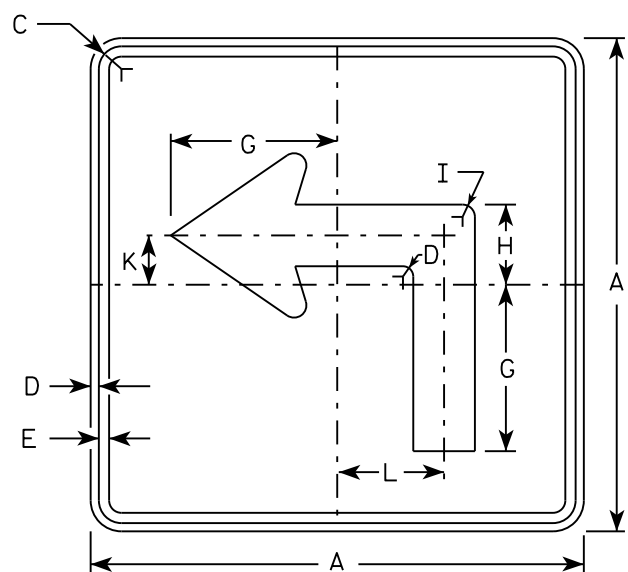

M5-1L  
MM5-1L  
M05-1L  
MP5-1L

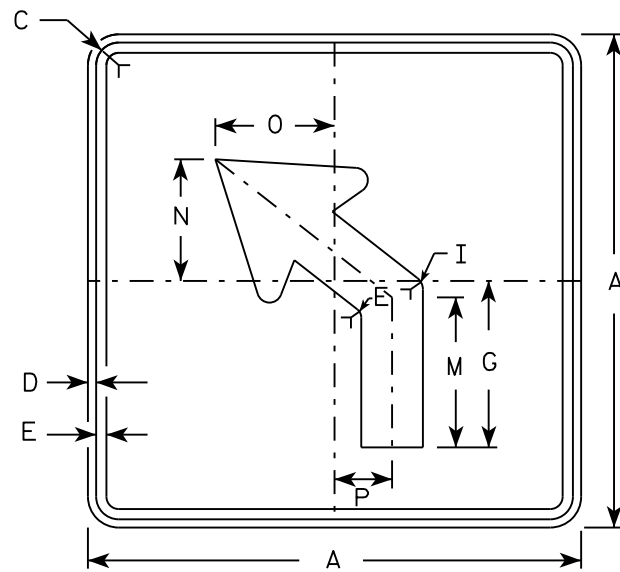

M5-2L  
MM5-2L  
M05-2L  
MP5-2L

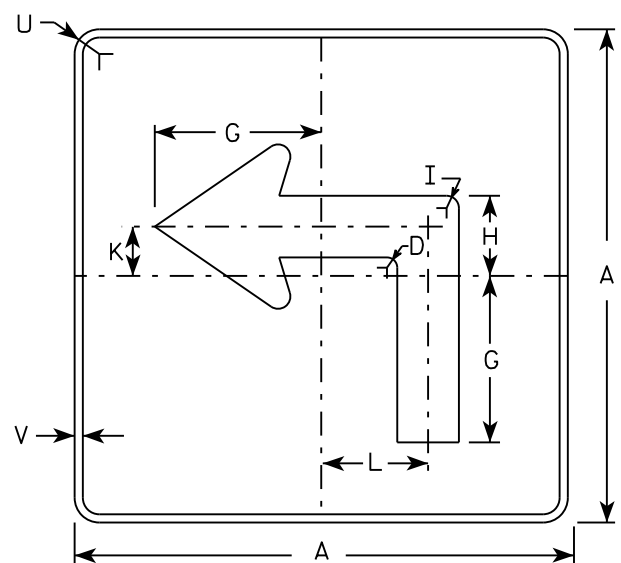

MB5-1L  
MK5-1L  
MN5-1L  
MR5-1L

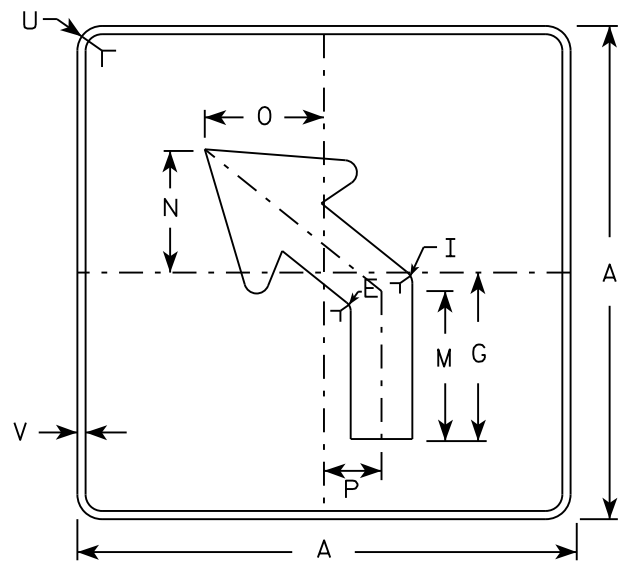

MB5-2L  
MK5-2L  
MN5-2L  
MR5-2L

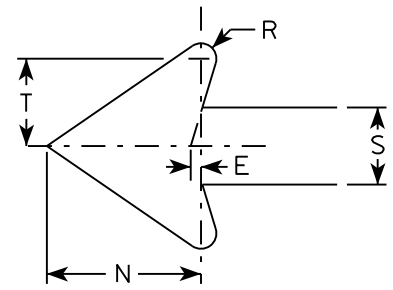

NOTES

- Signs are Type II - Type H reflective except as shown
- Color:
  - Background - See note 4
  - Message - See note 4
- Corners may be square or rounded when base material is plywood but borders shall be rounded as shown. When base material is metal, the corners and borders shall be rounded.
- M5-1 and M5-2 Background - White  
Message - Black
  - MB5-1 and MB5-2 Background - Blue  
Message - White
  - MK5-1 and MK5-2 Background - Green  
Message - White
  - MM5-1 and MM5-2 Background - White  
Message - Green
  - MN5-1 and MN5-2 Background - Brown  
Message - White
  - M05-1 and M05-2 Background - Orange - Type F Reflective  
Message - Black
  - MP5-1 and MP5-2 Background - White - Type H Reflective  
Message - Blue
  - MR5-1 and MR5-2 Background - Brown  
Message - Yellow
- M5-1R same as M5-1L except arrow points right.
- M5-2R same as M5-2L except arrow tilts right.

SIZE	A	B	C	D	E	F	G	H	I	J	K	L	M	N	O	P	Q	R	S	T	U	V	W	X	Y	Z	Area sq. ft.
1																											
2	21		1 1/8	3/8	3/8		7	3 3/8	5/8		2 1/8	4 1/2	6 3/8	5 1/4	5	2 1/2		1/2	2 5/8	3	1 1/2	1/2					3.06
3	30		1 3/8	1/2	5/8		10 1/8	4 7/8	7/8		3	6 1/2	9 1/8	7 1/2	7 1/4	3 1/2		3/4	3 3/4	4 1/4	1 7/8	1/2					6.25
4	30		1 3/8	1/2	5/8		10 1/8	4 7/8	7/8		3	6 1/2	9 1/8	7 1/2	7 1/4	3 1/2		3/4	3 3/4	4 1/4	1 7/8	1/2					6.25
5	30		1 3/8	1/2	5/8		10 1/8	4 7/8	7/8		3	6 1/2	9 1/8	7 1/2	7 1/4	3 1/2		3/4	3 3/4	4 1/4	1 7/8	1/2					6.25

STANDARD SIGN  
M5-1 & M5-2

WISCONSIN DEPT OF TRANSPORTATION

APPROVED *Matthew R. Rauch*  
for State Traffic Engineer

DATE 10/15/15 PLATE NO. M5-1.13

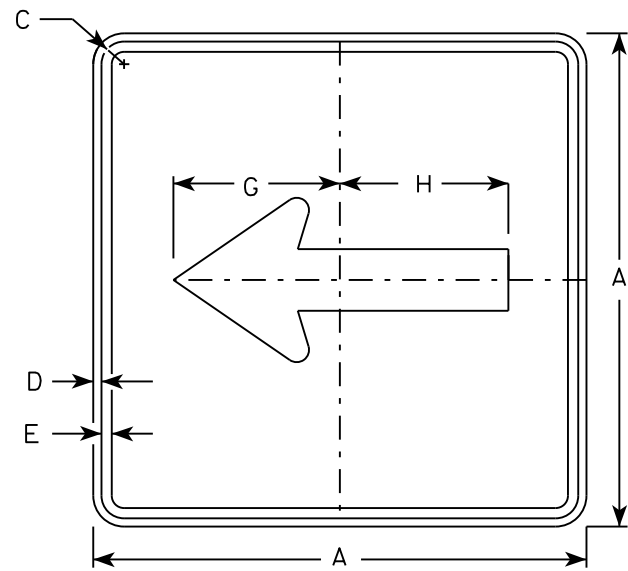

M6-1  
MM6-1  
M06-1  
MP6-1

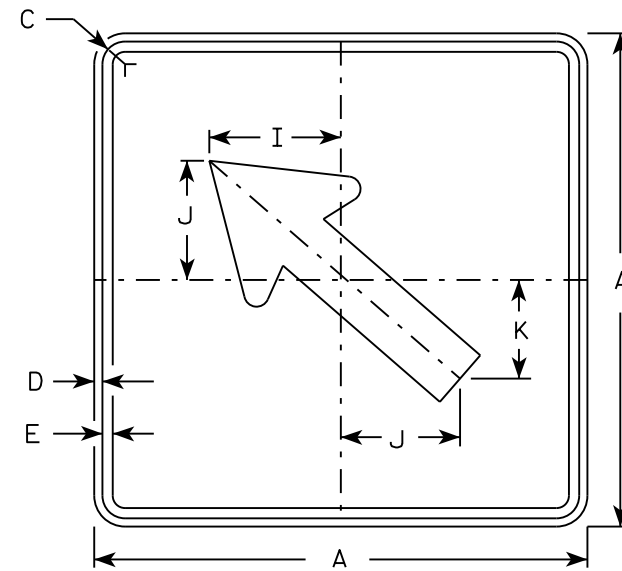

M6-2  
MM6-2  
M06-2  
MP6-2

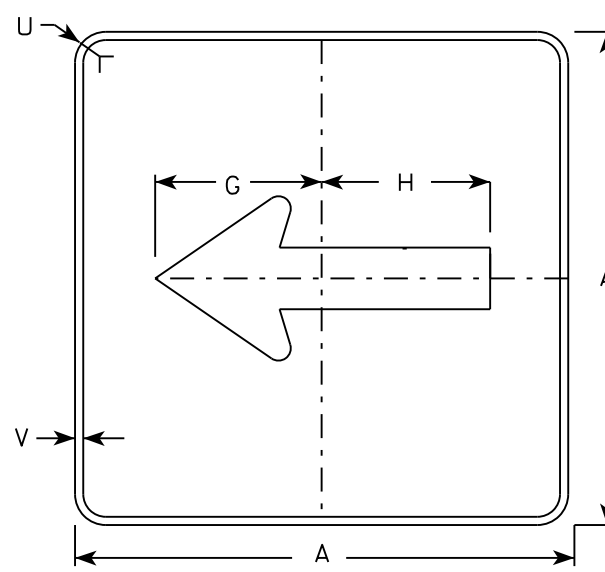

MB6-1  
MK6-1  
MN6-1  
MR6-1

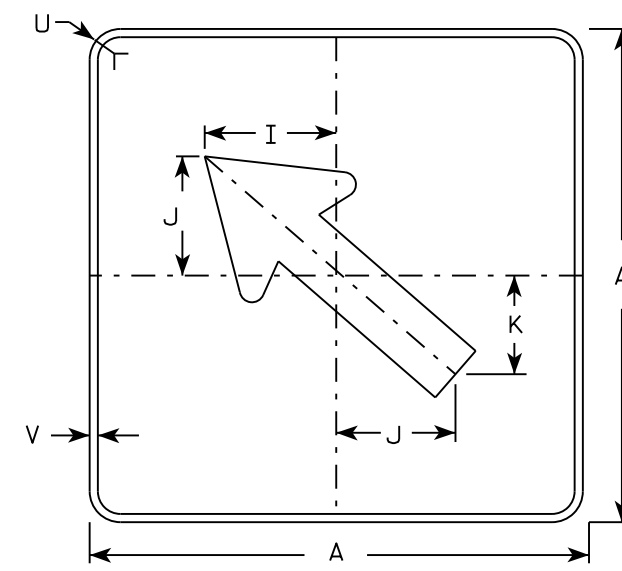

MB6-2  
MK6-2  
MN6-2  
MR6-2

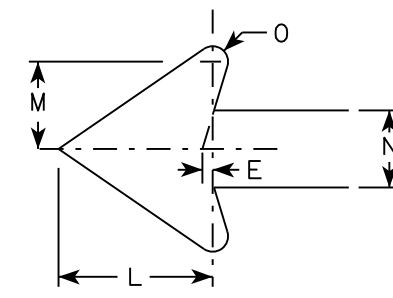

NOTES

- Signs are Type II - Type H except as Shown
- Color:  
Background - See note 4  
Message - See note 4
- Corners may be square or rounded when base material is plywood but borders shall be rounded as shown. When base material is metal, the corners and borders shall be rounded.
- M6-1 and M6-2 Background - White  
Message - Black  
MB6-1 and MB6-2 Background - Blue  
Message - White  
MK6-1 and MK6-2 Background - Green  
Message - White  
MM6-1 and MM6-2 Background - White  
Message - Green  
MN6-1 and MN6-2 Background - Brown  
Message - White  
M06-1 and M06-2 Background - Orange - Type F Reflective  
Message - Black  
MP6-1 and MP6-2 Background - White  
Message - Blue  
MR6-1 and MR6-2 Background - Brown  
Message - Yellow

7

SIZE	A	B	C	D	E	F	G	H	I	J	K	L	M	N	O	P	Q	R	S	T	U	V	W	X	Y	Z	Area sq. ft.
1																											
2	21		1 1/8	3/8	3/8		7 1/2	7 1/8	5 5/8	5	4 1/4	5 1/4	3	2 5/8	1/2						1 1/2	1/2					3.06
3	30		1 3/8	1/2	5/8		10 3/4	10 1/4	8	7 1/4	6	7 1/2	4 1/4	3 3/4	3/4						1 7/8	1/2					6.25
4	30		1 3/8	1/2	5/8		10 3/4	10 1/4	8	7 1/4	6	7 1/2	4 1/4	3 3/4	3/4						1 7/8	1/2					6.25
5	30		1 3/8	1/2	5/8		10 3/4	10 1/4	8	7 1/4	6	7 1/2	4 1/4	3 3/4	3/4						1 7/8	1/2					6.25

STANDARD SIGN  
M6-1 & M6-2  
SERIES

WISCONSIN DEPT OF TRANSPORTATION

APPROVED *Matthew R. Rauch*  
for State Traffic Engineer

DATE 10/15/15 PLATE NO. M6-1.15



NOTES

1. Sign is Type II - Type H Reflective - reference WIS DOT Standard Specification for HIGHWAY and STRUCTURE CONSTRUCTION latest edition.
2. Color:  
Background - White  
Message - See note 5
3. Message Series - C
4. Corners may be square or rounded when base material is plywood but borders shall be rounded as shown. When base material is metal, the corners and borders shall be rounded.
5. The border strip and word message are reflectorized red.

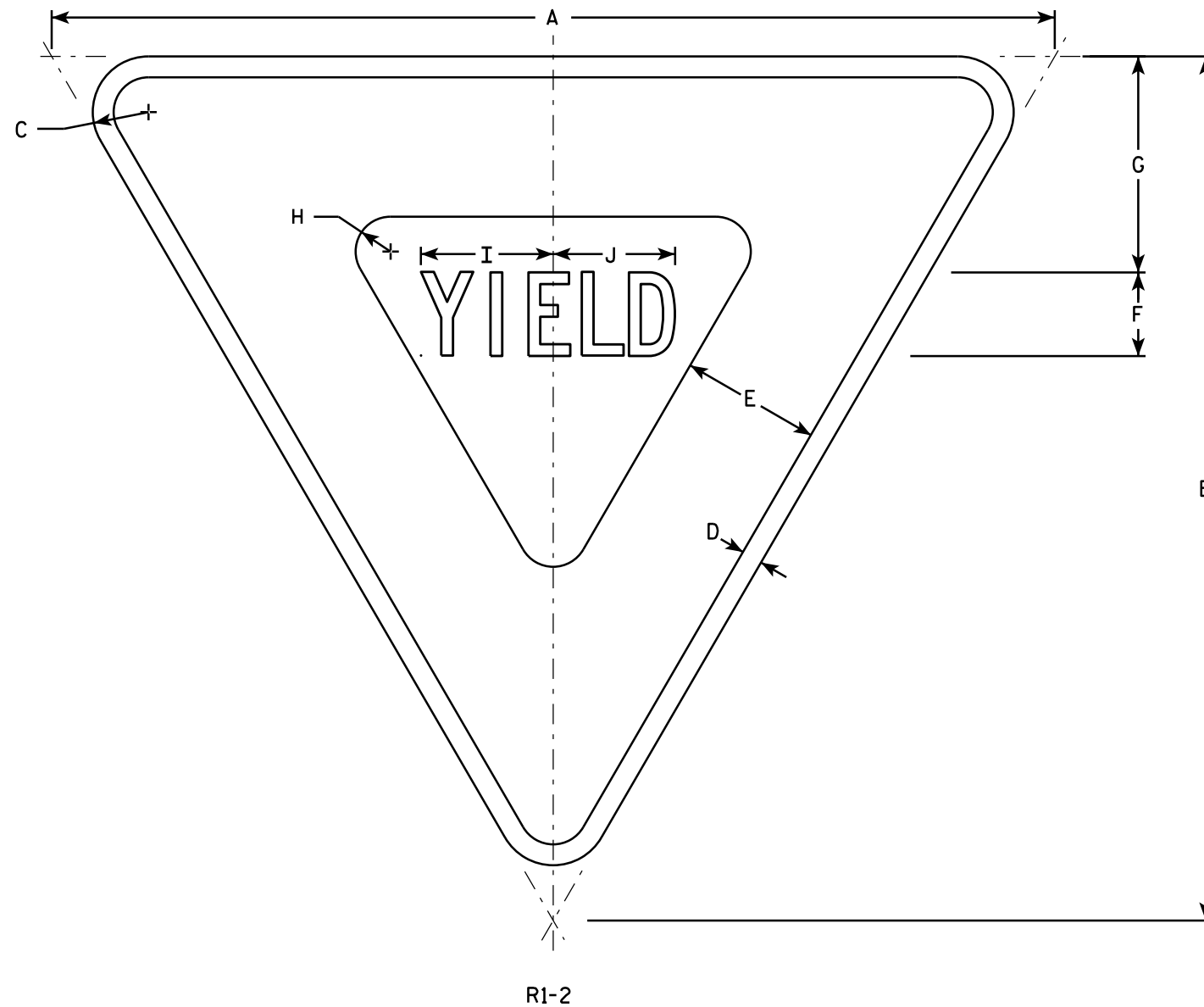

7

7

SIZE	A	B	C	D	E	F	G	H	I	J	K	L	M	N	O	P	Q	R	S	T	U	V	W	X	Y	Z	Area sq. ft.
1	30	26	1 1/2	5/8	4	2 1/2	6 3/8	7/8	4	3 5/8																	2.71
2S	36	31	2	3/4	5	3	7 3/4	1 1/4	4 3/4	4 3/8																	3.88
2M	48	42	3	1	6	4	9 3/4	2	6 1/4	5 7/8																	7.00
3	48	42	3	1	6	4	9 3/4	2	6 1/4	5 7/8																	7.00
4	48	42	3	1	6	4	9 3/4	2	6 1/4	5 7/8																	7.00
5	60	52	3	1 1/2	8	5	13	2 1/2	7 7/8	7 1/4																	10.83
6																											
7	18	15 1/2	1	3/8	2 1/2	1 1/2	3 7/8	5/8	2 3/8	2 1/4																	0.97

**STANDARD SIGN**  
R1-2

WISCONSIN DEPT OF TRANSPORTATION

APPROVED *Matthew R. Rauch*  
for State Traffic Engineer

DATE 10/13/14 PLATE NO. R1-2.12

NOTES

1. Sign is Type II - Type H Reflective - reference WIS DOT Standard Specification for HIGHWAY and STRUCTURE CONSTRUCTION latest edition.
2. Color:  
Background - White  
Message - Black
3. Message Series - B



R1-54

7

7

SIZE	A	B	C	D	E	F	G	H	I	J	K	L	M	N	O	P	Q	R	S	T	U	V	W	X	Y	Z	Area sq. ft.
1																											
2S	24	15	1 1/8	3/8	3/8	4	2 5/8	1 3/4	3 3/4	2	4 1/8	9 3/4	8 7/8	5/8	1 7/8	7 3/4											2.5
2M	24	15	1 1/8	3/8	3/8	4	2 5/8	1 3/4	3 3/4	2	4 1/8	9 3/4	8 7/8	5/8	1 7/8	7 3/4											2.5
3																											
4																											
5																											

STANDARD SIGN  
R1-54

WISCONSIN DEPT OF TRANSPORTATION

APPROVED *Matthew R. Rauch*  
For State Traffic Engineer

DATE 12/03/10 PLATE NO. R1-54.2

PROJECT NO:

HWY:

COUNTY:

SHEET NO:

E

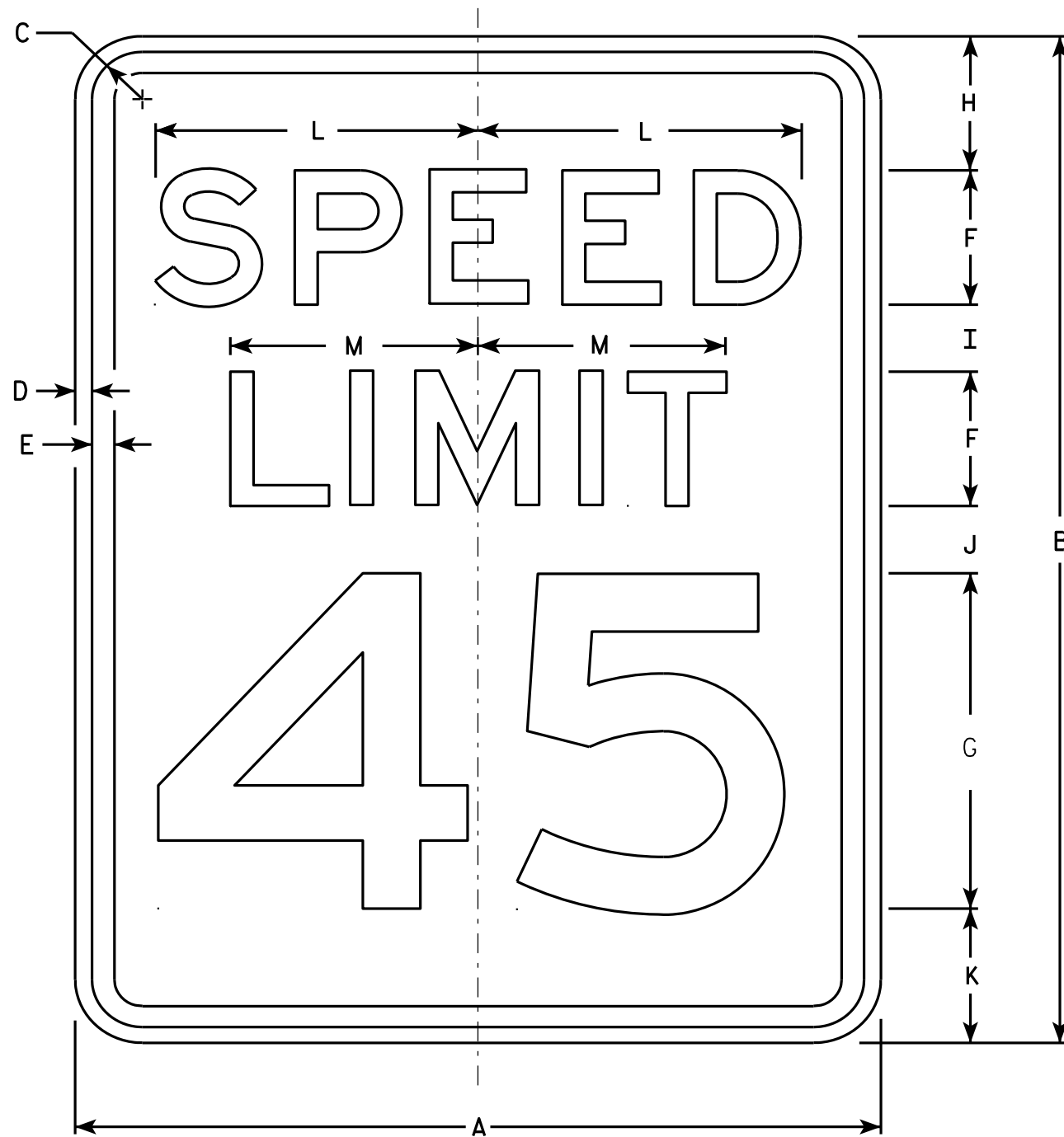

R2-1

NOTES

1. Sign is Type II - Type H Reflective - reference WIS DOT Standard Specification for HIGHWAY and STRUCTURE CONSTRUCTION latest edition.
2. Color:  
Background - White  
Message - Black
3. Message Series - E
4. Corners may be square or rounded when base material is plywood but borders shall be rounded as shown. When base material is metal, the corners and borders shall be rounded.
5. Substitute appropriate numerals and optically adjust spacing to achieve proper balance.

7

7

SIZE	A	B	C	D	E	F	G	H	I	J	K	L	M	N	O	P	Q	R	S	T	U	V	W	X	Y	Z	Area sq. ft.
1	18	24	1 1/8	3/8	1/2	3	8	3	2	2	3	7 1/4	5 1/2														3.0
2S	24	30	1 1/8	3/8	1/2	4	10	3	2 1/4	3 3/8	3 3/8	9 5/8	7 3/8														5.0
2M	30	36	1 3/8	1/2	5/8	5	12	5	2 1/2	2 1/2	4	12	9 1/4														7.5
3	36	48	1 3/8	1/2	5/8	6	14	6	5	5	6	14 3/8	11														12.0
4	36	48	1 3/8	1/2	5/8	6	14	6	5	5	6	14 3/8	11														12.0
5	48	60	2 1/4	3/4	1	8	20	6	4 1/2	6 3/4	6 3/4	19 1/4	14 5/8														20.0

STANDARD SIGN  
R2-1

WISCONSIN DEPT OF TRANSPORTATION

APPROVED *Matthew R. Rauch*  
For State Traffic Engineer

DATE 5/26/10 PLATE NO. R2-1.13

PROJECT NO: \_\_\_\_\_ HWY: \_\_\_\_\_ COUNTY: \_\_\_\_\_ SHEET NO: \_\_\_\_\_ E

**NOTES**

1. Sign is Type II - Type H Reflective - reference WIS DOT Standard Specification for HIGHWAY and STRUCTURE CONSTRUCTION latest edition. material is plywood but borders shall be rounded
2. Color:  
Background - White  
Message - Black
3. Corners may be square or rounded when base as shown. When base material is metal, the corners and borders shall be rounded.
4. R4-8 is the same as R4-7 except Legend is reversed.

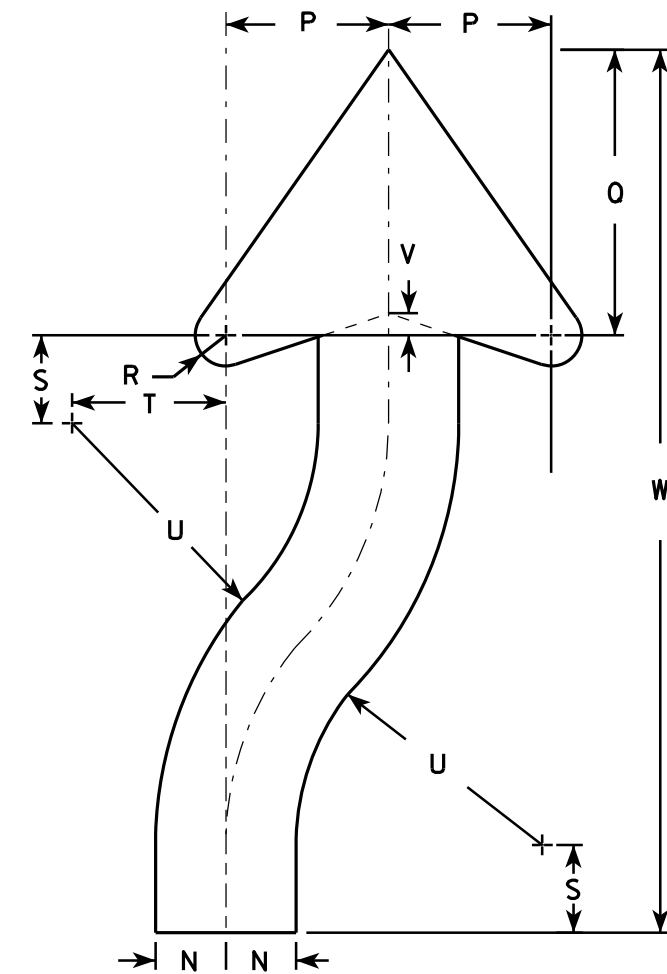
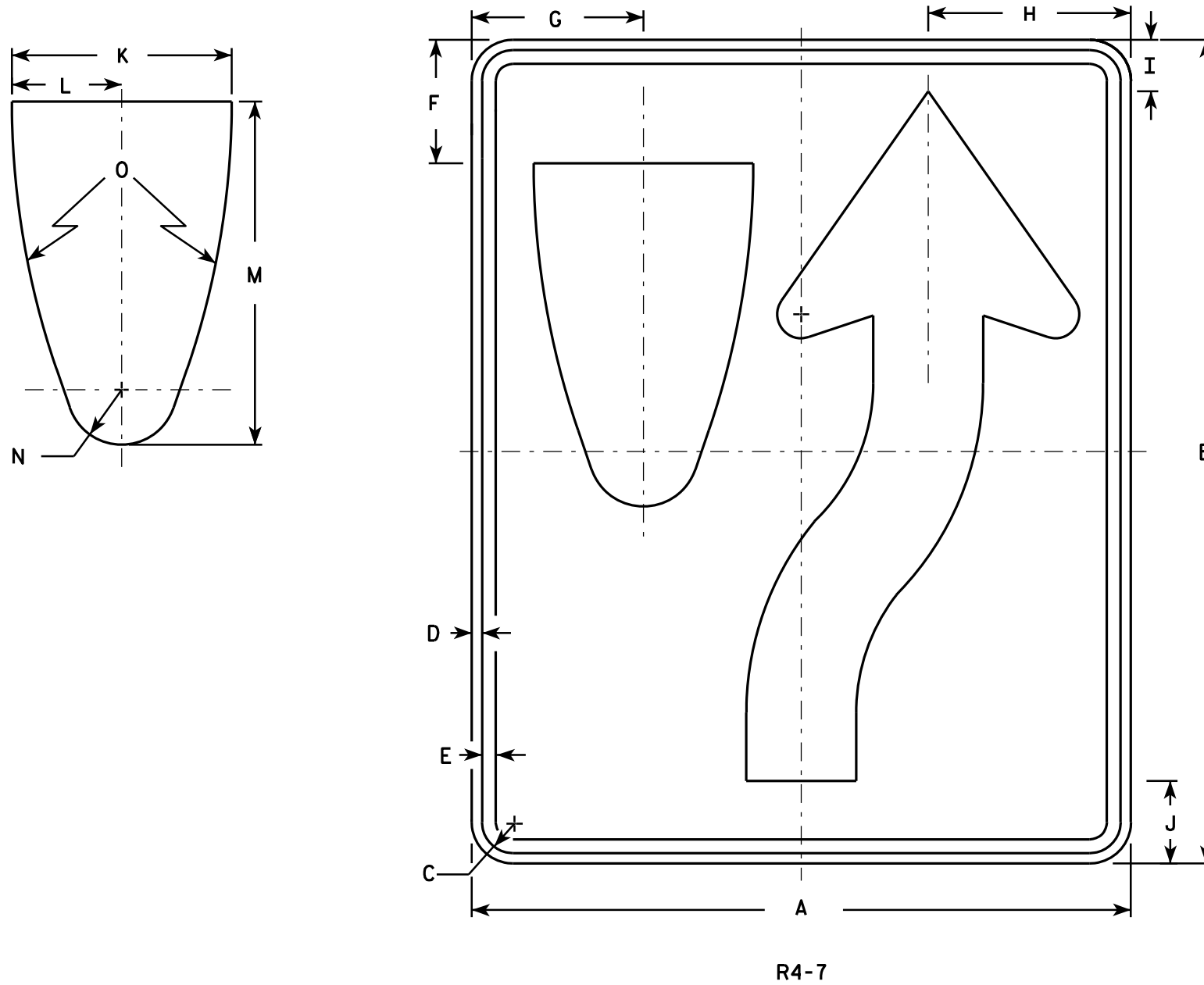

SIZE	A	B	C	D	E	F	G	H	I	J	K	L	M	N	O	P	Q	R	S	T	U	V	W	X	Y	Z	Area sq. ft.
1	18	24	1 1/8	3/8	1/2	3 3/8	4 3/4	5 1/2	1 3/8	2 1/4	6	3	9 3/8	1 1/2	22 1/2	3 1/2	6 1/8	5/8	1 7/8	3 1/4	6 3/4	1/2	20 3/8				3.0
2S	24	30	1 1/8	3/8	1/2	4 1/2	6 1/4	7 3/8	1 7/8	3	8	4	12 1/2	2	30	4 5/8	8 1/8	7/8	2 1/2	4 3/8	9	5/8	25 1/8				5.0
2M	24	30	1 1/8	3/8	1/2	4 1/2	6 1/4	7 3/8	1 7/8	3	8	4	12 1/2	2	30	4 5/8	8 1/8	7/8	2 1/2	4 3/8	9	5/8	25 1/8				5.0
3	36	48	1 3/4	1/2	5/8	6 3/4	9 3/8	11 1/8	2 7/8	4 1/2	12	6	18 3/4	3	45	6 7/8	12 1/4	1 1/4	3 3/4	6 5/8	13 1/2	1	40 3/4				12.0
4	36	48	1 3/4	1/2	5/8	6 3/4	9 3/8	11 1/8	2 7/8	4 1/2	12	6	18 3/4	3	45	6 7/8	12 1/4	1 1/4	3 3/4	6 5/8	13 1/2	1	40 3/4				12.0
5	48	60	2 1/4	3/4	1	9	12 1/2	14 3/4	3 3/4	6	16	8	25	4	60	9 1/4	16 1/4	1 5/8	5	8 3/4	18	1 1/4	50 1/4				20.0

**STANDARD SIGN**  
R4-7 & R4-8

WISCONSIN DEPT OF TRANSPORTATION

APPROVED *Matthew R. Rauch*  
for State Traffic Engineer

DATE 3/25/2011 PLATE NO. R4-7.8

PROJECT NO: \_\_\_\_\_ HWY: \_\_\_\_\_ COUNTY: \_\_\_\_\_ SHEET NO: \_\_\_\_\_ **E**

NOTES

1. Sign is Type II - Type H Reflective
2. Color:  
Background - See detail  
Message - White
3. Message Series - D

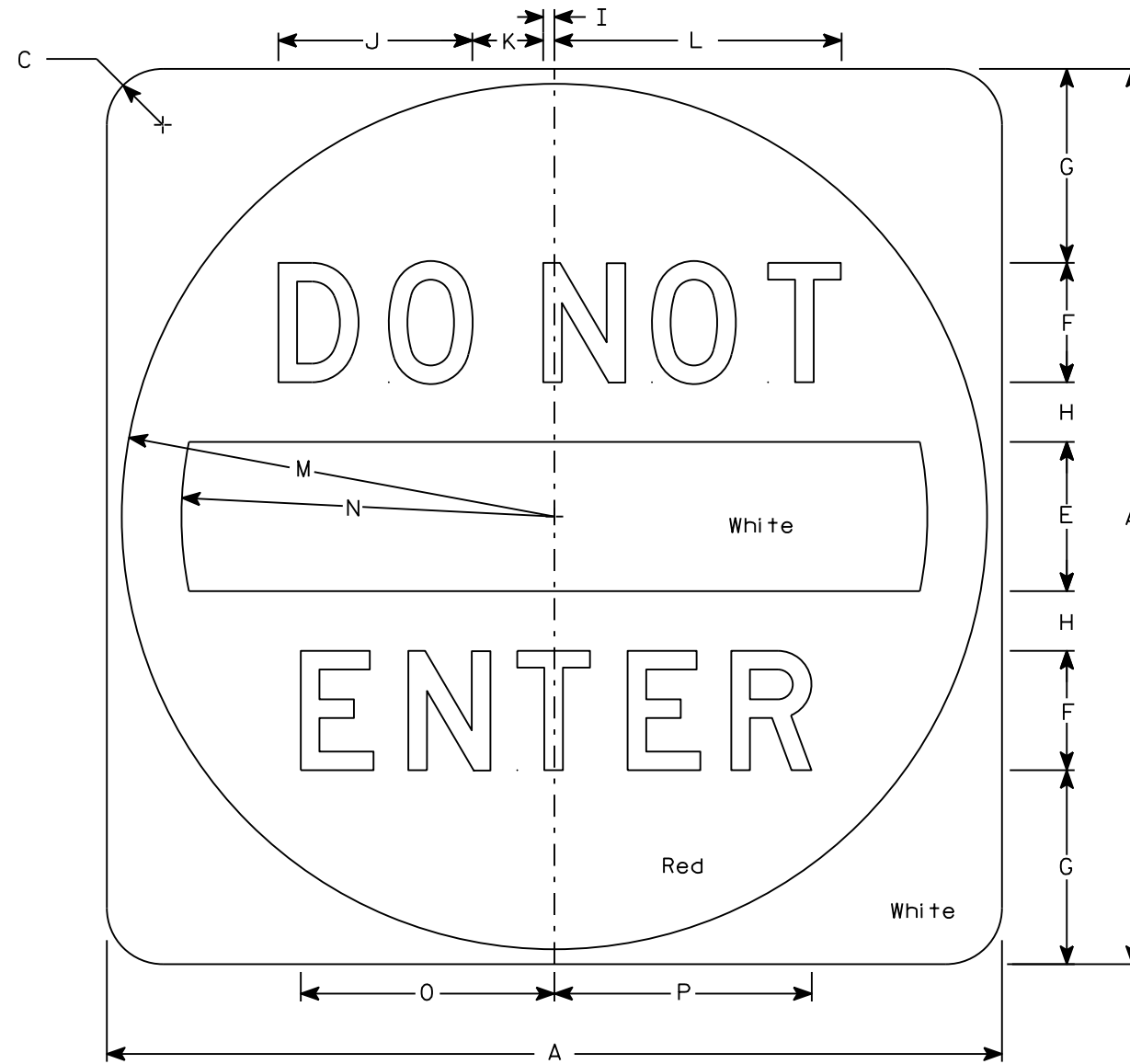

R5-1

7

7

SIZE	A	B	C	D	E	F	G	H	I	J	K	L	M	N	O	P	Q	R	S	T	U	V	W	X	Y	Z	Area sq. ft.
1																											
2S	30		1 7/8		5	4	6 1/2	2	3/8	6 1/2	2 3/8	9 5/8	14 1/2	12 1/2	8 1/2	8 5/8											6.25
2M	36		2 1/4		6	5	7 1/2	2 1/2	1/2	8 1/8	3	12 1/8	17 1/2	15	10 5/8	10 3/4											9.0
3	36		2 1/4		6	5	7 1/2	2 1/2	1/2	8 1/8	3	12 1/8	17 1/2	15	10 5/8	10 3/4											9.0
4	36		2 1/4		6	5	7 1/2	2 1/2	1/2	8 1/8	3	12 1/8	17 1/2	15	10 5/8	10 3/4											9.0
5	48		3		8	6	11	3	5/8	9 3/4	3 5/8	14 1/2	23 1/2	20	12 3/4	12 7/8											16.0

STANDARD SIGN  
R5-1

WISCONSIN DEPT OF TRANSPORTATION

APPROVED *Matthew R. Rauch*  
for State Traffic Engineer

DATE 3/15/18 PLATE NO. R5-1.16

PROJECT NO: \_\_\_\_\_ HWY: \_\_\_\_\_ COUNTY: \_\_\_\_\_ SHEET NO: \_\_\_\_\_ **E**

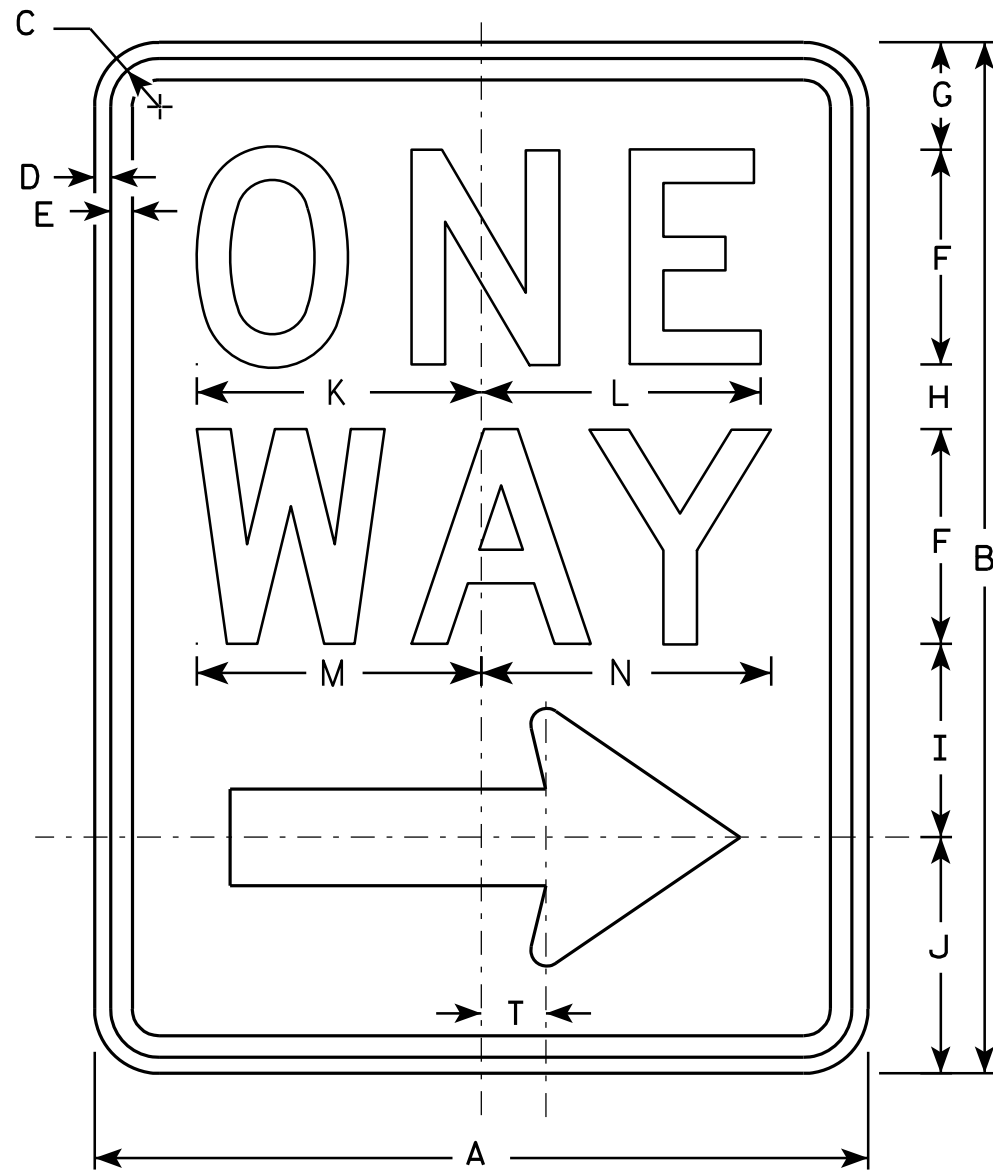

R6-2R

**NOTES**

1. Sign is Type II - Type H Reflective - reference WIS DOT Standard Specification for HIGHWAY and STRUCTURE CONSTRUCTION latest edition.
2. Color:  
Background - White  
Message - Black
3. Message Series - D
4. Corners may be square or rounded when base material is plywood but borders shall be rounded as shown. When base material is metal, the corners and borders shall be rounded.
5. R6-2L same as R6-2R except arrow points to the left.

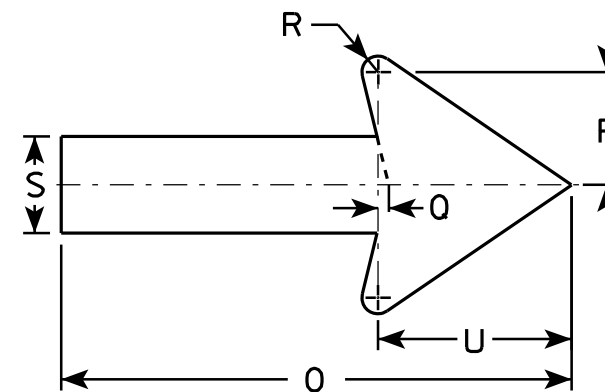

7

7

SIZE	A	B	C	D	E	F	G	H	I	J	K	L	M	N	O	P	Q	R	S	T	U	V	W	X	Y	Z
1	18	24	1 1/8	3/8	1/2	5	2 1/2	1 1/2	4 1/2	5 1/2	6 5/8	6 1/2	6 5/8	6 3/4	11 7/8	2 5/8	1/4	3/8	2 1/4	1 1/2	4 1/2					
2S	24	30	1 1/8	3/8	1/2	6	3	2 1/2	5 1/2	7	8 1/8	8 1/8	8 1/2	8 5/8	16	3 1/2	3/8	1/2	3	2	6					
2M	30	36	1 3/8	1/2	5/8	8	2 1/2	2 5/8	6 7/8	8	10 1/2	10 1/2	11 1/4	11 1/4	20	4 3/8	1/2	5/8	3 3/4	2 1/2	7 1/2					
3	36	48	1 7/8	1/2	5/8	10	5 1/4	3 1/4	9	10 1/2	12 3/4	12 3/4	13 1/4	13 1/2	24	5 5/8	1/2	3/4	4 3/4	3	9					
4	36	48	1 7/8	1/2	5/8	10	5 1/4	3 1/4	9	10 1/2	12 3/4	12 3/4	13 1/4	13 1/2	24	5 5/8	1/2	3/4	4 3/4	3	9					
5																										

**STANDARD SIGN**  
**R6-2 R&L**

*WISCONSIN DEPT OF TRANSPORTATION*

APPROVED *Matthew R. Rauch*  
For State Traffic Engineer

DATE 11/2/10 PLATE NO. R6-2.8

PROJECT NO: \_\_\_\_\_ HWY: \_\_\_\_\_ COUNTY: \_\_\_\_\_ SHEET NO: **E**

NOTES

1. Sign is Type II - Type H Reflective - reference WIS DOT Standard Specification for HIGHWAY and STRUCTURE CONSTRUCTION latest edition.
2. Color:  
Background - White  
Message - Black
3. Message Series - C
4. Corners may be square or rounded when base material is plywood but borders shall be rounded as shown. When base material is metal, the corners and borders shall be rounded.

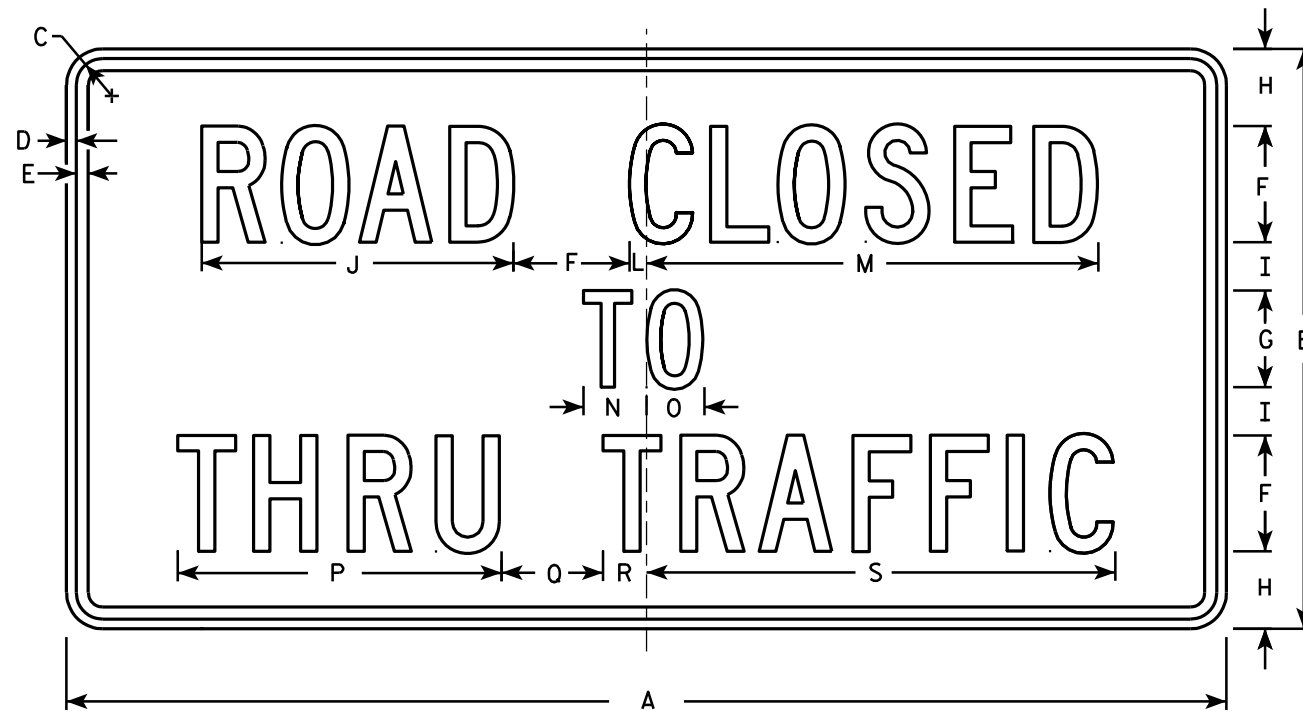

R11-4

7

7

SIZE	A	B	C	D	E	F	G	H	I	J	K	L	M	N	O	P	Q	R	S	T	U	V	W	X	Y	Z	Area sq. ft.
1																											
2S	60	30	1 3/8	1/2	5/8	6	5	4	2 1/2	16 1/8		7/8	23 3/8	3 1/4	3	16 3/4	5 1/4	2 1/4	24 1/4								12.5
2M	60	30	1 3/8	1/2	5/8	6	5	4	2 1/2	16 1/8		7/8	23 3/8	3 1/4	3	16 3/4	5 1/4	2 1/4	24 1/4								12.5
3																											
4																											
5																											

**STANDARD SIGN**  
R11 - 4

---

*WISCONSIN DEPT OF TRANSPORTATION*

APPROVED *Matthew R. Raush*  
for State Traffic Engineer

DATE 4/1/11 PLATE NO. R11-4.3

PROJECT NO: \_\_\_\_\_ HWY: \_\_\_\_\_ COUNTY: \_\_\_\_\_ SHEET NO: \_\_\_\_\_ E

NOTES

1. Sign is Type II - Type F Reflective
2. Color:  
Background - Yellow  
Message - Black

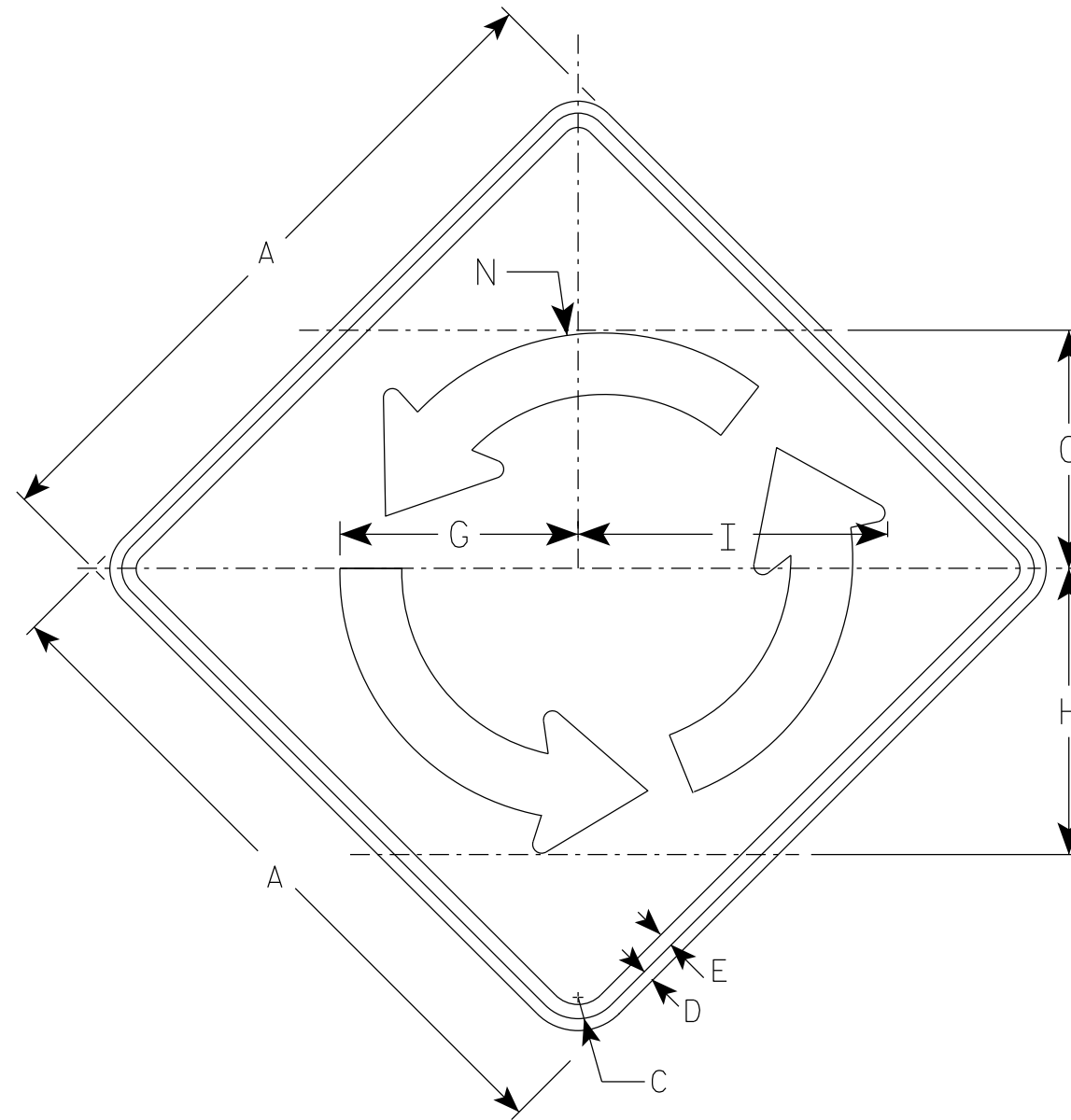

W2-6

Arrow Detail

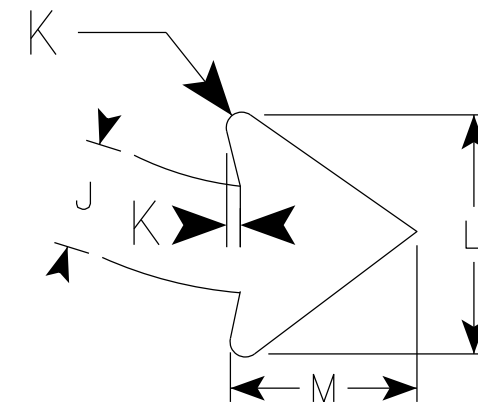

SIZE	A	B	C	D	E	F	G	H	I	J	K	L	M	N	O	P	Q	R	S	T	U	V	W	X	Area sq. ft.
1																									
2S	30		1 3/8	1/2	5/8		10 3/8	12 1/2	13 1/2	2 3/4	3/8	6	4 3/4	11 1/8											6.25
2M	30		1 3/8	1/2	5/8		10 3/8	12 1/2	13 1/2	2 3/4	3/8	6	4 3/4	11 1/8											6.25
3	36		1 5/8	5/8	3/4		12 1/2	15	16 1/4	3 1/4	1/2	7 3/8	5 3/4	13 3/8											9.00
4	48		2 1/4	3/4	1		16 5/8	20	16 1/4	4 3/8	5/8	9 3/4	7 5/8	17 7/8											16.0
5																									

STANDARD SIGN  
W2-6

WISCONSIN DEPT OF TRANSPORTATION

APPROVED *Matthew R. Rauch*  
for State Traffic Engineer

DATE 3/24/21 PLATE NO. W2-6.7

PROJECT NO:

SHEET NO:

E

7

7



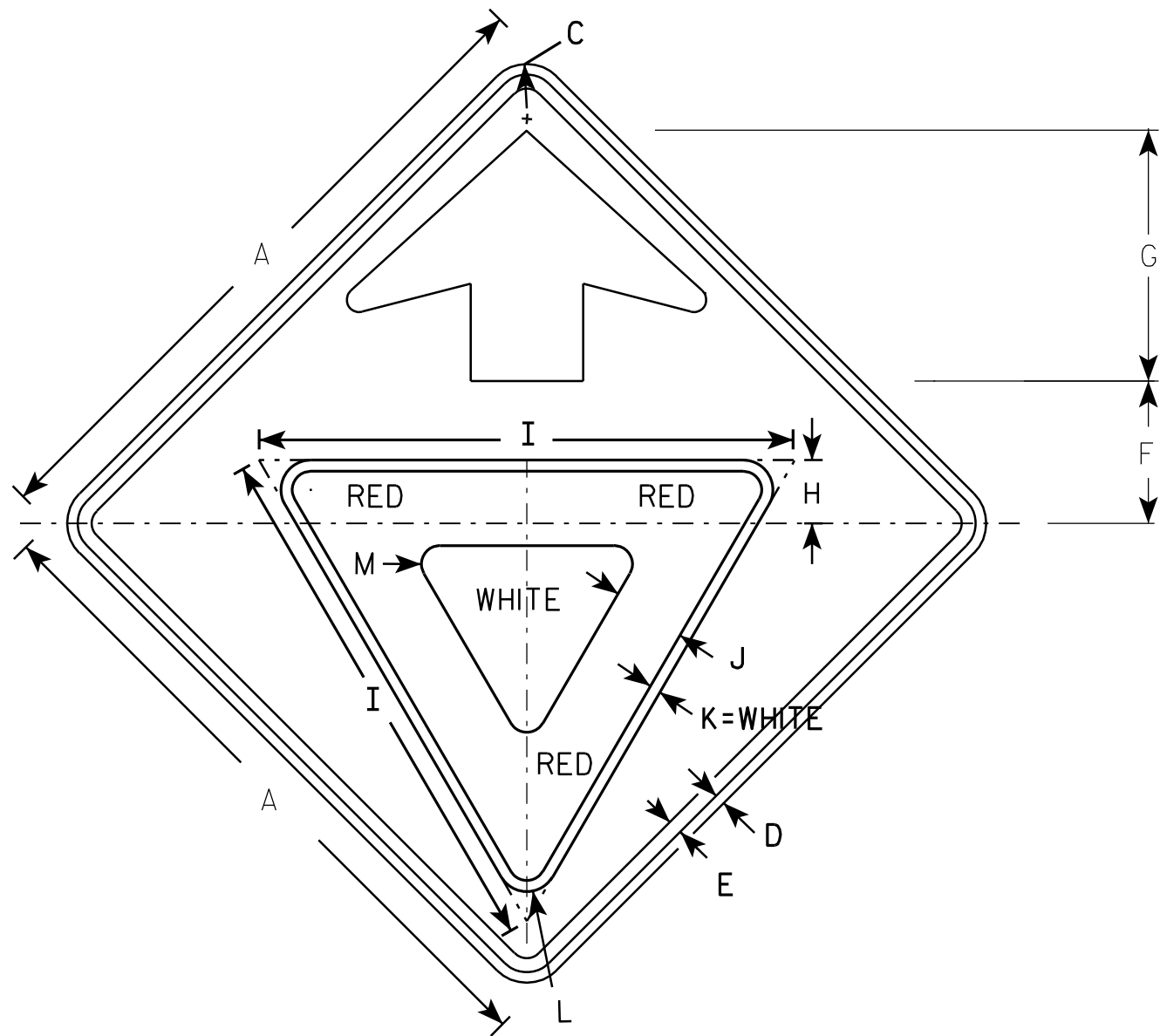

W3-2

NOTES

1. All Signs Type II - Type F Reflective - reference WIS DOT Standard Specification for HIGHWAY and STRUCTURE CONSTRUCTION latest edition.
2. Color:  
 Background - YELLOW  
 Arrow & Border - BLACK  
 Yield Symbol - WHITE BORDER ON RED BACKGROUND

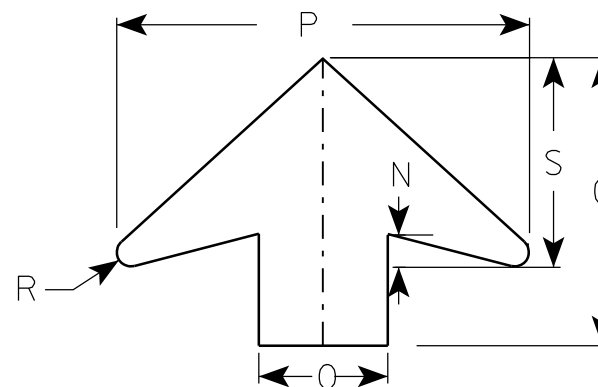

ARROW DETAIL

7

7

SIZE	A	B	C	D	E	F	G	H	I	J	K	L	M	N	O	P	Q	R	S	T	U	V	W	X	Y	Z	Area sq. ft.
1	30		1 3/8	1/2	5/8	6 1/4	11 1/4	3	25	3 3/8	1/2	1 3/8	7/8	1 1/4	5	16		1/2	8								6.25
2S	36		1 5/8	5/8	3/4	7 1/2	13 1/2	3 3/8	28	3 3/4	5/8	1 1/2	1	1 5/8	6	19 1/4		5/8	9 3/4								9.0
2M	36		1 5/8	5/8	3/4	7 1/2	13 1/2	3 3/8	28	3 3/4	5/8	1 1/2	1	1 5/8	6	19 1/4		5/8	9 3/4								9.0
3	36		1 5/8	5/8	3/4	7 1/2	13 1/2	3 3/8	28	3 3/4	5/8	1 1/2	1	1 5/8	6	19 1/4		5/8	9 3/4								9.0
4	48		2 1/4	3/4	1	10	17 7/8	4 1/2	38	5	3/4	2 1/8	1 3/8	2	8	25 5/8		7/8	13								16.0
5	48		2 1/4	3/4	1	10	17 7/8	4 1/2	38	5	3/4	2 1/8	1 3/8	2	8	25 5/8		7/8	13								16.0

**STANDARD SIGN**  
W3-2

WISCONSIN DEPT OF TRANSPORTATION

APPROVED *Matthew R. Rauch*  
for State Traffic Engineer

DATE 6/7/10 PLATE NO. W3-2..9

PROJECT NO: \_\_\_\_\_ SHEET NO: \_\_\_\_\_ E

NOTES

1. Sign is Type II - Type F Reflective - reference WIS DOT Standard Specification for HIGHWAY and STRUCTURE CONSTRUCTION latest edition.
2. Color:  
Background - Yellow
3. Corners may be square or rounded when base material is plywood. When base material is metal the corners shall be rounded.

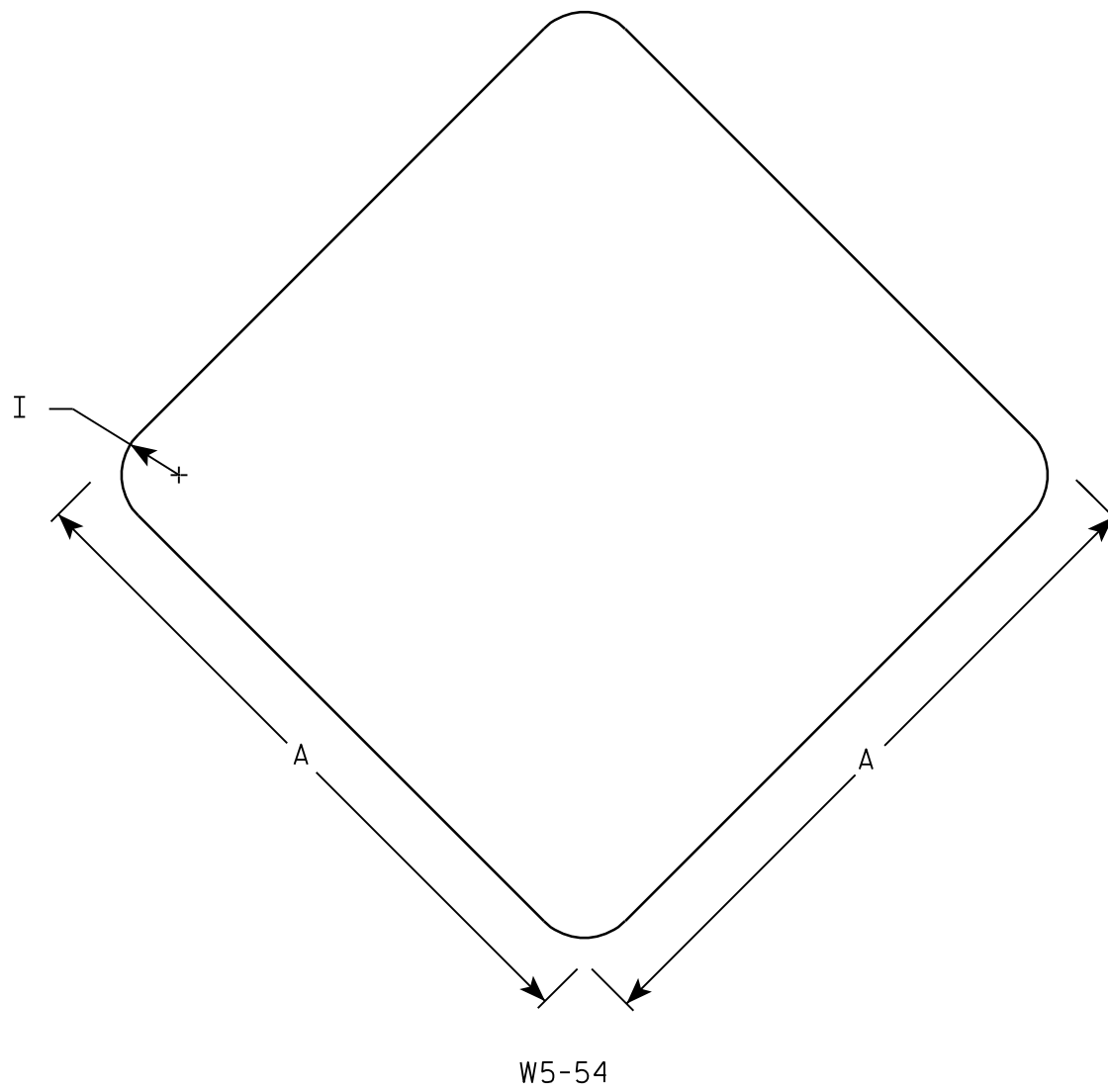

7

7

SIZE	A	B	C	D	E	F	G	H	I	J	K	L	M	N	O	P	Q	R	S	T	U	V	W	X	Y	Z	Area sq. ft.
1	12								1																		1.0
2S	18								1 1/2																		2.25
2M	18								1 1/2																		2.25
3																											
4																											
5																											

<b>STANDARD SIGN</b>	
W5-54	
<small>WISCONSIN DEPT OF TRANSPORTATION</small>	
<small>APPROVED</small>	<i>Matthew R Rauch</i> <small>For State Traffic Engineer</small>
<small>DATE</small> 11/3/10	<small>PLATE NO.</small> W5-54.8

PROJECT NO:	HWY:	COUNTY:	SHEET NO: <b>E</b>
-------------	------	---------	--------------------

NOTES

1. Sign is Type II - Type F Reflective - reference WIS DOT Standard Specification for HIGHWAY and STRUCTURE CONSTRUCTION latest edition.
2. Color:  
Background - Yellow  
Message - Black
3. Corners may be square or rounded when base material is plywood but borders shall be rounded as shown. When base material is metal, the corners and borders shall be rounded.

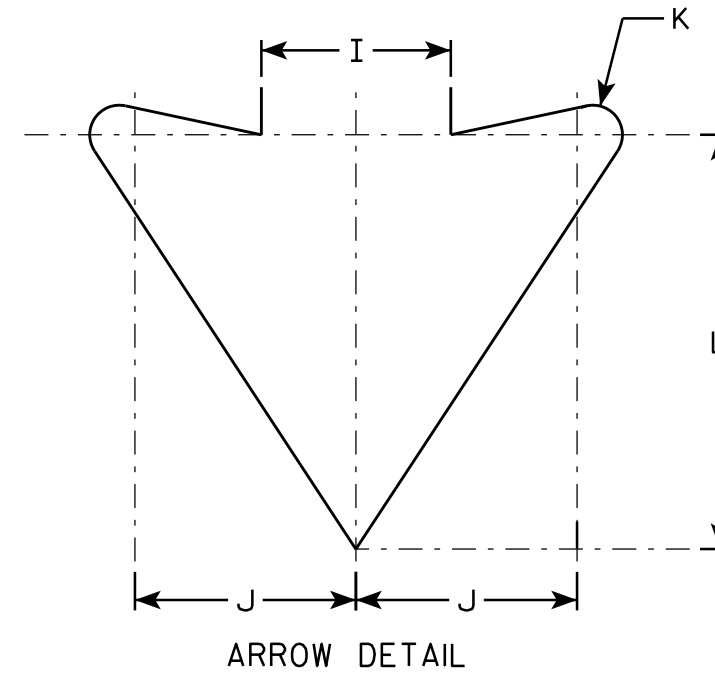
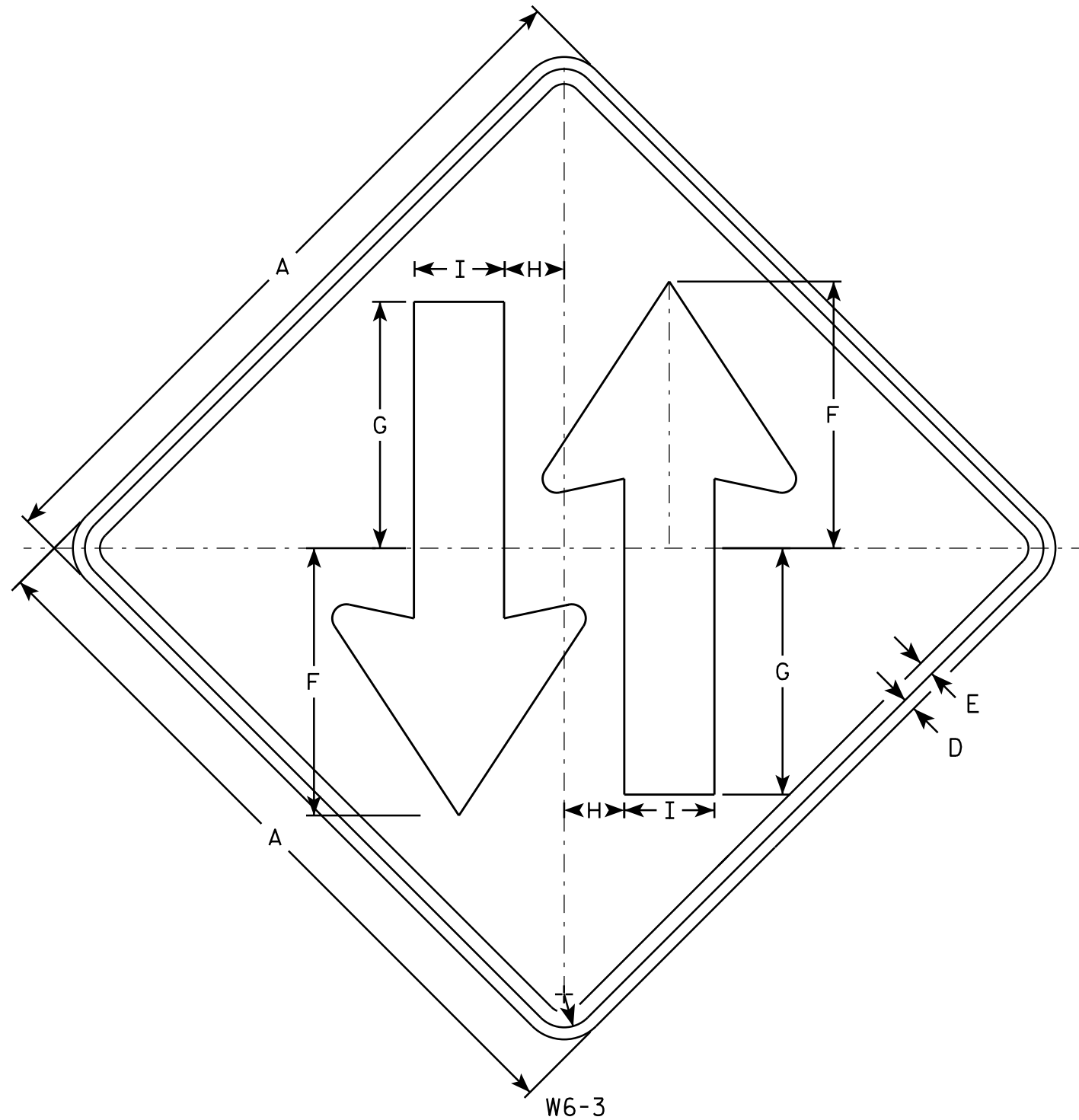

ARROW DETAIL

SIZE	A	B	C	D	E	F	G	H	I	J	K	L	M	N	O	P	Q	R	S	T	U	V	W	X	Y	Z	Area sq. ft.
1	30		1 3/8	1/2	5/8	11 1/8	10 1/4	2 1/2	3 3/4	4 3/8	5/8	8 1/4															6.25
2S	36		1 5/8	5/8	3/4	13 3/8	12 1/4	3	4 1/2	5 1/4	3/4	9 7/8															9.0
2M	36		1 5/8	5/8	3/4	13 3/8	12 1/4	3	4 1/2	5 1/4	3/4	9 7/8															9.0
3																											
4	48		2 1/4	3/4	1	17 3/4	16 3/8	4	6	7	1	13 1/8															16.0
5	48		2 1/4	3/4	1	17 3/4	16 3/8	4	6	7	1	13 1/8															16.0

**STANDARD SIGN**  
W6-3

WISCONSIN DEPT OF TRANSPORTATION

APPROVED *Matthew R. Raub*  
For State Traffic Engineer

DATE 3/10/16 PLATE NO. W6-3.11

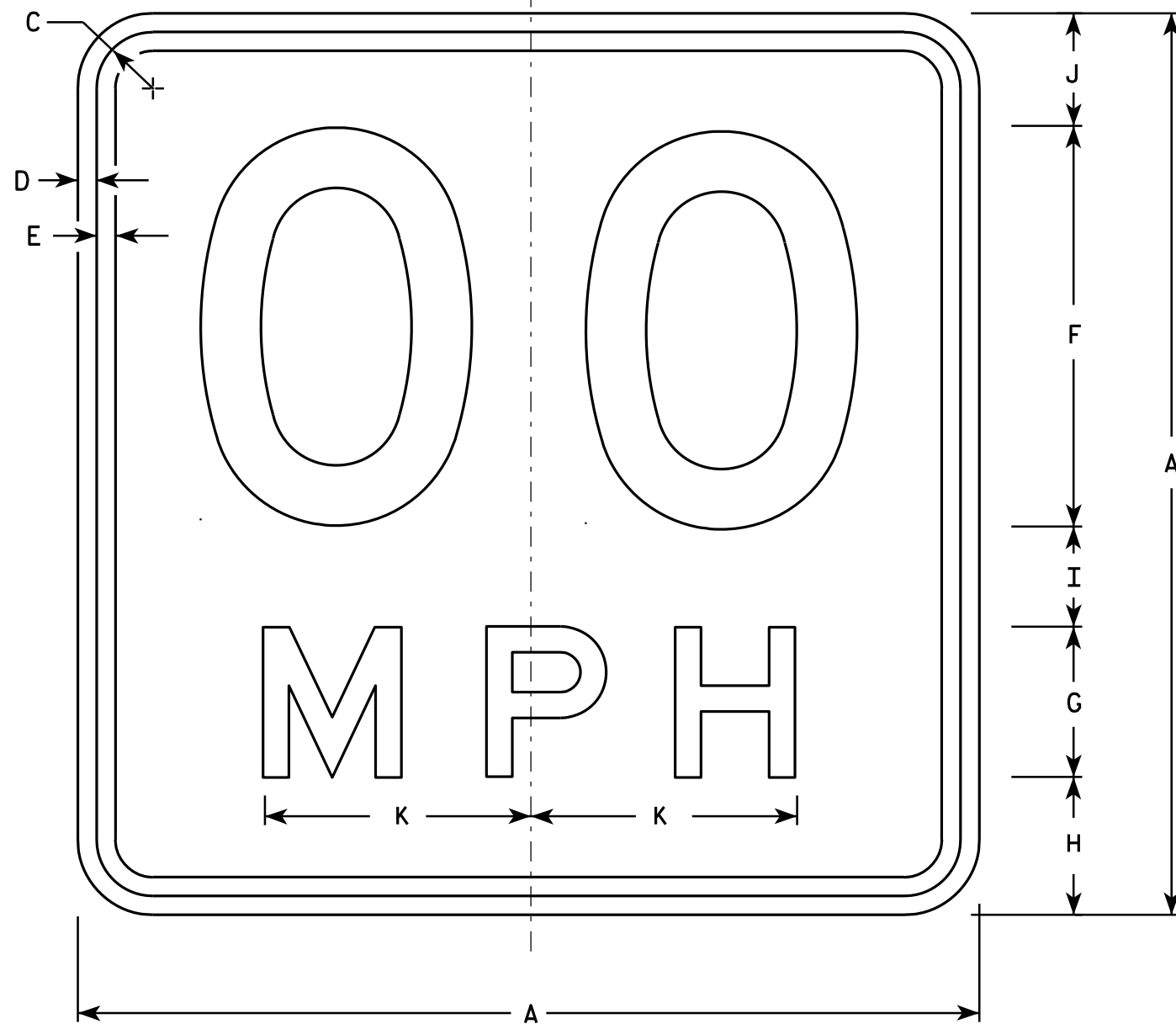

**NOTES**

1. Sign is Type II - Type F Reflective - reference WIS DOT Standard Specification for HIGHWAY and STRUCTURE CONSTRUCTION latest edition.
2. Color:  
Background - Yellow  
Message - Black
3. Message Series - See Note 6
4. Corners may be square or rounded when base material is plywood but borders shall be rounded as shown. When base material is metal, the corners and borders shall be rounded.
5. Substitute appropriate numerals and optically space about centerline to achieve proper balance.
6. Line 1 is Series D  
Line 2 is Series E

W13-1

\* For 30" x 30" Warning Signs, use 18" x 18" W13-1 signs.  
For 36" x 36" Warning Signs, use 24" x 24" W13-1 signs.

SIZE	A	B	C	D	E	F	G	H	I	J	K	L	M	N	O	P	Q	R	S	T	U	V	W	X	Y	Z	Area sq. ft.
1	18		1 1/8	3/8	3/8	8	3	2 3/4	2	2 1/4	5 3/8																2.25
* 2S	18		1 1/8	3/8	3/8	8	3	2 3/4	2	2 1/4	5 3/8																2.25
* 2M	18		1 1/8	3/8	3/8	8	3	2 3/4	2	2 1/4	5 3/8																2.25
3	24		1 1/8	3/8	1/2	10	4	4	2 3/4	3 1/4	6 5/8																4.00
4	36		1 5/8	5/8	3/4	16	6	5 1/2	4	4 1/2	10 5/8																9.00
5	36		1 5/8	5/8	3/4	16	6	5 1/2	4	4 1/2	10 5/8																9.00

STANDARD SIGN  
W13-1

WISCONSIN DEPT OF TRANSPORTATION  
APPROVED *Matthew R. Rauch*  
For State Traffic Engineer

DATE 5/31/12 PLATE NO. W13-1.16

PROJECT NO:

HWY:

COUNTY:

SHEET NO:

E

NOTES

1. Sign is Type II - Type F Reflective
2. Color:  
Background - Yellow  
Message - Black
3. Message Series - Lines 1 and 2 are Series D.  
Line 3 is series C.
4. Corners and borders shall be rounded on all base materials for this sign.

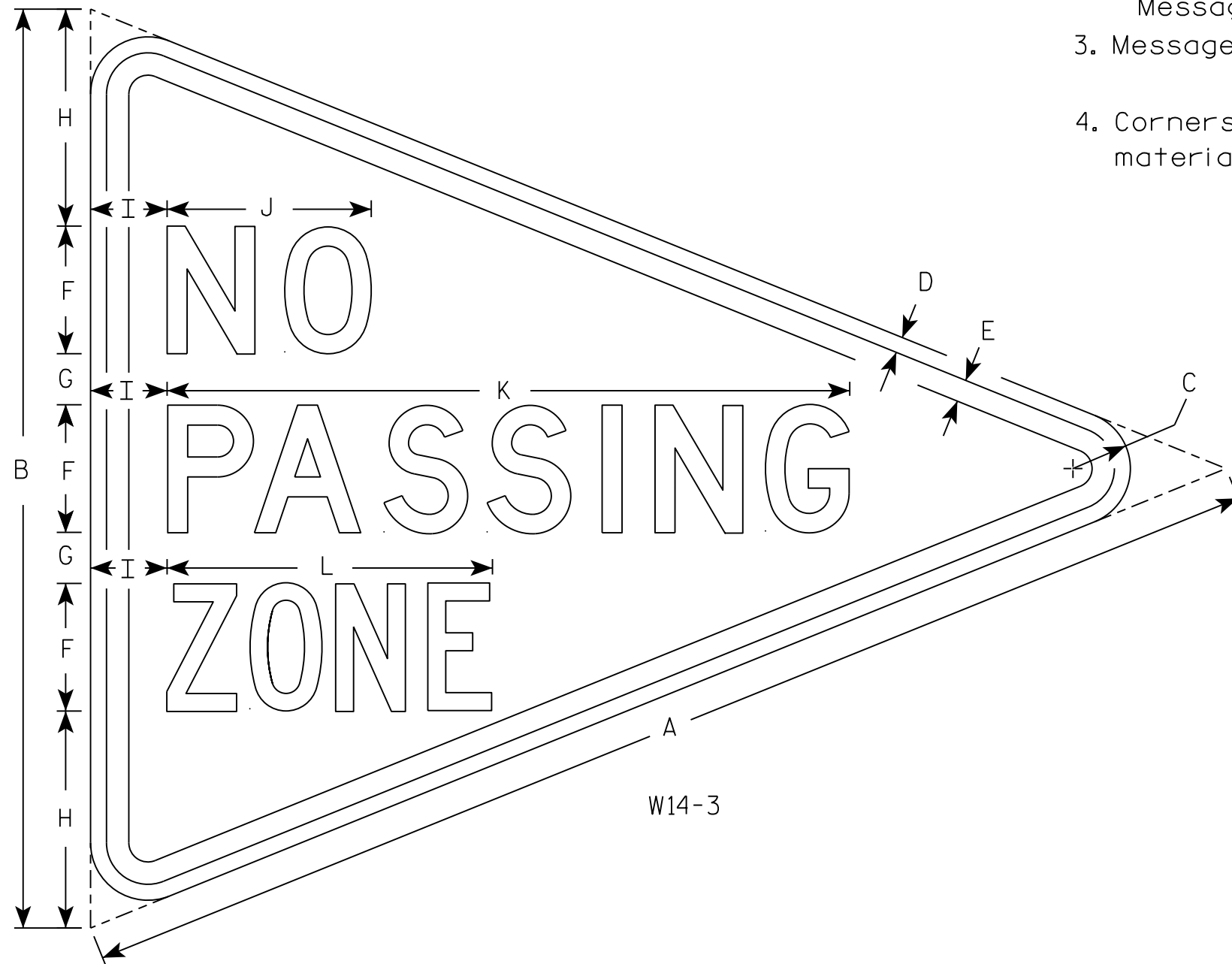

7

7

SIZE	A	B	C	D	E	F	G	H	I	J	K	L	M	N	O	P	Q	R	S	T	U	V	W	X	Y	Z	Area sq. ft.
1																											
2S	48	36	2 1/4	5/8	7/8	5	2	8 1/2	3	8	26 3/4	12 3/4															5.56
2M																											
3																											
4																											
5																											

STANDARD SIGN  
W14-3

WISCONSIN DEPT OF TRANSPORTATION

APPROVED *Matthew R. Rauch*  
for State Traffic Engineer

DATE 3/21/17 PLATE NO. W14-3.10

PROJECT NO: \_\_\_\_\_ HWY: \_\_\_\_\_ COUNTY: \_\_\_\_\_ SHEET NO: **E**

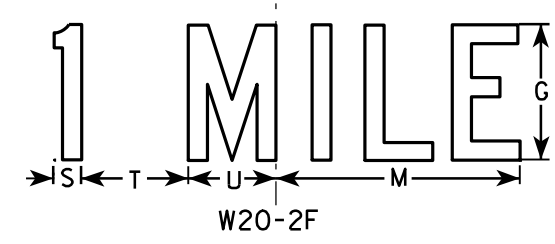
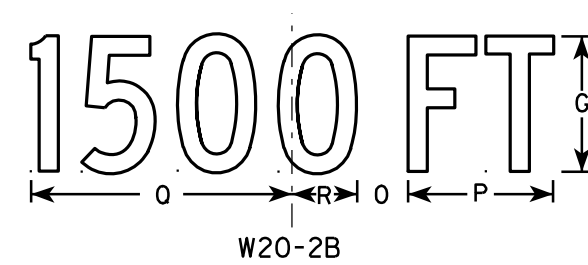
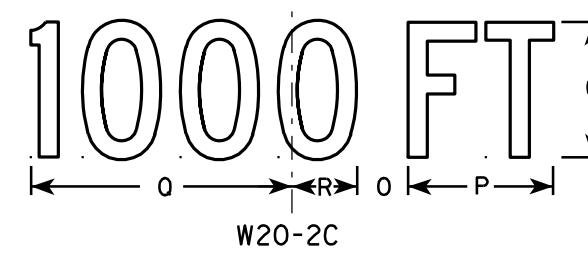
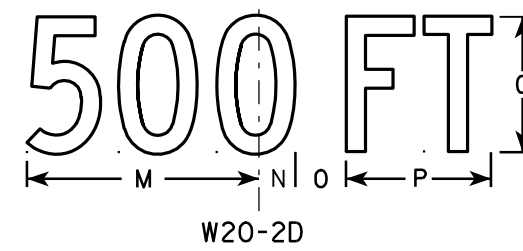
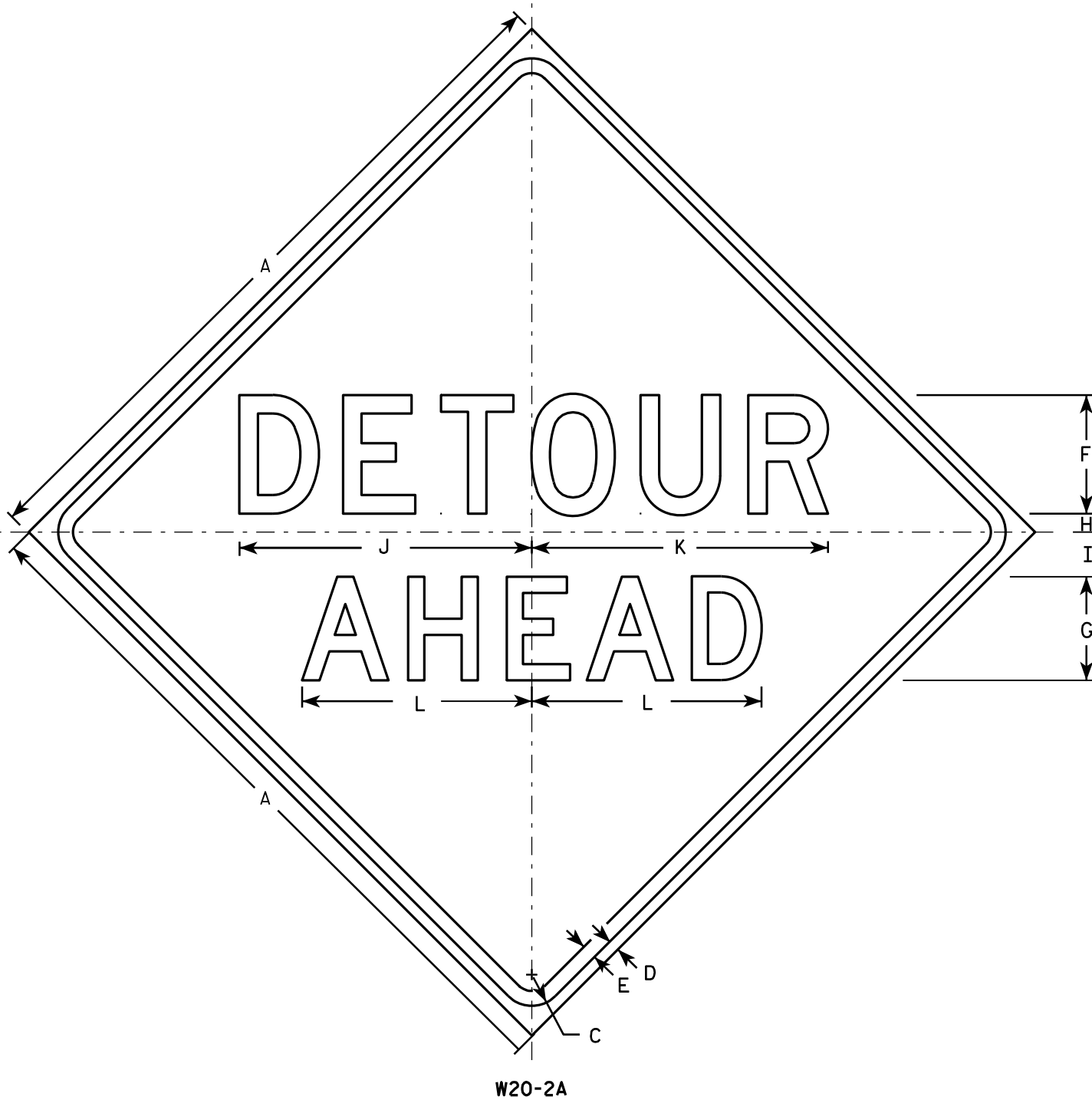

**NOTES**

1. Sign is Type II - Type F Reflective - reference WIS DOT Standard Specification for HIGHWAY and STRUCTURE CONSTRUCTION latest edition.
2. Color:  
Background - Orange  
Message - Black
3. Message Series - See note 5
4. Corners may be square or rounded when base material is plywood but borders shall be rounded as shown. When base material is metal, the corners and borders shall be rounded.
5. Line 1 is Series D.  
Line 2 is Series D for AHEAD and Series C for all other distances.

7

7

SIZE	A	B	C	D	E	F	G	H	I	J	K	L	M	N	O	P	Q	R	S	T	U	V	W	X	Y	Z	Area sq. ft.
1	36		1 5/8	5/8	3/4	6	5	1	2 1/4	14 3/4	15	11 5/8	9	1 3/8	1 7/8	5 5/8	10 1/8	2 1/2	1 1/8	4 1/2	3 1/2	8	1 3/4	10 3/4			9.0
2S	48		2 1/4	3/4	1	8	7	1 1/4	3	19 3/4	20	15 1/2	12	1 7/8	2 5/8	7 1/2	13 1/2	3 3/8	1 1/2	6	4 5/8	10 5/8	2 3/8	14 3/8			16.0
2M	48		2 1/4	3/4	1	8	7	1 1/4	3	19 3/4	20	15 1/2	12	1 7/8	2 5/8	7 1/2	13 1/2	3 3/8	1 1/2	6	4 5/8	10 5/8	2 3/8	14 3/8			16.0
3	48		2 1/4	3/4	1	8	7	1 1/4	3	19 3/4	20	15 1/2	12	1 7/8	2 5/8	7 1/2	13 1/2	3 3/8	1 1/2	6	4 5/8	10 5/8	2 3/8	14 3/8			16.0
4	48		2 1/4	3/4	1	8	7	1 1/4	3	19 3/4	20	15 1/2	12	1 7/8	2 5/8	7 1/2	13 1/2	3 3/8	1 1/2	6	4 5/8	10 5/8	2 3/8	14 3/8			16.0
5	48		2 1/4	3/4	1	8	7	1 1/4	3	19 3/4	20	15 1/2	12	1 7/8	2 5/8	7 1/2	13 1/2	3 3/8	1 1/2	6	4 5/8	10 5/8	2 3/8	14 3/8			16.0

STANDARD SIGN  
W20-2A, B, C, D, F & G

WISCONSIN DEPT OF TRANSPORTATION

APPROVED *Matthew R. Raub*  
for State Traffic Engineer

DATE 3/18/11 PLATE NO. W20-2.6

PROJECT NO: \_\_\_\_\_ HWY: \_\_\_\_\_ COUNTY: \_\_\_\_\_ SHEET NO: \_\_\_\_\_ E

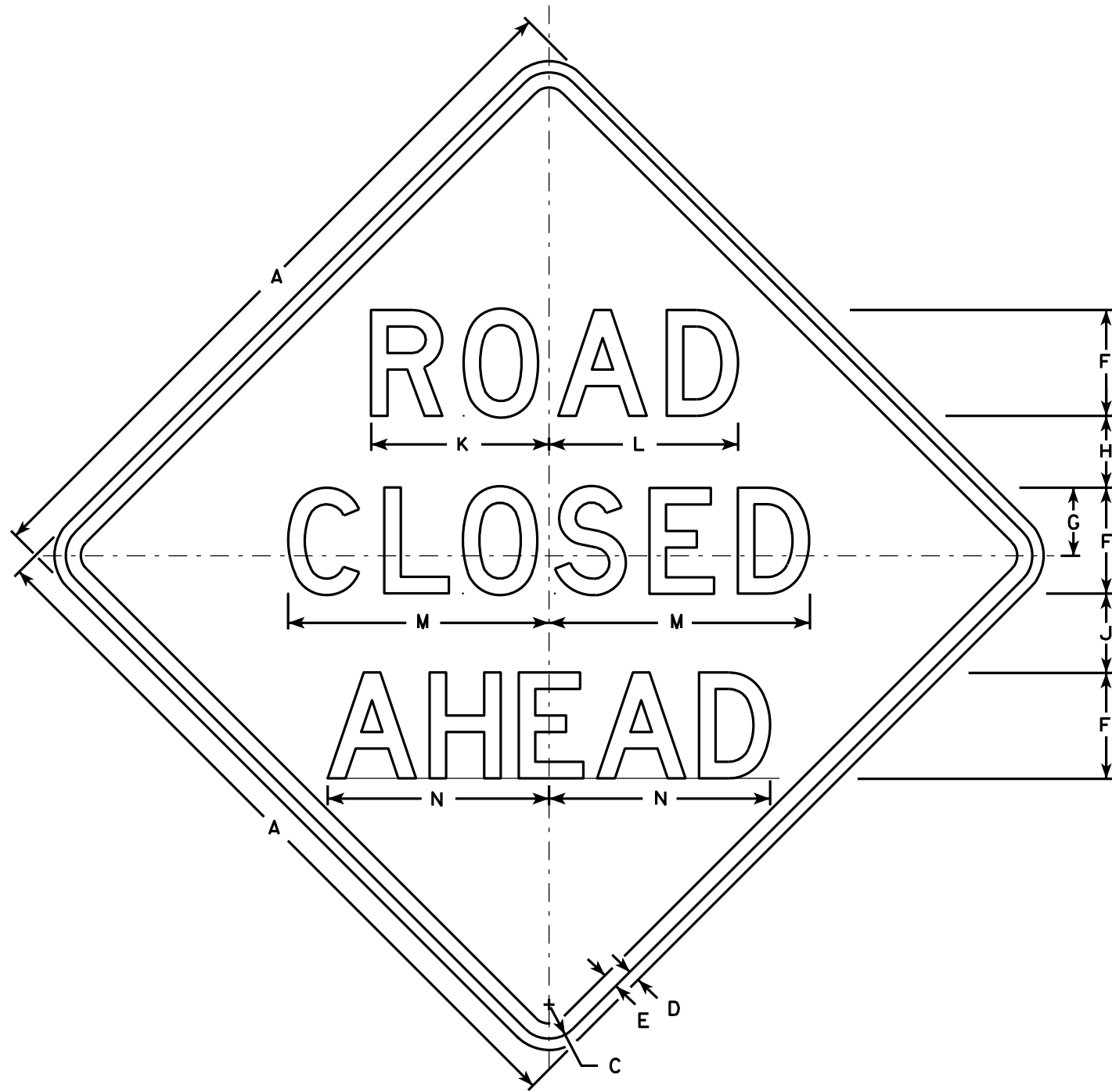

W20-3A

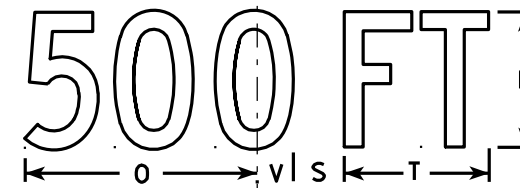

W20-3D

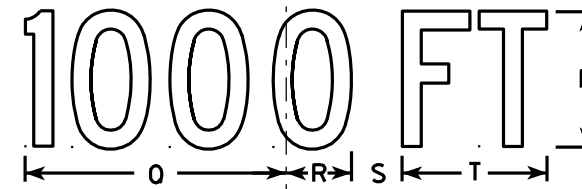

W20-3C

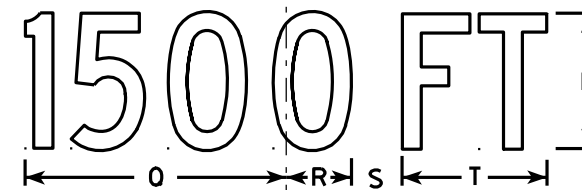

W20-3B

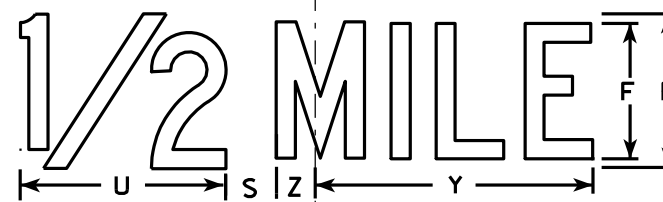

W20-3G



W20-3F

**NOTES**

1. Sign is Type II - Type F Reflective - reference WIS DOT Standard Specification for HIGHWAY and STRUCTURE CONSTRUCTION latest edition.
2. Color:  
Background - Orange  
Message - Black
3. Message Series - see note 5
4. Corners may be square or rounded when base material is plywood but borders shall be rounded as shown. When base material is metal, the corners and borders shall be rounded.
5. Lines 1 and 2 are Series D.  
Line 3 is Series D for AHEAD and Series C for all other distances.

7

7

SIZE	A	B	C	D	E	F	G	H	I	J	K	L	M	N	O	P	Q	R	S	T	U	V	W	X	Y	Z	Area sq. ft.
1	36		1 5/8	5/8	3/4	5	3 3/8	3 1/2	1 1/8	4	8 3/8	8 7/8	12 1/2	11	9	6	10 1/8	2 1/2	1 7/8	5 5/8	8	1 3/8	4 1/2	3 1/2	10 3/4	1 3/4	9.0
2S	48		2 1/4	3/4	1	7	4 1/2	4 3/4	1 1/2	5 1/4	11 3/4	12 1/2	17 1/4	14 5/8	12	8	13 1/2	3 3/8	2 5/8	7 1/2	10 5/8	1 7/8	6	4 5/8	14 3/8	2 3/8	16.0
2M	48		2 1/4	3/4	1	7	4 1/2	4 3/4	1 1/2	5 1/4	11 3/4	12 1/2	17 1/4	14 5/8	12	8	13 1/2	3 3/8	2 5/8	7 1/2	10 5/8	1 7/8	6	4 5/8	14 3/8	2 3/8	16.0
3	48		2 1/4	3/4	1	7	4 1/2	4 3/4	1 1/2	5 1/4	11 3/4	12 1/2	17 1/4	14 5/8	12	8	13 1/2	3 3/8	2 5/8	7 1/2	10 5/8	1 7/8	6	4 5/8	14 3/8	2 3/8	16.0
4	48		2 1/4	3/4	1	7	4 1/2	4 3/4	1 1/2	5 1/4	11 3/4	12 1/2	17 1/4	14 5/8	12	8	13 1/2	3 3/8	2 5/8	7 1/2	10 5/8	1 7/8	6	4 5/8	14 3/8	2 3/8	16.0
5	48		2 1/4	3/4	1	7	4 1/2	4 3/4	1 1/2	5 1/4	11 3/4	12 1/2	17 1/4	14 5/8	12	8	13 1/2	3 3/8	2 5/8	7 1/2	10 5/8	1 7/8	6	4 5/8	14 3/8	2 3/8	16.0

**STANDARD SIGN**  
W20-3A, B, C, D, F & G

WISCONSIN DEPT OF TRANSPORTATION

APPROVED *Matthew R. Rauch*  
For State Traffic Engineer

DATE 3/18/11 PLATE NO. W20-3.7

ALIGNMENT - CTH U NB

STATION	DISTANCE	AREA (SF)				INCREMENTAL VOL (CY) (UNADJUSTED)				CUMULATIVE VOL (CY)			
		CUT	SALVAGED/UNUSABLE PAVEMENT MATERIAL	FILL	EBS	CUT	SALVAGED/UNUSABLE PAVEMENT MATERIAL	FILL	EBS	CUT	EXPANDED FILL	EXPANDED EBS BACKFILL	MASS ORDINATE
256+84.42	0.00	26.24	6.00	0.00	24.27	0	0	0	0	0	0	0	0
257+00.00	15.58	26.79	6.24	33.85	25.55	15	4	10	14	15	12	18	-1
257+50.00	50.00	26.70	7.02	14.02	29.53	50	12	44	51	65	62	85	-13
258+00.00	50.00	30.38	7.98	50.89	33.00	53	14	60	58	118	131	160	-43
258+50.00	50.00	37.43	9.27	40.69	37.35	63	16	85	65	181	229	244	-94
259+00.00	50.00	61.51	10.55	25.78	41.70	92	18	62	73	273	300	339	-91
259+50.00	50.00	83.56	10.31	20.97	22.54	134	19	43	59	407	350	416	-26
260+00.00	50.00	91.41	11.67	12.63	22.54	162	20	31	42	569	385	471	81
260+50.00	50.00	80.92	12.08	8.90	43.03	160	22	20	61	729	408	550	196
261+00.00	50.00	65.37	11.95	12.46	35.94	135	22	20	73	864	431	645	286
261+37.36	37.36	25.23	13.03	32.29	37.43	63	17	31	51	927	467	711	296
263+03.42	0.00	49.49	6.03	54.85	11.34	0	0	0	0	927	467	711	296
263+50.00	46.58	80.07	3.12	22.58	23.70	112	8	67	30	1,039	544	750	323
264+00.00	50.00	86.58	5.24	15.69	22.42	154	8	35	43	1,193	584	806	429
264+50.00	50.00	96.64	7.56	9.66	29.93	170	12	23	48	1,363	611	868	560
265+00.00	50.00	101.25	8.27	4.26	35.19	183	15	13	60	1,546	626	946	713
265+50.00	50.00	92.77	8.66	3.44	39.53	180	16	7	69	1,726	634	1,036	869
266+00.00	50.00	59.92	7.24	4.45	34.21	141	15	7	68	1,867	642	1,125	987
266+50.00	50.00	35.02	5.88	3.76	28.38	88	12	8	58	1,955	651	1,200	1,054
267+00.00	50.00	26.34	5.37	3.08	22.08	57	10	6	47	2,012	658	1,261	1,094
267+29.30	29.30	26.44	0.00	1.01	21.56	29	3	2	24	2,041	660	1,292	1,118

NOTES:

- 1 - CUT INCLUDES SALVAGED/UNUSABLE PAVEMENT MATERIAL
- 2 - SALVAGED/UNUSABLE PAVEMENT MATERIAL, THIS DOES NOT SHOW UP IN CROSS SECTIONS
- 3 - FILL, DOES NOT INCLUDE UNUSABLE PAVEMENT EXC VOLUME
- 5 - EXPANDED EBS, WILL BE BACKFILLED WITH SELECT CRUSHED MATERIAL
- 6 - MASS ORDINATE DOES NOT ACCOUNT FOR EBS



ALIGNMENT - CTH U SB

STATION	DISTANCE	AREA (SF)				INCREMENTAL VOL (CY) (UNADJUSTED)				CUMULATIVE VOL (CY)			MASS ORDINATE
		CUT	SALVAGED/UNUSABLE PAVEMENT MATERIAL	FILL	EBS	CUT	SALVAGED/UNUSABLE PAVEMENT MATERIAL	FILL	EBS	CUT	EXPANDED FILL	EXPANDED EBS BACKFILL	
										1.00	1.15	1.30	
NOTE 1	NOTE 2	NOTE 3	NOTE 1	NOTE 5	NOTE 6								
256+84.42	0.00	32.17	1.25	2.14	29.87	0	0	0	0	0	0	0	0
257+00.00	15.58	31.47	6.63	3.75	29.90	18	2	2	17	18	2	22	14
257+50.00	50.00	25.57	4.59	20.99	26.67	53	10	23	52	71	29	90	30
258+00.00	50.00	29.81	3.63	14.79	26.67	51	8	33	49	122	67	153	35
258+50.00	50.00	26.84	2.32	22.20	26.67	52	6	34	49	174	106	217	42
259+00.00	50.00	23.51	1.07	30.48	26.61	47	3	49	49	221	162	281	30
259+50.00	50.00	28.57	1.33	38.19	28.70	48	2	64	51	269	236	347	2
260+00.00	50.00	32.14	0.09	30.08	28.36	56	1	63	53	325	308	416	-15
260+50.00	50.00	32.32	0.00	26.87	21.30	60	0	53	46	385	369	476	-16
261+00.00	50.00	37.79	0.00	1.87	28.83	65	0	27	46	450	400	536	18
261+49.11	49.11	24.22	0.00	27.92	21.25	56	0	27	46	506	431	595	43
263+05.82	0.00	54.59	6.06	11.96	27.63	0	0	0	0	506	431	595	43
263+50.00	44.18	75.90	8.43	0.00	44.53	107	12	10	59	613	443	672	126
264+00.00	50.00	77.79	6.27	0.00	30.04	142	14	0	69	755	443	762	254
264+50.00	50.00	86.20	4.39	0.01	30.71	152	10	0	56	907	443	835	396
265+00.00	50.00	84.60	2.93	0.41	30.35	158	7	0	57	1,065	443	909	547
265+50.00	50.00	70.18	2.30	2.55	25.61	143	5	3	52	1,208	446	976	682
266+00.00	50.00	61.08	3.70	4.56	26.03	122	6	7	48	1,330	454	1,039	790
266+50.00	50.00	52.79	6.28	2.63	29.80	105	9	7	52	1,435	462	1,106	878
267+00.00	50.00	26.70	5.93	1.52	24.87	74	11	4	51	1,509	467	1,173	936
267+37.88	37.88	27.78	0.00	0.24	23.91	38	4	1	34	1,547	468	1,217	969

NOTES:

- 1 - CUT INCLUDES SALVAGED/UNUSABLE PAVEMENT MATERIAL
- 2 - SALVAGED/UNUSABLE PAVEMENT MATERIAL, THIS DOES NOT SHOW UP IN CROSS SECTIONS
- 3 - FILL, DOES NOT INCLUDE UNUSABLE PAVEMENT EXC VOLUME
- 5 - EXPANDED EBS, WILL BE BACKFILLED WITH SELECT CRUSHED MATERIAL
- 6 - MASS ORDINATE DOES NOT ACCOUNT FOR EBS

ALIGNMENT - 7 MILE RD EB

STATION	DISTANCE	AREA (SF)				INCREMENTAL VOL (CY) (UNADJUSTED)				CUMULATIVE VOL (CY)			MASS ORDINATE
		CUT	SALVAGED/UNUSABLE PAVEMENT MATERIAL	FILL	EBS	CUT	SALVAGED/UNUSABLE PAVEMENT MATERIAL	FILL	EBS	CUT	EXPANDED FILL	EXPANDED EBS BACKFILL	
										1.00	1.15	1.30	
NOTE 1	NOTE 2	NOTE 3	NOTE 1	NOTE 5	NOTE 6								
100+00.00	0.00	22.52	5.79	0.00	18.92	0	0	0	0	0	0	0	0
100+50.00	50.00	40.12	5.67	12.32	25.47	58	11	11	41	58	13	53	34
101+00.00	50.00	45.39	5.56	13.23	25.96	79	10	24	48	137	40	116	76
101+50.00	50.00	33.25	5.45	17.73	24.12	73	10	29	46	210	74	176	105
102+00.00	50.00	26.54	6.85	22.80	27.13	55	11	38	47	265	117	237	106
102+50.00	50.00	21.08	6.73	25.43	25.86	44	13	45	49	309	169	300	85
103+00.00	50.00	14.31	5.38	31.49	21.04	33	11	53	43	342	230	356	46
103+50.00	50.00	10.04	2.51	45.16	12.85	23	7	71	31	365	312	397	-20
104+00.00	50.00	12.77	0.00	49.86	4.29	21	2	88	16	386	413	417	-102
104+13.79	22.33	16.36	0.00	40.44	8.31	12	0	37	5	398	455	424	-132
105+80.90	0.00	45.20	3.18	11.15	23.83	0	0	0	0	398	455	424	-132
106+00.00	24.76	64.27	4.47	2.58	28.34	50	4	6	24	448	462	455	-93
106+50.00	50.00	118.91	2.70	0.00	43.06	170	7	2	66	618	465	541	67
107+00.00	50.00	79.95	0.39	0.00	30.04	184	3	0	68	802	465	629	248
107+50.00	50.00	63.72	0.00	0.00	30.74	133	0	0	56	935	465	702	381
108+00.00	50.00	52.25	0.04	0.00	26.67	107	0	0	53	1,042	465	771	488
108+50.00	50.00	52.93	2.19	0.00	26.67	97	2	0	49	1,139	465	835	583
109+00.00	50.00	39.83	4.29	0.00	25.98	86	6	0	49	1,225	465	898	663
109+50.00	50.00	24.96	5.54	0.00	21.63	60	9	0	44	1,285	465	956	714
109+73.46	24.29	21.81	0.00	0.00	18.42	21	2	0	18	1,306	465	979	733

NOTES:

- 1 - CUT INCLUDES SALVAGED/UNUSABLE PAVEMENT MATERIAL
- 2 - SALVAGED/UNUSABLE PAVEMENT MATERIAL, THIS DOES NOT SHOW UP IN CROSS SECTIONS
- 3 - FILL, DOES NOT INCLUDE UNUSABLE PAVEMENT EXC VOLUME
- 5 - EXPANDED EBS, WILL BE BACKFILLED WITH SELECT CRUSHED MATERIAL
- 6 - MASS ORDINATE DOES NOT ACCOUNT FOR EBS

ALIGNMENT - 7 MILE RD WB

STATION	DISTANCE	AREA (SF)				INCREMENTAL VOL (CY) (UNADJUSTED)				CUMULATIVE VOL (CY)			MASS ORDINATE
		CUT	SALVAGED/UNUSABLE PAVEMENT MATERIAL	FILL	EBS	CUT	SALVAGED/UNUSABLE PAVEMENT MATERIAL	FILL	EBS	CUT	EXPANDED FILL	EXPANDED EBS BACKFILL	
												NOTE 1	
100+00.00	0.00	22.52	5.79	0.00	18.92	0	0	0	0	0	0	0	0
100+50.00	50.00	40.12	5.67	12.32	25.47	58	11	11	41	58	13	53	34
101+00.00	50.00	45.39	5.56	13.23	25.96	79	10	24	48	137	40	116	76
101+50.00	50.00	33.25	5.45	17.73	24.12	73	10	29	46	210	74	176	105
102+00.00	50.00	26.54	6.85	22.80	27.13	55	11	38	47	265	117	237	106
102+50.00	50.00	21.08	6.73	25.43	25.86	44	13	45	49	309	169	300	85
103+00.00	50.00	14.31	5.38	31.49	21.04	33	11	53	43	342	230	356	46
103+50.00	50.00	10.04	2.51	45.16	12.85	23	7	71	31	365	312	397	-20
104+00.00	50.00	12.77	0.00	49.86	4.29	21	2	88	16	386	413	417	-102
104+22.33	22.33	16.36	0.00	40.44	8.31	12	0	37	5	398	455	424	-132
105+75.24	0.00	45.20	3.18	11.15	23.83	0	0	0	0	398	455	424	-132
106+00.00	24.76	64.27	4.47	2.58	28.34	50	4	6	24	448	462	455	-93
106+50.00	50.00	118.91	2.70	0.00	43.06	170	7	2	66	618	465	541	67
107+00.00	50.00	79.95	0.39	0.00	30.04	184	3	0	68	802	465	629	248
107+50.00	50.00	63.72	0.00	0.00	30.74	133	0	0	56	935	465	702	381
108+00.00	50.00	52.25	0.04	0.00	26.67	107	0	0	53	1,042	465	771	488
108+50.00	50.00	52.93	2.19	0.00	26.67	97	2	0	49	1,139	465	835	583
109+00.00	50.00	39.83	4.29	0.00	25.98	86	6	0	49	1,225	465	898	663
109+50.00	50.00	24.96	5.54	0.00	21.63	60	9	0	44	1,285	465	956	714
109+74.29	24.29	21.81	0.00	0.00	18.42	21	2	0	18	1,306	465	979	733

NOTES:

- 1 - CUT INCLUDES SALVAGED/UNUSABLE PAVEMENT MATERIAL
- 2 - SALVAGED/UNUSABLE PAVEMENT MATERIAL, THIS DOES NOT SHOW UP IN CROSS SECTIONS
- 3 - FILL, DOES NOT INCLUDE UNUSABLE PAVEMENT EXC VOLUME
- 5 - EXPANDED EBS, WILL BE BACKFILLED WITH SELECT CRUSHED MATERIAL
- 6 - MASS ORDINATE DOES NOT ACCOUNT FOR EBS

ALIGNMENT - ALI-CTHU-7MILRD-CENTER

STATION	DISTANCE	AREA (SF)				INCREMENTAL VOL (CY) (UNADJUSTED)				CUMULATIVE VOL (CY)			
		CUT	SALVAGED/UNUSABLE PAVEMENT MATERIAL	FILL	EBS	CUT	SALVAGED/UNUSABLE PAVEMENT MATERIAL	FILL	EBS	CUT	EXPANDED FILL	EXPANDED EBS BACKFILL	MASS ORDINATE
1+00.00	0.00	19.34	19.92	104.84	26.79	0	0	0	0	0	0	0	0
1+25.00	25.00	91.79	24.20	104.84	56.14	51	20	97	38	51	112	49	-81
1+50.00	25.00	22.71	32.75	86.45	47.99	53	26	89	48	104	214	112	-156
1+75.00	25.00	54.94	20.33	126.29	35.02	36	25	98	38	140	327	161	-258
2+00.00	25.00	141.09	24.85	108.97	55.17	91	21	109	42	231	452	216	-313
2+25.00	25.00	24.52	32.77	91.87	48.46	77	27	93	48	308	559	278	-370
2+50.00	25.00	15.24	22.16	123.74	47.60	18	25	100	44	326	674	335	-492
2+74.97	24.97	32.73	32.75	88.13	48.50	22	25	98	44	348	787	393	-608
3+00.00	25.03	42.67	23.77	86.13	48.48	35	26	81	45	383	880	451	-692
3+25.00	25.00	23.69	18.34	163.37	21.57	31	19	116	32	414	1,013	493	-813
3+50.00	25.00	18.33	32.73	86.51	47.87	19	24	116	32	433	1,147	534	-952
1+00.00	36.00	19.34	19.92	104.84	26.79	25	35	128	50	458	1,294	599	-1,109

NOTES:

- 1 - CUT INCLUDES SALVAGED/UNUSABLE PAVEMENT MATERIAL
- 2 - SALVAGED/UNUSABLE PAVEMENT MATERIAL, THIS DOES NOT SHOW UP IN CROSS SECTIONS
- 3 - FILL, DOES NOT INCLUDE UNUSABLE PAVEMENT EXC VOLUME
- 5 - EXPANDED EBS, WILL BE BACKFILLED WITH SELECT CRUSHED MATERIAL
- 6 - MASS ORDINATE DOES NOT ACCOUNT FOR EBS

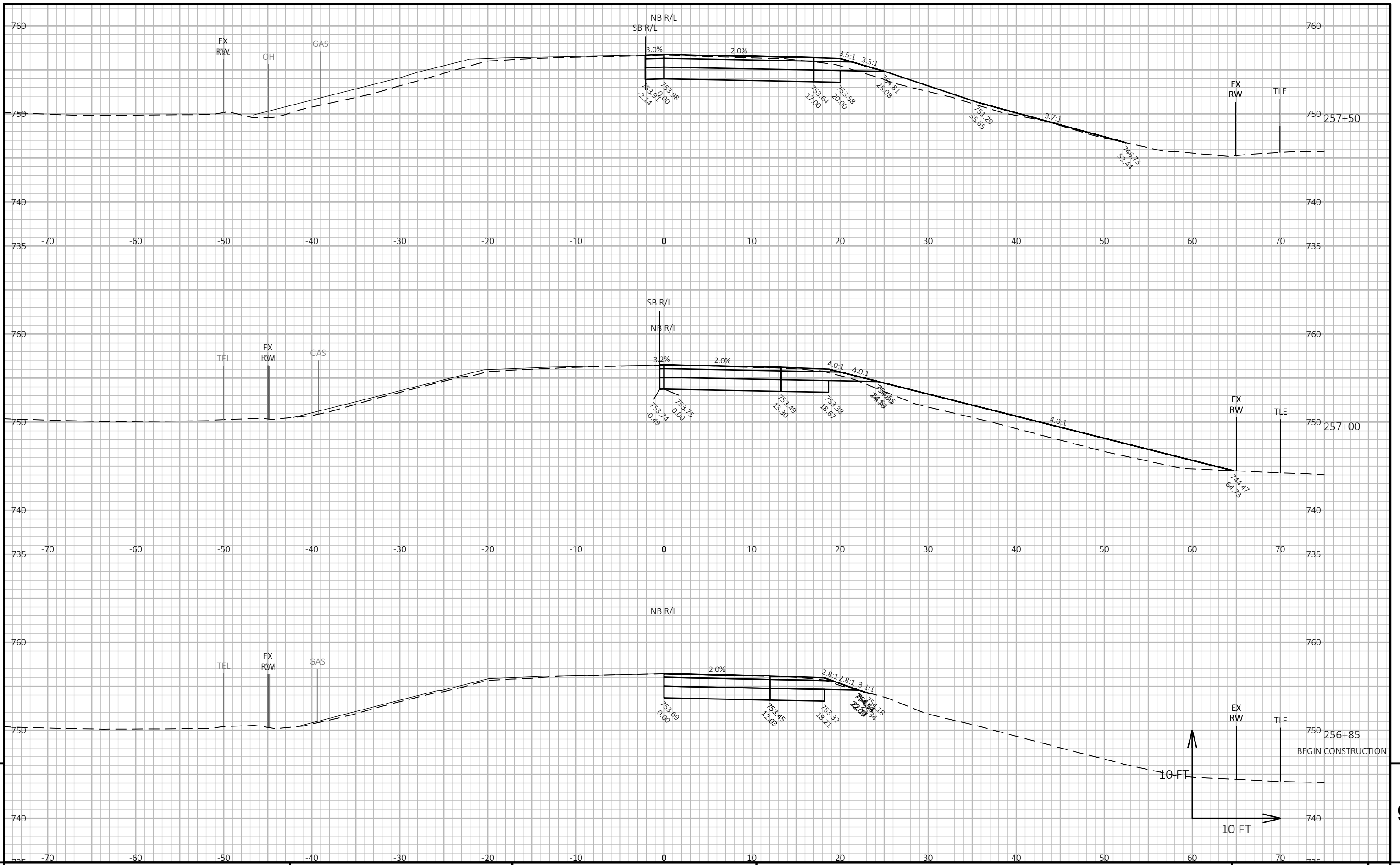

9

9

PROJECT NO: 2816-03-70      HWY: CTH U      COUNTY: RACINE      CROSS SECTIONS: CROSS SECTIONS - CTH U NB      SHEET      E

FILE NAME : Y:\54XX\5487.DP22.CTH.U.RCN.INTR.7.MILE.RD\CADD\28160300\SHEETS\090201-XS NEW.DWG      PLOT DATE : 10/23/2023 12:12 PM      PLOT BY : KATIE NAKLES      PLOT NAME :      PLOT SCALE : 1 IN:10 FT HORZ. / 1 IN:10 FT VERT.      WISDOT/CADD SHEET 49

LAYOUT NAME - NB1

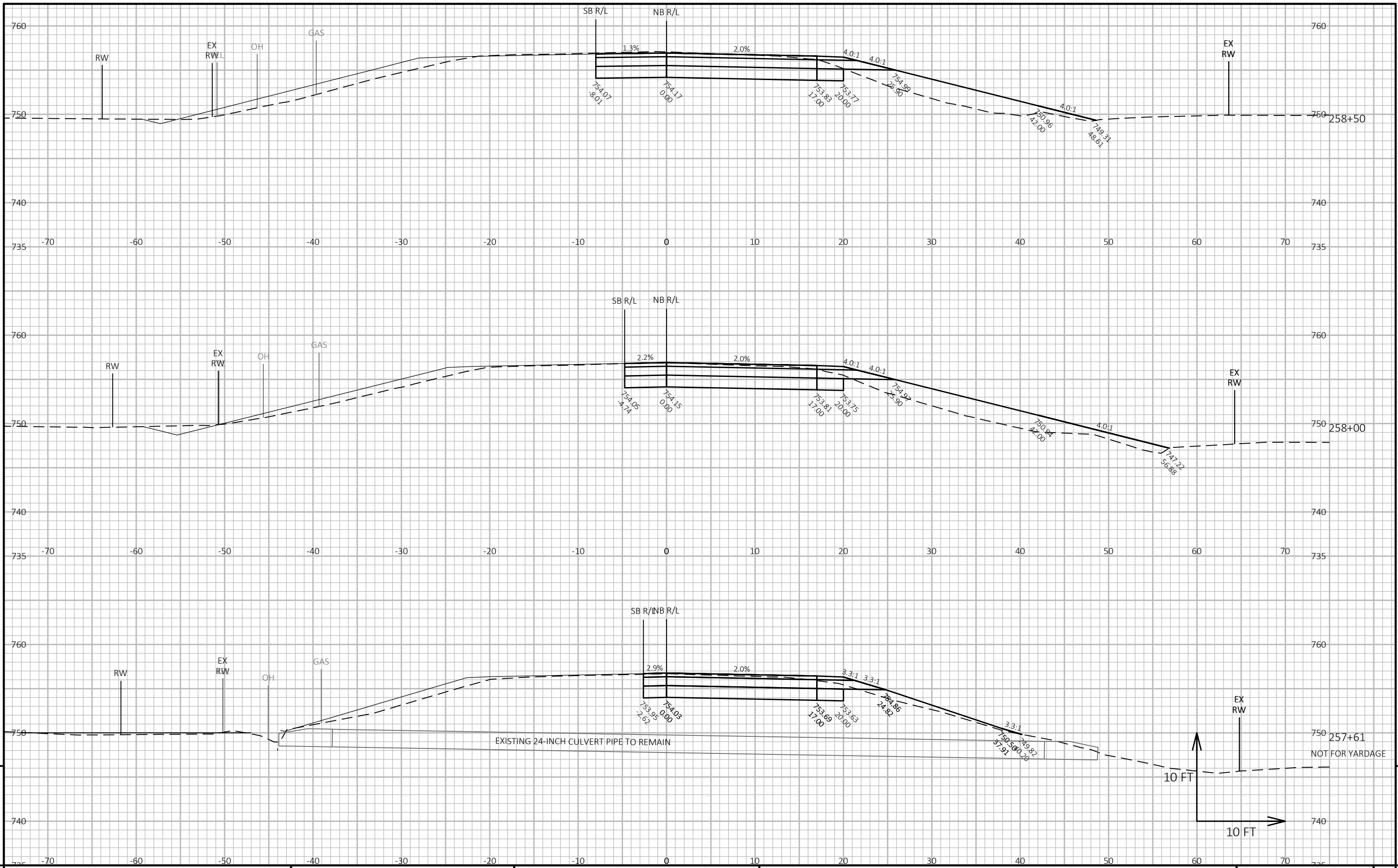

PROJECT NO: 2816-03-70 HWY: CTH U COUNTY: RACINE CROSS SECTIONS: CROSS SECTIONS - CTH U NB SHEET 9

FILE NAME: Y:\54XX\5487.DP22.CTH.U.RCN.INTR.7.MILE.RD\CADD\28160300\SHEETS\090201-XS NEW.DWG PLOT DATE: 10/23/2023 12:12 PM PLOT BY: KATIE NAKLES PLOT NAME: LAYOUT NAME - NB2 PLOT SCALE: 1 IN:10 FT HORZ. / 1 IN:10 FT VERT. WISDOT/CADD SHEET 49

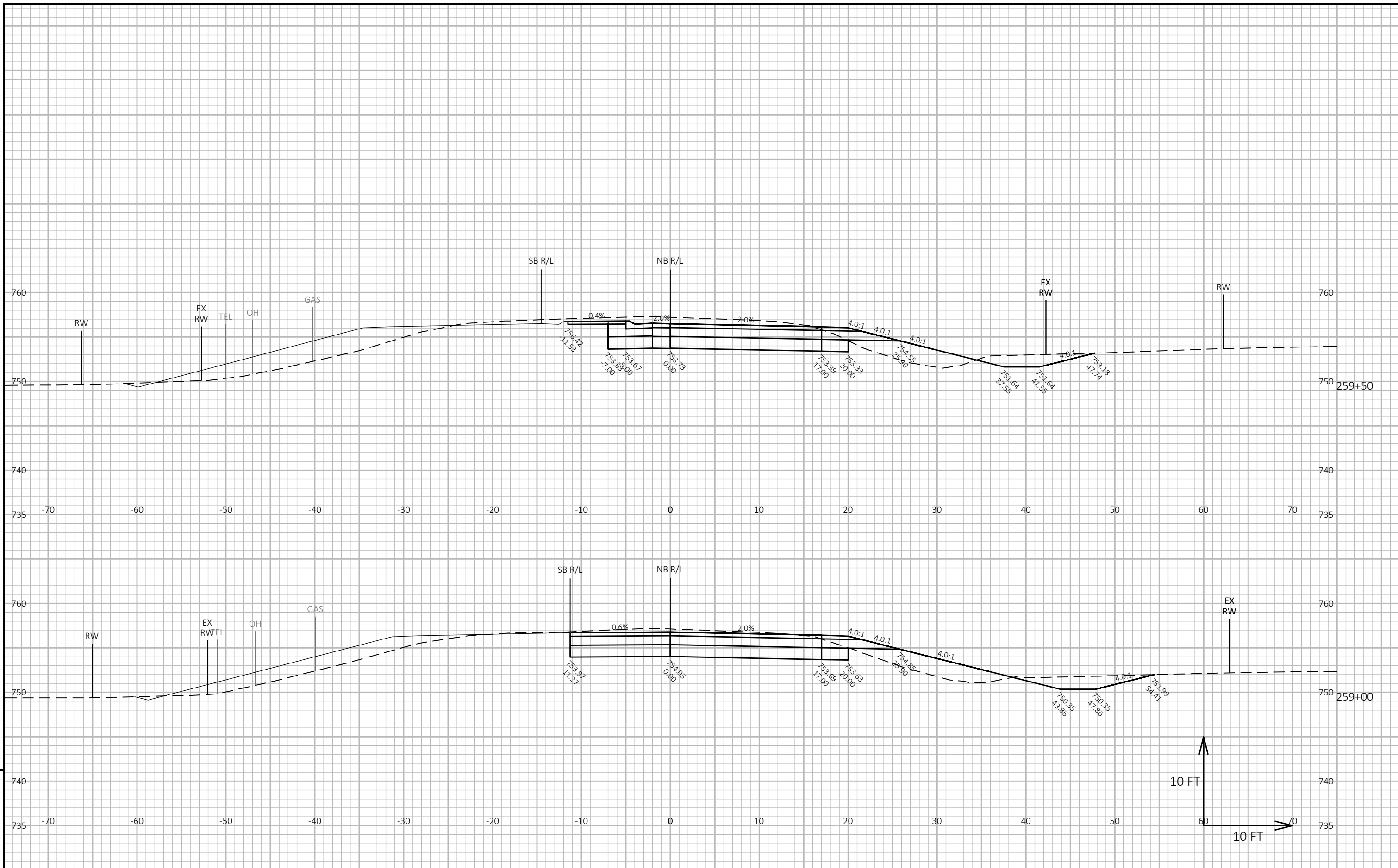

PROJECT NO: 2816-03-70

HWY: CTH U

COUNTY: RACINE

CROSS SECTIONS: CROSS SECTIONS - CTH U NB

SHEET

E





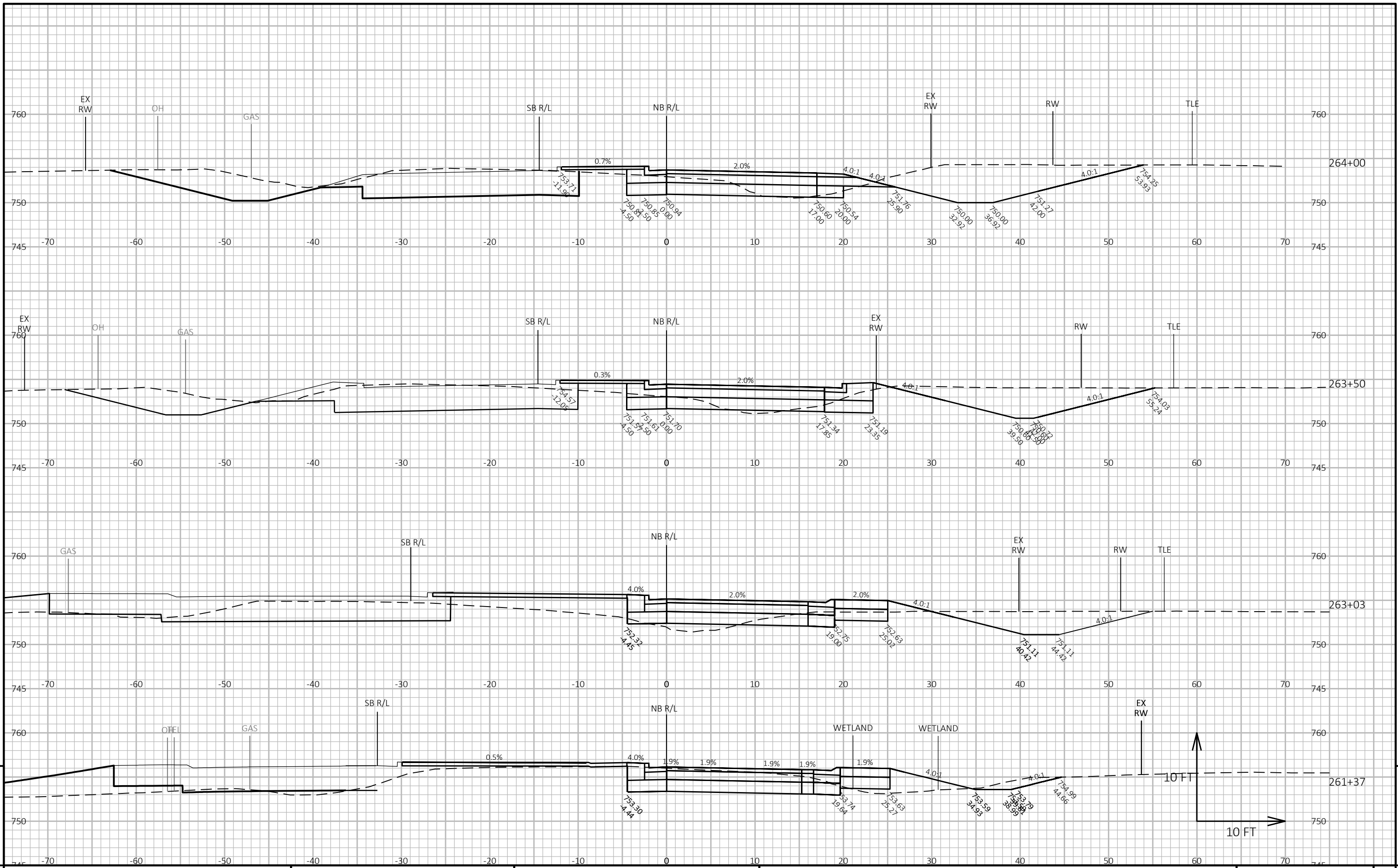

9

9

PROJECT NO: 2816-03-70      HWY: CTH U      COUNTY: RACINE      CROSS SECTIONS: CROSS SECTIONS - CTH U NB      SHEET      E

FILE NAME : Y:\54XX\5487.DP22.CTH.U.RCN.INTR.7.MILE.RD\CADD\28160300\SHEETS\090201-XS NEW.DWG      PLOT DATE : 10/23/2023 12:12 PM      PLOT BY : KATIE NAKLES      PLOT NAME :      PLOT SCALE : 1 IN:10 FT HORZ. / 1 IN:10 FT VERT.      WISDOT/CADD SHEET 49

LAYOUT NAME - NBS

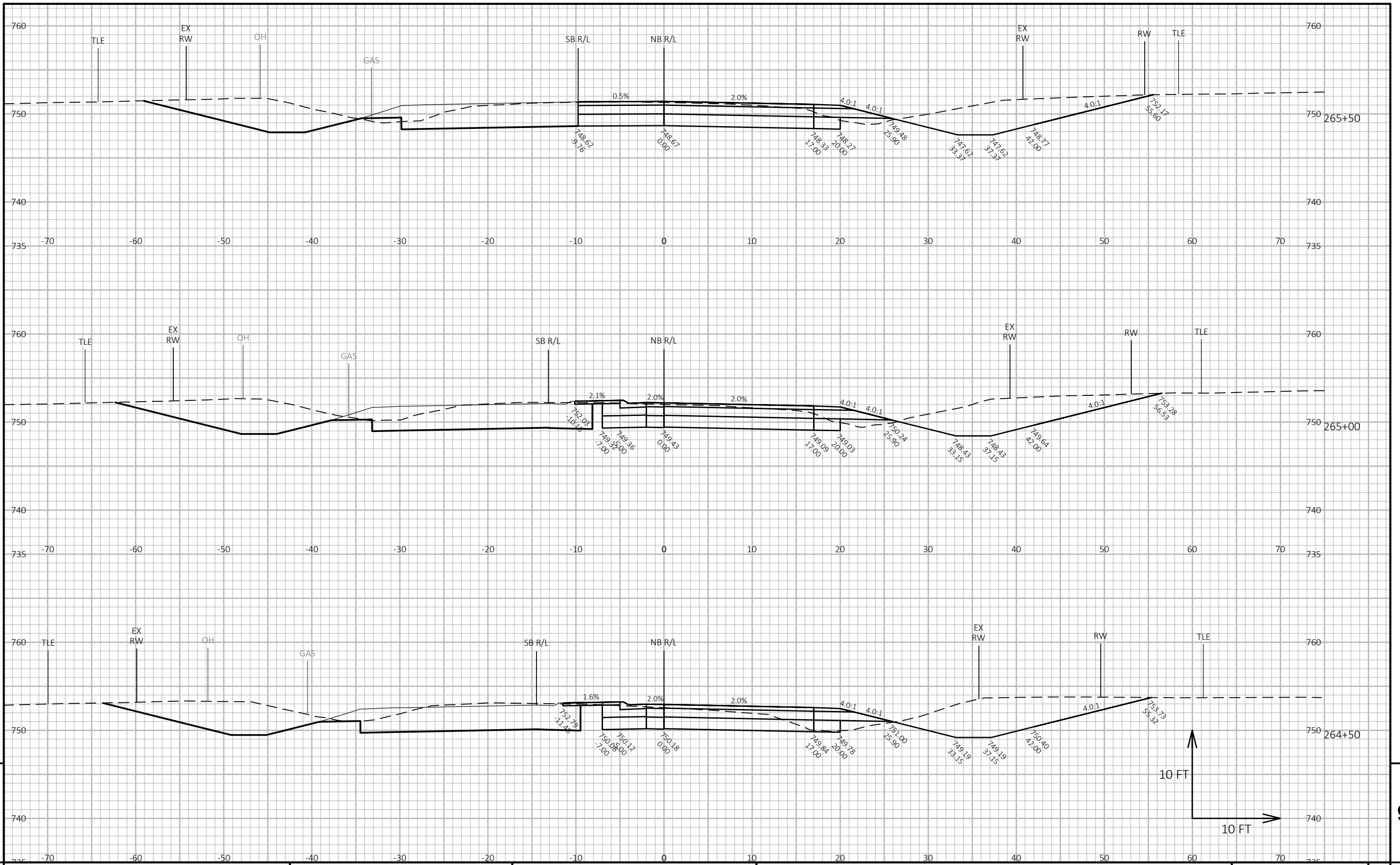

9
10 FT
10 FT
9

PROJECT NO: 2816-03-70      HWY: CTH U      COUNTY: RACINE      CROSS SECTIONS: CROSS SECTIONS - CTH U NB      SHEET E

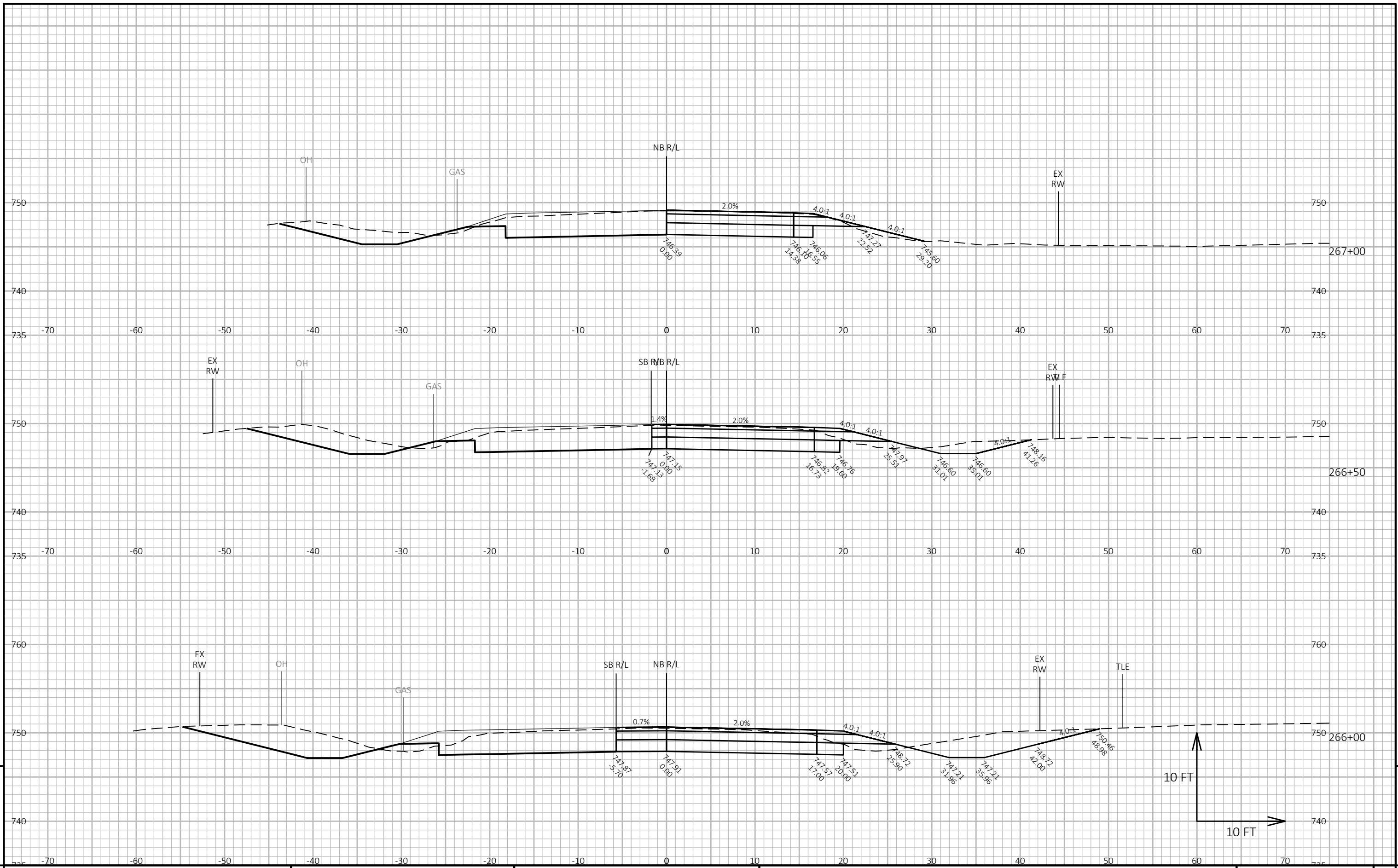

9

9

PROJECT NO: 2816-03-70      HWY: CTH U      COUNTY: RACINE      CROSS SECTIONS: CROSS SECTIONS - CTH U NB      SHEET      E

FILE NAME : Y:\54XX\5487.DP22.CTH.U.RCN.INTR.7.MILE.RD\CADD\28160300\SHEETS\090201-XS NEW.DWG      PLOT DATE : 10/23/2023 12:13 PM      PLOT BY : KATIE NAKLES      PLOT NAME :      PLOT SCALE : 1 IN:10 FT HORZ. / 1 IN:10 FT VERT.      WISDOT/CADD SHEET 49

LAYOUT NAME - NB7

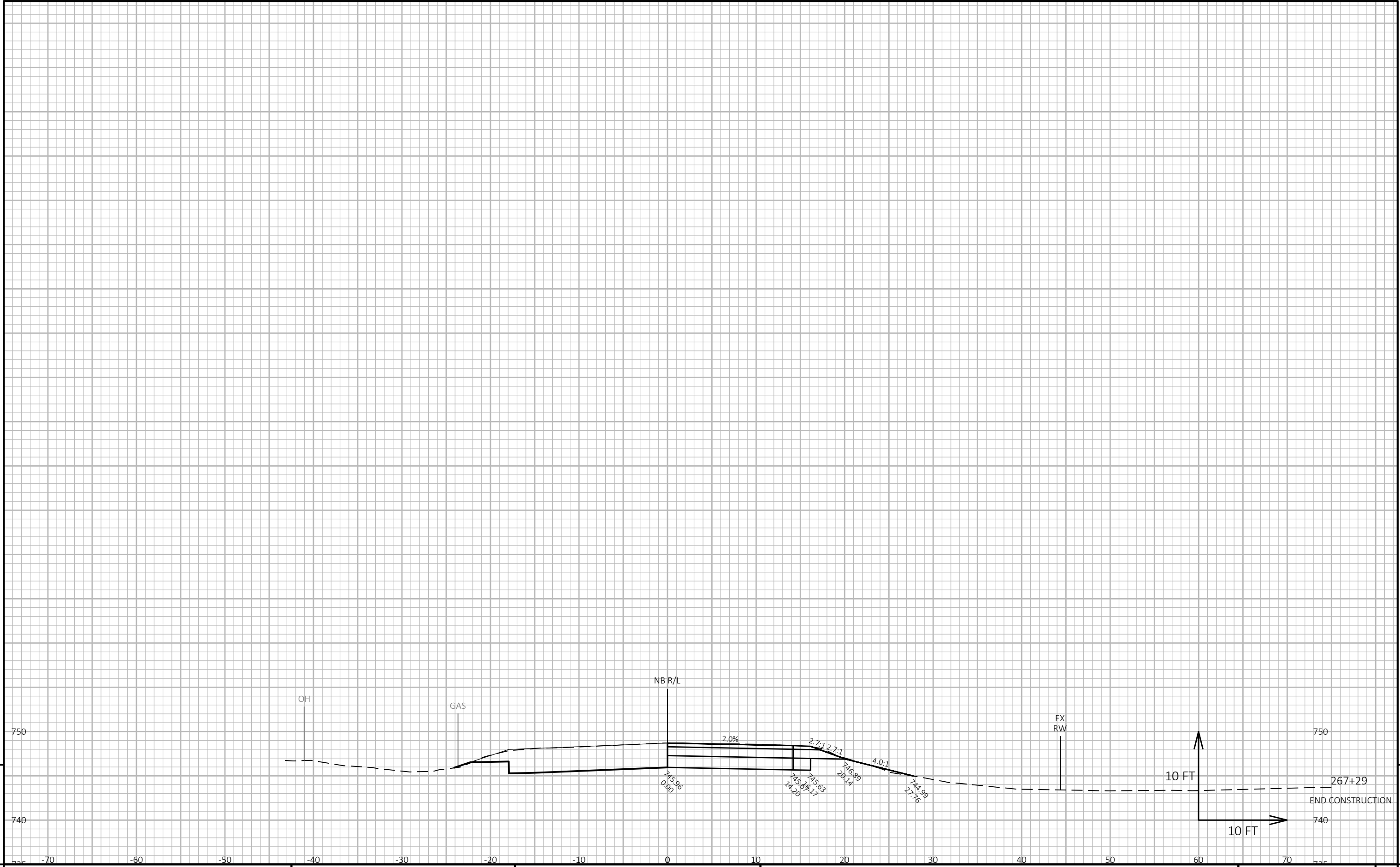

9

9

PROJECT NO: 2816-03-70	HWY: CTH U	COUNTY: RACINE	CROSS SECTIONS: CROSS SECTIONS - CTH U NB	SHEET	E
------------------------	------------	----------------	---	-------	---

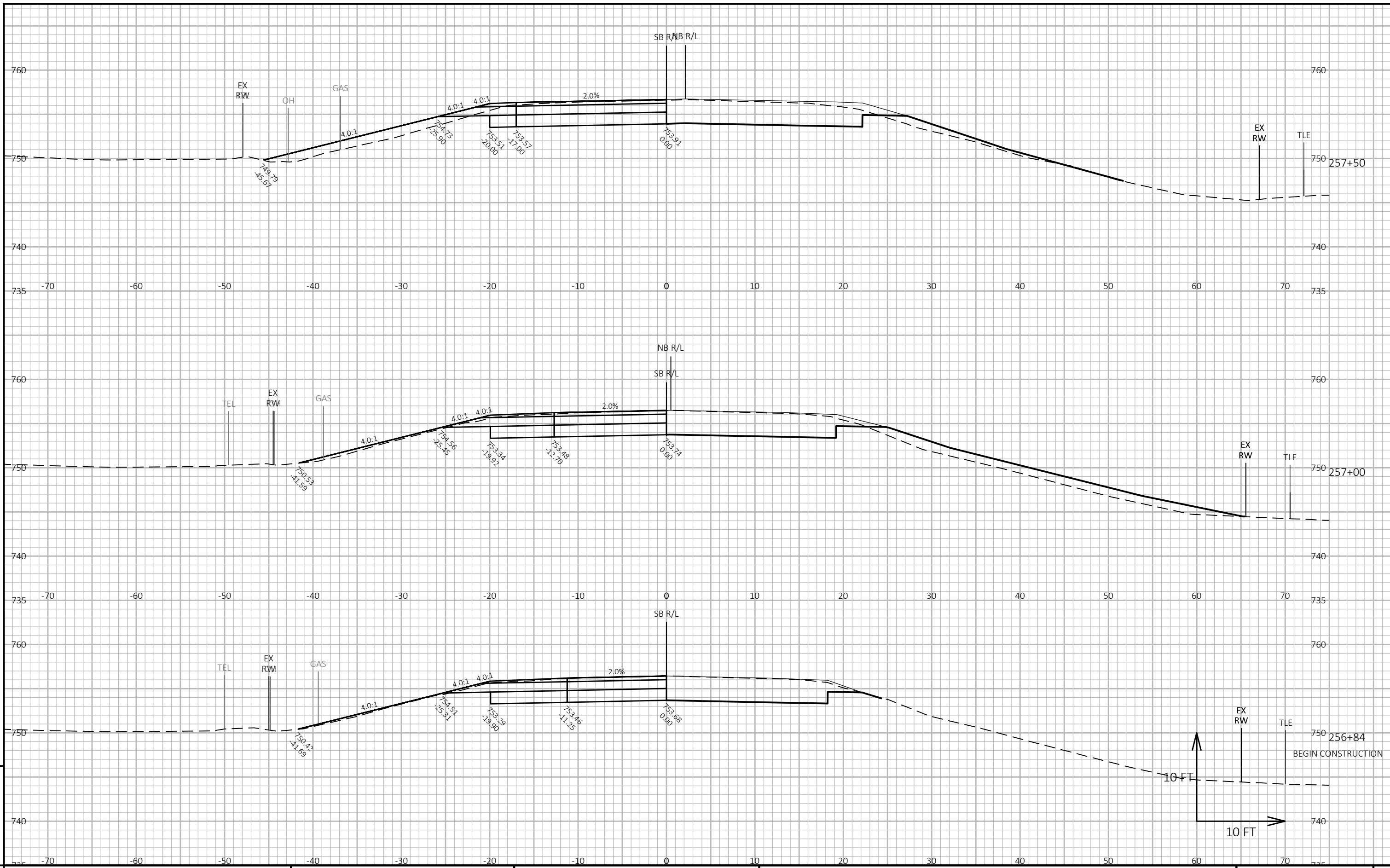

9

9

PROJECT NO: 2816-03-70      HWY: CTH U      COUNTY: RACINE      CROSS SECTIONS: CROSS SECTIONS - CTH U SB      SHEET      E

FILE NAME : Y:\54XX\5487.DP22.CTH.U.RCN.INTR.7.MILE.RD\CADD\28160300\SHEETS\090201-XS NEW.DWG      PLOT DATE : 10/23/2023 12:13 PM      PLOT BY : KATIE NAKLES      PLOT NAME :      PLOT SCALE : 1 IN:10 FT HORZ. / 1 IN:10 FT VERT.      WISDOT/CADD SHEET 49

LAYOUT NAME - SB1

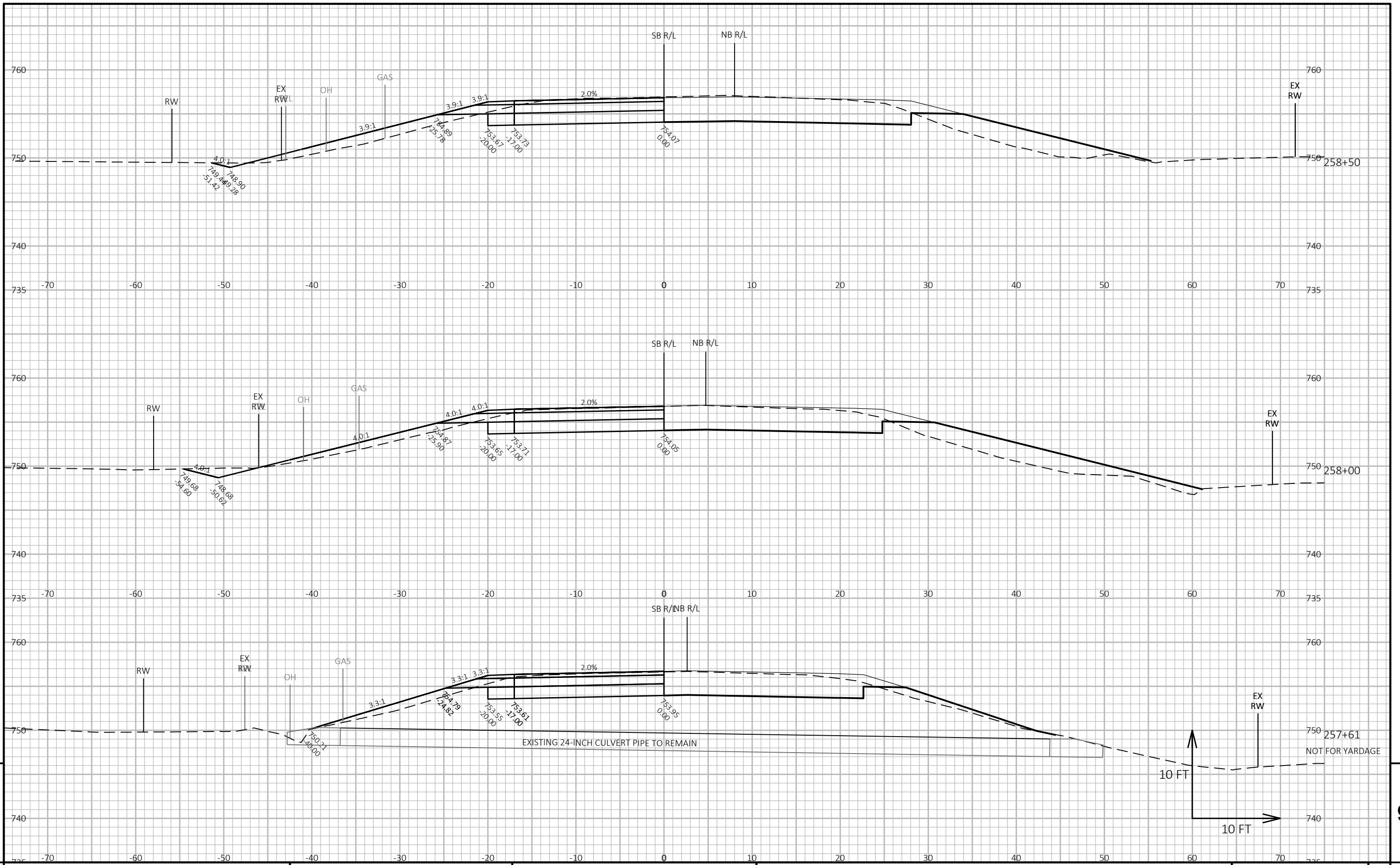

9

9

PROJECT NO: 2816-03-70	HWY: CTH U	COUNTY: RACINE	CROSS SECTIONS: CROSS SECTIONS - CTH U SB	SHEET	E
------------------------	------------	----------------	---	-------	---

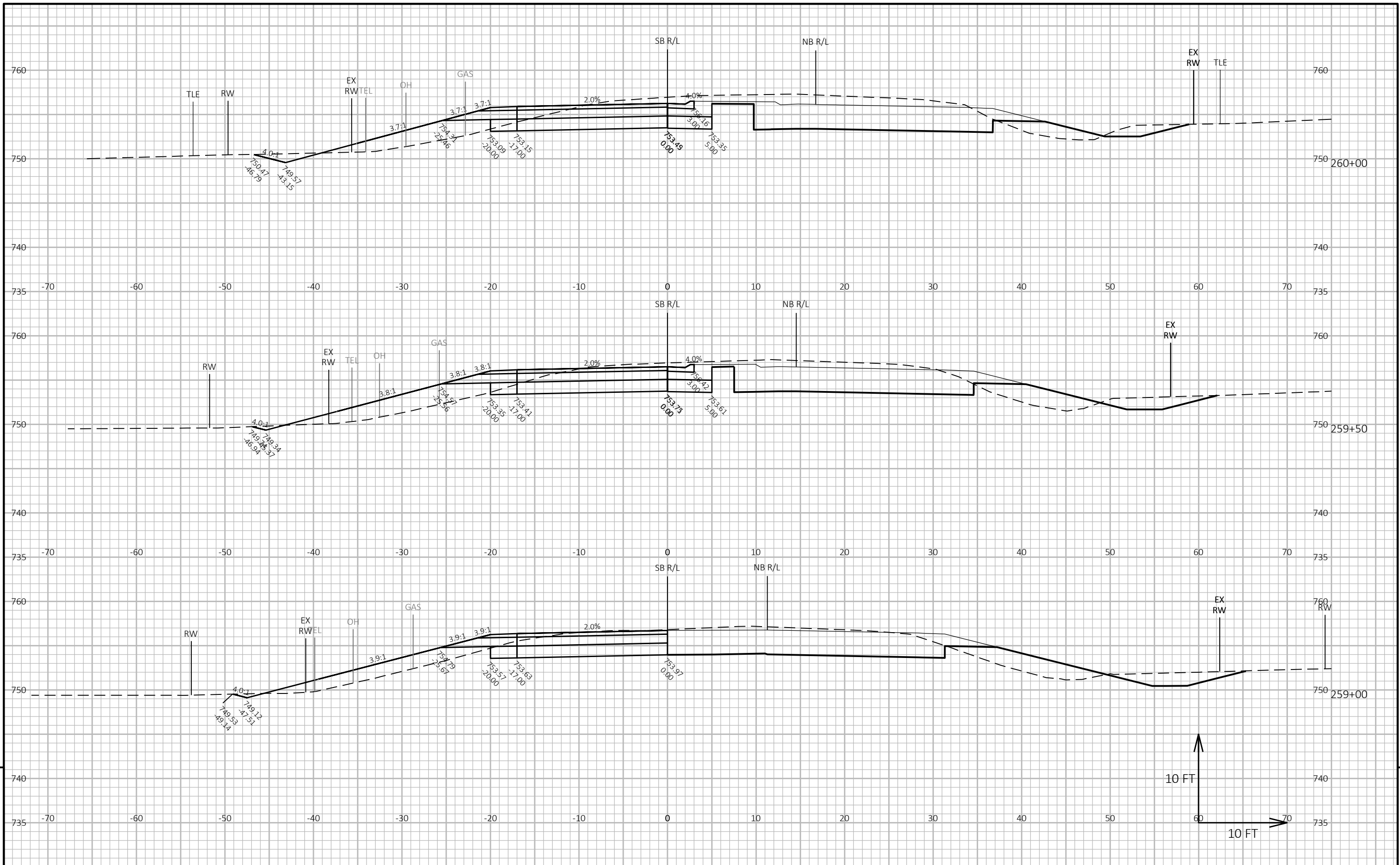

PROJECT NO: 2816-03-70	HWY: CTH U	COUNTY: RACINE	CROSS SECTIONS: CROSS SECTIONS - CTH U SB	SHEET	<b>E</b>
------------------------	------------	----------------	---	-------	----------

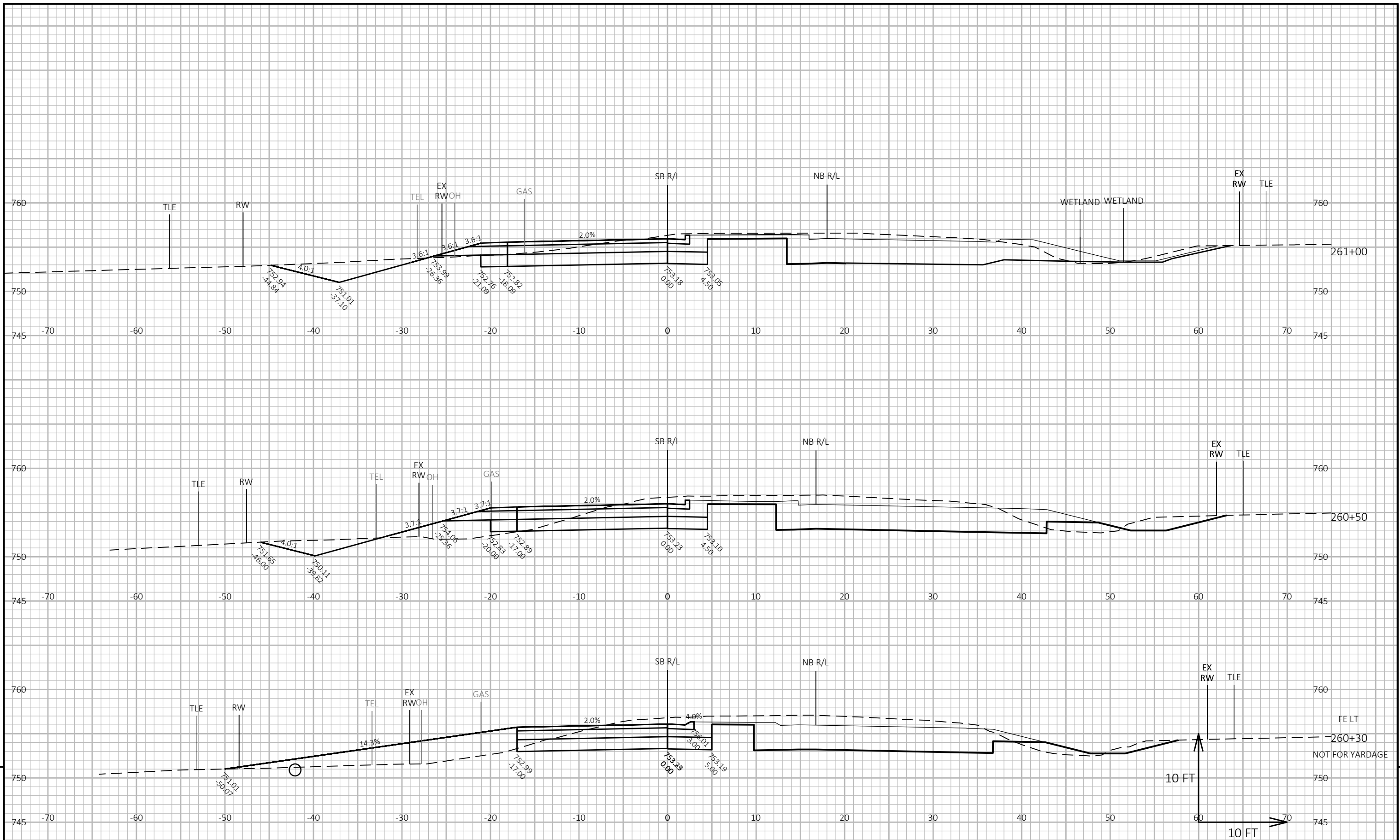

PROJECT NO: 2816-03-70      HWY: CTH U      COUNTY: RACINE      CROSS SECTIONS: CROSS SECTIONS - CTH U SB      SHEET 9



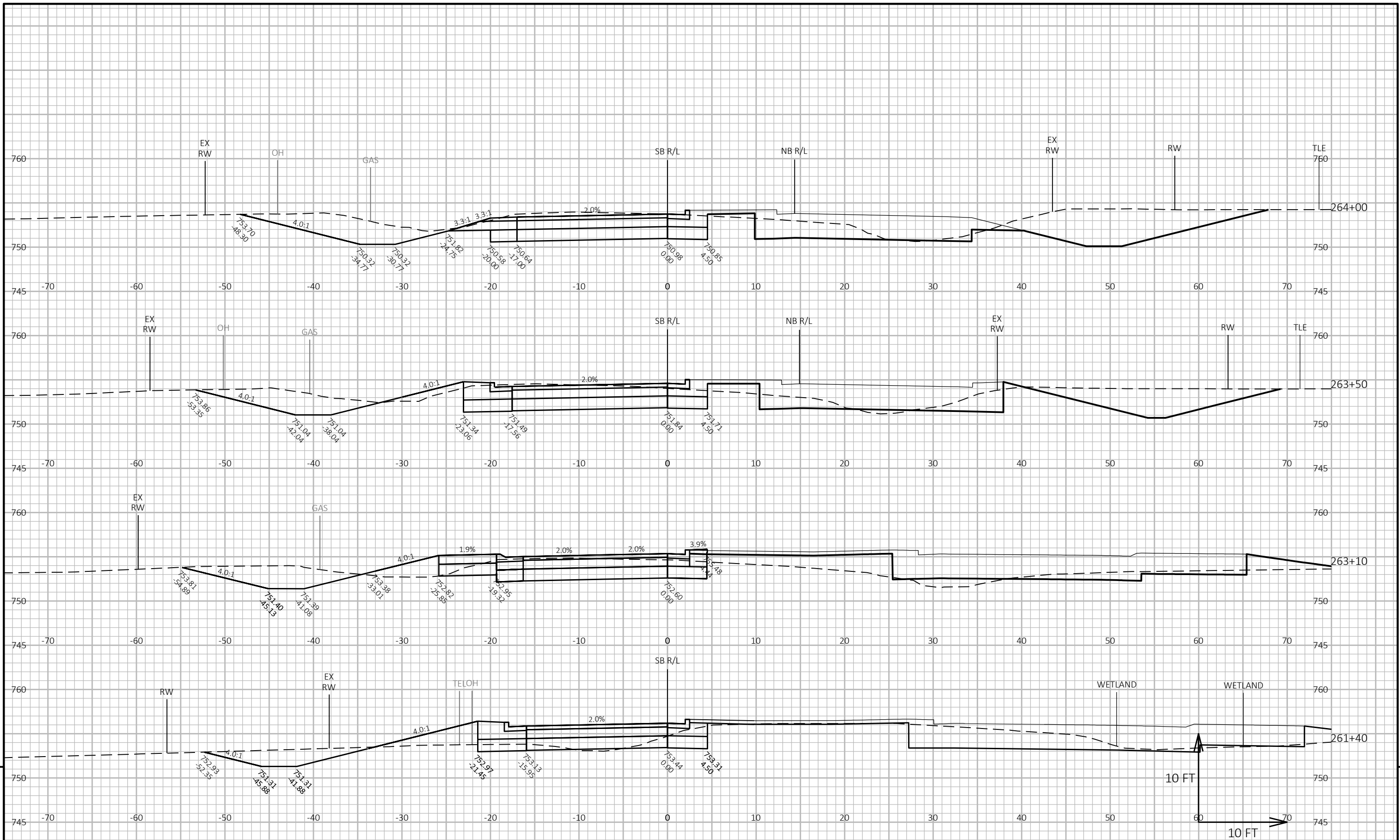

9

9

PROJECT NO: 2816-03-70	HWY: CTH U	COUNTY: RACINE	CROSS SECTIONS: CROSS SECTIONS - CTH U SB	SHEET E
------------------------	------------	----------------	---	---------

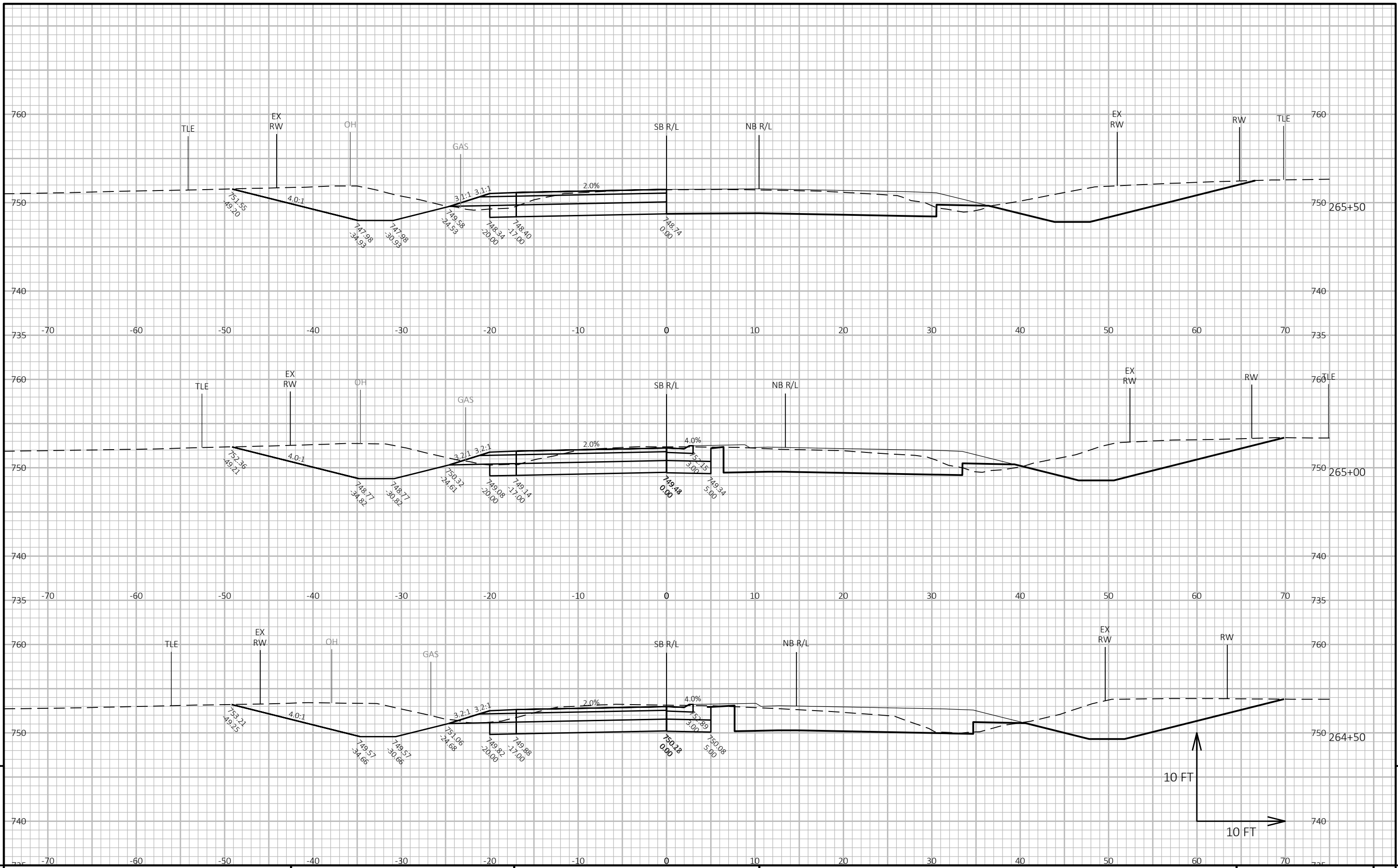

9

9

PROJECT NO: 2816-03-70      HWY: CTH U      COUNTY: RACINE      CROSS SECTIONS: CROSS SECTIONS - CTH U SB      SHEET      E

FILE NAME : Y:\54XX\5487.DP22.CTH.U.RCN.INTR.7.MILE.RD\CADD\28160300\SHEETS\090201-XS NEW.DWG      PLOT DATE : 10/23/2023 12:13 PM      PLOT BY : KATIE NAKLES      PLOT NAME :      PLOT SCALE : 1 IN:10 FT HORZ. / 1 IN:10 FT VERT.      WISDOT/CADD SHEET 49

LAYOUT NAME - SB6



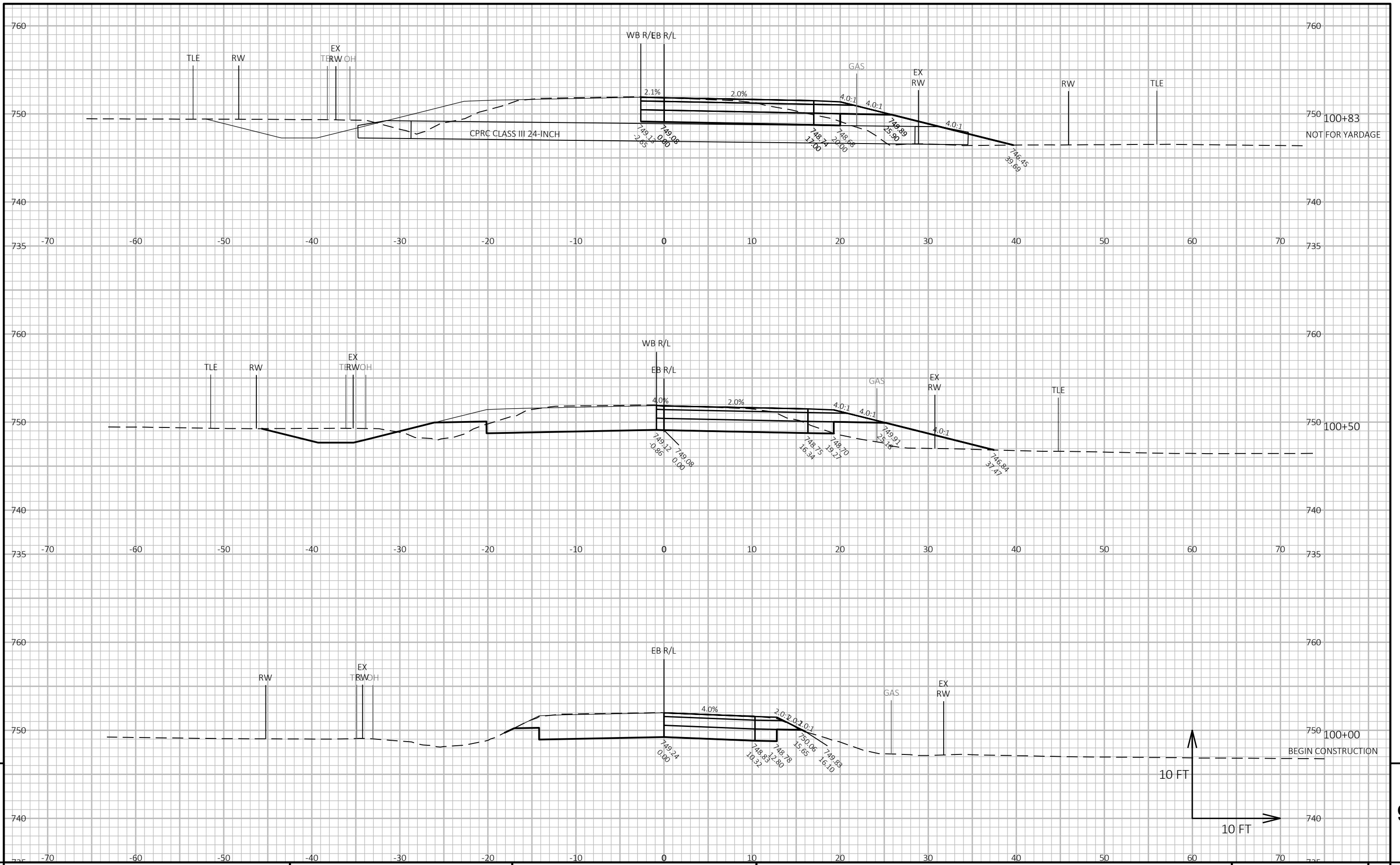

PROJECT NO: 2816-03-70      HWY: CTH U      COUNTY: RACINE      CROSS SECTIONS: CROSS SECTIONS - 7 MILE RD EB      SHEET 9

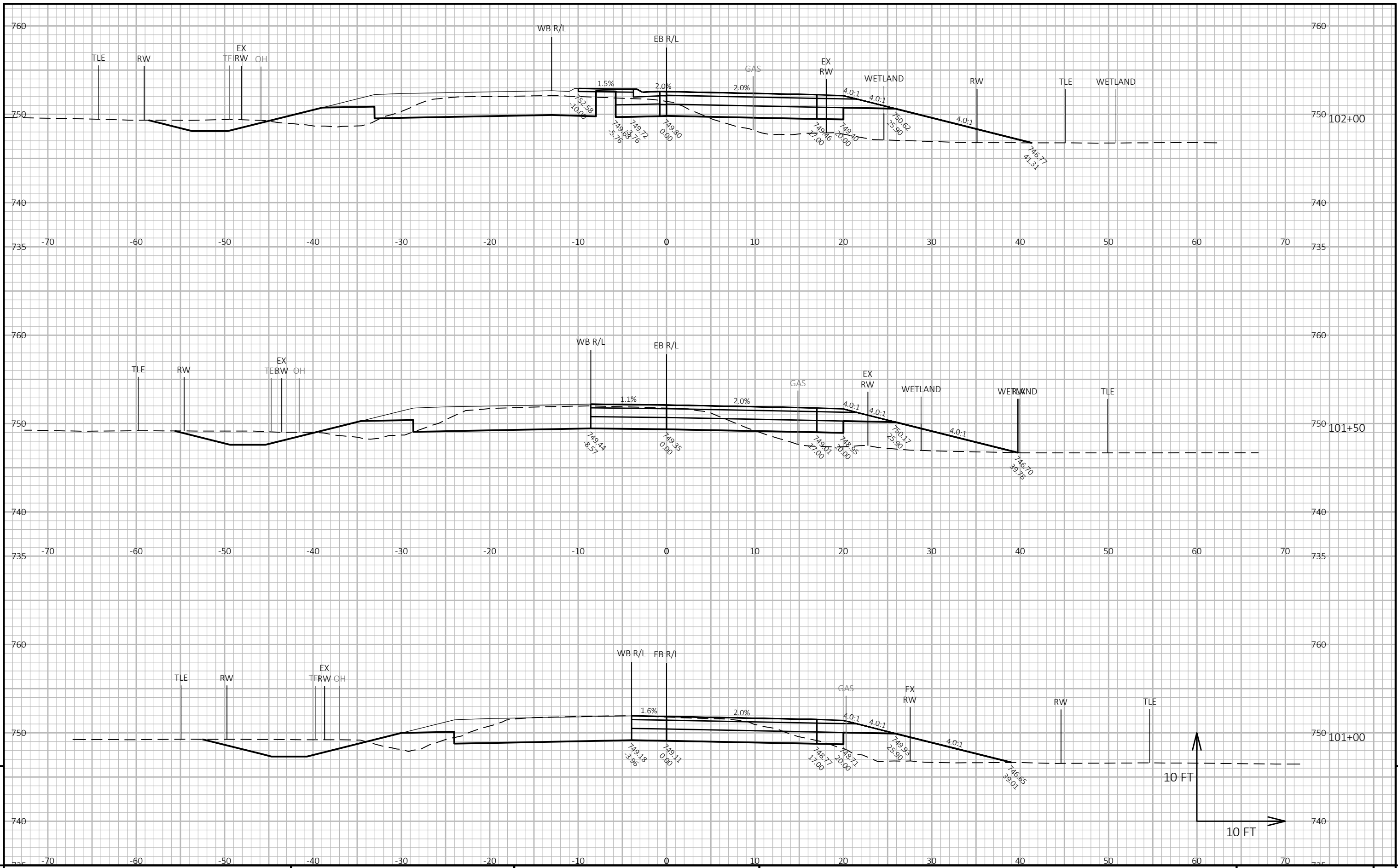

PROJECT NO: 2816-03-70      HWY: CTH U      COUNTY: RACINE      CROSS SECTIONS: CROSS SECTIONS - 7 MILE RD EB      SHEET      E

FILE NAME : Y:\54XX\5487.DP22.CTH.U.RCN.INTR.7.MILE.RD\CADD\28160300\SHEETS\090201-XS NEW.DWG      PLOT DATE : 10/23/2023 12:13 PM      PLOT BY : KATIE NAKLES      PLOT NAME :      PLOT SCALE : 1 IN:10 FT HORZ. / 1 IN:10 FT VERT.      WISDOT/CADD SHEET 49

LAYOUT NAME - EB2

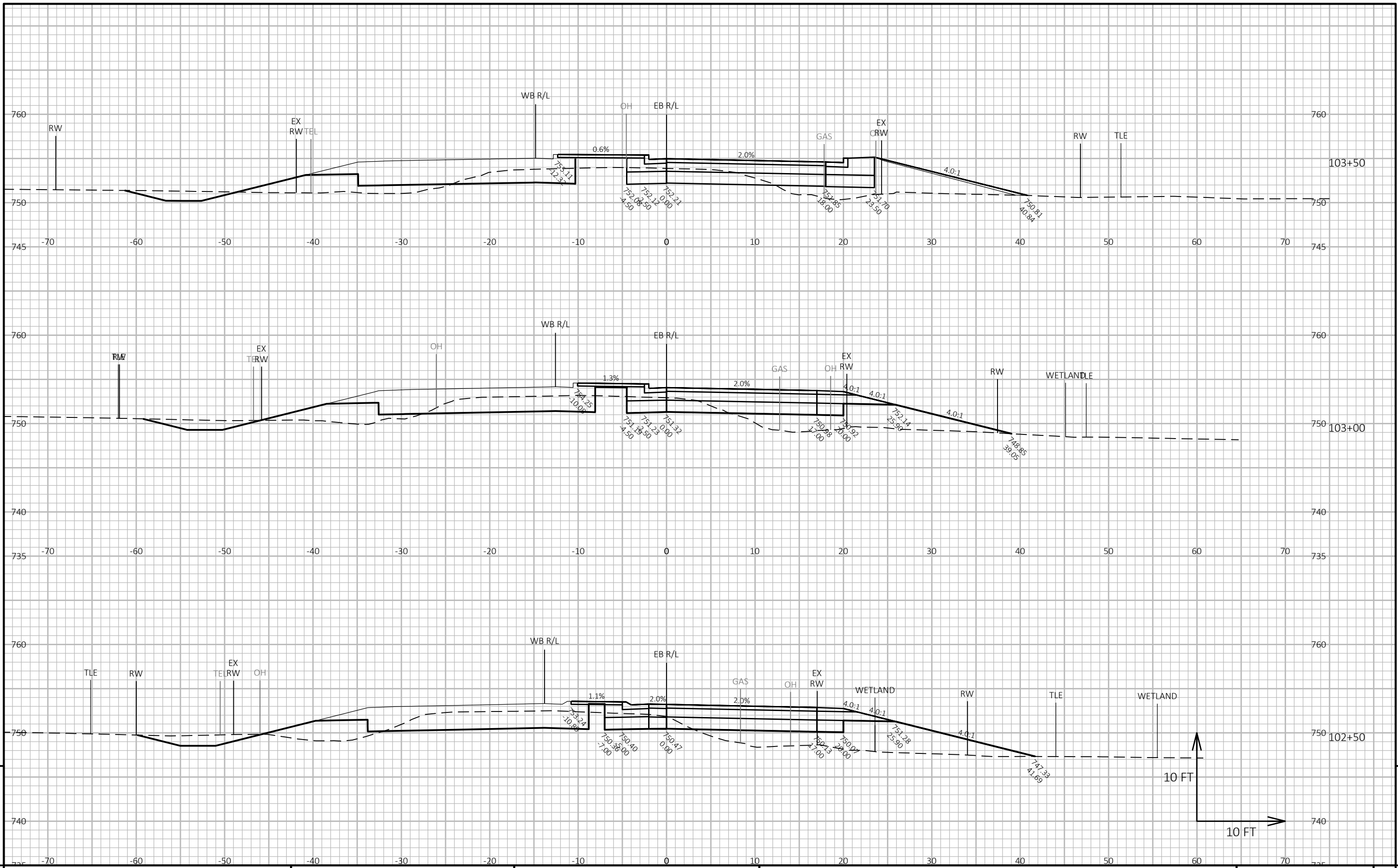



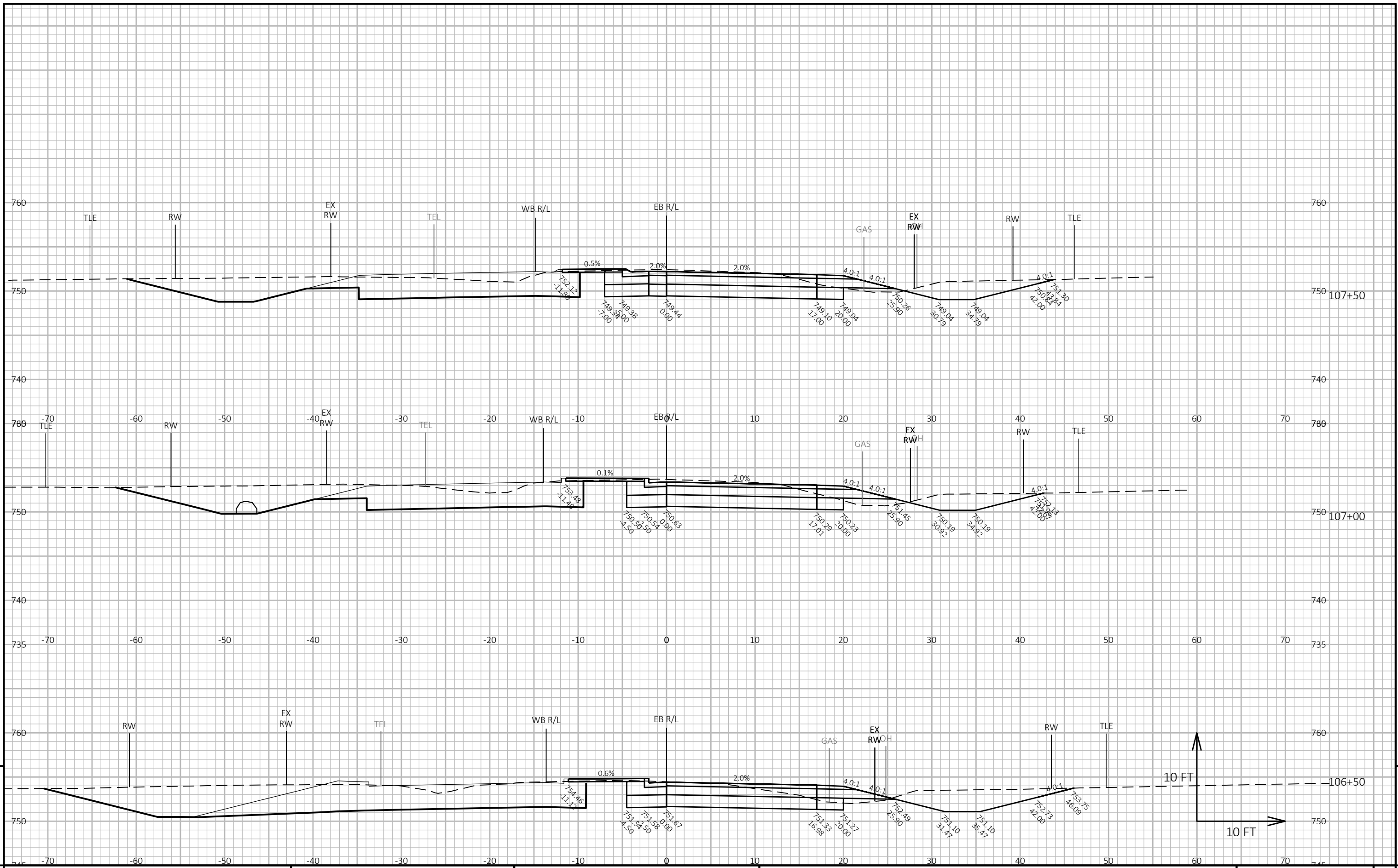

PROJECT NO: 2816-03-70      HWY: CTH U      COUNTY: RACINE      CROSS SECTIONS: CROSS SECTIONS - 7 MILE RD EB      SHEET      E



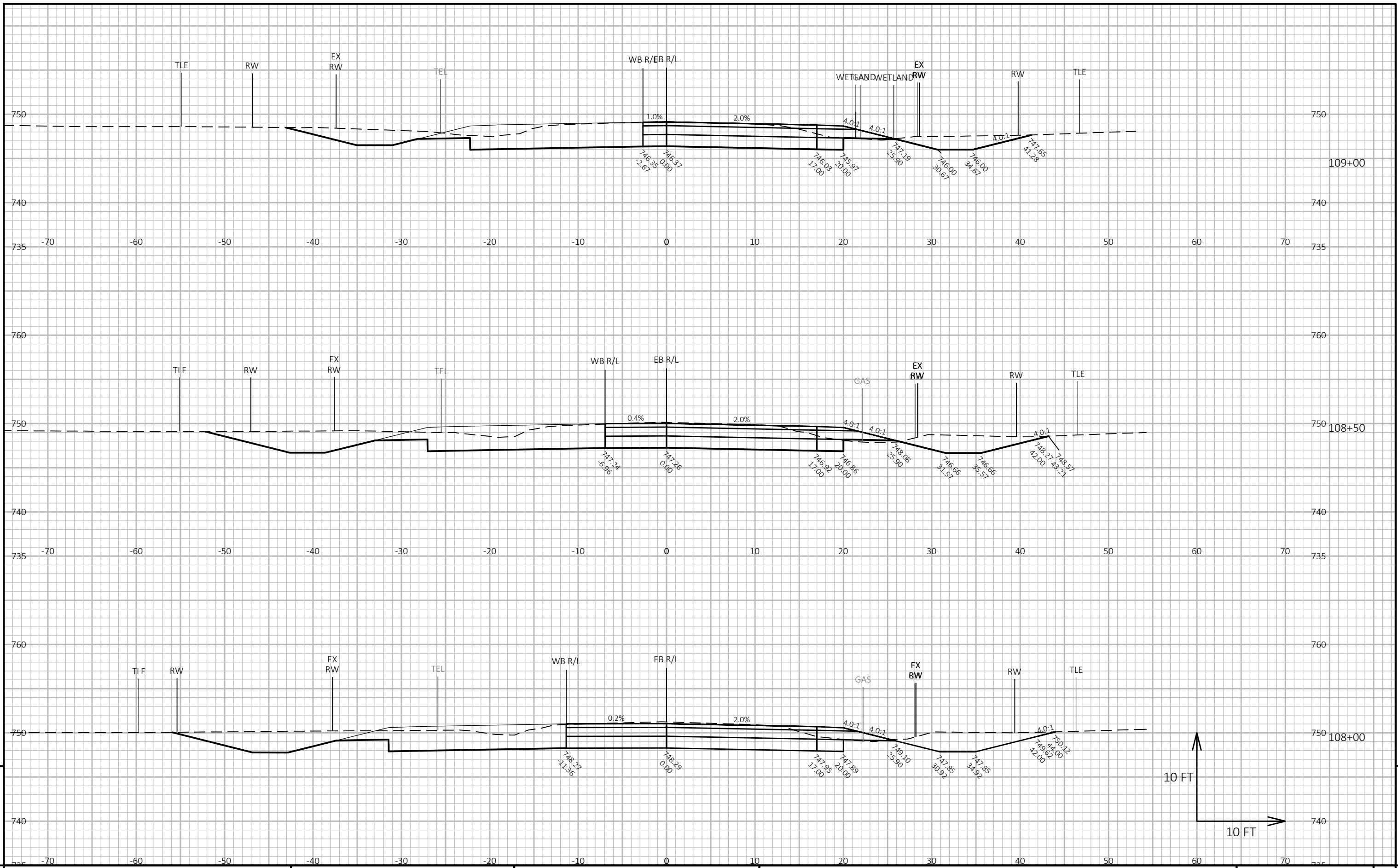

9

9

PROJECT NO: 2816-03-70      HWY: CTH U      COUNTY: RACINE      CROSS SECTIONS: CROSS SECTIONS - 7 MILE RD EB      SHEET      E

FILE NAME: Y:\54XX\5487.DP22.CTH.U.RCN.INTR.7.MILE.RD\CADD\28160300\SHEETS\090201-XS NEW.DWG      PLOT DATE: 10/23/2023 12:13 PM      PLOT BY: KATIE NAKLES      PLOT NAME:      PLOT SCALE: 1 IN:10 FT HORZ. / 1 IN:10 FT VERT.      WISDOT/CADD SHEET 49

LAYOUT NAME - EB6

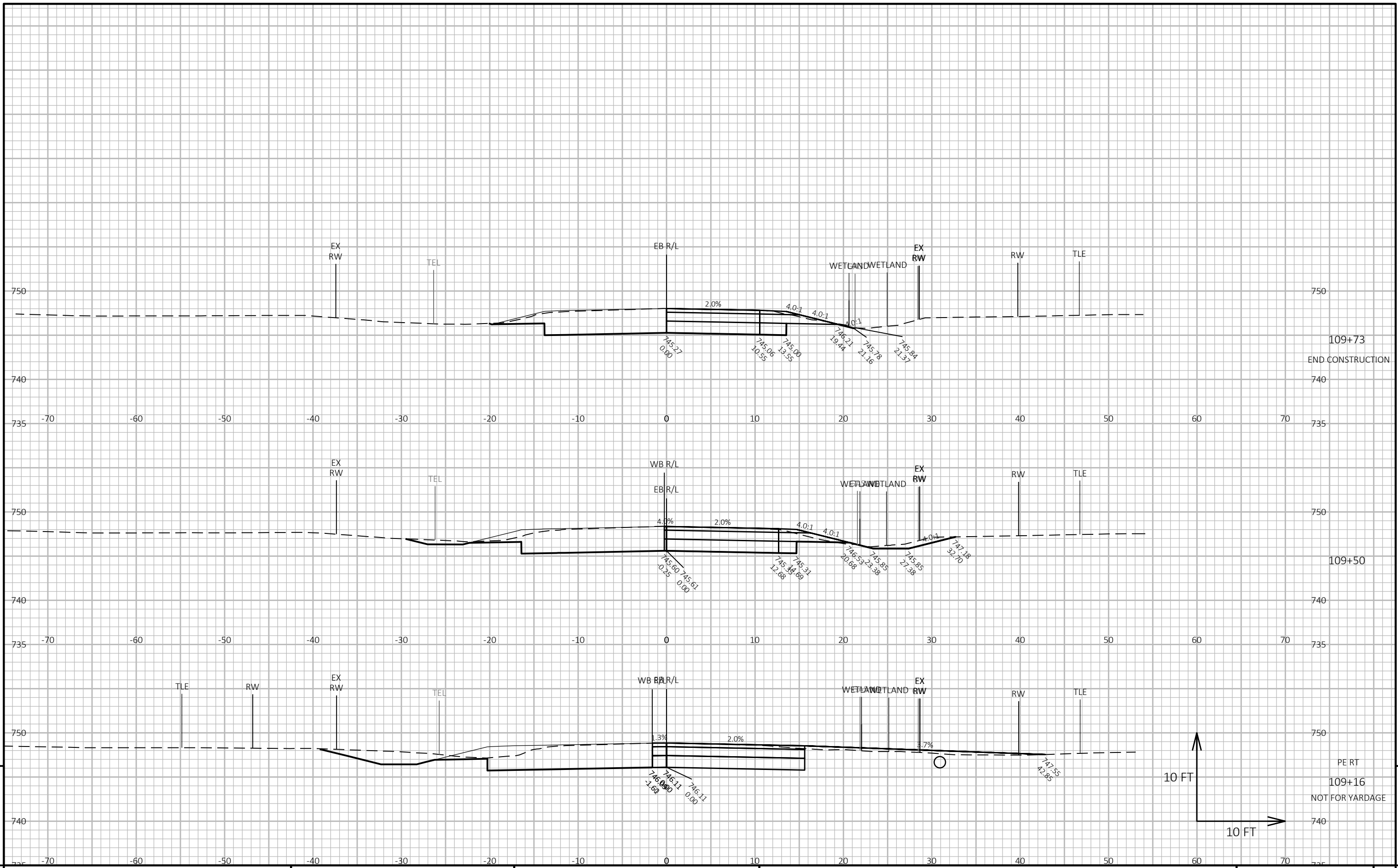

PROJECT NO: 2816-03-70      HWY: CTH U      COUNTY: RACINE      CROSS SECTIONS: CROSS SECTIONS - 7 MILE RD EB      SHEET: 9

FILE NAME: Y:\54XX\5487.DP22.CTH.U.RCN.INTR.7.MILE.RD\CADD\28160300\SHEETS\090201-XS NEW.DWG      PLOT DATE: 10/23/2023 12:13 PM      PLOT BY: KATIE NAKLES      PLOT NAME:      PLOT SCALE: 1 IN:10 FT HORZ. / 1 IN:10 FT VERT.      WISDOT/CADD SHEET 49

LAYOUT NAME - EB7



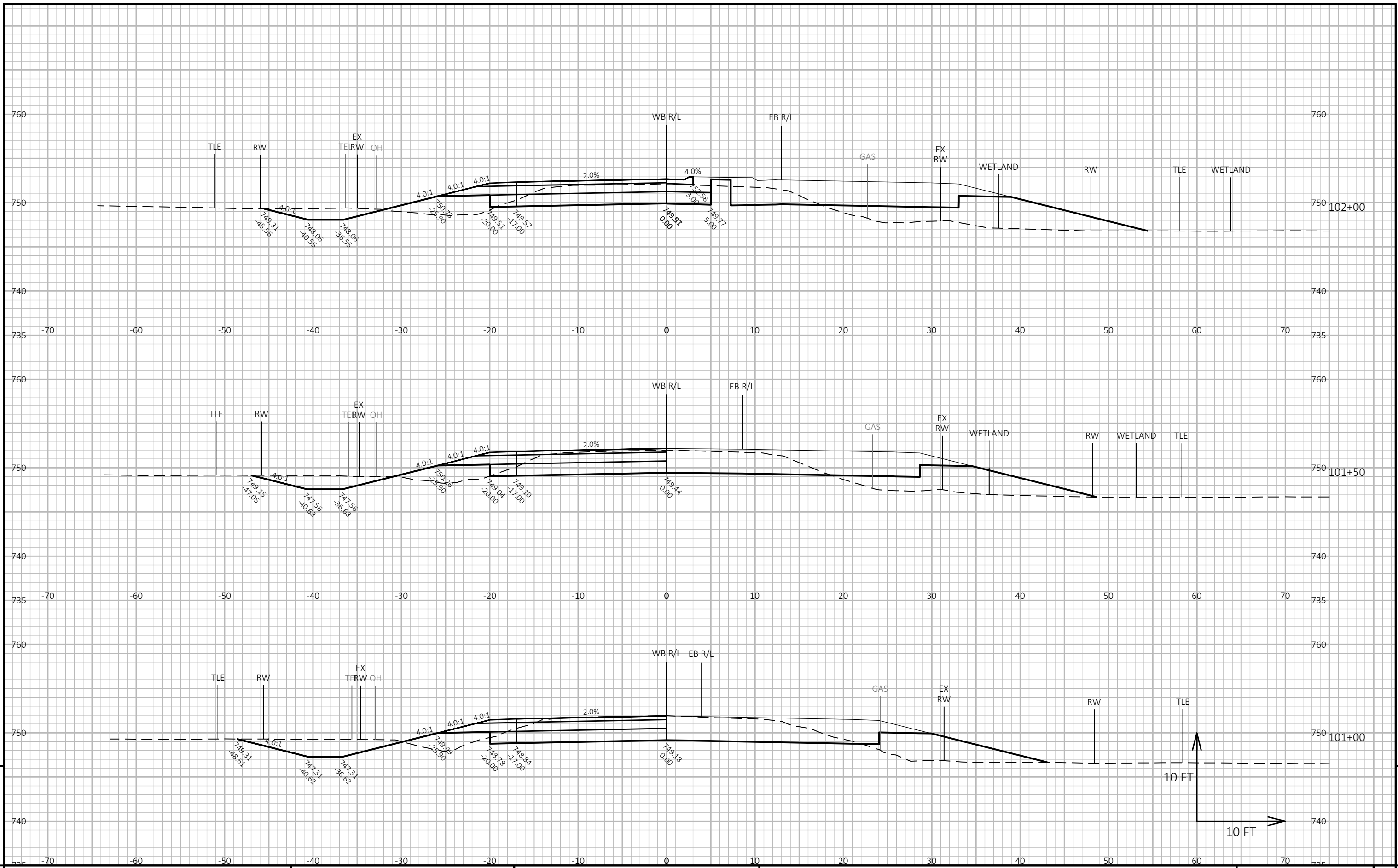

9

9

PROJECT NO: 2816-03-70      HWY: CTH U      COUNTY: RACINE      CROSS SECTIONS: CROSS SECTIONS - 7 MILE RD WB      SHEET      E

FILE NAME : Y:\54XX\5487.DP22.CTH.U.RCN.INTR.7.MILE.RD\CADD\28160300\SHEETS\090201-XS NEW.DWG      PLOT DATE : 10/23/2023 12:13 PM      PLOT BY : KATIE NAKLES      PLOT NAME :      PLOT SCALE : 1 IN:10 FT HORZ. / 1 IN:10 FT VERT.      WISDOT/CADD SHEET 49

LAYOUT NAME - WB2

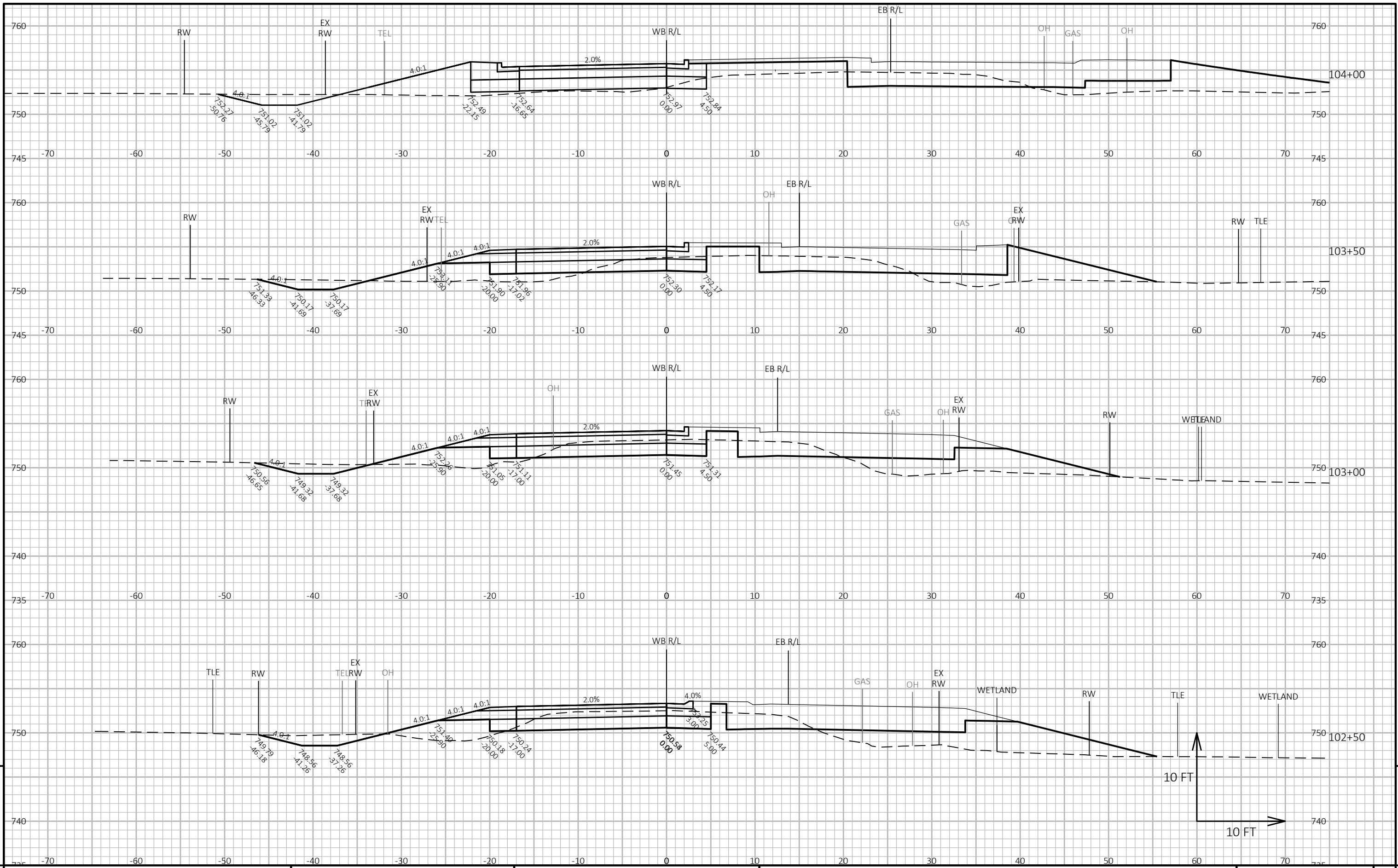

9

9

PROJECT NO: 2816-03-70      HWY: CTH U      COUNTY: RACINE      CROSS SECTIONS: CROSS SECTIONS - 7 MILE RD WB      SHEET      E

FILE NAME : Y:\54XX\5487.DP22.CTH.U.RCN.INTR.7.MILE.RD\CADDS\28160300\SHEETS\090201-XS NEW.DWG      PLOT DATE : 10/23/2023 12:13 PM      PLOT BY : KATIE NAKLES      PLOT NAME :      PLOT SCALE : 1 IN:10 FT HORZ. / 1 IN:10 FT VERT.      WISDOT/CADDS SHEET 49

LAYOUT NAME - WB3

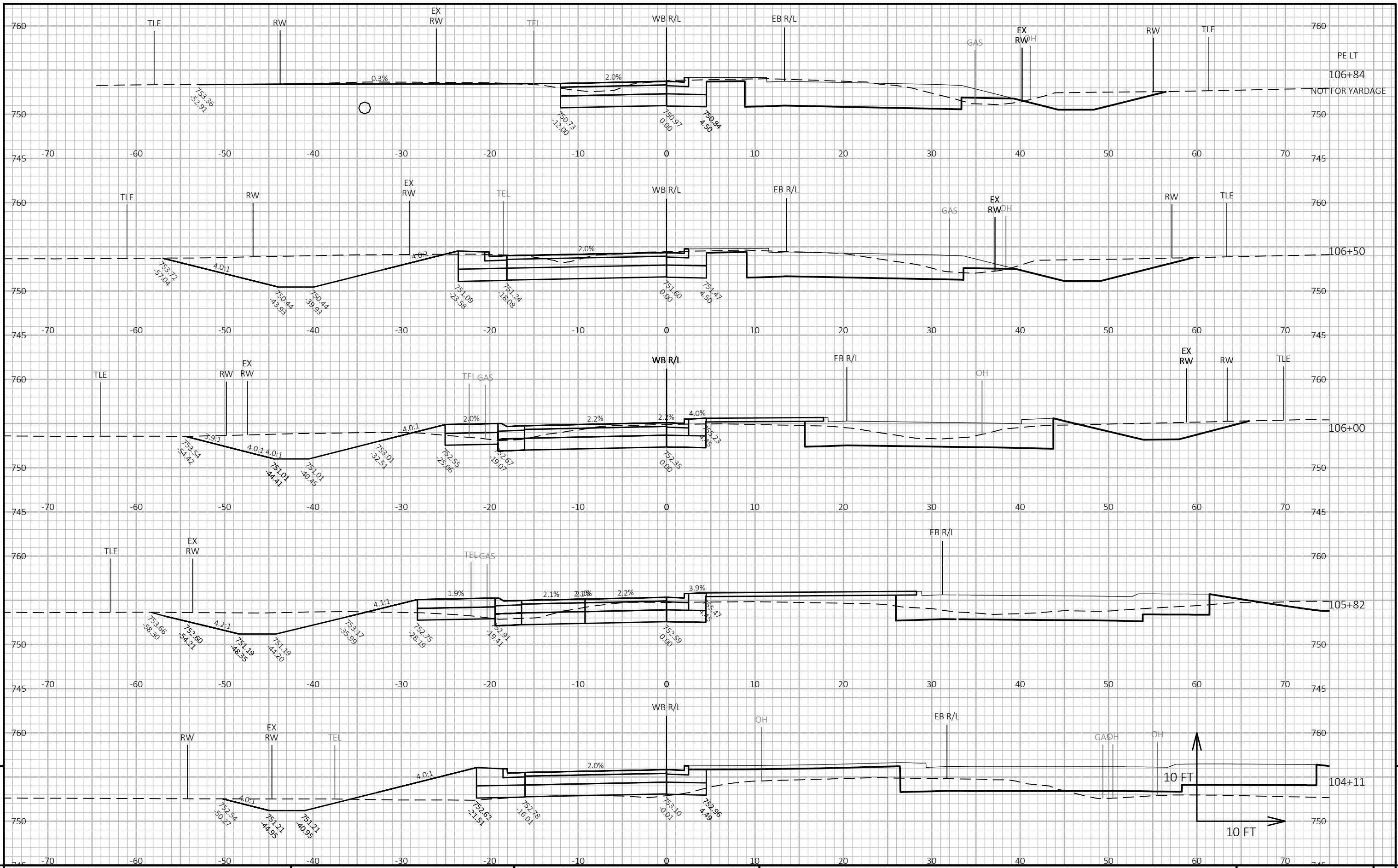

PROJECT NO: 2816-03-70      HWY: CTH U      COUNTY: RACINE      CROSS SECTIONS: CROSS SECTIONS - 7 MILE RD WB      SHEET      E

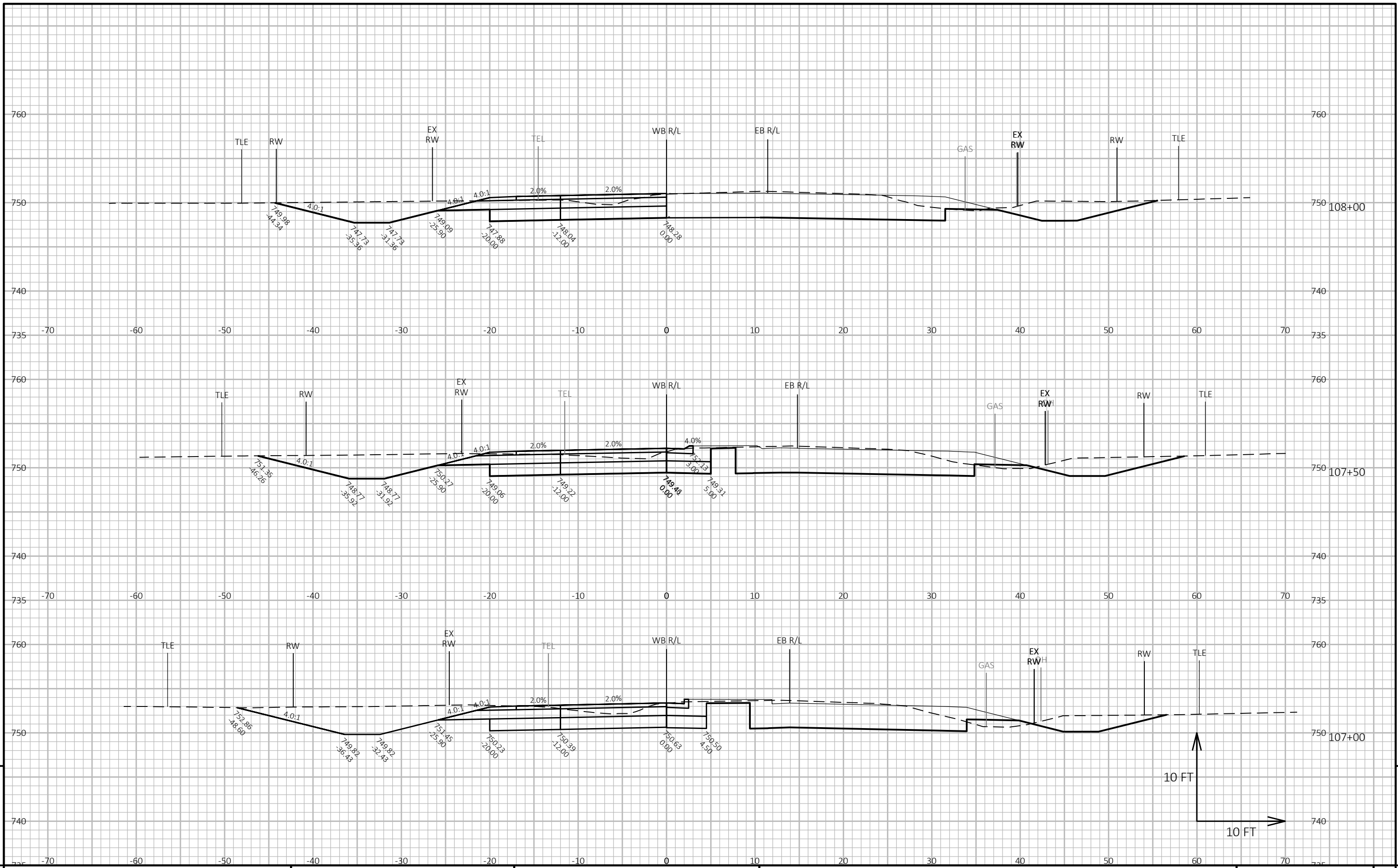

9

9

PROJECT NO: 2816-03-70      HWY: CTH U      COUNTY: RACINE      CROSS SECTIONS: CROSS SECTIONS - 7 MILE RD WB      SHEET E

FILE NAME : Y:\54XX\5487.DP22.CTH.U.RCN.INTR.7.MILE.RD\CADD\28160300\SHEETS\090201-XS.NEW.DWG      PLOT DATE : 10/23/2023 12:14 PM      PLOT BY : KATIE NAKLES      PLOT NAME :      PLOT SCALE : 1 IN:10 FT HORZ. / 1 IN:10 FT VERT.      WISDOT/CADD SHEET 49

LAYOUT NAME - WB5

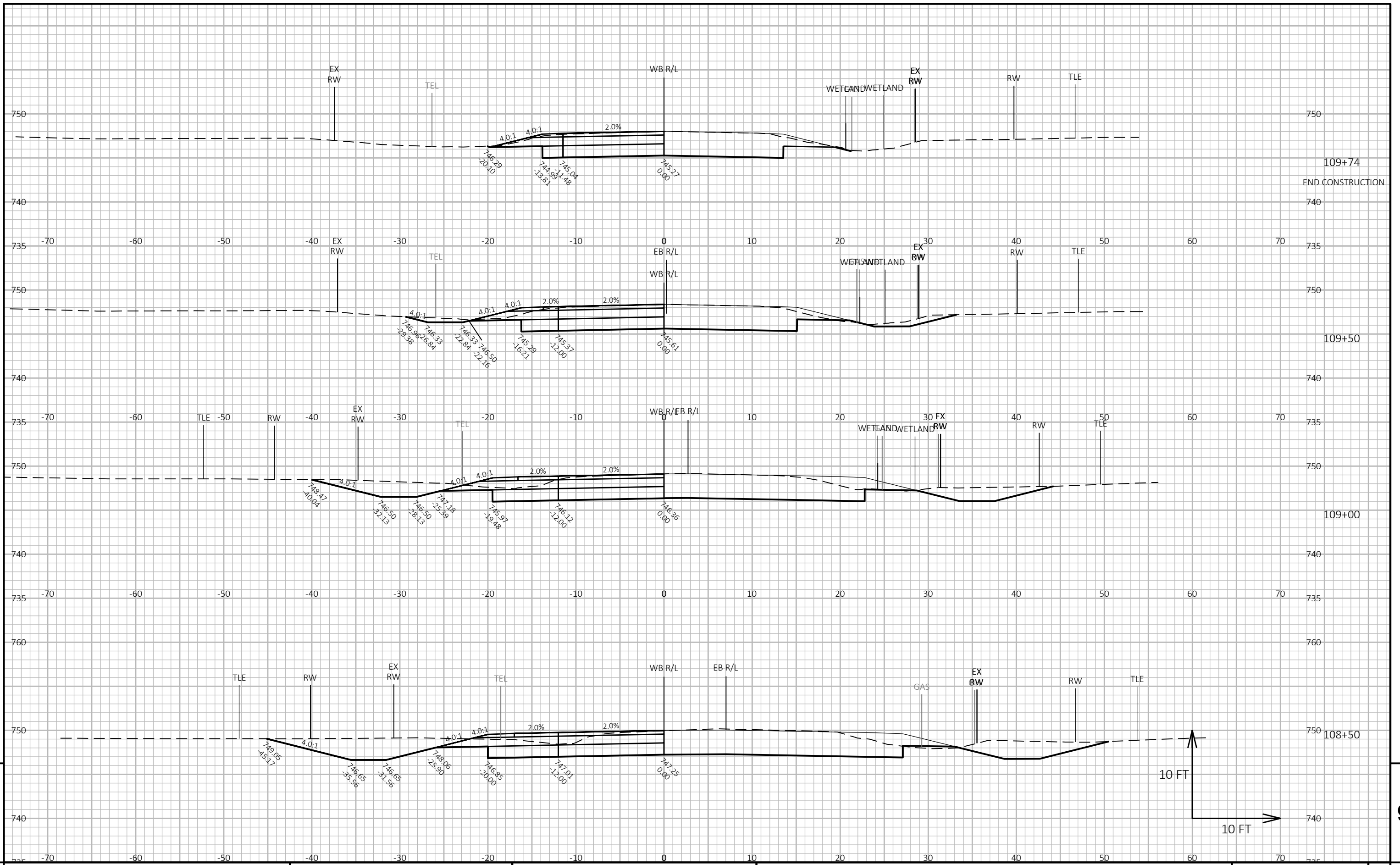

PROJECT NO: 2816-03-70      HWY: CTH U      COUNTY: RACINE      CROSS SECTIONS: CROSS SECTIONS - 7 MILE RD WB      SHEET 9





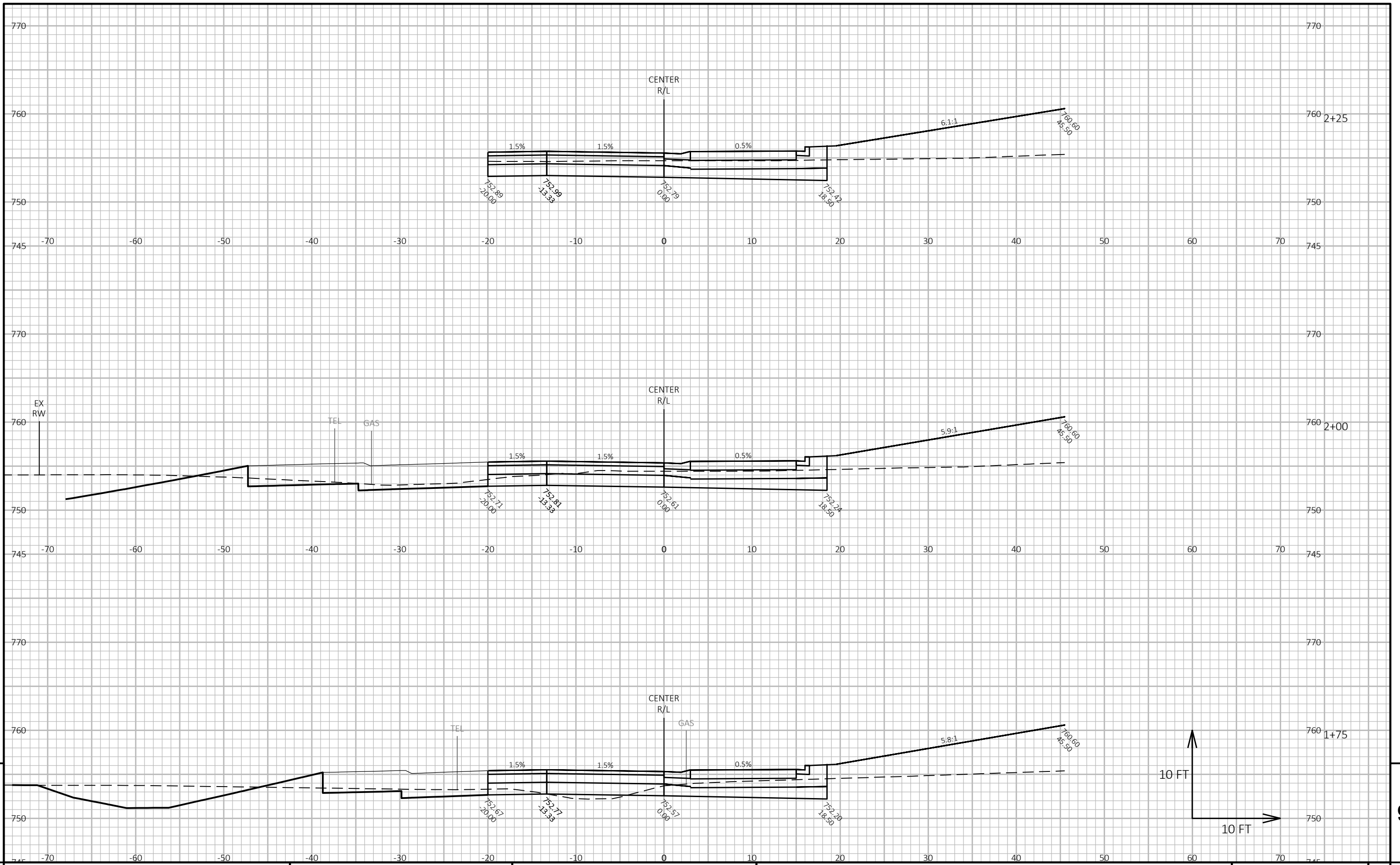

PROJECT NO: 2816-03-70      HWY: CTH U      COUNTY: RACINE      CROSS SECTIONS: CROSS SECTIONS - CENTER CIRCLE      SHEET 9

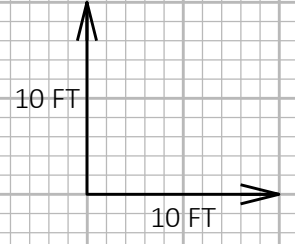
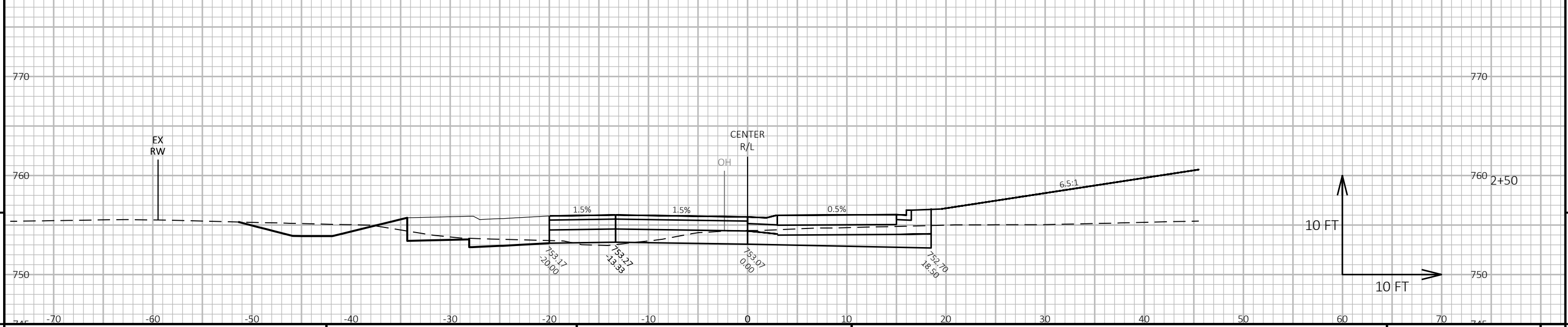
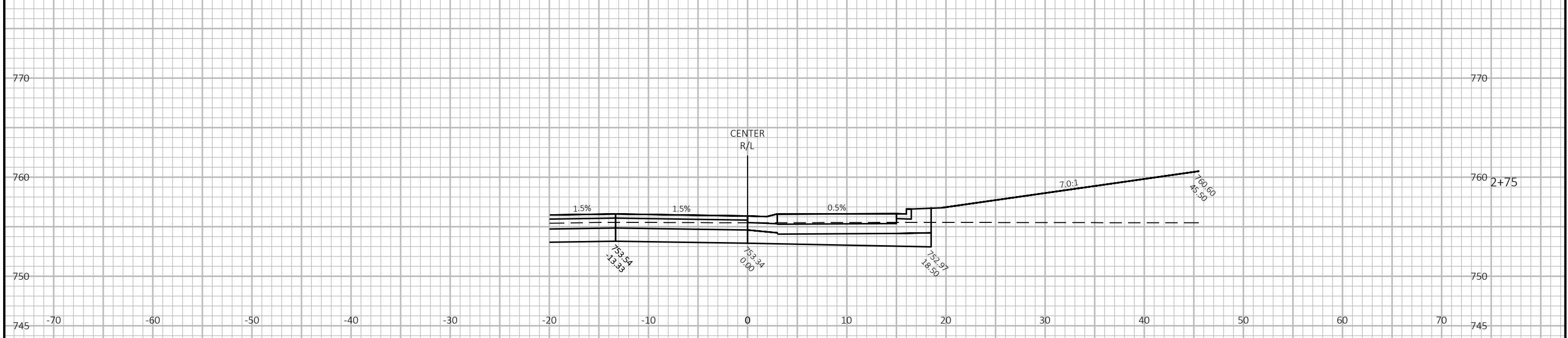
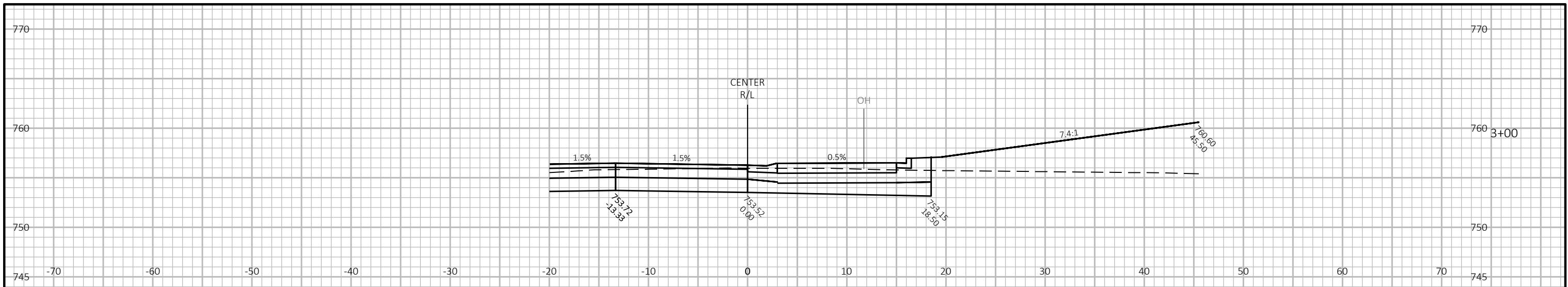

PROJECT NO: 2816-03-70      HWY: CTH U      COUNTY: RACINE      CROSS SECTIONS: CROSS SECTIONS - CENTER CIRCLE      SHEET      E

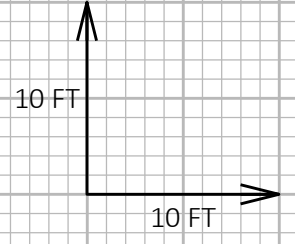
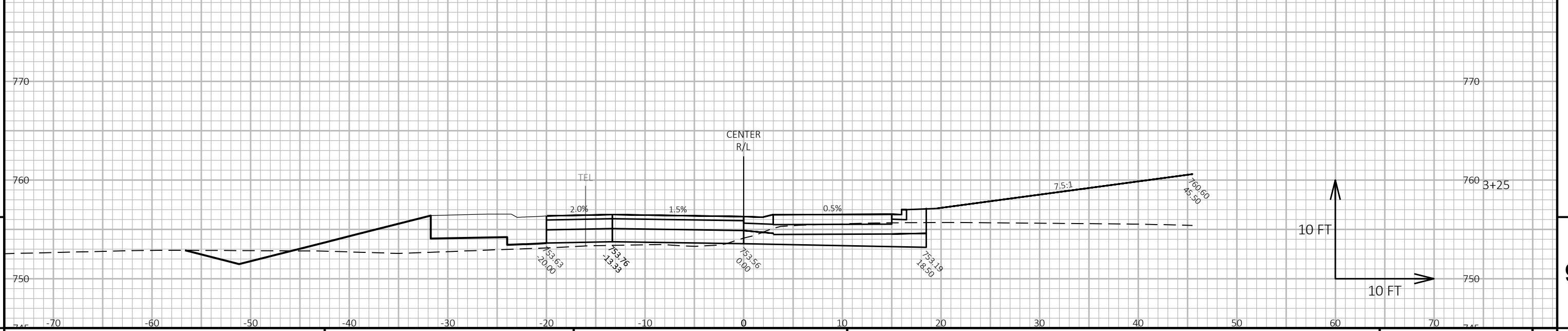
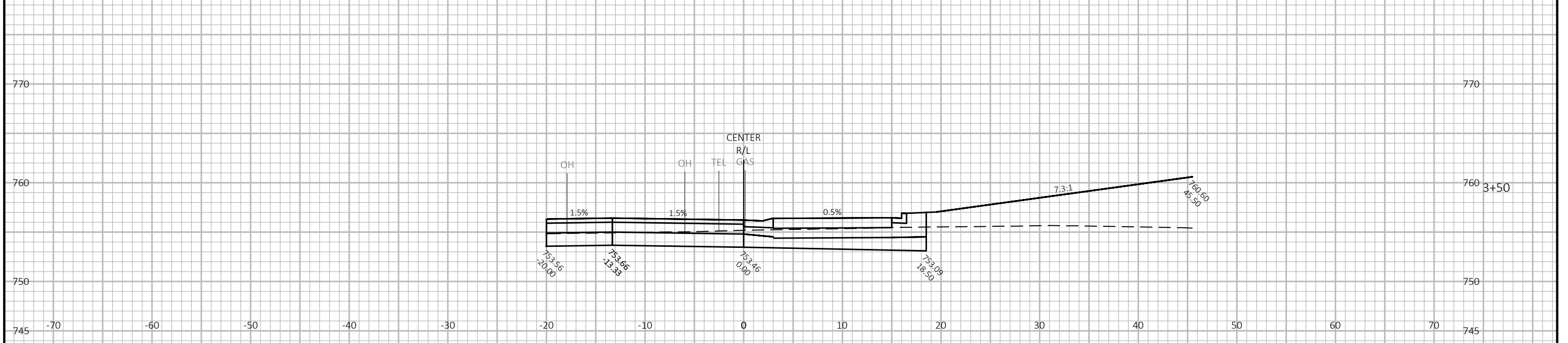
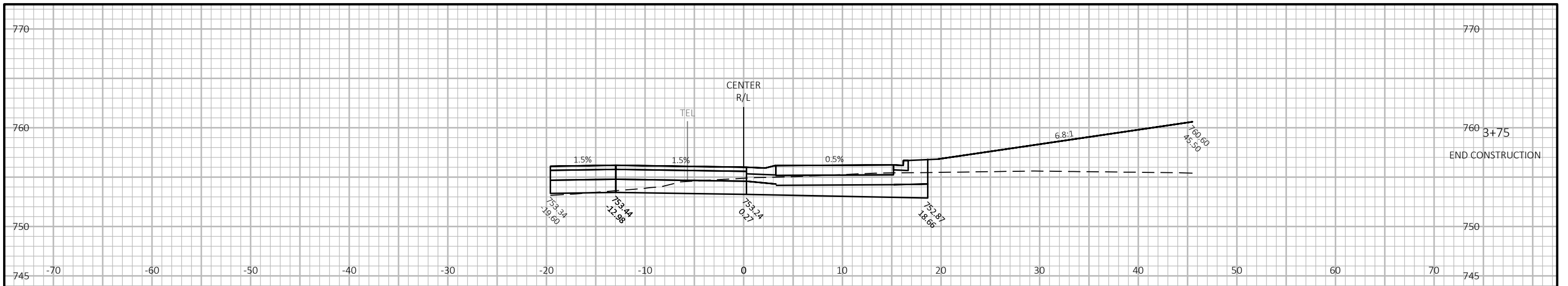

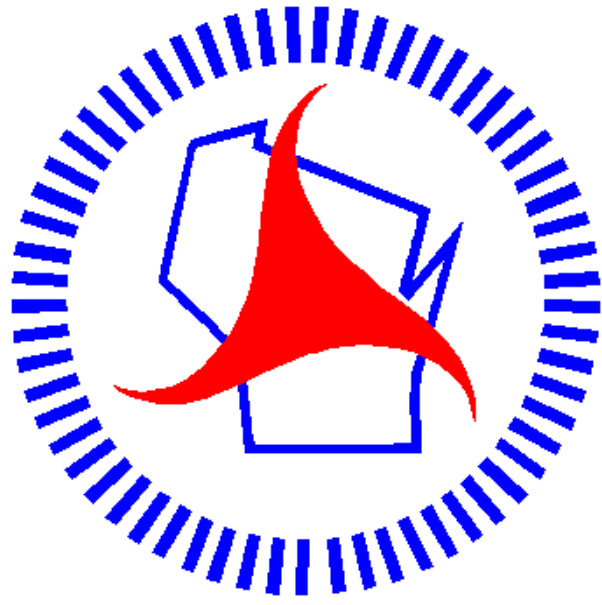

## ***Wisconsin Department of Transportation***

Dedicated people creating transportation solutions through innovation and exceptional service.

<http://www.dot.wisconsin.gov>