

ORDER OF SHEETS

Section No.	1	Title
Section No.	2	Typical Sections and Details
Section No.	3	Estimate of Quantities
Section No.	3	Miscellaneous Quantities
Section No.	4	Right of Way Plat
Section No.	5	Plan and Profile
Section No.	6	Standard Detail Drawings
Section No.	7	Sign Plates
<del>Section No.</del>	<del>8</del>	<del>Structure Plans</del>
Section No.	9	Computer Earthwork Data
Section No.	9	Cross Sections

TOTAL SHEETS = 274



19

DESIGN DESIGNATION

A.A.D.T. (2024)	=	1630
A.A.D.T. (2044)	=	1935
D.H.V.	=	242
D.D.	=	50/50
T.	=	5.8%
DESIGN SPEED	=	60 MPH
ESALS	=	219,000

CONVENTIONAL SYMBOLS

PLAN	
CORPORATE LIMITS	
PROPERTY LINE	
LOT LINE	
LIMITED HIGHWAY EASEMENT	
EXISTING RIGHT OF WAY	
PROPOSED OR NEW R/W LINE	
SLOPE INTERCEPT	
REFERENCE LINE	
EXISTING CULVERT	
PROPOSED CULVERT (Box or Pipe)	
COMBUSTIBLE FLUIDS	
MARSH AREA	
WOODED OR SHRUB AREA	

PROFILE	
GRADE LINE	
ORIGINAL GROUND	
MARSH OR ROCK PROFILE (To be noted as such)	
SPECIAL DITCH	
GRADE ELEVATION	
CULVERT (Profile View)	
UTILITIES	
ELECTRIC	
FIBER OPTIC	
GAS	
SANITARY SEWER	
STORM SEWER	
TELEPHONE	
WATER	
UTILITY PEDESTAL	
POWER POLE	
TELEPHONE POLE	

# STATE OF WISCONSIN DEPARTMENT OF TRANSPORTATION

## PLAN OF PROPOSED IMPROVEMENT

### KEWAUNEE - RYANS CORNER

STH 29 TO CTH L

CTH C

KEWAUNEE COUNTY

STATE PROJECT NUMBER  
**4390-07-71**

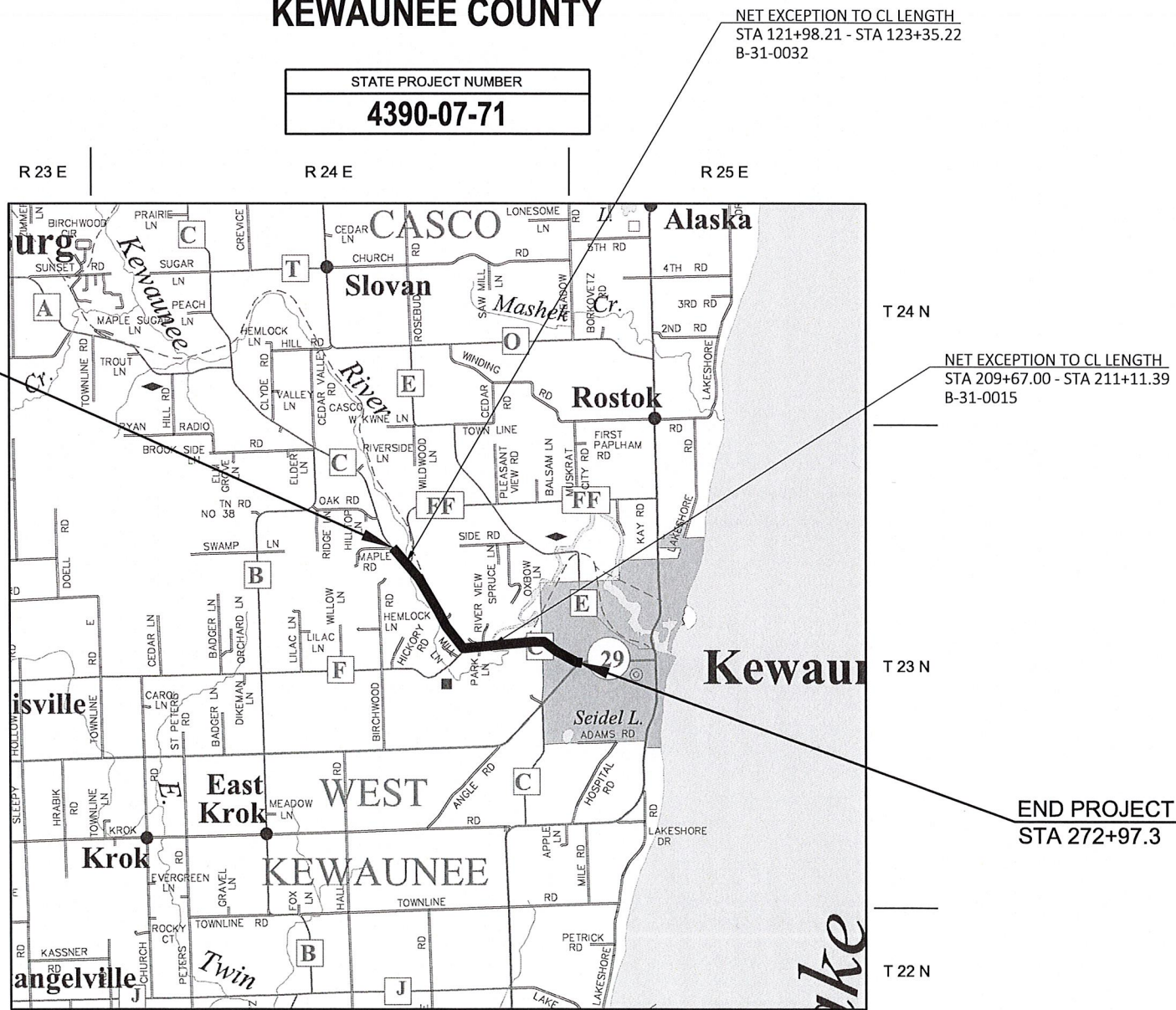

BEGIN PROJECT  
STA 109+25  
Y=442443.270  
X=257029.740

NET EXCEPTION TO CL LENGTH  
STA 121+98.21 - STA 123+35.22  
B-31-0032

NET EXCEPTION TO CL LENGTH  
STA 209+67.00 - STA 211+11.39  
B-31-0015

END PROJECT  
STA 272+97.3

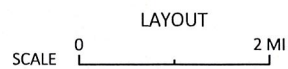

TOTAL NET LENGTH OF CENTERLINE = 3.048 MI

HORIZONTAL POSITIONS SHOWN ON THIS PLAN ARE WISCONSIN COORDINATE REFERENCE SYSTEM (WISCRS), KEWAUNEE COUNTY, NAD83 (2011), IN U.S. SURVEY FEET. POSITIONS SHOWN ARE GRID COORDINATES, GRID BEARINGS, AND GRID DISTANCES. GRID DISTANCES ARE THE SAME AS GROUND DISTANCES. ELEVATIONS ARE REFERENCED TO NAVD 88 (2012). GPS DERIVED ELEVATIONS ARE BASED ON GEOID 12B.

STATE PROJECT	FEDERAL PROJECT	
	PROJECT	CONTRACT
4390-07-71	WISC 2024286	1

ACCEPTED FOR  
KEWAUNEE COUNTY

10-24-23 *Joel Eury*  
DATE COUNTY HIGHWAY COMMISSIONER

ORIGINAL PLANS PREPARED BY

**AYRES**

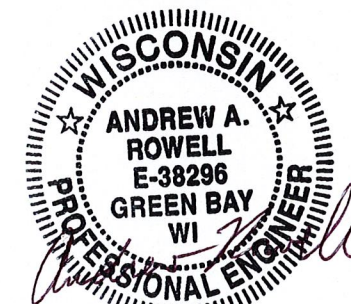

10/24/2023  
(Date)

STATE OF WISCONSIN  
DEPARTMENT OF TRANSPORTATION

PREPARED BY	
Surveyor	AYRES ASSOCIATES INC
Designer	AYRES ASSOCIATES INC
Project Manager	DOUG KIRST
Regional Supervisor	BRIAN EDWARDS

APPROVED FOR THE DEPARTMENT  
DATE: 1/4/2024 *Doug Kirst*  
(Signature)

E

GENERAL NOTES

THE LOCATIONS OF EXISTING UTILITY FACILITIES AS SHOWN ON THE PLANS ARE APPROXIMATE. THERE MAY BE OTHER UTILITY FACILITIES WITHIN THE PROJECT AREA THAT ARE NOT SHOWN.

REFERENCE LINE REFERS TO ALIGNMENT AND STATIONING, CENTERLINE REFERS TO EXISTING ROADWAY CENTERLINE. REFERENCE LINE AND CENTERLINE ARE NOT COINCIDENTAL.

NO TREES OR SHRUBS ARE TO BE REMOVED WITHOUT APPROVAL OF THE ENGINEER.

THE EXACT LOCATIONS OF EROSION CONTROL ITEMS SHALL BE DETERMINED BY THE ENGINEER IN THE FIELD.

DISTURBED AREAS WITHIN THE RIGHT-OF-WAY, EXCEPT THE AREAS WITHIN THE FINISHED SUBGRADE SHOULDER POINTS, ARE TO BE RESTORED WITH FERTILIZER, SEED, AND EROSION MAT WITHIN 5 CALENDAR DAYS OF FINAL GRADING/TOPSOILING.

INLET AND DISCHARGE ELEVATIONS FOR CULVERTS SHOWN ON THE PLAN MAY BE ADJUSTED BY THE ENGINEER TO FIT FIELD CONDITIONS.

A BUTT JOINT AND VERTICAL FACE IS REQUIRED WHERE NEW HMA PAVEMENT MEETS EXISTING HMA PAVEMENT.

RADIUS POINTS, UNLESS OTHERWISE NOTED, ARE TO THE FACE OF CURB.

ORDER OF SECTION 2 DETAIL SHEETS

- GENERAL NOTES
- TYPICAL SECTIONS
- CONSTRUCTION DETAILS
- PLAN DETAILS
- EROSION CONTROL
- STORM SEWER PLAN

DNR LIAISON

MATT SCHAEVE  
 DNR NORTHEAST REGIONAL HEADQUARTERS  
 2984 SHAWANO AVENUE  
 GREEN BAY, WI 54313  
 (920)366-1544  
 matthew.shcaeve@wisconsin.gov

UTILITIES CONTACTS

ELECTRICITY

WISCONSIN PUBLIC SERVICE CORPORATION  
 JUSTIN VEESER  
 2580 S. ASHLAND AVENUE  
 GREEN BAY, WI 54304  
 PHONE: (920) 493-1364  
 justin.veeser@wisconsinpublicservice.com

GAS / PETROLEUM

WISCONSIN PUBLIC SERVICE CORPORATION  
 JOEL SAWICKI  
 800 COLUMBUS STREET  
 P.O. BOX 236  
 TWO RIVERS, WI 54241-0236  
 PHONE: (920) 657-1862  
 joel.sawicki@wisconsinpublicservice.com

COMMUNICATIONS

AT&T DISTRIBUTION  
 CHUCK BARTLET  
 70 E DIVISION ST  
 FOND DU LAC, WI 54935-4311  
 PHONE: (920) 929-1013  
 CB1461@att.com

BUG TUSSEL  
 DUSTIN TEAFF  
 KES EXCAVATING SERVICES, LLC  
 1262 CAMBER CT  
 DE PERE, WI 54115  
 PHONE: (920) 254-3539  
 dustin.teaff@KESexcavating.com

CHARTER COMMUNICATIONS  
 SCOTT R DeCLARK  
 3545 PLANK ROAD  
 APPLETON, WI 54915  
 PHONE: (920) 378-0440  
 scott.declark@charter.com

WATER AND SEWER

CITY OF KEWAUNEE  
 NATHAN SEILER  
 401 5TH STREET  
 KEWAUNEE, WI 54216  
 PHONE: (920)388-5000  
 nseiler@cityofkewaunee.org

**RUNOFF COEFFICIENT TABLE**

	HYDROLOGIC SOIL GROUP											
	A			B			C			D		
	SLOPE RANGE (PERCENT)			SLOPE RANGE (PERCENT)			SLOPE RANGE (PERCENT)			SLOPE RANGE (PERCENT)		
LAND USE:	0-2	2-6	6 & OVER	0-2	2-6	6 & OVER	0-2	2-6	6 & OVER	0-2	2-6	6 & OVER
ROW CROPS	.08 .22	.16 .30	.22 .38	.12 .26	.20 .34	.27 .44	.15 .30	.24 .37	.33 .50	.19 .34	.28 .41	.38 .56
MEDIAN STRIP-TURF	.19 .24	.20 .26	.24 .30	.19 .25	.22 .28	.26 .33	.20 .26	.23 .30	.30 .37	.20 .27	.25 .32	.30 .40
SIDE SLOPE-TURF			.25 .32			.27 .34			.28 .36			.30 .38
PAVEMENT:												
ASPHALT	.70 - .95											
CONCRETE	.80 - .95											
BRICK	.70 - .80											
DRIVES, WALKS	.75 - .85											
ROOFS	.75 - .95											
GRAVEL ROADS, SHOULDERS	.40 - .60											

TOTAL PROJECT AREA = 10.5 ACRES  
 TOTAL AREA EXPECTED TO BE DISTURBED BY CONSTRUCTION ACTIVITIES = 11.5 ACRES



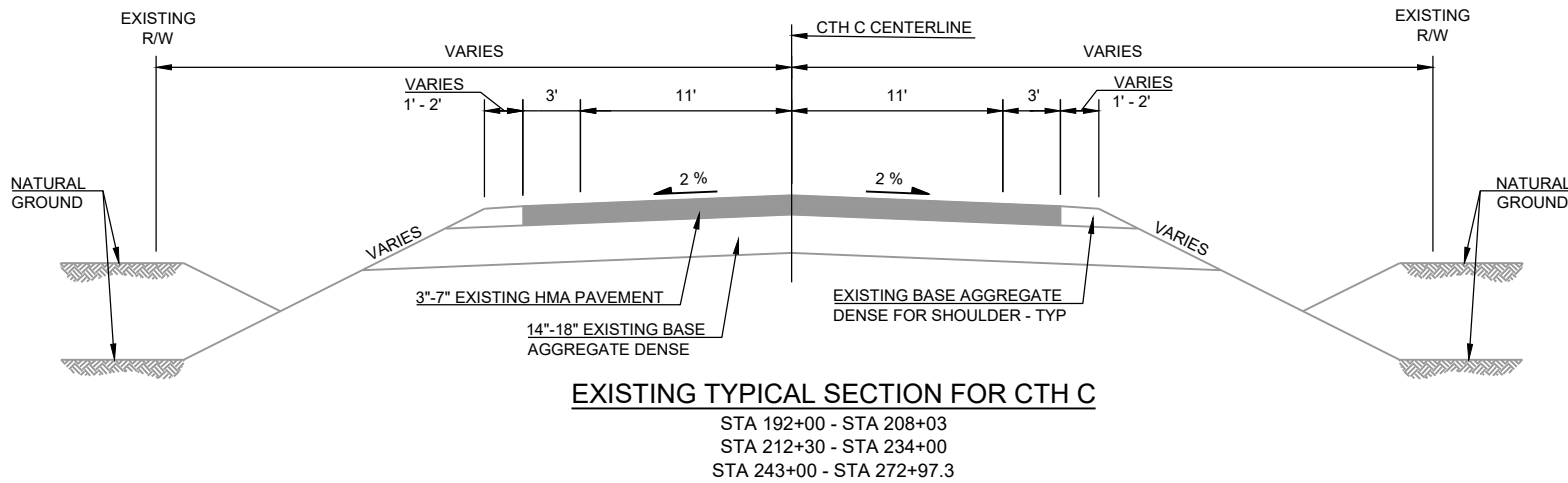
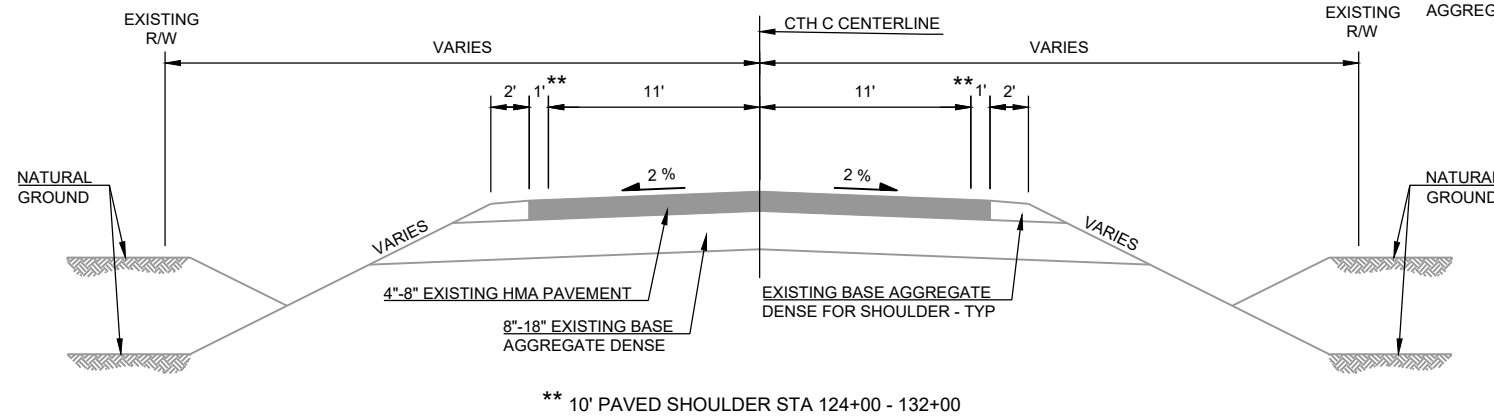
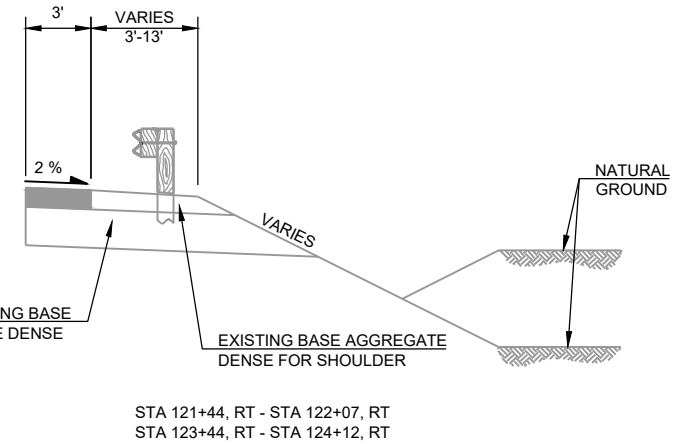
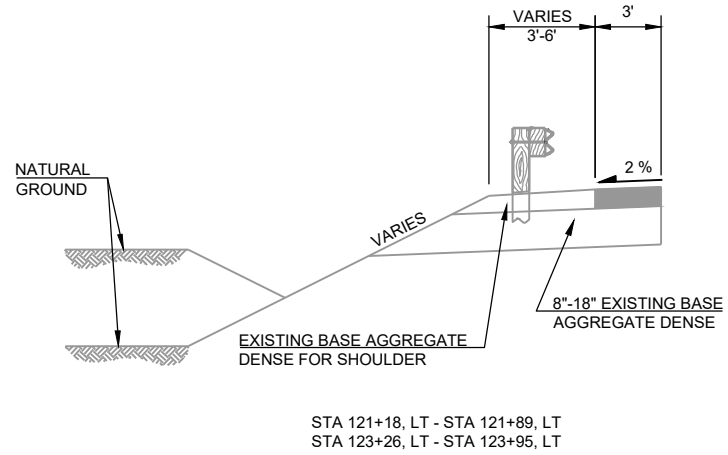
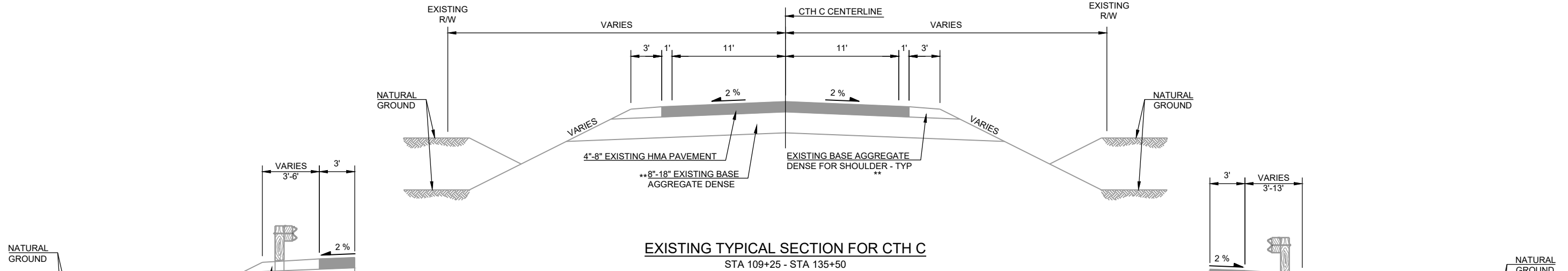

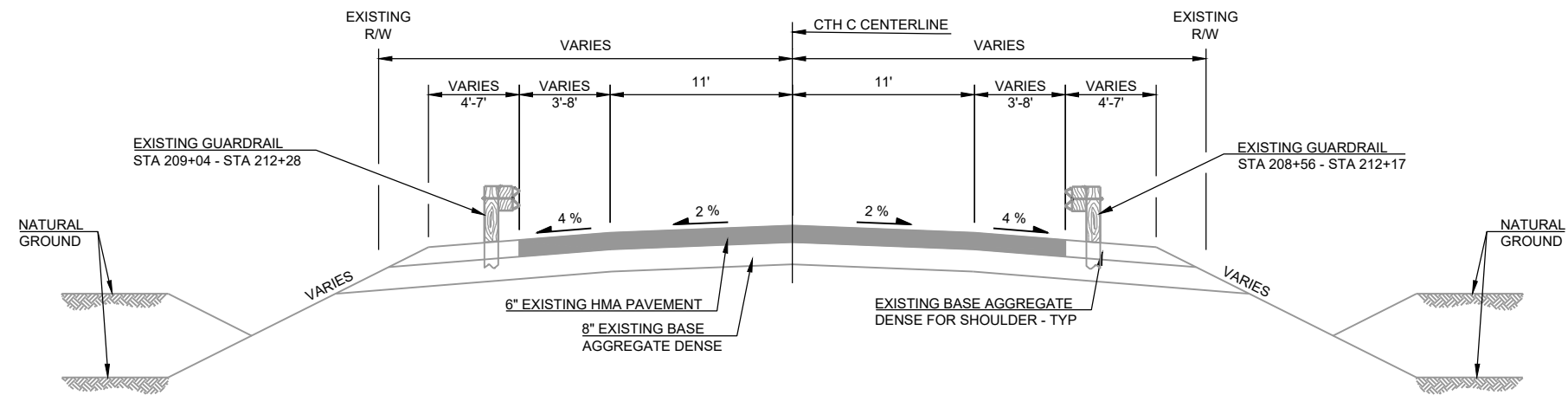

**EXISTING TYPICAL SECTION FOR CTH C**

STA 208+03 - STA 209+85  
 STA 211+02 - STA 212+30  
 STA 234+00 - STA 243+00



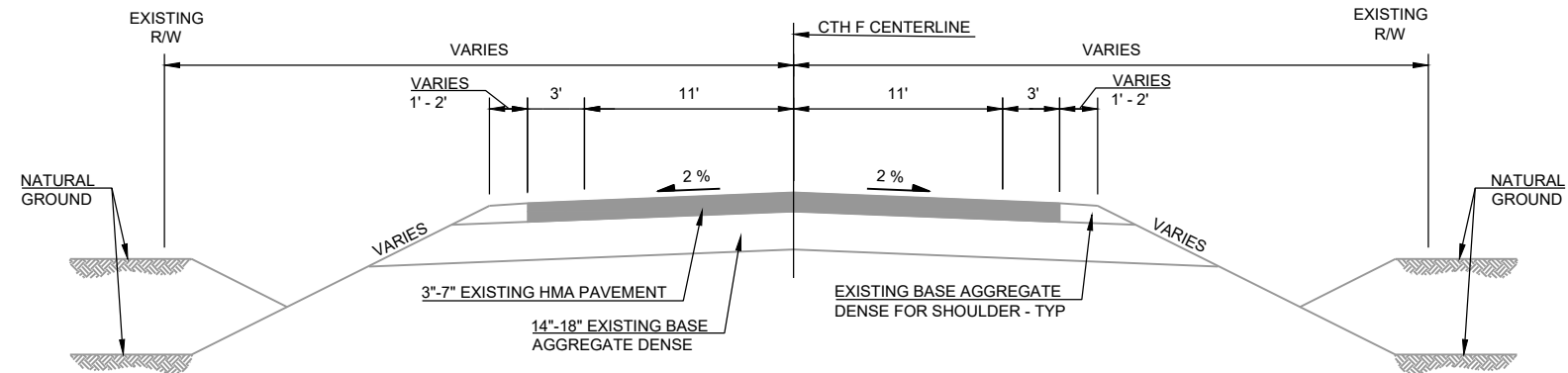

**EXISTING TYPICAL SECTION FOR CTH F**  
 STA 327+71.8 - STA 329+50

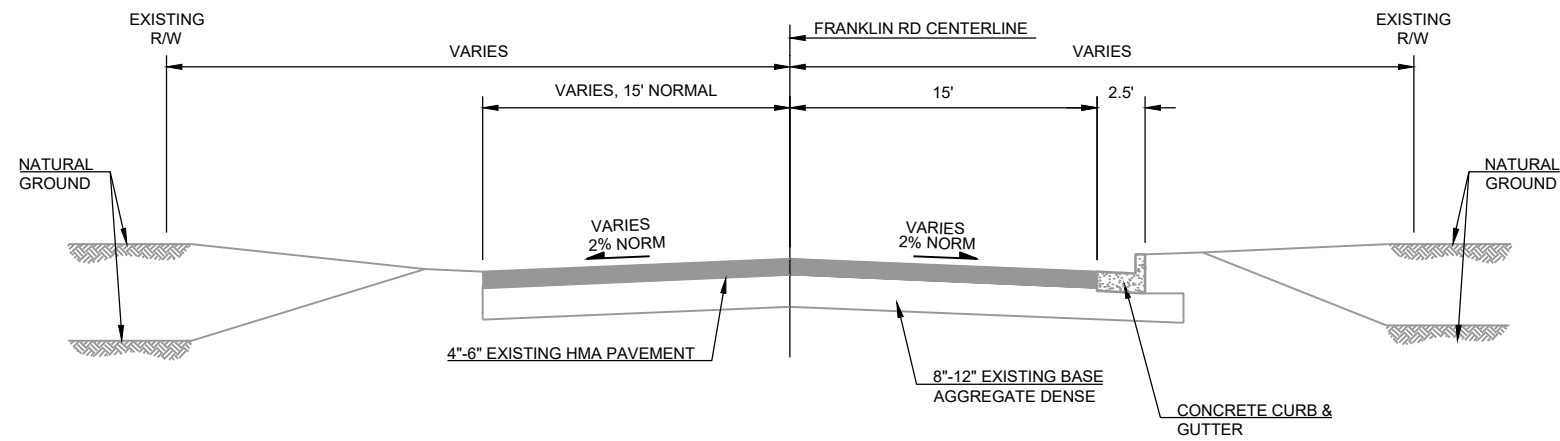

**EXISTING TYPICAL SECTION FOR FRANKLIN RD**  
 STA 401+60 - STA 402+89.22

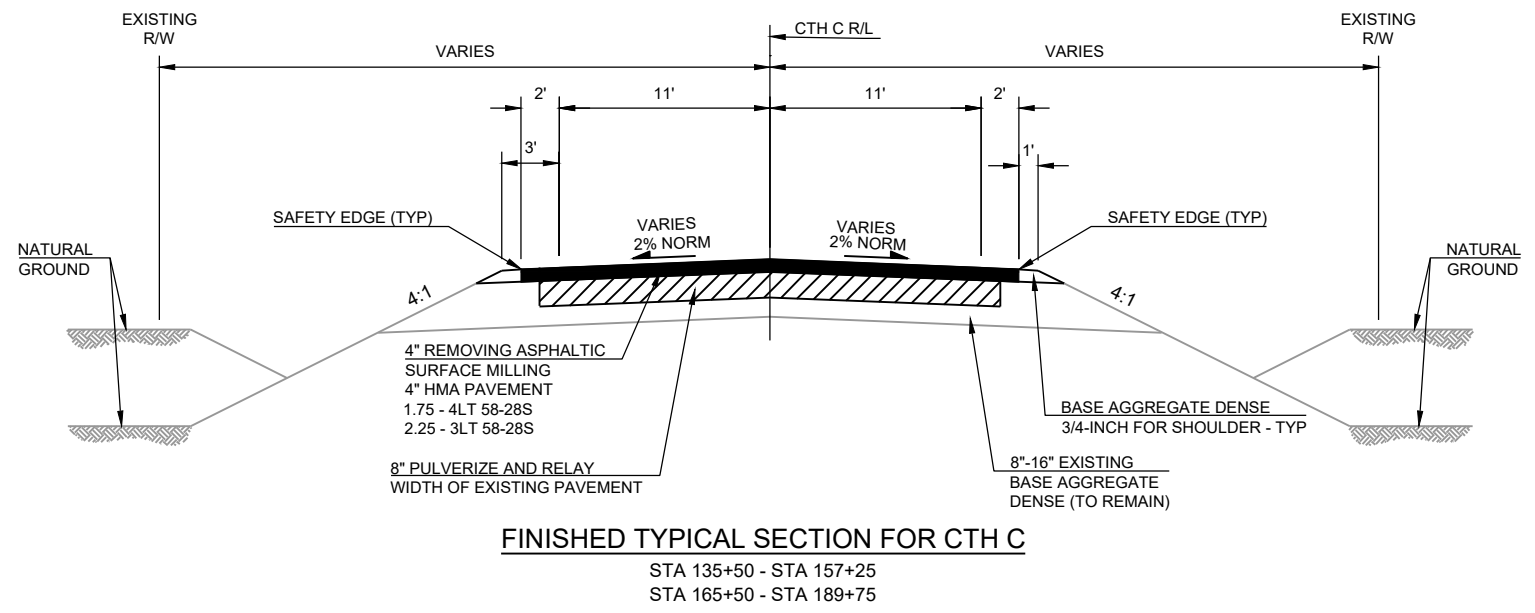
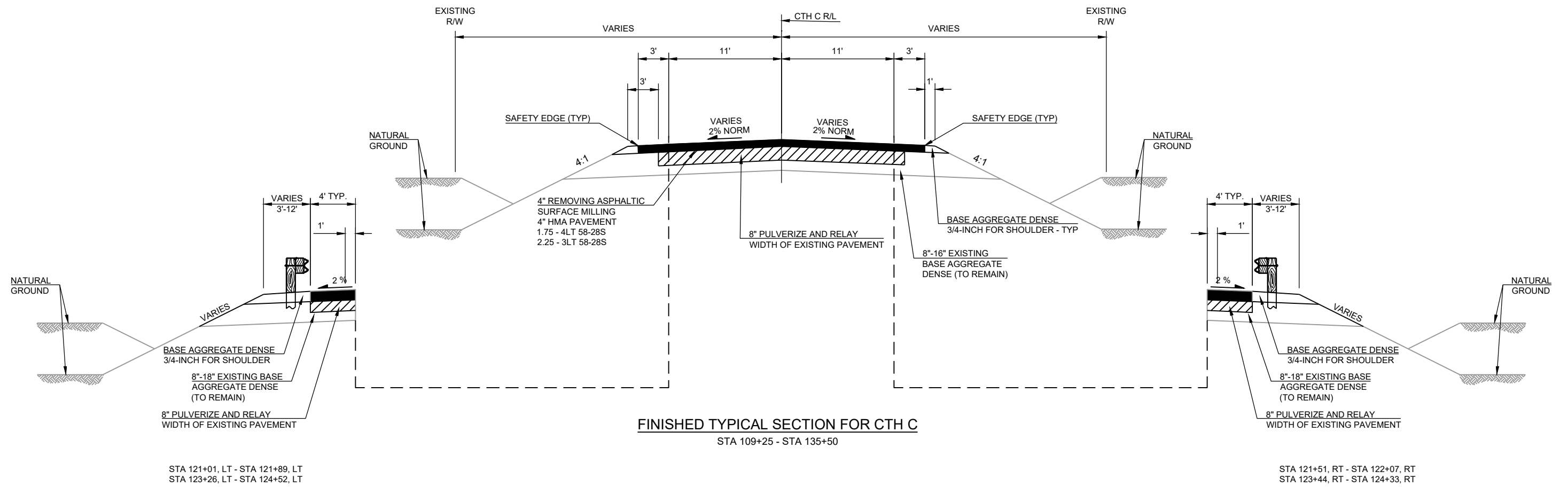

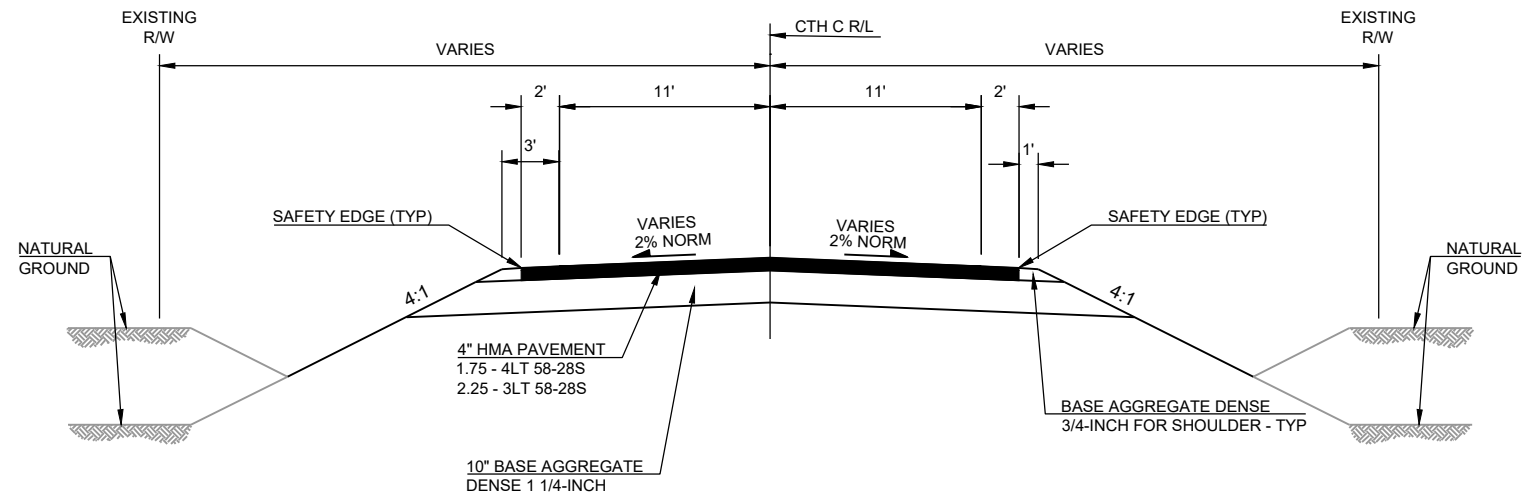

**FINISHED TYPICAL SECTION FOR CTH C**  
 STA 157+25 - STA 165+50

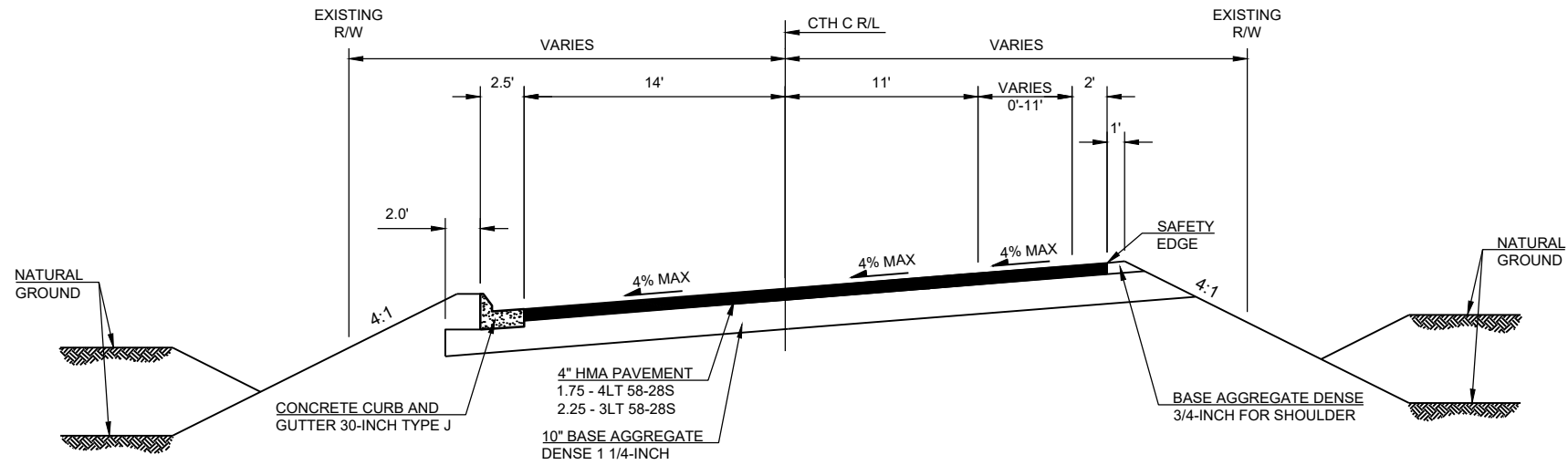

**FINISHED TYPICAL SECTION FOR CTH C**  
 STA 189+75 - STA 193+17.5

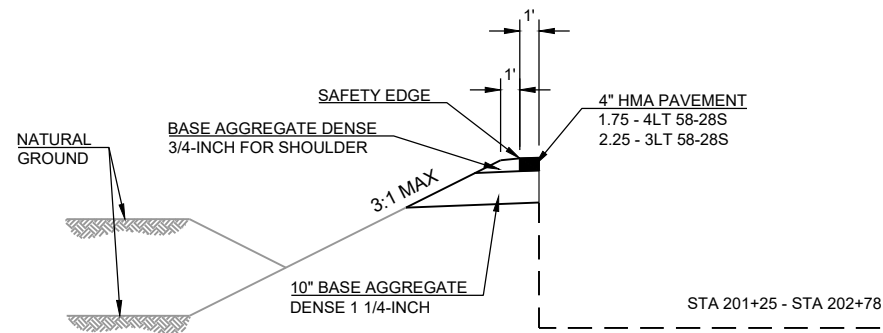
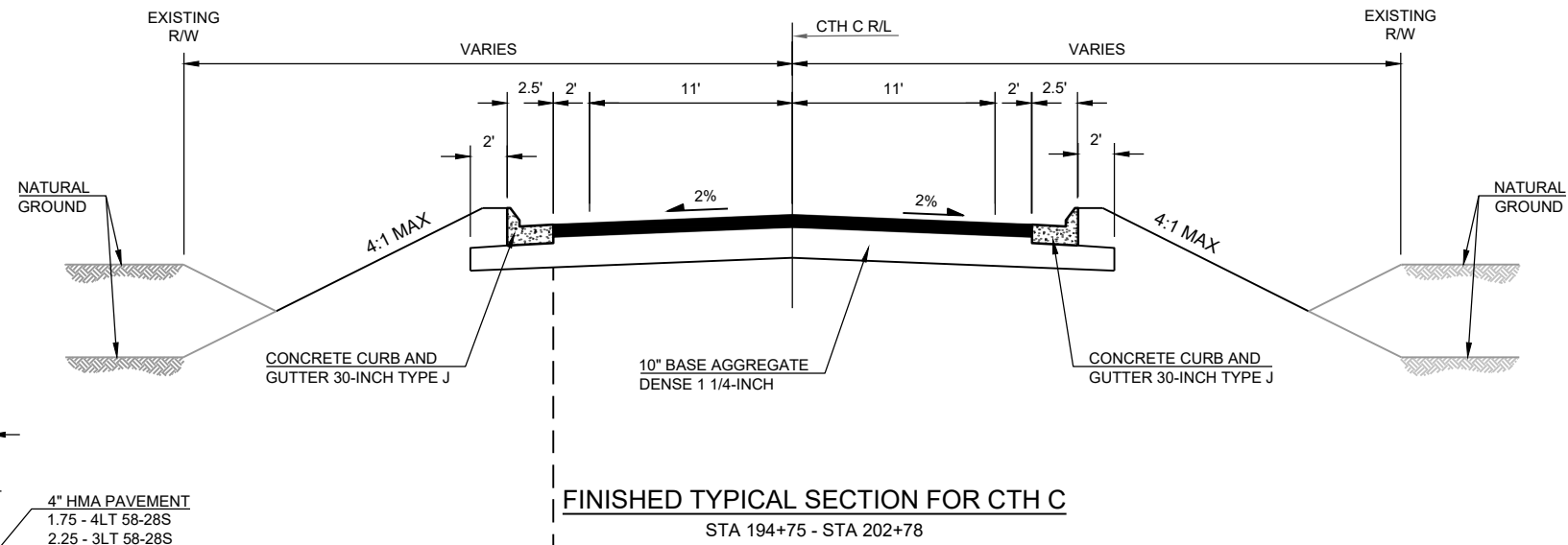
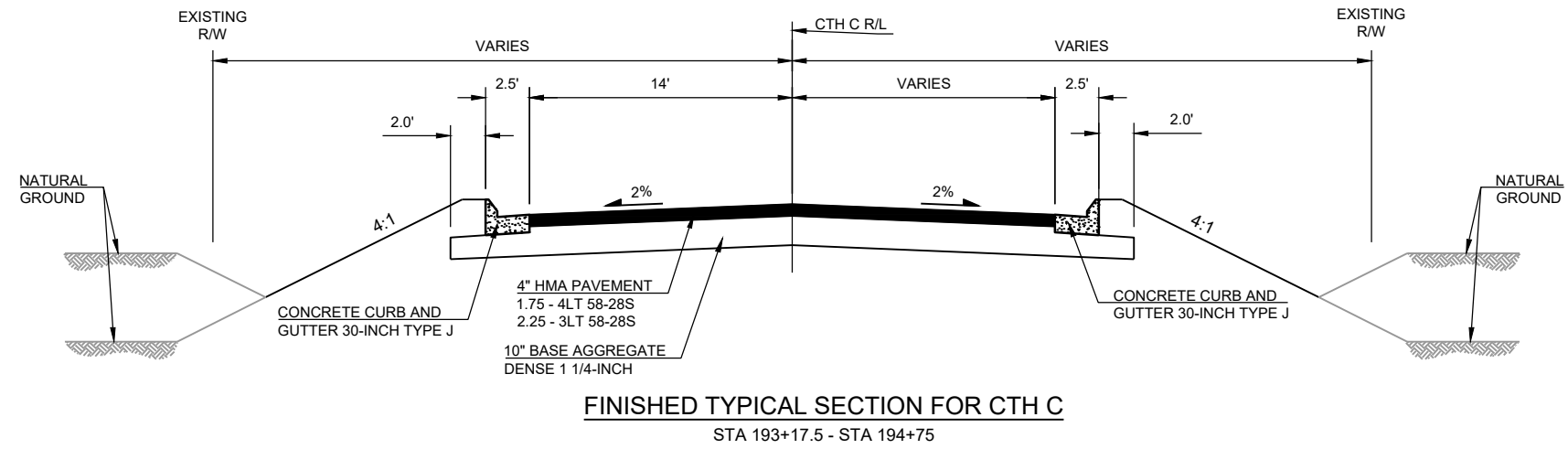



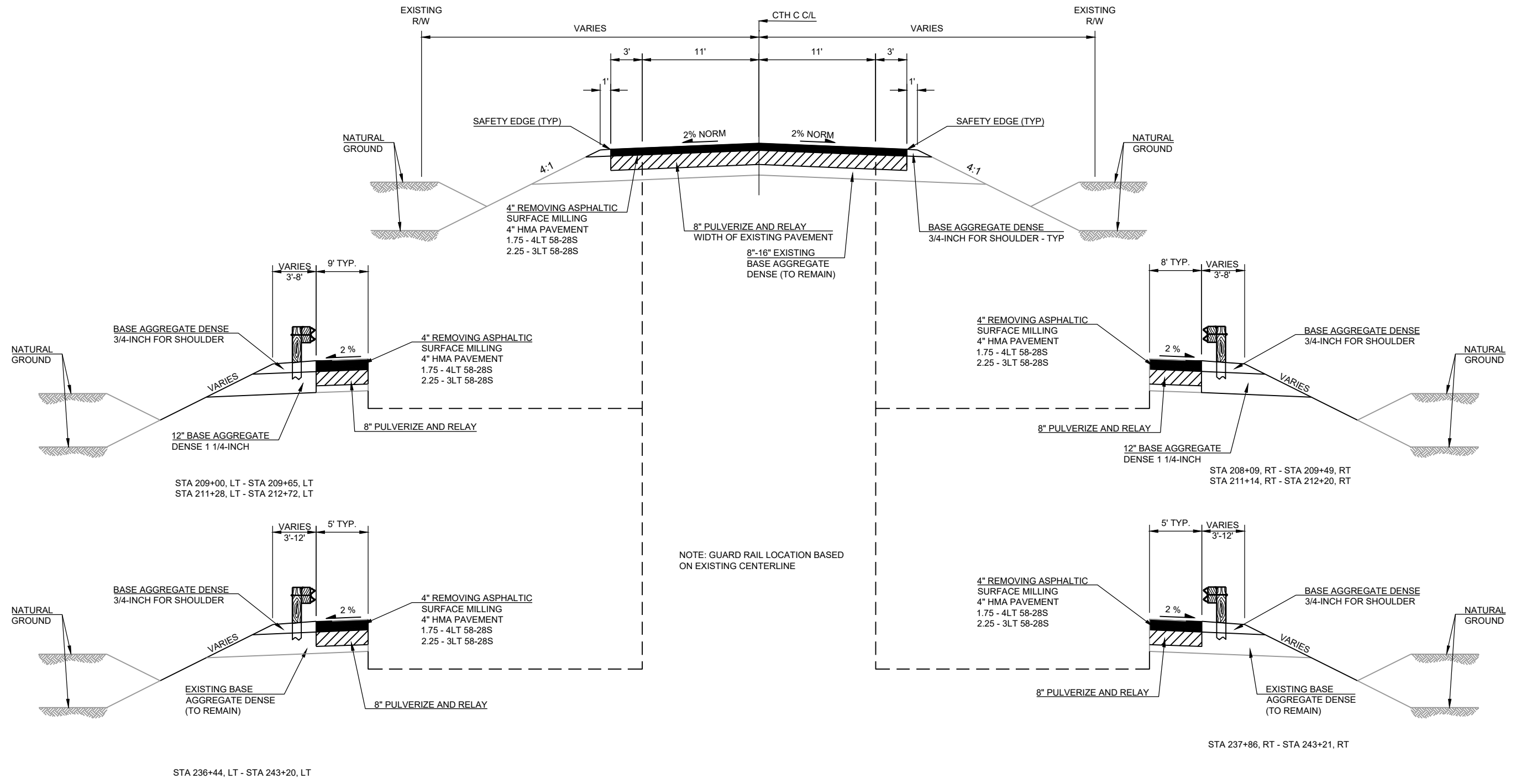

**FINISHED TYPICAL SECTION FOR CTH C**  
 STA 202+78 - STA 214+00  
 STA 236+00 - STA 243+50

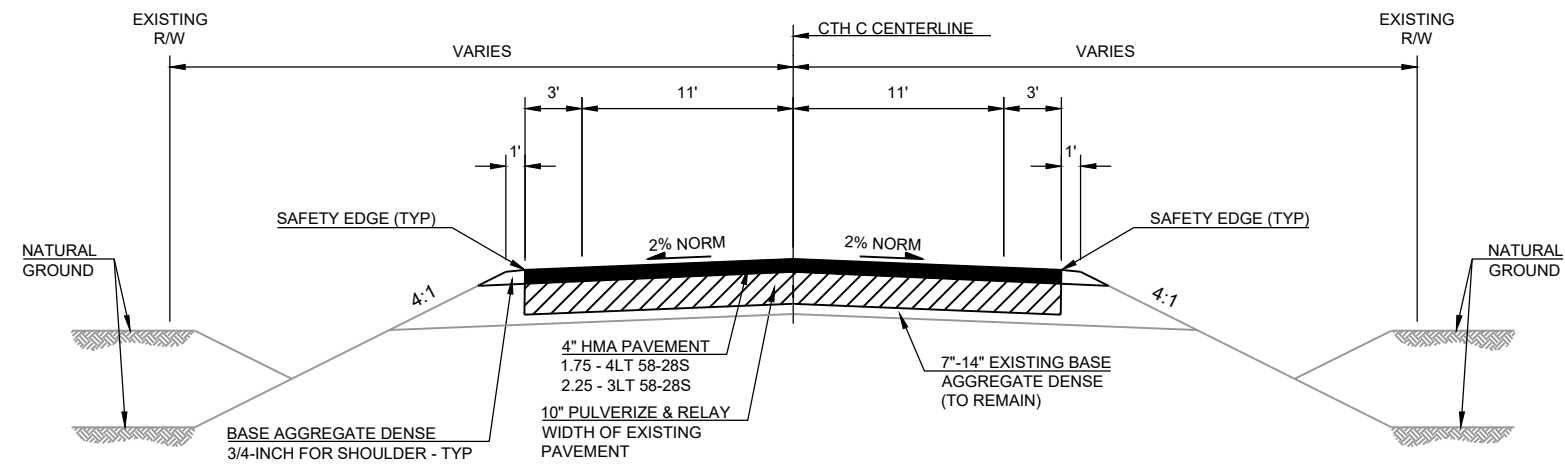

**FINISHED TYPICAL SECTION FOR CTH C**

STA 214+00 - STA 236+00  
STA 243+50 - STA 268+25

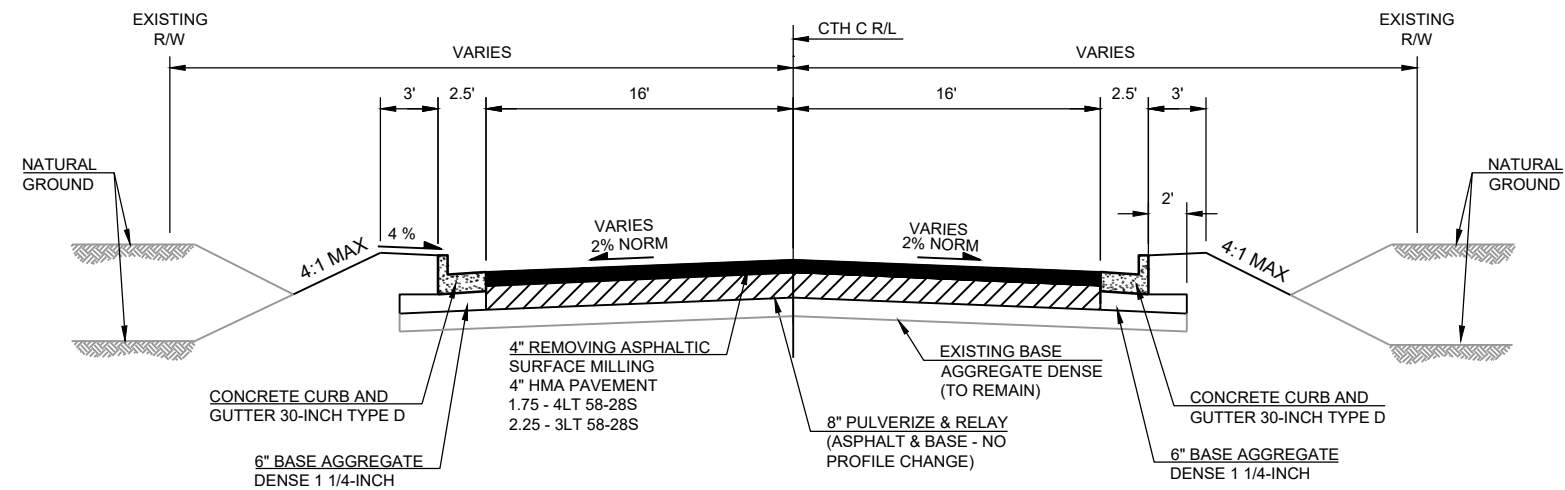

**FINISHED TYPICAL SECTION FOR CTH C**

STA 268+25 - STA 272+97.3

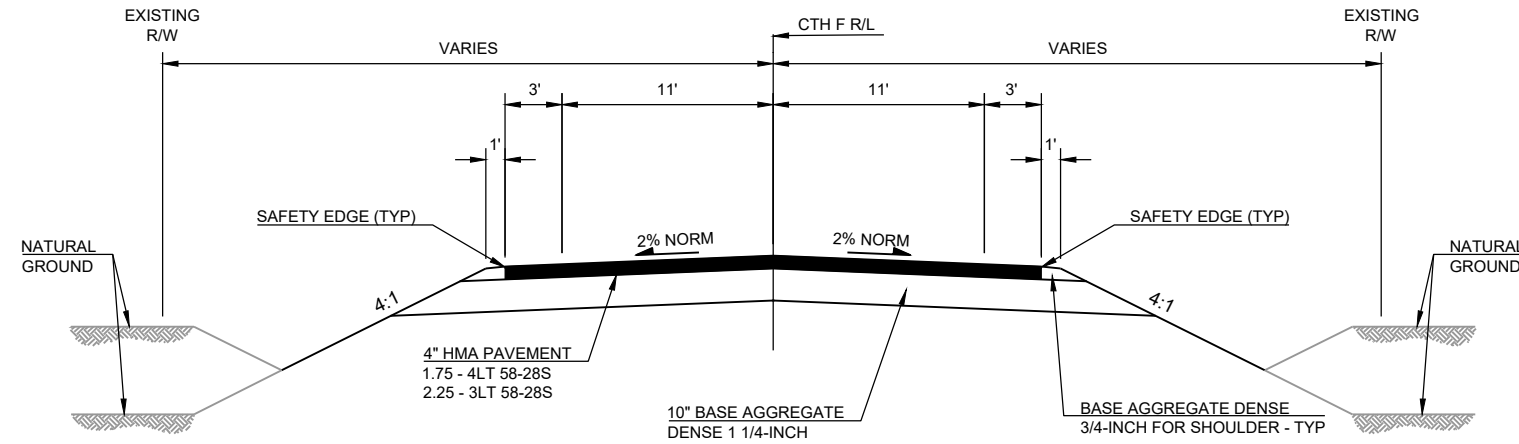

**FINISHED TYPICAL SECTION FOR CTH F**  
 STA 327+71.8 - STA 329+50

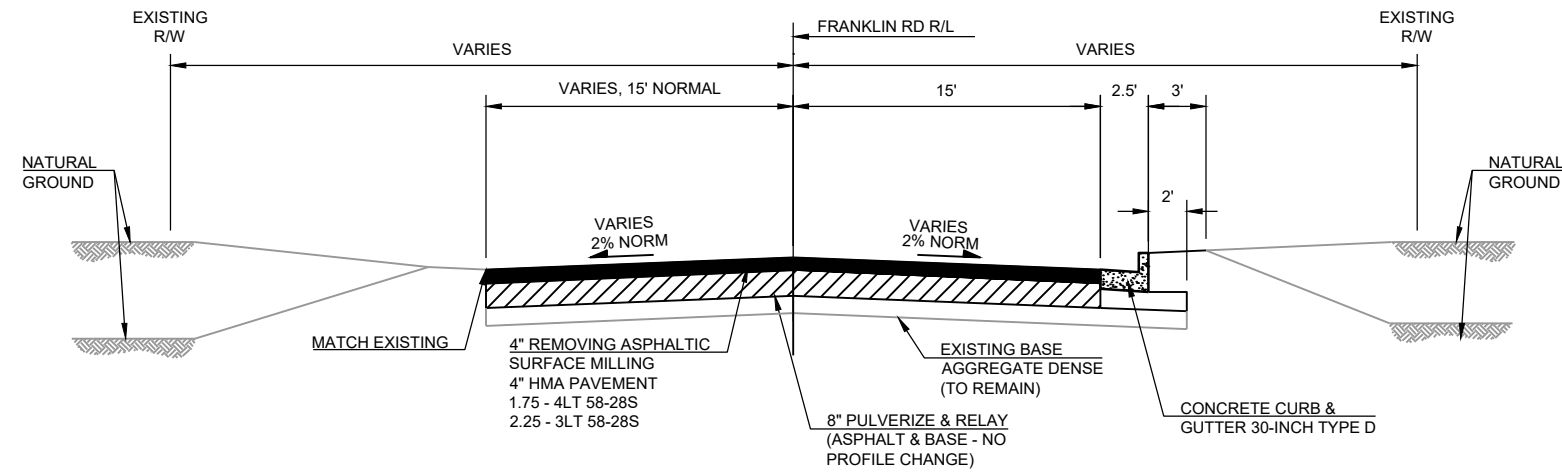

**FINISHED TYPICAL SECTION FOR FRANKLIN RD**  
 STA 401+60 - STA 402+89.22

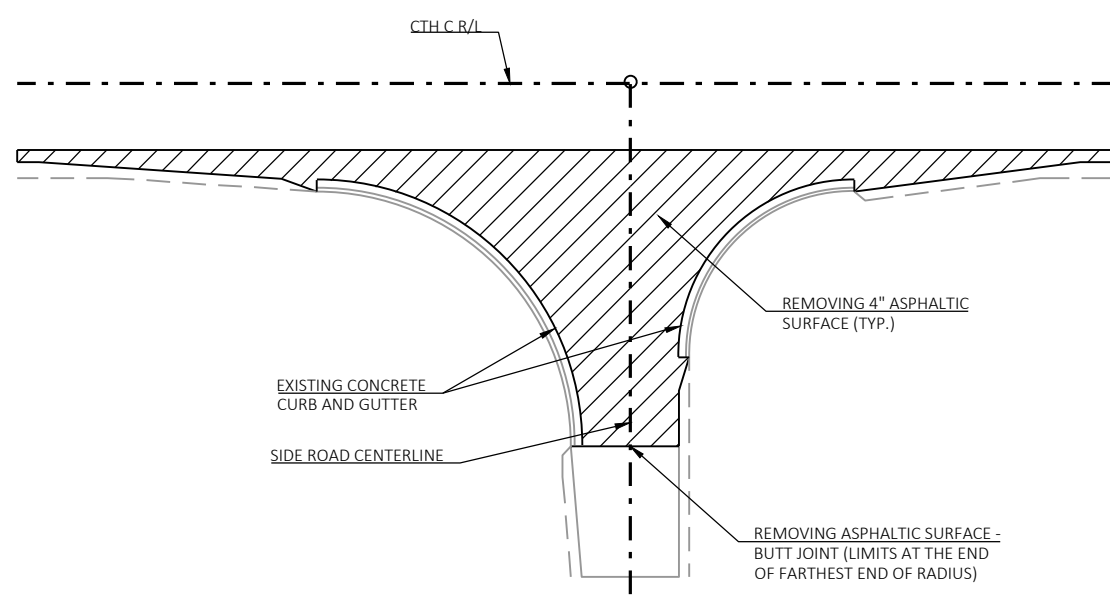

**SIDE ROAD CONSTRUCTION LIMITS**  
INTERSECTION WITH CONCRETE CURB AND GUTTER

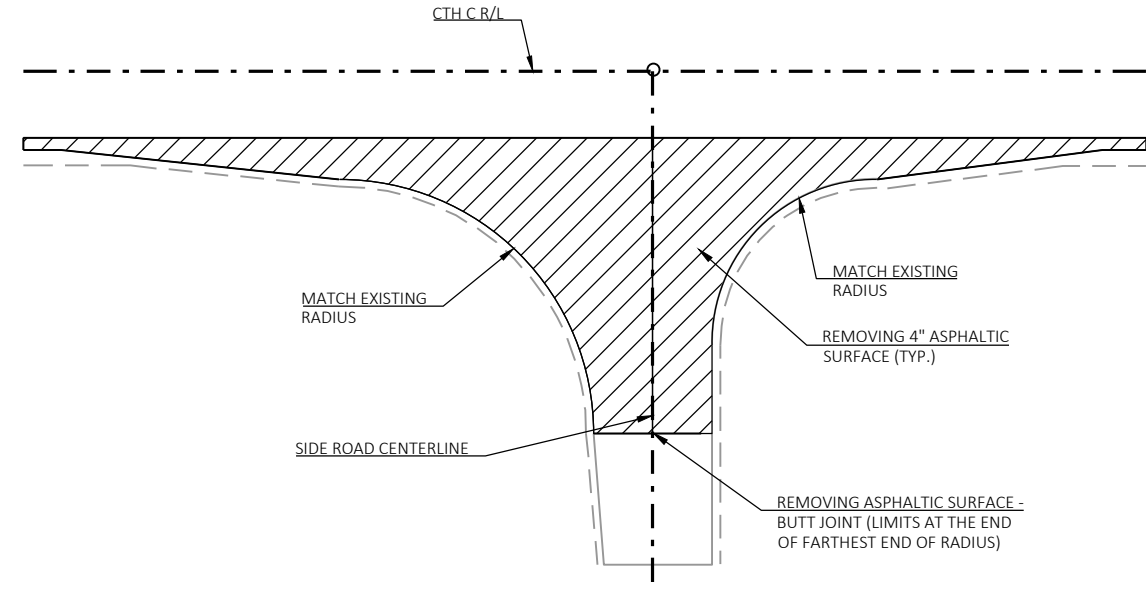

**SIDE ROAD CONSTRUCTION LIMITS**  
INTERSECTION WITHOUT CONCRETE CURB AND GUTTER

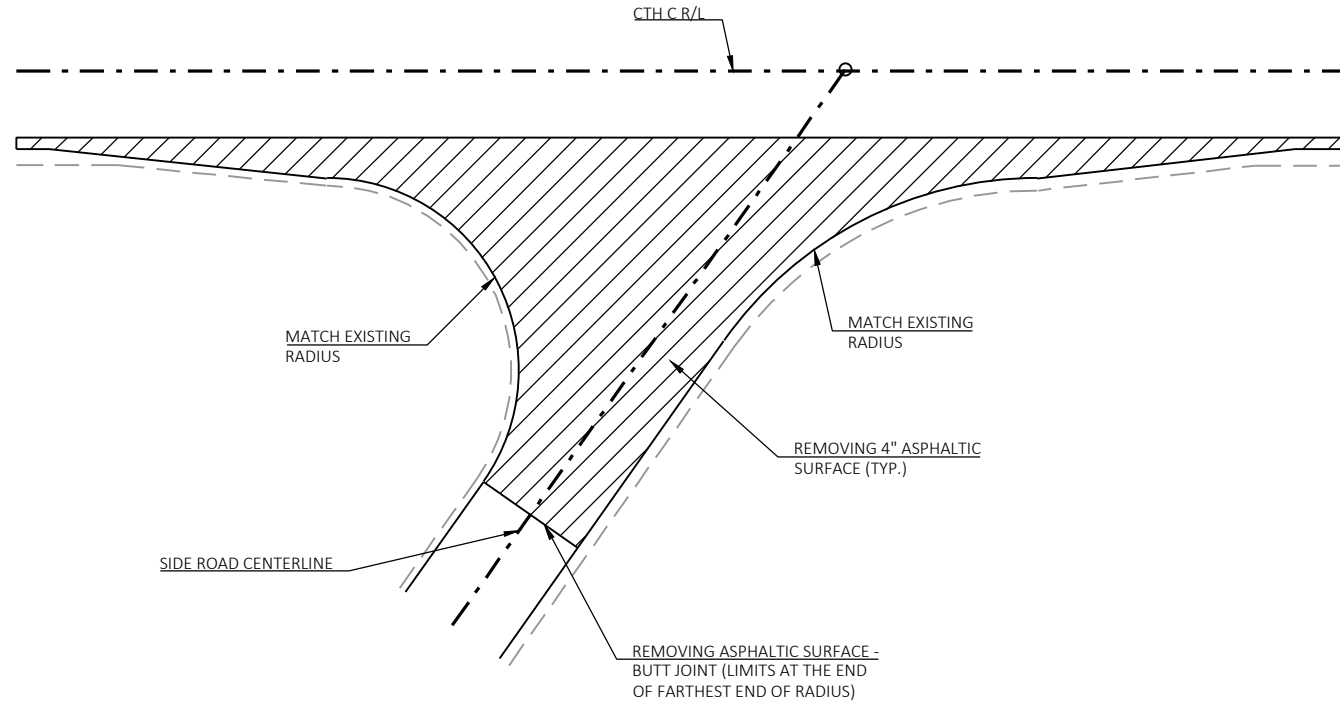

**SIDE ROAD CONSTRUCTION LIMITS**  
SKEWED SIDE ROAD LOCATIONS



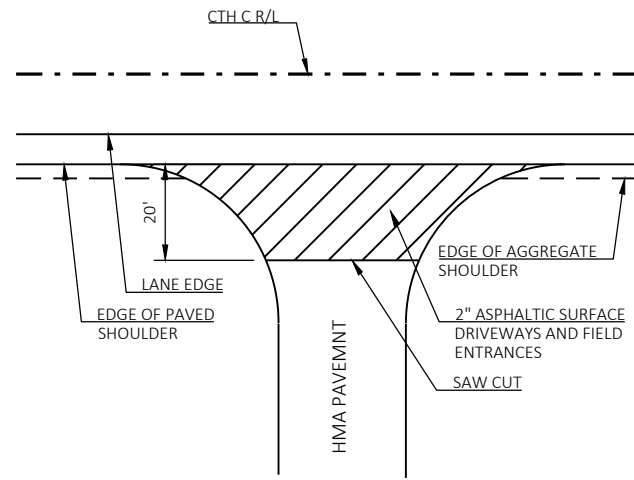

PRIVATE ENTRANCE HMA DETAIL - PROFILE CHANGE

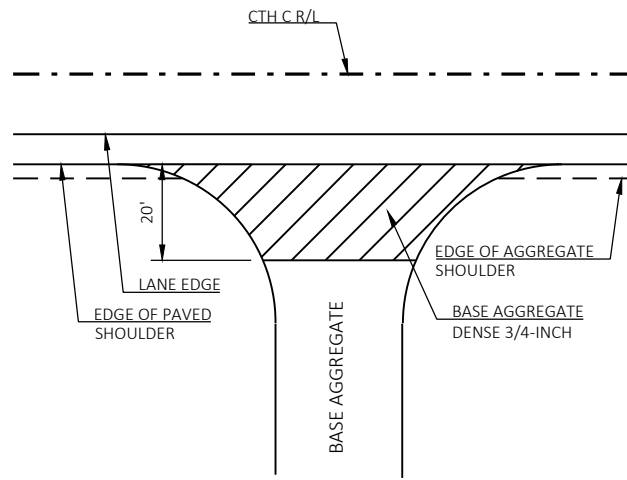

PRIVATE ENTRANCE BASE AGGREGATE DETAIL - PROFILE CHANGE

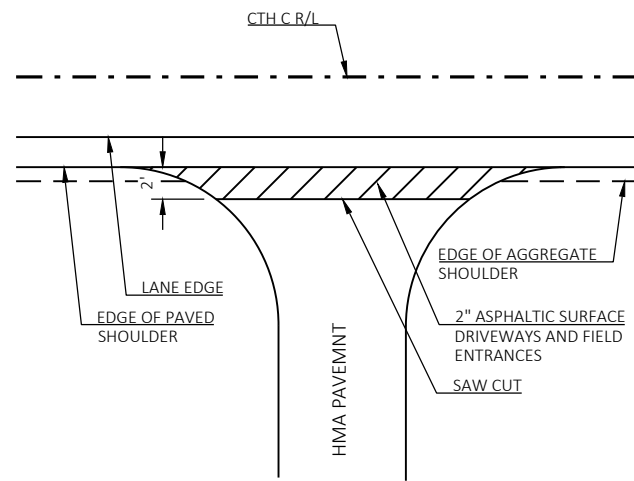
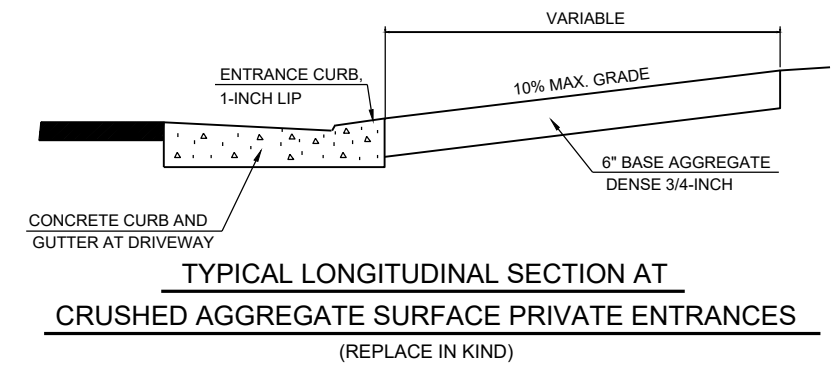



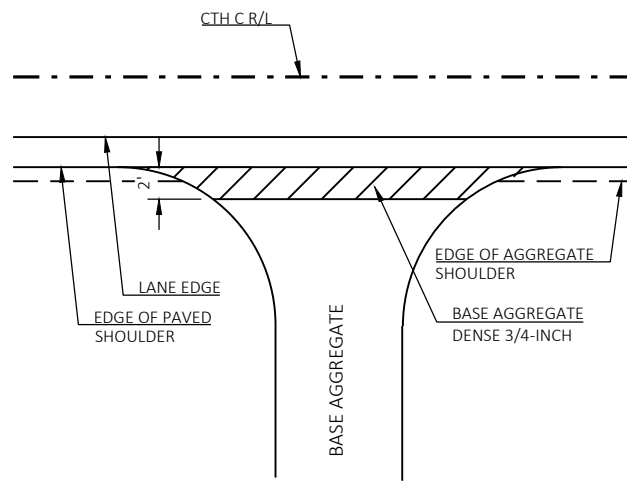

PRIVATE ENTRANCE HMA DETAIL - NO PROFILE CHANGE

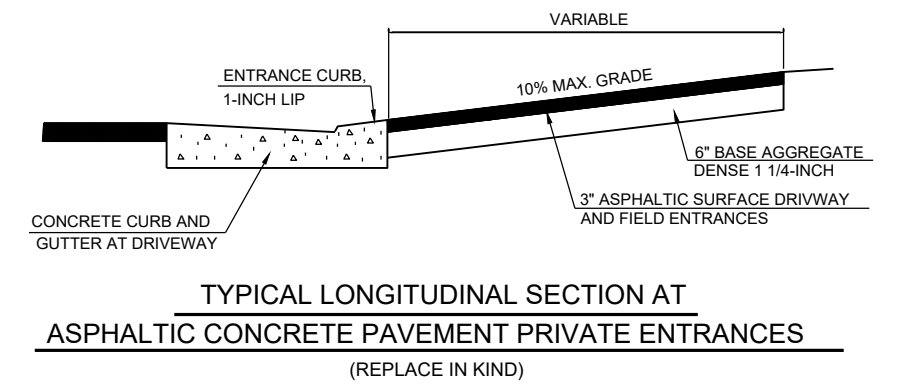

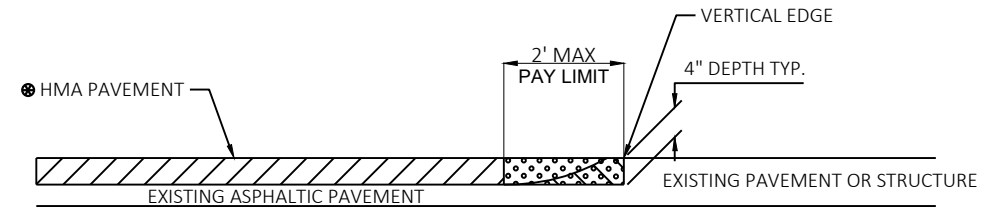
PRIVATE ENTRANCE BASE AGGREGATE DETAIL - NO PROFILE CHANGE





-  REMOVING ASPHALTIC SURFACE, MILLING
-  REMOVING ASPHALTIC SURFACE, BUTT JOINTS
-  REMOVE ASPHALTIC SURFACE WEDGE AT BUTT JOINT TO CREATE VERTICAL EDGE

SEE TYPICAL CROSS SECTION FOR PAVEMENT TYPE AND THICKNESS OF INDIVIDUAL LAYERS

BUTT JOINT DETAIL FOR ASPHALTIC PAVEMENTS AT SIDE ROADS (NO PROFILE CHANGE)

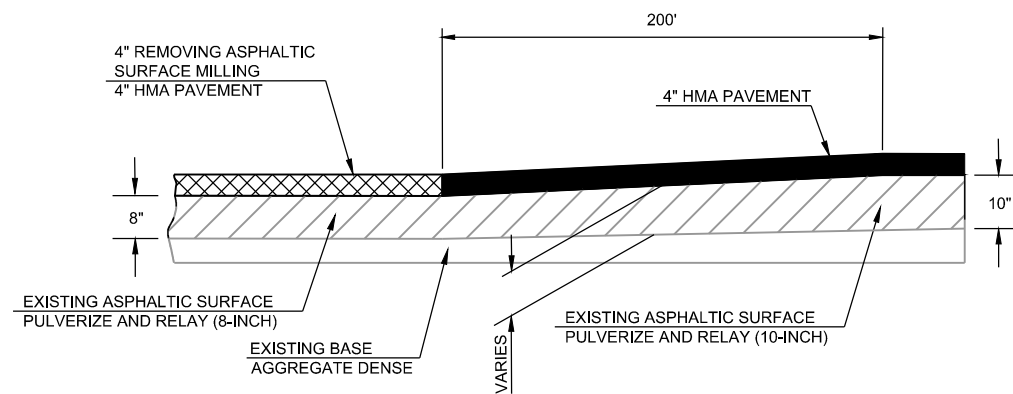

PULVERIZING TRANSITION DETAIL

STA. 214+00 TO STA. 216+00  
 STA. 234+00 TO STA. 236+00  
 STA. 243+50 TO STA. 245+50  
 STA. 266+25 TO STA. 268+25

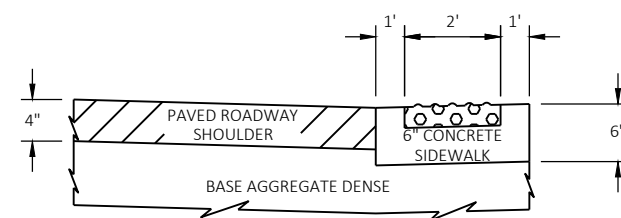
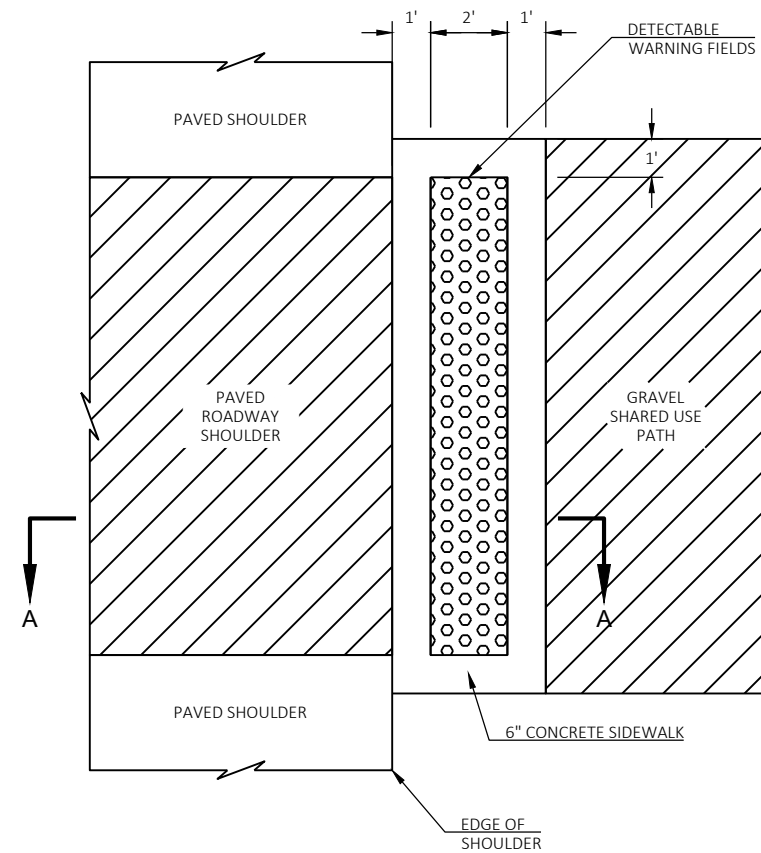

SECTION A-A

DETECTABLE WARNING FIELD INSTALLATION FOR SHARED-USED PATH CROSSING A NON-CURBED ROADWAY

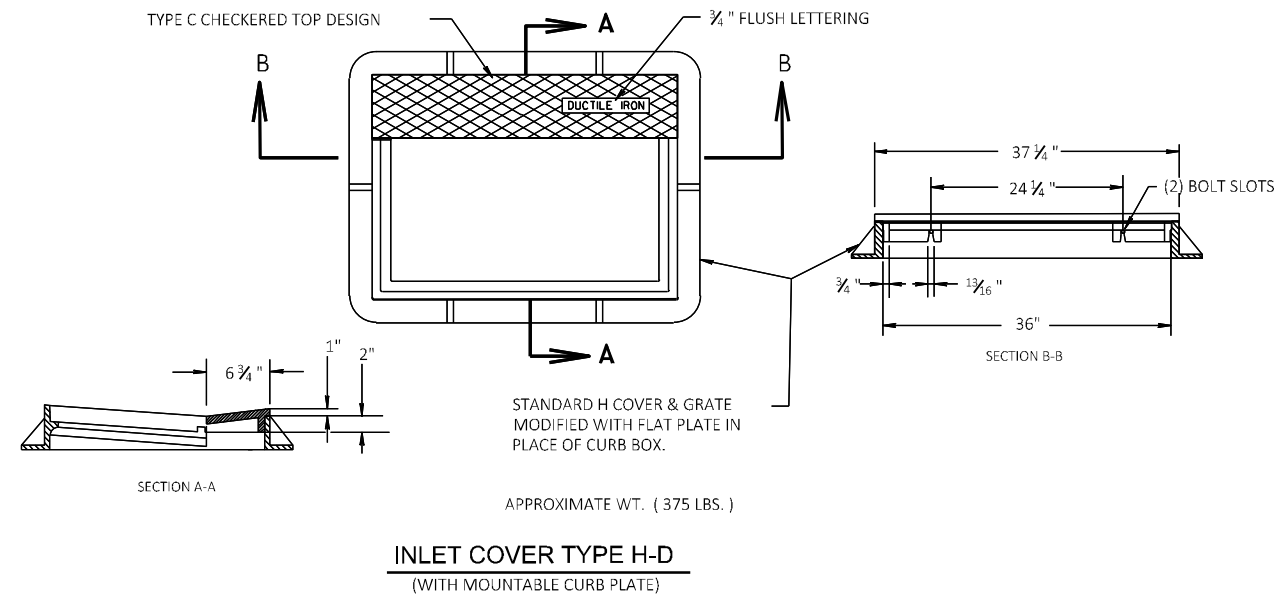
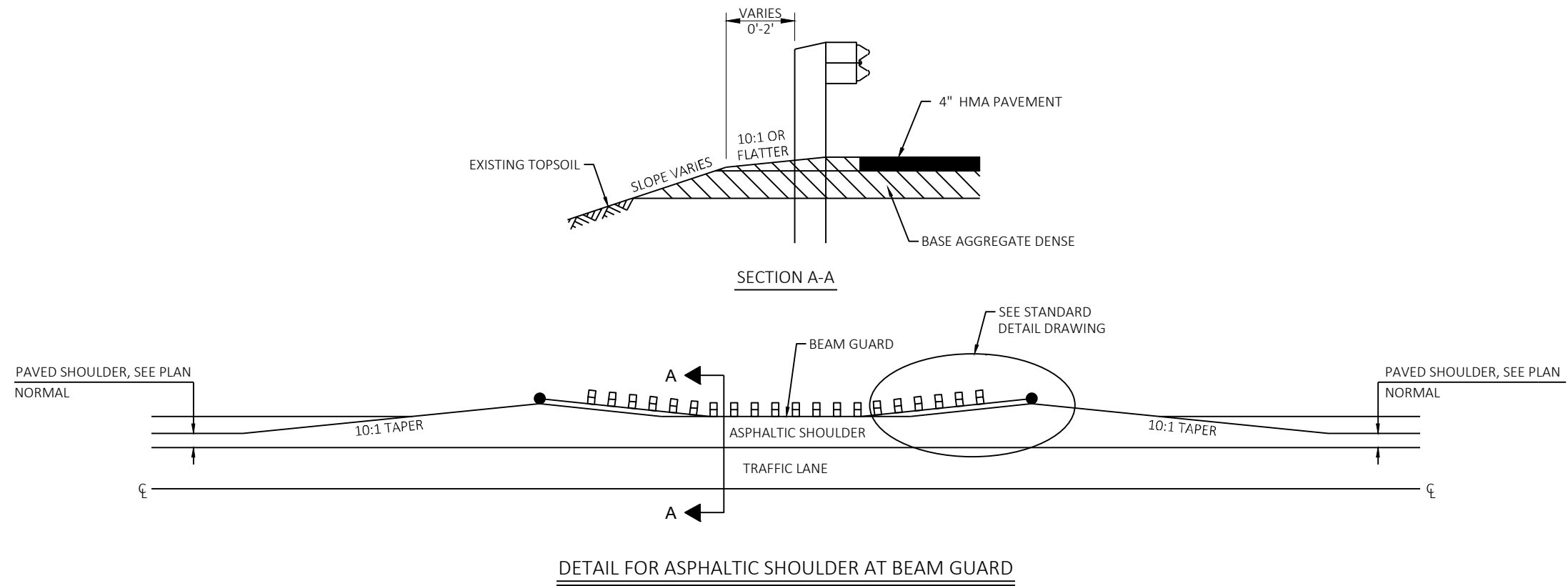

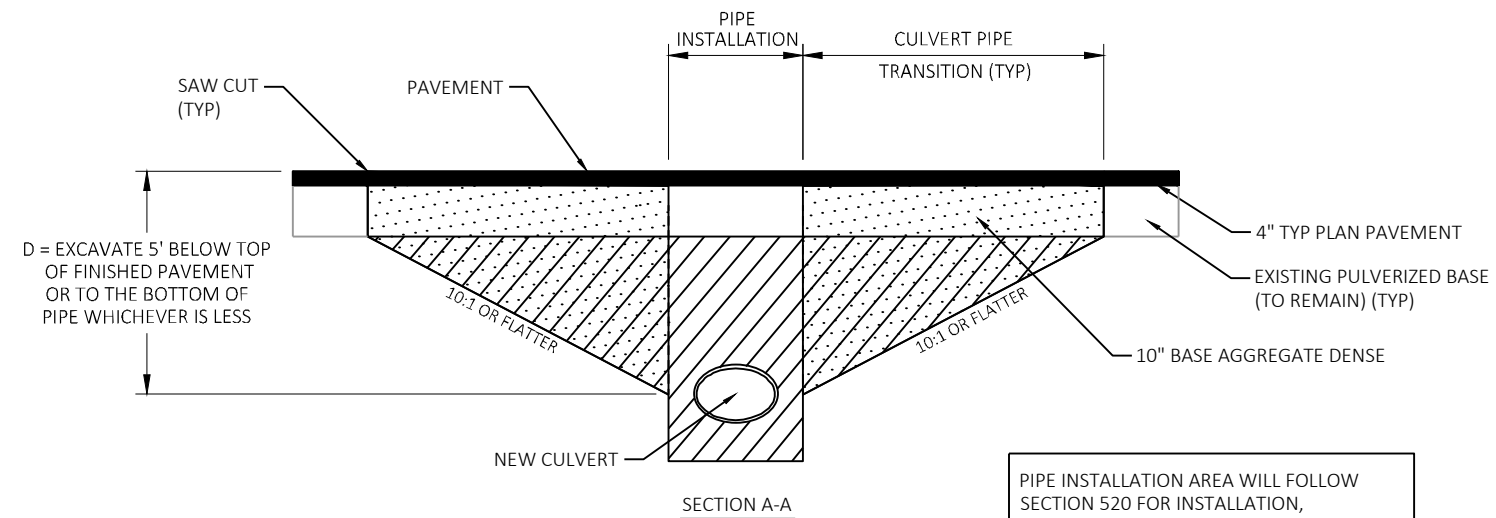
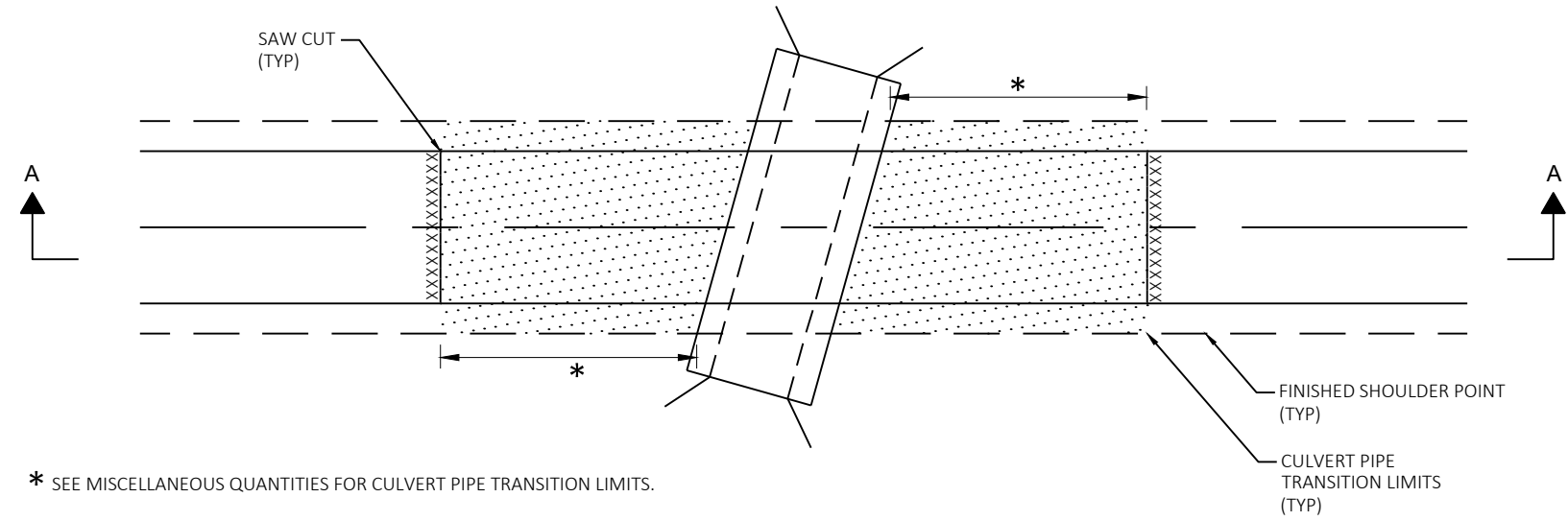

COMMON EXCAVATION

FOUNDATION BACKFILL

PIPE INSTALLATION AREA WILL FOLLOW SECTION 520 FOR INSTALLATION, WIDTHS AND PAYMENT.

CONSTRUCT TRANSITION PERPENDICULAR TO CULVERT PIPE.

CULVERT PIPE TRANSITION AREAS WILL BE PAID BY COMMON EXCAVATION & SPV FOUNDATION BACKFILL.

PAVEMENT SAW CUT TO BE PERPENDICULAR TO ROADWAY ALIGNMENT.

NEW CULVERT PIPES WITH TRANSITION



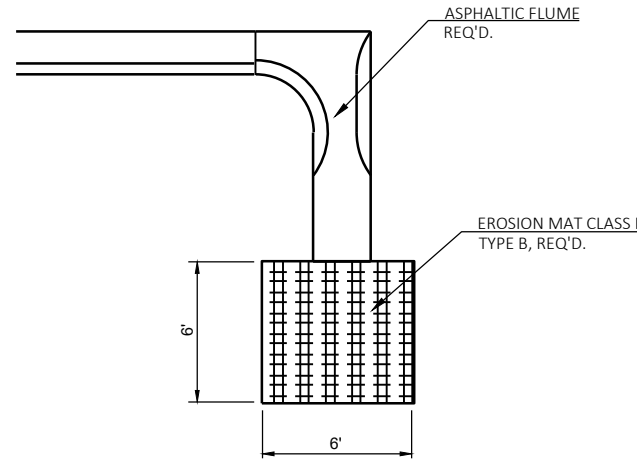

EROSION MAT AT ASPHALTIC FLUME

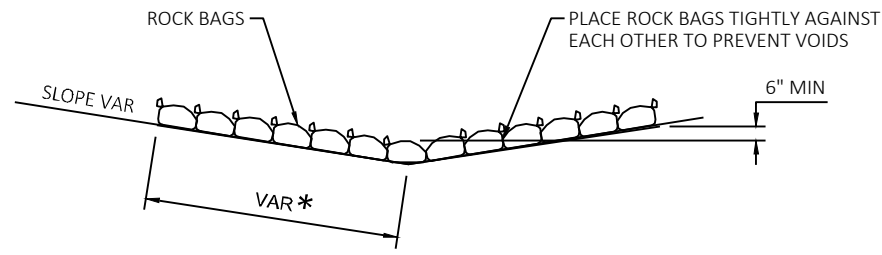

SIDE VIEW (SINGLE LAYER)

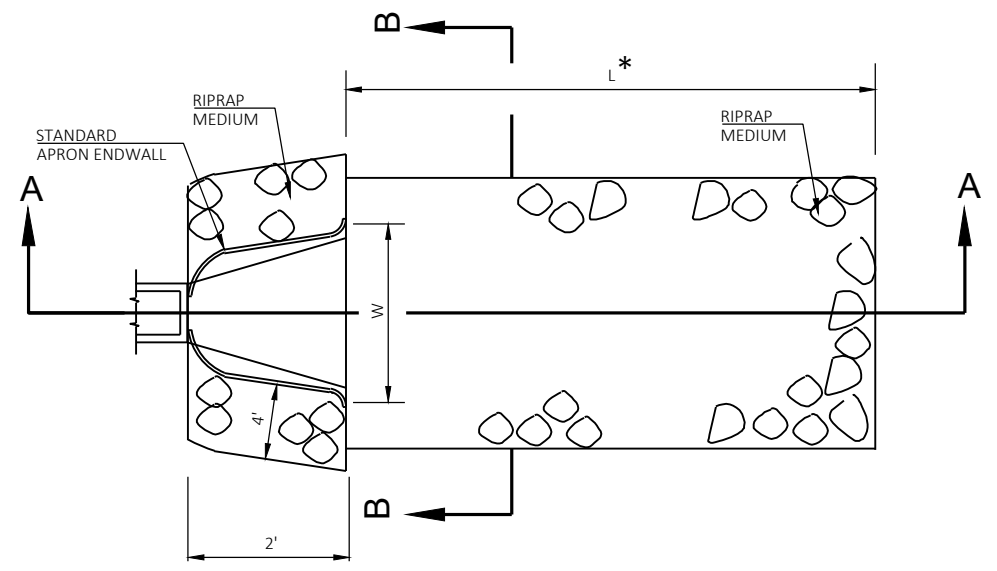

\*L = 3 TIMES DIAMETER (NORMAL) OR MINIMUM 6' OR AS DIRECTED BY THE ENGINEER

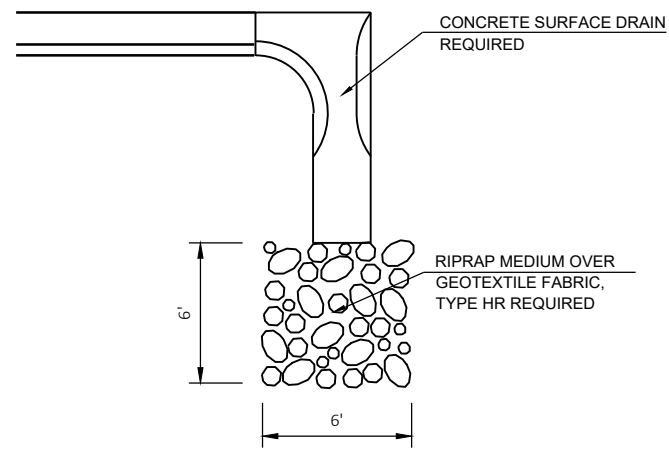

RIPRAP MEDIUM AT CONCRETE SURFACE DRAIN

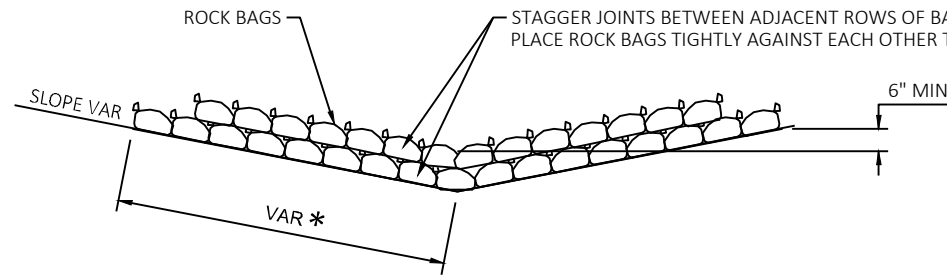

SIDE VIEW (MULTIPLE LAYER)

ROCK BAGS DITCH CHECK

PAID AS ROCK BAGS

\* LENGTH AND NUMBER OF BAGS MAY VARY DEPENDING ON DESIRED DEPTH OF WATER POOL

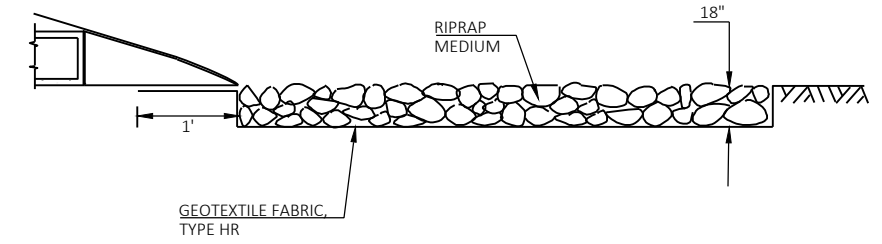

SECTION A-A

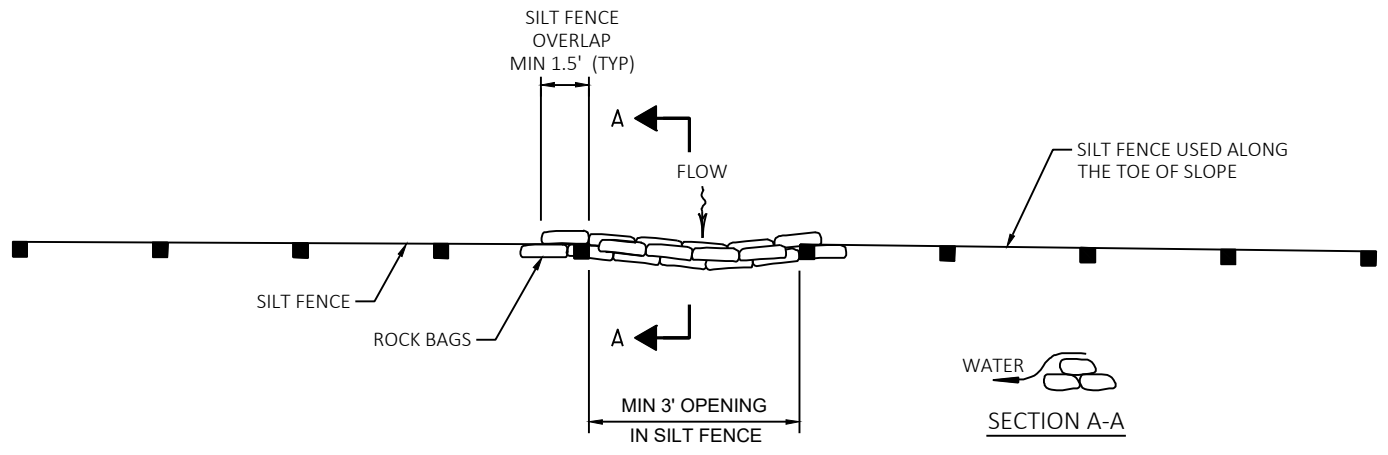

TOP VIEW

ROCK BAGS USED FOR SILT FENCE RELIEF DETAIL

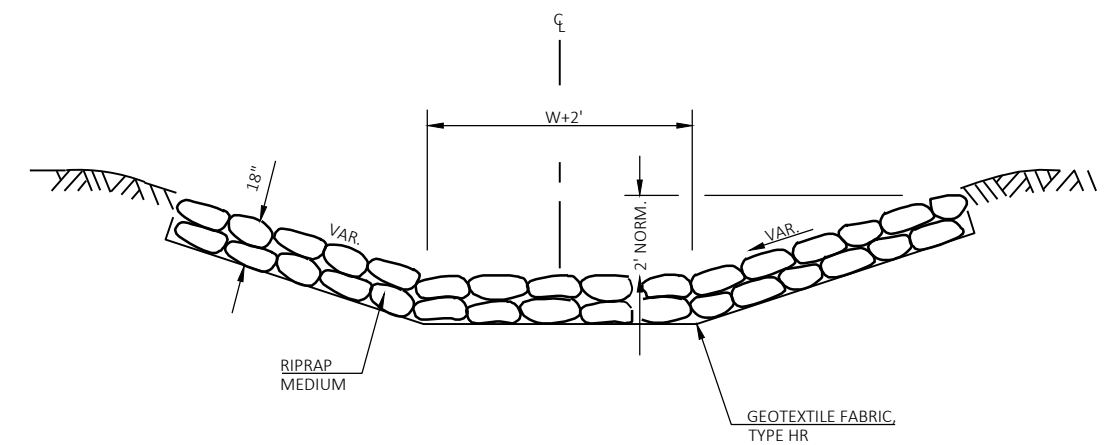

SECTION B-B

RIPRAP MEDIUM AND GEOTEXTILE FABRIC DETAIL AT APRON ENDWALLS

(SEE MISCELLANEOUS QUANTITIES FOR LOCATIONS)

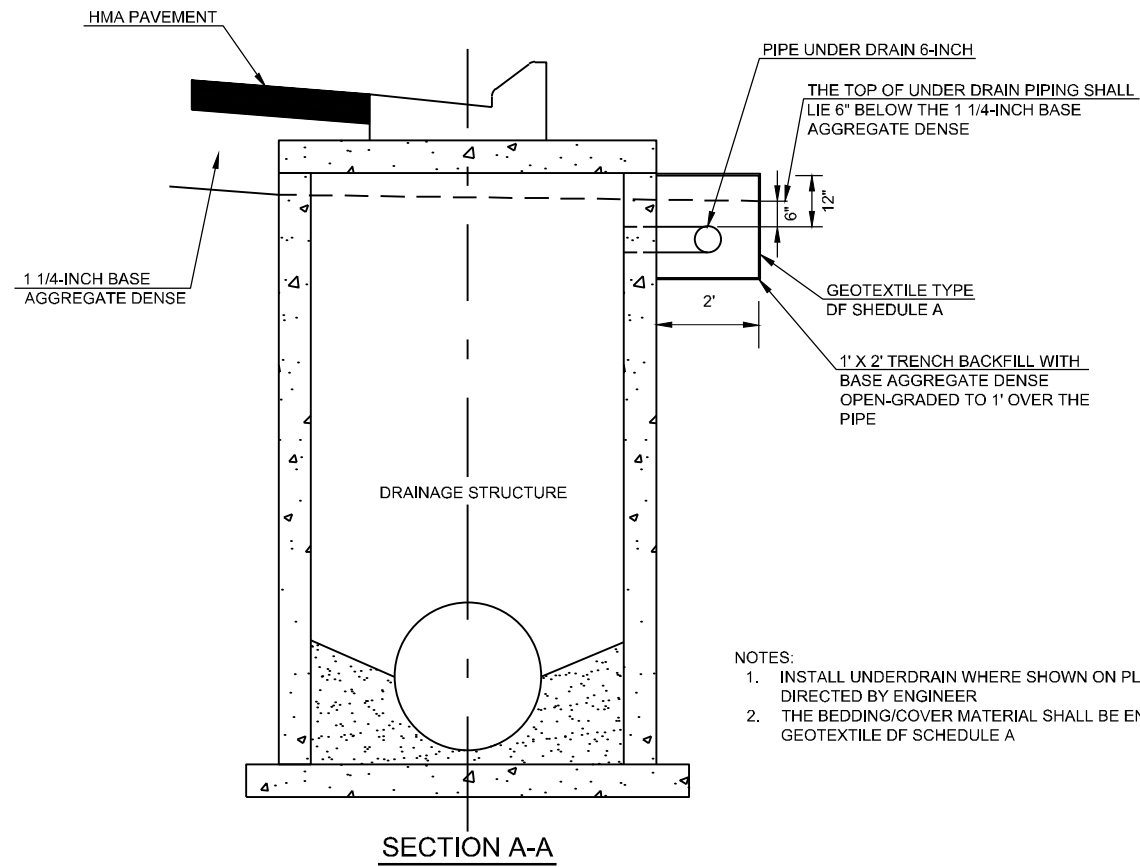

- NOTES:
1. INSTALL UNDERDRAIN WHERE SHOWN ON PLANS AND/OR AS DIRECTED BY ENGINEER
  2. THE BEDDING/COVER MATERIAL SHALL BE ENCASED WITH GEOTEXTILE DF SCHEDULE A

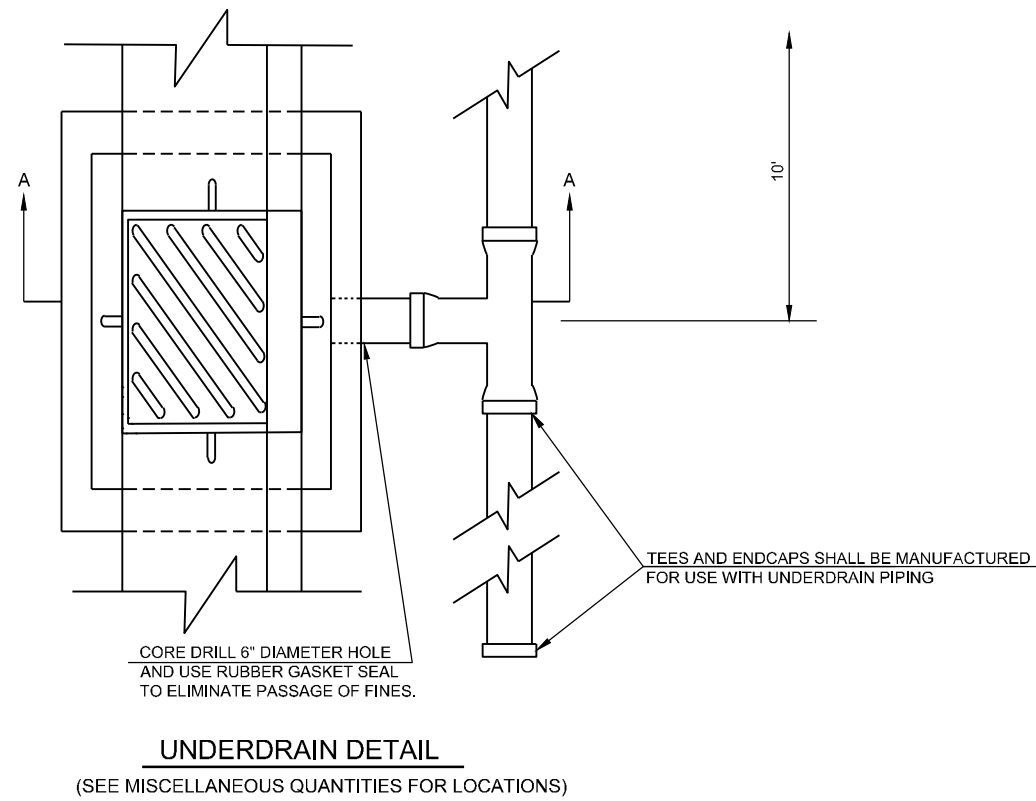

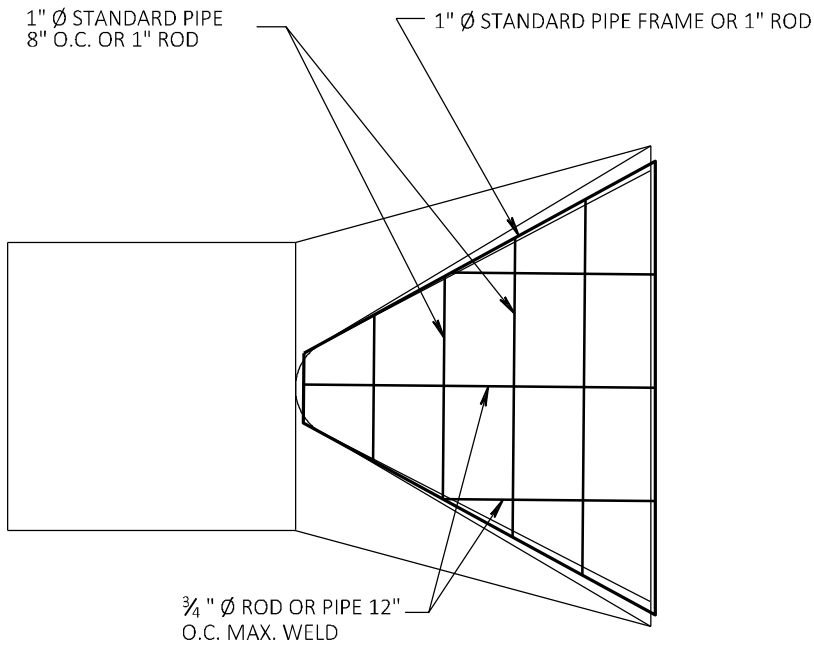
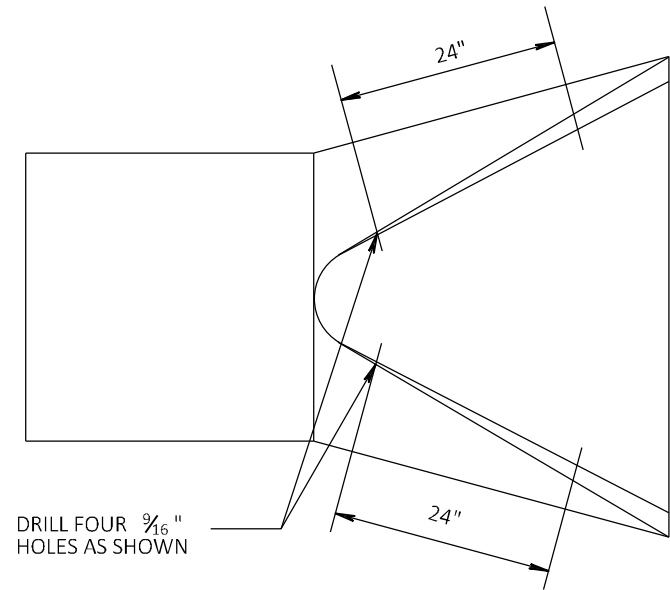

AT EACH PIPE

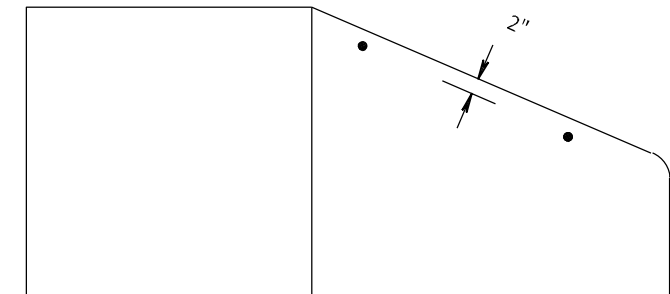
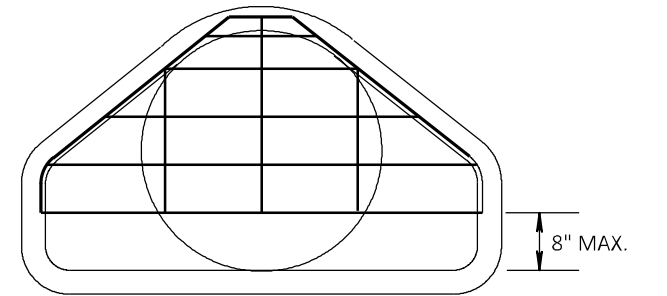

BOLT GRATE TO CONCRETE ENDWALL  
WITH FOUR  $\frac{3}{8}$ " X 6" MACHINE BOLTS  
PLACE NUTS INSIDE

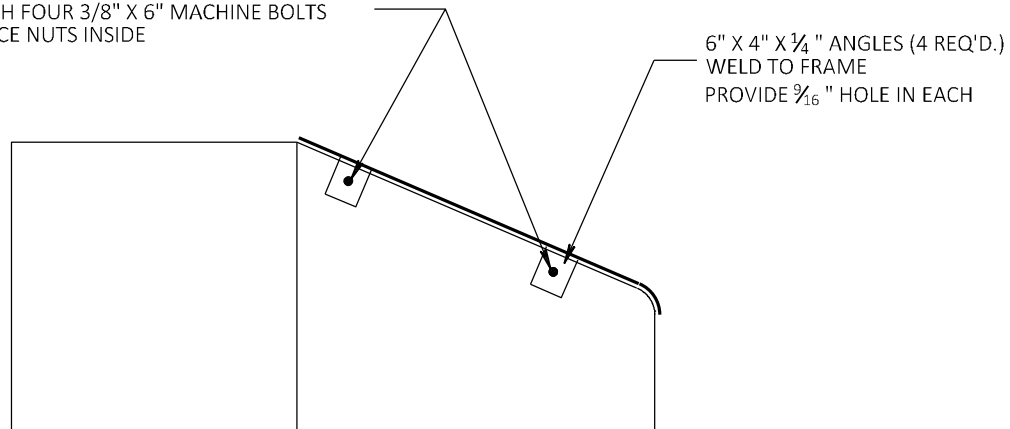

PIPE GRATE DETAIL

LEGEND

- XXXXXX SAW CUTS
- X TREE TO BE GRUBBED

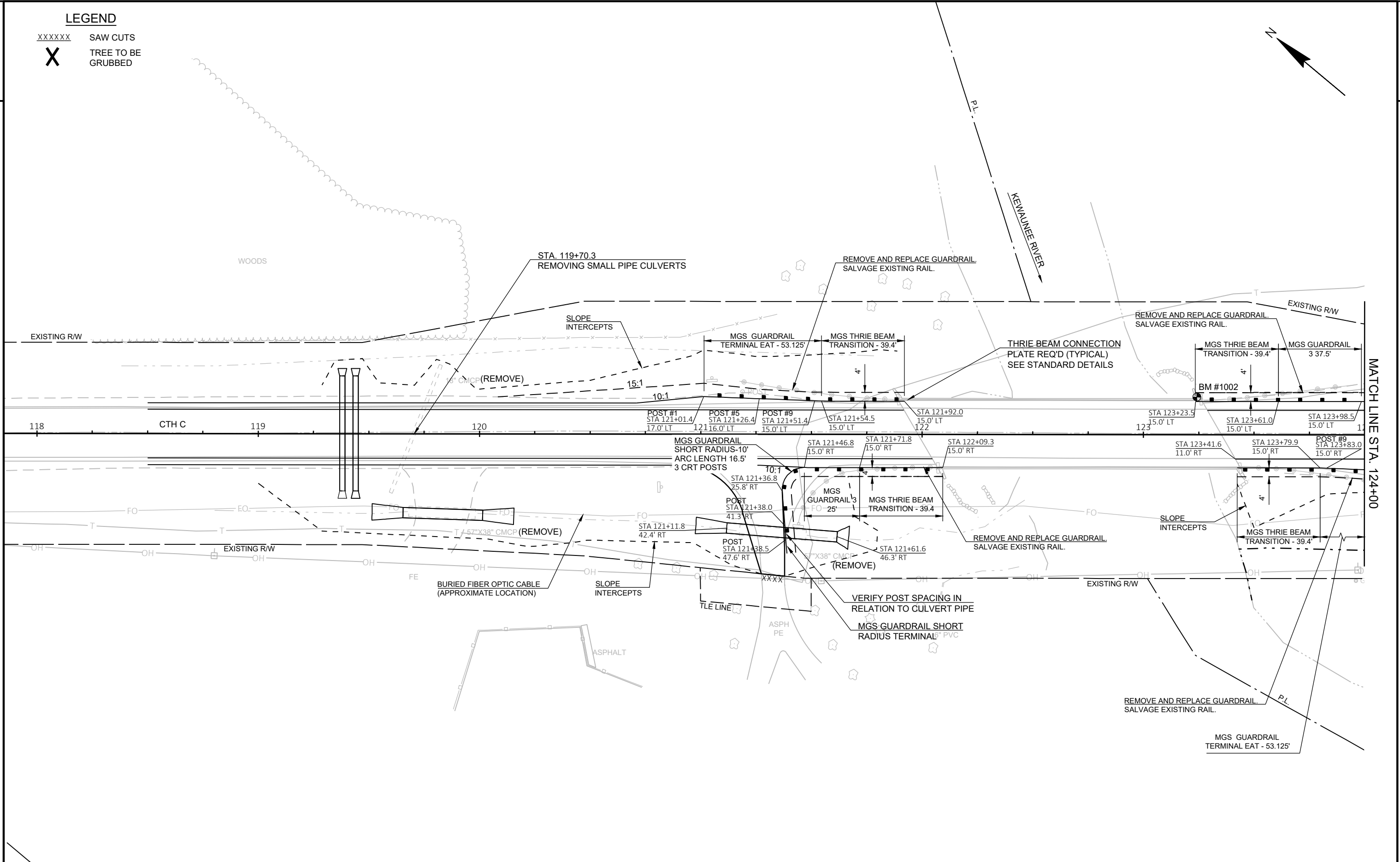
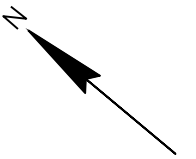

PROJECT NO: 4390-07-71	HWY: CTH C	COUNTY: KEWAUNEE	PLAN DETAILS
			SHEET <b>E</b>



LEGEND

- XXXXXX SAW CUTS
- X TREE TO BE GRUBBED

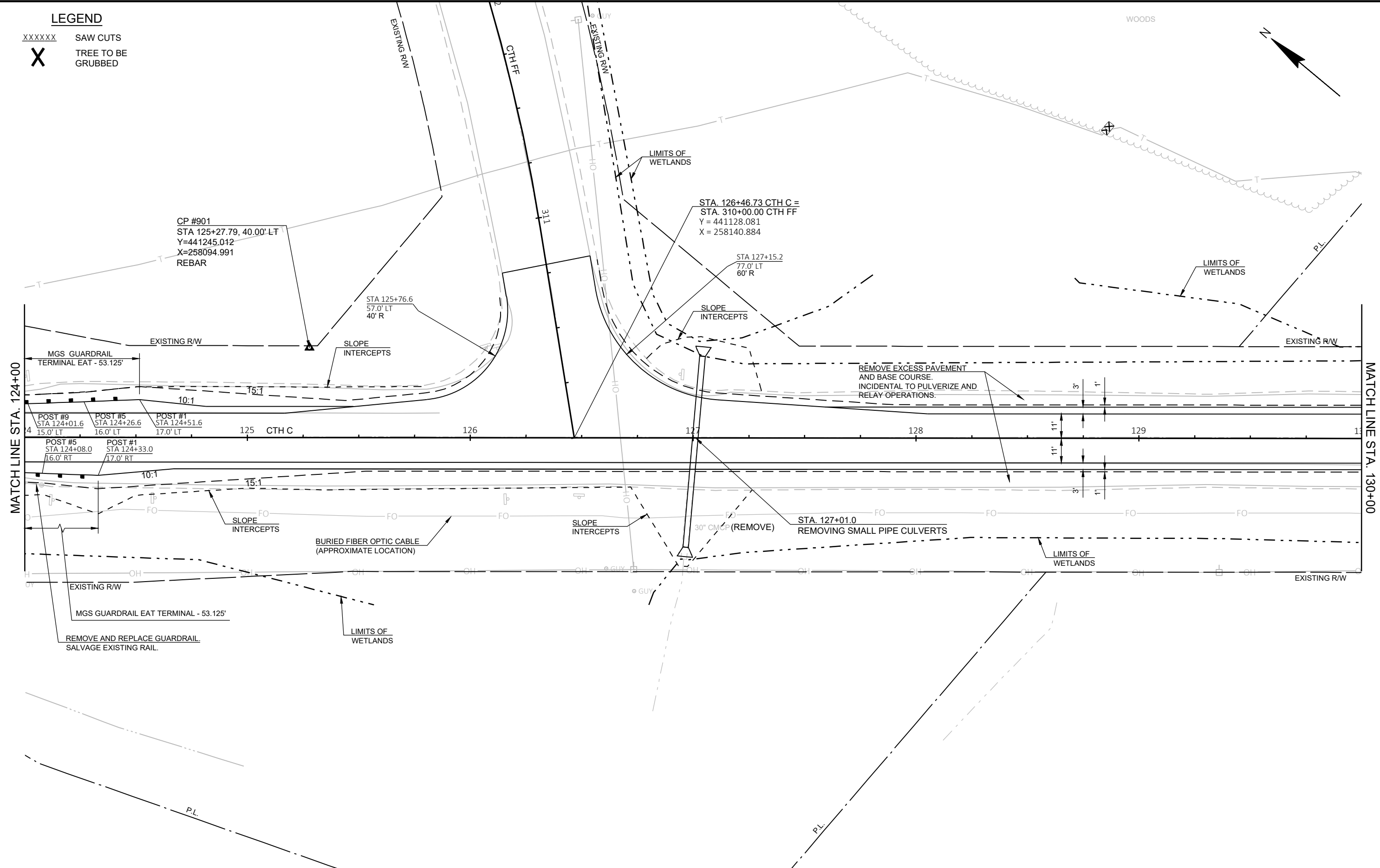

LEGEND

- XXXXXX SAW CUTS
- X TREE TO BE GRUBBED

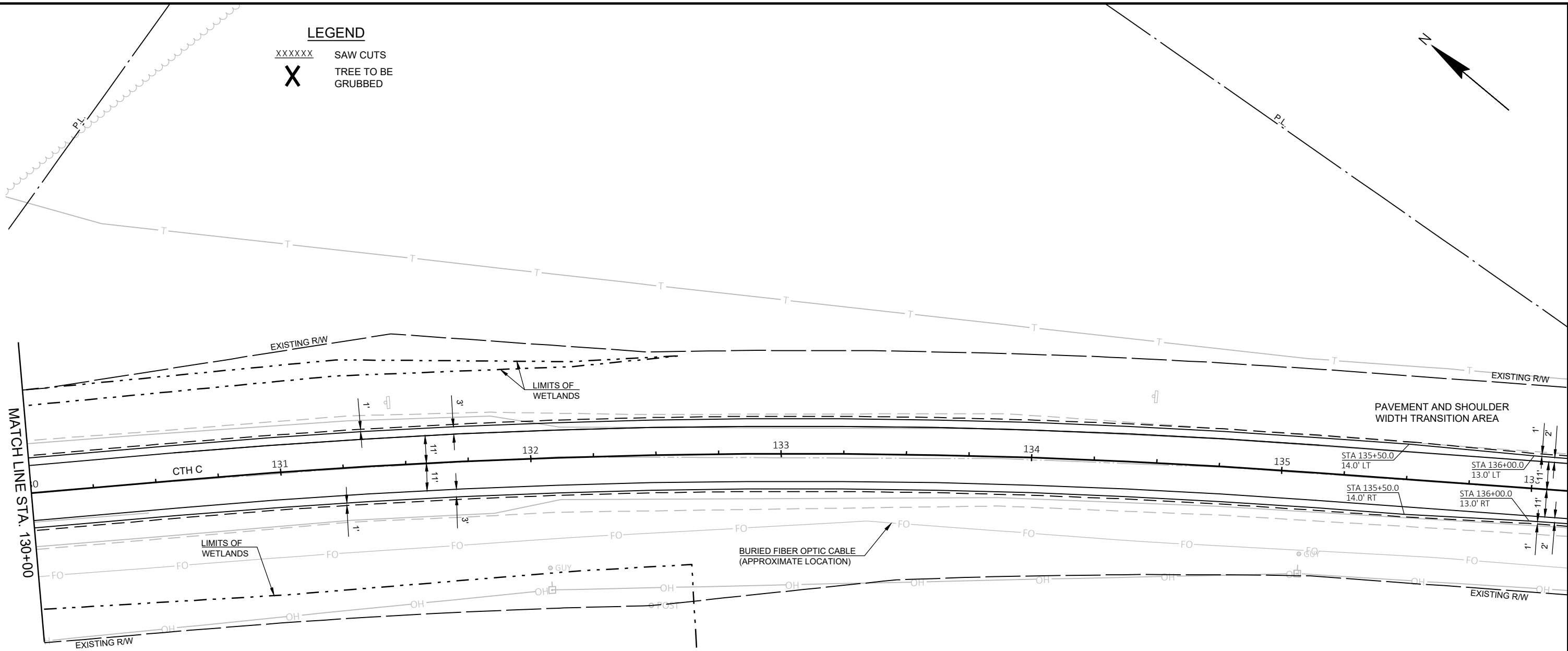
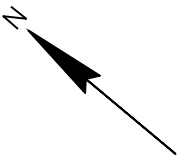

LEGEND

- XXXXXX SAW CUTS
- X TREE TO BE GRUBBED

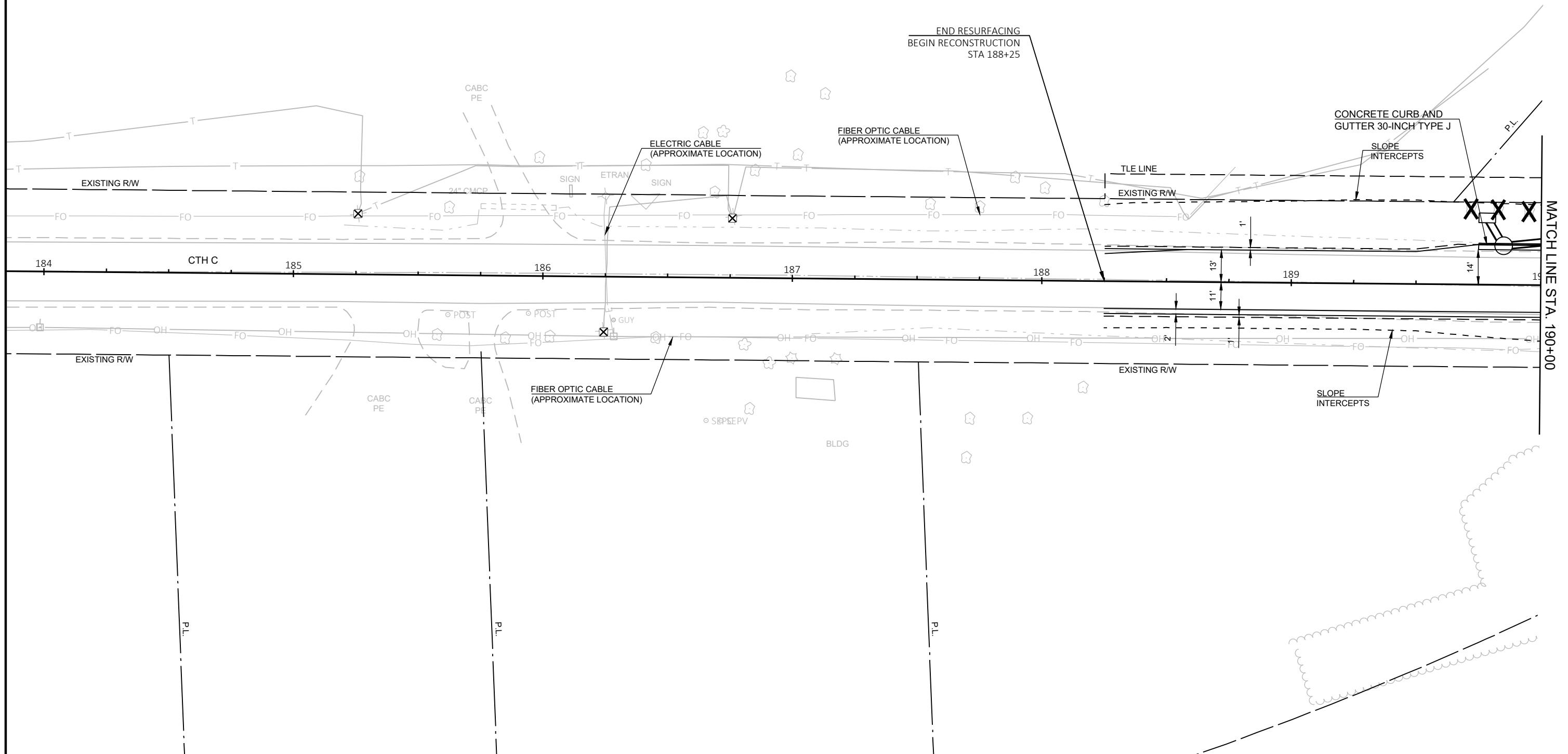
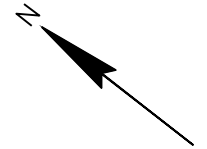

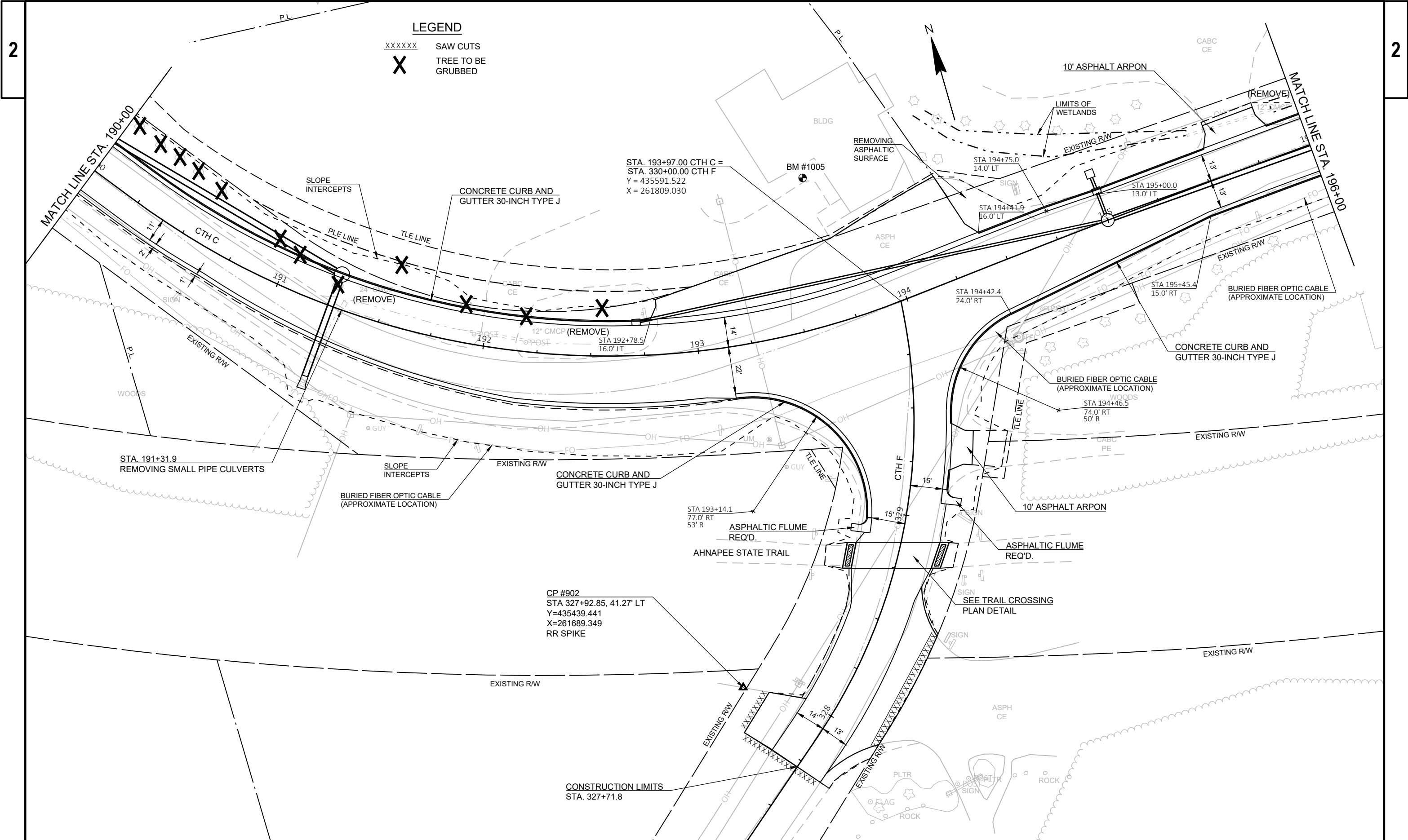

2

2

LEGEND

- XXXXXX SAW CUTS
- X TREE TO BE GRUBBED

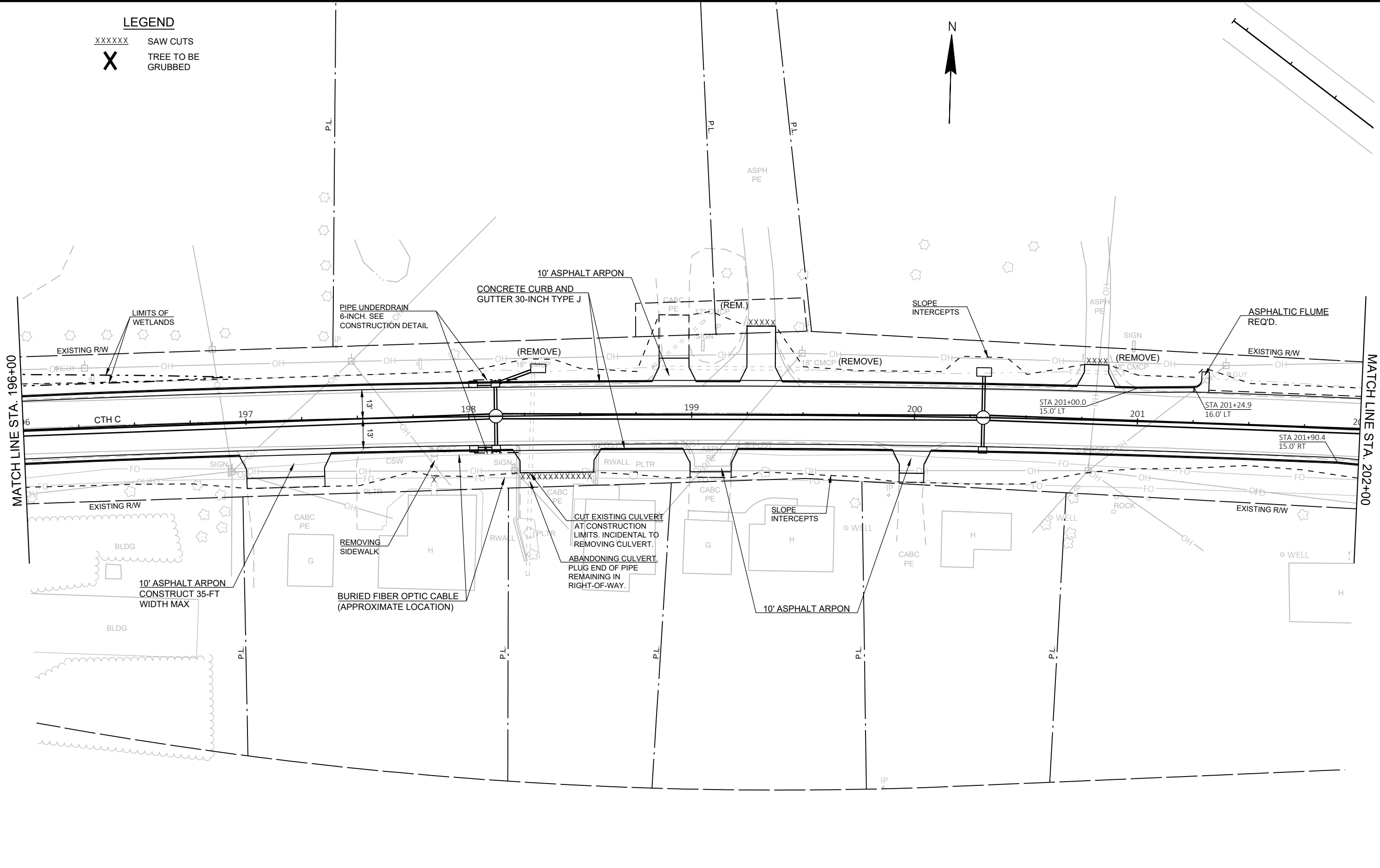

PROJECT NO: 4390-07-71

HWY: CTH C

COUNTY: KEWAUNEE

PLAN DETAILS

SHEET

E

LEGEND

- XXXXXX SAW CUTS
- X TREE TO BE GRUBBED

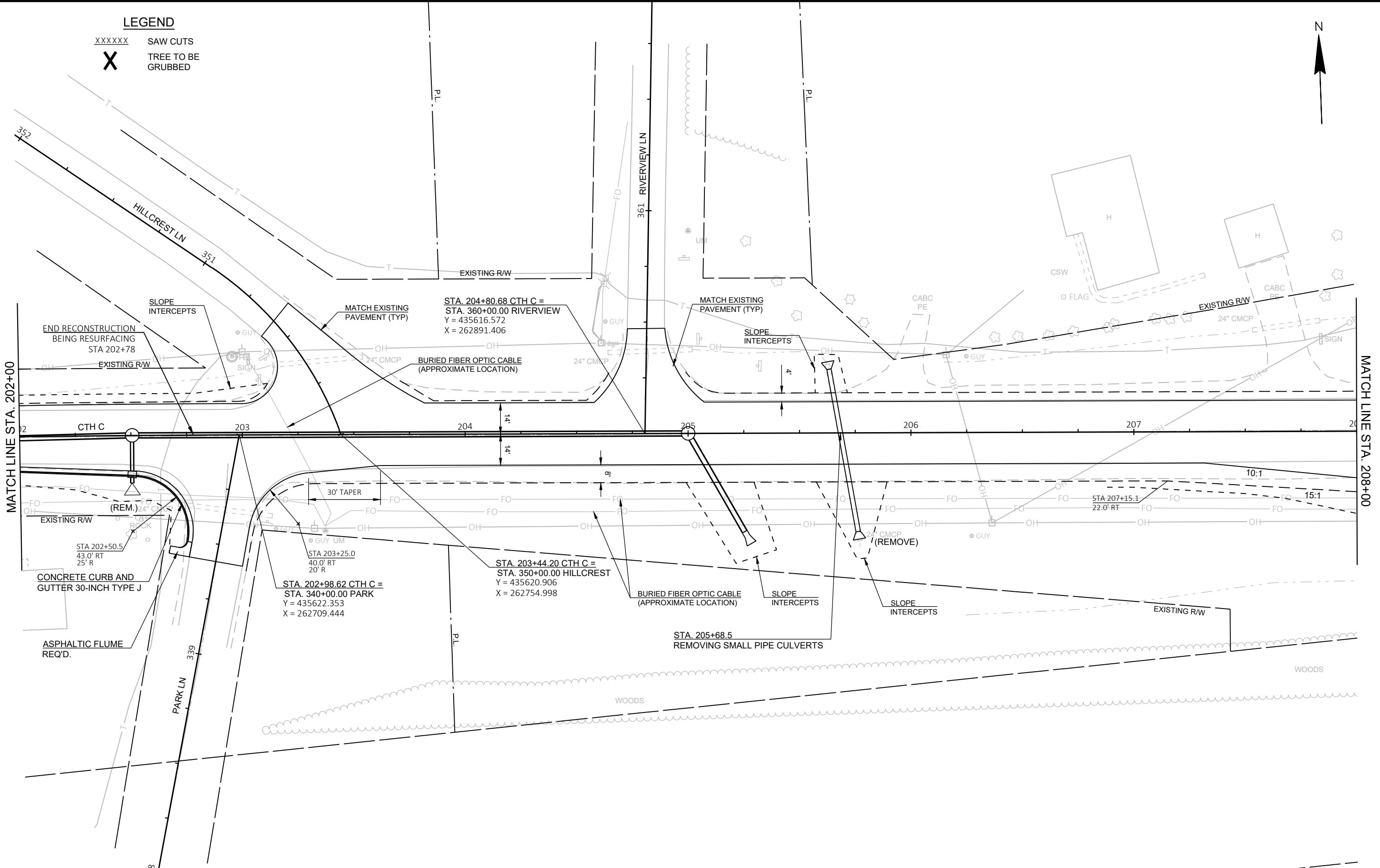

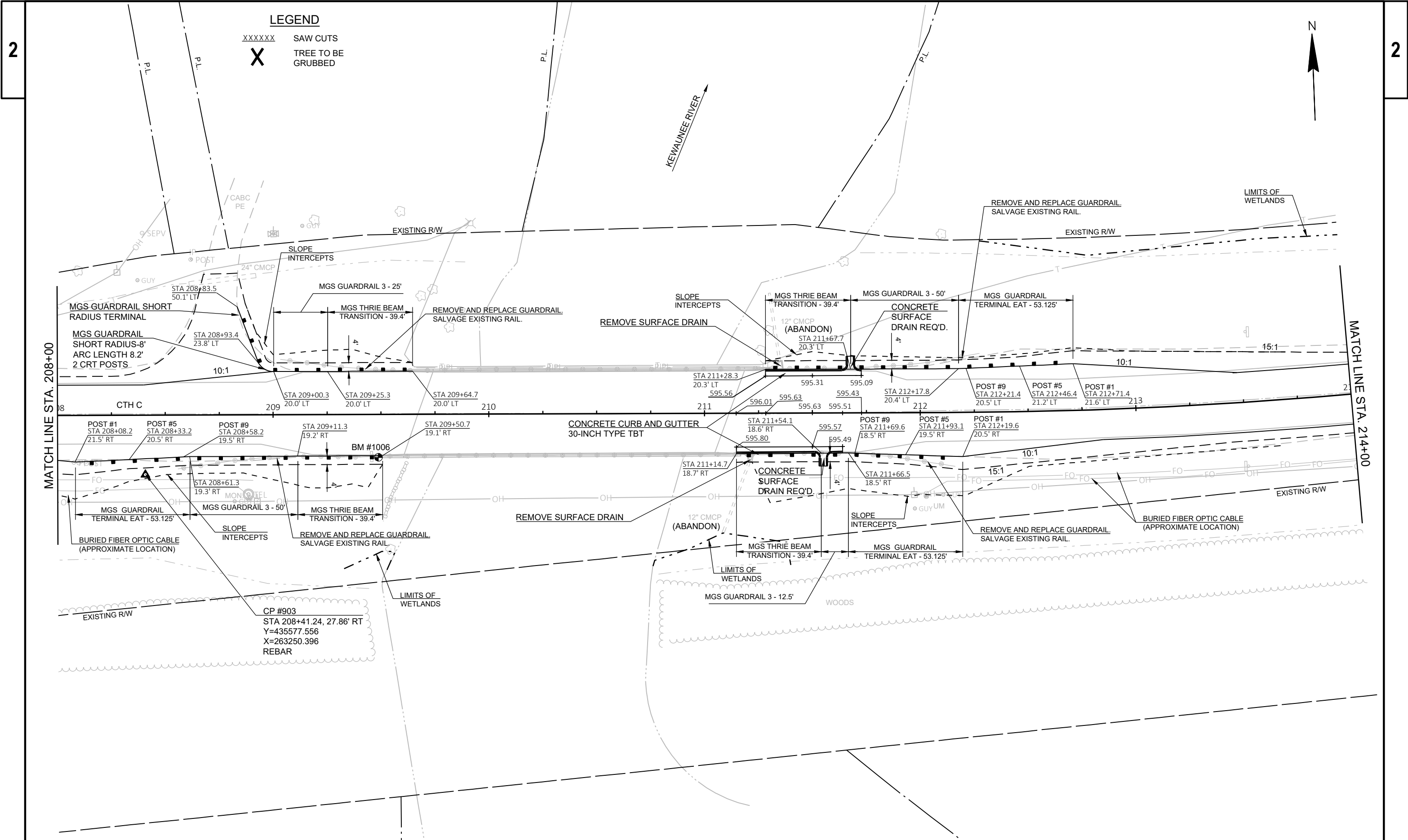

**LEGEND**  
 XXXXXX SAW CUTS  
 X TREE TO BE GRUBBED



MATCH LINE STA. 208+00

MATCH LINE STA. 214+00

LEGEND

- XXXXXX SAW CUTS
- X TREE TO BE GRUBBED

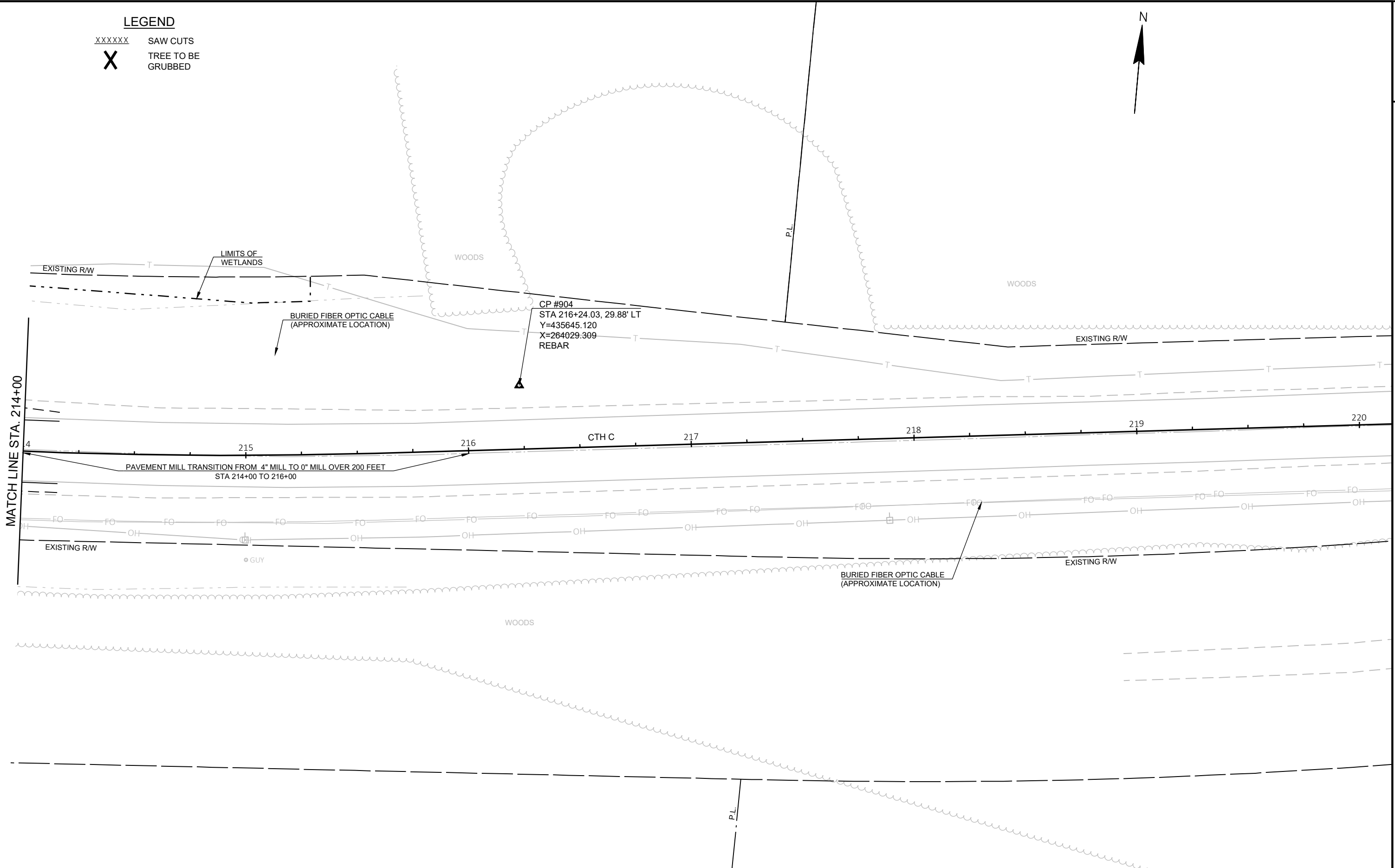

PROJECT NO: 4390-07-71	HWY: CTH C	COUNTY: KEWAUNEE	PLAN DETAILS	SHEET	<b>E</b>
------------------------	------------	------------------	--------------	-------	----------



LEGEND

- XXXXXX SAW CUTS
- X TREE TO BE GRUBBED

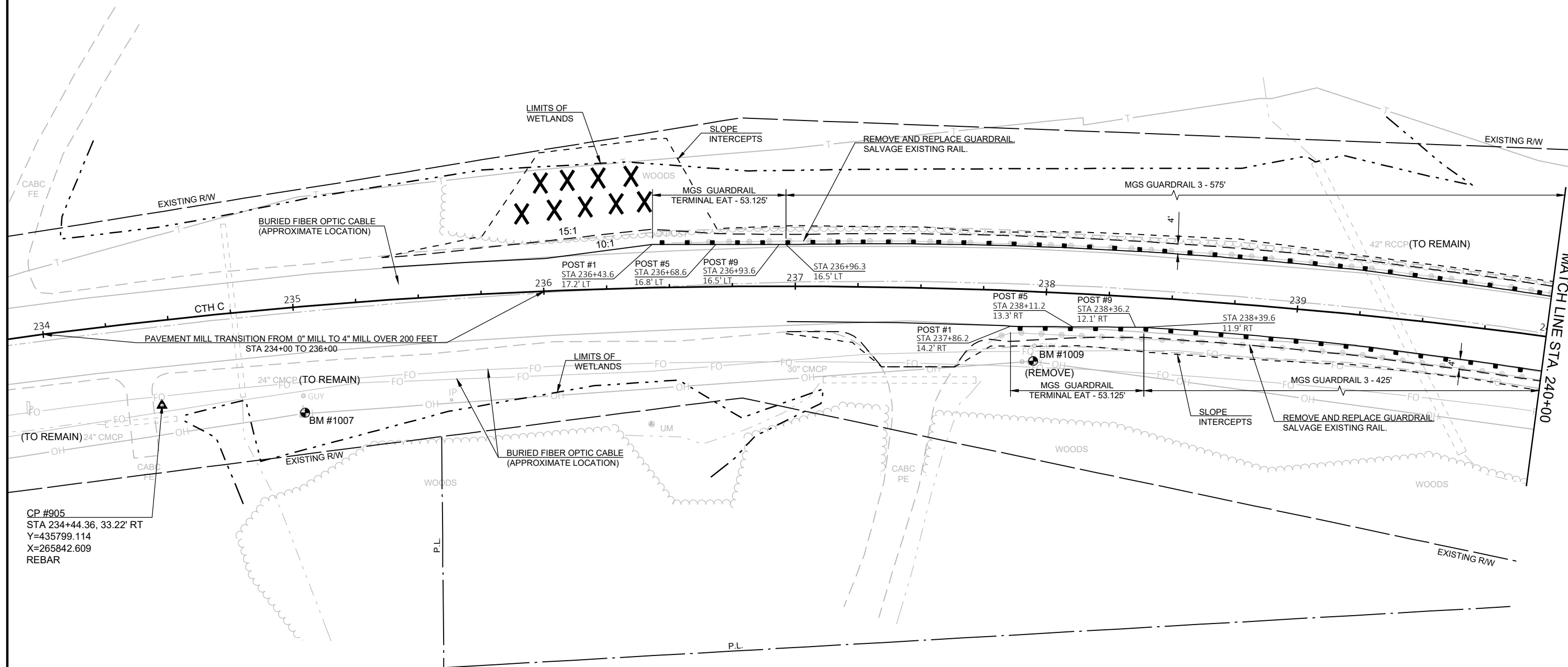

NOTE:  
 EXISTING ROADWAY CENTERLINE AND  
 REFERENCE LINE ARE NOT COINCIDENTAL.

GUARDRAIL OFFSETS SHOWN FROM  
 REFERENCE LINE.

LEGEND

- XXXXXX SAW CUTS
- X TREE TO BE GRUBBED

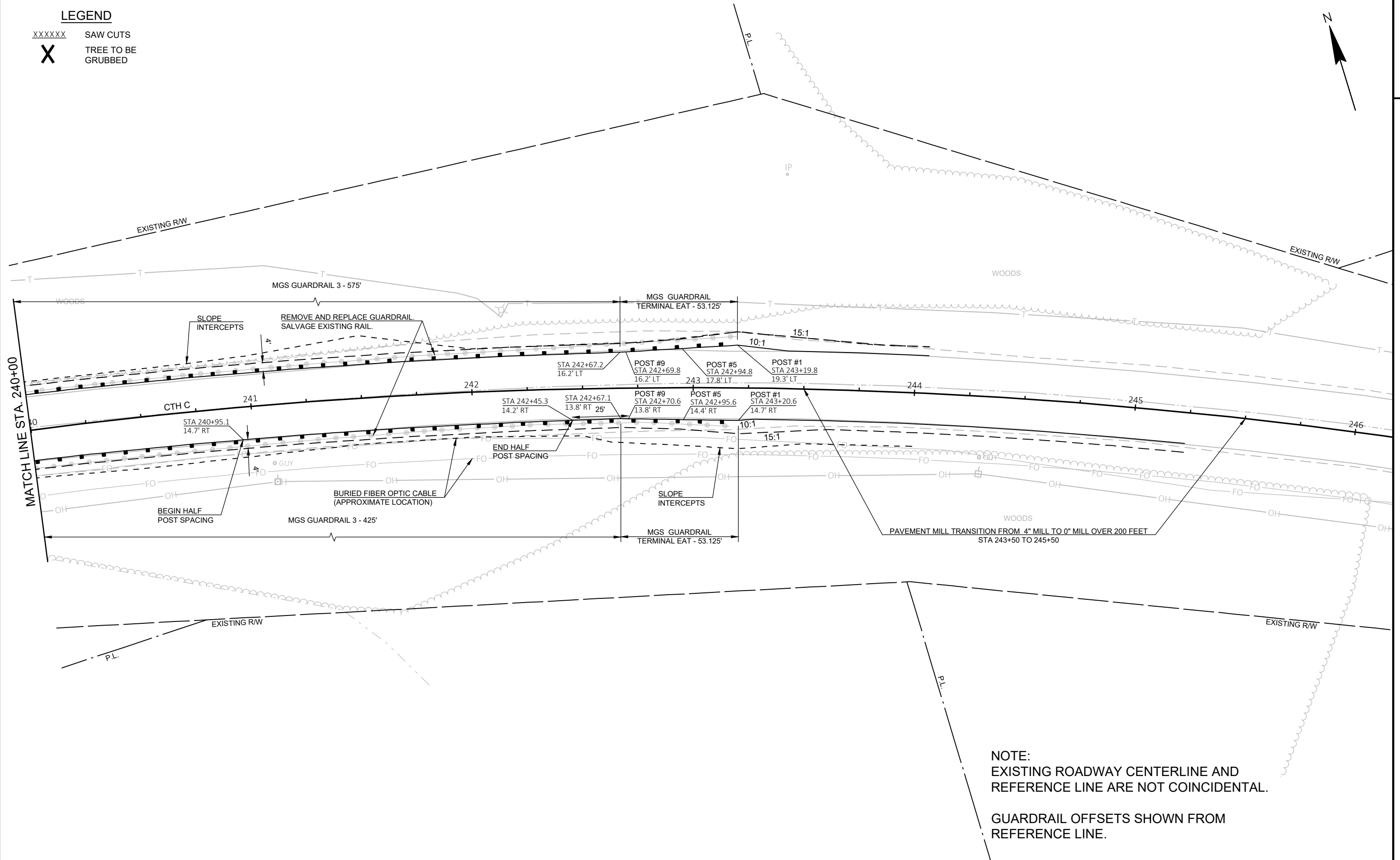

NOTE:  
 EXISTING ROADWAY CENTERLINE AND  
 REFERENCE LINE ARE NOT COINCIDENTAL.  
 GUARDRAIL OFFSETS SHOWN FROM  
 REFERENCE LINE.

**LEGEND**

- XXXXXX SAW CUTS
- X TREE TO BE GRUBBED

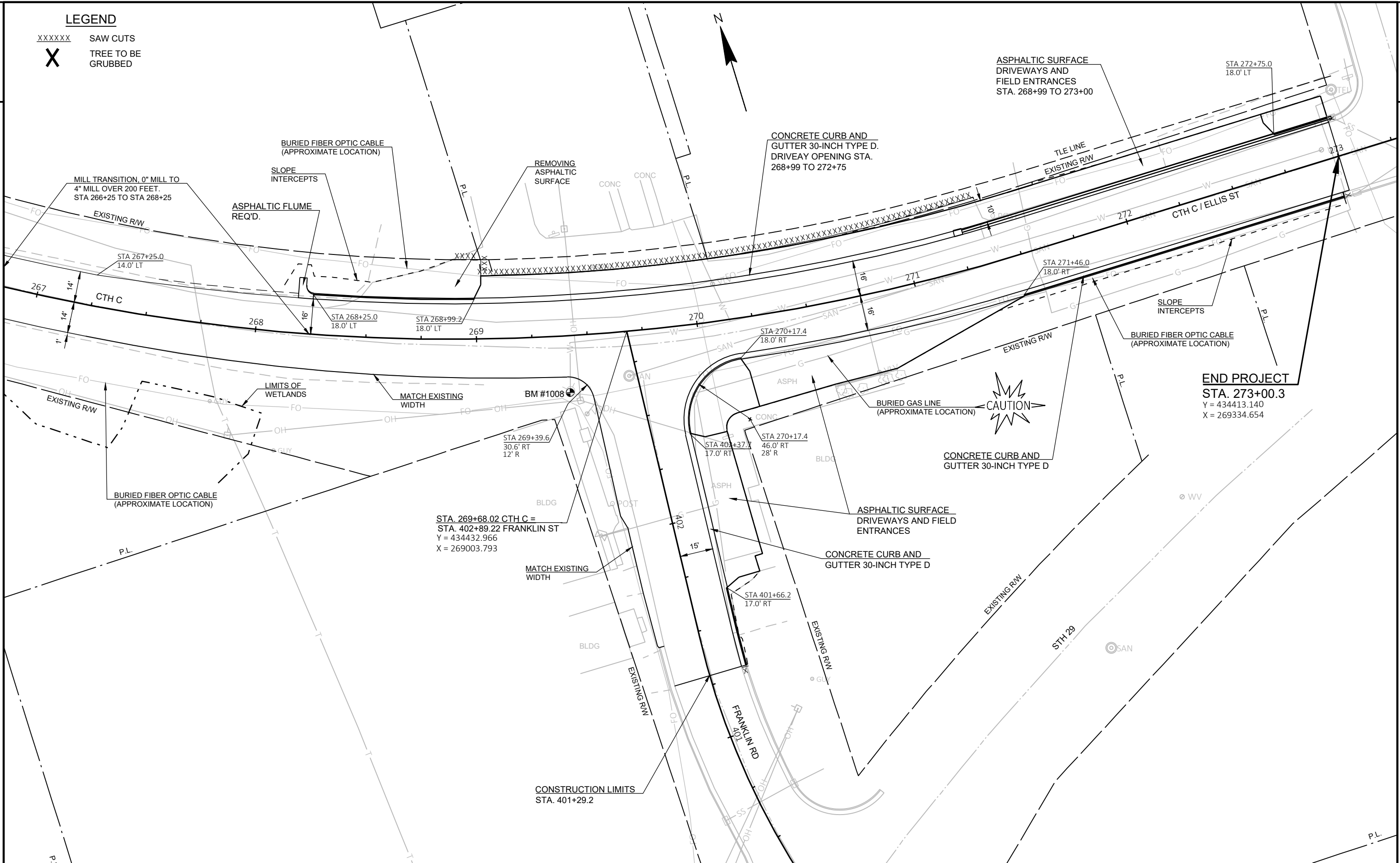

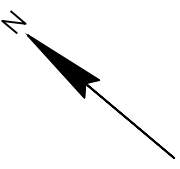

CULVERT PIPE NO. 100

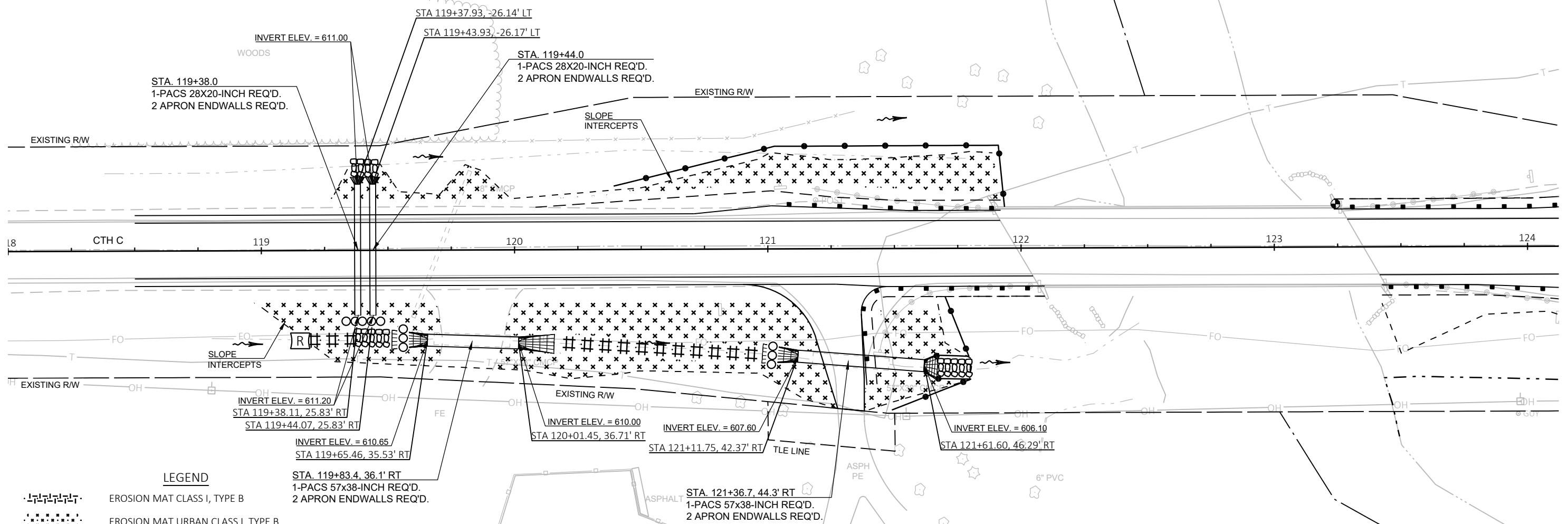

LEGEND

- EROSION MAT CLASS I, TYPE B
- EROSION MAT URBAN CLASS I, TYPE B
- EROSION MAT CLASS II, TYPE C
- SILT FENCE
- RIPRAP MEDIUM
- SLOPE INTERCEPT
- INLET PROTECTION
- ROCK BAGS
- CULVERT PIPE CHECK
- SURFACE WATER FLOW
- SAW CUTS
- TREE TO BE GRUBBED

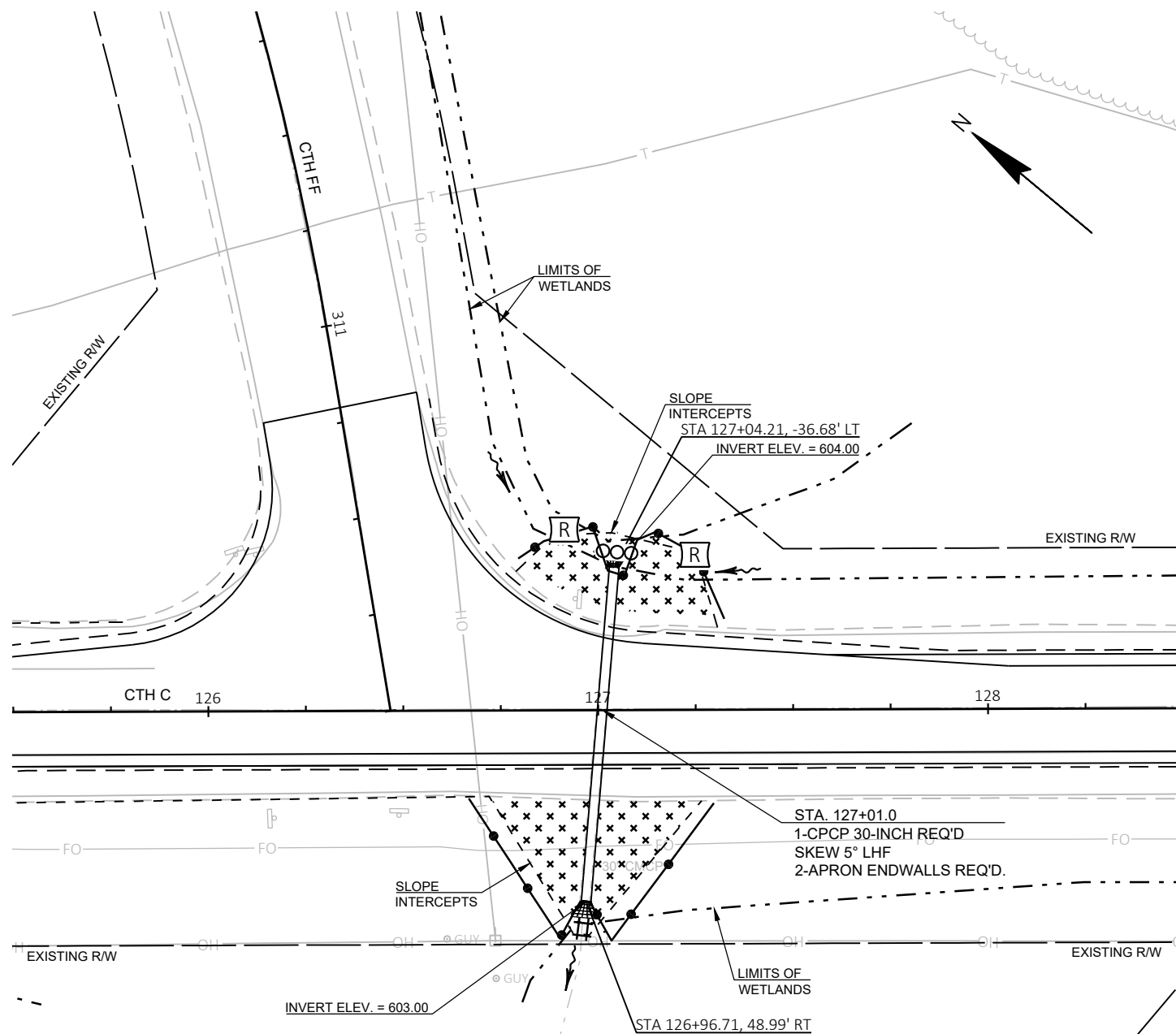

LEGEND

- EROSION MAT CLASS I, TYPE B
- EROSION MAT URBAN CLASS I, TYPE B
- EROSION MAT CLASS II, TYPE C
- SILT FENCE
- RIPRAP MEDIUM
- SLOPE INTERCEPT
- INLET PROTECTION
- ROCK BAGS
- CULVERT PIPE CHECK
- SURFACE WATER FLOW
- SAW CUTS
- TREE TO BE GRUBBED

CULVERT PIPE NO. 101

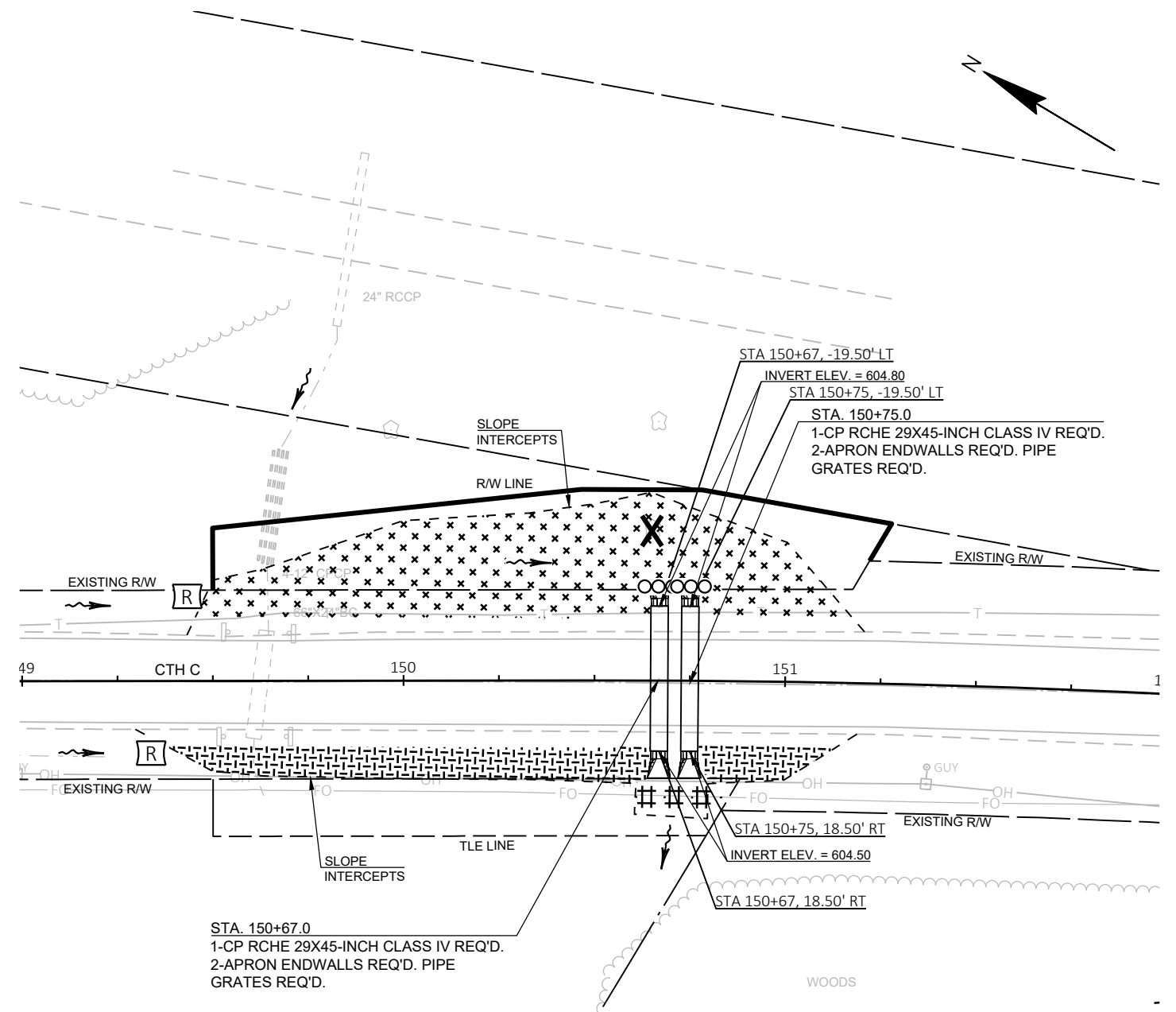

CULVERT PIPE NO. 102

BENCH MARKS

NO.	STATION	DESCRIPTION	ELEV.
1004	158+42	RR SPIKE ON PP 2324-14W09 - 17' RT	615.93

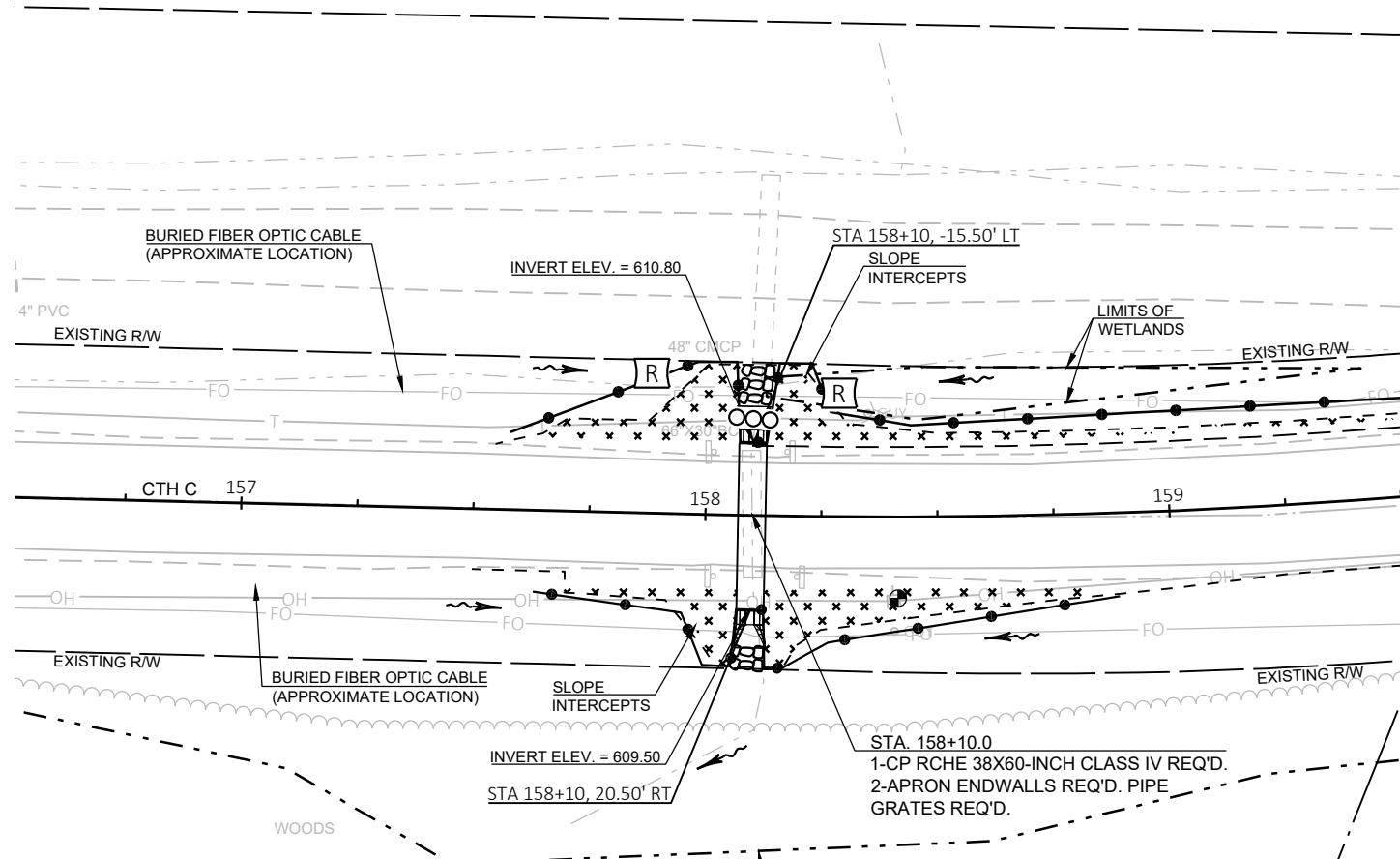

LEGEND

- EROSION MAT CLASS I, TYPE B
- EROSION MAT URBAN CLASS I, TYPE B
- EROSION MAT CLASS II, TYPE C
- SILT FENCE
- RIPRAP MEDIUM
- SLOPE INTERCEPT
- INLET PROTECTION
- ROCK BAGS
- CULVERT PIPE CHECK
- SURFACE WATER FLOW
- SAW CUTS
- TREE TO BE GRUBBED

CULVERT PIPE NO. 103

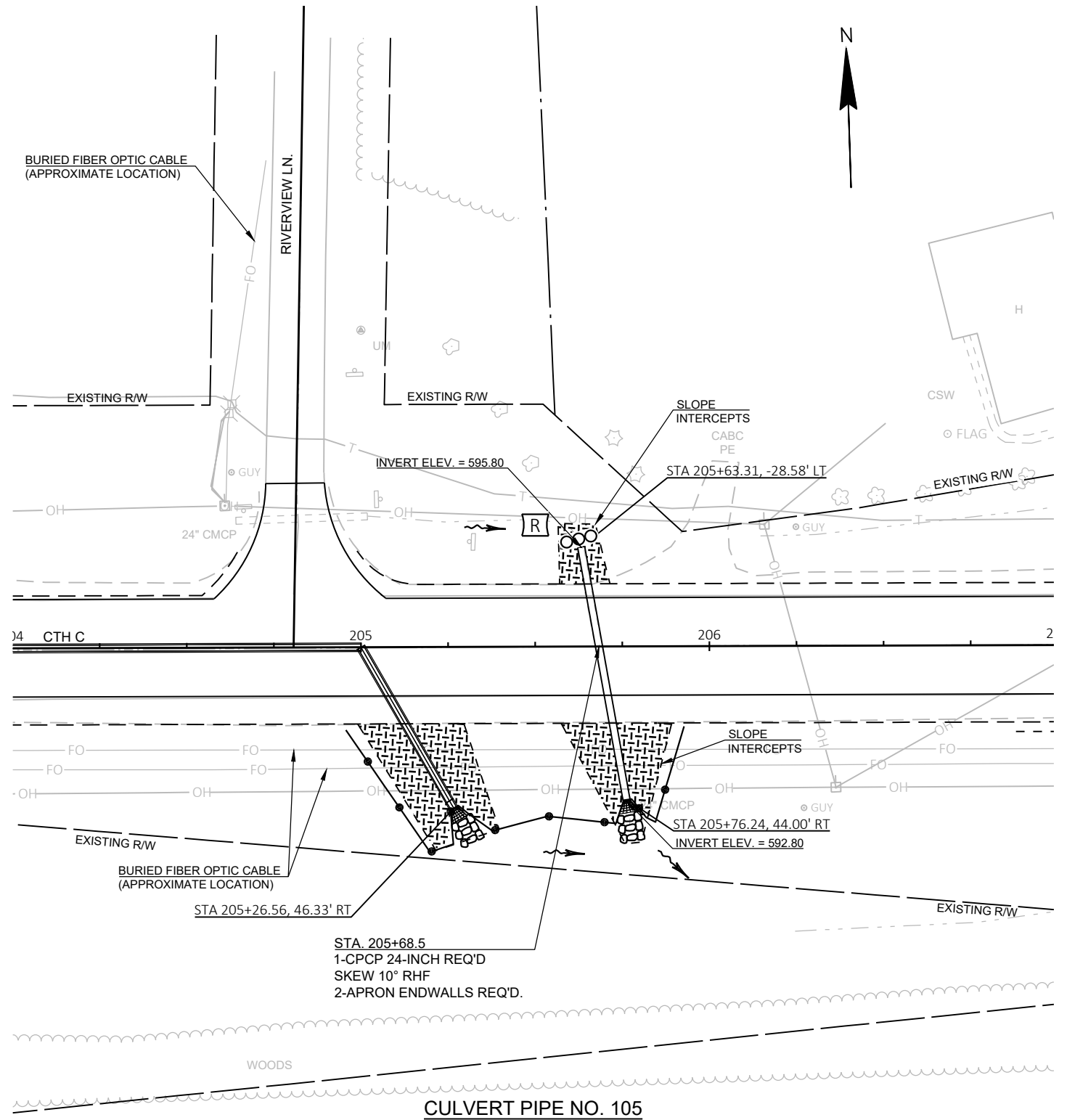

CULVERT PIPE NO. 105

LOCATION 1: CTH C 3550 FT SOUTH-SOUTH EAST OF CTH FF

**LEGEND**

- XX  
YYY.YY POINT NUMBER & ELEVATION
- SLOPE INTERCEPTS
- (SW6) CONCRETE SIDEWALK 6-INCH W/  
DETECTABLE WARNING FIELD
- 621.561 PROPOSED ROAD FINISHED  
SURFACE GRADE

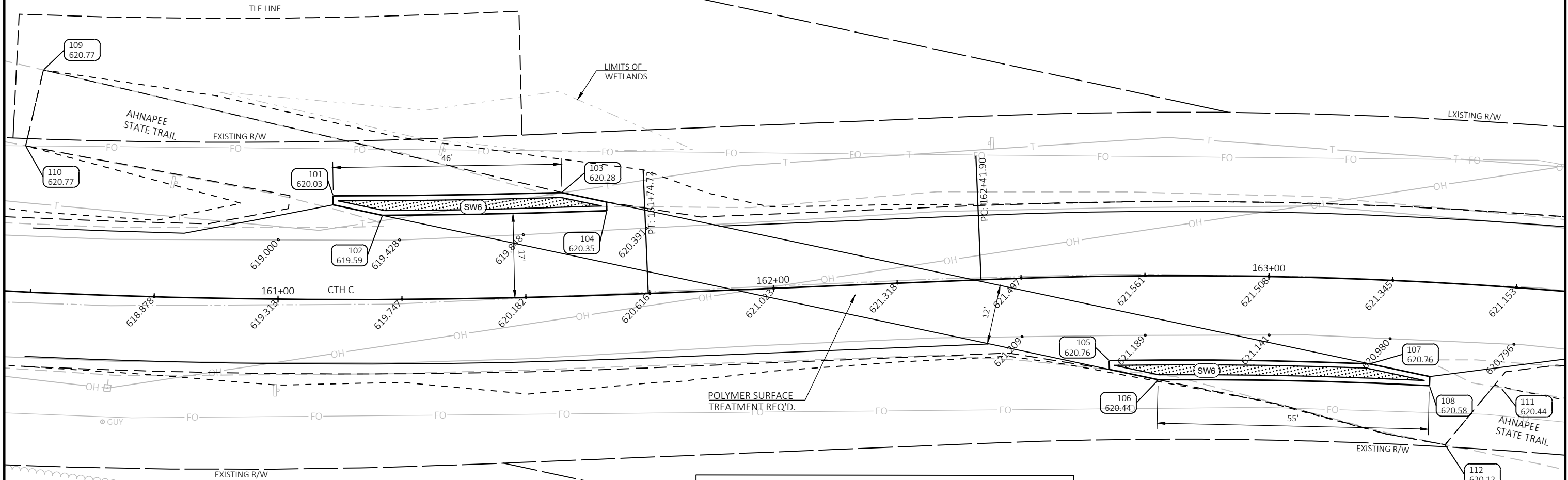
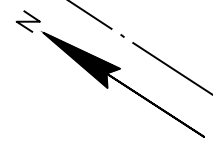

CR100					
POINT NUMBER	STATION	OFFSET	ELEVATION	NORTHING	EASTING
101	161+11.07	20.92' LT	620.03	438180.87	259932.00
102	161+21.13	16.99' LT	619.59	438170.40	259934.13
103	161+57.86	20.99' LT	620.28	438142.58	259957.68
104	161+66.94	17.00' LT	620.35	438132.95	259959.53
105	162+67.52	17.00' RT	620.76	438031.48	259989.42
106	162+77.64	20.97' RT	620.44	438021.02	259991.59
107	163+21.04	17.00' RT	620.76	437987.03	260017.49
108	163+33.50	20.85' RT	620.58	437974.54	260020.32
109	160+50.62	44.92' LT	620.77	438243.74	259921.47
110	160+47.67	29.47' LT	620.77	438238.42	259906.68
111	163+48.40	20.56' RT	620.44	437961.99	260027.76
112	163+37.44	32.57' RT	620.12	437965.39	260012.07

- NOTES:**
1. CONTRACTOR TO FIELD VERIFY ELEVATION, GRADES, SLOPES, LENGTHS AND MATCH POINTS PRIOR TO CONSTRUCTION
  2. THE ENGINEER MAY ADJUST ELEVATIONS TO FIT FIELD CONDITIONS
  3. ALL STATION AND OFFSET INFORMATION REFERENCE CTH C OR CTH F R/L

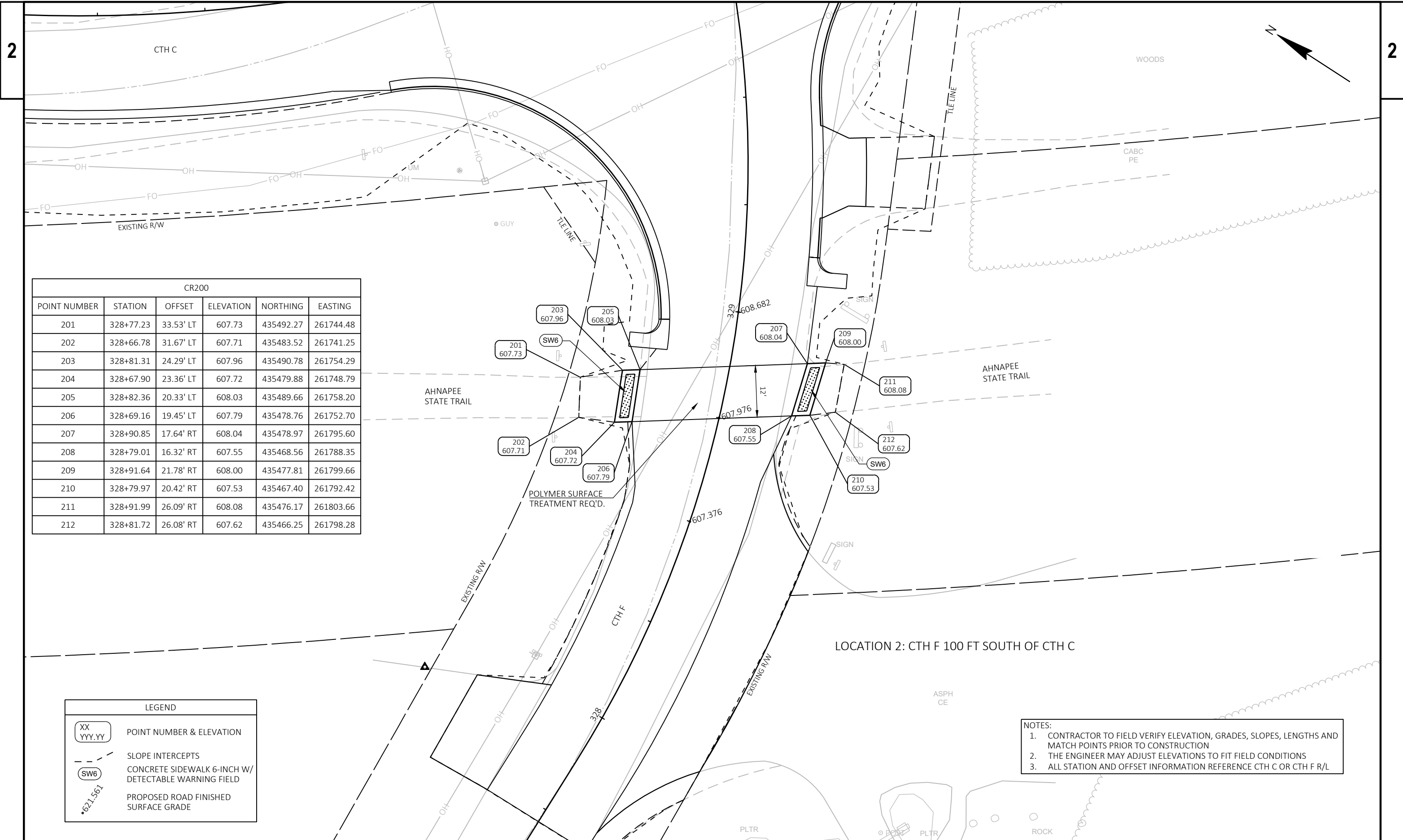

CR200					
POINT NUMBER	STATION	OFFSET	ELEVATION	NORTHING	EASTING
201	328+77.23	33.53' LT	607.73	435492.27	261744.48
202	328+66.78	31.67' LT	607.71	435483.52	261741.25
203	328+81.31	24.29' LT	607.96	435490.78	261754.29
204	328+67.90	23.36' LT	607.72	435479.88	261748.79
205	328+82.36	20.33' LT	608.03	435489.66	261758.20
206	328+69.16	19.45' LT	607.79	435478.76	261752.70
207	328+90.85	17.64' RT	608.04	435478.97	261795.60
208	328+79.01	16.32' RT	607.55	435468.56	261788.35
209	328+91.64	21.78' RT	608.00	435477.81	261799.66
210	328+79.97	20.42' RT	607.53	435467.40	261792.42
211	328+91.99	26.09' RT	608.08	435476.17	261803.66
212	328+81.72	26.08' RT	607.62	435466.25	261798.28

LEGEND	
XX YYY.YY	POINT NUMBER & ELEVATION
- - -	SLOPE INTERCEPTS
SW6	CONCRETE SIDEWALK 6-INCH W/ DETECTABLE WARNING FIELD
•621.561	PROPOSED ROAD FINISHED SURFACE GRADE

- NOTES:
1. CONTRACTOR TO FIELD VERIFY ELEVATION, GRADES, SLOPES, LENGTHS AND MATCH POINTS PRIOR TO CONSTRUCTION
  2. THE ENGINEER MAY ADJUST ELEVATIONS TO FIT FIELD CONDITIONS
  3. ALL STATION AND OFFSET INFORMATION REFERENCE CTH C OR CTH F R/L



LEGEND	
XX YYY.YY	POINT NUMBER & ELEVATION
- - -	SLOPE INTERCEPTS
(SW6)	CONCRETE SIDEWALK 6-INCH W/ DETECTABLE WARNING FIELD
• 621.561	PROPOSED ROAD FINISHED SURFACE GRADE

CTH C STATION & OFFSET TABLE					
POINT	STATION	OFFSET	Y COORDS	X COORDS	ELEVATION
301	226+90.4	21.0 LT	435765.762	265089.324	593.380
302	227+25.6	21.0 LT	435769.994	265124.290	593.420
303	226+82.8	17.0 LT	435760.887	265082.338	593.510
304	227+18.3	17.0 LT	435765.150	265117.557	593.550
305	225+53.0	17.0 RT	435711.535	264957.548	593.310
306	225+94.0	17.0 RT	435716.464	264998.270	593.370
307	225+44.2	21.0 RT	435706.501	264949.241	593.220
308	225+85.6	21.0 RT	435711.479	264990.374	593.280

CR300					
POINT NUMBER	STATION	OFFSET	ELEVATION	NORTHING	EASTING
309	227+37.79	35.67' LT	591.89	435786.03	265134.65
310	227+77.25	36.08' LT	591.41	435791.17	265173.77
311	225+08.75	29.24' RT	592.57	435694.06	264915.06
312	225+52.48	29.84' RT	592.75	435698.72	264958.55

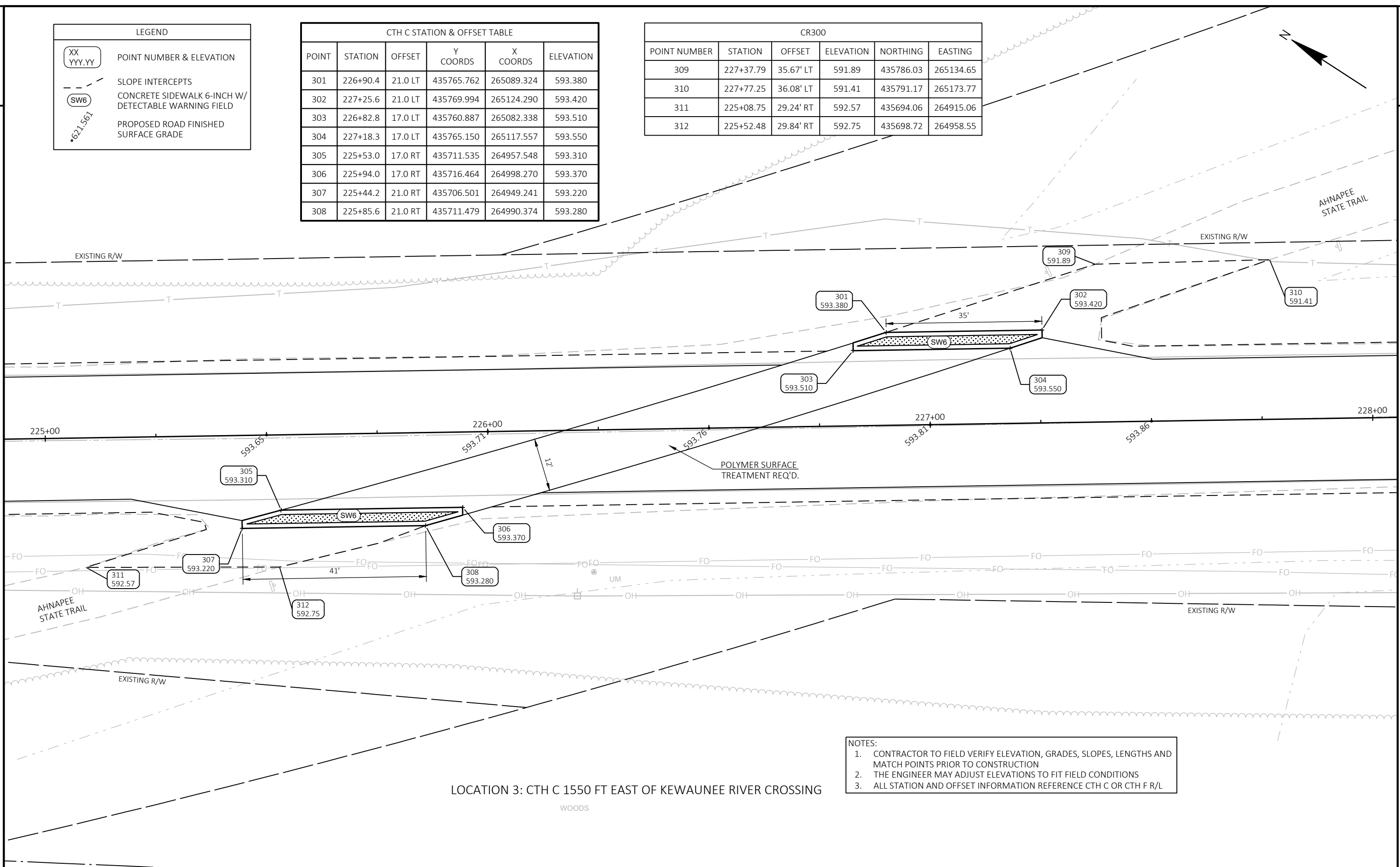
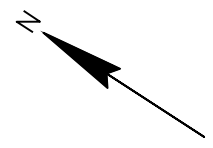

LOCATION 3: CTH C 1550 FT EAST OF KEWAUNEE RIVER CROSSING

- NOTES:
1. CONTRACTOR TO FIELD VERIFY ELEVATION, GRADES, SLOPES, LENGTHS AND MATCH POINTS PRIOR TO CONSTRUCTION
  2. THE ENGINEER MAY ADJUST ELEVATIONS TO FIT FIELD CONDITIONS
  3. ALL STATION AND OFFSET INFORMATION REFERENCE CTH C OR CTH F R/L

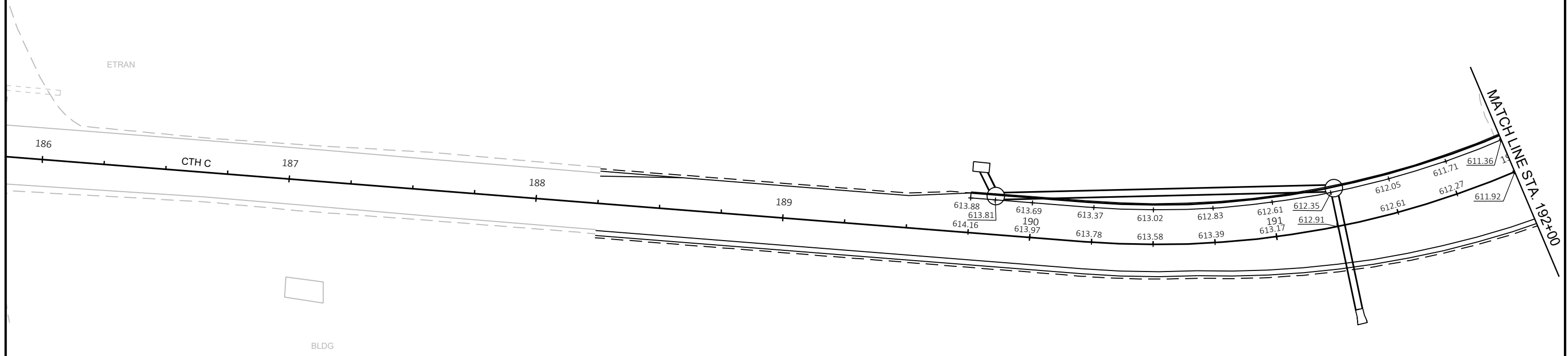
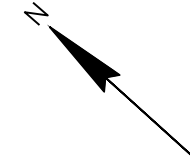

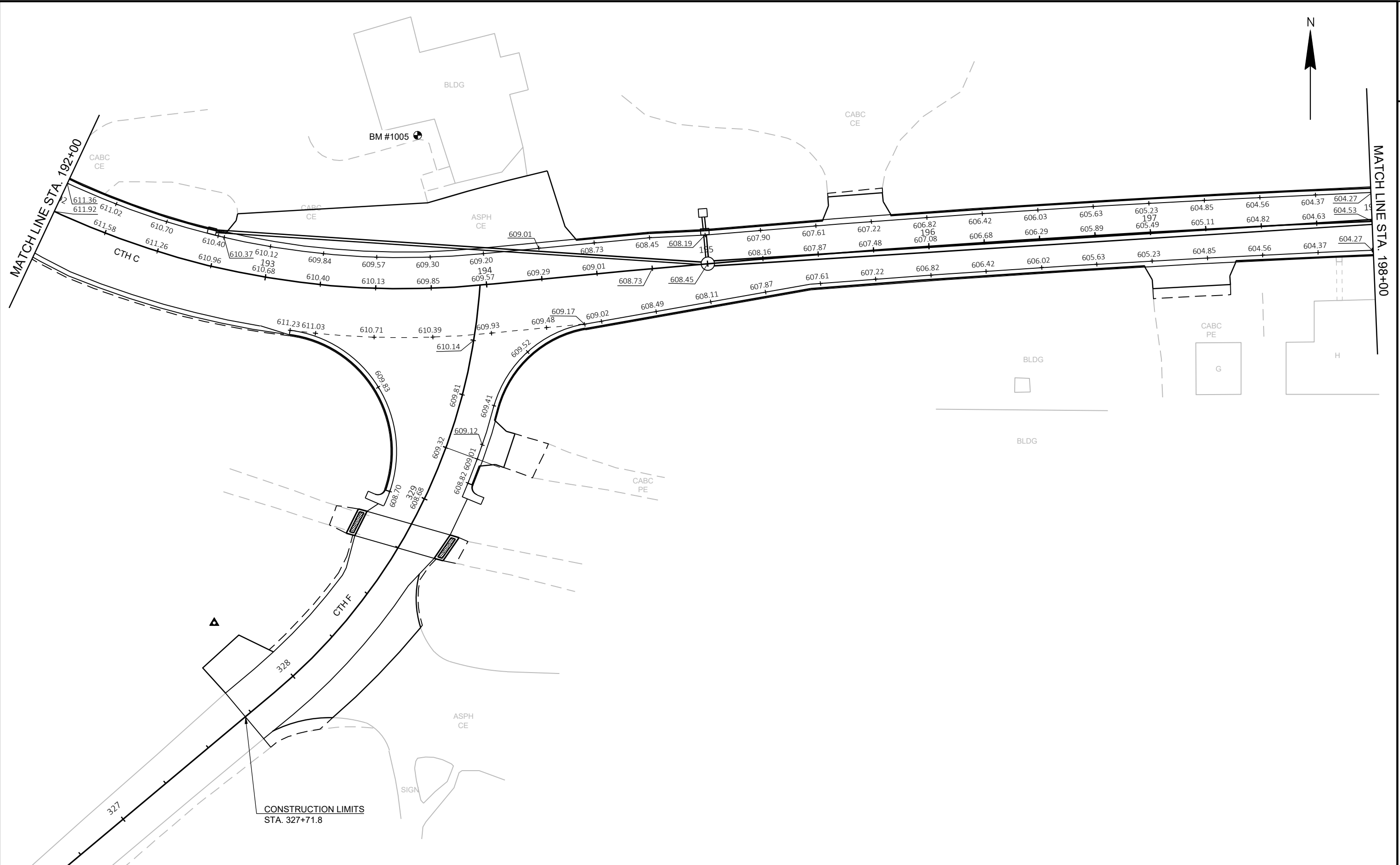

PROJECT NO: 4390-07-71	HWY: CTH C	COUNTY: KEWAUNEE	PLAN GRADES	SHEET	E
------------------------	------------	------------------	-------------	-------	---

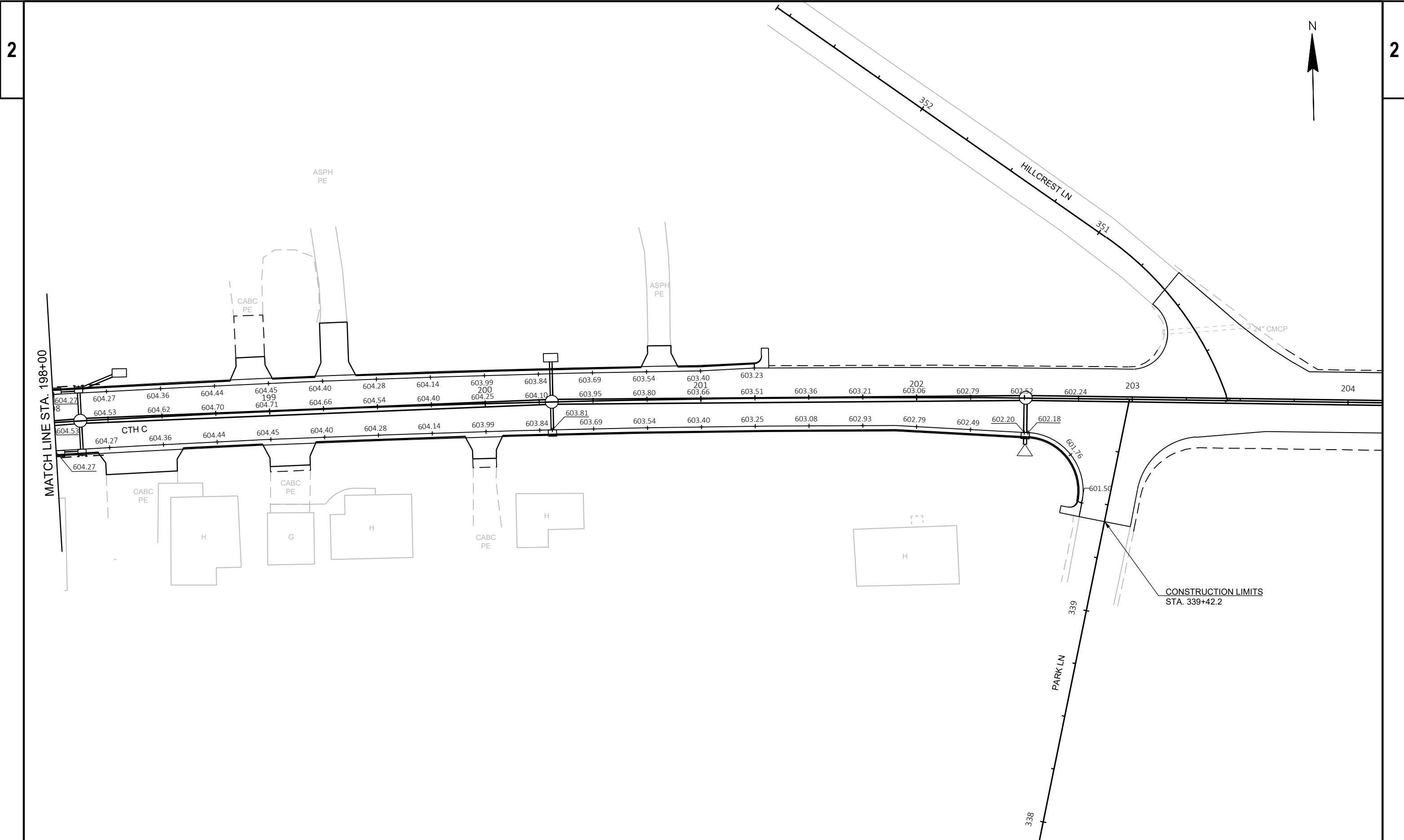



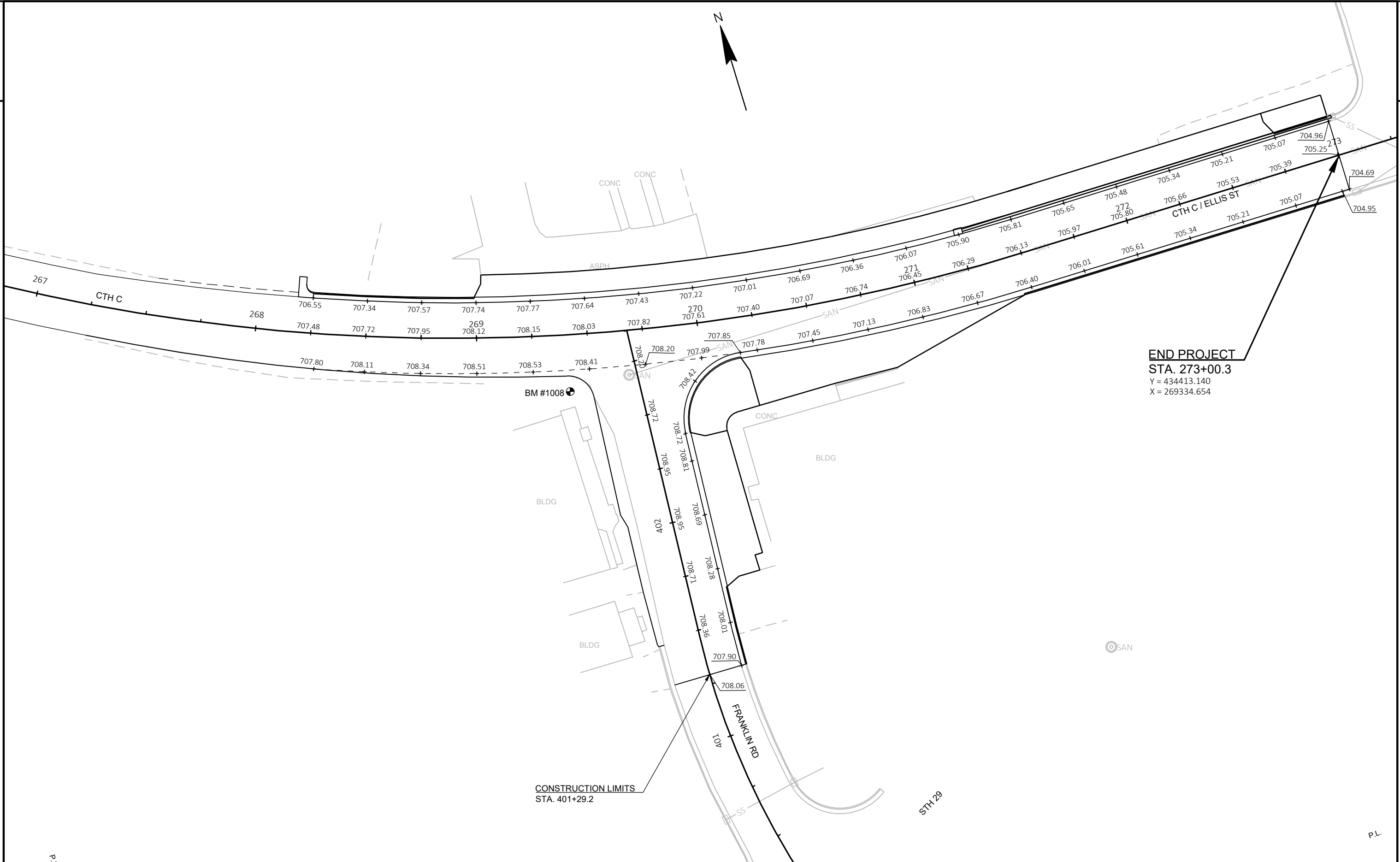





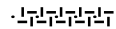

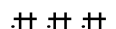
PROJECT NO: 4390-07-71	HWY: CTH C	COUNTY: KEWAUNEE	PLAN GRADES	SHEET	<b>E</b>
------------------------	------------	------------------	-------------	-------	----------

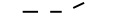

PROJECT NO: 4390-07-71	HWY: CTH C	COUNTY: KEWAUNEE	PLAN GRADES	SHEET	E
------------------------	------------	------------------	-------------	-------	---

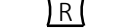
LEGEND

-  EROSION MAT CLASS I, TYPE B
-  EROSION MAT URBAN CLASS I, TYPE B
-  EROSION MAT CLASS II, TYPE C
-  SILT FENCE
-  RIPRAP MEDIUM
-  SLOPE INTERCEPT
-  INLET PROTECTION
-  ROCK BAGS
-  CULVERT PIPE CHECK
-  SURFACE WATER FLOW

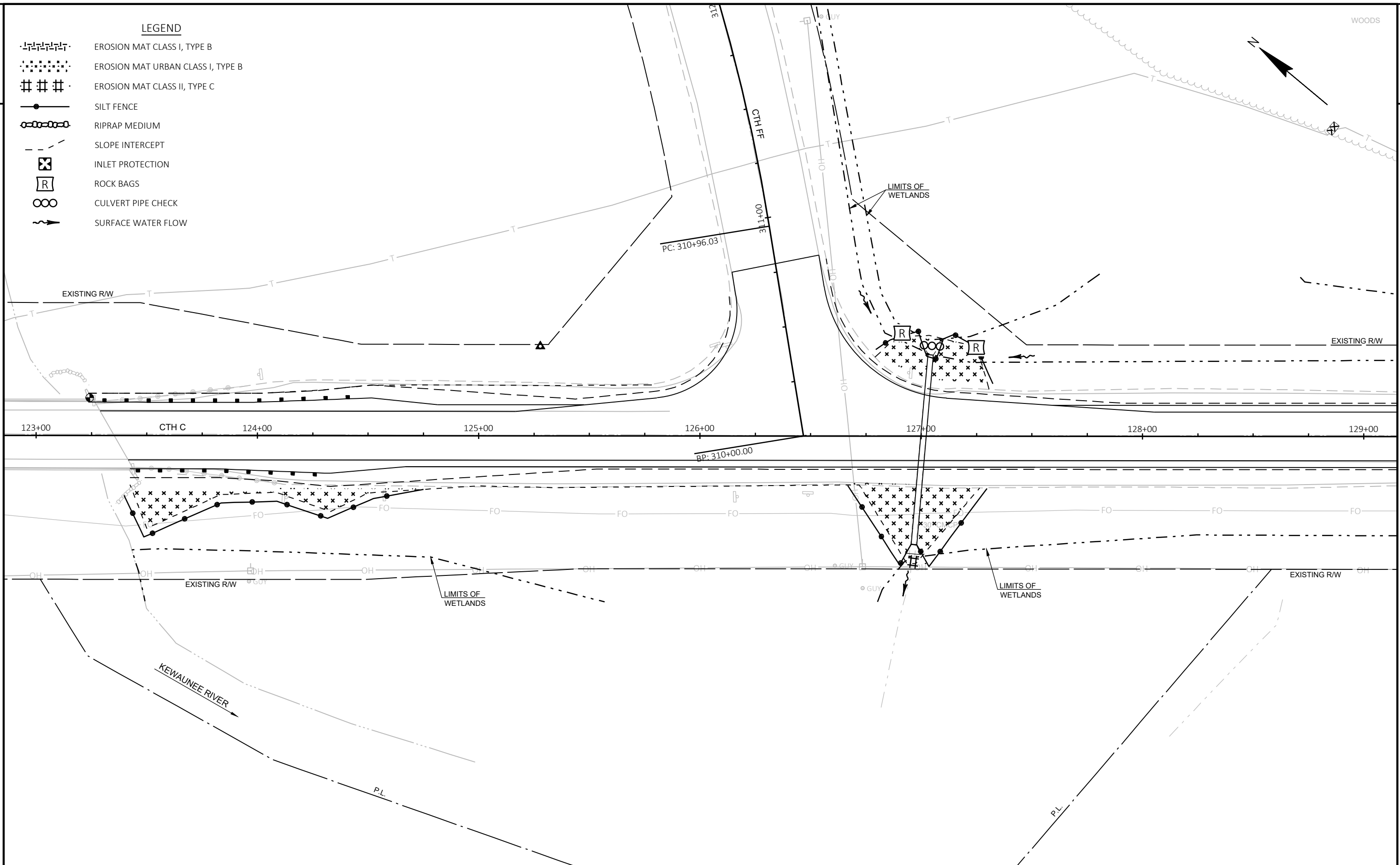

PROJECT NO: 4390-07-71

HWY: CTH C

COUNTY: KEWAUNEE

EROSION CONTROL

SHEET

E

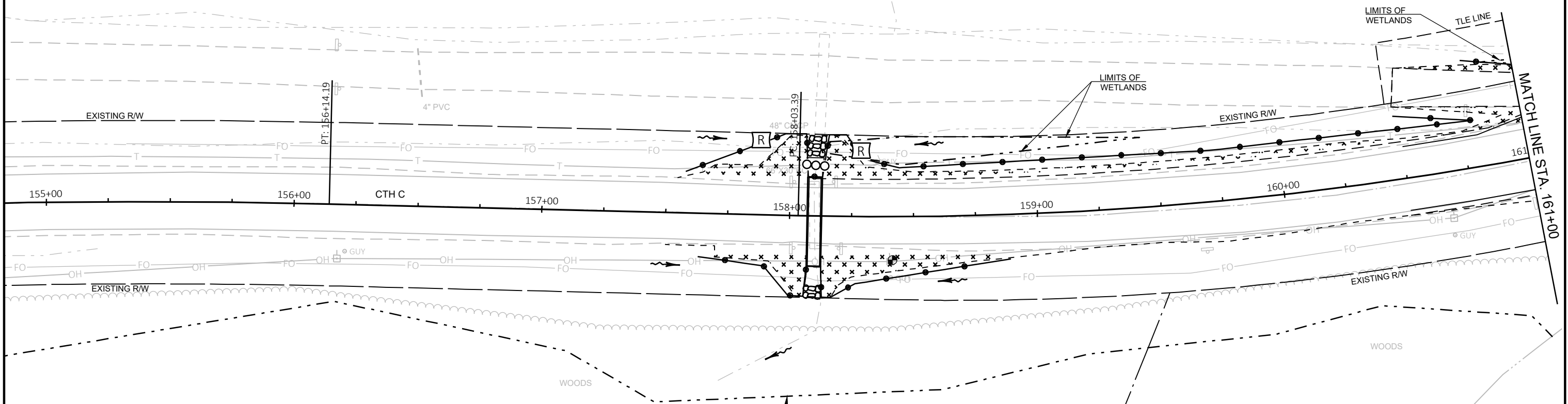
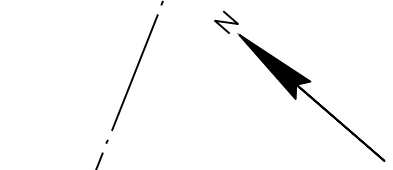





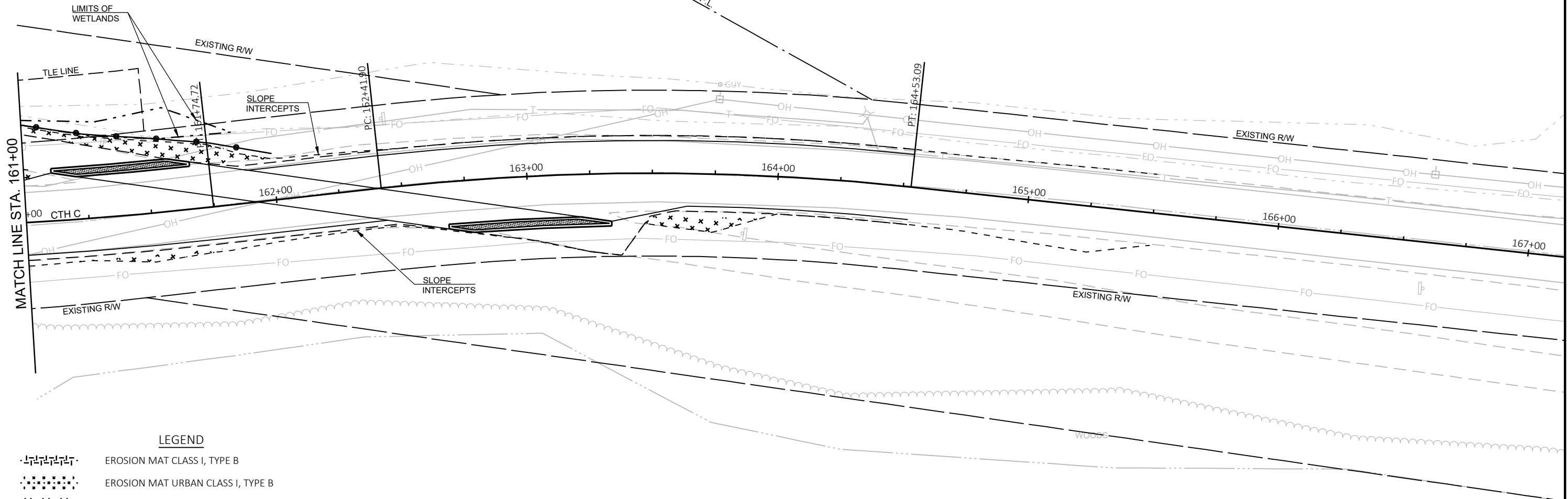
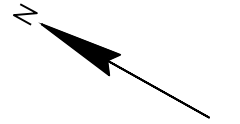

LEGEND

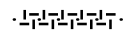
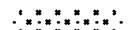
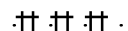
- EROSION MAT CLASS I, TYPE B
- EROSION MAT URBAN CLASS I, TYPE B
- EROSION MAT CLASS II, TYPE C
- SILT FENCE
- RIPRAP MEDIUM
- SLOPE INTERCEPT
- INLET PROTECTION
- ROCK BAGS
- CULVERT PIPE CHECK
- SURFACE WATER FLOW



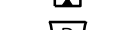
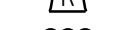







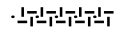

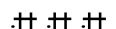
LEGEND

-  EROSION MAT CLASS I, TYPE B
-  EROSION MAT URBAN CLASS I, TYPE B
-  EROSION MAT CLASS II, TYPE C
-  SILT FENCE
-  RIPRAP MEDIUM
-  SLOPE INTERCEPT
-  INLET PROTECTION
-  ROCK BAGS
-  CULVERT PIPE CHECK
-  SURFACE WATER FLOW

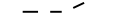

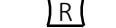
LEGEND



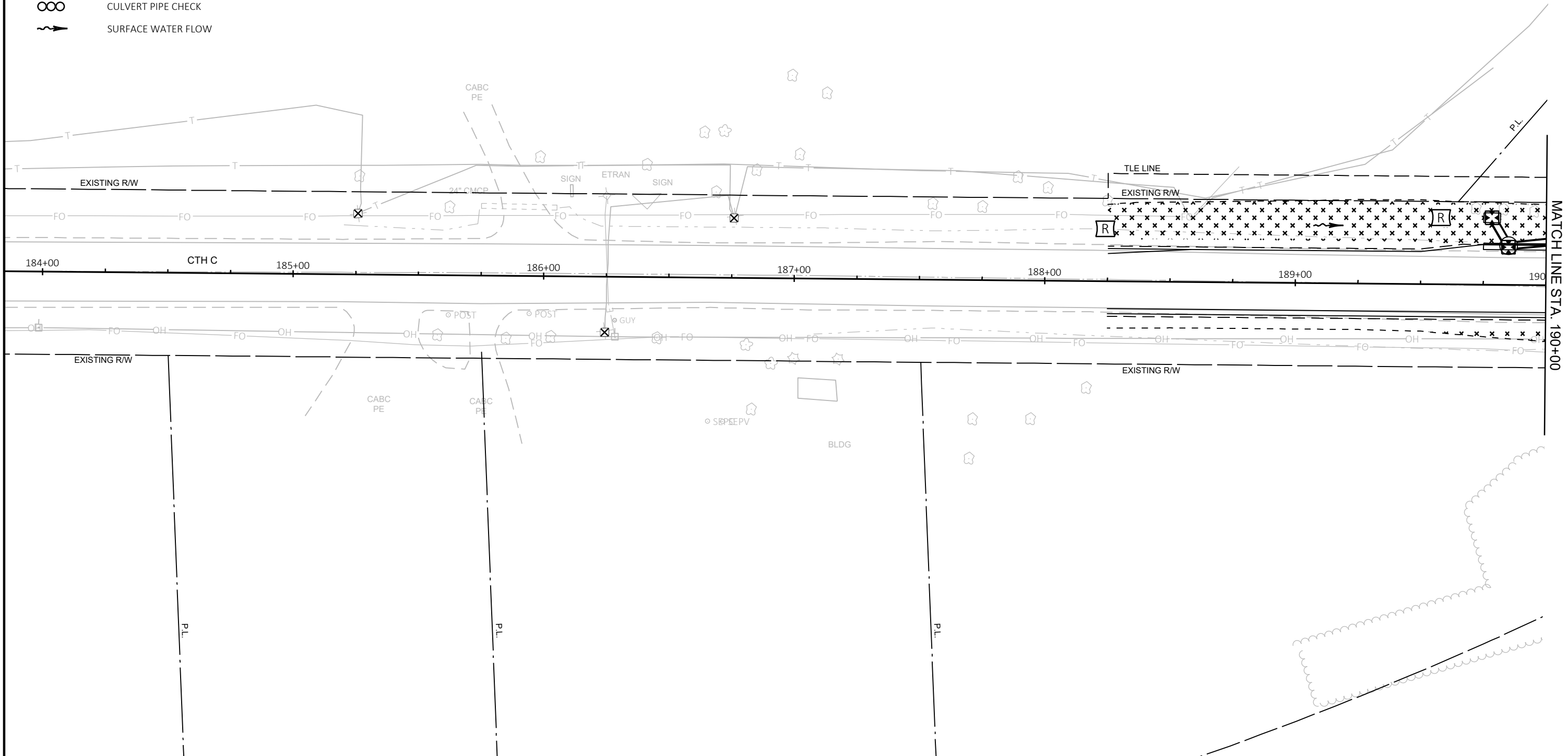
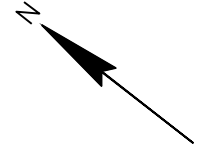





-  EROSION MAT CLASS I, TYPE B
-  EROSION MAT URBAN CLASS I, TYPE B
-  EROSION MAT CLASS II, TYPE C
-  SILT FENCE
-  RIPRAP MEDIUM
-  SLOPE INTERCEPT
-  INLET PROTECTION
-  ROCK BAGS
-  CULVERT PIPE CHECK
-  SURFACE WATER FLOW

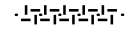

MATCH LINE STA. 190+00

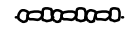
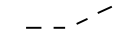
PROJECT NO: 4390-07-71	HWY: CTH C	COUNTY: KEWAUNEE	EROSION CONTROL	SHEET	<b>E</b>
------------------------	------------	------------------	-----------------	-------	----------

LEGEND

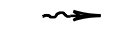
-  EROSION MAT CLASS I, TYPE B
-  EROSION MAT URBAN CLASS I, TYPE B
-  EROSION MAT CLASS II, TYPE C
-  SILT FENCE
-  RIPRAP MEDIUM
-  SLOPE INTERCEPT
-  INLET PROTECTION
-  ROCK BAGS
-  CULVERT PIPE CHECK
-  SURFACE WATER FLOW

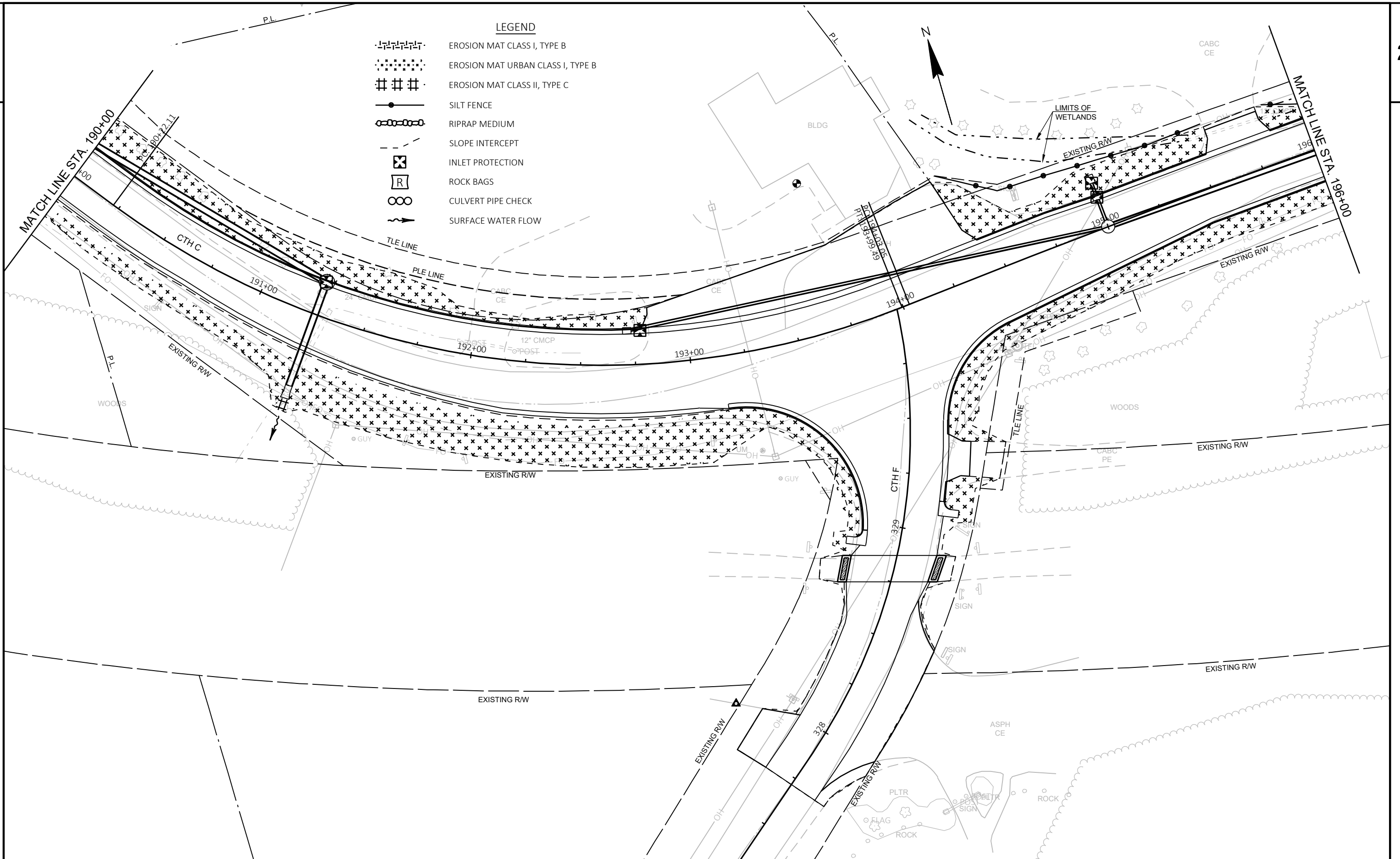

PROJECT NO: 4390-07-71

HWY: CTH C







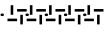

COUNTY: KEWAUNEE

EROSION CONTROL

SHEET

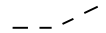



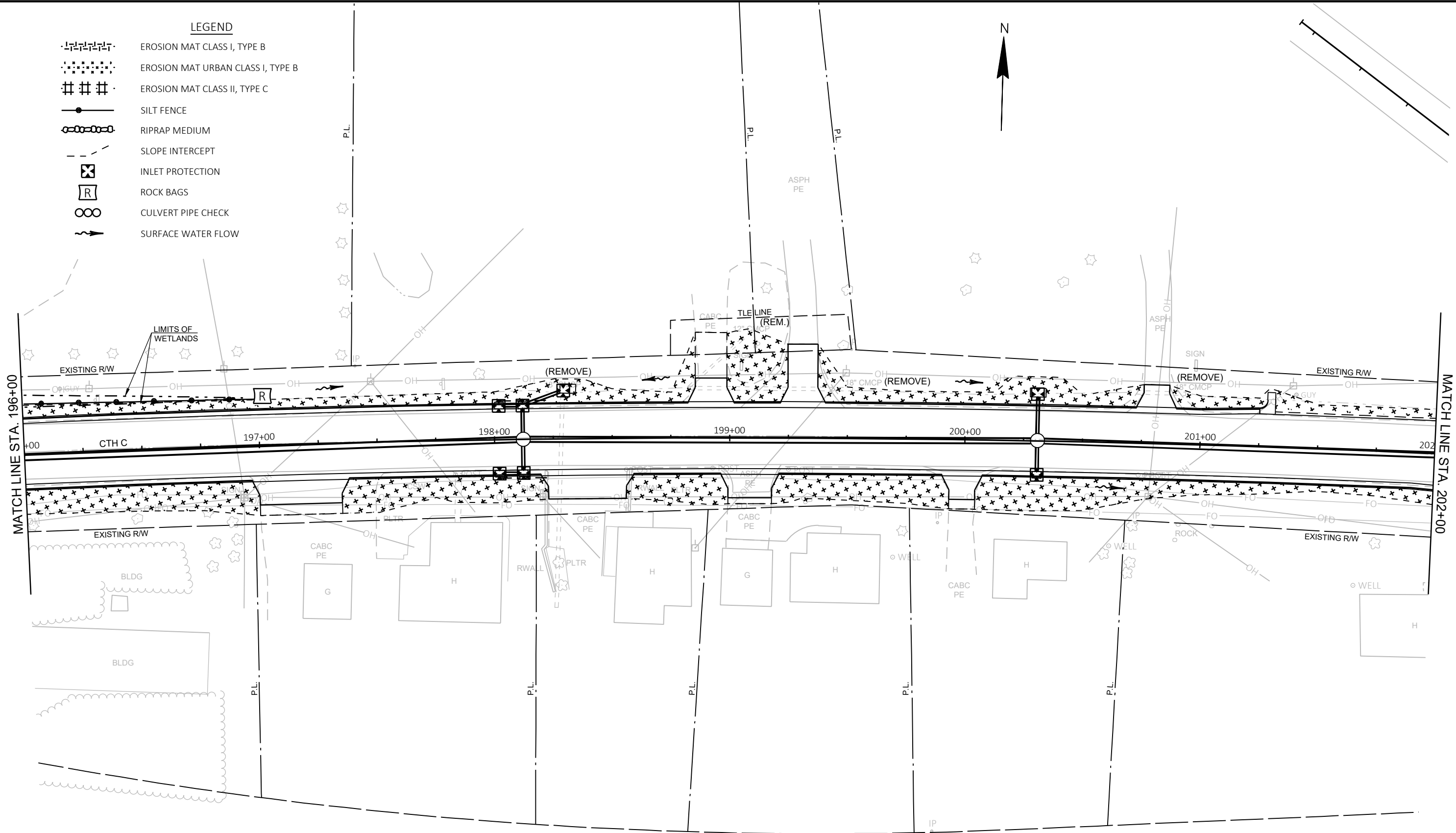

E

LEGEND

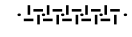
-  EROSION MAT CLASS I, TYPE B
-  EROSION MAT URBAN CLASS I, TYPE B
-  EROSION MAT CLASS II, TYPE C
-  SILT FENCE
-  RIPRAP MEDIUM
-  SLOPE INTERCEPT
-  INLET PROTECTION
-  ROCK BAGS
-  CULVERT PIPE CHECK
-  SURFACE WATER FLOW

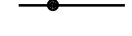
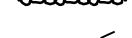

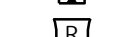
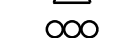
LEGEND



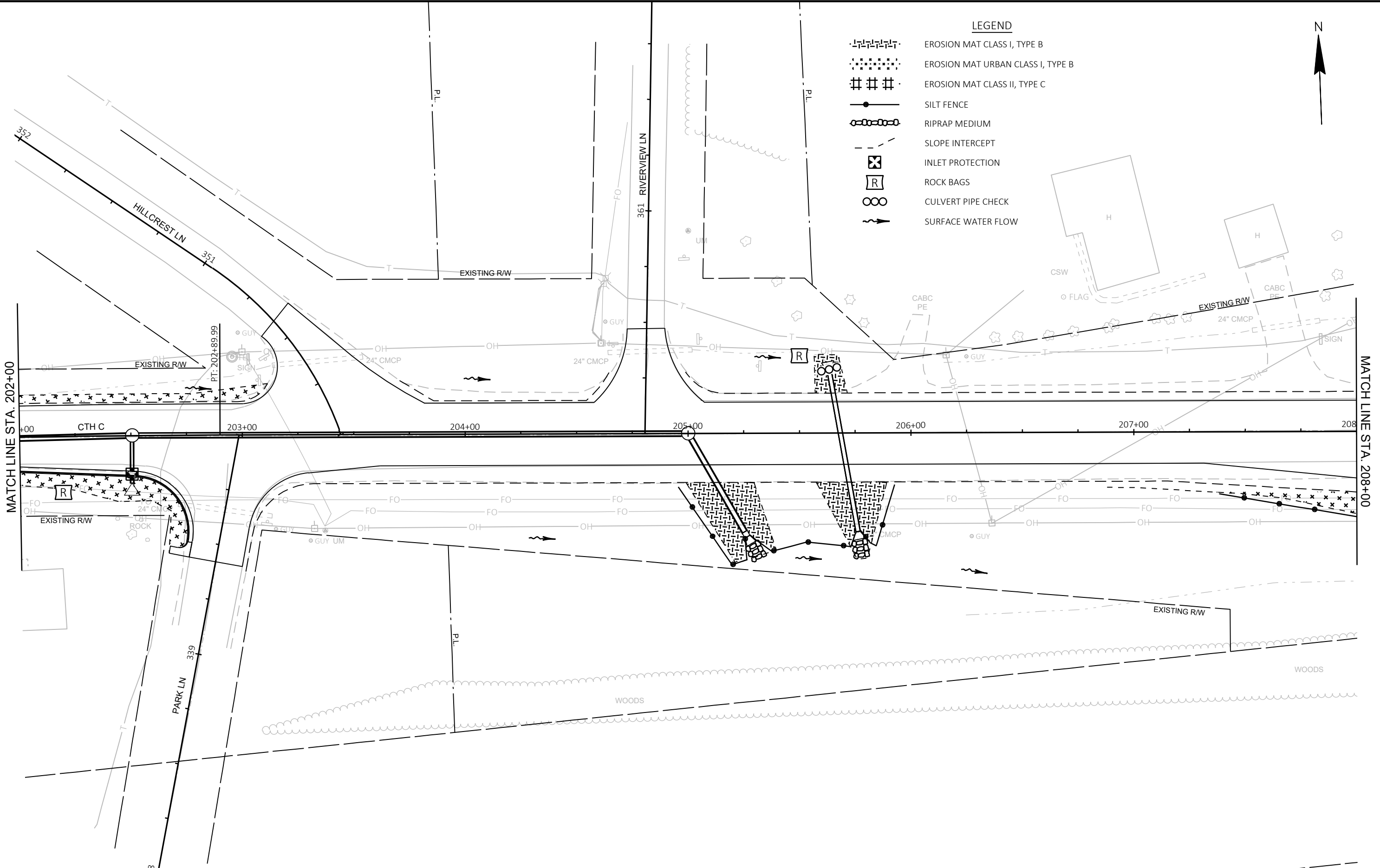



-  EROSION MAT CLASS I, TYPE B
-  EROSION MAT URBAN CLASS I, TYPE B
-  EROSION MAT CLASS II, TYPE C
-  SILT FENCE
-  RIPRAP MEDIUM
-  SLOPE INTERCEPT
-  INLET PROTECTION
-  ROCK BAGS
-  CULVERT PIPE CHECK
-  SURFACE WATER FLOW



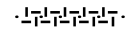

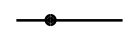
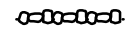
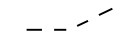



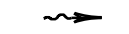

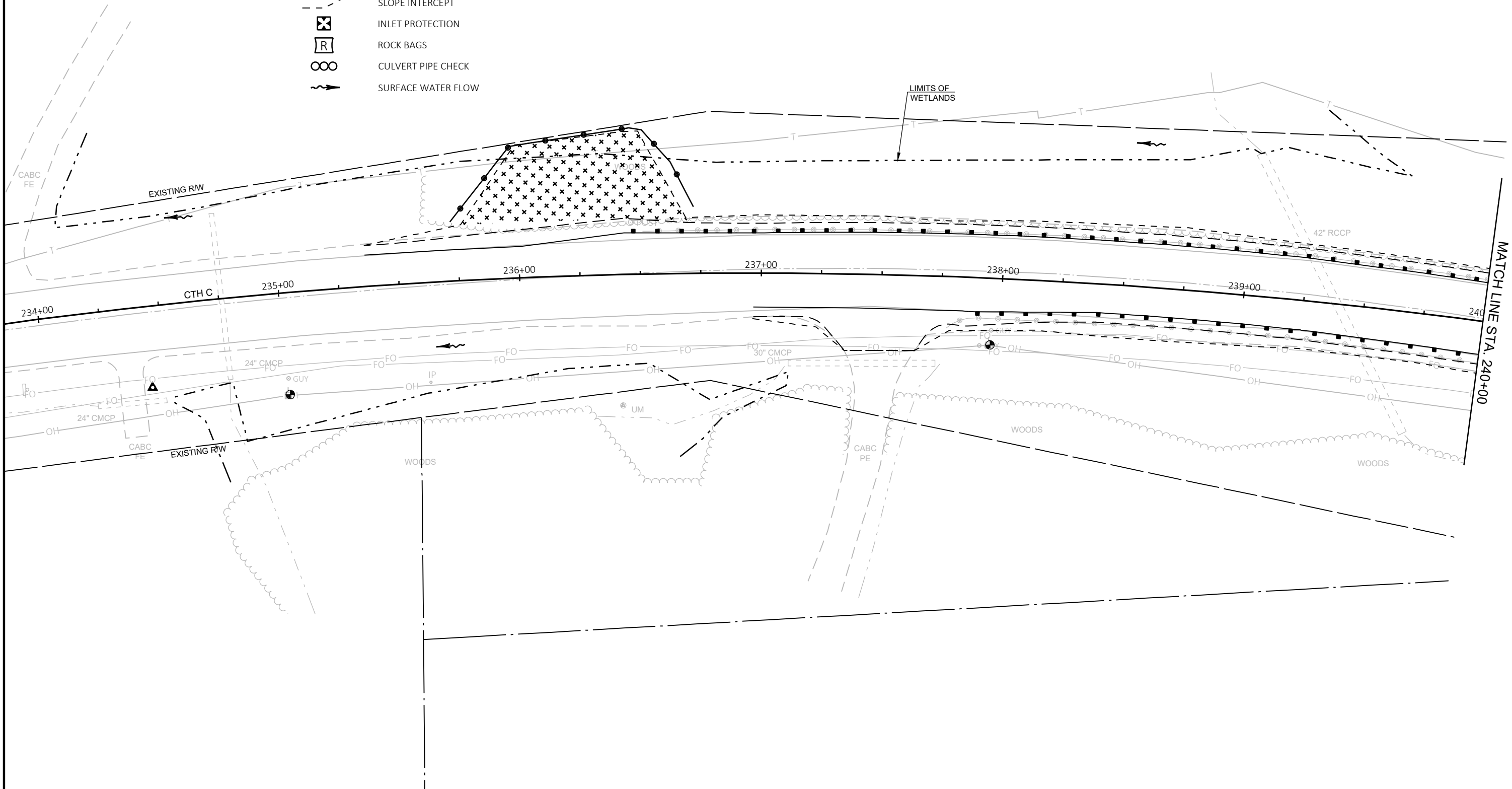
LEGEND

-  EROSION MAT CLASS I, TYPE B
-  EROSION MAT URBAN CLASS I, TYPE B
-  EROSION MAT CLASS II, TYPE C
-  SILT FENCE
-  RIPRAP MEDIUM
-  SLOPE INTERCEPT
-  INLET PROTECTION
-  ROCK BAGS
-  CULVERT PIPE CHECK
-  SURFACE WATER FLOW

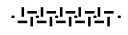
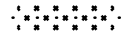
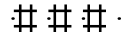
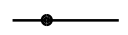
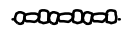
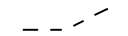

PROJECT NO: 4390-07-71	HWY: CTH C	COUNTY: KEWAUNEE	EROSION CONTROL	SHEET	<b>E</b>
------------------------	------------	------------------	-----------------	-------	----------

LEGEND

-  EROSION MAT CLASS I, TYPE B
-  EROSION MAT URBAN CLASS I, TYPE B
-  EROSION MAT CLASS II, TYPE C
-  SILT FENCE
-  RIPRAP MEDIUM
-  SLOPE INTERCEPT
-  INLET PROTECTION
-  ROCK BAGS
-  CULVERT PIPE CHECK
-  SURFACE WATER FLOW EXISTING RW

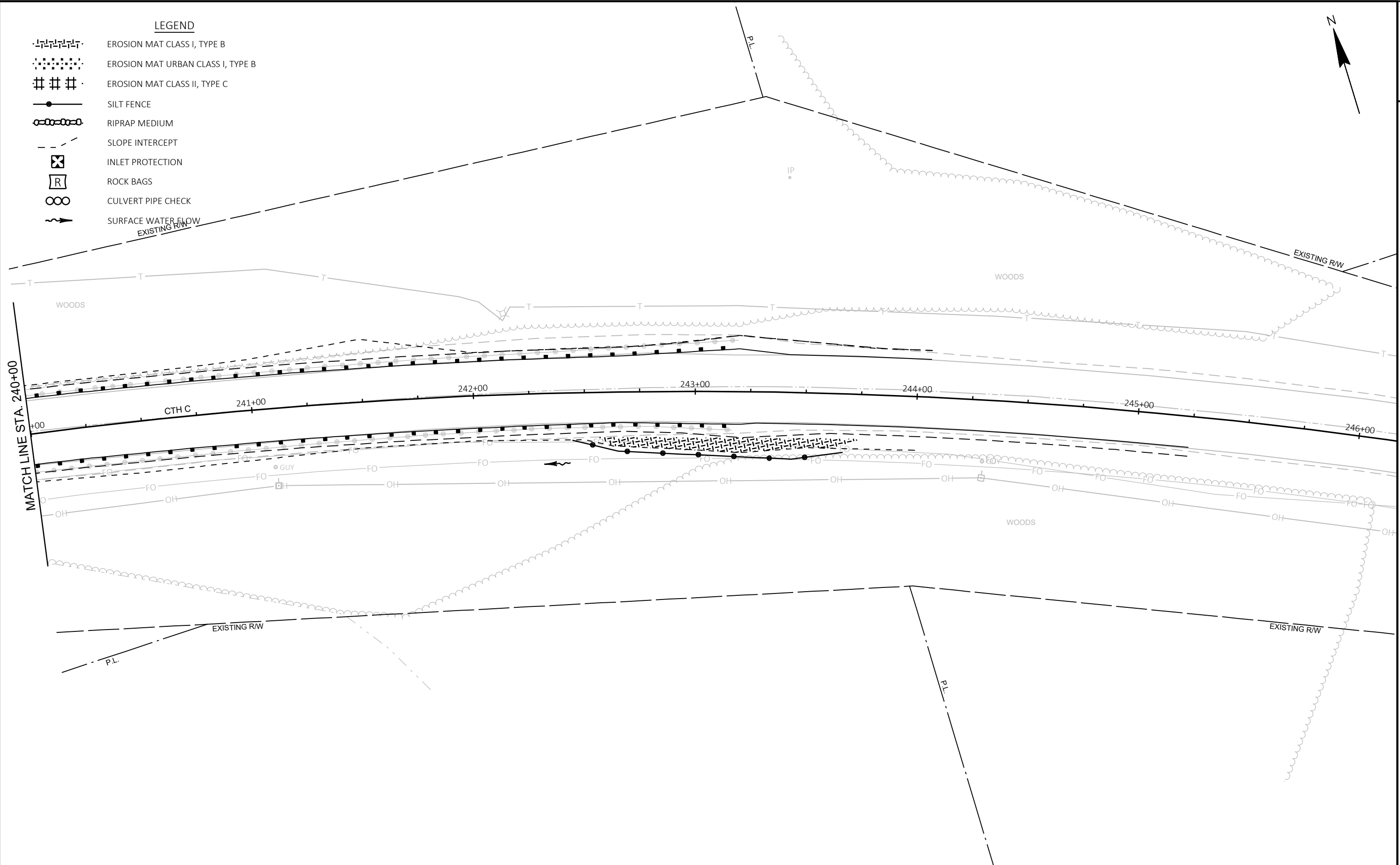

PROJECT NO: 4390-07-71	HWY: CTH C	COUNTY: KEWAUNEE	EROSION CONTROL	SHEET	<b>E</b>
------------------------	------------	------------------	-----------------	-------	----------

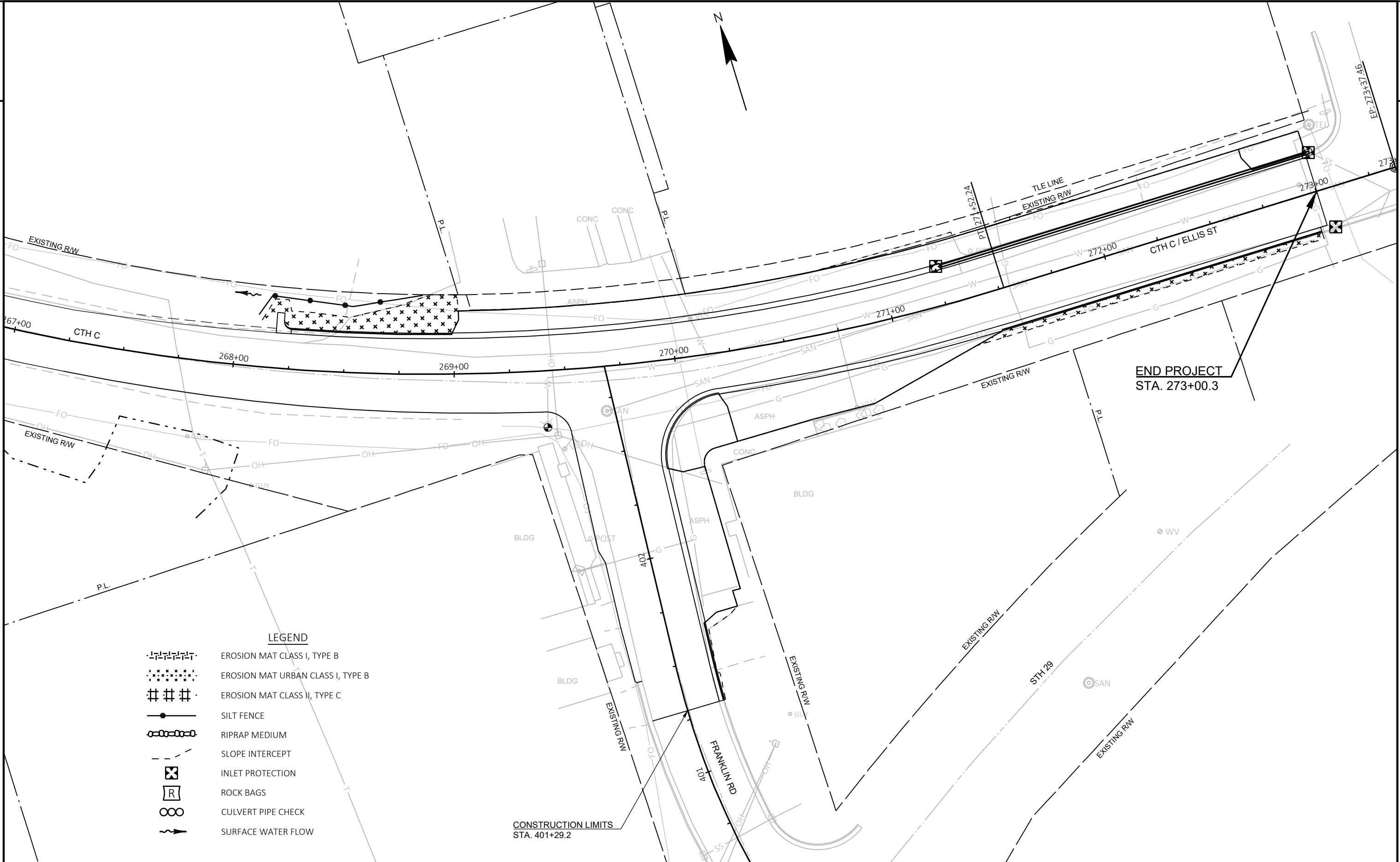

LEGEND

- EROSION MAT CLASS I, TYPE B
- EROSION MAT URBAN CLASS I, TYPE B
- EROSION MAT CLASS II, TYPE C
- SILT FENCE
- RIPRAP MEDIUM
- SLOPE INTERCEPT
- INLET PROTECTION
- ROCK BAGS
- CULVERT PIPE CHECK
- SURFACE WATER FLOW

CONSTRUCTION LIMITS  
STA. 401+29.2

END PROJECT  
STA. 273+00.3



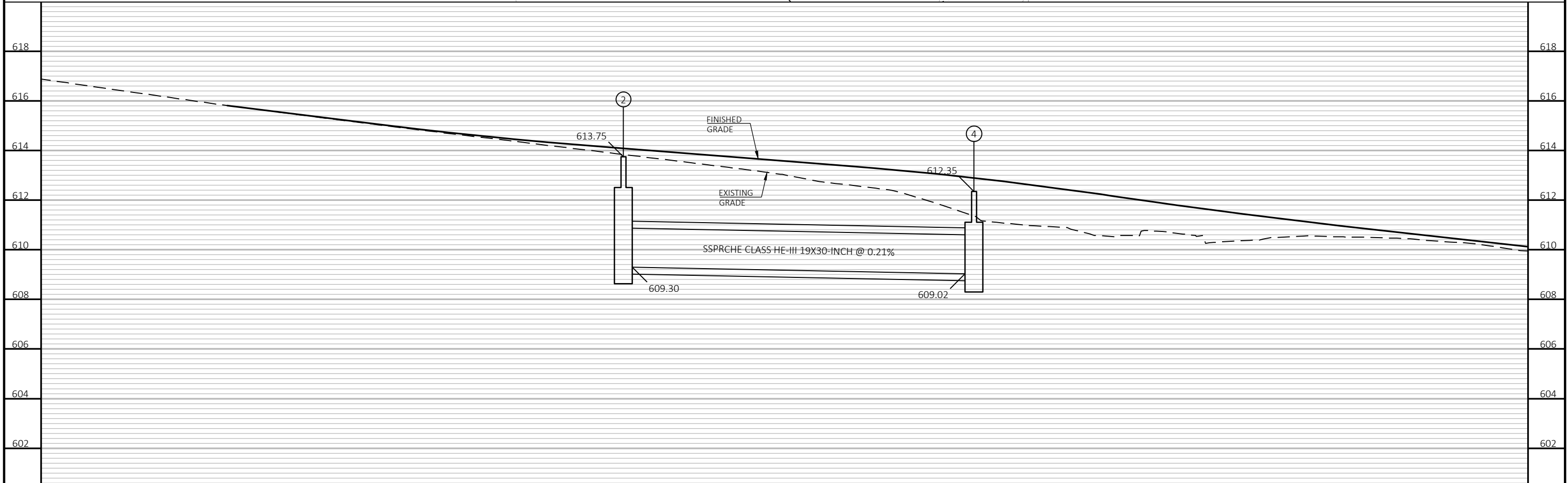
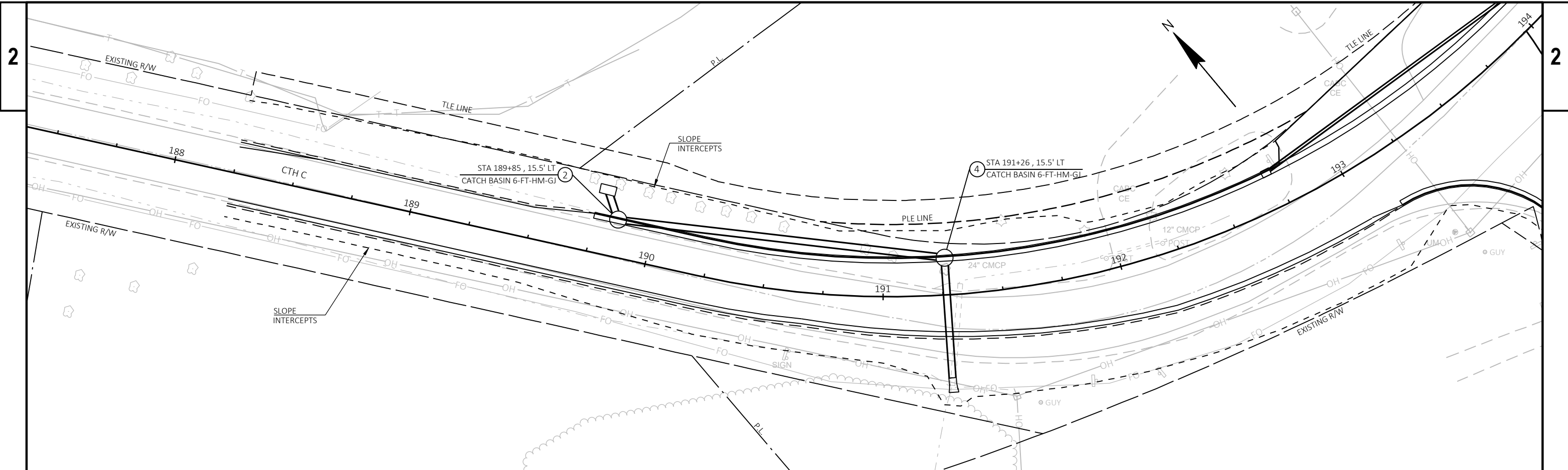

PROJECT NO: 4390-07-71	HWY: CTH C	COUNTY: KEWAUNEE	STORM SEWER PLAN	SHEET	<b>E</b>
------------------------	------------	------------------	------------------	-------	----------

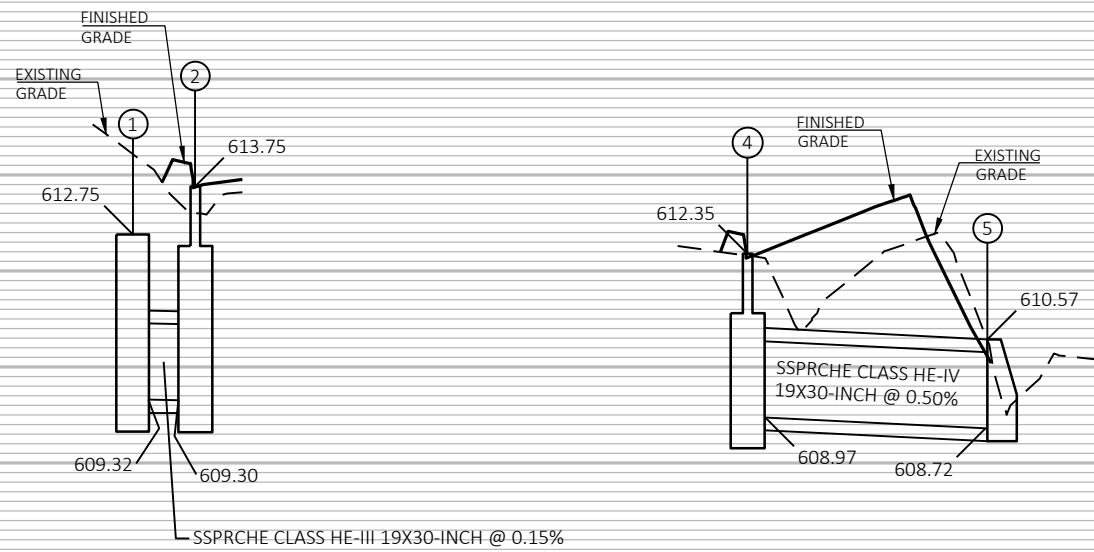
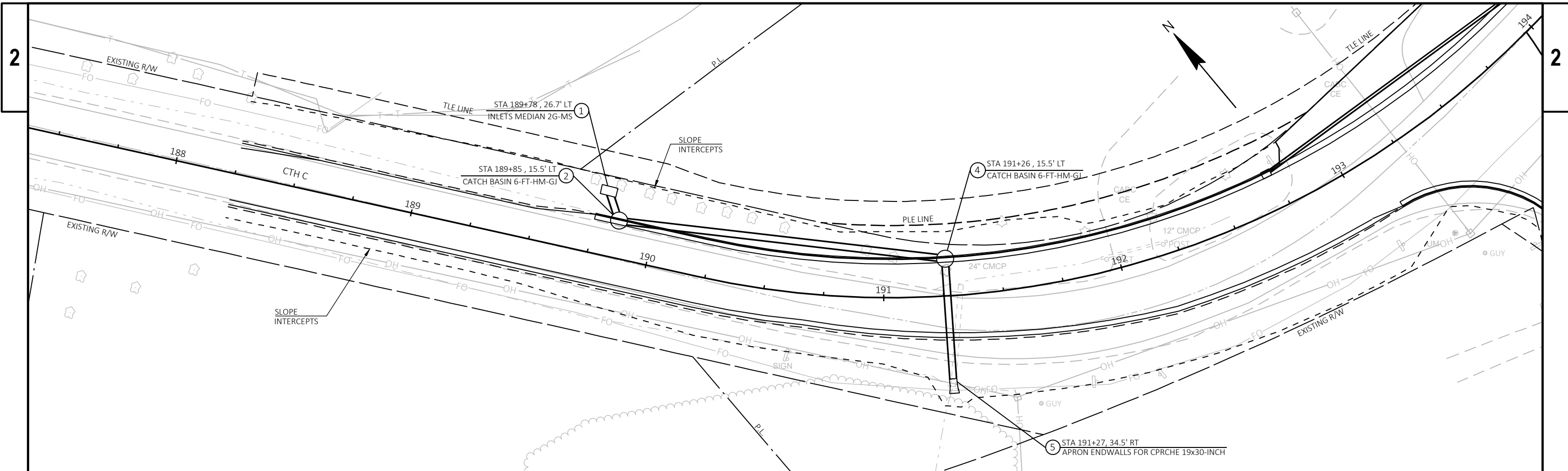

PROJECT NO: 4390-07-71

HWY: CTH C

COUNTY: KEWAUNEE

STORM SEWER PLAN

SHEET

E



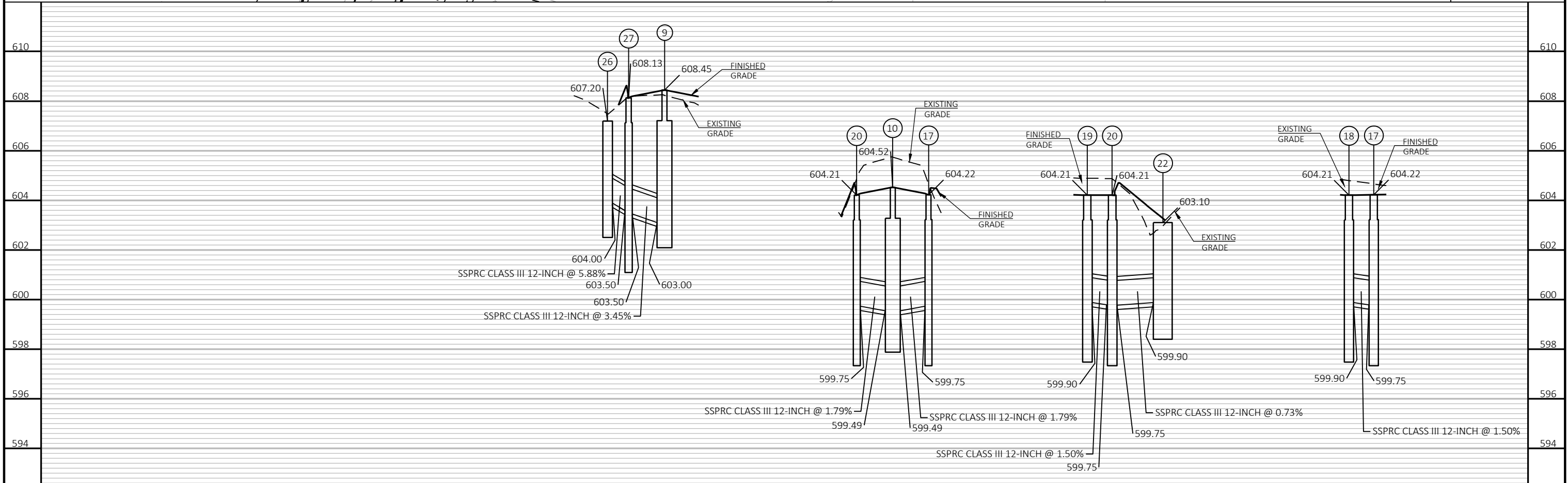
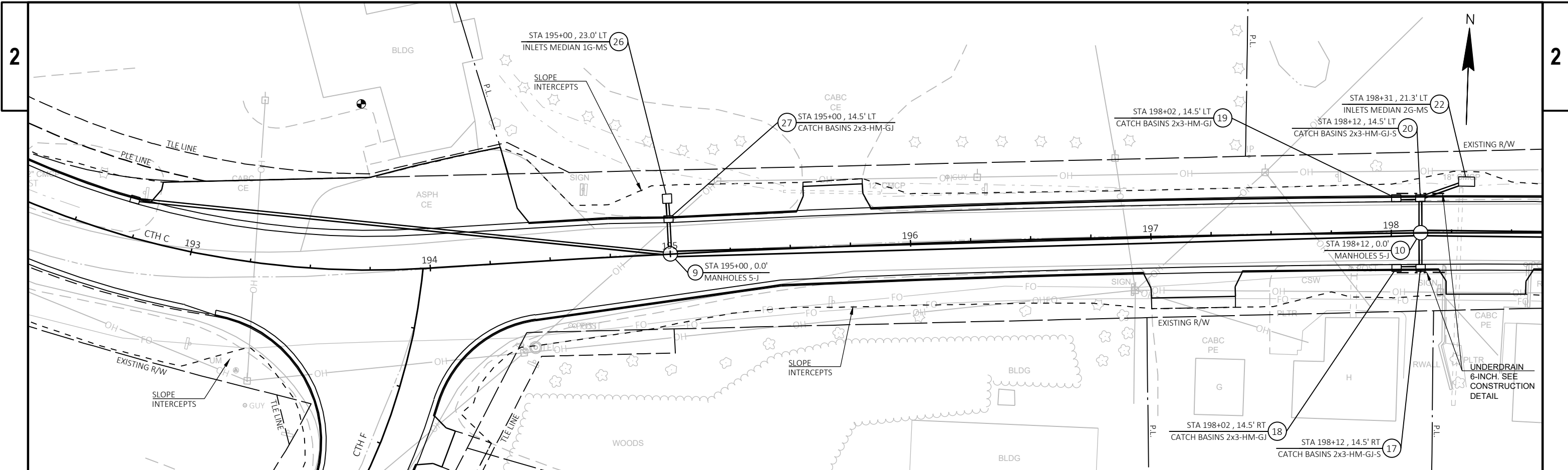

PROJECT NO: 4390-07-71	HWY: CTH C	COUNTY: KEWAUNEE	STORM SEWER PLAN	SHEET	E
------------------------	------------	------------------	------------------	-------	---

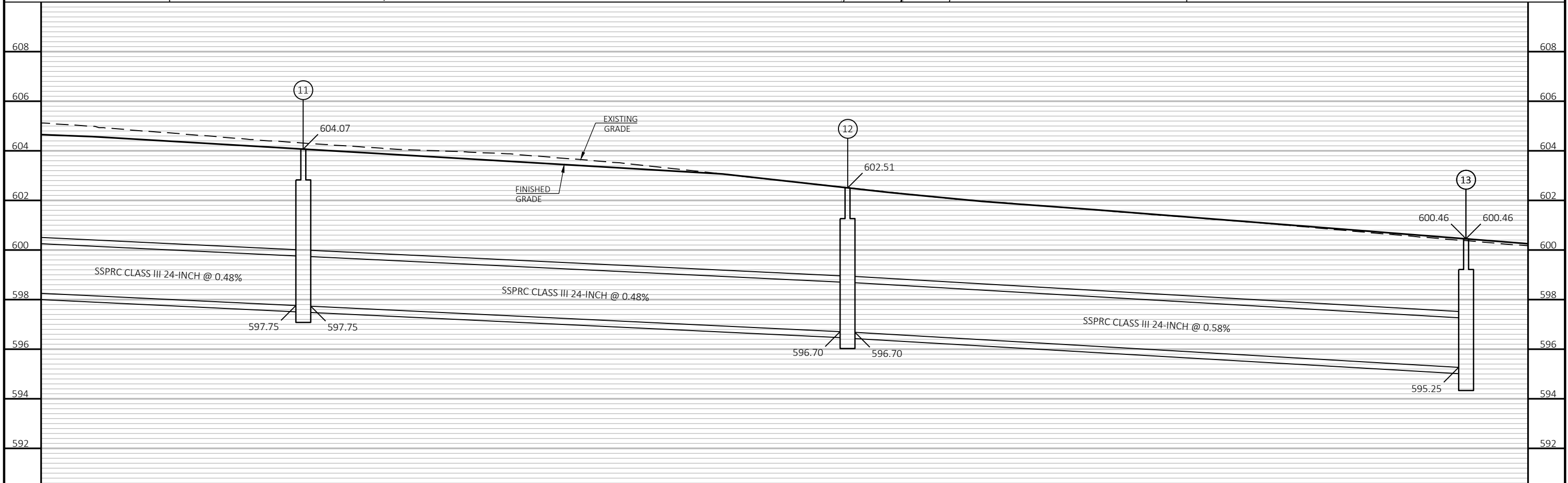
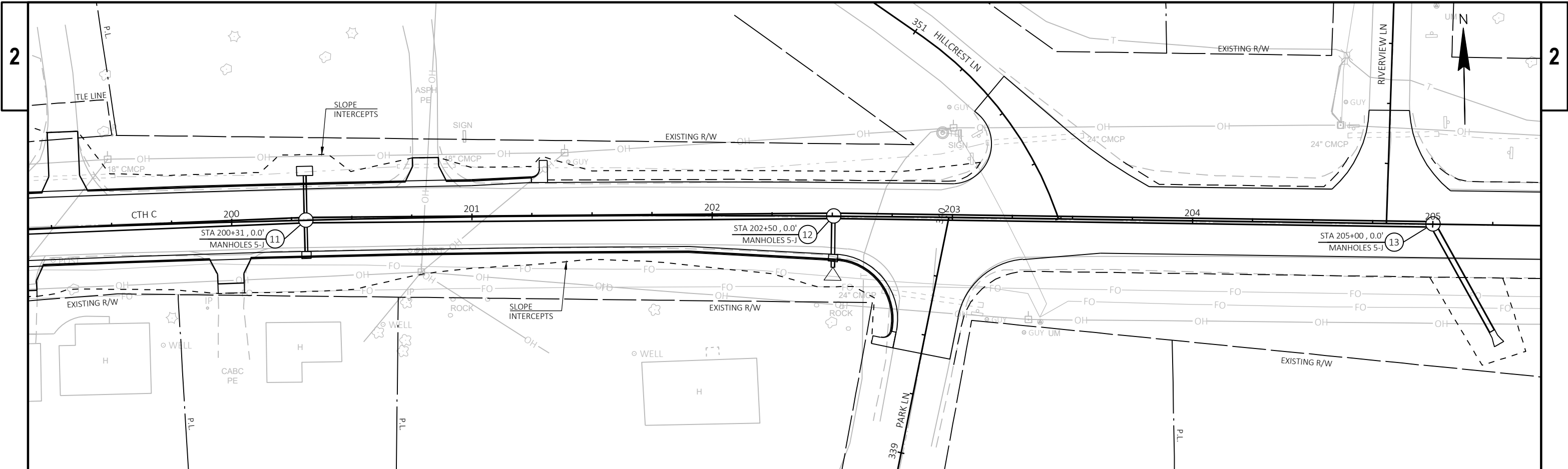

PROJECT NO: 4390-07-71	HWY: CTH C	COUNTY: KEWAUNEE	STORM SEWER PLAN	SHEET	<b>E</b>
------------------------	------------	------------------	------------------	-------	----------

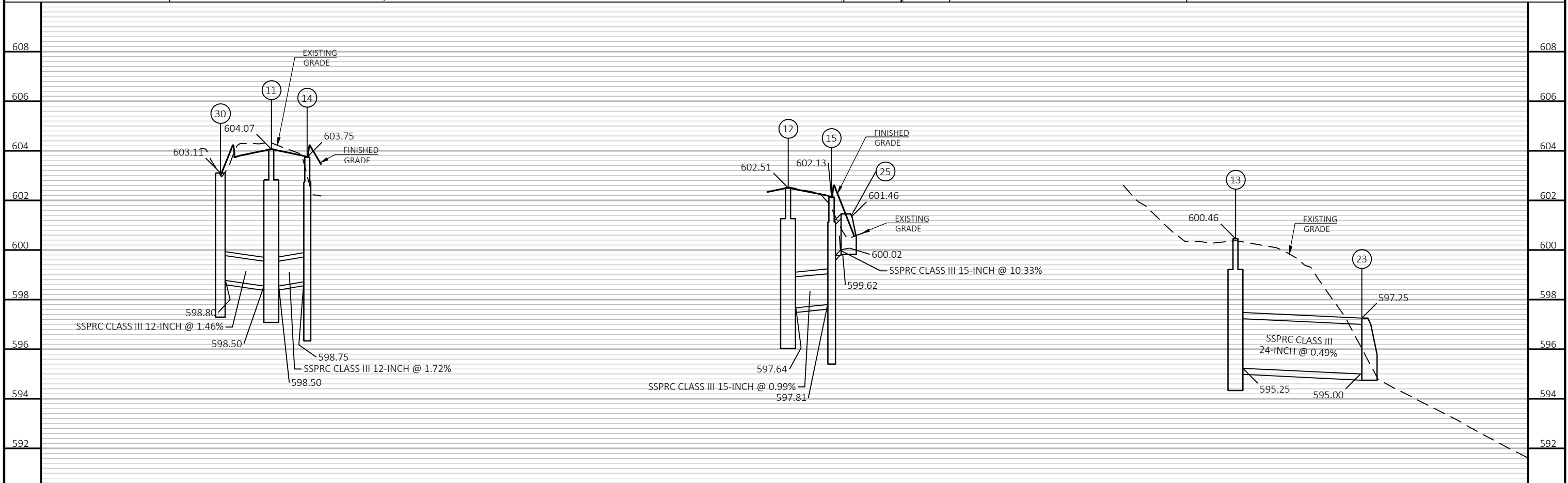
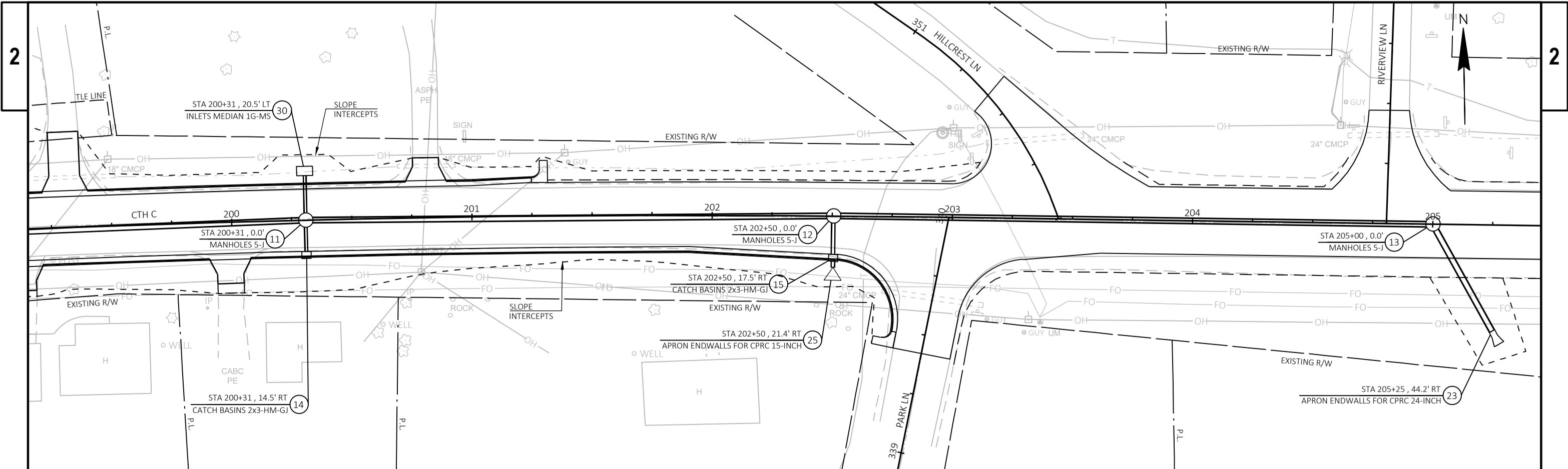

PROJECT NO: 4390-07-71	HWY: CTH C	COUNTY: KEWAUNEE	STORM SEWER PLAN	SHEET	<b>E</b>
------------------------	------------	------------------	------------------	-------	----------

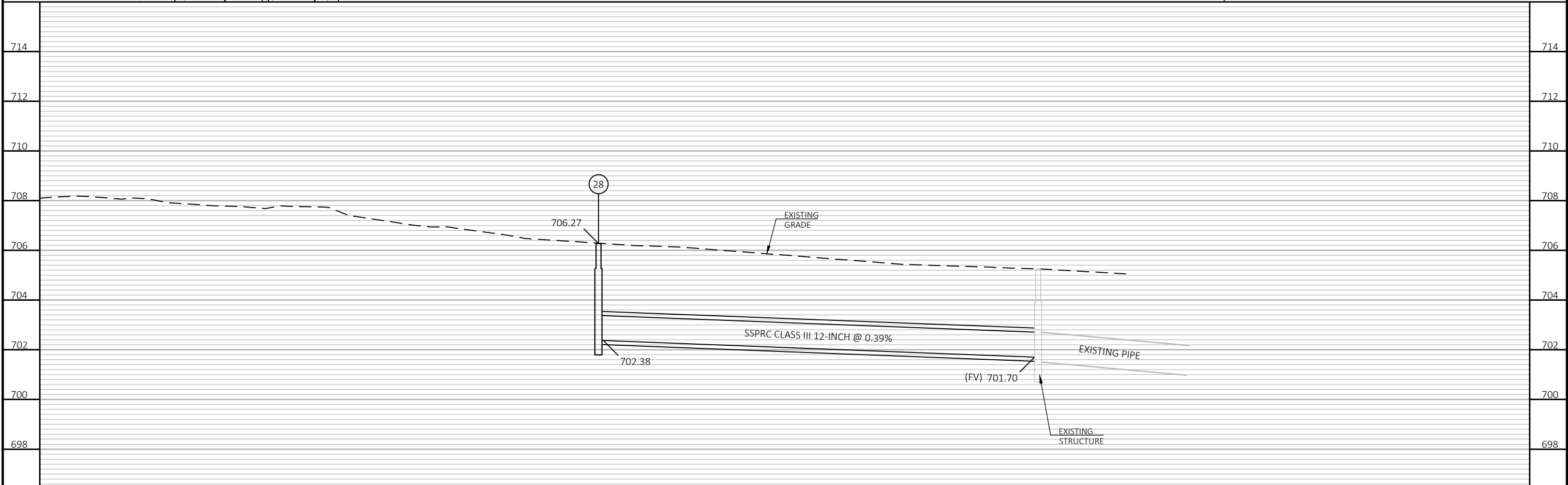
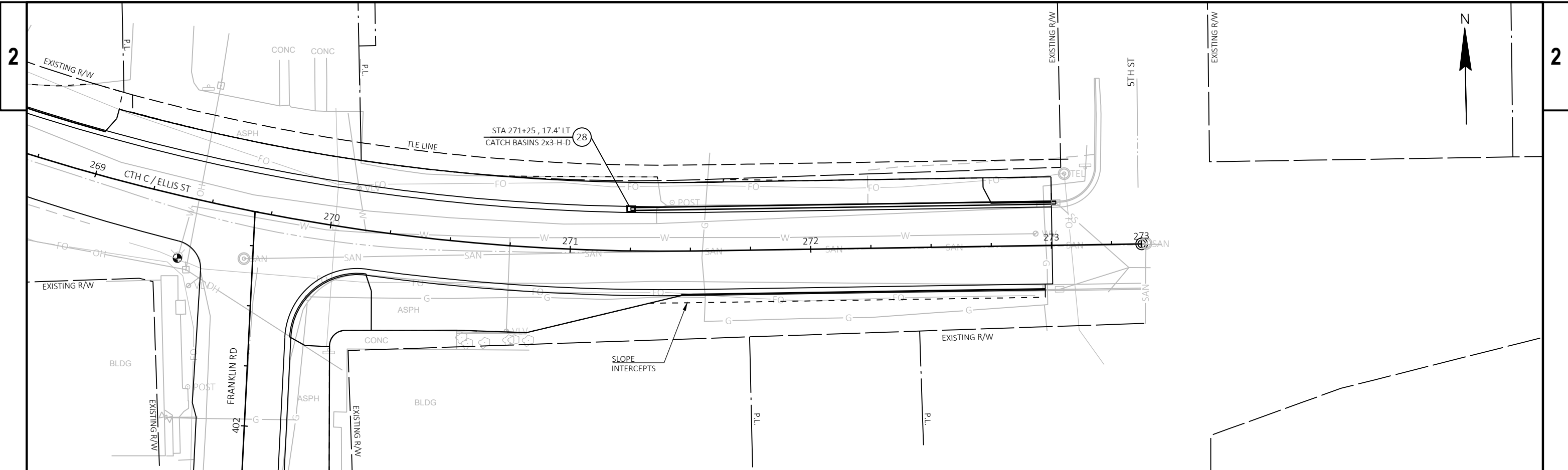

PROJECT NO: 4390-07-71	HWY: CTH C	COUNTY: KEWAUNEE	STORM SEWER PLAN	SHEET	<b>E</b>
------------------------	------------	------------------	------------------	-------	----------

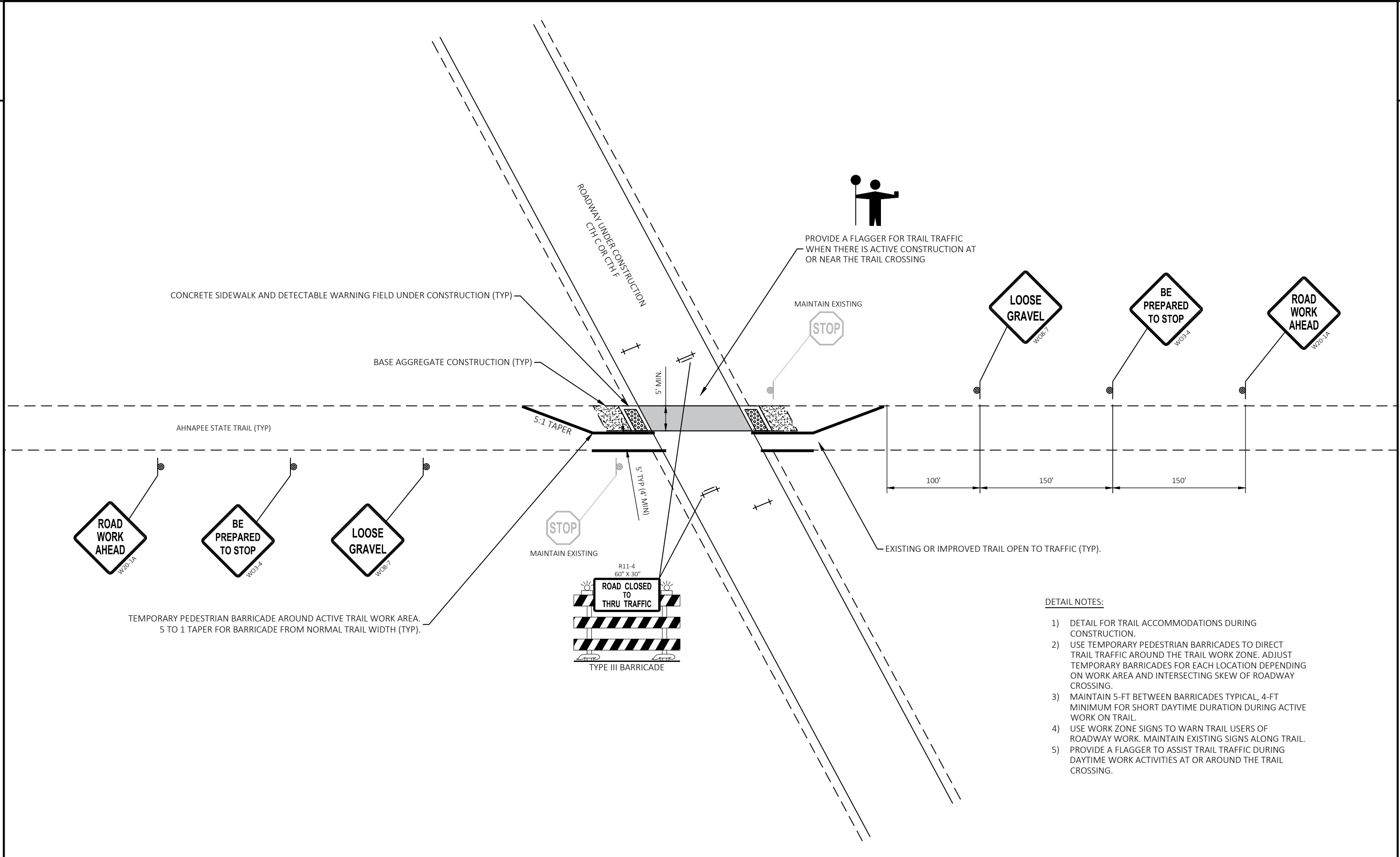

- DETAIL NOTES:**
- 1) DETAIL FOR TRAIL ACCOMMODATIONS DURING CONSTRUCTION.
  - 2) USE TEMPORARY PEDESTRIAN BARRICADES TO DIRECT TRAIL TRAFFIC AROUND THE TRAIL WORK ZONE. ADJUST TEMPORARY BARRICADES FOR EACH LOCATION DEPENDING ON WORK AREA AND INTERSECTING SKEW OF ROADWAY CROSSING.
  - 3) MAINTAIN 5-FT BETWEEN BARRICADES TYPICAL, 4-FT MINIMUM FOR SHORT DAYTIME DURATION DURING ACTIVE WORK ON TRAIL.
  - 4) USE WORK ZONE SIGNS TO WARN TRAIL USERS OF ROADWAY WORK. MAINTAIN EXISTING SIGNS ALONG TRAIL.
  - 5) PROVIDE A FLAGGER TO ASSIST TRAIL TRAFFIC DURING DAYTIME WORK ACTIVITIES AT OR AROUND THE TRAIL CROSSING.





- 1 M4-8 24"x12"
- 2 M1-5A 48"x48"
- 3 COUNTY C M1-5A 24"x24"
- 4 M5-1R 21"x21"
- 5 COUNTY C M1-5A 24"x24"
- 6 M6-1 21"x21"
- 7 COUNTY C M1-5A 24"x24"
- 8 COUNTY C M1-5A 24"x24"
- 9 M5-1L 21"x21"
- 10 COUNTY C M1-5A 24"x24"
- 11 M6-1 21"x21"

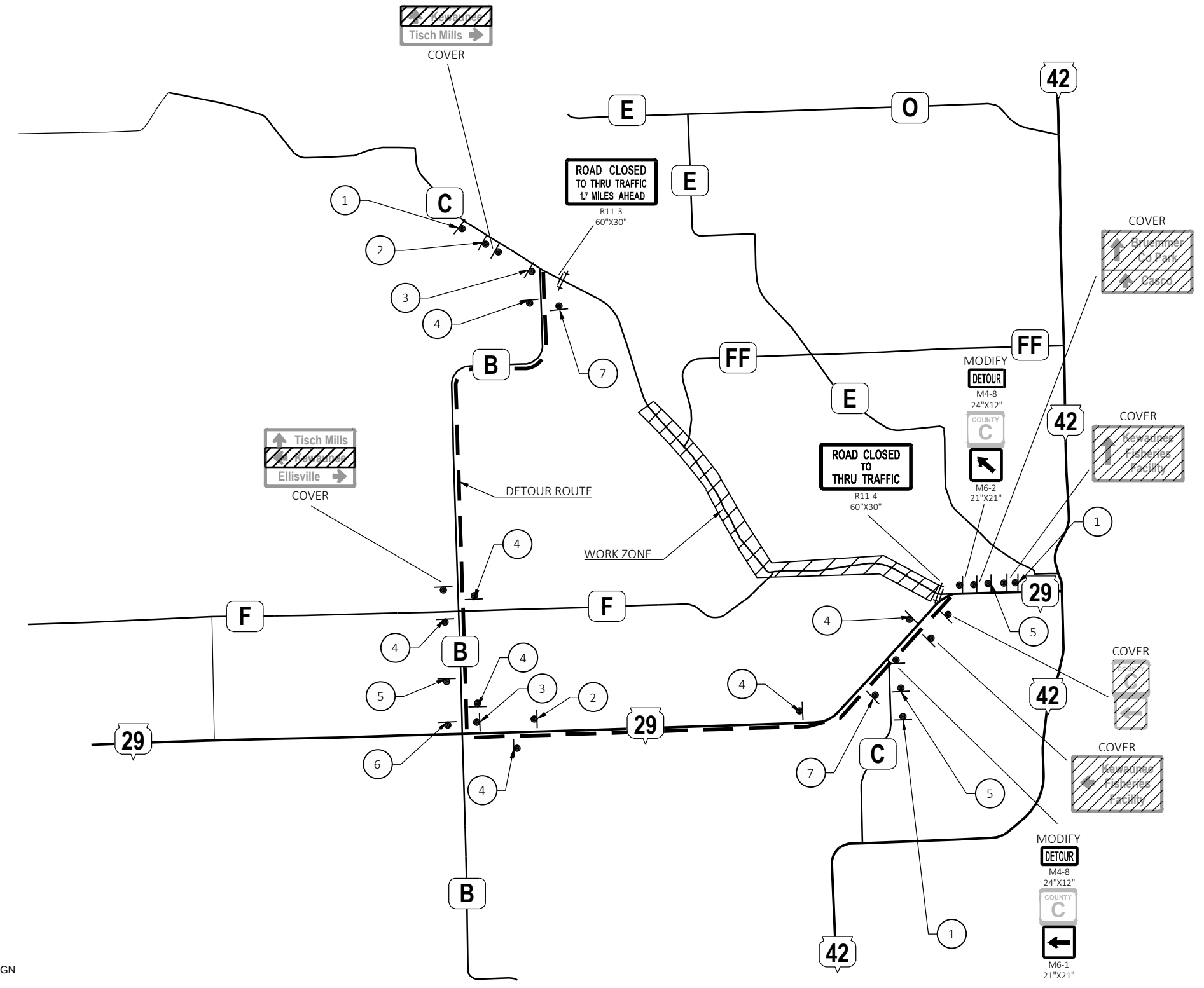

**LEGEND**

TYPE III BARRICADE WITH ATTACHED SIGN

SIGN ON PERMANENT SUPPORT

WORK AREA

DETOUR ROUTE

Estimate Of Quantities

4390-07-71

Line	Item	Item Description	Unit	Total	Qty
0002	201.0205	Grubbing	STA	5.000	5.000
0004	201.0220	Grubbing	ID	20.000	20.000
0006	203.0100	Removing Small Pipe Culverts	EACH	13.000	13.000
0008	203.0220	Removing Structure (structure) 01. 66x24 Box Culvert, Sta. 149+62	EACH	1.000	1.000
0010	203.0220	Removing Structure (structure) 02. 66x30 Box Culvert, Sta. 158+10	EACH	1.000	1.000
0012	204.0110	Removing Asphaltic Surface	SY	1,000.000	1,000.000
0014	204.0115	Removing Asphaltic Surface Butt Joints	SY	90.000	90.000
0016	204.0120	Removing Asphaltic Surface Milling	SY	32,250.000	32,250.000
0018	204.0150	Removing Curb & Gutter	LF	25.000	25.000
0020	204.0155	Removing Concrete Sidewalk	SY	6.000	6.000
0022	204.0190	Removing Surface Drains	EACH	2.000	2.000
0024	204.0270	Abandoning Culvert Pipes	EACH	1.000	1.000
0026	204.0291.S	Abandoning Sewer	CY	8.000	8.000
0028	205.0100	Excavation Common	CY	5,450.000	5,450.000
0030	208.0100	Borrow	CY	200.000	200.000
0032	211.0400	Prepare Foundation for Asphaltic Shoulders	STA	124.000	124.000
0034	213.0100	Finishing Roadway (project) 01. 4390-07-71	EACH	1.000	1.000
0036	305.0110	Base Aggregate Dense 3/4-Inch	TON	1,580.000	1,580.000
0038	305.0120	Base Aggregate Dense 1 1/4-Inch	TON	6,400.000	6,400.000
0040	310.0110	Base Aggregate Open-Graded	TON	12.000	12.000
0042	325.0100	Pulverize and Relay	SY	40,720.000	40,720.000
0044	374.1020.S	QMP Pulverize and Relay Compaction	SY	40,720.000	40,720.000
0046	416.0610	Drilled Tie Bars	EACH	4.000	4.000
0048	455.0605	Tack Coat	GAL	3,180.000	3,180.000
0050	460.2000	Incentive Density HMA Pavement	DOL	7,810.000	7,810.000
0052	460.5223	HMA Pavement 3 LT 58-28 S	TON	6,855.000	6,855.000
0054	460.5224	HMA Pavement 4 LT 58-28 S	TON	5,335.000	5,335.000
0056	465.0120	Asphaltic Surface Driveways and Field Entrances	TON	325.000	325.000
0058	465.0315	Asphaltic Flumes	SY	20.000	20.000
0060	520.1024	Apron Endwalls for Culvert Pipe 24-Inch	EACH	2.000	2.000
0062	520.1030	Apron Endwalls for Culvert Pipe 30-Inch	EACH	2.000	2.000
0064	521.0657	Apron Endwalls for Pipe Arch Sloped Cross Drains Steel 57x38-Inch 6 to 1	EACH	3.000	3.000
0066	521.1228	Apron Endwalls for Pipe Arch Steel 28x20-Inch	EACH	4.000	4.000
0068	521.1257	Apron Endwalls for Pipe Arch Steel 57x38-Inch	EACH	4.000	4.000
0070	521.3728	Pipe Arch Corrugated Steel 28x20-Inch	LF	104.000	104.000
0072	521.3757	Pipe Arch Corrugated Steel 57x38-Inch	LF	86.000	86.000
0074	522.1015	Apron Endwalls for Culvert Pipe Reinforced Concrete 15-Inch	EACH	1.000	1.000
0076	522.1024	Apron Endwalls for Culvert Pipe Reinforced Concrete 24-Inch	EACH	1.000	1.000
0078	522.2338	Culvert Pipe Reinforced Concrete Horizontal Elliptical Class HE-III 38x60-Inch	LF	36.000	36.000
0080	522.2429	Culvert Pipe Reinforced Concrete Horizontal Elliptical Class HE-IV 29x45-Inch	LF	76.000	76.000
0082	522.2619	Apron Endwalls for Culvert Pipe Reinforced Concrete Horizontal Elliptical 19x30-Inch	EACH	1.000	1.000
0084	522.2629	Apron Endwalls for Culvert Pipe Reinforced Concrete Horizontal Elliptical 29x45-Inch	EACH	4.000	4.000
0086	522.2638	Apron Endwalls for Culvert Pipe Reinforced Concrete Horizontal Elliptical 38x60-Inch	EACH	2.000	2.000
0088	530.0124	Culvert Pipe Corrugated Polyethylene 24-Inch	LF	74.000	74.000
0090	530.0130	Culvert Pipe Corrugated Polyethylene 30-Inch	LF	86.000	86.000
0092	601.0411	Concrete Curb & Gutter 30-Inch Type D	LF	915.000	915.000
0094	601.0415	Concrete Curb & Gutter 6-Inch Sloped 30-Inch Type J	LF	2,195.000	2,195.000
0096	601.0584	Concrete Curb & Gutter 4-Inch Sloped 30-Inch Type TBT	LF	94.000	94.000
0098	602.0415	Concrete Sidewalk 6-Inch	SF	860.000	860.000
0100	602.0515	Curb Ramp Detectable Warning Field Natural Patina	SF	414.000	414.000

Estimate Of Quantities

4390-07-71

Line	Item	Item Description	Unit	Total	Qty
0102	602.3010	Concrete Surface Drains	CY	4.000	4.000
0104	606.0200	Riprap Medium	CY	80.000	80.000
0106	608.0312	Storm Sewer Pipe Reinforced Concrete Class III 12-Inch	LF	522.000	522.000
0108	608.0315	Storm Sewer Pipe Reinforced Concrete Class III 15-Inch	LF	20.000	20.000
0110	608.0324	Storm Sewer Pipe Reinforced Concrete Class III 24-Inch	LF	1,050.000	1,050.000
0112	608.2319	Storm Sewer Pipe Reinforced Concrete Horizontal Elliptical Class HE-III 19x30-Inch	LF	150.000	150.000
0114	608.2419	Storm Sewer Pipe Reinforced Concrete Horizontal Elliptical Class HE-IV 19x30-Inch	LF	50.000	50.000
0116	611.0535	Manhole Covers Type J-Special	EACH	5.000	5.000
0118	611.0630	Inlet Covers Type HM-GJ	EACH	8.000	8.000
0120	611.0633	Inlet Covers Type HM-GJ-S	EACH	2.000	2.000
0122	611.0642	Inlet Covers Type MS	EACH	6.000	6.000
0124	611.1006	Catch Basins 6-FT Diameter	EACH	2.000	2.000
0126	611.1230	Catch Basins 2x3-FT	EACH	9.000	9.000
0128	611.2005	Manholes 5-FT Diameter	EACH	5.000	5.000
0130	611.3901	Inlets Median 1 Grate	EACH	2.000	2.000
0132	611.3902	Inlets Median 2 Grate	EACH	2.000	2.000
0134	611.9850.S	Pipe Grates (size) 01. 29x45-Inch	EACH	4.000	4.000
0136	611.9850.S	Pipe Grates (size) 02. 38x60-Inch	EACH	2.000	2.000
0138	612.0106	Pipe Underdrain 6-Inch	LF	40.000	40.000
0140	614.0920	Salvaged Rail	LF	1,853.000	1,853.000
0142	614.2300	MGS Guardrail 3	LF	1,106.300	1,106.300
0144	614.2330	MGS Guardrail 3 K	LF	150.000	150.000
0146	614.2350	MGS Guardrail Short Radius	LF	24.700	24.700
0148	614.2500	MGS Thrie Beam Transition	LF	315.200	315.200
0150	614.2610	MGS Guardrail Terminal EAT	EACH	10.000	10.000
0152	614.2630	MGS Guardrail Short Radius Terminal	EACH	2.000	2.000
0154	619.1000	Mobilization	EACH	1.000	1.000
0156	624.0100	Water	MGAL	385.000	385.000
0158	625.0100	Topsoil	SY	7,400.000	7,400.000
0160	628.1504	Silt Fence	LF	2,800.000	2,800.000
0162	628.1520	Silt Fence Maintenance	LF	5,600.000	5,600.000
0164	628.1905	Mobilizations Erosion Control	EACH	5.000	5.000
0166	628.1910	Mobilizations Emergency Erosion Control	EACH	4.000	4.000
0168	628.2004	Erosion Mat Class I Type B	SY	450.000	450.000
0170	628.2008	Erosion Mat Urban Class I Type B	SY	6,950.000	6,950.000
0172	628.2027	Erosion Mat Class II Type C	SY	170.000	170.000
0174	628.7005	Inlet Protection Type A	EACH	15.000	15.000
0176	628.7010	Inlet Protection Type B	EACH	4.000	4.000
0178	628.7015	Inlet Protection Type C	EACH	13.000	13.000
0180	628.7555	Culvert Pipe Checks	EACH	60.000	60.000
0182	628.7570	Rock Bags	EACH	116.000	116.000
0184	629.0210	Fertilizer Type B	CWT	5.000	5.000
0186	630.0120	Seeding Mixture No. 20	LB	60.000	60.000
0188	630.0140	Seeding Mixture No. 40	LB	90.000	90.000
0190	630.0500	Seed Water	MGAL	170.000	170.000
0192	642.5001	Field Office Type B	EACH	1.000	1.000
0194	643.0300	Traffic Control Drums	DAY	600.000	600.000
0196	643.0420	Traffic Control Barricades Type III	DAY	5,800.000	5,800.000
0198	643.0705	Traffic Control Warning Lights Type A	DAY	11,400.000	11,400.000
0200	643.0900	Traffic Control Signs	DAY	11,300.000	11,300.000

Estimate Of Quantities

4390-07-71

Line	Item	Item Description	Unit	Total	Qty
0202	643.0920	Traffic Control Covering Signs Type II	EACH	8.000	8.000
0204	643.1050	Traffic Control Signs PCMS	DAY	14.000	14.000
0206	643.5000	Traffic Control	EACH	1.000	1.000
0208	644.1810	Temporary Pedestrian Barricade	LF	1,550.000	1,550.000
0210	645.0111	Geotextile Type DF Schedule A	SY	28.000	28.000
0212	645.0120	Geotextile Type HR	SY	220.000	220.000
0214	646.1020	Marking Line Epoxy 4-Inch	LF	48,060.000	48,060.000
0216	646.3020	Marking Line Epoxy 8-Inch	LF	100.000	100.000
0218	648.0100	Locating No-Passing Zones	MI	3.050	3.050
0220	650.4000	Construction Staking Storm Sewer	EACH	23.000	23.000
0222	650.4500	Construction Staking Subgrade	LF	2,107.000	2,107.000
0224	650.5000	Construction Staking Base	LF	2,107.000	2,107.000
0226	650.5500	Construction Staking Curb Gutter and Curb & Gutter	LF	3,200.000	3,200.000
0228	650.6000	Construction Staking Pipe Culverts	EACH	9.000	9.000
0230	650.8000	Construction Staking Resurfacing Reference	LF	14,376.000	14,376.000
0232	650.9500	Construction Staking Sidewalk (project) 01. 4790-07-71	EACH	1.000	1.000
0234	650.9911	Construction Staking Supplemental Control (project) 01. 4790-07-71	EACH	1.000	1.000
0236	650.9920	Construction Staking Slope Stakes	LF	3,107.000	3,107.000
0238	690.0150	Sawing Asphalt	LF	740.000	740.000
0240	690.0250	Sawing Concrete	LF	13.000	13.000
0242	740.0440	Incentive IRI Ride	DOL	24,384.000	24,384.000
0244	ASP.1T0A	On-the-Job Training Apprentice at \$5.00/HR	HRS	2,000.000	2,000.000
0246	ASP.1T0G	On-the-Job Training Graduate at \$5.00/HR	HRS	1,320.000	1,320.000
0248	SPV.0035	Special 01. Foundation Backfill	CY	755.000	755.000
0250	SPV.0060	Special 01. Inlet Covers Type H-D	EACH	1.000	1.000
0252	SPV.0180	Special 01. Protective Polymer Coating at Snowmobile Trail Crossing	SY	412.000	412.000

3

GRUBBING

CATEGORY	STATION	TO	STATION	LOCATION	201.0205	201.0220	REMARKS
					GRUBBING	GRUBBING	
					STA	ID	
0010	150+60			CTH C, LT	-	20	BY CULVERT 102
0010	189+70	-	192+60	CTH C, LT	3	-	GRADING BY CURVE
0010	235+50	-	237+00	CTH C, LT	2	-	GRADING AT GUARD RAIL
TOTAL 0010					5	20	

REMOVING SMALL CULVERTS AND STRUCTURES

CATEGORY	STATION	LOCATION	203.0100	203.0220.01	203.0220.02	REMARKS
			REMOVING SMALL PIPE CULVERTS	REMOVING STRUCTURE 66x24 BOX CULVERT STA. 149+62	REMOVING STRUCTURE 66x30 BOX CULVERT STA. 158+10	
			EACH	EACH	EACH	
0010	119+70	CTH C	1	-	-	18" CMCP
0010	119+83	CTH C, RT	1	-	-	57 X 38 CMCP
0010	120+31	CTH C, RT	1	-	-	57 X 38 CMCP
0010	127+01	CTH C	1	-	-	30" CMCP
0010	149+62	CTH C	-	1	-	66 X 24 BOX CULVERT
0010	158+10	CTH C	-	-	1	66 X 30 BOX CULVERT
0010	191+29	CTH C	1	-	-	24" CMCP
0010	192+06	CTH C, LT	1	-	-	12" CMCP
0010	195+68	CTH C, LT	1	-	-	12" CMCP
0010	198+28	CTH C	1	-	-	18" CMCP
0010	198+95	CTH C, LT	1	-	-	12" CMCP
0010	199+16	CTH C, LT	1	-	-	18" CMCP
0010	200+80	CTH C, LT	1	-	-	18" CMCP
0010	202+95	CTH C, RT	1	-	-	24" CMCP
0010	205+68	CTH C	1	-	-	24" CMCP
TOTAL 0010			13	1	1	

ABANDONING CULVERT PIPES

CATEGORY	STATION	LOCATION	204.0270
			ABANDONING CULVERT PIPES
			EACH
0010	198+28	CTH C, RT	1
TOTAL 0010			1

REMOVING ASPHALTIC SURFACES

CATEGORY	STATION	TO	STATION	LOCATION	204.0110	204.0115	REMARKS
					REMOVING ASPHALTIC SURFACE SY	REMOVING ASPHALTIC SURFACE BUTT JOINTS SY	
0010	109+25			CTH C	-	6	BOP
0010	298+98			CTH L	-	6	
0010	121+97			CTH C	-	8	BRIDGE APPROACH
0010	123+35			CTH C	-	8	BRIDGE APPROACH
0010	121+10	-	121+50	CTH C, RT	130	-	DRIVEWAY
0010	310+80			CTH FF	-	8	
0010	142+00	-	146+00	CTH C, RT	90	-	DRIVEWAYS
0010	320+30			GRANDVIEW LN	-	6	
0010	194+35	-	194+65	CTH C, LT	50	-	DRIVEWAY/PARKING
0010	339+42			PARK LN	-	6	
0010	350+60			HILLCREST LN	-	4	
0010	350+45			RIVERVIEW LN	-	4	
0010	209+67			CTH C	-	10	BRIDGE APPROACH
0010	211+11			CTH C	-	10	BRIDGE APPROACH
0010	268+40	-	271+35	CTH C, LT	330	-	DRIVEWAY/PARKING
0010	269+88	-	271+40	CTH C, RT	400	-	DRIVEWAY/PARKING
0010	273+00			CTH C	-	7	EOP
0010	401+29			FRANKLIN RD	-	7	
TOTAL 0010					1,000	90	

REMOVING ASPHALTIC SURFACE MILLING

CATEGORY	STATION	TO	STATION	LOCATION	204.0120	REMARKS
					REMOVING ASPHALTIC SURFACE MILLING SY	
0010	109+25	-	121+97	CTH C	3,540	
0010	298+95	-	299+85	CTH L	760	INTERSECTION APPROACH
0010	310+24	-	310+80	CTH FF	390	INTERSECTION APPROACH
0010	123+35	-	132+00	CTH C	3,880	INCLUDES WIDER PAVEMENT BY CTH FF
0010	132+00	-	157+25	CTH C	6,460	
0010	165+50	-	180+00	CTH C	3,740	INCLUDES SIDE ROAD APPROACHES
0010	180+00	-	189+75	CTH C	2,500	
0010	202+78	-	209+67	CTH C	2,510	INCLUDES SIDE ROAD APPROACHES
0010	211+11	-	216+00	CTH C	1,580	INCLUDES MILL TRANSITION
0010	234+00	-	245+50	CTH C	3,710	INCLUDES MILL TRANSITIONS
0010	266+25	-	273+00	CTH C	2,630	INCLUDES MILL TRANSITION
0010	401+29	-	402+70	FRANKLIN RD	550	
TOTAL 0010					32,250	

3

**EARTHWORK SUMMARY**

Division	From/To Station	Location	Excavation Common (1) (item #205.0100)		Unexpanded Fill (4)	Expanded Fill Factor 1.30	Mass Ordinate +/- (5)	Foundation Backfill (Item # SPV.0035.01)	Waste	Borrow (item # 208.0100)
			Cut	EBS (2)						
1	157+25 to 165+50	CTH C	1,260		37	48	1,212	0	1,212	0
	188+75 to 202+78	CTH C	2,611		62	81	2,530	0	2,530	0
	327+71 to 329+50	CTH F	109		5	7	103	0	103	0
	UNDISTRIBUTED		-	120	-	-	-	-	-	-
2	120+25 LT - 121+75 LT	CTH C GUARDRAIL	46		16	20	25	0	25	0
	123+50 RT - 124+52 RT	CTH C GUARDRAIL	33		19	24	9	0	9	0
3	207+25 RT - 209+50 RT	CTH C GUARDRAIL	69		19	24	45	0	45	0
	211+50 RT - 212+72 RT	CTH C GUARDRAIL	30		6	8	22	0	22	0
4	235+84 LT - 237+86 LT	CTH C GUARDRAIL	24		169	220	-196	0	-196	196
	242+69 RT - 244+00 RT	CTH C GUARDRAIL	18		17	22	-4	0	-4	4
5	119+18 - 119+70	CTH C CULVERT	120		-	-	-	60	120	0
	126+55 - 127+45	CTH C CULVERT	280		-	-	-	200	280	0
	150+40 - 141+10	CTH C CULVERT	200		-	-	-	120	200	0
	157+70 - 158+50	CTH C CULVERT	245		-	-	-	175	245	0
	205+21 - 206+15	CTH C CULVERT	285		-	-	-	200	285	0
Totals			5,330	120	349	453	3,746	755	4,876	200
<b>Total Common Excavation</b>			5,450							

- 1) Common Excavation is the sum of the Cut and EBS Excavation columns. Item number 205.0100.
- 2) EBS Excavation to be backfilled with Base Aggregate Dense 1 1/4-inch, Item 305.0120.
- 4) Fill areas to be backfilled with cut material from the roadway.
- 5) Mass Ordinate = Cut + EBS - Expanded Fill. The Mass Ordinate + or - Qty calculated for the Division. Plus quantity indicates an excess of material within the Division. Minus indicates a shortage of material within the Division.

3

3

REMOVING CONCRETE

CATEGORY	STATION TO STATION	LOCATION	204.0150	204.0155
			REMOVING CURB & GUTTER LF	REMOVING CONCRETE SIDEWALK SY
0010	197+82	CTH C, RT	-	6
0010	272+94 - 273+01	CTH C, LT	7	-
0010	272+98 - 273+00	CTH C, RT	2	-
0010	401+29 - 401+45	FRANKLIN RD	16	-
TOTAL 0010			25	6

REMOVING SURFACE DRAINS AND ABANDONING SEWER

CATEGORY	STATION	LOCATION	204.0190	204.0291.S
			REMOVING SURFACE DRAINS EACH	ABANDONING SEWER CY
0010	211+20	CTH C, RT	1	4
0010	211+35	CTH C, LT	1	4
TOTAL 0010			2	8

PREPARE FOUNDATION FOR ASPHALTIC SHOULDERS

CATEGORY	STATION TO STATION	LOCATION	211.0400
			PREPARE FOUNDATION FOR ASPHALTIC SHOULDERS STA
0010	109+25 - 120+75	CTH C, LT	12
0010	111+75 - 120+75	CTH C, RT	9
0010	132+00 - 157+25	CTH C, LT	26
0010	132+00 - 157+25	CTH C, RT	26
0010	165+50 - 189+75	CTH C, LT	25
0010	165+50 - 189+75	CTH C, RT	25
0010	267+25 - 268+25	CTH C, LT	1
TOTAL 0010			124

BASE AGGREGATE

CATEGORY	STATION TO STATION	LOCATION	305.0110	305.0120	624.0100	REMARKS
			BASE AGGREGATE DENSE 3/4-INCH TON	BASE AGGREGATE DENSE 1 1/4-INCH TON	WATER MGAL	
0010	109+25 - 120+00	CTH C, LT	50	-	0.5	
0010	109+25 - 121+00	CTH C, RT	54	-	0.5	
0010	120+50 - 121+90	CTH C, LT	16	72	0.9	GUARD RAIL EAT GRADING
0010	121+40 - 122+09	CTH C, RT	8	-	0.1	
0010	123+25 - 126+20	CTH C, LT	34	-	0.3	
0010	123+40 - 124+60	CTH C, RT	14	66	0.8	GUARD RAIL EAT GRADING
0010	126+20 - 157+25	CTH C, LT	142	-	1.4	
0010	157+25 - 165+50	CTH C	76	1508	15.8	RECONSTRUCTION AREA
0010	124+60 - 157+25	CTH C, RT	150	-	1.5	
0010	165+50 - 189+75	CTH C, LT	111	-	1.1	
0010	165+50 - 189+75	CTH C, RT	111	-	1.1	
0010	189+75 - 196+00	CTH C	-	1357	13.6	
0010	189+75 - 193+15	CTH C, RT	16	233	2.5	RIGHT TURN LANE AT CTH F
0010	327+71 - 329+76	CTH F	10	410	4.2	INCLUDES TRAIL
0010	196+00 - 203+00	CTH C	8	1399	14.1	
0010	203+90 - 208+90	CTH C, LT	23	-	0.2	
0010	203+00 - 207+75	CTH C, RT	22	-	0.2	
0010	208+90 - 209+72	CTH C, LT	8	10	0.2	GUARD RAIL EAT GRADING
0010	207+75 - 209+60	CTH C, RT	17	64	0.8	GUARD RAIL EAT GRADING
0010	211+28 - 214+00	CTH C, LT	32	13	0.5	CURB & GUTTER, GUARD RAIL EAT GRADING
0010	211+14 - 212+55	CTH C, RT	17	41	0.6	CURB & GUTTER, GUARD RAIL EAT GRADING
0010	214+00 - 235+50	CTH C, LT	99	-	1.0	
0010	212+55 - 237+00	CTH C, RT	112	-	1.1	
0010	235+50 - 244+00	CTH C, LT	98	69	1.7	GUARD RAIL EAT GRADING
0010	237+00 - 244+00	CTH C, RT	80	92	1.7	GUARD RAIL EAT GRADING
0010	244+00 - 268+25	CTH C, LT	111	-	1.1	
0010	244+00 - 269+00	CTH C, RT	115	-	1.2	
0010	268+20 - 273+00	CTH C, LT	-	74	0.7	CURB & GUTTER
0010	269+90 - 273+00	CTH C, RT	-	48	0.5	CURB & GUTTER
0010	401+30 - 402+60	FRANKLIN RD, RT	-	20	0.2	CURB & GUTTER
0010	161+00 - 161+75	CTH C, LT	21	-	0.2	TRAIL
0010	162+00 - 163+00	CTH C, RT	8	-	0.1	TRAIL
0010	225+00 - 226+00	CTH C, RT	5	-	0.1	TRAIL
0010	226+50 - 227+50	CTH C, LT	12	-	0.1	TRAIL
0010	119+18 - 119+70	CTH C	-	111	1.1	CULVERT TRANSITION
0010	126+55 - 127+45	CTH C	-	148	1.5	CULVERT TRANSITION
0010	150+40 - 151+10	CTH C	-	148	1.5	CULVERT TRANSITION
0010	157+70 - 158+50	CTH C	-	130	1.3	CULVERT TRANSITION
0010	205+21 - 206+15	CTH C	-	157	1.6	CULVERT TRANSITION
UNDISTRIBUTED			-	230	2.4	EBS AREAS
UNDISTRIBUTED			-	-	60.0	DUST CONTROL
TOTAL 0010			1,580	6,400	140.0	

\* ADDITIONAL QUANTITIES SHOWN ELSEWHERE

PULVEIZE AND RELAY

CATEGORY	STATION	TO	STATION	LOCATION	325.0100	374.1020.S	624.0100	REMARKS
					PULVERIZE AND RELAY SY	QMP PULVERIZE AND RELAY COMPACTION SY	WATER MGAL	
0010	109+25	-	121+97	CTH C	3,540	3,540	21	
0010	123+35	-	132+00	CTH C	3,880	3,880	23	INCLUDES WIDER PAVEMENT BY CTH FF
0010	132+00	-	157+25	CTH C	6,460	6,460	39	
0010	165+50	-	180+00	CTH C	3,710	3,710	22	
0010	180+00	-	189+75	CTH C	2,500	2,500	15	
0010	202+78	-	209+67	CTH C	2,230	2,230	13	
0010	211+11	-	216+00	CTH C	1,580	1,580	10	
0010	216+00	-	225+00	CTH C	2,300	2,300	14	
0010	225+00	-	234+00	CTH C	2,300	2,300	14	
0010	234+00	-	245+50	CTH C	3,710	3,710	22	
0010	245+50	-	255+00	CTH C	2,430	2,430	15	
0010	255+00	-	266+25	CTH C	2,880	2,880	17	
0010	266+25	-	273+00	CTH C	2,630	2,630	16	
0010	401+29	-	402+70	FRANKLIN RD	570	570	4	
TOTAL 0010					40,720	40,720	245	

\* ADDITIONAL QUANTITIES SHOWN ELSEWHERE

ASPHALTIC SURFACE

465.0120  
ASPHALTIC SURFACE  
DRIVEWAYS AND  
FIELD ENTRANCES

CATEGORY	STATION	TO	STATION	LOCATION	TON	REMARKS
0010	121+11			CTH C, RT	20	
0010	142+00	-	146+00	CTH C, RT	10	MULTIPLE DRIVEWAYS
0010	192+82	-	194+40	CTH C, LT	54	
0010	195+50	-	200+90	CTH C, LT	17	MULTIPLE DRIVEWAYS
0010	196+90	-	200+15	CTH C, RT	23	MULTIPLE DRIVEWAYS
0010	327+80	-	329+75	CTH F, RT	19	MULTIPLE DRIVEWAYS
0010	208+50	-	209+10	CTH C, LT	8	
0010	232+00	-	232+60	CTH C, RT	10	
0010	260+75	-	263+00	CTH C	18	MULTIPLE DRIVEWAYS
0010	269+00	-	273+00	CTH C, LT	77	DRIVEWAYS AND TERRACES
0010	269+88	-	271+35	CTH C, RT	69	DRIVEWAYS AND TERRACES
TOTAL 0010					325	

HMA PAVEMENT

455.0605      460.5223      460.5224  
TACK COAT      HMA PAVEMENT      HMA PAVEMENT  
                         3 LT 58-28 S      4 LT 58-28 S

CATEGORY	STATION	TO	STATION	LOCATION	GAL	TON	TON	REMARKS
0010	109+25	-	121+97	CTH C	238	512	399	
0010	298+95	-	299+85	CTH L	46	99	77	INTERSECTION APPROACH
0010	310+24	-	310+80	CTH FF	28	61	47	INTERSECTION APPROACH
0010	123+35	-	135+50	CTH C	227	490	381	
0010	135+50	-	157+25	CTH C	377	813	633	
0010	157+25	-	165+50	CTH C	148	318	247	INCLUDES WIDER SHOULDER BY TRAIL
0010	165+50	-	180+00	CTH C	252	542	422	
0010	320+13	-	320+35	GRANDVIEW LN	4	8	6	INTERSECTION APPROACH
0010	180+00	-	189+75	CTH C	169	365	284	
0010	189+75	-	196+00	CTH C	112	243	189	
0010	190+65	-	195+45	CTH C, RT	29	63	49	TURN LANE AT CTH F
0010	327+71	-	329+75	CTH F	41	88	69	
0010	196+00	-	202+00	CTH C	104	225	175	
0010	339+42	-	339+86	PARK LANE	14	29	23	INTERSECTION APPROACH
0010	202+00	-	208+00	CTH C	112	242	188	
0010	350+60	-	350+14	HILLCREST LN	11	24	19	INTERSECTION APPROACH
0010	360+45	-	360+14	RIVERVIEW LN	7	14	11	INTERSECTION APPROACH
0010	208+00	-	209+67	CTH C	40	87	68	
0010	211+11	-	214+00	CTH C	62	133	104	
0010	214+00	-	236+00	CTH C	413	891	693	INCLUDES WIDER SHOULDER BY TRAIL
0010	236+00	-	243+50	CTH C	150	324	252	
0010	243+50	-	267+25	CTH C	444	956	744	
0010	267+25	-	273+00	CTH C	123	265	206	
0010	401+29	-	402+73	FRANKLIN RD	29	63	49	
TOTAL 0010					3,180	6,855	5,335	

ASPHALTIC FLUMES

465.0315  
ASPHALTIC  
FLUMES

CATEGORY	STATION	LOCATION	SY
0010	201+25	CTH C, LT	4
0010	268+25	CTH C, RT	4
0010	328+97	CTH F, LT	4
0010	329+10	CTH F, RT	4
0010	339+40	PARK LN, LT	4
TOTAL 0010			20

CONCRETE SURFACE DRAINS

602.3010  
CONCRETE  
SURFACE DRAINS

CATEGORY	STATION	LOCATION	CY
0010	211+54	CTH C, RT	2
0010	211+67	CTH C, LT	2
TOTAL 0010			4



3

3

CULVERTS

CATEGORY	STATION	LOCATION	520.1024	520.1030	521.0657	521.1228	521.1257	521.3728	521.3757	522.2338	522.2429	522.2629	522.2638	530.0124	530.0130	611.9850.S.01	611.9850.S.02	REMARKS
			APRON ENDWALLS FOR CULVERT PIPE 24-INCH EACH	APRON ENDWALLS FOR CULVERT PIPE 30-INCH EACH	APRON SLOPED CROSS DRAINS STEEL 57X38-INCH 6 TO 1 EACH	APRON ENDWALLS FOR PIPE ARCH STEEL 28X20-INCH EACH	APRON ENDWALLS FOR PIPE ARCH STEEL 57X38-INCH EACH	** PIPE ARCH CORRUGATED STEEL 28X20-INCH LF	*** PIPE ARCH CORRUGATED STEEL 57X38-INCH LF	CULVERT PIPE REINFORCED CONCRETE HORIZONTAL ELLIPTICAL CLASS HE-III 38X60-INCH LF	CULVERT PIPE REINFORCED CONCRETE HORIZONTAL ELLIPTICAL CLASS HE-IV 29X45-INCH LF	APRON ENDWALLS FOR CULVERT PIPE REINFORCED CONCRETE HORIZONTAL ELLIPTICAL 29X45-INCH EACH	APRON ENDWALLS FOR CULVERT PIPE REINFORCED CONCRETE HORIZONTAL ELLIPTICAL 38X60-INCH EACH	CULVERT PIPE CORRUGATED POLYETHYLENE 24-INCH LF	CULVERT PIPE CORRUGATED POLYETHYLENE 30-INCH LF	PIPE GRATES 29 X 45-INCH EACH	PIPE GRATES 38 X 60-INCH EACH	
0010	119+38	CTH C	-	-	-	2	-	52	-	-	-	-	-	-	-	-	-	
0010	119+44	CTH C	-	-	-	2	-	52	-	-	-	-	-	-	-	-	-	
0010	119+83	CTH C, RT	-	-	2	-	-	-	36	-	-	-	-	-	-	-	-	
0010	121+31	CTH C, RT	-	-	1	-	1	-	50	-	-	-	-	-	-	-	-	TYP ENDWALL BEHIND RAIL
0010	127+01	CTH C	-	2	-	-	-	-	-	-	-	-	-	-	86	-	-	
0010	150+67	CTH C	-	-	-	-	-	-	-	-	38	2	-	-	-	2	-	
0010	150+75	CTH C	-	-	-	-	-	-	-	-	38	2	-	-	-	2	-	
0010	158+10	CTH C	-	-	-	-	-	-	-	36	-	-	2	-	-	-	2	
0010	205+68	CTH C	2	-	-	-	-	-	-	-	-	-	-	74	-	-	-	
TOTAL 0010			2	2	3	4	1	104	86	36	76	4	2	74	86	4	2	

\*\* MINIMUM PIPE THICKNESS 0.064  
\*\*\* MINIMUM PIPE THICKNESS 0.109

STORM SEWER STRUCTURES

CATEGORY	STR NO.	STATION	OFFSET	LOCATION	522.1015	522.1024	522.2619	611.0535	611.0630	611.0633	611.0642	611.1006	611.1230	611.2005	611.3901	611.3902	SPV.0060.01	REMARKS
					APRON ENDWALLS FOR CULVERT PIPE REINFORCED CONCRETE 15-INCH EACH	APRON ENDWALLS FOR CULVERT PIPE REINFORCED CONCRETE 24-INCH EACH	APRON ENDWALLS FOR CULVERT PIPE REINFORCED CONCRETE HORIZONTAL ELLIPTICAL 19X30-INCH EACH	MANHOLE COVERS TYPE J- SPECIAL EACH	INLET COVERS TYPE HM-GJ EACH	INLET COVERS TYPE HM-GJ-S EACH	INLET COVERS TYPE MS EACH	CATCH BASINS 6-FT DIAMETER EACH	CATCH BASINS 2X3-FT EACH	MANHOLES 5-FT DIAMETER EACH	INLETS MEDIAN 1 GRATE EACH	INLETS MEDIAN 2 GRATE EACH	INLET COVERS TYPE H-D EACH	
0010	1	189+78	26.7' LT	CTH C	-	-	-	-	-	-	2	-	-	-	-	1	-	MEDIAN GRATE SLOPED
0010	2	189+85	15.5' LT	CTH C	-	-	-	-	1	-	-	1	-	-	-	-	-	
0010	4	191+26	15.5' LT	CTH C	-	-	-	-	1	-	-	1	-	-	-	-	-	
0010	5	191+27	34.5' RT	CTH C	-	-	1	-	-	-	-	-	-	-	-	-	-	
0010	8	192+72	15.5' LT	CTH C	-	-	-	-	1	-	-	-	1	-	-	-	-	
0010	9	195+00	--	CTH C	-	-	-	1	-	-	-	-	-	1	-	-	-	
0010	10	198+12	--	CTH C	-	-	-	1	-	-	-	-	-	1	-	-	-	
0010	11	200+31	--	CTH C	-	-	-	1	-	-	-	-	-	1	-	-	-	
0010	12	202+50	--	CTH C	-	-	-	1	-	-	-	-	-	1	-	-	-	
0010	13	205+00	--	CTH C	-	-	-	1	-	-	-	-	-	1	-	-	-	
0010	14	200+31	14.5' RT	CTH C	-	-	-	-	1	-	-	-	1	-	-	-	-	
0010	15	202+50	17.5' RT	CTH C	-	-	-	-	1	-	-	-	1	-	-	-	-	
0010	17	198+12	14.5' RT	CTH C	-	-	-	-	-	1	-	-	1	-	-	-	-	
0010	18	198+02	14.5' RT	CTH C	-	-	-	-	1	-	-	-	1	-	-	-	-	
0010	19	198+02	14.5' RT	CTH C	-	-	-	-	1	-	-	-	1	-	-	-	-	
0010	20	198+12	14.5' RT	CTH C	-	-	-	-	-	1	-	-	1	-	-	-	-	
0010	22	198+29	21.5' LT	CTH C	-	-	-	-	-	-	2	-	-	-	-	1	-	MEDIAN GRATE CROWNED
0010	23	205+25	44.2' RT	CTH C	-	1	-	-	-	-	-	-	-	-	-	-	-	
0010	25	202+50	21.4' RT	CTH C	1	-	-	-	-	-	-	-	-	-	-	-	-	
0010	26	195+00	23.0' LT	CTH C	-	-	-	-	-	-	1	-	-	-	1	-	-	
0010	27	195+00	14.5' RT	CTH C	-	-	-	-	1	-	-	-	1	-	-	-	-	
0010	28	271+25	17.4' LT	CTH C	-	-	-	-	-	-	-	-	1	-	-	-	1	
0010	30	200+31	20.5' LT	CTH C	-	-	-	-	-	-	1	-	-	-	1	-	-	
TOTAL 0010					1	1	1	5	8	2	6	2	9	5	2	2	1	

3

3

STORM SEWER PIPES

CATEGORY	STRUCTURE		STATION	TO	STATION	LOCATION	608.0312	608.0315	608.0324	608.2319	608.2419
	FROM	TO					STORM SEWER PIPE REINFORCED CONCRETE CLASS III 12-INCH LF	STORM SEWER PIPE REINFORCED CONCRETE CLASS III 15-INCH LF	STORM SEWER PIPE REINFORCED CONCRETE CLASS III 24-INCH LF	STORM SEWER PIPE REINFORCED CONCRETE HORIZONTAL ELLIPTICAL CLASS HE-III 19X30-INCH LF	STORM SEWER PIPE REINFORCED CONCRETE HORIZONTAL ELLIPTICAL CLASS HE-IV 19X30-INCH LF
0010	1	2	189+78	-	189+85	CTH C, LT	-	-	-	13	-
0010	2	4	189+85	-	191+26	CTH C, LT	-	-	-	137	-
0010	4	5	191+26	-	191+27	CTH C	-	-	-	-	50
0010	8	9	192+72	-	195+00	CTH C, LT	224	-	-	-	-
0010	9	10	195+00	-	198+12	CTH C	-	-	312	-	-
0010	26	27			195+00	CTH C, LT	8	-	-	-	-
0010	27	9			195+00	CTH C, LT	14	-	-	-	-
0010	19	20	198+02	-	198+12	CTH C, LT	10	-	-	-	-
0010	18	17	198+02	-	198+12	CTH C, RT	10	-	-	-	-
0010	17	10			198+12	CTH C, RT	14	-	-	-	-
0010	20	10			198+12	CTH C, LT	14	-	-	-	-
0010	22	20	198+12	-	198+29	CTH C, LT	18	-	-	-	-
0010	10	11	198+12	-	200+31	CTH C	-	-	219	-	-
0010	14	11			200+31	CTH C, RT	14	-	-	-	-
0010	30	11			200+31	CTH C, LT	20	-	-	-	-
0010	11	12	200+31	-	202+50	CTH C	-	-	219	-	-
0010	25	15			202+50	CTH C, RT	-	3	-	-	-
0010	15	12			202+50	CTH C, RT	-	17	-	-	-
0010	12	13	202+50	-	205+00	CTH C	-	-	250	-	-
0010	13	23	205+00	-	205+25	CTH C, RT	-	-	50	-	-
0010	28	EXIST	271+25	-	273+01	CTH C, LT	176	-	-	-	-
TOTAL 0010							522	20	1,050	150	50

TOTAL 0010 522 20 1,050 150 50

CURB & GUTTER

CATEGORY	STATION	TO	STATION	LOCATION	416.0610	601.0411	601.0415	601.0584	REMARKS
					DRILLED TIE BARS EACH	CONCRETE CURB & GUTTER 30-INCH TYPE D LF	CONCRETE CURB & GUTTER 6-INCH SLOPED 30-INCH TYPE J LF	CONCRETE CURB & GUTTER 4-INCH SLOPED 30-INCH TYPE TBT LF	
0010	189+75	-	201+25	CTH C, LT	-	-	1,150	-	
0010	193+14	-	193+60	CTH C, RT	-	-	98	-	
0010	193+85	-	202+78	CTH C, RT	-	-	947	-	
0010	211+14	-	211+63	CTH C, RT	-	-	-	49	
0010	211+28	-	211+73	CTH C, LT	-	-	-	45	
0010	268+25	-	273+00	CTH C, LT	-	475	-	-	
0010	269+88	-	273+00	CTH C, RT	4	440	-	-	INCLUDES FRANKLIN STREET
TOTAL 0010					4	915	2,195	94	

\*\* 2 TIE BARS AT EACH CONNECTION TO EXISTING C&G

RIPRAP

CATEGORY	STATION	LOCATION	606.0200	645.0120
			RIPRAP MEDIUM CY	GEOTEXTILE TYPE HR SY
0010	119+40	CTH C, LT	7	21
0010	119+50	CTH C, RT	10	29
0010	121+65	CTH C, RT	11	30
0010	158+10	CTH C, LT	6	18
0010	158+10	CTH C, RT	8	22
0010	205+30	CTH C, RT	6	18
0010	205+75	CTH C, RT	7	20
0010	211+54	CTH C, RT	5	16
0010	211+67	CTH C, LT	5	16
0010	UNDISTRIBUTED		15	30

TOTAL 0010 80 220

UNDERDRAIN

CATEGORY	STATION	TO	STATION	LOCATION	310.0110	612.0106	645.0111
					BASE AGGREGATE OPEN-GRADED TON	PIPE UNDERDRAIN 6-INCH LF	GEOTEXTILE TYPE DF SCHEDULE A SY
0010	198+02	-	198+22	CTH C, LT	6	20	14
0010	198+02	-	198+22	CTH C, RT	6	20	14
TOTAL 0010					12	40	28

TOTAL 0010 12 40 28

TRAIL CROSSINGS

CATEGORY	STATION	TO	STATION	LOCATION	602.0415	602.0515	SPV.0180.01
					CONCRETE SIDEWALK 6-INCH SF	CURB RAMP DETECTABLE WARNING FIELD NATURAL PATINA SF	PROTECTIVE POLYMER COATING AT SNOWMOBILE TRAIL CROSSING SY
0010	161+10	-	163+35	CTH C	440	216	195
0010	225+40	-	227+30	CTH C	324	158	167
0010	328+75	-	328+87	CTH F	96	40	50
TOTAL 0010					860	414	412

TOTAL 0010 860 414 412

3

SALVAGED RAIL

GUARDRAIL

SALVAGED RAIL						GUARDRAIL							REMARKS						
CATEGORY	STATION	TO	STATION	LOCATION	LF	CATEGORY	STATION	TO	STATION	LOCATION	LF	LF		LF	LF	EACH	EACH		
614.0920						614.2300	614.2330	614.2350	614.2500	614.2610	614.2630								
						MGS GUARDRAIL	MGS GUARDRAIL	MGS GUARDRAIL	MGS THRIE	MGS GUARDRAIL	MGS GUARDRAIL								
						3	3 K	SHORT RADIUS	BEAM	TERMINAL EAT	SHORT RADIUS								
						LF	LF	LF	LF	EACH	TERMINAL								
0010	121+18	-	121+89	CTH C, LT	71	0010	121+01	-	121+92	CTH C, LT	-	-	-	39.4	1	-			
0010	123+26	-	123+95	CTH C, LT	69	0010	121+38	-	122+09	CTH C, RT	53.1	-	16.5	39.4	-	1	3 CRT POSTS; VERIFY SHORT RADIUS LENGTHS		
0010	121+44	-	122+07	CTH C, RT	63	0010	123+23	-	124+52	CTH C, LT	37.5	-	-	39.4	1	-			
0010	123+44	-	124+12	CTH C, RT	68	0010	123+42	-	124+33	CTH C, RT	-	-	-	39.4	1	-			
0010	209+04	-	209+65	CTH C, LT	61	0010	208+08	-	209+51	CTH C, RT	50	-	-	39.4	1	-			
0010	211+28	-	212+28	CTH C, LT	100	0010	208+80	-	209+65	CTH C, LT	53.1	-	8.2	39.4	-	1	2 CRT POSTS; VERIFY SHORT RADIUS LENGTHS		
0010	208+56	-	209+51	CTH C, RT	95	0010	211+14	-	212+20	CTH C, RT	12.5	-	-	39.4	1	-			
0010	211+14	-	212+30	CTH C, RT	116	0010	211+28	-	212+72	CTH C, LT	50	-	-	39.4	1	-			
0010	236+50	-	243+20	CTH C, LT	670	0010	236+43	-	243+20	CTH C, LT	575	-	-	-	2	-			
0010	237+75	-	243+15	CTH C, RT	540	0010	237+86	-	243+21	CTH C, RT	275	150	-	-	2	-	FIELD VERIFY 1/2 POST SPACING		
TOTAL 0010						1,853	TOTAL 0010						1,106.3	150	24.7	315.2	10	2	

3

LANDSCAPING

CATEGORY	STATION	TO	STATION	LOCATION	625.0100	628.2004	628.2008	628.2027	629.0210	630.0120	630.0140	630.0500	REMARKS
					TOPSOIL	EROSION MAT	EROSION MAT	EROSION MAT	FERTILIZER	SEEDING	SEEDING	SEED WATER	
					SY	CLASS I TYPE B	URBAN CLASS I	CLASS II TYPE C	TYPE B	NO. 20	NO. 40	MGAL	
						SY	TYPE B	TYPE C	CWT	LB	LB		
0010	119+20	-	122+00	CTH C, LT	230	-	230	-	0.2	4	-	5	CULVERTS AND GUARD RAIL APPROACHES
0010	119+00	-	121+75	CTH C, RT	430	-	430	100	0.3	-	8	10	CULVERTS AND GUARD RAIL APPROACHES
0010	123+25	-	124+75	CTH C, RT	90	-	90	-	0.1	2	-	2	BRIDGE GUARD RAIL APPROACHES
0010	126+50	-	127+35	CTH C	200	-	200	10	0.2	4	-	5	CULVERT
0010	149+30	-	151+20	CTH C, LT	570	-	570	-	0.4	-	11	13	CULVERT AND DITCHING
0010	149+30	-	151+20	CTH C, RT	140	140	-	20	0.1	3	-	4	CULVERT AND DITCHING
0010	157+65	-	161+75	CTH C, LT	500	-	500	-	0.4	9	-	12	CULVERT AND GRADING
0010	157+65	-	158+65	CTH C, RT	60	-	60	-	0.1	1	-	2	CULVERT
0010	188+25	-	192+80	CTH C, LT	690	-	690	-	0.5	-	13	16	
0010	188+25	-	193+60	CTH C, RT	700	-	700	5	0.5	-	13	16	
0010	194+35	-	203+10	CTH C, LT	660	-	660	-	0.5	-	12	15	
0010	194+00	-	202+78	CTH C, RT	810	-	810	-	0.6	-	15	19	
0010	205+00	-	205+85	CTH C	160	160	-	-	0.1	3	-	4	CULVERT AND STROM OUTFALL
0010	207+75	-	209+55	CTH C, RT	200	-	200	-	0.2	4	-	5	BRIDGE GUARD RAIL APPROACHES
0010	211+15	-	212+60	CTH C, RT	140	-	140	-	0.1	3	-	3	BRIDGE GUARD RAIL APPROACHES
0010	235+50	-	237+00	CTH C, LT	360	-	360	-	0.3	7	-	8	GUARD RAIL APPROACHES
0010	242+60	-	243+70	CTH C, RT	70	70	-	-	0.1	2	-	2	GUARD RAIL APPROACHES
0010	268+25	-	273+00	CTH C	150	-	150	-	0.1	3	3	4	
0010	UNDISTRIBUTED				1,240	80	1,160	35	0.2	15	15	25	
TOTAL 0010					7,400	450	6,950	170	5.0	60	90	170	

SILT FENCE

CATEGORY	STATION TO	STATION	LOCATION	628.1504	628.1520
				SILT FENCE LF	SILT FENCE MAINTENANCE LF
0010	120+40	- 122+00	CTH C, LT	180	360
0010	121+50	- 122+20	CTH C, RT	100	200
0010	123+40	- 124+50	CTH C, RT	140	280
0010	126+70	- 127+35	CTH C, LT	80	160
0010	126+65	- 127+30	CTH C, RT	100	200
0010	157+70	- 161+75	CTH C, LT	440	880
0010	157+70	- 158+40	CTH C, RT	150	300
0010	194+35	- 197+00	CTH C, LT	220	440
0010	205+00	- 206+90	CTH C, RT	150	300
0010	207+50	- 209+50	CTH C, RT	210	420
0010	211+20	- 212+55	CTH C, RT	180	360
0010	235+35	- 237+00	CTH C, LT	150	300
0010	242+45	- 243+60	CTH C, LT	120	240
0010	268+10	- 268+90	CTH C, LT	80	160
0010	UNDISTRIBUTED			500	1,000
TOTAL 0010				2,800	5,600

MOBILIZATIONS EROSION CONTROL

CATEGORY	STATION TO	STATION	LOCATION	628.1905	628.1910
				MOBILIZATIONS EROSION CONTROL EACH	MOBILIZATIONS EMERGENCY EROSION CONTROL EACH
0010	109+25	- 273+00	CTH C	5	4
TOTAL 0010				5	4

PIPE CHECKS

CATEGORY	STATION TO	STATION	LOCATION	628.7555	628.7570	REMARKS
				CULVERT PIPE CHECKS EACH	ROCK BAGS EACH	
0010	119+25	- 119+70	CTH C, RT	14	24	MULTIPLE CULVERTS
0010	121+10	- 121+10	CTH C, RT	8	-	
0010	126+75	- 127+25	CTH C, LT	5	24	MULTIPLE CULVERTS
0010	149+50	- 150+75	CTH C	12	32	
0010	157+75	- 158+30	CTH C, LT	8	24	
0010	202+50	- 202+50	CTH C, RT	8	-	
0010	205+50	- 205+75	CTH C, LT	5	12	
TOTAL 0010				60	116	

INLET PROTECTION

CATEGORY	STRUCT NO	STATION	OFFSET	LOCATION	628.7005	628.7010	628.7015
					INLET PROTECTION TYPE A EACH	INLET PROTECTION TYPE B EACH	INLET PROTECTION TYPE C EACH
0010	1	189+78	26.7' LT	CTH C	1	1	-
0010	2	189+85	15.3' LT	CTH C	1	-	1
0010	4	191+26	15.3' LT	CTH C	1	-	1
0010	8	192+78	15.4' LT	CTH C	1	-	1
0010	14	200+31	14.4' RT	CTH C	1	-	1
0010	15	202+50	17.4' RT	CTH C	1	-	1
0010	17	198+12	14.4' RT	CTH C	1	-	1
0010	18	198+02	14.4' RT	CTH C	1	-	1
0010	19	198+02	14.4' LT	CTH C	1	-	1
0010	20	198+12	14.4' LT	CTH C	1	-	1
0010	22	198+29	20.5' LT	CTH C	1	1	-
0010	26	195+00	21.1' LT	CTH C	1	1	-
0010	27	195+00	14.4' LT	CTH C	1	-	1
0010	28	271+25	17.4' LT	CTH C	1	-	1
0010	30	200+31	20' LT	CTH C	1	1	-
0010	EXIST	273+00	17.4' LT	CTH C	-	-	1
0010	EXIST	273+00	17.4' RT	CTH C	-	-	1
TOTAL 0010					15	4	13

MARKING

CATEGORY	STATION TO	STATION	LOCATION	646.1020 MARKING LINE EPOXY 4-INCH		646.3020	648.0100	REMARKS
				YELLOW LF	WHITE LF	MARKING LINE EPOXY 8-INCH WHITE LF	LOCATING NO-PASSING ZONES WHITE MI	
0010	109+25	- 273+00	CTH C	-	-	-	3.05	PROJECT
0010	109+25	- 116+00	CTH C	840	1,200	-	-	
0010	116+00	- 145+00	CTH C	725	5,700	-	-	
0010	145+00	- 154+00	CTH C	1,125	1,800	-	-	
0010	154+00	- 173+00	CTH C	3,800	3,800	-	-	
0010	173+00	- 181+50	CTH C	1,060	1,700	-	-	
0010	181+50	- 190+00	CTH C	1,060	1,700	-	-	
0010	190+00	- 193+15	CTH C	630	315	100	-	NO WHITE ALONG CURBED AREAS
0010	193+15	- 203+00	CTH C	1,970	-	-	-	NO WHITE ALONG CURBED AREAS
0010	203+00	- 229+50	CTH C	660	5,150	-	-	
0010	229+50	- 238+00	CTH C	1,060	1,700	-	-	
0010	238+00	- 248+00	CTH C	2,000	2,000	-	-	
0010	248+00	- 256+50	CTH C	1,060	1,700	-	-	
0010	256+50	- 261+00	CTH C	110	900	-	-	
0010	261+00	- 268+00	CTH C	875	1,400	-	-	
0010	268+00	- 273+00	CTH C	1,000	160	-	-	NO WHITE ALONG CURBED AREAS
0010	327+70	- 329+50	CTH F	360	230	-	-	
0010	401+25	- 402+60	FRANKLIN RD	270	-	-	-	DOUBLE YELLOW
SUBTOTAL				18,605	29,455			
TOTAL 0010				48,060		100	3.05	

TRAFFIC CONTROL																
* * *																
643.0300 643.0420 643.0705 643.0900 643.1050																
TRAFFIC CONTROL TRAFFIC CONTROL TRAFFIC CONTROL TRAFFIC CONTROL																
BARRICADES WARNING SIGNS CONTROL SIGNS																
CATEGORY	STATION	TO	STATION	LOCATION	APPROXIMATE SERVICE PERIOD DAYS	NO. IN SERVICE	TRAFFIC CONTROL DRUMS DAY	NO. IN SERVICE	TYPE III DAY	NO. IN SERVICE	LIGHTS TYPE A DAY	NO. IN SERVICE	SIGNS DAY	NO. IN SERVICE	PCMS DAY	REMARKS
0010	109+25	-	273+00	CTH C	100	0	0	12	1,200	24	2,400	8	800	2	14	ROAD CLOSURE MAINLINE
0010	109+25	-	273+00	SIDE ROADS	100	0	0	32	3,200	64	6,400	24	2,400	0	0	SIDE ROAD CLOSURES / ROAD WORK AHEAD
0010	119+00	-	206+00	CTH C	15	0	0	10	150	12	180	6	90	0	0	CULVERT REPLACEMENTS WITHIN ROAD CLOSURE
0010	157+25	-	165+50	CTH C	20	0	0	4	80	8	160	4	80	0	0	ADDITIONAL ITEMS FOR RECONSTRUCTION AREA
0010	189+75	-	202+78	CTH C	40	0	0	4	160	8	320	8	320	0	0	ADDITIONAL ITEMS FOR RECONSTRUCTION AREA
0010	121+00	-	246+00	CTH C	10	30	300	0	0	0	0	4	40	0	0	GUARDRAIL REPLACEMENTS
0010	268+20	-	273+00	CTH C	10	30	300	0	0	0	0	4	40	0	0	CURB & GUTTER CONSTRUCTION
0010	AHNAPEE TRAIL CROSSINGS			CTH C, CTH F	100	0	0	4	400	8	800	18	1,800	0	0	WORK ZONE SIGNS FOR TRAIL APPROACHES
0010	UNDISTRBUTED				-	-	-	-	310	-	540	-	230	-	0	
TOTAL 0010							600		5,500		10,800		5,800		14	

\*ADDITIONAL QUANTITIES SHOWN ELSEWHERE

TEMPORARY PEDESTRIAN BARRICADE

644.1810 TEMPORARY PEDESTRIAN BARRICADE						
CATEGORY	STATION	TO	STATION	LOCATION	LF	REMARKS
0010	160+75	-	163+50	CTH C TRAIL CROSSING	700	2 STAGES
0010	225+00	-	227+50	CTH C TRAIL CROSSING	650	2 STAGES
0010	328+65	-	328+85	CTH F TRAIL CROSSING	200	2 STAGES
TOTAL 0010					1,550	

STAKING

650.4000 650.4500 650.5000 650.5500 650.6000 650.8000 650.9500.01 650.9911.01 650.9920																
CONSTRUCTION CONSTRUCTION CONSTRUCTION CONSTRUCTION CONSTRUCTION CONSTRUCTION CONSTRUCTION CONSTRUCTION CONSTRUCTION CONSTRUCTION																
STAKING STAKING STAKING STAKING STAKING STAKING STAKING STAKING STAKING STAKING																
SEWER SUBGRADE CONSTRUCTION CURB & GUTTER STAKING PIPE RESURFACING SIDEWALK CONTROL STAKING SLOPE																
CATEGORY	STATION	TO	STATION	LOCATION	EACH	LF	LF	LF	EACH	LF	EACH	EACH	EACH	LF	REMARKS	
0010	109+25	-	273+00	CTH C	-	-	-	-	-	-	1	1	-	-		
0010	109+25	-	121+98	CTH C	-	-	-	-	4	1,273	-	-	150		SLOPE STAKING FOR GUARDRAIL EAT GRADING	
0010	123+35	-	157+25	CTH C	-	-	-	-	3	3,390	-	-	115		SLOPE STAKING FOR GUARDRAIL EAT GRADING	
0010	157+25	-	163+00	CTH C	-	575	575	-	1	-	-	-	575			
0010	163+00	-	189+75	CTH C	-	-	-	-	-	2,675	-	-	-			
0010	189+75	-	202+78	CTH C	20	1,303	1,303	2,195	-	-	-	-	-	1,303		
0010	202+78	-	209+67	CTH C	2	-	-	-	1	689	-	-	235		SLOPE STAKING FOR GUARDRAIL EAT GRADING	
0010	211+11	-	268+25	CTH C	-	-	-	94	-	5,714	-	-	500		SLOPE STAKING FOR GUARDRAIL EAT GRADING	
0010	268+25	-	273+00	CTH C	1	-	-	911	-	475	-	-	-			
0010	327+71	-	330+00	CTH F	-	229	229	-	-	-	-	-	229			
0010	401+29	-	402+89	FRANKLIN ST	-	-	-	-	-	160	-	-	-			
TOTAL 0010					23	2,107	2,107	3,200	9	14,376	1	1	3,107			

**TRAFFIC CONTROL DETOUR SIGN SUMMARY - PROJECT 4390-07-71**

SIGN NO.	LOCATION	SIGN CODE	SIZE W X H	NUMBER IN SERVICE	APPROX. SERVICE PERIOD 100 DAYS	* 643.0900	* 643.0420	* 643.0705	NO OF CYCLES	643.0920	REMARKS
						SIGNS	BARRICADES TYPE III	WARNING LIGHTS TYPE A		COVERING SIGNS TYPE II	
A	CTH C, 1500 FT NORTH OF CTH B	M 1-5A	24"x24"	1	100	100					C
	"	W 20-2A	48"x48"	1	100	100					
B	CTH C, 750 FEET NORTH OF CTH B								1	1	COVER "^ KEWAUNEE"
C	CTH C, 500 FT NORTH OF CTH B	MO 4-8	24"x12"	1	100	100					
	"	M 1-5A	24"x24"	1	100	100					C
	"	MO 5-1R	21"x21"	1	100	100					
D	CTH C, 50 FT NORTH OF CTH B	MO 4-8	24"x12"	1	100	100					
	"	M 1-5A	24"x24"	1	100	100					C
	"	MO 6-1R	21"x21"	1	100	100					
E	CTH C, SOUTH SIDE OF CTH B INTERSECTION	R 11-3	60"x30"	1	100	100	100	200			1.7 MILES AHEAD
F	CTH B, 250 FT SOUTH OF CTH C, SOUTHBOUND	MO 4-8	24"x12"	1	100	100					
	"	M 1-5A	24"x24"	1	100	100					C
G	CTH B, 400 FT NORTH OF CTH F, SOUTHBOUND								1	1	COVER "<- KEWAUNEE"
H	CTH B, 100 FT SOUTH OF CTH F, SOUTHBOUND	MO 4-8	24"x12"	1	100	100					
	"	M 1-5A	24"x24"	1	100	100					C
I	CTH C, 500 FT NORTH OF CTH B	MO 4-8	24"x12"	1	100	100					
	"	M 1-5A	24"x24"	1	100	100					C
	"	MO 5-1L	21"x21"	1	100	100					
J	CTH C, 50 FT NORTH OF CTH B	MO 4-8	24"x12"	1	100	100					
	"	M 1-5A	24"x24"	1	100	100					C
	"	MO 6-1L	21"x21"	1	100	100					
K	STH 29, 100 FT EAST OF CTH B, EASTBOUND	MO 4-8	24"x12"	1	100	100					
	"	M 1-5A	24"x24"	1	100	100					C
L	STH 29, 750 FT WEST OF CTH C	MO 4-8A	24"x18"	1	100	100					
	"	M 1-5A	24"x24"	1	100	100					C
M	CTH C, 1000 FT SOUTH OF STH 29	M 1-5A	24"x24"	1	100	100					C
	"	W 20-2A	48"x48"	1	100	100					
N	CTH C, 500 FT SOUTH OF STH 29	MO 4-8	24"x12"	1	100	100					
	"	M 1-5A	24"x24"	1	100	100					C
	"	MO 5-1L	21"x21"	1	100	100					
O	CTH C, AT STOP TO STH 29; MODIFY EXISTING ROUTE MARKER	MO 4-8	24"x12"	1	100	100					
	"	M 1-5A	24"x24"								USE EXISTING COUNTY C MARKER
	COVER EXISTING RIGHT ARROW WITH LEFT ARROW	MO 6-1L	21"x21"	1	100	100			1	1	COVER RIGHT ARROW
P	STH 29, 750 FT WEST OF CTH C FRANKLIN STREET								1	1	COVER "KEWAUNEE FISHERIES FACILITY"
Q	STH 29, AT CTH C FRANKLIN STREET								1	1	COVER ENTIRE ASSEMBLY
R	STH 29, 1000 FT EAST OF CTH C ELLIS STREET	M 1-5A	24"x24"	1	100	100					C
	"	W 20-2A	48"x48"	1	100	100					
S	STH 29, 500 FT EAST OF CTH C ELLIS STREET	MO 4-8	24"x12"	1	100	100					
	"	M 1-5A	24"x24"	1	100	100					C
	"	MO 5-2L	21"x21"	1	100	100					
T	STH 29, 400 FT EAST OF CTH C ELLIS STREET								1	1	COVER "KEWAUNEE FISHERIES FACILITY"
U	STH 29, 350 FT EAST OF CTH C ELLIS STREET								1	1	COVER "BRUEMMER PARK / CASCO"
V	STH 29, AT CTH C ELLIS STREET	MO 4-8	24"x12"	1	100	100					
	"	M 1-5A	24"x24"								USE EXISTING COUNTY C MARKER
	COVER EXISTING RIGHT ARROW WITH TILT LEFT ARROW	MO 6-2L	21"x21"	1	100	100			1	1	COVER EXISTING MULTI ARROW
PAGE SUBTOTALS				37		3,700	100	200		8	

\*ADDITIONAL QUANTITIES SHOWN ELSEWHERE

**TRAFFIC CONTROL DETOUR SIGN SUMMARY - PROJECT 4390-07-71 CONTINUED**

SIGN NO.	LOCATION	SIGN CODE	SIZE W X H	NUMBER IN SERVICE	APPROX. SERVICE PERIOD 14 DAYS	* 643.0900	* 643.0420	* 643.0705	NO OF CYCLES	643.0920	REMARKS
						SIGNS	BARRICADES TYPE III	WARNING LIGHTS TYPE A		COVERING SIGNS TYPE II	
W	CTH C ELLIS STREET AT STH 29	R 11-4	60"X30"	1	100	100	100	200			
X	CTH C FRANKLIN STREET AT STH 29	R 11-4	60"X30"	1	100	100	100	200			
Y	STH 29, 150 FT WEST OF CTH C FRANKLIN STREET	MO 4-8	24"X12"	1	100	100					
	"	M 1-5A	24"X24"	1	100	100					C
Z	STH 29, 250 FT WEST OF CTH C SOUTH	MO 4-8	24"X12"	1	100	100					
	"	M 1-5A	24"X24"	1	100	100					C
AA	STH 29, 750 FT EAST OF CTH B	MO 4-8	24"X12"	1	100	100					
	"	M 1-5A	24"X24"	1	100	100					C
	"	MO 5-1R	21"X21"	1	100	100					
BB	STH 29, 50 FT EAST OF CTH B	MO 4-8	24"X12"	1	100	100					
	"	M 1-5A	24"X24"	1	100	100					C
	"	MO 6-1R	21"X21"	1	100	100					
CC	CTH B, 150 FT NORTH OF STH 29	MO 4-8	24"X12"	1	100	100					
	"	M 1-5A	24"X24"	1	100	100					C
DD	CTH B, 150 FT NORTH OF CTH F	MO 4-8	24"X12"	1	100	100					
	"	M 1-5A	24"X24"	1	100	100					C
EE	STH 29, 750 FT WEST OF CTH C	MO 4-8A	24"X18"	1	100	100					
	"	M 1-5A	24"X24"	1	100	100					C
PAGE SUBTOTALS				18		1,800	200	400		0	
<b>DETOUR 4390-07-71 TOTALS</b>				<b>55</b>		<b>5,500</b>	<b>300</b>	<b>600</b>		<b>8</b>	

\*ADDITIONAL QUANTITIES SHOWN ELSEWHERE

SAWING

CATEGORY	STATION TO	STATION	LOCATION	690.0150	690.0250	REMARKS
				SAWING ASPHALT LF	SAWING CONCRETE LF	
0010	119+18 -	119+70	CTH C	56	-	CULVERT REPLACEMENT
0010	126+55 -	127+45	CTH C	80	-	CULVERT REPLACEMENT
0010	150+40 -	151+10	CTH C	52	-	CULVERT REPLACEMENT
0010	157+70 -	158+50	CTH C	52	-	CULVERT REPLACEMENT
0010	205+21 -	206+15	CTH C	60	-	CULVERT REPLACEMENT
0010	121+10 -	121+50	CTH C, RT	11	-	DRIVEWAY
0010	142+00 -	146+00	CTH C, RT	40	-	DRIVEWAYS
0010		327+71	CTH F	28	-	CONSTRUCTION LIMIT
0010	327+70 -	328+55	CTH F	90	-	DRIVEWAYS
0010		197+82	CTH C, RT	-	4	SIDEWALK
0010	199+20 -	200+90	CTH C, LT	26	-	DRIVEWAYS
0010	268+90 -	271+35	CTH C, LT	245	-	DRIVEWAY/PARKING
0010		273+00	CTH C	-	6	CURB & GUTTER
0010		401+29	FRANKLIN RD, RT	-	3	CURB & GUTTER
TOTAL 0010				740	13	



# TRANSPORTATION PROJECT PLAT NO: 4390-07-71-4.01

THAT PART OF THE NORTHEAST QUARTER OF THE SOUTHEAST QUARTER (NE1/4 OF THE SE1/4) OF SECTION 10, TOWNSHIP 23 NORTH, RANGE 24 EAST, IN THE TOWN OF WEST KEWAUNEE, KEWAUNEE COUNTY, WISCONSIN.

### RELOCATION ORDER CTH "C" - KEWAUNEE COUNTY

TO PROPERLY ESTABLISH, LAY OUT, WIDEN, ENLARGE, EXTEND, CONSTRUCT, RECONSTRUCT, IMPROVE, OR MAINTAIN A PORTION OF THE HIGHWAY DESIGNATED ABOVE, THE KEWAUNEE COUNTY HIGHWAY DEPARTMENT DEEMS IT NECESSARY TO RELOCATE OR CHANGE SAID HIGHWAY AND ACQUIRE CERTAIN LANDS AND INTERESTS OR RIGHTS IN LANDS FOR THE ABOVE PROJECT.

TO EFFECT THIS CHANGE, PURSUANT TO AUTHORITY GRANTED UNDER SECTION 83.07 AND 83.08, WISCONSIN STATUTES, THE KEWAUNEE COUNTY HIGHWAY DEPARTMENT HEREBY ORDERS THAT:

- THAT PORTION OF SAID HIGHWAY AS SHOWN ON THIS PLAT IS LAID OUT AND ESTABLISHED TO THE LINES AND WIDTHS AS SO SHOWN FOR THE ABOVE PROJECT.
- THE LANDS OR INTERESTS OR RIGHTS IN LANDS AS SHOWN ON THIS PLAT ARE REQUIRED BY THE DEPARTMENT FOR THE ABOVE PROJECT AND SHALL BE ACQUIRED IN THE NAME OF KEWAUNEE COUNTY, PURSUANT TO THE PROVISIONS OF SECTION 83.07 AND 83.08, WISCONSIN STATUTES.

PARCEL NUMBER	OWNER(S)	INTEREST(S) REQUIRED	RW ACRES			
			NEW	EXISTING	TOTAL	TLE
1	ILONA M. RICE	TLE	-----	-----	-----	0.017

OWNER'S NAMES ARE SHOWN FOR REFERENCE PURPOSES ONLY AND ARE SUBJECT TO CHANGE PRIOR TO THE TRANSFER OF LAND INTERESTS TO THE DEPARTMENT. PURPOSE OF ALL THE TLES IS FOR GRADING, UNLESS NOTED.

POINT	STATION	OFFSET
100	129+46.06	41.25'LT
101	128+59.55	59.79'RT
102	125+47.27	60.00'RT
103	124+46.93	65.00'RT
104	121+46.94	65.00'RT
105	120+46.94	55.00'RT
106	120+46.93	60.00'LT
107	123+46.93	60.00'LT
108	124+46.93	41.25'LT
109	125+31.47	41.25'LT
110	127+47.52	41.25'LT

480137

RECEIVED FOR RECORD  
REGISTERED  
DEPARTMENT OF DEEDS, KEWAUNEE COUNTY, WISCONSIN

RECEIPT # 8202, STATION 1  
\$26.00 TRANS PROJECT PLAT

RESERVED FOR REGISTER OF DEEDS  
PROJECT NUMBER 4390-07-71- 4.01  
SHEET 1 OF 2

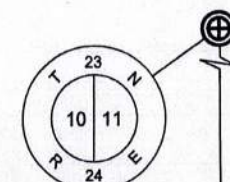
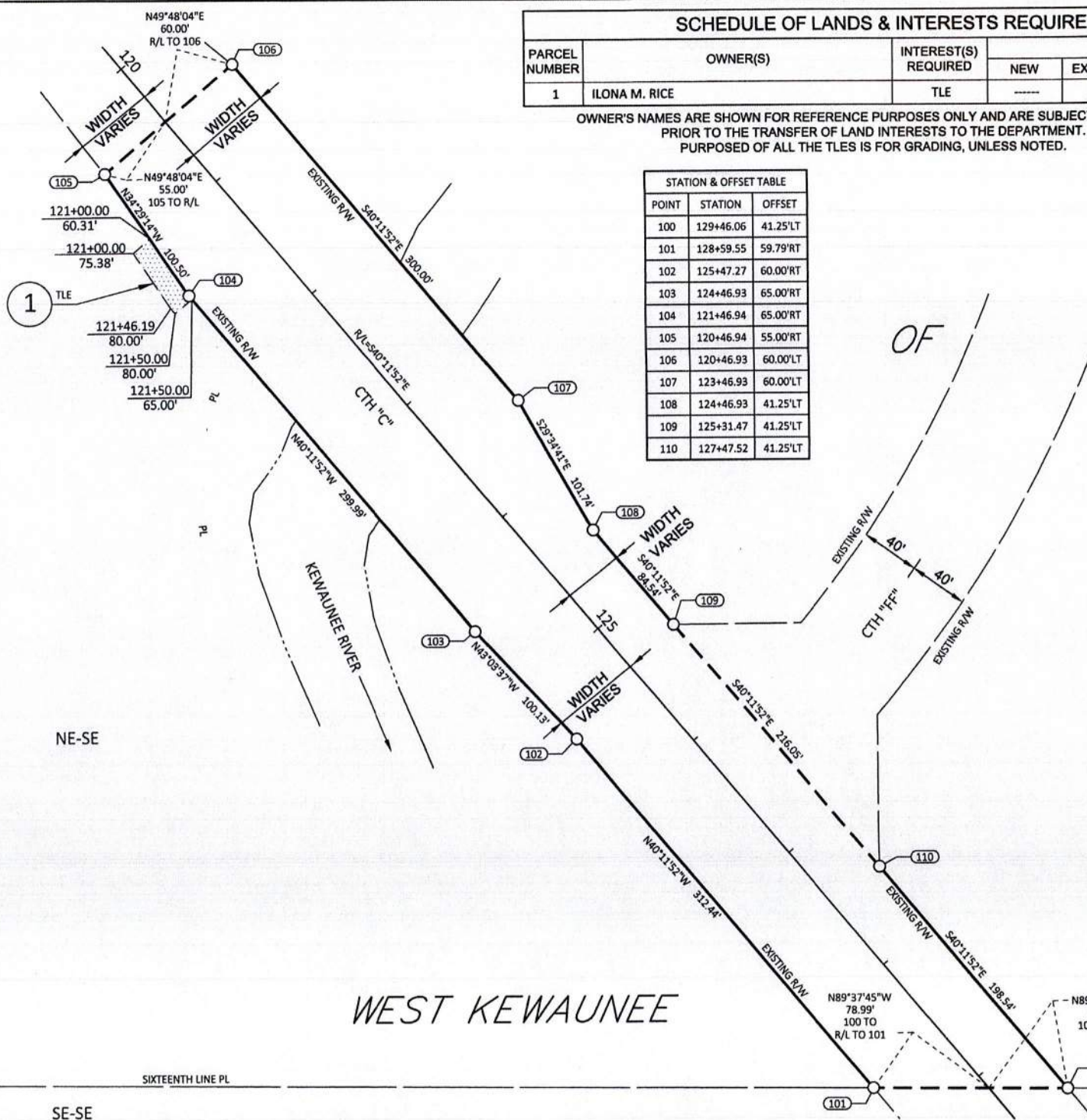

FOUND ALUMINUM MONUMENT  
Y=511001.898  
X=211711.077

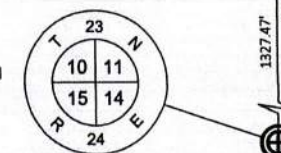

FOUND ALUMINUM MONUMENT  
Y=439595.972  
X=258782.768

NOTES:  
POSITIONS SHOWN ON THIS PLAT ARE WISCONSIN COORDINATE REFERENCE SYSTEM COORDINATES (WISCRS), KEWAUNEE COUNTY, NAD83(2011), IN U.S. SURVEY FEET. VALUES ARE GRID COORDINATES, GRID BEARINGS, AND GRID DISTANCES. GRID DISTANCES MAY BE USED AS GROUND DISTANCES.

ALL NEW RIGHT-OF-WAY MONUMENTS WILL BE TYPE 2 (TYPICALLY 3/4" X 24" IRON REBARS), UNLESS OTHERWISE NOTED, AND WILL BE PLACED PRIOR TO THE COMPLETION OF THE PROJECT.

FOR THE LATEST ACCESS/DRIVEWAY INFORMATION, CONTACT THE KEWAUNEE COUNTY HIGHWAY DEPARTMENT.

ALL EXISTING IRON PINS ARE 5/8" CAPPED REBARS UNLESS OTHERWISE NOTED.

EXISTING HIGHWAY RIGHT-OF-WAY SHOWN HEREIN IS BASED ON THE FOLLOWING POINTS OF REFERENCE:  
CTH C: RIGHT OF WAY PROJECT 4390-3-71  
CTH FF: RIGHT OF WAY PROJECT E 0-0(27)

FOR ADDITIONAL INFORMATION REFER TO THE TITLE SHEET, RECORDED AS SHEET 2 OF 2.

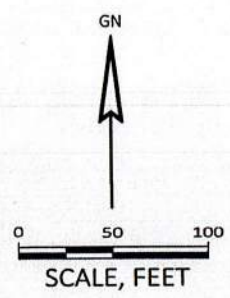

**JACOB S. JENSEN**  
S-2961  
ASHWAUBENON, WI

I, JACOB S. JENSEN, PROFESSIONAL LAND SURVEYOR, HEREBY CERTIFY THAT IN FULL COMPLIANCE WITH THE PROVISIONS OF SECTION 84.095 OF THE WISCONSIN STATUTES AND UNDER THE DIRECTION OF KEWAUNEE COUNTY, I HAVE SURVEYED AND MAPPED THIS TRANSPORTATION PROJECT PLAT 4390-07-71-4.01 AND THAT SUCH PLAT CORRECTLY REPRESENTS ALL EXTERIOR BOUNDARIES OF THE SURVEYED LAND.

JULY 17, 2023  
DATE

JACOB S. JENSEN  
REGISTRATION NUMBER: S-2961

THIS PLAT AND RELOCATION ORDER ARE APPROVED FOR KEWAUNEE COUNTY.

*Todd Every*  
TODD EVERY  
KEWAUNEE COUNTY HIGHWAY COMMISSIONER

7-20-23  
DATE



# STATE OF WISCONSIN DEPARTMENT OF TRANSPORTATION TRANSPORTATION PROJECT PLAT TITLE SHEET 4390-07-71

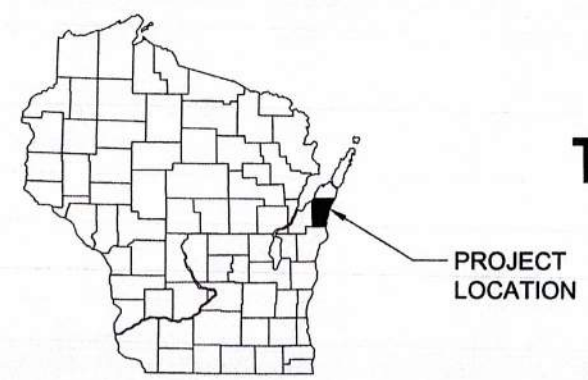

## CTH "C" KEWAUNEE COUNTY

4

4

**CONVENTIONAL SYMBOLS**

SECTION LINE	---	SECTION CORNER SYMBOL		R/W MONUMENT (TO BE SET)	●
QUARTER LINE	---	SECTION CORNER MONUMENT		NON-MONUMENTED R/W POINT	○
SIXTEENTH LINE	---	GEODETIC SURVEY MONUMENT		FOUND IRON PIN (1-INCH UNLESS NOTED)	IP
NEW REFERENCE LINE	---	SIXTEENTH CORNER MONUMENT		OFF-PREMISE SIGN	
NEW R/W LINE	---	SIGN		COMPENSABLE	
EXISTING R/W OR HE LINE	---	OFF-PREMISE SIGN		NON-COMPENSABLE	
PROPERTY LINE	---	ELECTRIC POLE		TELEPHONE POLE	
LOT, TIE & OTHER MINOR LINES	---	PEDESTAL (LABEL TYPE) (TV, TEL, ELEC, ETC.)		ACCESS RESTRICTED BY ACQUISITION	
SLOPE INTERCEPT	---	ACCESS RESTRICTED (BY STATUTORY AUTHORITY)		NO ACCESS (BY STATUTORY AUTHORITY)	
CORPORATE LIMITS	---	ACCESS RESTRICTED (BY PREVIOUS PROJECT OR CONTROL)		NO ACCESS (NEW HIGHWAY)	
UNDERGROUND FACILITY (COMMUNICATIONS, ELECTRIC, ETC.)	---	NO ACCESS (NEW HIGHWAY)		PARCEL NUMBER 25	UTILITY NUMBER 40
NEW R/W (FEE OR HE) (HATCHING VARIES BY OWNER)	---	PARCEL NUMBER 25		UTILITY NUMBER 40	
TEMPORARY LIMITED EASEMENT AREA	---	PARALLEL OFFSETS			
EASEMENT AREA (PERMANENT LIMITED OR RESTRICTED DEVELOPMENT)	---				
TRANSMISSION STRUCTURES	---				
BUILDING TO BE REMOVED					
BRIDGE					

**CONVENTIONAL ABBREVIATIONS**

ACCESS RIGHTS	AR	POINT OF INTERSECTION	PI
ACRES	AC	PROPERTY LINE	PL
AHEAD	AH	RECORDED AS (100')	R/I
ALUMINUM	ALUM	REEL / IMAGE	R/L
AND OTHERS	ET AL	REFERENCE LINE	REM
BACK	BK	REMAINING	RDE
BLOCK	BLK	RESTRICTIVE DEVELOPMENT	RT
CENTERLINE	C/L	EASEMENT	R/W
CERTIFIED SURVEY MAP	CSM	RIGHT	SEC
CONCRETE	CONC	RIGHT OF WAY	SEPV
COUNTY	CO	SECTION	SF
COUNTY TRUNK HIGHWAY	CTH	SEPTIC VENT	STH
DISTANCE	DIST	SQUARE FEET	STA
CORNER	COR	STATE TRUNK HIGHWAY	TP
DOCUMENT NUMBER	DOC	STATION	TLE
EASEMENT	EASE	TELEPHONE PEDESTAL	TPP
EXISTING	EX	TEMPORARY LIMITED EASEMENT	USH
GAS VALVE	GV		V
GRID NORTH	GN	TRANSPORTATION PROJECT PLAT	
HIGHWAY EASEMENT IDENTIFICATION	HE	UNITED STATES HIGHWAY	
LAND CONTRACT	LC	VOLUME	
LEFT	LT		
MONUMENT	MON		
NATIONAL GEODETIC SURVEY NUMBER	NGS		
OUTLOT	NO		
PAGE	OL		
POINT OF TANGENCY	P		
PERMANENT LIMITED EASEMENT	PT		
POINT OF BEGINNING	PLE		
POINT OF CURVATURE	POB		
POINT OF COMPOUND CURVE	PC		
	PCC		

**CURVE DATA**

LONG CHORD	LCH
LONG CHORD BEARING	LCB
RADIUS	R
DEGREE OF CURVE	D
CENTRAL ANGLE	Δ/DELTA
LENGTH OF CURVE	L
TANGENT	T
DIRECTION AHEAD	DA
DIRECTION BACK	DB

**CONVENTIONAL UTILITY SYMBOLS**

---	WATER
---	GAS
---	TELEPHONE
---	OVERHEAD
---	TRANSMISSION LINES
---	ELECTRIC
---	CABLE TELEVISION
---	FIBER OPTIC
---	SANITARY SEWER
---	STORM SEWER

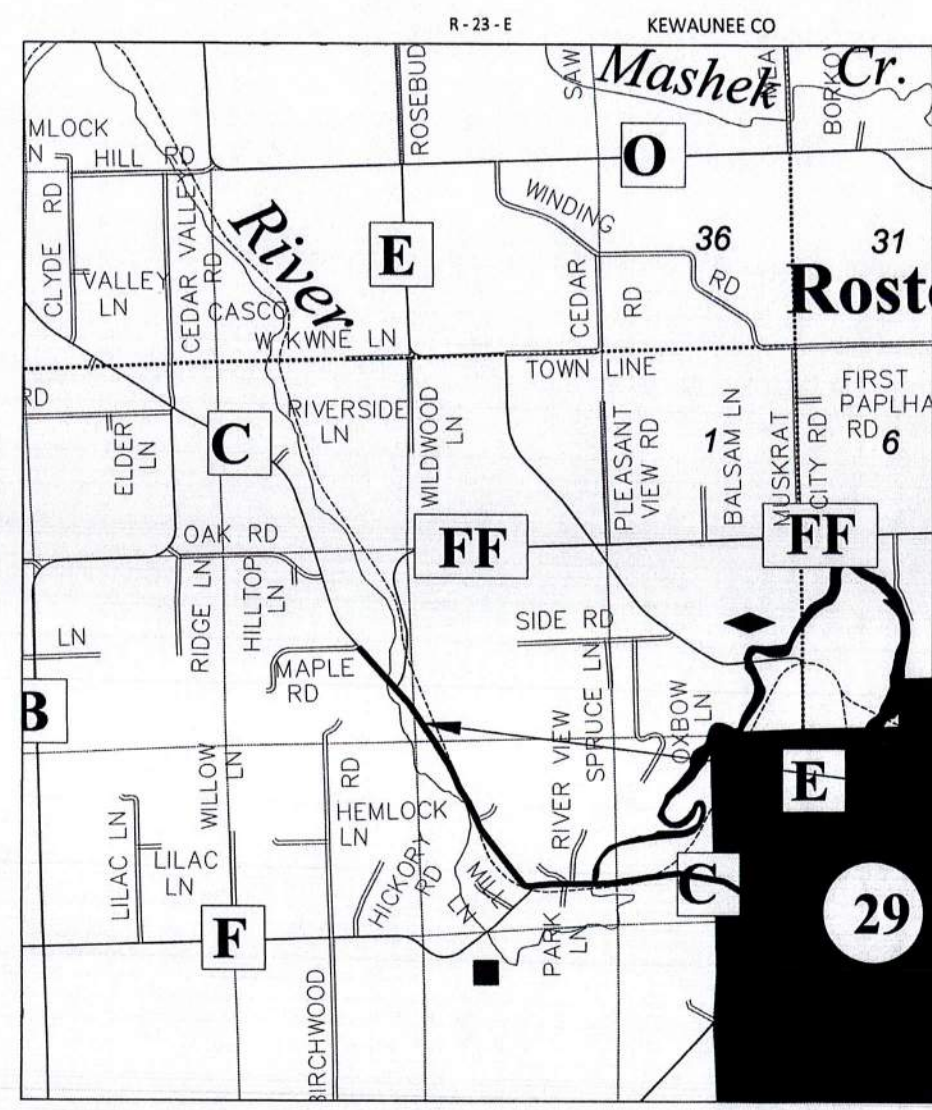

T - 24 - N  
T - 23 - N

PROJECT LOCATION

THE NOTES, CONVENTIONAL SIGNS, AND ABBREVIATIONS ARE ASSOCIATED WITH EACH TRANSPORTATION PROJECT PLAT FOR PROJECT 4390-07-71.

POSITIONS SHOWN ON THIS PLAT ARE WISCONSIN COORDINATE REFERENCE SYSTEM COORDINATES (WISCRS), KEWAUNEE COUNTY, NAD83(2011), IN U.S. SURVEY FEET. VALUES ARE GRID COORDINATES, GRID BEARINGS, AND GRID DISTANCES. GRID DISTANCES MAY BE USED AS GROUND DISTANCES.

ALL NEW RIGHT-OF-WAY MONUMENTS WILL BE TYPE 2 (TYPICALLY 3/4" X 24" IRON REBARS), UNLESS OTHERWISE NOTED, AND WILL BE PLACED PRIOR TO THE COMPLETION OF THE PROJECT.

ALL RIGHT-OF-WAY LINES DEPICTED IN THE NON-ACQUISITION AREAS ARE INTENDED TO RE-ESTABLISH EXISTING RIGHT-OF-WAY LINES AS DETERMINED FROM PREVIOUS PROJECTS, OTHER RECORDED DOCUMENTS, OR FROM CENTERLINE OF EXISTING PAVEMENTS.

RIGHT-OF-WAY BOUNDARIES ARE DEFINED WITH COURSES OF THE PERIMETER OF THE HIGHWAY LANDS REFERENCED TO THE U.S. PUBLIC LAND SURVEY SYSTEM OR OTHER "SURVEYS" OF PUBLIC RECORD.

DIMENSIONING FOR THE NEW RIGHT-OF-WAY IS MEASURED ALONG AND PERPENDICULAR TO THE NEW REFERENCE LINES.

PROPERTY LINES SHOWN ON THIS PLAT ARE DRAWN FROM DATA DERIVED FROM MAPS AND DOCUMENTS OF PUBLIC RECORD AND/OR EXISTING OCCUPATIONAL LINES. THIS PLAT MAY NOT BE A TRUE REPRESENTATION OF EXISTING PROPERTY LINES, EXCLUDING RIGHT-OF-WAY, AND SHOULD NOT BE USED AS A SUBSTITUTE FOR AN ACCURATE FIELD SURVEY.

FOR THE LATEST ACCESS/DRIVEWAY INFORMATION, CONTACT THE KEWAUNEE COUNTY HIGHWAY DEPARTMENT.

PARCEL AND IDENTIFICATION NUMBERS MAY NOT POINT TO ALL AREAS OF ACQUISITION, AS NOTED ON THE TPP DETAIL PAGES.

INFORMATION FOR THE BASIS OF EXISTING HIGHWAY RIGHT-OF-WAY POINTS OF REFERENCE AND ACCESS CONTROL ARE LISTED ON THE TPP DETAIL PAGES.



TRANSPORTATION PROJECT PLAT NO: 4390-07-71-4.02

THAT PART OF LOT 1 OF CERTIFIED SURVEY MAP NO. 91, VOLUME 1 OF CERTIFIED SURVEY MAPS, ON PAGE 97, DOCUMENT NO. 226140, AND PART OF THE NORTHWEST 1/4 OF THE NORTHWEST 1/4, AND PART OF THE SOUTHWEST 1/4 OF THE NORTHWEST 1/4, AND PART OF THE SOUTHEAST 1/4 OF THE NORTHWEST 1/4, ALL IN SECTION 14, TOWNSHIP 23 NORTH, RANGE 24 EAST, IN THE TOWN OF WEST KEWAUNEE, KEWAUNEE COUNTY, WISCONSIN.



480177  
REVISIONS FOR REGISTER OF DEEDS  
PROJECT NUMBER 4390-07-71-4.02  
SHEET 1 OF 1

SCHEDULE OF LANDS & INTERESTS REQUIRED

PARCEL NUMBER	OWNER(S)	INTEREST(S)		
		REQUIRED	EXISTING	TITLE
2	EUGENE G. AND JOANNA M. LEMON	0.089	0.640	0.729
3	STATE OF WISCONSIN	TILE		0.058

OWNERS NAMES ARE SHOWN FOR REFERENCE PURPOSES ONLY AND ARE SUBJECT TO CHANGE PRIOR TO THE TRANSFER OF LAND INTERESTS TO THE DEPARTMENT. PURPOSE OF ALL THE TILES IS FOR GRADING, UNLESS NOTED.

- RELOCATION ORDER CTH 'C' - KEWAUNEE COUNTY
- TO PROPERTY ESTABLISH, LAY OUT, WIDEN, ENLARGE, EXTEND, RECONSTRUCT, IMPROVE, OR MAINTAIN A PORTION OF THE HIGHWAY DESIGNATED ABOVE, THE KEWAUNEE COUNTY HIGHWAY DEPARTMENT DEEMS IT NECESSARY TO RELOCATE OR CHANGE SAID HIGHWAY AND ACQUIRE CERTAIN LANDS AND INTERESTS OR RIGHTS IN LANDS FOR THE ABOVE PROJECT. TO EFFECT THIS CHANGE, PURSUANT TO AUTHORITY GRANTED UNDER SECTION 83.07 AND 83.08, WISCONSIN STATUTES, THE KEWAUNEE COUNTY HIGHWAY DEPARTMENT HEREBY ORDERS THAT:
  - THAT PORTION OF SAID HIGHWAY AS SHOWN ON THIS PLAT IS LAY OUT AND ESTABLISHED TO THE LINES AND WIDTHS AS SO SHOWN FOR THE ABOVE PROJECT.
  - THE LANDS OR INTERESTS OR RIGHTS IN LANDS AS SHOWN ON THIS PLAT ARE REQUIRED BY THE DEPARTMENT FOR THE ABOVE PROJECT AND SHALL BE ACQUIRED IN THE NAME OF KEWAUNEE COUNTY, PURSUANT TO THE PROVISIONS OF SECTION 83.07 AND 83.08, WISCONSIN STATUTES.

COURSE TABLE

COURSE	BEARING	DISTANCE
201-202	S31° 04' 40"E	434.00'
202-203	N58° 55' 20"E	16.25'
203-204	S36° 59' 15"E	97.13'
204-205	S30° 47' 20"E	31.77'
205-206	S20° 50' 56"E	50.41'
206-226	S89° 45' 15"W	11.27'
226-207	SEE CURVE TABLE C1	
207-208	S20° 35' 15"E	219.95'
208-209	SEE CURVE TABLE C2	
209-210	S35° 21' 49"E	103.97'
210-211	SEE CURVE TABLE C3	
211-212	S22° 53' 14"E	465.46'
212-213	S24° 05' 12"E	194.46'
213-214	SEE CURVE TABLE C4	
214-215	S37° 29' 01"E	12.69'
216-217	SEE CURVE TABLE C5	
217-218	N24° 05' 12"W	195.15'
218-219	N27° 53' 14"W	466.15'
219-220	SEE CURVE TABLE C6	
220-221	N35° 21' 49"W	103.97'
221-222	SEE CURVE TABLE C7	
222-223	N20° 35' 15"W	219.95'
223-224	SEE CURVE TABLE C8	
224-225	N89° 45' 15"E	9.79'
225-200	N31° 04' 40"W	601.75'

R/W CURVE TABLE

CURVE	LENGTH	RADIUS	LONG CHORD	LONG CHORD BEARING
C1	503.41'	3133.00'	502.87'	S25° 11' 26"E
C2	290.74'	1127.50'	289.94'	S27° 58' 29"E
C3	217.29'	998.00'	216.86'	S39° 07' 29"E
C4	335.54'	1435.00'	334.77'	S30° 47' 07"E
C5	313.79'	1501.00'	313.22'	N30° 04' 32"W
C6	202.92'	932.00'	202.52'	N29° 07' 29"W
C7	307.76'	1193.50'	306.91'	N27° 58' 29"W
C8	530.35'	3067.00'	529.69'	N25° 32' 29"W

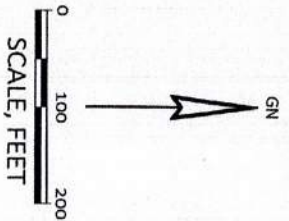
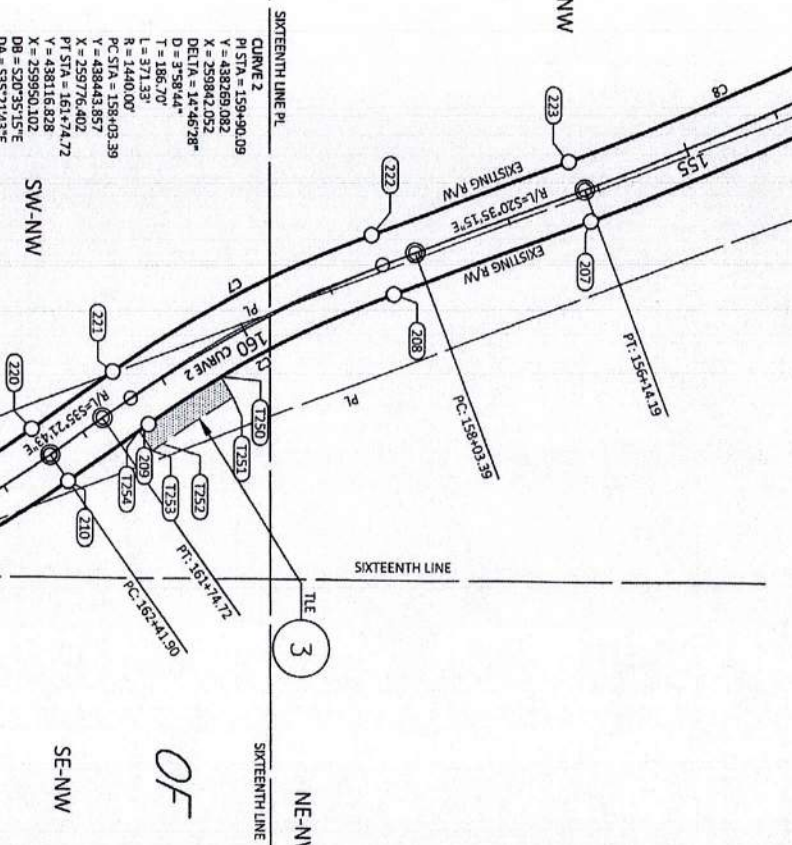

NOTES:  
POSITIONS SHOWN ON THIS PLAT ARE WISCONSIN COORDINATE REFERENCE SYSTEM COORDINATES (NAD83), KEWAUNEE COUNTY, MADISON2011, IN U.S. SURVEY FEET. VALUES ARE GRID COORDINATES, GRID BEARINGS, AND GRID DISTANCES. GRID DISTANCES MAY BE USED AS GROUND DISTANCES.

ALL NEW RIGHT-OF-WAY MONUMENTS WILL BE TYPE 2 (TYPICALLY 3/4" X 2 1/4" IRON REBAR), UNLESS OTHERWISE NOTED, AND WILL BE PLACED PRIOR TO THE COMPLETION OF THE PROJECT.  
FOR THE LATEST ACCESS/DRIVEWAY INFORMATION, CONTACT THE KEWAUNEE COUNTY HIGHWAY DEPARTMENT.  
ALL EXISTING IRON PINS ARE 3/4" CAPPED REBARS UNLESS OTHERWISE NOTED.  
EXISTING HIGHWAY RIGHT-OF-WAY SHOWN HEREIN IS BASED ON THE FOLLOWING POINTS OF REFERENCE:  
CH C - RIGHT OF WAY PROJECT 4390-3-71, CSM 91  
FOR ADDITIONAL INFORMATION REFER TO THE TITLE SHEET, RECORDED AS SHEET 2 OF 2 OF DOCUMENT NUMBER 480137.

STATION & OFFSET TABLE

POINT	STATION	OFFSET
200	144+86.46	25.75'RT
201	145+16.00	23.75'RT
202	149+50.00	23.75'RT
203	149+50.00	40.00'RT
204	150+46.61	50.00'RT
205	150+77.87	50.00'RT
206	151+26.91	41.94'LT
208	158+40.47	32.53'LT
209	161+37.64	32.53'LT
210	162+42.43	33.00'LT
211	164+52.56	33.00'LT
212	169+18.41	33.00'LT
213	171+13.56	33.00'LT
214	174+69.44	33.00'LT
215	174+69.44	33.00'LT

STATION & OFFSET TABLE

POINT	STATION	OFFSET
216	174+20.45	33.00'RT
217	171+13.56	33.00'RT
218	169+18.76	33.00'RT
219	164+52.53	33.00'RT
220	162+42.46	33.00'RT
221	161+39.30	33.45'RT
222	158+38.81	33.45'RT
223	156+19.88	33.00'RT
224	150+83.60	33.94'RT
225	150+88.55	25.47'RT
226	151+21.44	32.13'LT
227	163+91.49	33.02'LT
228	172+76.43	33.00'RT
229	161+44.78	33.32'RT

STATION & OFFSET TABLE

POINT	STATION	OFFSET
7250	160+45.00	30.93'LT
7251	160+45.00	55.93'LT
7252	161+36.97	57.52'LT
7253	161+50.00	57.80'LT
7254	161+50.00	32.59'LT
7255	159+29.89	40.58'RT
7256	149+50.00	40.25'RT
7257	149+50.00	25.75'RT

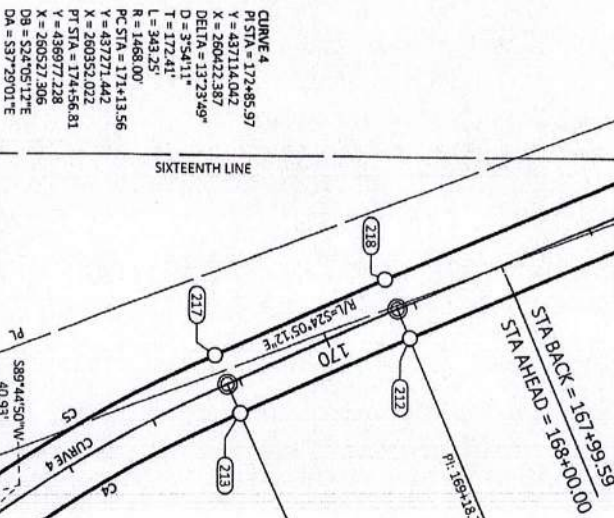

STATION & OFFSET TABLE

POINT	STATION	OFFSET
216	174+20.45	33.00'RT
217	171+13.56	33.00'RT
218	169+18.76	33.00'RT
219	164+52.53	33.00'RT
220	162+42.46	33.00'RT
221	161+39.30	33.45'RT
222	158+38.81	33.45'RT
223	156+19.88	33.00'RT
224	150+83.60	33.94'RT
225	150+88.55	25.47'RT
226	151+21.44	32.13'LT
227	163+91.49	33.02'LT
228	172+76.43	33.00'RT
229	161+44.78	33.32'RT

WEST KEWAUNEE



AYRES ASSOCIATES

JACOB S. JENSEN, PROFESSIONAL LAND SURVEYOR, HEREBY CERTIFY THAT IN FULL COMPLIANCE WITH THE PROVISIONS OF SECTION 84.095 OF THE WISCONSIN STATUTES AND UNDER THE DIRECTION OF KEWAUNEE COUNTY, I HAVE SURVEYED AND MAPPED THIS TRANSPORTATION PROJECT PLAT 4390-07-71-4.02 AND THAT SUCH PLAT CORRECTLY REPRESENTS ALL EXTERIOR BOUNDARIES OF THE SURVEYED LAND.

JULY 17, 2023  
DATE



# TRANSPORTATION PROJECT PLAT NO: 4390-07-71-4.03

THAT PART OF LOT 1 OF CERTIFIED SURVEY MAP NO. 1286, VOLUME 7 OF CERTIFIED SURVEY MAPS, ON PAGE 164, DOCUMENT NO. 420763, AND PART OF THE NORTHEAST 1/4 OF THE SOUTHEAST 1/4, AND THAT PART OF LOT 1 OF CERTIFIED SURVEY MAP NO. 887, VOLUME 5 OF CERTIFIED SURVEY MAPS, ON PAGE 105, DOCUMENT NO. 383766, AND THAT PART OF THE NORTHWEST 1/4 OF THE SOUTHEAST 1/4, AND THAT PART OF LOTS 2-5 OF CERTIFIED SURVEY MAP NO. 569, VOLUME 58 OF CERTIFIED SURVEY MAPS, ON PAGE 569, DOCUMENT NO. 134563, AND THAT PART OF THE SOUTHWEST 1/4 OF THE SOUTHEAST 1/4, ALL IN SECTION 10, TOWNSHIP 23 NORTH, RANGE 24 EAST, IN THE TOWN OF WEST KEWAUNEE, KEWAUNEE COUNTY, WISCONSIN.

PARCEL NUMBER	OWNER(S)	INTEREST(S) REQUIRED	R/W ACRES			
			NEW	EXISTING	TOTAL	PLE
3	STATE OF WISCONSIN	TLE	-----	-----	-----	0.007
4	JOSEPH L. AND SUSAN A. STEINER	TLE	-----	-----	-----	0.032
6	MJ'S FOOTBRIDGE, LLC	PLE, TLE	-----	-----	-----	0.085
7	CTY C LLC	TLE	-----	-----	-----	0.004
8	JASON OBRY	TLE	-----	-----	-----	0.012
9	JULIE M. KLEIMAN	TLE	-----	-----	-----	0.014
11	KELLY R. NIMMER	TLE	-----	-----	-----	0.025
50	AT&T	RELEASE OF RIGHTS	-----	-----	-----	-----
51	WISCONSIN PUBLIC SERVICE - ELECTRIC	RELEASE OF RIGHTS	-----	-----	-----	-----

480178

RECEIVED FOR RECORD  
07/26/2023 1:47:43 PM  
GEORGE L. BERTRAND  
REGISTERED PROFESSIONAL LAND SURVEYOR  
WISCONSIN

RECEIVED 08/07/2023 11:00 AM  
TRANS PROJECT PLAT

RESERVED FOR REGISTER OF DEEDS  
PROJECT NUMBER 4390-07-71- 4.03  
SHEET 1 OF 1

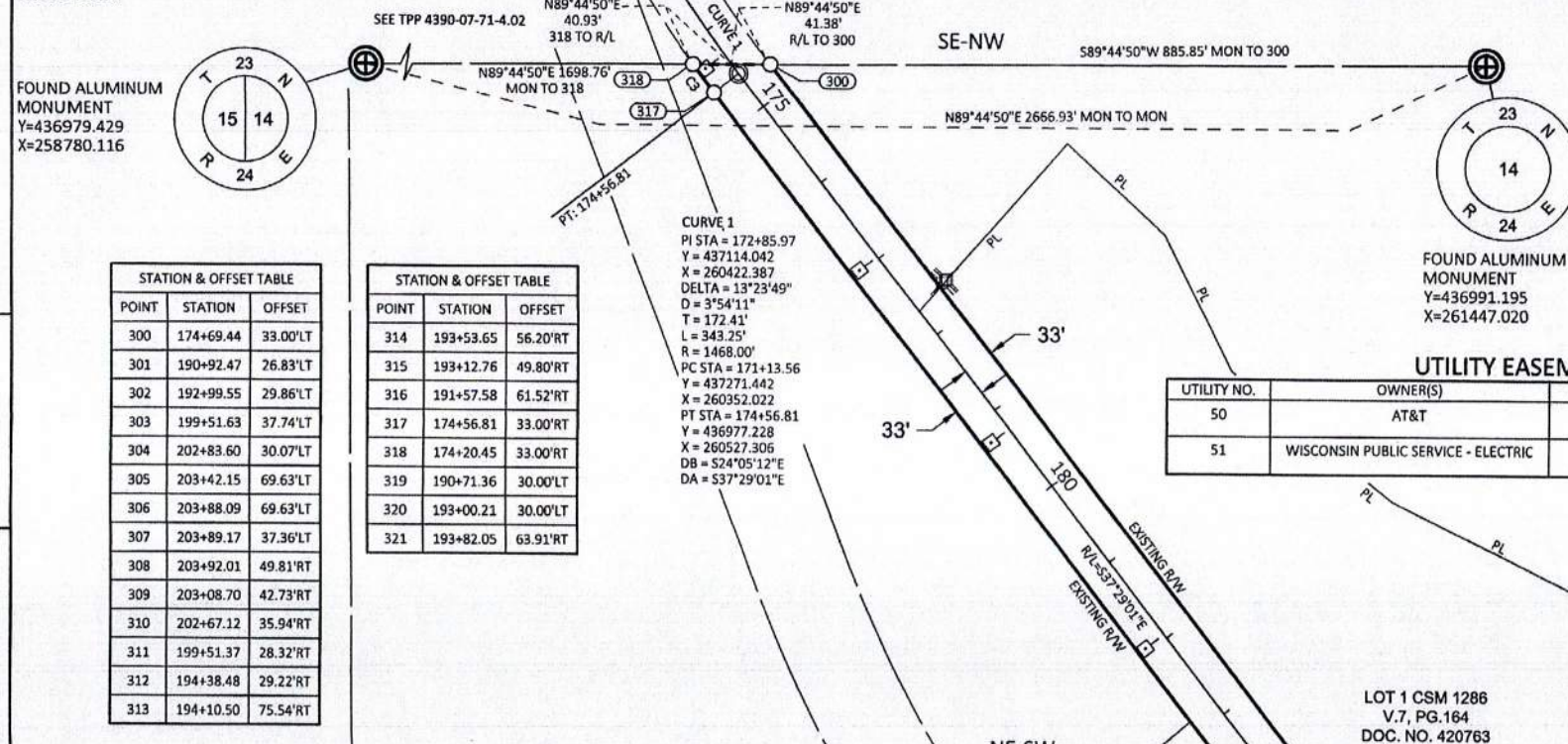

OWNER'S NAMES ARE SHOWN FOR REFERENCE PURPOSES ONLY AND ARE SUBJECT TO CHANGE PRIOR TO THE TRANSFER OF LAND INTERESTS TO THE DEPARTMENT. PURPOSES OF ALL THE TLES IS FOR GRADING, UNLESS NOTED.

UTILITY NO.	OWNER(S)	EASEMENTS
50	AT&T	V.122, P.331, DOC. NO. 210674 - PARCEL 4 NO EASEMENT OF RECORD - PARCEL 11
51	WISCONSIN PUBLIC SERVICE - ELECTRIC	NO EASEMENT OF RECORD - PARCEL 11

COURSE	BEARING	DISTANCE
300-301	S37° 29' 01"E	1617.55'
301-302	SEE CURVE TABLE C1	
302-303	N86° 37' 47"E	645.96'
303-304	S88° 20' 11"E	333.71'
304-305	N57° 46' 41"E	70.69'
305-306	S88° 10' 49"E	45.94'
306-307	S00° 05' 41"E	32.29'
308-309	N83° 19' 28"W	83.61'
309-310	N78° 55' 37"W	42.00'
310-311	N88° 20' 11"W	314.30'
311-312	S86° 37' 47"W	510.57'
312-313	S25° 21' 05"W	54.00'
313-321	N74° 39' 07"W	33.62'
321-314	N77° 44' 15"W	33.89'
314-315	N77° 44' 15"W	47.14'
315-316	SEE CURVE TABLE C2	
316-317	N37° 29' 01"W	1719.75'
317-318	SEE CURVE TABLE C3	

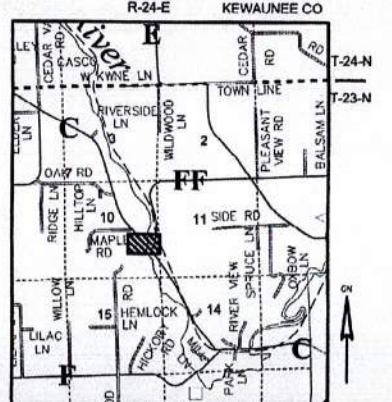

**RELOCATION ORDER CTH "C" - KEWAUNEE COUNTY**

TO PROPERLY ESTABLISH, LAY OUT, WIDEN, ENLARGE, EXTEND, CONSTRUCT, RECONSTRUCT, IMPROVE, OR MAINTAIN A PORTION OF THE HIGHWAY DESIGNATED ABOVE, THE KEWAUNEE COUNTY HIGHWAY DEPARTMENT DEEMS IT NECESSARY TO RELOCATE OR CHANGE SAID HIGHWAY AND ACQUIRE CERTAIN LANDS AND INTERESTS OR RIGHTS IN LANDS FOR THE ABOVE PROJECT.

- TO EFFECT THIS CHANGE, PURSUANT TO AUTHORITY GRANTED UNDER SECTION 83.07 AND 83.08, WISCONSIN STATUTES, THE KEWAUNEE COUNTY HIGHWAY DEPARTMENT HEREBY ORDERS THAT:
- THAT PORTION OF SAID HIGHWAY AS SHOWN ON THIS PLAT IS LAID OUT AND ESTABLISHED TO THE LINES AND WIDTHS AS SO SHOWN FOR THE ABOVE PROJECT.
  - THE LANDS OR INTERESTS OR RIGHTS IN LANDS AS SHOWN ON THIS PLAT ARE REQUIRED BY THE DEPARTMENT FOR THE ABOVE PROJECT AND SHALL BE ACQUIRED IN THE NAME OF KEWAUNEE COUNTY, PURSUANT TO THE PROVISIONS OF SECTION 83.07 AND 83.08, WISCONSIN STATUTES.

**NOTES:**  
POSITIONS SHOWN ON THIS PLAT ARE WISCONSIN COORDINATE REFERENCE SYSTEM COORDINATES (WISCRS), KEWAUNEE COUNTY, NAD83(2011), IN U.S. SURVEY FEET. VALUES ARE GRID COORDINATES, GRID BEARINGS, AND GRID DISTANCES. GRID DISTANCES MAY BE USED AS GROUND DISTANCES.

ALL NEW RIGHT-OF-WAY MONUMENTS WILL BE TYPE 2 (TYPICALLY 3/4" X 24" IRON REBARS), UNLESS OTHERWISE NOTED, AND WILL BE PLACED PRIOR TO THE COMPLETION OF THE PROJECT.

FOR THE LATEST ACCESS/DRIVEWAY INFORMATION, CONTACT THE KEWAUNEE COUNTY HIGHWAY DEPARTMENT.

EXISTING HIGHWAY RIGHT-OF-WAY SHOWN HEREIN IS BASED ON THE FOLLOWING POINTS OF REFERENCE:  
CTH C: RIGHT OF WAY PROJECT E0422(37)/4390/00, CSM 1286, CSM 887  
CTH FF: RIGHT OF WAY PROJECT E0-0(27)

FOR ADDITIONAL INFORMATION REFER TO THE TITLE SHEET, RECORDED AS SHEET 2 OF 2 OF DOCUMENT NUMBER 480137.

POINT	STATION	OFFSET
T351	188+25.00	43.00'LT
T350	188+25.00	33.00'LT
T352	190+00.00	43.00'LT
T353	190+22.11	40.00'LT
T368	193+41.00	53.65'RT
T367	193+46.94	73.84'RT
T354	193+75.00	40.00'LT
T365	194+01.96	89.56'RT
T364	194+11.03	94.06'RT
T355	194+35.00	50.00'LT

POINT	STATION	OFFSET
T363	194+44.06	39.43'RT
T356	194+60.00	36.07'LT
T362	195+00.00	41.18'RT
T361	195+00.00	31.21'RT
T357	198+75.00	35.10'LT
T358	198+75.00	50.10'LT
T359	199+49.85	52.69'LT
T360	199+51.43	37.74'LT

I, JACOB S. JENSEN, PROFESSIONAL LAND SURVEYOR, HEREBY CERTIFY THAT IN FULL COMPLIANCE WITH THE PROVISIONS OF SECTION 84.095 OF THE WISCONSIN STATUTES AND UNDER THE DIRECTION OF KEWAUNEE COUNTY, I HAVE SURVEYED AND MAPPED THIS TRANSPORTATION PROJECT PLAT 4390-07-71-4.03 AND THAT SUCH PLAT CORRECTLY REPRESENTS ALL EXTERIOR BOUNDARIES OF THE SURVEYED LAND.

JACOB S. JENSEN  
REGISTRATION NUMBER: S-2961  
DATE: JULY 17, 2023

THIS PLAT AND RELOCATION ORDER ARE APPROVED FOR KEWAUNEE COUNTY.

TODD EVERY  
KEWAUNEE COUNTY HIGHWAY COMMISSIONER  
DATE: 7-24-23

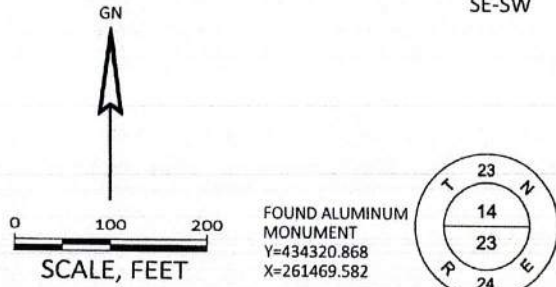

CURVE 2  
PI STA = 192+28.95  
Y = 435570.987  
X = 261605.718  
DELTA = 58°16'52"  
D = 15°26'37"  
T = 206.84'  
L = 377.38'  
R = 371.00'  
PC STA = 190+22.11  
Y = 435735.121  
X = 261479.849  
PT STA = 193+99.49  
Y = 435591.764  
X = 261811.512  
DB = 537°29'01"E  
DA = N84°14'06"E

CURVE 3  
PI STA = 198+47.17  
Y = 435636.731  
X = 262256.925  
DELTA = 7°35'05"  
D = 0°51'19"  
T = 444.12'  
L = 886.94'  
R = 6700.00'  
PC STA = 194+03.05  
Y = 435592.121  
X = 261815.055  
PT STA = 202+89.99  
Y = 435622.628  
X = 262700.817  
DB = N84°14'06"E  
DA = S88°10'49"E



**TRANSPORTATION PROJECT PLAT NO: 4390-07-71-4.05**

THAT PART OF THE SOUTHEAST 1/4 OF THE SOUTHEAST 1/4 OF SECTION 13, TOWNSHIP 23 NORTH, RANGE 24 EAST, IN THE TOWN OF WEST KEWAUNEE, KEWAUNEE COUNTY, WISCONSIN.

**RELOCATION ORDER CTH "C" - KEWAUNEE COUNTY**

TO PROPERLY ESTABLISH, LAY OUT, WIDEN, ENLARGE, EXTEND, CONSTRUCT, RECONSTRUCT, IMPROVE, OR MAINTAIN A PORTION OF THE HIGHWAY DESIGNATED ABOVE, THE KEWAUNEE COUNTY HIGHWAY DEPARTMENT DEEMS IT NECESSARY TO RELOCATE OR CHANGE SAID HIGHWAY AND ACQUIRE CERTAIN LANDS AND INTERESTS OR RIGHTS IN LANDS FOR THE ABOVE PROJECT.

TO EFFECT THIS CHANGE, PURSUANT TO AUTHORITY GRANTED UNDER SECTION 83.07 AND 83.08, WISCONSIN STATUTES, THE KEWAUNEE COUNTY HIGHWAY DEPARTMENT HEREBY ORDERS THAT:

- THAT PORTION OF SAID HIGHWAY AS SHOWN ON THIS PLAT IS LAID OUT AND ESTABLISHED TO THE LINES AND WIDTHS AS SO SHOWN FOR THE ABOVE PROJECT.
- THE LANDS OR INTERESTS OR RIGHTS IN LANDS AS SHOWN ON THIS PLAT ARE REQUIRED BY THE DEPARTMENT FOR THE ABOVE PROJECT AND SHALL BE ACQUIRED IN THE NAME OF KEWAUNEE COUNTY, PURSUANT TO THE PROVISIONS OF SECTION 83.07 AND 83.08, WISCONSIN STATUTES.

SCHEDULE OF LANDS & INTERESTS REQUIRED						
PARCEL NUMBER	OWNER(S)	INTEREST(S) REQUIRED	R/W ACRES			
			NEW	EXISTING	TOTAL	TLE
13	TOWN OF WEST KEWAUNEE	TLE	-----	-----	-----	0.016
14	JEFFREY C. & MICHELLE M. STANGEL	TLE	-----	-----	-----	0.039

OWNER'S NAMES ARE SHOWN FOR REFERENCE PURPOSES ONLY AND ARE SUBJECT TO CHANGE PRIOR TO THE TRANSFER OF LAND INTERESTS TO THE DEPARTMENT. PURPOSED OF ALL THE TLES IS FOR GRADING, UNLESS NOTED.

480179

RECEIVED FOR RECORD  
07/24/2023 1:47:57 PM  
GERMINE L. BERTRAND  
REGISTERED FIELD ENGINEER/KEWAUNEE COUNTY RECORDS

RECEIVED 08/07, STATION 1  
TRAFFIC PROJECT PLAT

RESERVED FOR REGISTER OF DEEDS  
PROJECT NUMBER 4390-07-71- 4.05  
SHEET 1 OF 1

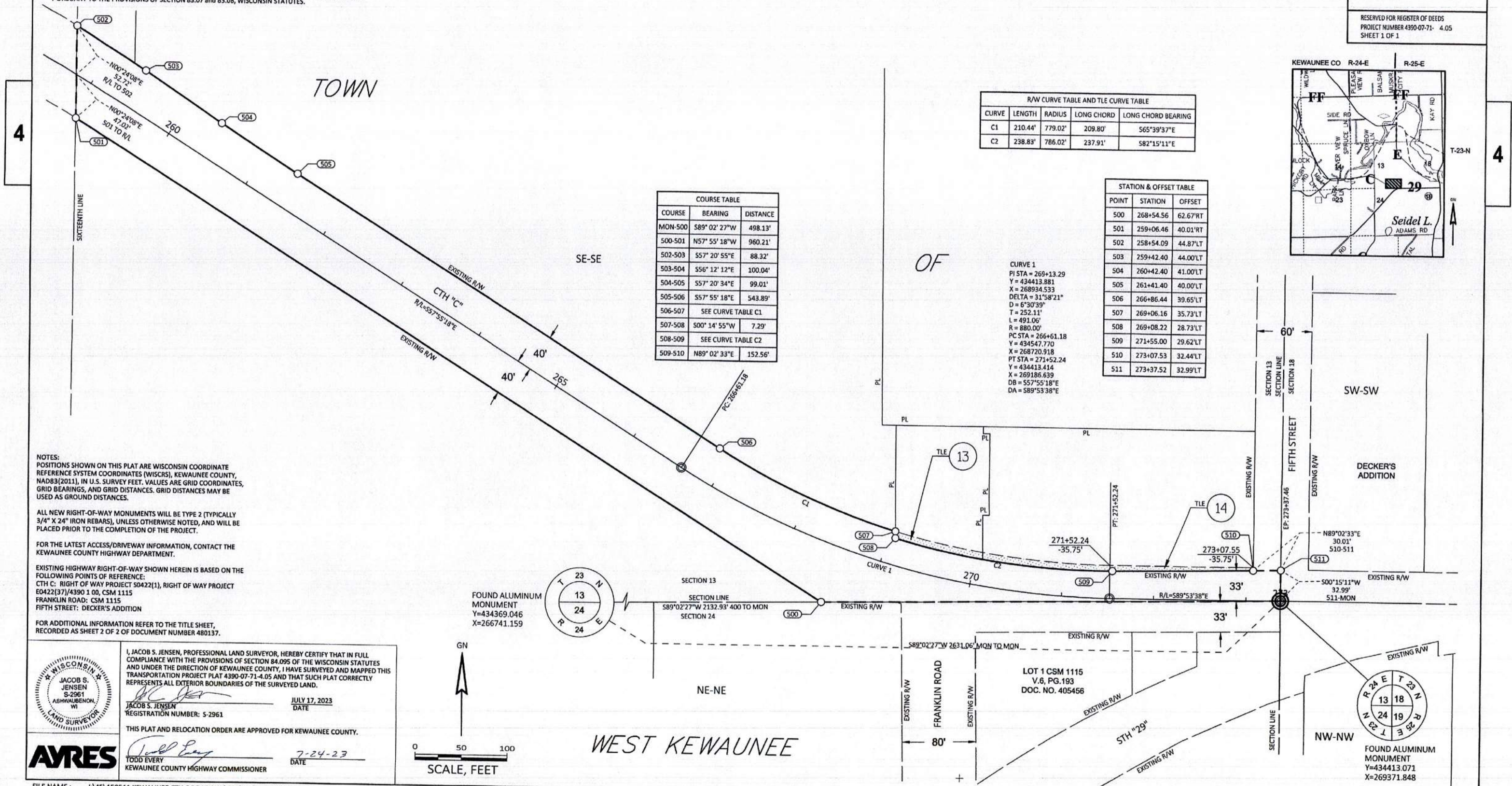

COURSE TABLE		
COURSE	BEARING	DISTANCE
MON-500	S89° 02' 27"W	498.13'
500-501	N57° 55' 18"W	960.21'
502-503	S57° 20' 55"E	88.32'
503-504	S56° 12' 12"E	100.04'
504-505	S57° 20' 34"E	99.01'
505-506	S57° 55' 18"E	543.89'
506-507	SEE CURVE TABLE C1	
507-508	S00° 14' 55"W	7.29'
508-509	SEE CURVE TABLE C2	
509-510	N89° 02' 33"E	152.56'

R/W CURVE TABLE AND TLE CURVE TABLE				
CURVE	LENGTH	RADIUS	LONG CHORD	LONG CHORD BEARING
C1	210.44'	779.02'	209.80'	S65°39'37"E
C2	238.83'	786.02'	237.91'	S82°15'11"E

STATION & OFFSET TABLE		
POINT	STATION	OFFSET
500	268+54.56	62.67'RT
501	259+06.46	40.01'RT
502	258+54.09	44.87'LT
503	259+42.40	44.00'LT
504	260+42.40	41.00'LT
505	261+41.40	40.00'LT
506	266+86.44	39.65'LT
507	269+06.16	35.73'LT
508	269+08.22	28.73'LT
509	271+55.00	29.62'LT
510	273+07.53	32.44'LT
511	273+37.52	32.99'LT

CURVE 1  
PI STA = 269+13.29  
Y = 434413.881  
X = 268934.533  
DELTA = 31°58'21"  
D = 6°30'39"  
T = 252.11'  
L = 491.06'  
R = 880.00'  
PC STA = 266+61.18  
Y = 434547.770  
X = 268720.918  
PT STA = 271+52.24  
Y = 434413.414  
X = 269186.639  
DB = 557°55'18"E  
DA = 589°53'38"E

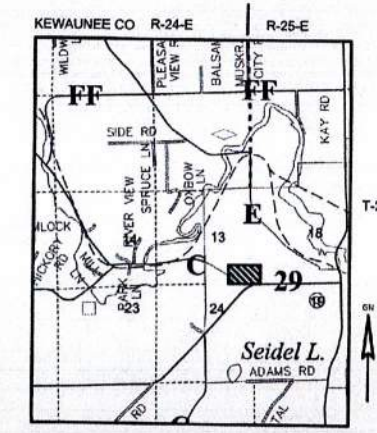

NOTES:  
POSITIONS SHOWN ON THIS PLAT ARE WISCONSIN COORDINATE REFERENCE SYSTEM COORDINATES (WISCRS), KEWAUNEE COUNTY, NAD83(2011), IN U.S. SURVEY FEET. VALUES ARE GRID COORDINATES, GRID BEARINGS, AND GRID DISTANCES. GRID DISTANCES MAY BE USED AS GROUND DISTANCES.

ALL NEW RIGHT-OF-WAY MONUMENTS WILL BE TYPE 2 (TYPICALLY 3/4" X 24" IRON REBARS), UNLESS OTHERWISE NOTED, AND WILL BE PLACED PRIOR TO THE COMPLETION OF THE PROJECT.

FOR THE LATEST ACCESS/DRIVEWAY INFORMATION, CONTACT THE KEWAUNEE COUNTY HIGHWAY DEPARTMENT.

EXISTING HIGHWAY RIGHT-OF-WAY SHOWN HEREIN IS BASED ON THE FOLLOWING POINTS OF REFERENCE:  
CTH C: RIGHT OF WAY PROJECT S0422(1), RIGHT OF WAY PROJECT E0422(37)/4390 1 00, CSM 1115  
FRANKLIN ROAD: CSM 1115  
FIFTH STREET: DECKER'S ADDITION

FOR ADDITIONAL INFORMATION REFER TO THE TITLE SHEET, RECORDED AS SHEET 2 OF 2 OF DOCUMENT NUMBER 480137.

I, JACOB S. JENSEN, PROFESSIONAL LAND SURVEYOR, HEREBY CERTIFY THAT IN FULL COMPLIANCE WITH THE PROVISIONS OF SECTION 84.095 OF THE WISCONSIN STATUTES AND UNDER THE DIRECTION OF KEWAUNEE COUNTY, I HAVE SURVEYED AND MAPPED THIS TRANSPORTATION PROJECT PLAT 4390-07-71-4.05 AND THAT SUCH PLAT CORRECTLY REPRESENTS ALL EXTERIOR BOUNDARIES OF THE SURVEYED LAND.

JACOB S. JENSEN  
REGISTRATION NUMBER: S-2961  
DATE: JULY 17, 2023

THIS PLAT AND RELOCATION ORDER ARE APPROVED FOR KEWAUNEE COUNTY.

TODD EVERY  
KEWAUNEE COUNTY HIGHWAY COMMISSIONER  
DATE: 7-24-23

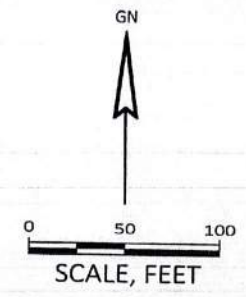



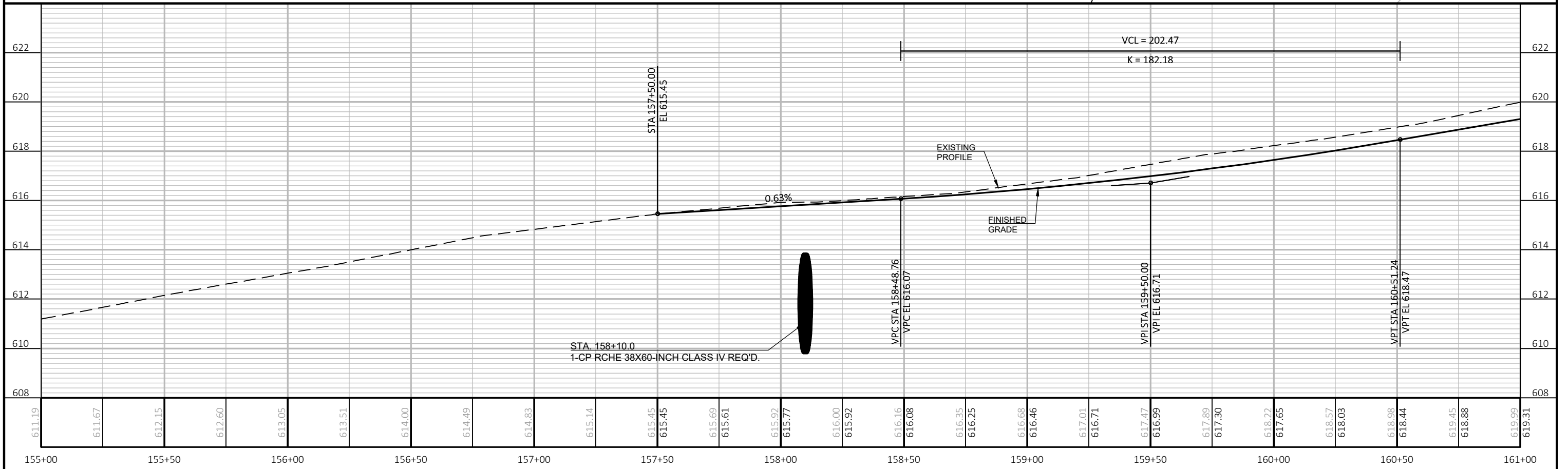
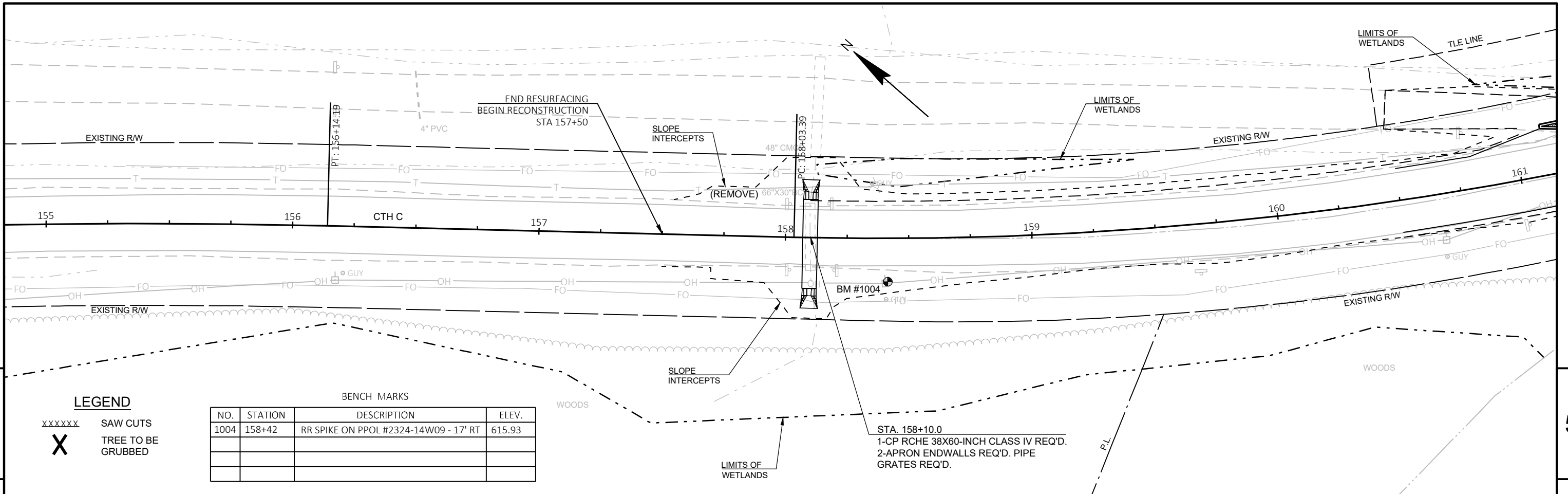

PROJECT NO: 4390-07-71      HWY: CTH C      COUNTY: KEWAUNEE      PLAN AND PROFILE: CTH C      SHEET: 5

**LEGEND**

XXXXXX SAW CUTS  
 X TREE TO BE GRUBBED

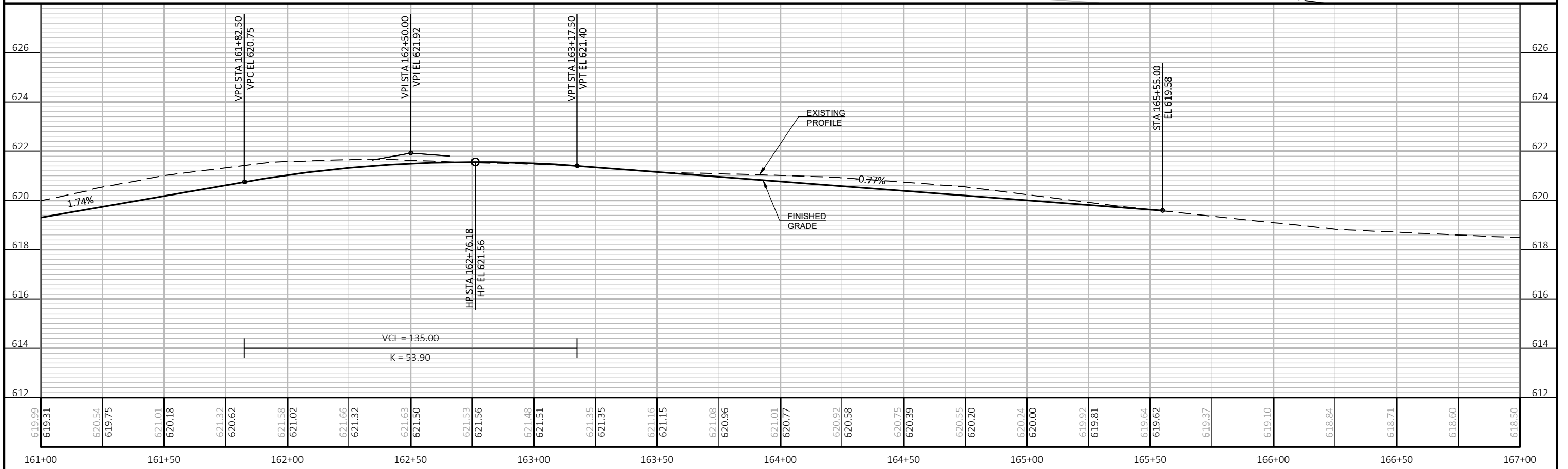
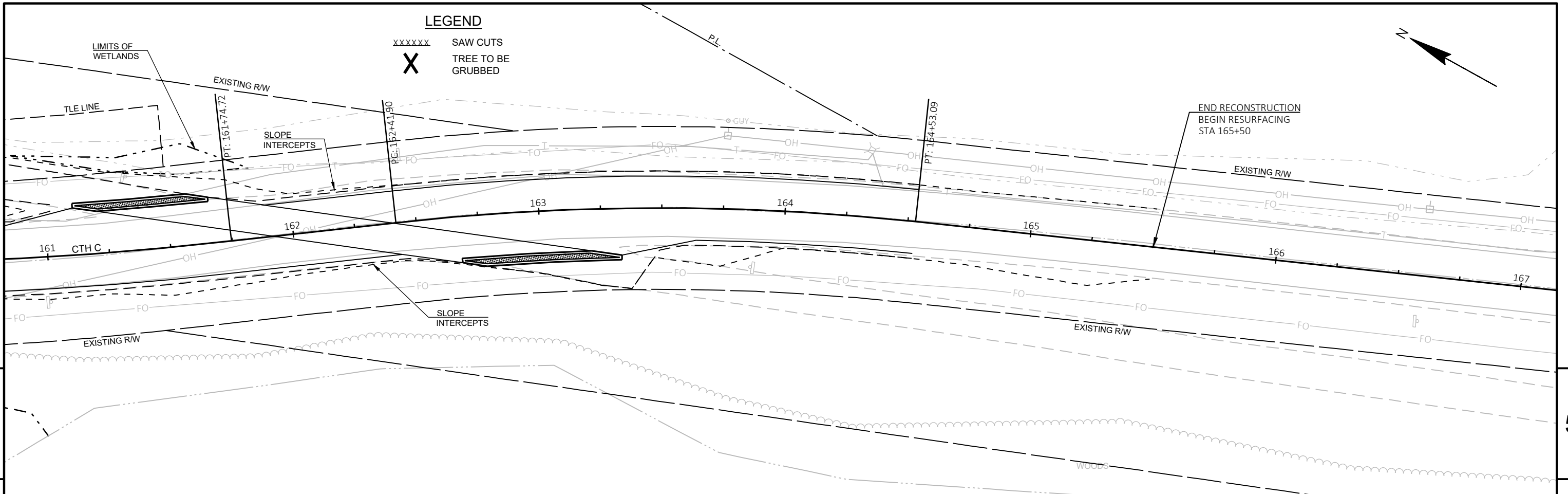
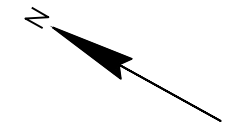

PROJECT NO: 4390-07-71	HWY: CTH C	COUNTY: KEWAUNEE	PLAN AND PROFILE: CTH C	SHEET	<b>E</b>
------------------------	------------	------------------	-------------------------	-------	----------

**LEGEND**

- XXXXXX SAW CUTS
- X TREE TO BE GRUBBED

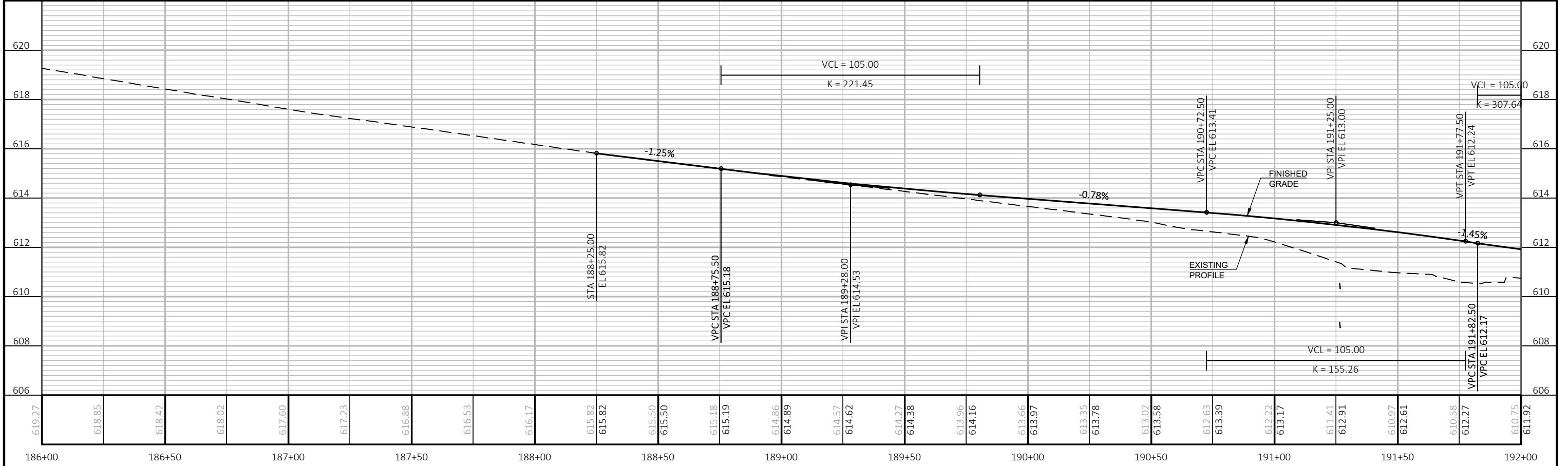
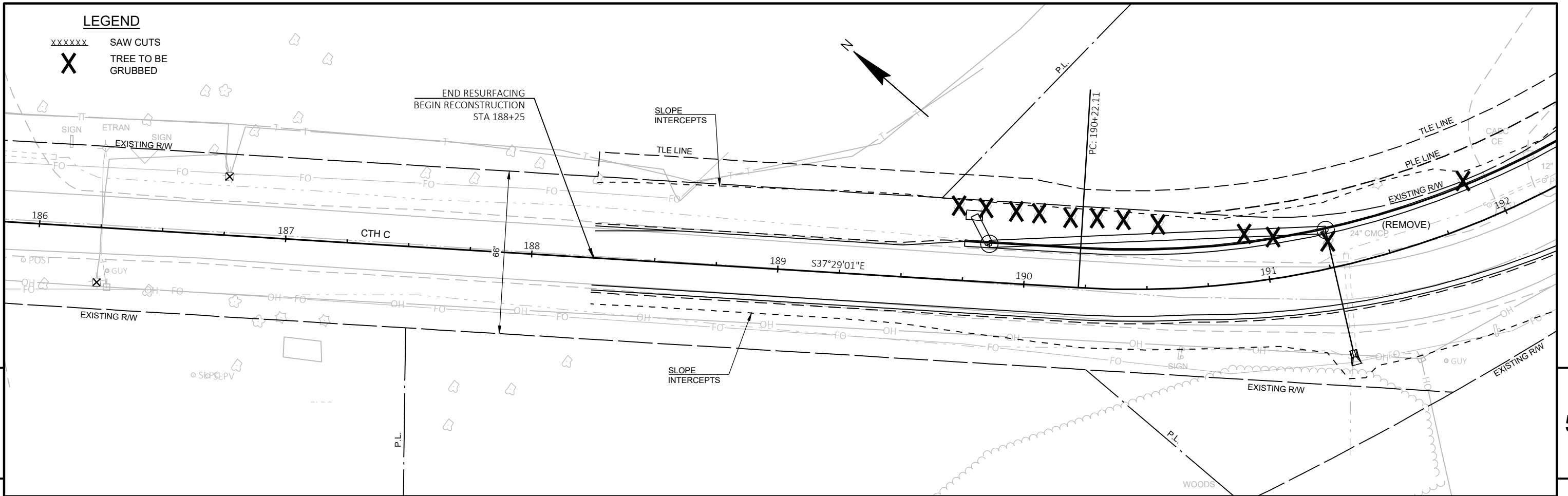

PROJECT NO: 4390-07-71	HWY: CTH C	COUNTY: KEWAUNEE	PLAN AND PROFILE: CTH C
SHEET			<b>E</b>

**LEGEND**

XXXXXX SAW CUTS  
 X TREE TO BE GRUBBED

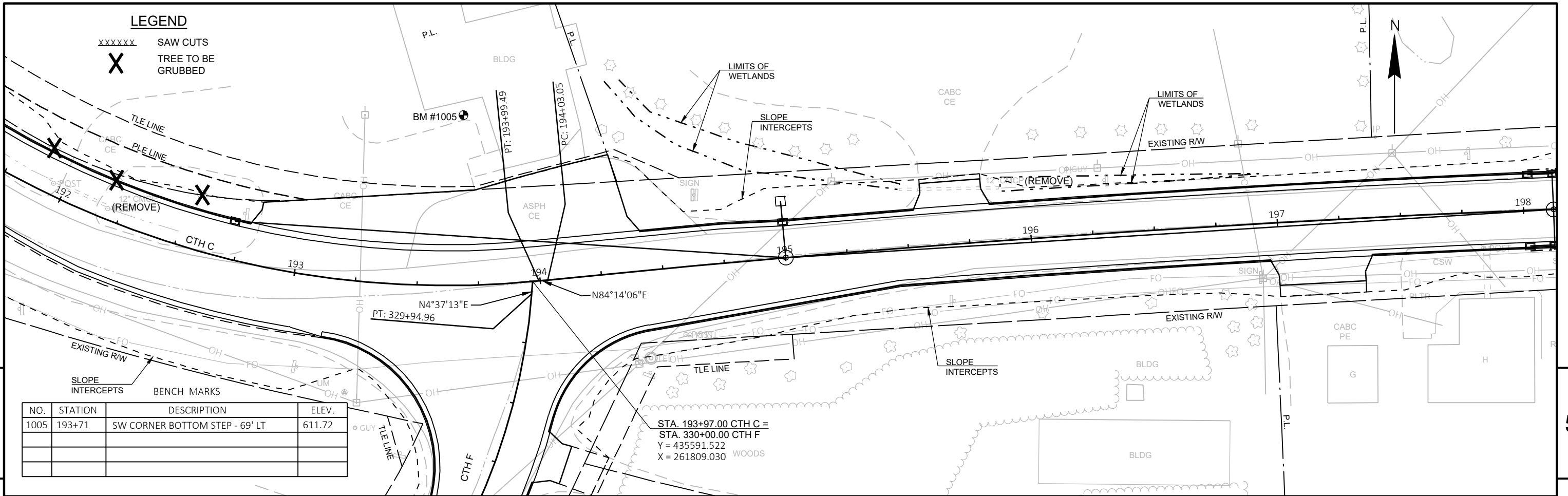

NO.	STATION	DESCRIPTION	ELEV.
1005	193+71	SW CORNER BOTTOM STEP - 69' LT	611.72

STA. 193+97.00 CTH C =  
 STA. 330+00.00 CTH F  
 Y = 435591.522  
 X = 261809.030

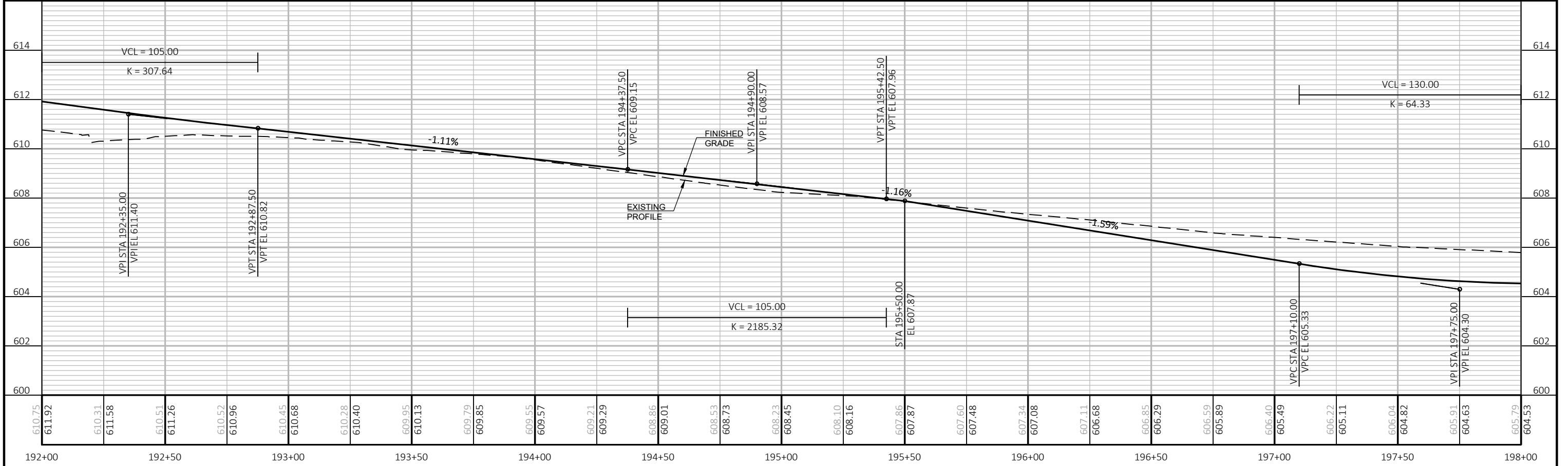

PROJECT NO: 4390-07-71	HWY: CTH C	COUNTY: KEWAUNEE	PLAN AND PROFILE: CTH C	SHEET	<b>E</b>
------------------------	------------	------------------	-------------------------	-------	----------



**LEGEND**

- XXXXXX SAW CUTS
- X TREE TO BE GRUBBED

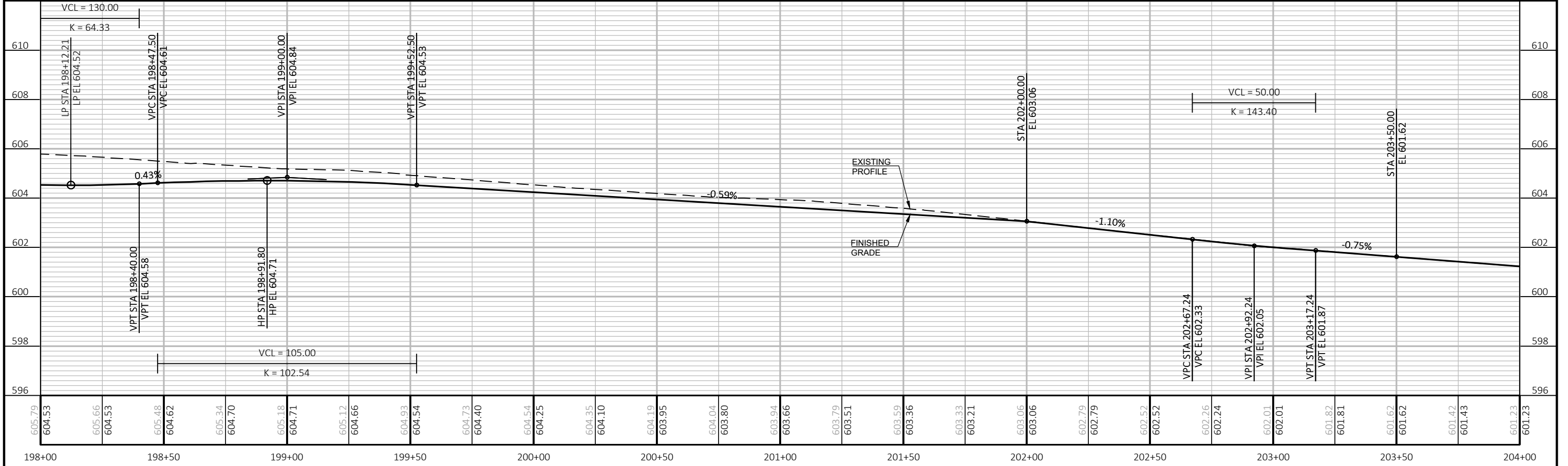
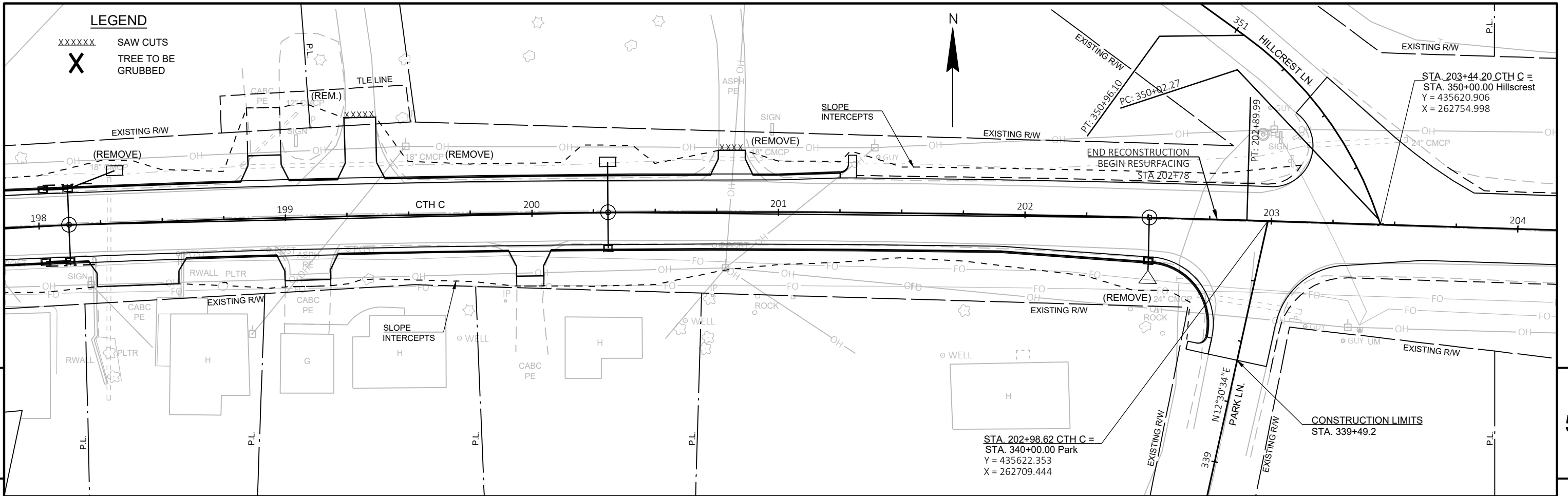

PROJECT NO: 4390-07-71	HWY: CTH C	COUNTY: KEWAUNEE	PLAN AND PROFILE: CTH C	SHEET	<b>E</b>
------------------------	------------	------------------	-------------------------	-------	----------

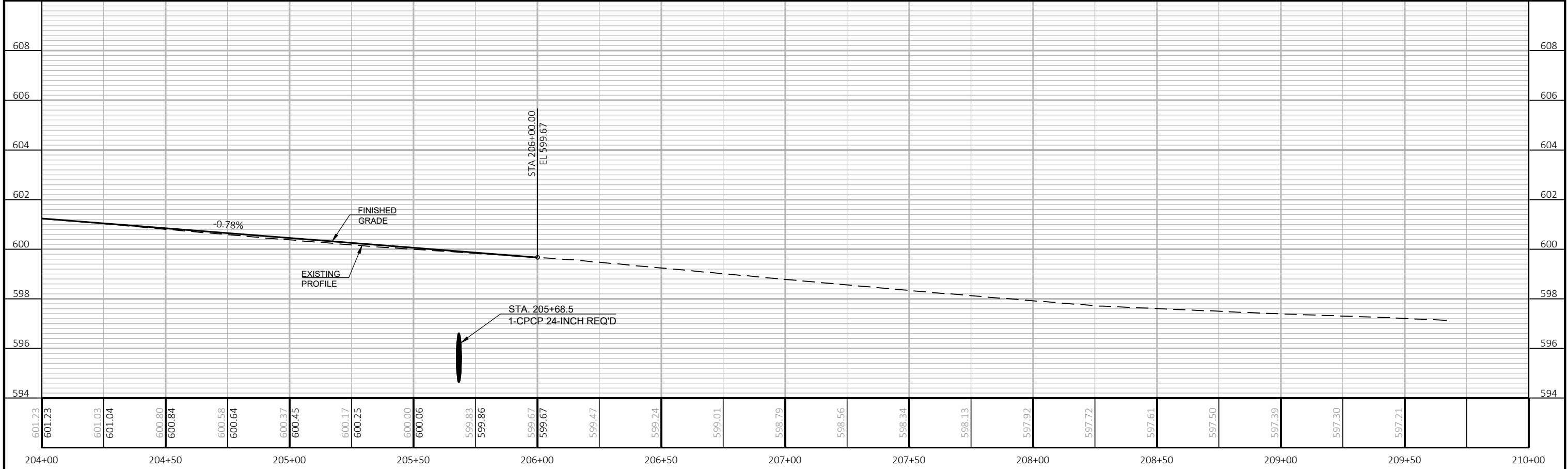
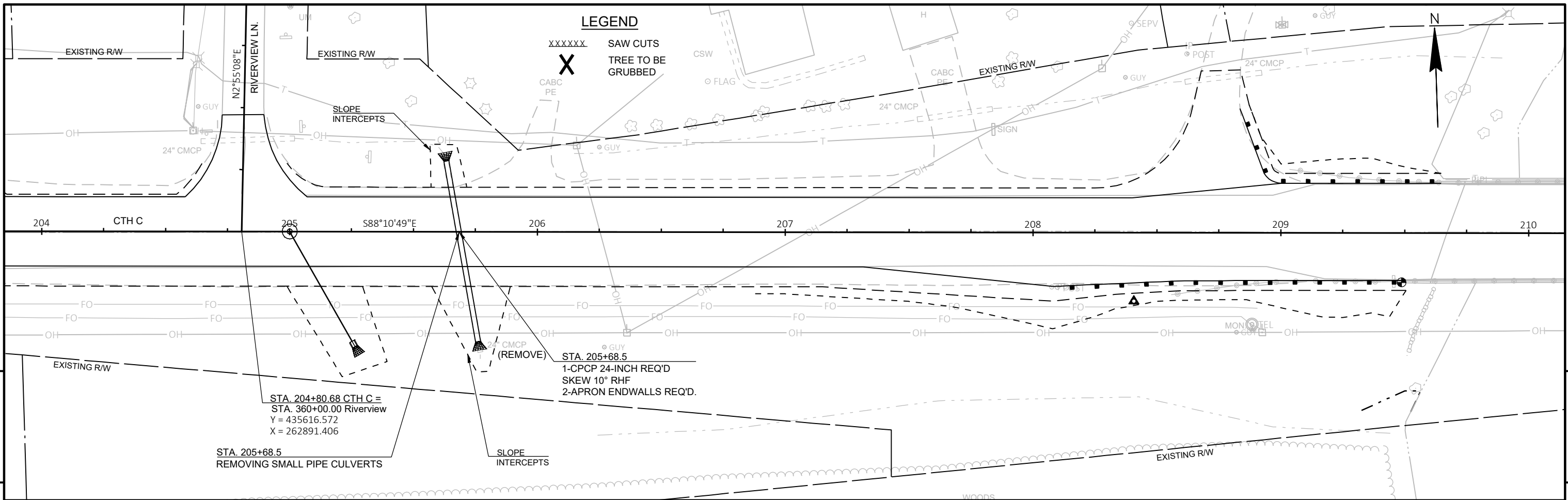

PROJECT NO: 4390-07-71	HWY: CTH C	COUNTY: KEWAUNEE	PLAN AND PROFILE: CTH C	SHEET 5
------------------------	------------	------------------	-------------------------	---------

BENCH MARKS			
NO.	STATION	DESCRIPTION	ELEV.
1005	193+71	SW CORNER BOTTOM STEP - 69' LT	611.72

**LEGEND**  
 XXXXXX SAW CUTS  
 X TREE TO BE GRUBBED

CP #902  
 STA 327+92.85, 41.27' LT  
 Y=435439.441  
 X=261689.349  
 RR SPIKE

STA. 193+97.00 CTH C =  
 STA. 330+00.00 CTH F  
 Y = 435591.522  
 X = 261809.030

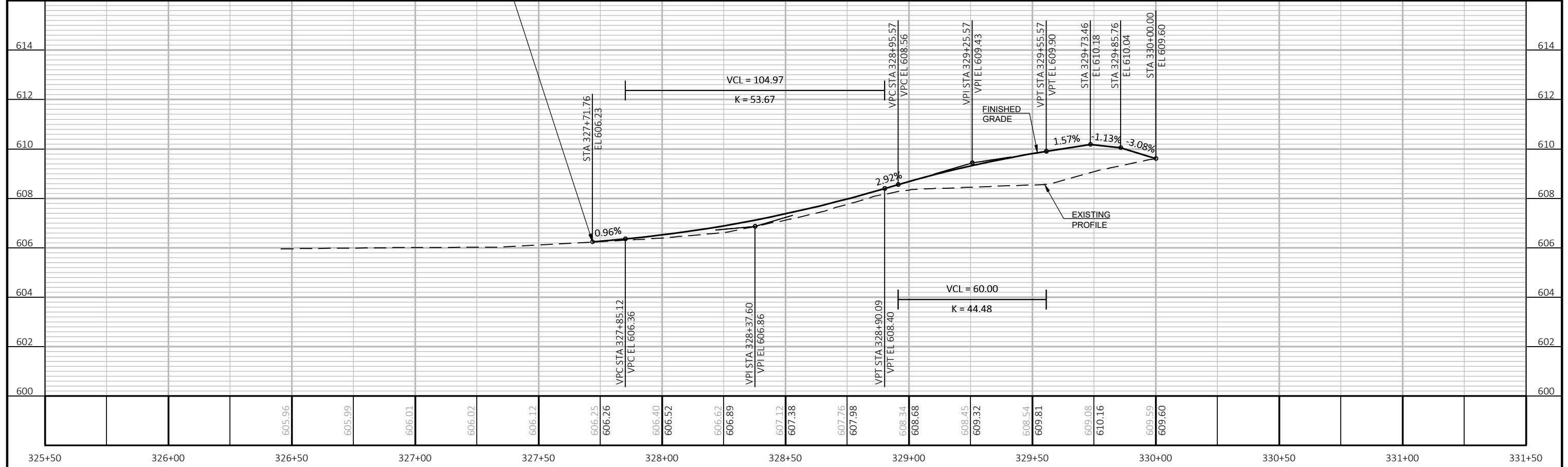
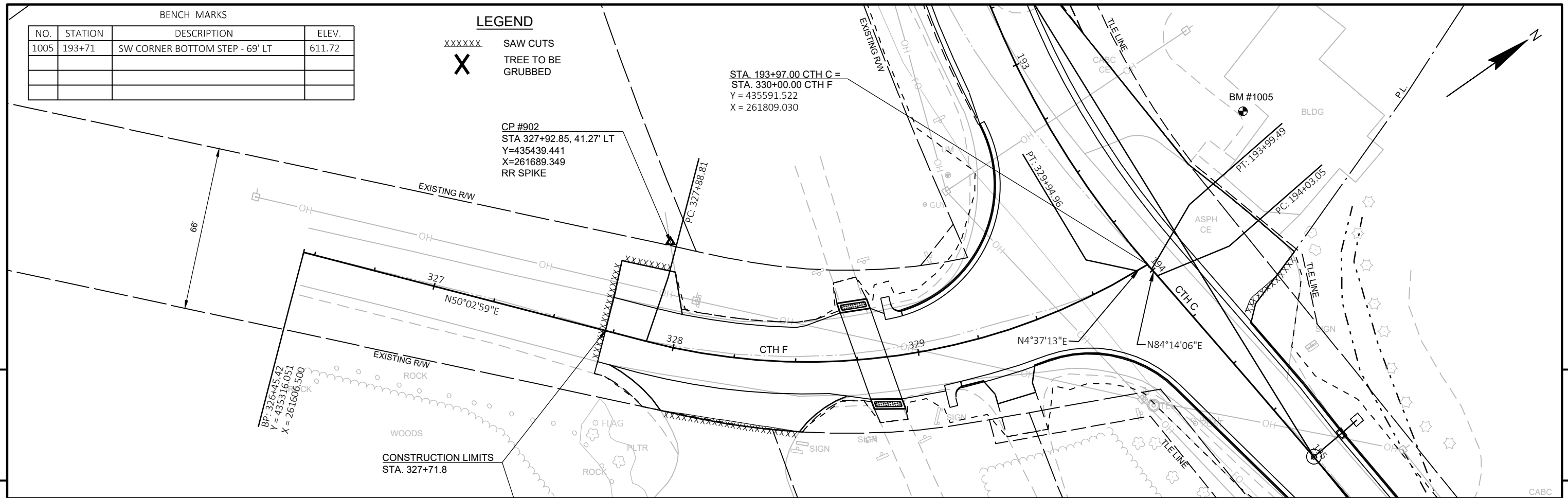

PROJECT NO: 4390-07-71	HWY: CTH C	COUNTY: KEWAUNEE	PLAN AND PROFILE: CTH F	SHEET E
------------------------	------------	------------------	-------------------------	---------

**LEGEND**

XXXXXX SAW CUTS

**BENCH MARKS**

NO.	STATION	DESCRIPTION	ELEV.
1001	112+58	RR SPIKE ON E FACE OF PPOL - 40' RT	622.75

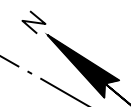

5

5

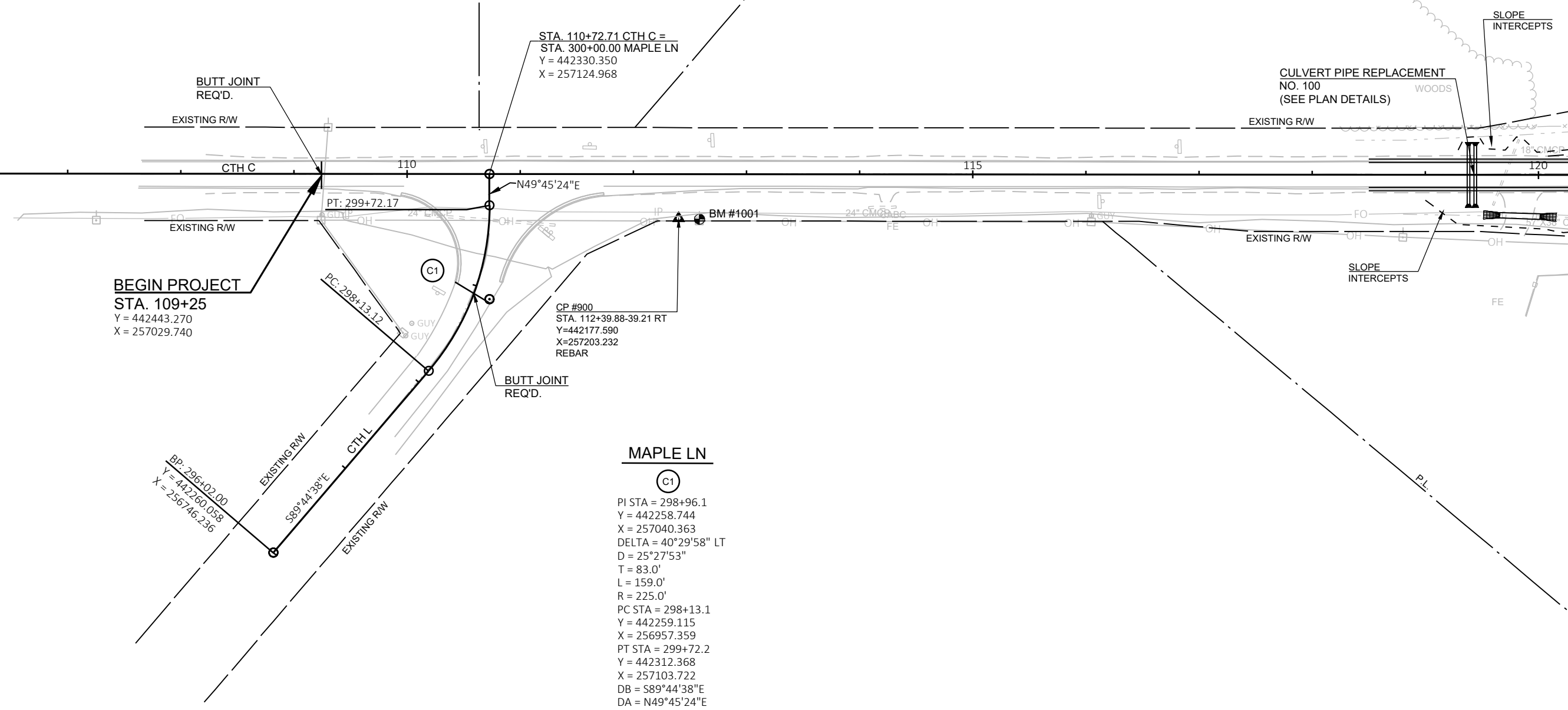

**BEGIN PROJECT**  
 STA. 109+25  
 Y = 442443.270  
 X = 257029.740

STA. 110+72.71 CTH C =  
 STA. 300+00.00 MAPLE LN  
 Y = 442330.350  
 X = 257124.968

CP #900  
 STA. 112+39.88-39.21 RT  
 Y=442177.590  
 X=257203.232  
 REBAR

**MAPLE LN**

(C1)  
 PI STA = 298+96.1  
 Y = 442258.744  
 X = 257040.363  
 DELTA = 40°29'58" LT  
 D = 25°27'53"  
 T = 83.0'  
 L = 159.0'  
 R = 225.0'  
 PC STA = 298+13.1  
 Y = 442259.115  
 X = 256957.359  
 PT STA = 299+72.2  
 Y = 442312.368  
 X = 257103.722  
 DB = S89°44'38"E  
 DA = N49°45'24"E

**LEGEND**

XXXXXX SAW CUTS

**CTH FF**

(C2)  
 PI STA = 312+23.8  
 Y = 441298.184  
 X = 258286.327  
 DELTA = 17°05'51" LT  
 D = 6°44'26"  
 T = 127.8'  
 L = 253.6'  
 R = 850.0'  
 PC STA = 310+96.0  
 Y = 441201.070  
 X = 258203.292  
 PT STA = 313+49.7  
 Y = 441415.418  
 X = 258337.141  
 DB = N40°31'53"E  
 DA = N23°26'02"E

**BENCH MARKS**

NO.	STATION	DESCRIPTION	ELEV.
1002	123+24	3 1/2" ALLUMINUM CAP - 17' LT	611.28

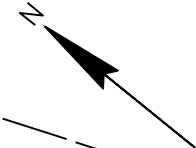

5

5

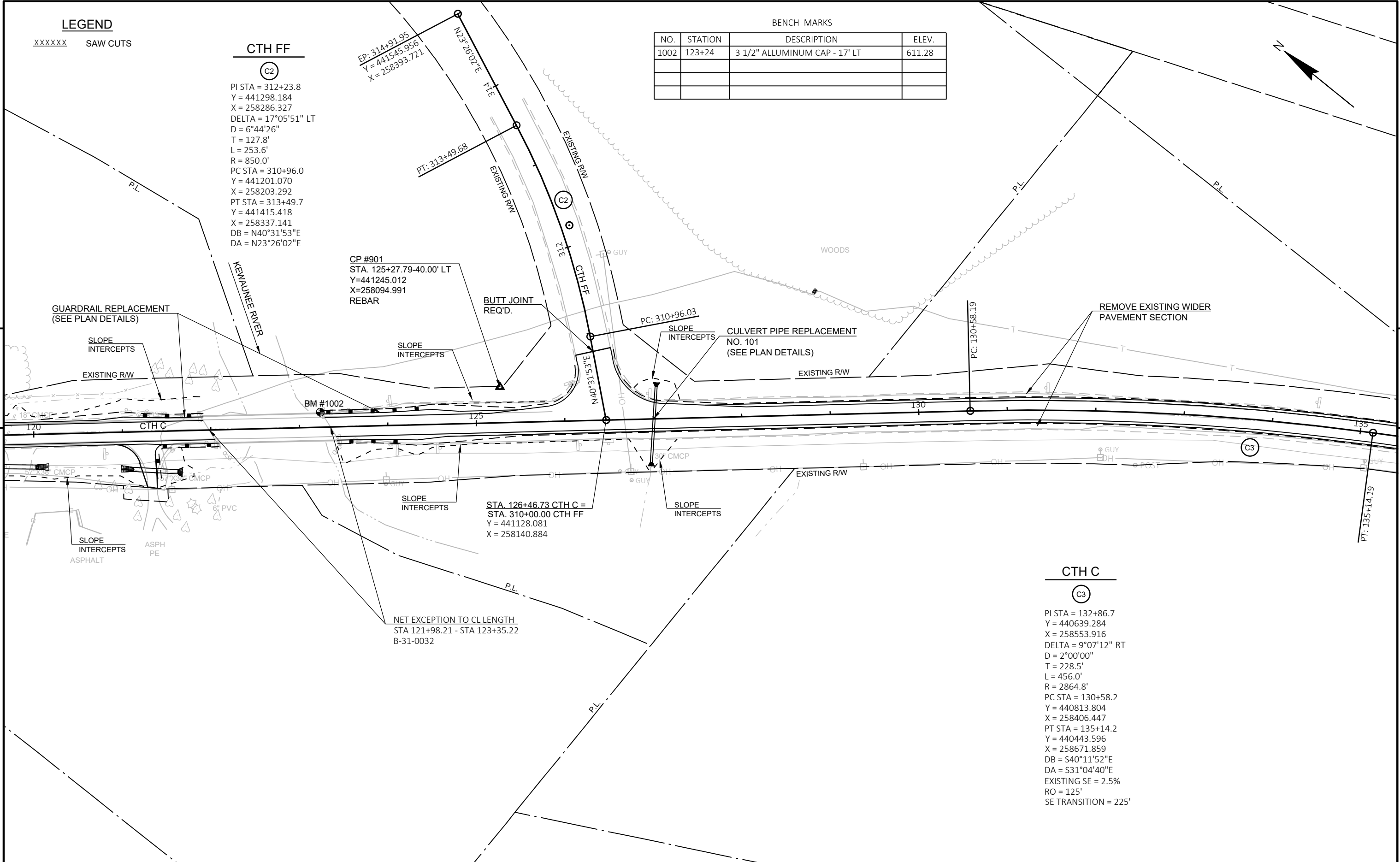

CP #901  
 STA. 125+27.79-40.00' LT  
 Y=441245.012  
 X=258094.991  
 REBAR

BUTT JOINT  
 REQ'D.

CULVERT PIPE REPLACEMENT  
 NO. 101  
 (SEE PLAN DETAILS)

REMOVE EXISTING WIDER  
 PAVEMENT SECTION

STA. 126+46.73 CTH C =  
 STA. 310+00.00 CTH FF  
 Y = 441128.081  
 X = 258140.884

NET EXCEPTION TO CL LENGTH  
 STA 121+98.21 - STA 123+35.22  
 B-31-0032

**CTH C**

(C3)  
 PI STA = 132+86.7  
 Y = 440639.284  
 X = 258553.916  
 DELTA = 9°07'12" RT  
 D = 2°00'00"  
 T = 228.5'  
 L = 456.0'  
 R = 2864.8'  
 PC STA = 130+58.2  
 Y = 440813.804  
 X = 258406.447  
 PT STA = 135+14.2  
 Y = 440443.596  
 X = 258671.859  
 DB = S40°11'52"E  
 DA = S31°04'40"E  
 EXISTING SE = 2.5%  
 RO = 125'  
 SE TRANSITION = 225'

**LEGEND**

XXXXXX SAW CUTS

**BENCH MARKS**

NO.	STATION	DESCRIPTION	ELEV.
1003	147+22	RR SPIKE ON PPOL #2324-14W14 - 23' RT	609.26

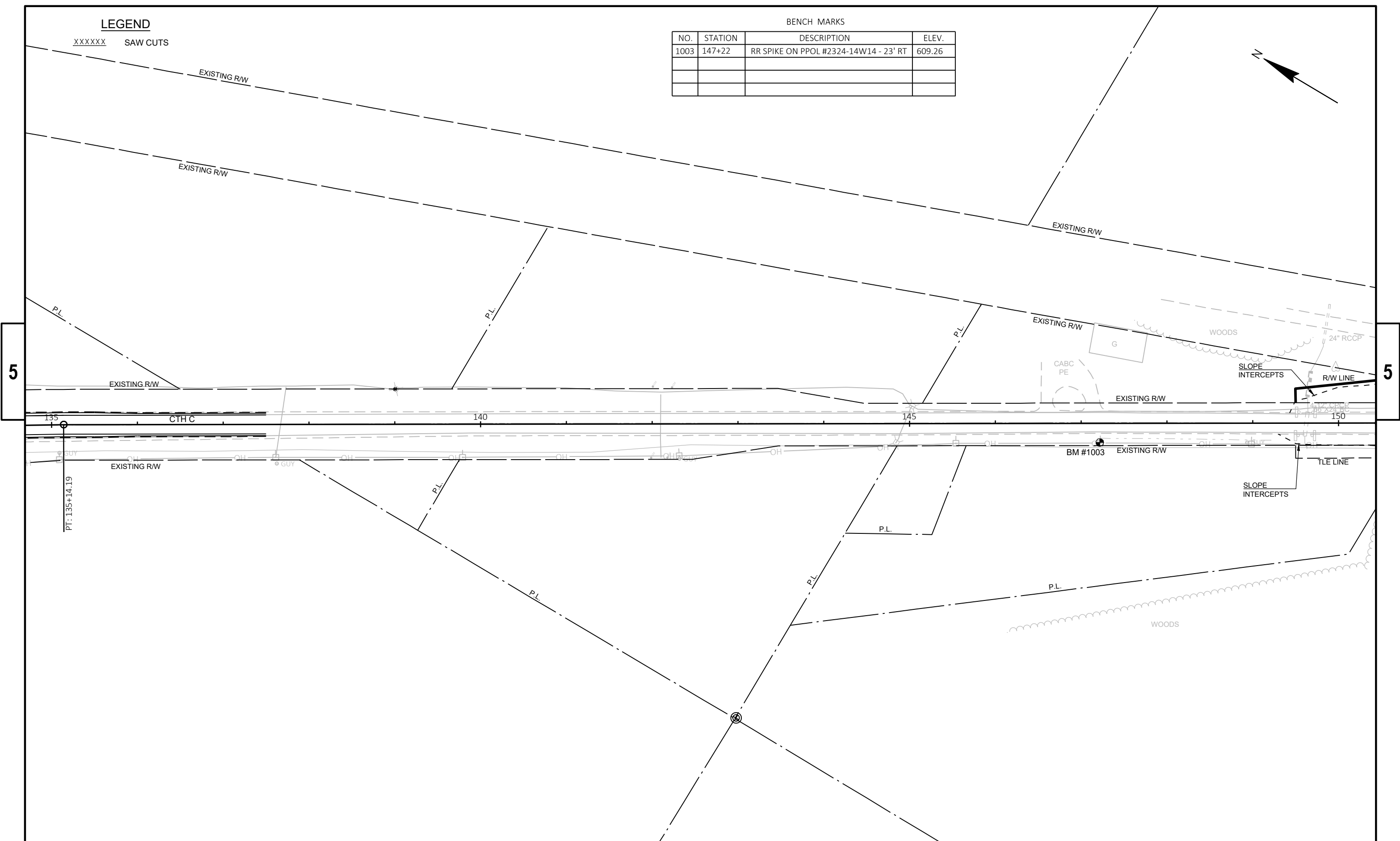
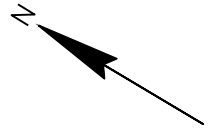

5

5

PROJECT NO: 4390-07-71

HWY: CTH C

COUNTY: KEWAUNEE

PLAN

SHEET

E

**LEGEND**

XXXXXX SAW CUTS

**BENCH MARKS**

NO.	STATION	DESCRIPTION	ELEV.
1004	158+42	RR SPIKE ON PPOL #2324-14W09 - 17' RT	615.93

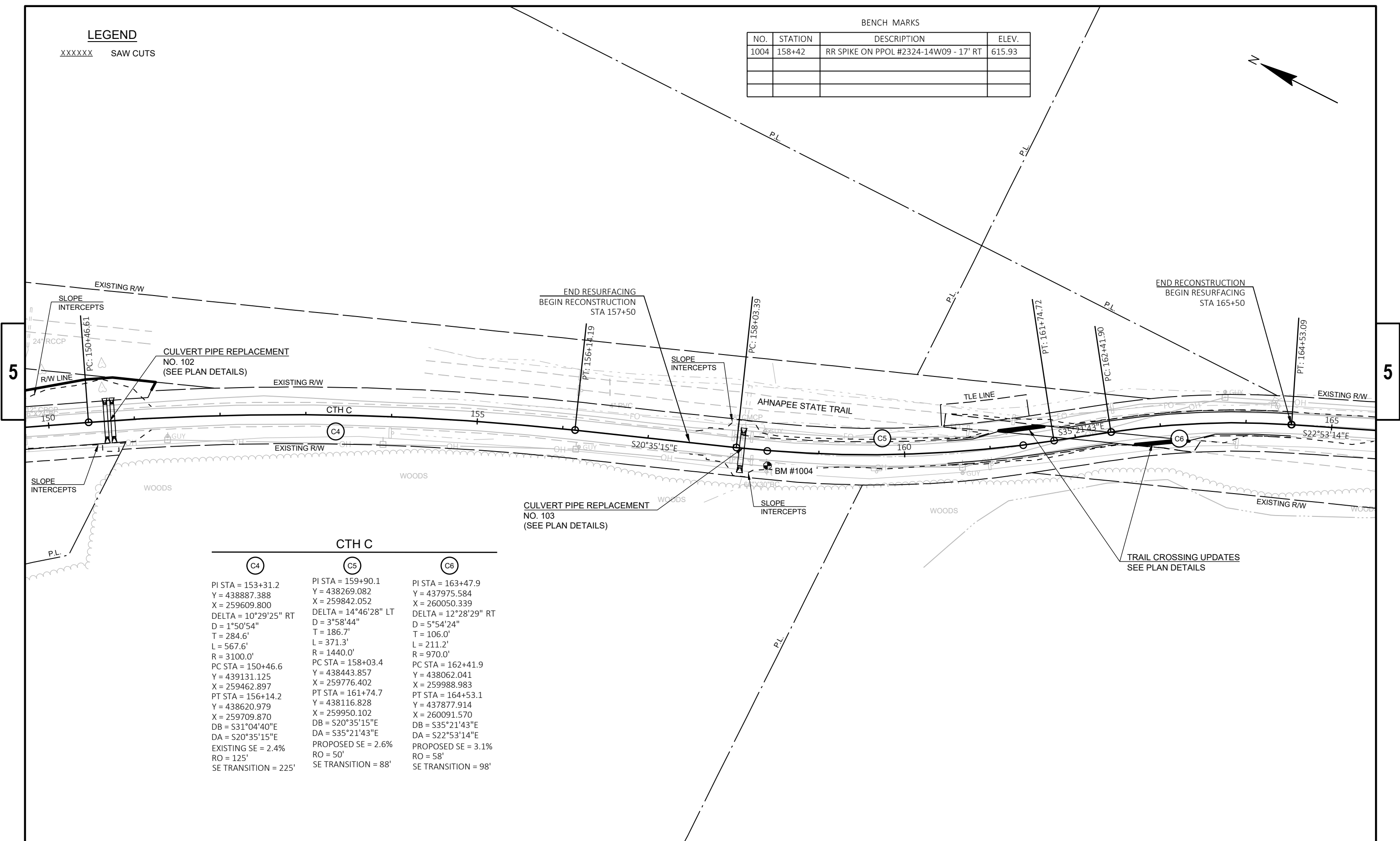
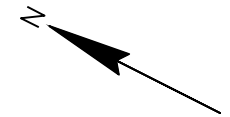

**CTH C**

(C4)	(C5)	(C6)
PI STA = 153+31.2	PI STA = 159+90.1	PI STA = 163+47.9
Y = 438887.388	Y = 438269.082	Y = 437975.584
X = 259609.800	X = 259842.052	X = 260050.339
DELTA = 10°29'25" RT	DELTA = 14°46'28" LT	DELTA = 12°28'29" RT
D = 1°50'54"	D = 3°58'44"	D = 5°54'24"
T = 284.6'	T = 186.7'	T = 106.0'
L = 567.6'	L = 371.3'	L = 211.2'
R = 3100.0'	R = 1440.0'	R = 970.0'
PC STA = 150+46.6	PC STA = 158+03.4	PC STA = 162+41.9
Y = 439131.125	Y = 438443.857	Y = 438062.041
X = 259462.897	X = 259776.402	X = 259988.983
PT STA = 156+14.2	PT STA = 161+74.7	PT STA = 164+53.1
Y = 438620.979	Y = 438116.828	Y = 437877.914
X = 259709.870	X = 259950.102	X = 260091.570
DB = S31°04'40"E	DB = S20°35'15"E	DB = S35°21'43"E
DA = S20°35'15"E	DA = S35°21'43"E	DA = S22°53'14"E
EXISTING SE = 2.4%	PROPOSED SE = 2.6%	PROPOSED SE = 3.1%
RO = 125'	RO = 50'	RO = 58'
SE TRANSITION = 225'	SE TRANSITION = 88'	SE TRANSITION = 98'

PROJECT NO: 4390-07-71

HWY: CTH C

COUNTY: KEWAUNEE

PLAN

SHEET

E

**LEGEND**

XXXXXX SAW CUTS

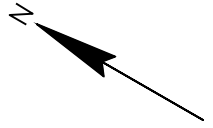

EP: 324+85.77  
Y = 437610.562  
X = 260731.034

N70°11'36"E  
GRANDVIEW LN.  
324

PI: 169+18.76  
Y = 437445.943  
X = 260273.953

BUTT JOINT  
REQ'D.

STA. 169+22.40 CTH C =  
STA. 320+00.00 GRANDVIEW LN  
Y = 437445.962  
X = 260274.005

MATCH EXISTING  
RADIUS (TYP)

PC: 171+13.56

PT: 174+56.81

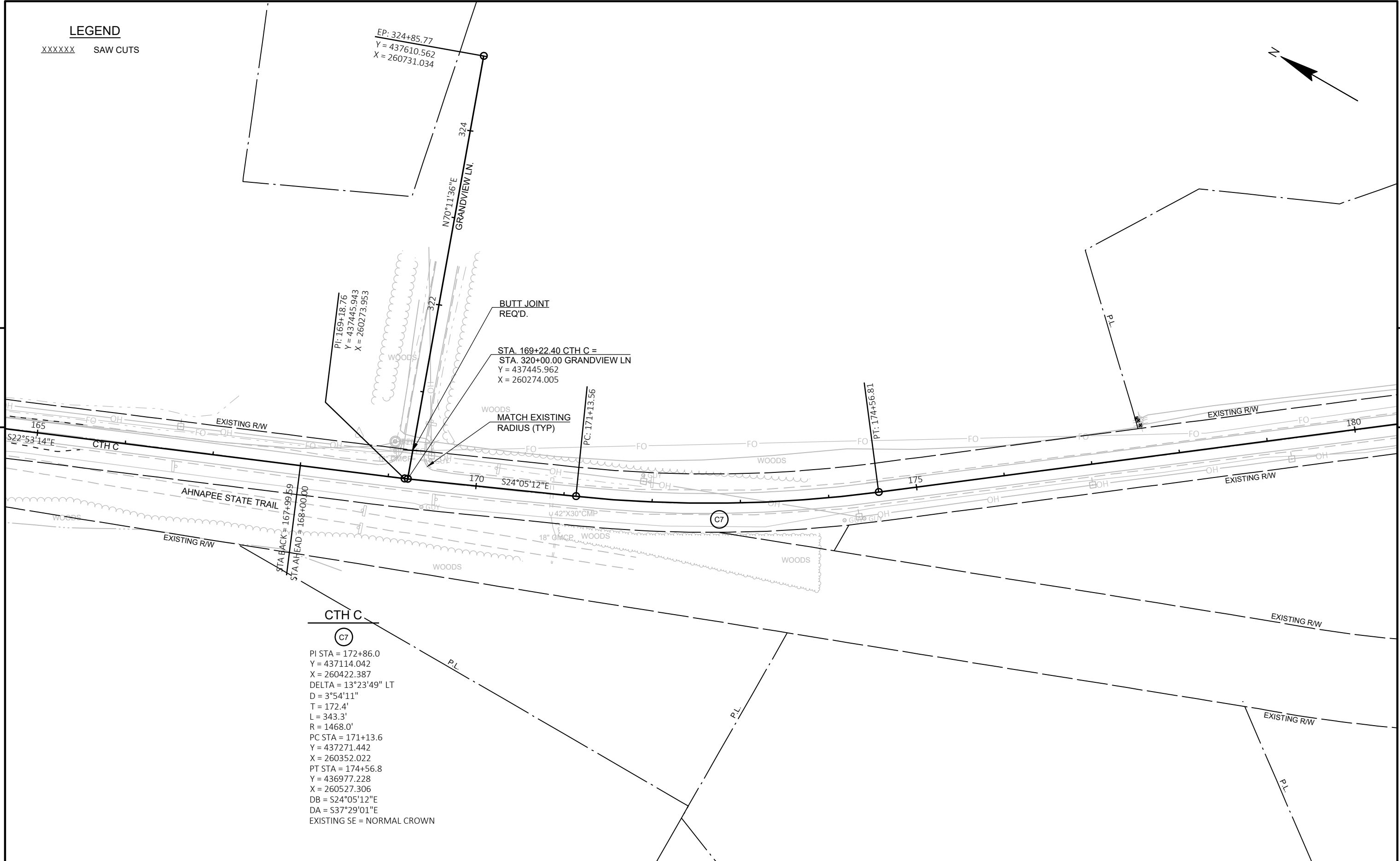

**CTH C**

(C7)

PI STA = 172+86.0  
Y = 437114.042  
X = 260422.387  
DELTA = 13°23'49" LT  
D = 3°54'11"  
T = 172.4'  
L = 343.3'  
R = 1468.0'  
PC STA = 171+13.6  
Y = 437271.442  
X = 260352.022  
PT STA = 174+56.8  
Y = 436977.228  
X = 260527.306  
DB = S24°05'12"E  
DA = S37°29'01"E  
EXISTING SE = NORMAL CROWN

PROJECT NO: 4390-07-71

HWY: CTH C

COUNTY: KEWAUNEE

PLAN

SHEET

**E**



**LEGEND**

XXXXXX SAW CUTS

BENCH MARKS			
NO.	STATION	DESCRIPTION	ELEV.
1005	193+71	SW CORNER BOTTOM STEP - 69' LT	611.72

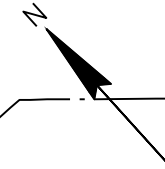

5

5

**CTH C**

(C9)

PI STA = 192+29.0  
 Y = 435570.987  
 X = 261605.718  
 DELTA = 58°16'52" LT  
 D = 15°26'37"  
 T = 206.8'  
 L = 377.4'  
 R = 371.0'  
 PC STA = 190+22.1  
 Y = 435735.121  
 X = 261479.849  
 PT STA = 193+99.5  
 Y = 435591.764  
 X = 261811.512  
 DB = S37°29'01"E  
 DA = N84°14'06"E  
 PROPOSED SE = 4.0%  
 RO = 77'  
 SE TRANSITION = 116'

**CTH F**

(C10)

PI STA = 328+97.6  
 Y = 435478.011  
 X = 261799.856  
 DELTA = 45°25'45" LT  
 D = 22°02'13"  
 T = 108.8'  
 L = 206.2'  
 R = 260.0'  
 PC STA = 327+88.8  
 Y = 435408.123  
 X = 261716.420  
 PT STA = 329+95.0  
 Y = 435586.495  
 X = 261808.623  
 DB = N50°02'59"E  
 DA = N04°37'13"E  
 PROPOSED SE = N/A

END RESURFACING  
 BEGIN RECONSTRUCTION  
 STA 188+25

STA. 193+97.00 CTH C =  
 STA. 330+00.00 CTH F  
 Y = 435591.523  
 X = 261809.030

CP #902  
 STA. 327+92.85-41.27' LT  
 Y=435439.441  
 X=261689.349  
 RR SPIKE

CONSTRUCTION LIMITS  
 STA. 327+71.8

BP: 326+45.42  
 Y = 435316.051  
 X = 261606.500

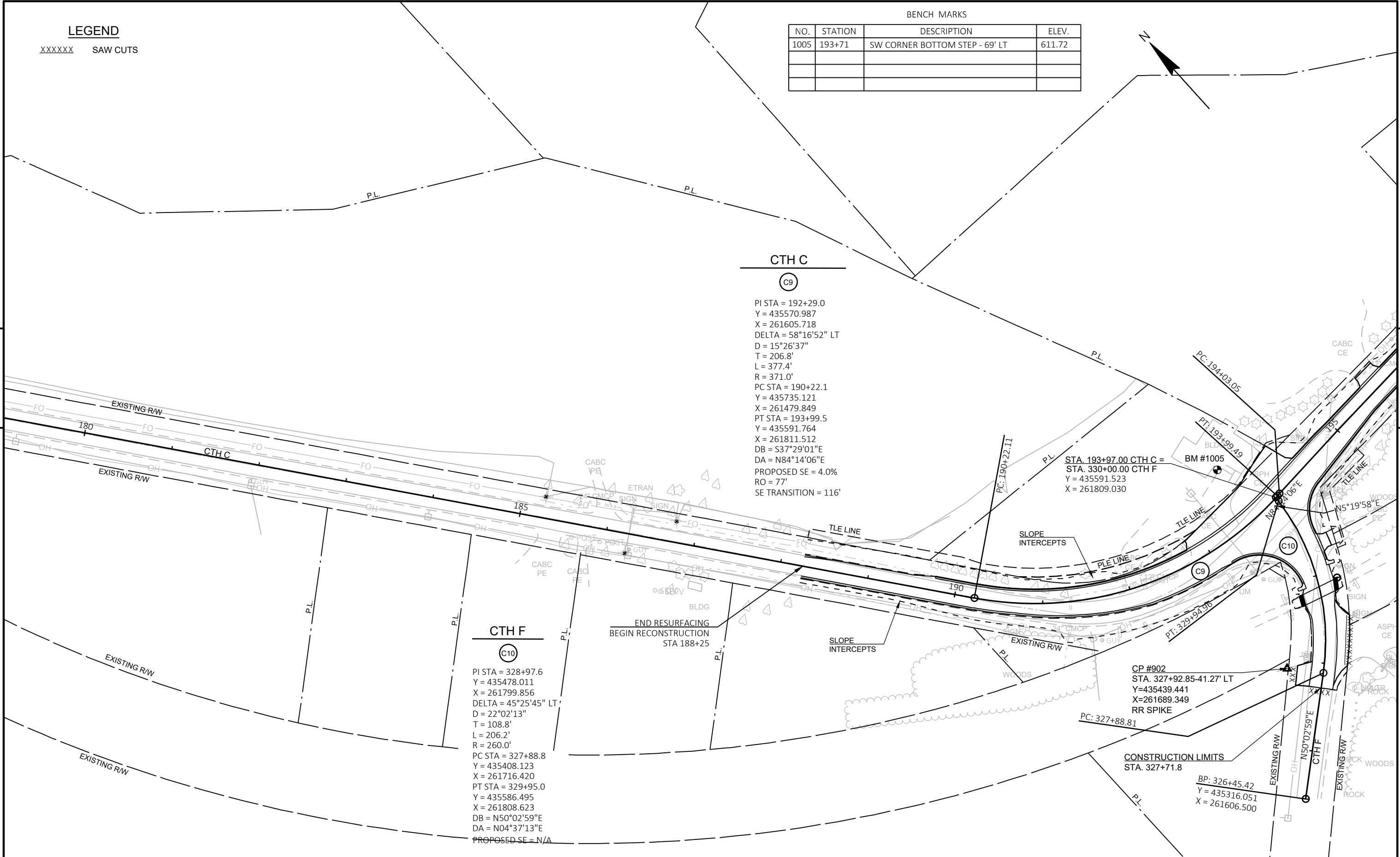

**LEGEND**

XXXXXX SAW CUTS

BENCH MARKS			
NO.	STATION	DESCRIPTION	ELEV.
1006	209+49	CONC. LIP SW CORNER OF BRIDGE - 20' RT	597.67

**HILLCREST LN**

(C12)

PI STA = 350+50.8  
 Y = 435669.142  
 X = 262739.138  
 DELTA = 35°50'32" LT  
 D = 38°11'50"  
 T = 48.5'  
 L = 93.8'  
 R = 150.0'  
 PC STA = 350+02.3  
 Y = 435623.059  
 X = 262754.290  
 PT STA = 350+96.1  
 Y = 435697.626  
 X = 262699.871  
 DB = N18°12'03"W  
 DA = N54°02'35"W



5

5

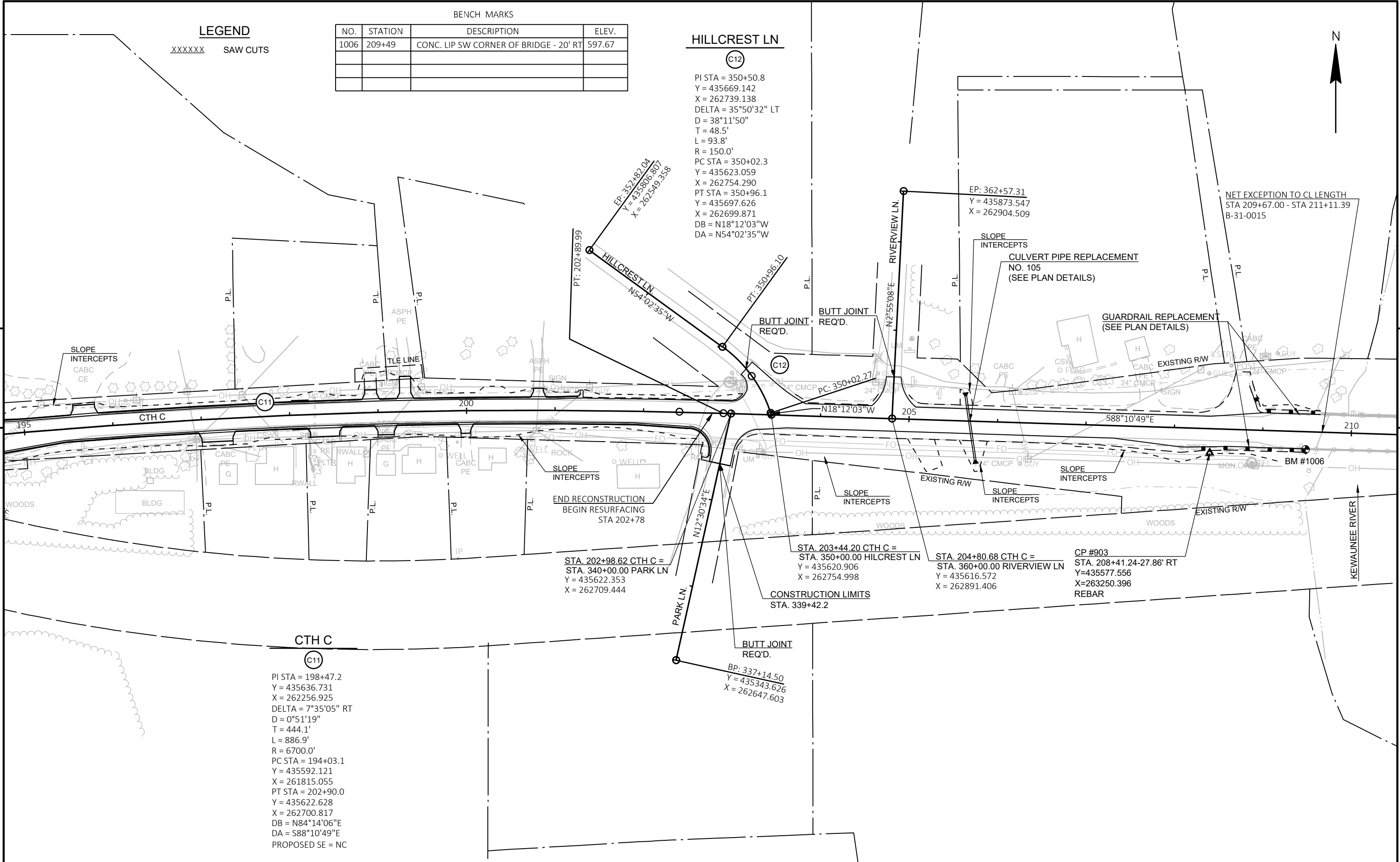

**CTH C**

(C11)

PI STA = 198+47.2  
 Y = 435636.731  
 X = 262256.925  
 DELTA = 7°35'05" RT  
 D = 0°51'19"  
 T = 444.1'  
 L = 886.9'  
 R = 6700.0'  
 PC STA = 194+03.1  
 Y = 435592.121  
 X = 261815.055  
 PT STA = 202+90.0  
 Y = 435622.628  
 X = 262700.817  
 DB = N84°14'06"E  
 DA = S88°10'49"E  
 PROPOSED SE = NC

STA. 202+98.62 CTH C =  
 STA. 340+00.00 PARK LN  
 Y = 435622.353  
 X = 262709.444

STA. 203+44.20 CTH C =  
 STA. 350+00.00 HILLCREST LN  
 Y = 435620.906  
 X = 262754.998

STA. 204+80.68 CTH C =  
 STA. 360+00.00 RIVERVIEW LN  
 Y = 435616.572  
 X = 262891.406

CP #903  
 STA. 208+41.24-27.86' RT  
 Y=435577.556  
 X=263250.396  
 REBAR

BP: 337+14.50  
 Y = 435343.626  
 X = 262647.603

**LEGEND**

XXXXXX SAW CUTS



CP #904  
 STA. 216+24.03-29.88' LT  
 Y=435645.120  
 X=264029.309  
 REBAR

GUARDRAIL REPLACEMENT  
 (SEE PLAN DETAILS)

NET EXCEPTION TO CL LENGTH  
 STA 209+67.00 - STA 211+11.39  
 B-31-0015

**CTH C**

(C13)

PI STA = 213+84.1  
 Y = 435587.881  
 X = 263794.392  
 DELTA = 8°43'15" LT  
 D = 2°30'00"  
 T = 174.8'  
 L = 348.8'  
 R = 2291.8'  
 PC STA = 212+09.4  
 Y = 435593.431  
 X = 263619.726  
 PT STA = 215+58.2  
 Y = 435608.879  
 X = 263967.880  
 DB = S88°10'49"E  
 DA = N83°05'56"E  
 PROPOSED SE = 2.7%  
 RO = 60'  
 SE TRANSITION = 104'

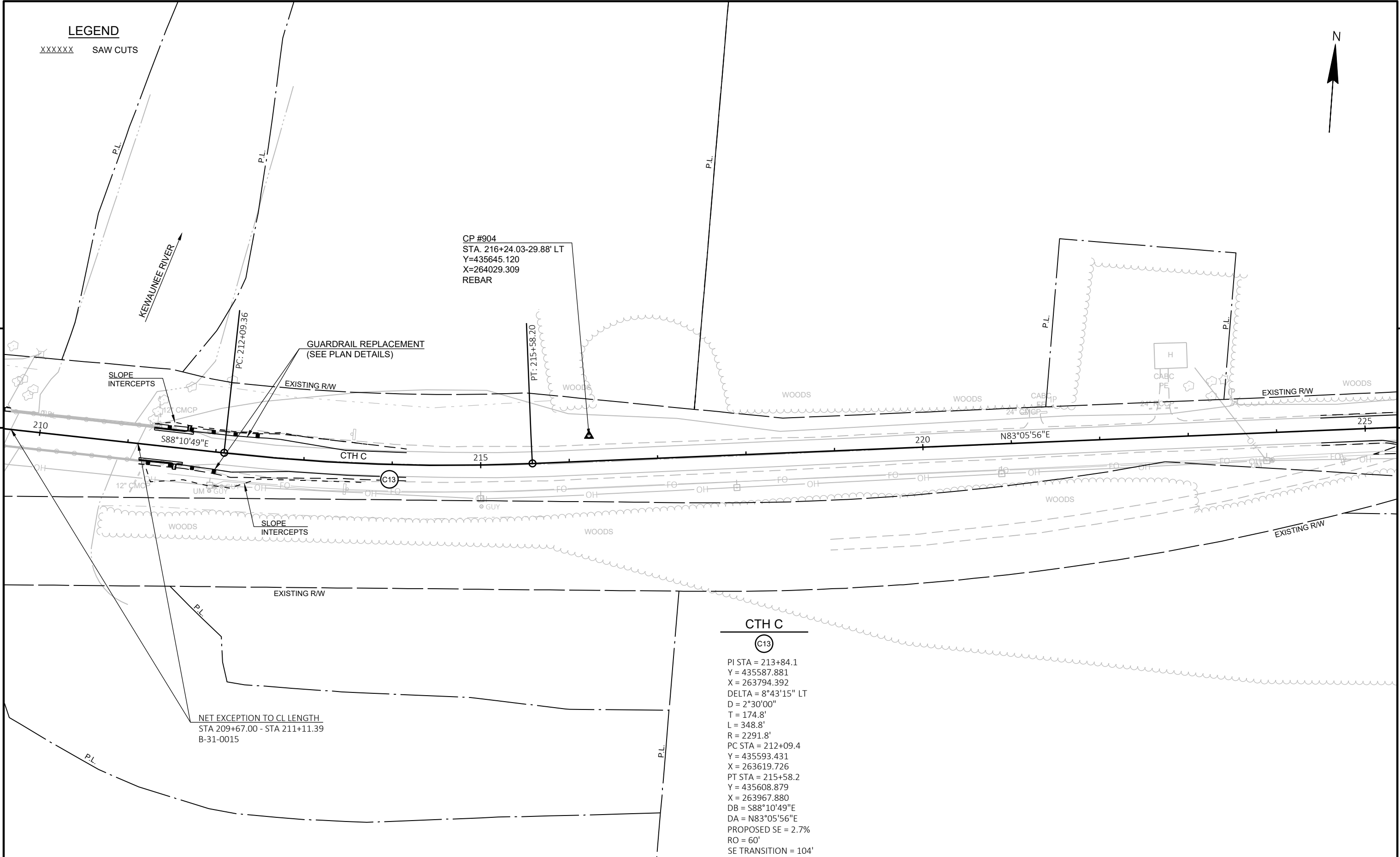

**LEGEND**

XXXXXX SAW CUTS

**BENCH MARKS**

NO.	STATION	DESCRIPTION	ELEV.
1007	235+02	RR SPIKE ON PPOL #2324-13L3 - 42' RT	599.61
1009	237+96	NAIL ON PPOL #2324-13L2 - 27' RT	621.13

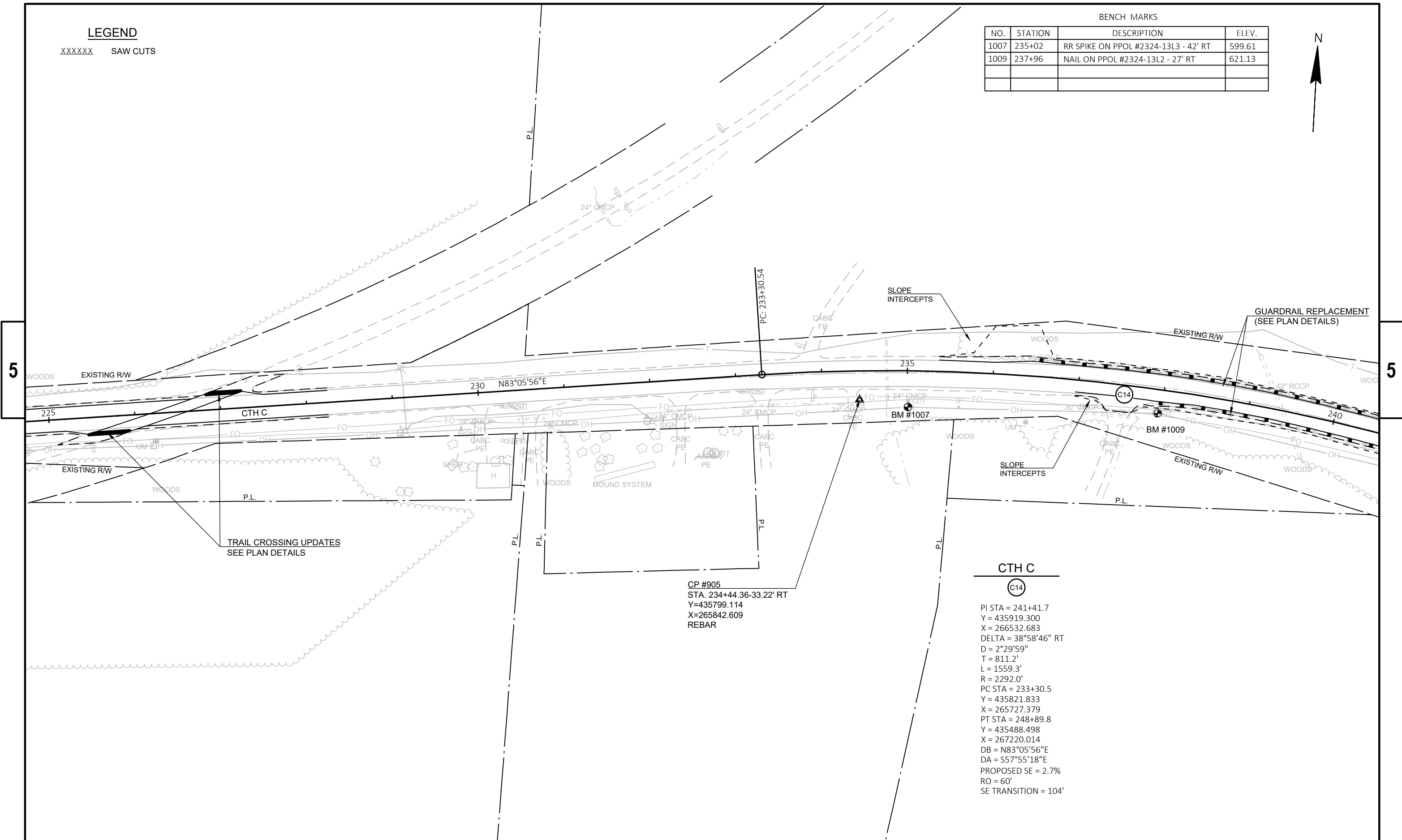

CP #905  
 STA. 234+44.36-33.22' RT  
 Y=435799.114  
 X=265842.609  
 REBAR

**CTH C**

(C14)  
 PI STA = 241+41.7  
 Y = 435919.300  
 X = 266532.683  
 DELTA = 38°58'46" RT  
 D = 2°29'59"  
 T = 811.2'  
 L = 1559.3'  
 R = 2292.0'  
 PC STA = 233+30.5  
 Y = 435821.833  
 X = 265727.379  
 PT STA = 248+89.8  
 Y = 435488.498  
 X = 267220.014  
 DB = N83°05'56"E  
 DA = S57°55'18"E  
 PROPOSED SE = 2.7%  
 RO = 60'  
 SE TRANSITION = 104'

PROJECT NO: 4390-07-71

HWY: CTH C

COUNTY: KEWAUNEE

PLAN

SHEET

E

**LEGEND**

XXXXXX SAW CUTS

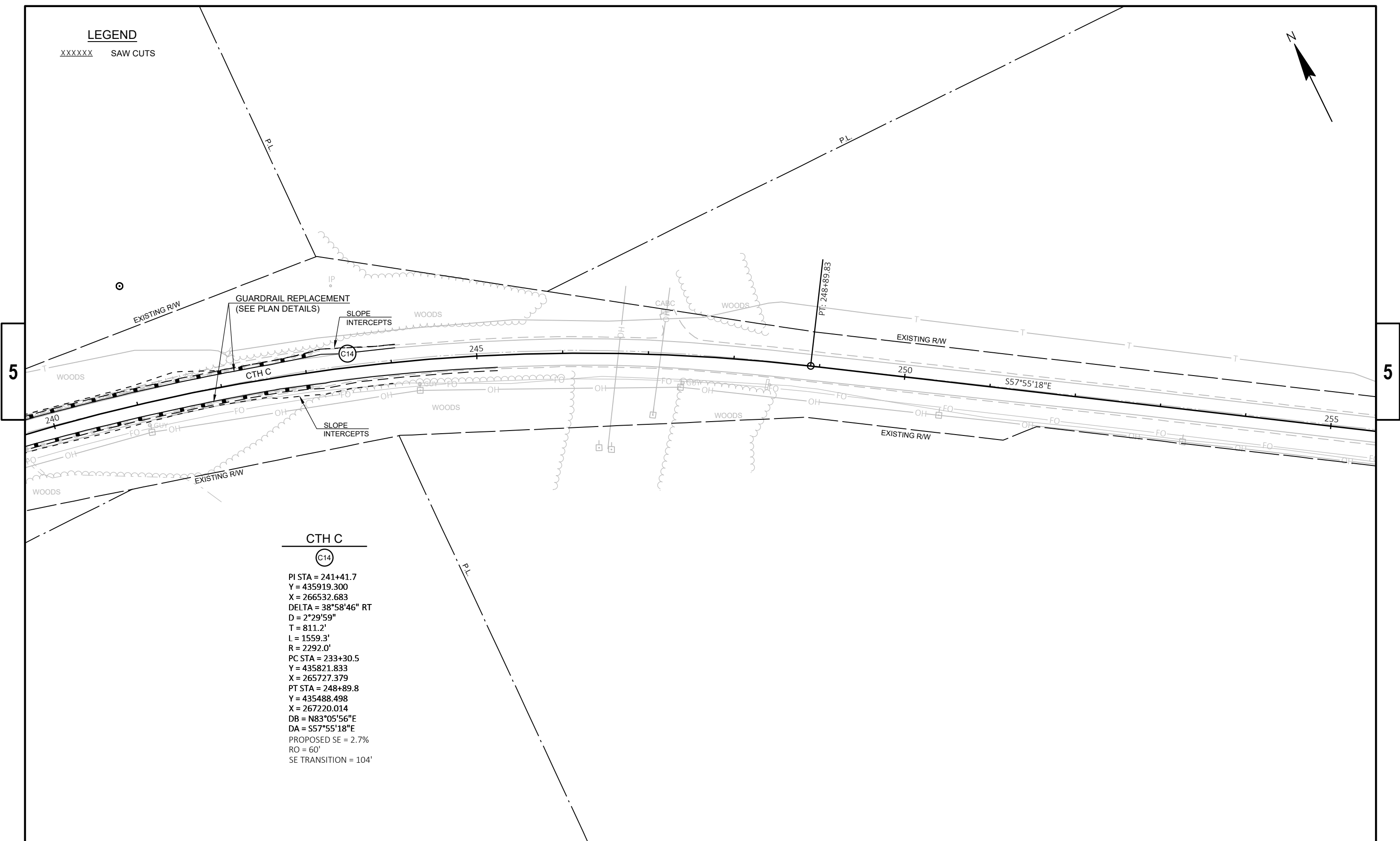
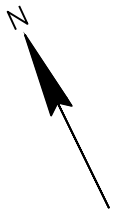

**CTH C**

(C14)

PI STA = 241+41.7  
 Y = 435919.300  
 X = 266532.683  
 DELTA = 38°58'46" RT  
 D = 2°29'59"  
 T = 811.2'  
 L = 1559.3'  
 R = 2292.0'  
 PC STA = 233+30.5  
 Y = 435821.833  
 X = 265727.379  
 PT STA = 248+89.8  
 Y = 435488.498  
 X = 267220.014  
 DB = N83°05'56"E  
 DA = S57°55'18"E  
 PROPOSED SE = 2.7%  
 RO = 60'  
 SE TRANSITION = 104'

PROJECT NO: 4390-07-71	HWY: CTH C	COUNTY: KEWAUNEE	PLAN	SHEET	<b>E</b>
------------------------	------------	------------------	------	-------	----------

**LEGEND**

XXXXXX SAW CUTS

**BENCH MARKS**

NO.	STATION	DESCRIPTION	ELEV.
1008	269+41	SW FLANGE BOLT ON HYD. - 26' RT	710.68

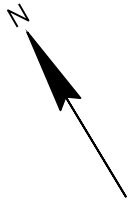

5

5

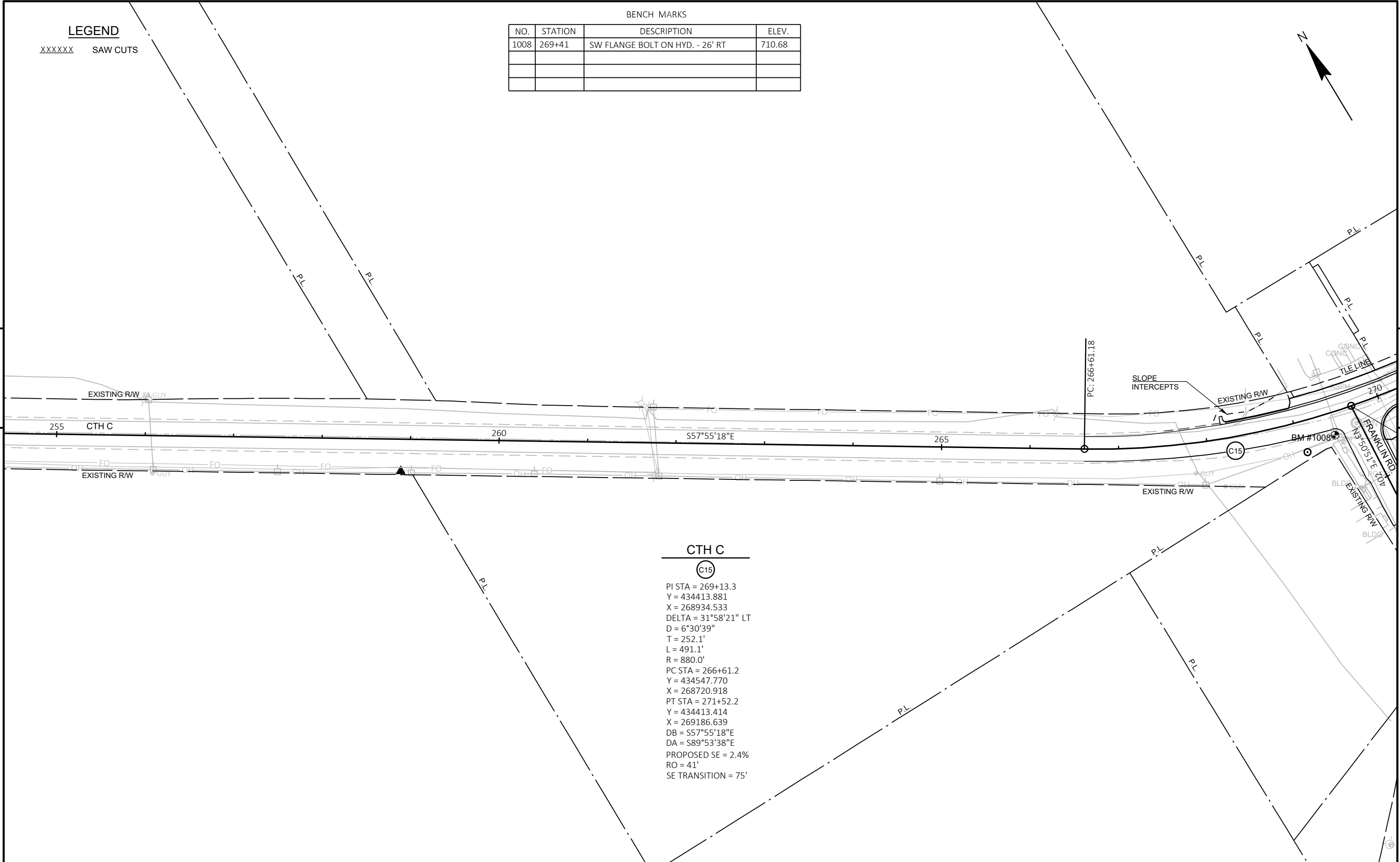

**CTH C**

(C15)

PI STA = 269+13.3  
 Y = 434413.881  
 X = 268934.533  
 DELTA = 31°58'21" LT  
 D = 6°30'39"  
 T = 252.1'  
 L = 491.1'  
 R = 880.0'  
 PC STA = 266+61.2  
 Y = 434547.770  
 X = 268720.918  
 PT STA = 271+52.2  
 Y = 434413.414  
 X = 269186.639  
 DB = S57°55'18"E  
 DA = S89°53'38"E  
 PROPOSED SE = 2.4%  
 RO = 41'  
 SE TRANSITION = 75'

PROJECT NO: 4390-07-71	HWY: CTH C	COUNTY: KEWAUNEE	PLAN	SHEET	<b>E</b>
------------------------	------------	------------------	------	-------	----------

**LEGEND**

XXXXXX SAW CUTS

**BENCH MARKS**

NO.	STATION	DESCRIPTION	ELEV.
1008	269+41	SW FLANGE BOLT ON HYD. - 26' RT	710.68



**CTH C**

(C16)  
 PI STA = 269+13.3  
 Y = 434413.881  
 X = 268934.533  
 DELTA = 31°58'21" LT  
 D = 6°30'39"  
 T = 252.1'  
 L = 491.1'  
 R = 880.0'  
 PC STA = 266+61.2  
 Y = 434547.770  
 X = 268720.918  
 PT STA = 271+52.2  
 Y = 434413.414  
 X = 269186.639  
 DB = S57°55'18"E  
 DA = S89°53'38"E  
 PROPOSED SE = 2.4%  
 RO = 41'  
 SE TRANSITION = 75'

**FRANKLIN RD**

(C17)  
 PI STA = 400+80.5  
 Y = 434223.013  
 X = 268989.673  
 DELTA = 22°07'54" RT  
 D = 16°22'13"  
 T = 68.5'  
 L = 135.2'  
 R = 350.0'  
 PC STA = 400+12.1  
 Y = 434158.019  
 X = 269011.148  
 PT STA = 401+47.2  
 Y = 434291.309  
 X = 268994.266  
 DB = N18°17'02"W  
 DA = N03°50'51"E

**END PROJECT  
 STA. 273+00.3**

STA. 269+68.02 CTH C =  
 STA. 402+89.22 FRANKLIN ST  
 Y = 434432.966  
 X = 269003.793  
 PT: 401+47.25

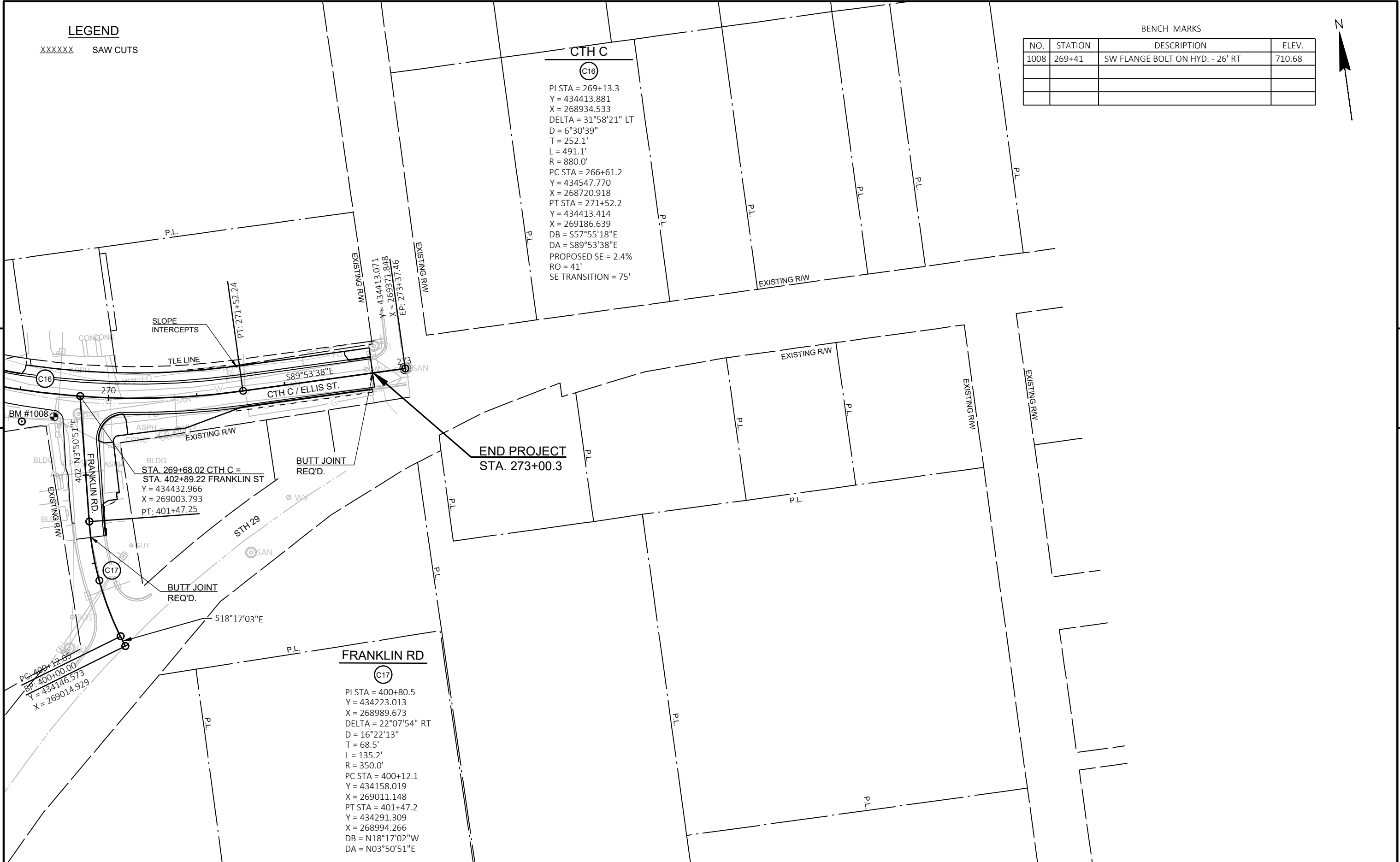

PROJECT NO: 4390-07-71

HWY: CTH C

COUNTY: KEWAUNEE

PLAN

SHEET

**E**

## Standard Detail Drawing List

08A05-20B	INLET COVERS TYPE B, B-A, C, MS, MS-A, & WM
08A05-20C	INLET COVERS TYPE F, HM, HM-S, S, T, V, HM-GJ, & HM-GJ-S
08A05-20D	INLET COVER TYPE BW, MANHOLE COVERS, TYPE K, J, J-S, L & M
08A09-02	CATCH BASINS 2X3-FT AND 2.5X3-FT
08B09-03	MANHOLES 3-FT, 4-FT, 5-FT, 6-FT, 7-FT, 8-FT, 9-FT, 10-FT DIAMETER
08C08-02	INLETS MEDIAN 1 AND 2 GRATE
08D01-23A	CONCRETE CURB & GUTTER
08D01-23B	CONCRETE CURB, TIES AND CURB AND GUTTER APPLICATIONS
08D02-08A	CONCRETE SURFACE DRAINS FLUME TYPE AT STRUCTURES
08D02-08B	CONCRETE SURFACE DRAINS FLUME TYPE AT STRUCTURES
08D02-08C	CONCRETE SURFACE DRAINS FLUME TYPE AT STRUCTURES
08D04-07	CONCRETE SURFACE DRAINS & ASPHALTIC FLUMES
08D05-21G	CURB RAMPS RECTANGULAR AND RADIAL DETECTABLE WARNING PLATES
08E09-06	SILT FENCE
08E10-02	INLET PROTECTION TYPE A, B, C AND D
08E15-01	CULVERT PIPE CHECK
08F01-11	APRON ENDWALLS FOR CULVERT PIPE
08F02-01	APRON ENDWALLS FOR PIPE ARCH AND ELLIPTICAL PIPE
08F04-08	JOINT TIES FOR CONCRETE PIPE AND CONCRETE COLLAR DETAIL
09A01-14A	AT-GRADE SIDE ROAD INTERSECTION, TYPES "B1", "B2", "C" AND D AND TEE INTERSECTION BYPASS LANE
13C19-03	HMA LONGITUDINAL JOINTS
14B29-01	SAFETY EDGE
14B42-07A	MIDWEST GUARDRAIL SYSTEM (MGS) GUARDRAIL
14B42-07B	MIDWEST GUARDRAIL SYSTEM (MGS) GUARDRAIL
14B42-07C	MIDWEST GUARDRAIL SYSTEM (MGS) GUARDRAIL
14B42-07D	MIDWEST GUARDRAIL SYSTEM (MGS) GUARDRAIL
14B44-04A	MIDWEST GUARDRAIL SYSTEM ENERGY ABSORBING TERMINAL (MGS)
14B44-04B	MIDWEST GUARDRAIL SYSTEM ENERGY ABSORBING TERMINAL (MGS)
14B44-04C	MIDWEST GUARDRAIL SYSTEM ENERGY ABSORBING TERMINAL (MGS)
14B45-05A	MIDWEST GUARDRAIL SYSTEM THRIE BEAM TRANSITION (MGS)
14B45-05B	MIDWEST GUARDRAIL SYSTEM THRIE BEAM TRANSITION (MGS)
14B45-05C	MIDWEST GUARDRAIL SYSTEM THRIE BEAM TRANSITION (MGS)
14B45-05D	MIDWEST GUARDRAIL SYSTEM THRIE BEAM TRANSITION (MGS)
14B45-05G	MIDWEST GUARDRAIL SYSTEM THRIE BEAM TRANSITION (MGS)
14B53-02A	SHORT RADIUS BEAM GUARD (MGS) SHORT RADIUS TERMINAL (MGS)
14B53-02B	SHORT RADIUS BEAM GUARD (MGS) SHORT RADIUS TERMINAL (MGS)
14B53-02C	SHORT RADIUS BEAM GUARD (MGS) SHORT RADIUS TERMINAL (MGS)
14B53-02D	SHORT RADIUS BEAM GUARD (MGS) SHORT RADIUS TERMINAL (MGS)
14B53-02E	SHORT RADIUS BEAM GUARD (MGS) SHORT RADIUS TERMINAL (MGS)
14B53-02F	SHORT RADIUS BEAM GUARD (MGS) SHORT RADIUS TERMINAL (MGS)
14B53-02G	SHORT RADIUS BEAM GUARD (MGS) SHORT RADIUS TERMINAL (MGS)
14B53-02H	SHORT RADIUS BEAM GUARD (MGS) SHORT RADIUS TERMINAL (MGS)
14B53-02I	SHORT RADIUS BEAM GUARD (MGS) SHORT RADIUS TERMINAL (MGS)
15C02-09A	BARRICADES AND SIGNS FOR MAINLINE CLOSURES
15C02-09B	BARRICADES AND SIGNS FOR VARIOUS CLOSURES
15C02-09C	DETOUR SIGNING FOR MAINLINE CLOSURES
15C03-05	BARRICADES AND SIGNS FOR SIDEROAD CLOSURES
15C08-23A	PERMANENT LONGITUDINAL PAVEMENT MARKINGS
15C11-10B	CHANNELIZING DEVICES DRUMS, CONES, BARRICADES AND VERTICAL PANELS
15C35-06A	PAVEMENT MARKING (INTERSECTIONS)
15D28-04	TRAFFIC CONTROL, WORK ON SHOULDER OR PARKING LANE, UNDIVIDED ROADWAY
15D44-02	TRAFFIC CONTROL, SIGNING ON ROADWAYS WITH MILLED SURFACES
15D45-03	TRAFFIC CONTROL, SIGNING ON ROADWAYS WITH LOOSE GRAVEL



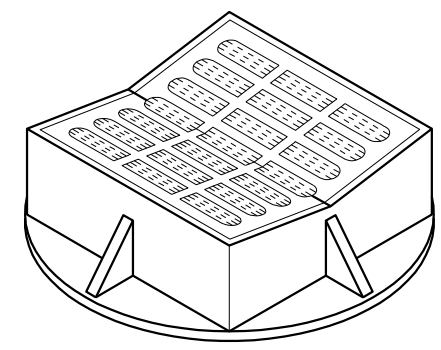
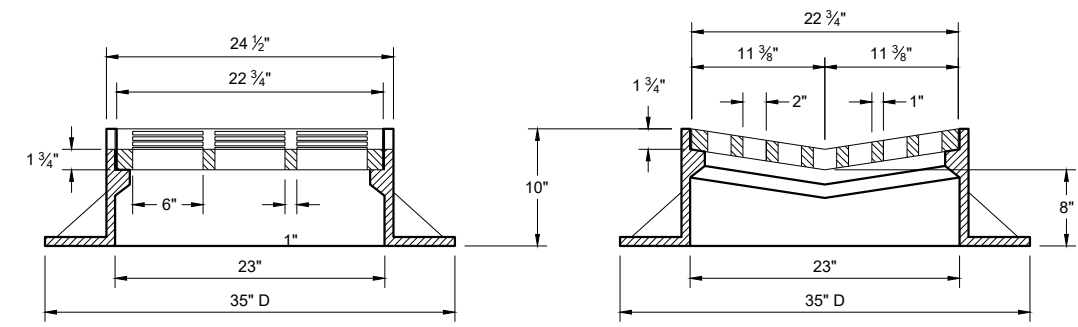

**TYPE "B"**

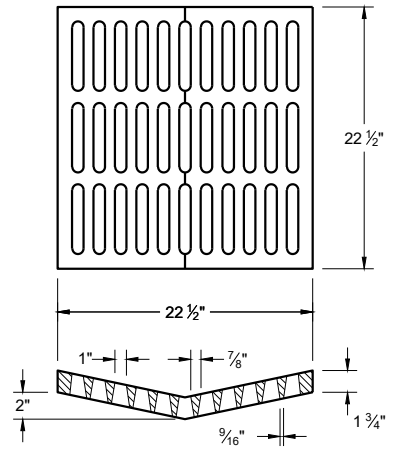
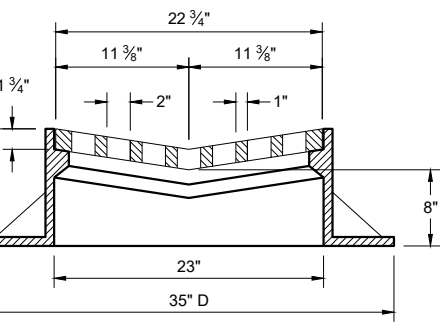

**ALTERNATIVE GRATE FOR TYPE "B" COVER**

USE WHERE PEDESTRIAN OR BICYCLE TRAFFIC IS POSSIBLE  
**NOTED AS TYPE B - A ON THE DRAINAGE TABLE**

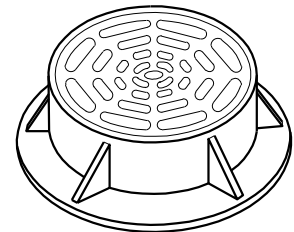
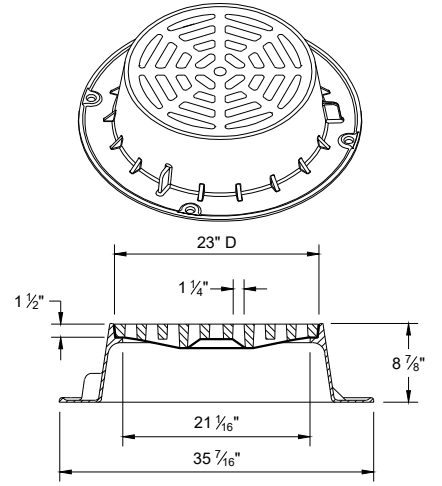

**TYPE "C"**

NOTE: EITHER CASTING IS ACCEPTABLE

**GENERAL NOTES**

DETAILS OF CONSTRUCTION, MATERIALS AND WORKMANSHIP NOT SHOWN ON THIS DRAWING SHALL CONFORM TO THE PERTINENT REQUIREMENTS OF THE STANDARD SPECIFICATIONS AND THE APPLICABLE SPECIAL PROVISIONS.

DETAIL DRAWINGS FOR PROPOSED ALTERNATE DESIGNS FOR CATCH BASIN, MANHOLE AND INLET COVERS SHALL BE SUBMITTED TO THE ENGINEER FOR APPROVAL PROVIDING THAT SUCH ALTERNATE DESIGNS MAKE PROVISION FOR EQUIVALENT CAPACITY AND STRENGTH.

ROUND FRAMES AND COVERS SHALL HAVE CONTINUOUSLY MACHINED BEARING SURFACES TO PREVENT ROCKING AND RATTLING.

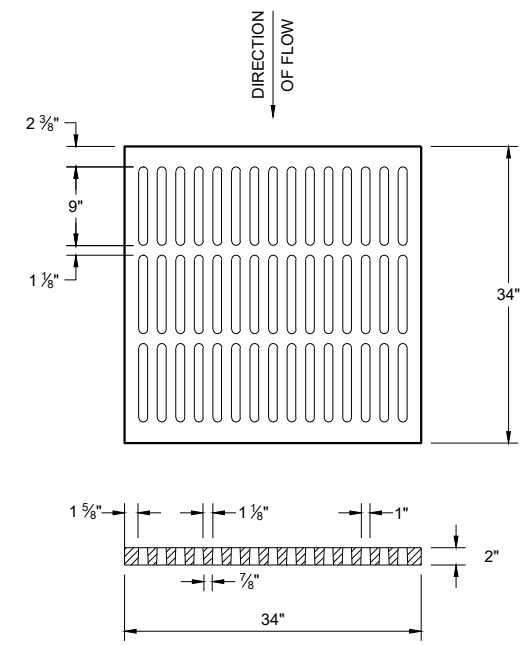

**ALTERNATIVE TYPE "MS"**

USE WHERE PEDESTRIAN OR BICYCLE TRAFFIC IS PERMITTED  
**NOTED AS TYPE MS-A ON THE DRAINAGE TABLE**

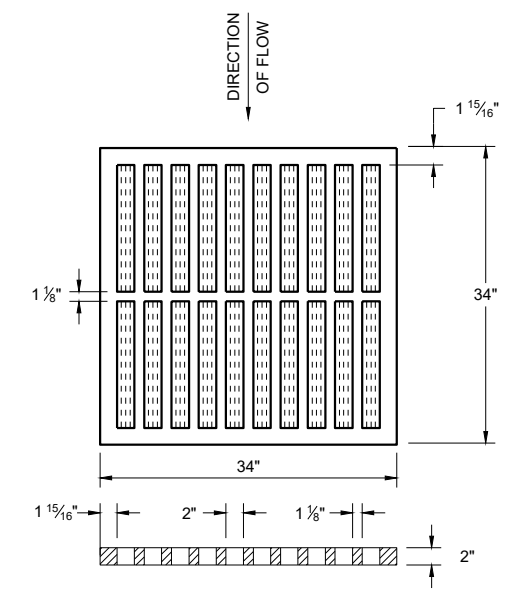

**TYPE "MS"**

USE ON FREEWAYS AND EXPRESSWAYS  
**NOTED AS TYPE MS ON THE DRAINAGE TABLE**

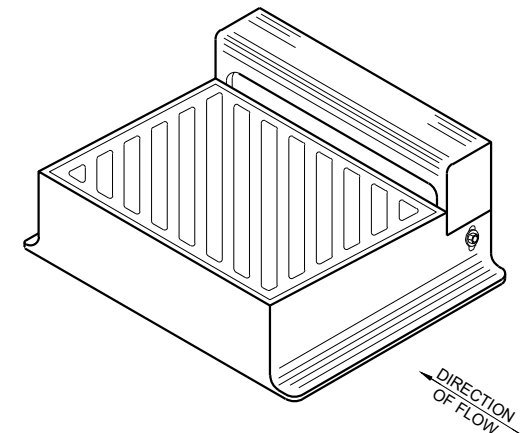

DIRECTION OF FLOW

DIAGONAL SLOTS SHALL BE ORIENTED TO THE DIRECTION OF FLOW AS ILLUSTRATED.  
 GRATES ARE MANUFACTURED TO BE REVERSIBLE.

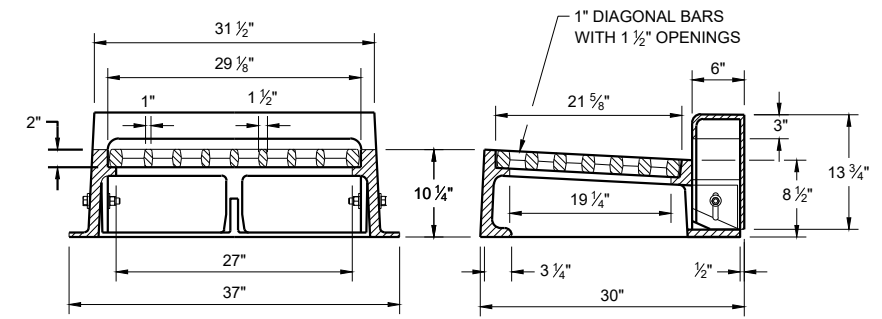

**TYPE "WM"**

NOTE: CURB BOX HEIGHT ADJUSTABLE 6" - 9"

6

6

SDD 08A05-20b

SDD 08A05-20b

**INLET COVERS  
 TYPES B, B-A, C,  
 MS, MS-A AND WM**

STATE OF WISCONSIN  
 DEPARTMENT OF TRANSPORTATION

APPROVED  
 July 2023 /S/ Rodney Taylor  
 DATE ROADWAY STANDARDS DEVELOPMENT  
 FHWA UNIT SUPERVISOR

**GENERAL NOTES**

DETAILS OF CONSTRUCTION, MATERIALS AND WORKMANSHIP NOT SHOWN ON THIS DRAWING SHALL CONFORM TO THE PERTINENT REQUIREMENTS OF THE STANDARD SPECIFICATIONS AND THE APPLICABLE SPECIAL PROVISIONS.

DETAIL DRAWINGS FOR PROPOSED ALTERNATE DESIGNS FOR INLET COVERS SHALL BE SUBMITTED TO THE ENGINEER FOR APPROVAL PROVIDING THAT SUCH ALTERNATE DESIGNS MAKE PROVISION FOR EQUIVALENT CAPACITY AND STRENGTH.

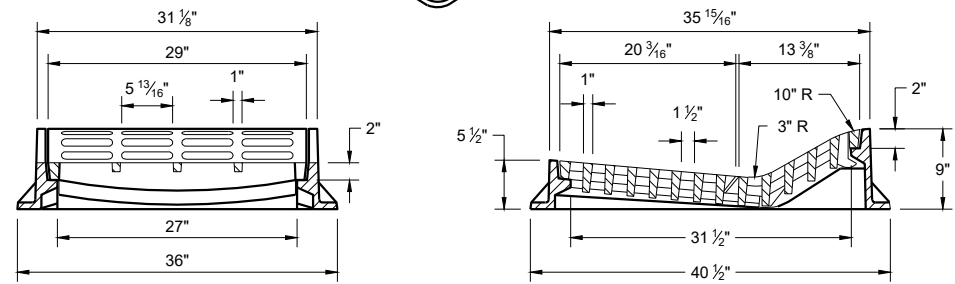
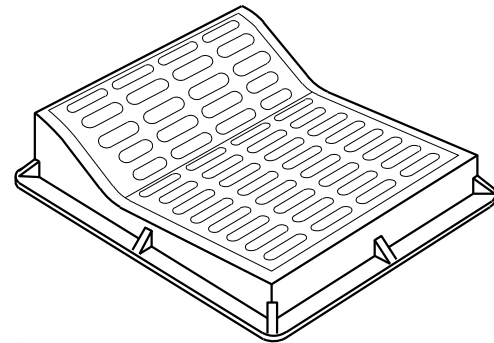

**TYPE "F"**

USE WITH TYPES "A" AND "D" CONCRETE CURB AND GUTTER, 36"

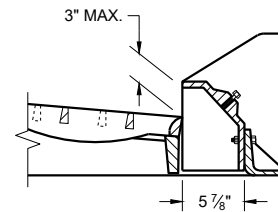

**ALTERNATIVE CURB BOX FOR TYPE "HM" COVER**

USE WITH TYPES "G" AND "J" CONCRETE CURB AND GUTTER, 30 INCH NOTED AS TYP "HM-GJ" ON DRAINAGE TABLE

NOTE: SPECIAL GRATE FOR THE TYPE "H" COVER MAY ALSO BE USED FOR THE TYPE "HM-GJ" COVER.

NOTED AS TYPE HM-GJ-S ON THE DRAINAGE TABLE.

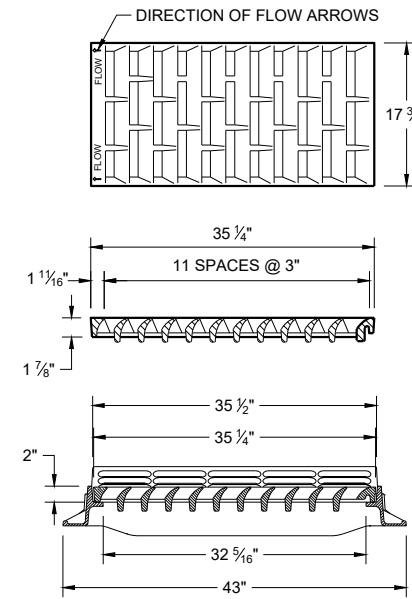

**TYPE "HM"**

USE WITH TYPES "A" AND "D" CONCRETE CURB AND GUTTER, 36"

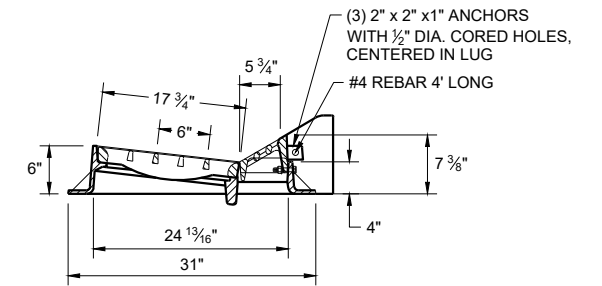
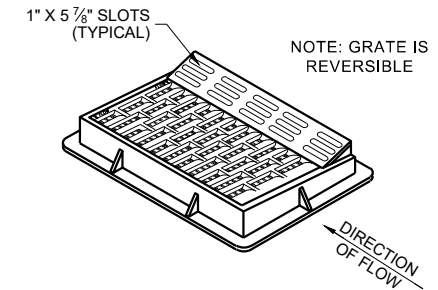

NOTE: SPECIAL GRATE FOR THE TYPE "H" COVER MAY ALSO BE USED FOR THE TYPE "HM-GJ" COVER.

NOTED AS TYPE HM-GJ-S ON THE DRAINAGE TABLE.

6

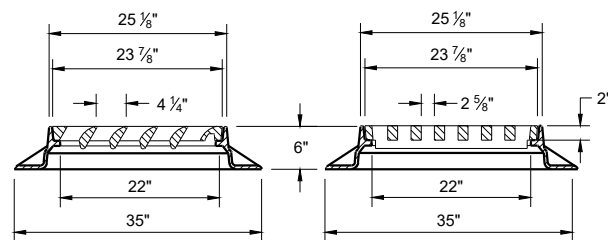
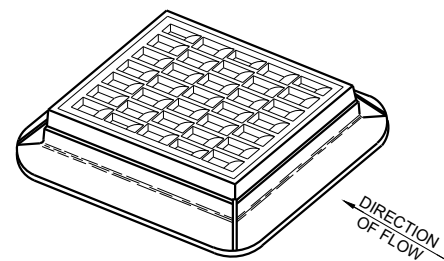

**TYPE "S"**

SDD 08A05-20C

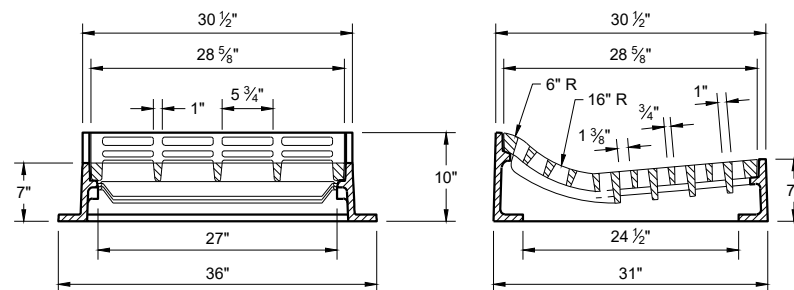
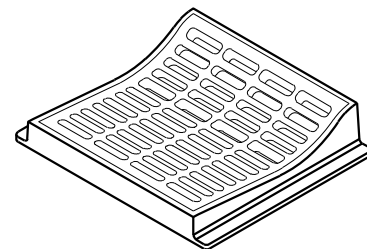

**TYPE "T"**

USE WITH TYPES "R" AND "T" CONCRETE CURB AND GUTTER, 36"

6

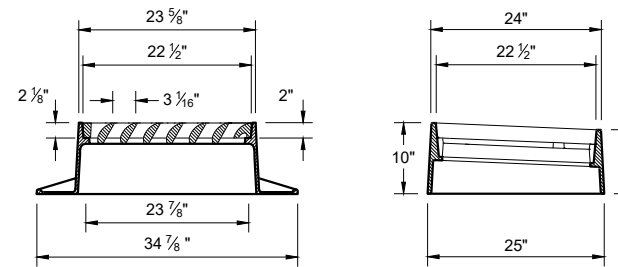
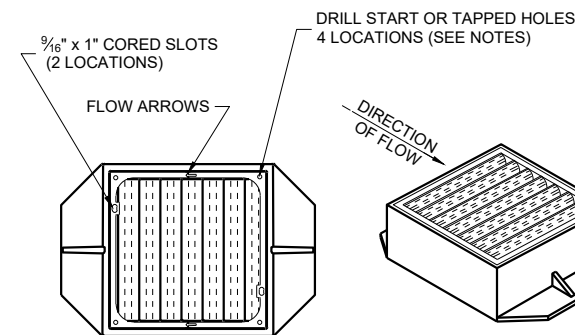

**TYPE "V"**

NOTES: ALL HARDWARE TO BE SUPPLIED BY CASTING MANUFACTURER ALL DRILLING AND TAPPING GRATES AND FRAMES BY CASTING MANUFACTURER

TYPE V  
FRAME - CAST GRAY IRON ASTM A48 CLASS 40A  
3/8" DIA. X 1/16" DRILL START IN 4 LOCATIONS  
GRATE - CAST GRAY IRON ASTM A-48, CLASS 35B

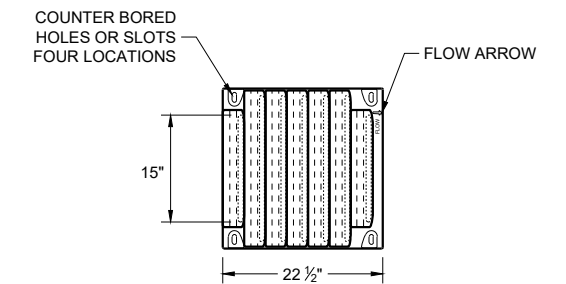

**BOLT DOWN GRATE FOR TYPE "V" COVER**

NOTES: ALL HARDWARE TO BE SUPPLIED BY CASTING MANUFACTURER NOTED AS TYPE "V-B" ON DRAINAGE TABLE

TAP 1/2" -13 HOLES IN FOUR LOCATIONS IN FRAME TO BOLT GRATE FRAME - CAST GRAY IRON ASTM A48 CLASS 40A

GRATE - CAST DUCTILE IRON ASTM A536, 55+KSI YIELD BOLTS - 1/2" -13 STAINLESS STEEL BOLTS WITH WASHERS TORQUE BOLTS TO MANUFACTURER SPECIFICATION DO NOT OVERTIGHTEN.

**INLET COVERS  
TYPES F, HM, HM-S, S, T, V,  
HM-GJ AND HM-GJ-S**

STATE OF WISCONSIN  
DEPARTMENT OF TRANSPORTATION

APPROVED  
July 2023 /S/ Rodney Taylor  
DATE ROADWAY STANDARDS DEVELOPMENT  
FHWA UNIT SUPERVISOR

SDD 08A05-20C

**GENERAL NOTES**

DETAILS OF CONSTRUCTION, MATERIALS AND WORKMANSHIP NOT SHOWN ON THIS DRAWING SHALL CONFORM TO THE PERTINENT REQUIREMENTS OF THE STANDARD SPECIFICATIONS AND THE APPLICABLE SPECIAL PROVISIONS.

DETAIL DRAWINGS FOR PROPOSED ALTERNATE DESIGNS FOR MANHOLE COVERS SHALL BE SUBMITTED TO THE ENGINEER FOR APPROVAL PROVIDING THAT SUCH ALTERNATE DESIGNS MAKE PROVISION FOR EQUIVALENT CAPACITY AND STRENGTH.

ROUND FRAMES AND COVERS SHALL HAVE CONTINUOUSLY MACHINED BEARING SURFACES TO PREVENT ROCKING AND RATTLING.

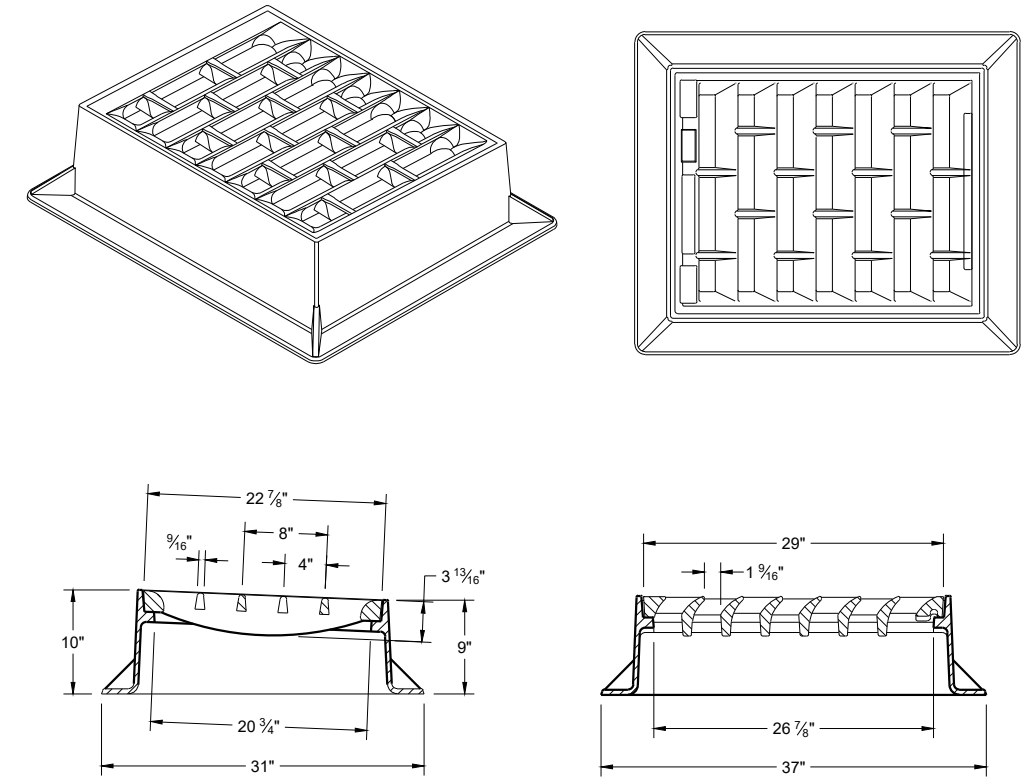
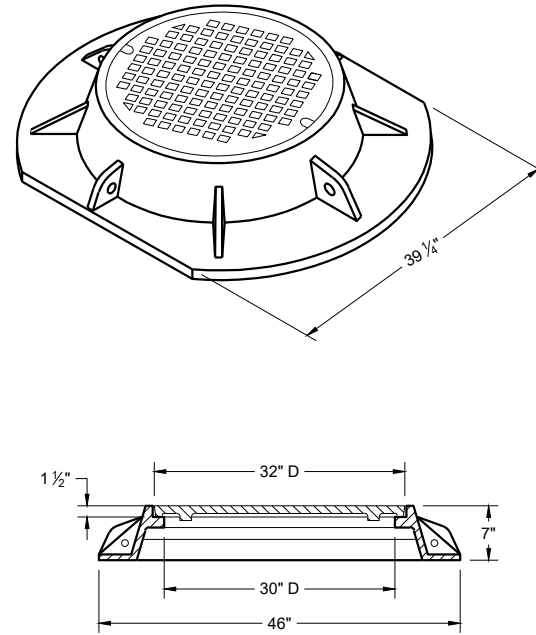
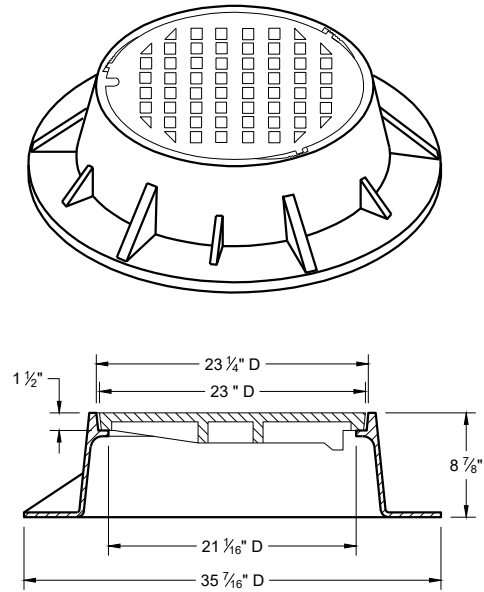
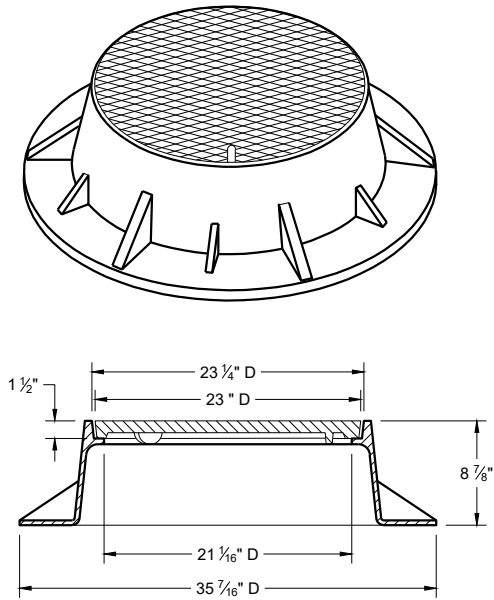

**TYPE "K"**

**INLET COVER TYPE "BW"**

6

6

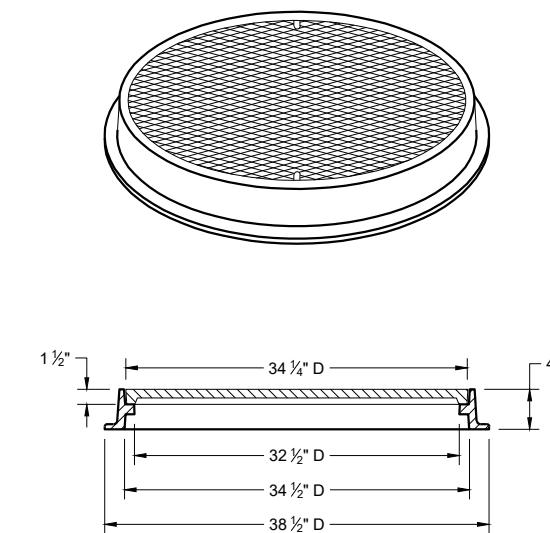
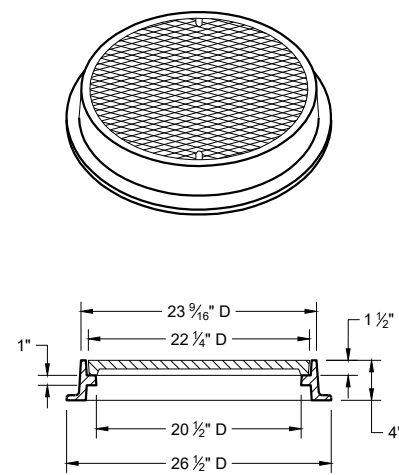
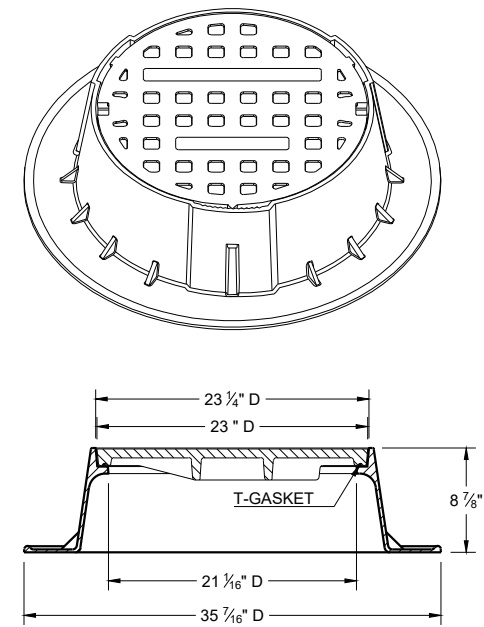
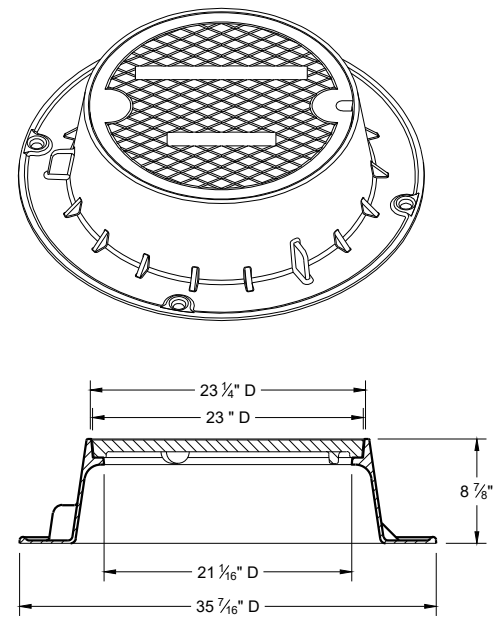

**TYPE "J"**

NOTE: EITHER CASTING IS ACCEPTABLE

**TYPE "J" SPECIAL**

TYPE "B" NON-ROCKING SELF-SEAL LID (NOTED AS TYPE J-S ON THE DRAINAGE TABLE)

NOTE: EITHER CASTING IS ACCEPTABLE

**TYPE "L"**

**TYPE "M"**

**INLET COVERS TYPES BW  
MANHOLE COVERS TYPES K,  
J, J-S, L, AND M**

STATE OF WISCONSIN  
DEPARTMENT OF TRANSPORTATION

APPROVED  
July 2023 /S/ Rodney Taylor  
DATE ROADWAY STANDARDS DEVELOPMENT  
FHWA UNIT SUPERVISOR

SDD 08A05-20d

SDD 08A05-20d

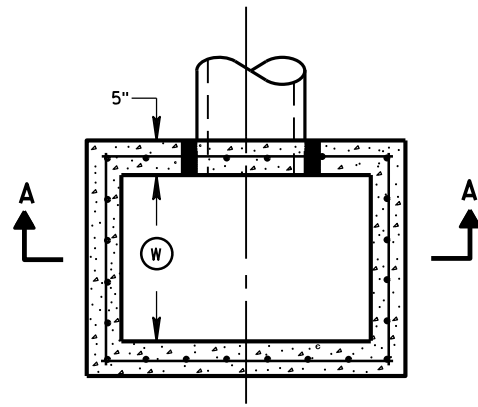

PLAN VIEW

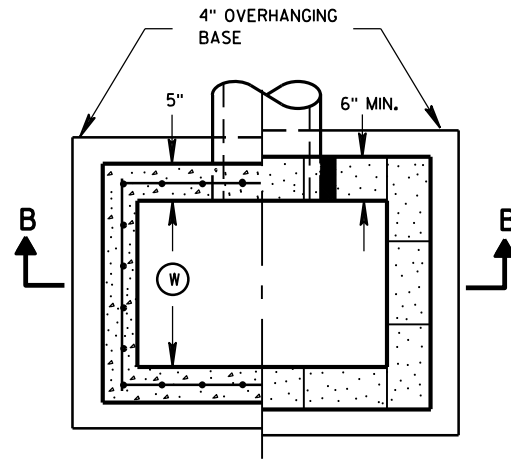

PLAN VIEW

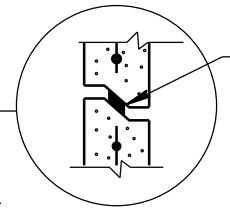

RISER JOINTS TO BE SEALED WITH A BUTYL RUBBER SEAL PER SEALANT MANUFACTURERS RECOMMENDATIONS CONFORMING TO ASTM C 990 (TYP)

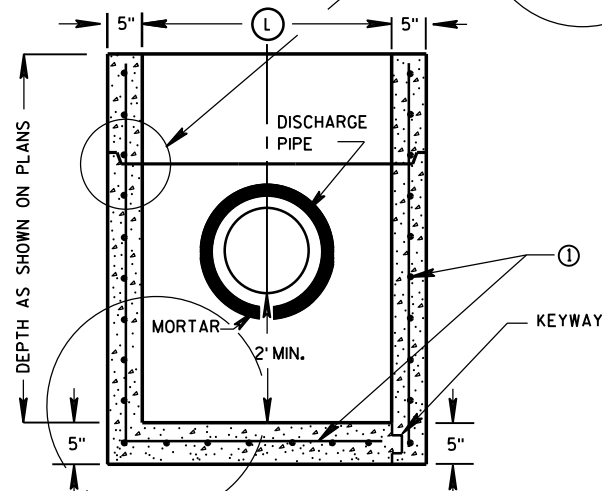

PRECAST REINFORCED CONCRETE WITH MONOLITHIC BASE

SECTION A-A

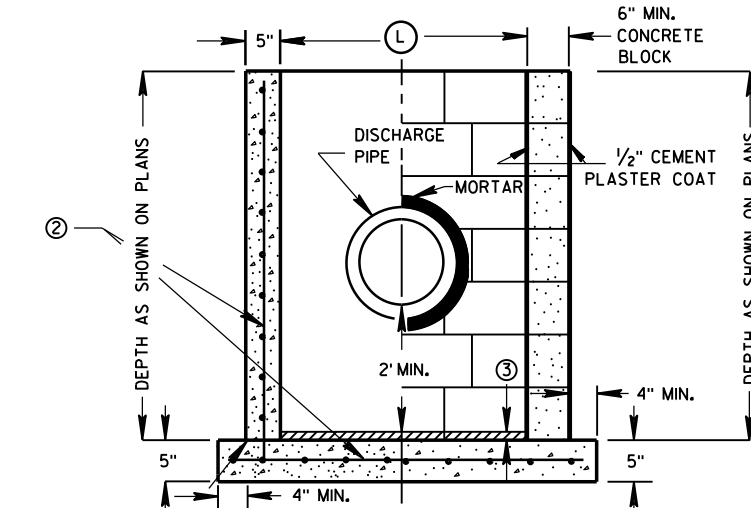

CAST-IN-PLACE REINFORCED CONCRETE

CONCRETE BLOCK ON CAST-IN-PLACE WITH PRECAST REINFORCED CONCRETE BASE ①

SECTION B-B

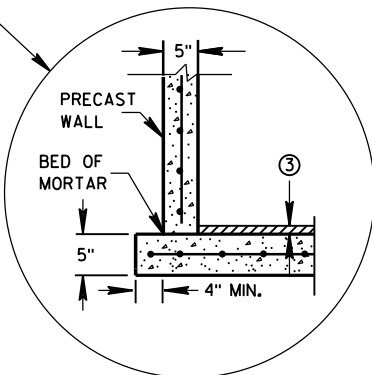

SEPARATE PRECAST REINFORCED CONCRETE BASE OPTION

**GENERAL NOTES**

DETAILS OF CONSTRUCTION, MATERIALS AND WORKMANSHIP NOT SHOWN ON THIS DRAWING SHALL CONFORM TO THE PERTINENT REQUIREMENTS OF THE STANDARD SPECIFICATIONS AND THE APPLICABLE SPECIAL PROVISIONS.

UNLESS OTHERWISE AUTHORIZED IN WRITING BY THE ENGINEER, THE CONTRACTOR SHALL NOT ORDER AND DELIVER PRECAST CATCH BASIN UNITS REQUIRED FOR THE PROJECT UNTIL A LIST OF SIZES IS FURNISHED BY THE ENGINEER.

DETAILED DRAWINGS FOR PROPOSED ALTERNATE DESIGNS FOR UNDERGROUND DRAINAGE STRUCTURES SHALL BE SUBMITTED TO THE ENGINEER FOR APPROVAL PROVIDING THAT SUCH ALTERNATE DESIGNS MAKE PROVISION FOR EQUIVALENT CAPACITY AND STRENGTH.

ALL PRECAST CATCH BASIN UNITS SHALL CONFORM TO THE PERTINENT REQUIREMENTS OF ASTM C 913.

ALL DRAINAGE STRUCTURES ARE DESIGNATED ON THE PLANS AS "MANHOLES 3X3-L", "CATCH BASINS 4-B", "INLETS 2X3-H", ETC. THE FIRST NUMBERS DESIGNATES THE SIZE OF THE STRUCTURE, AND THE FOLLOWING LETTER DESIGNATES THE TYPE OF COVER TO BE USED TO COMPRISE THE COMPLETE UNIT.

BASES SHALL BE PLACED ON A BED OF MATERIAL AT LEAST 6 INCHES IN DEPTH, WHICH MEETS THE REQUIREMENTS OF FOUNDATION BACKFILL. THIS BEDDING SHALL BE COMPACTED AND PROVIDE UNIFORM SUPPORT FOR THE ENTIRE AREA OF THE BASE.

ALL BAR STEEL REINFORCEMENT SHALL BE EMBEDDED 2 INCHES CLEAR UNLESS OTHERWISE SHOWN OR NOTED.

PRECAST REINFORCED RISERS SHALL HAVE A TONGUE AND GROOVE JOINT WITH TONGUE UP OR DOWN.

4" OVERHANGING BASES ARE REQUIRED FOR CAST-IN-PLACE REINFORCED CONCRETE AND CONCRETE BLOCK INSTALLATIONS. 4" OVERHANG IS REQUIRED WHEN SEPARATE PRECAST BASE IS PROVIDED. OVERHANG IS NOT REQUIRED ON PRECAST STRUCTURES WITH AN INTEGRAL OR MONOLITHIC BASE.

MAXIMUM INSIDE PIPE DIAMETER DETERMINED BY 3" CLEARANCE ON EACH SIDE OF THE OUTSIDE WALL OF THE PIPE. SEE DETAIL "A". ASSUMES PIPE ENTERS PERPENDICULAR TO THE STRUCTURE.

- ① FOR PRECAST CATCH BASINS PROVIDE REINFORCING STEEL IN ACCORDANCE TO ASTM C 913.
- ② CONTRACTOR TO PROVIDE DRAWING(S) STAMPED BY A PROFESSIONAL ENGINEER FOR STEEL REINFORCING DESIGN FOR CAST-IN-PLACE STRUCTURES.
- ③ 1" CONCRETE KEY POURED AFTER INSTALLATION. 2" SUMP MEASURED FROM TOP OF KEY.

**CATCH BASIN COVER MATRIX**

CATCH BASIN SIZE	INLET COVER TYPE		F	ALL H'S
	WIDTH (W) (FT)	LENGTH (L) (FT)		
2X3-FT	2	3		X
2.5X3-FT	2.5	3	X	

**PIPE MATRIX**

CATCH BASIN SIZE	MAXIMUM INSIDE PIPE DIAMETER FOR TWO PIPES	
	WIDTH (IN)	LENGTH (IN)
2X3-FT	12	24
2.5X3-FT	18	24

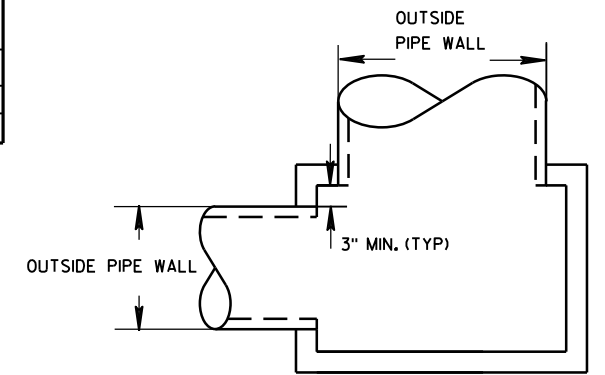

DETAIL "A"

CATCH BASINS 2X3-FT AND 2.5X3-FT

STATE OF WISCONSIN  
DEPARTMENT OF TRANSPORTATION

APPROVED  
DATE: Sept., 2016 /S/ Rodney Taylor  
ROADWAY STANDARDS DEVELOPMENT  
UNIT SUPERVISOR

**CATCH BASINS 2X3-FT AND 2.5X3-FT**

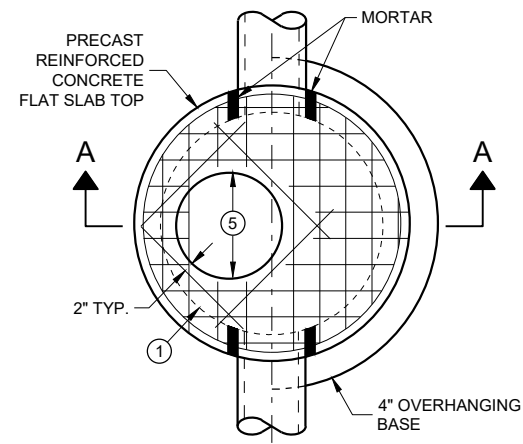

PLAN VIEW CIRCULAR OPENING

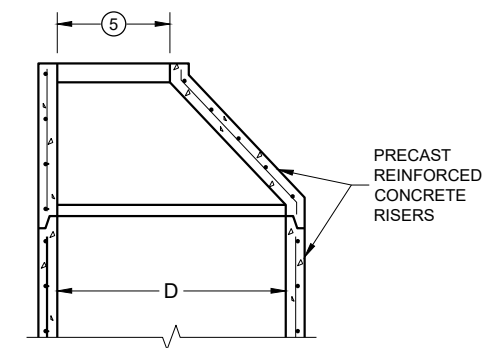

OPTIONAL PRECAST REINFORCED CONCRETE ECCENTRIC TOP

MANHOLE COVER OPENING MATRIX

MANHOLE COVER TYPE OPENING SIZE (FT.)	C	ALL J'S	K	L	M
2 DIA.	X	X		X	
3 DIA.			X		X

PIPE MATRIX

MANHOLE SIZE (DIA.)	MAXIMUM INSIDE PIPE DIAMETER FOR TWO PIPES		MINIMUM WALL THICKNESS (IN)	MINIMUM PRECAST FLAT SLAB TOP AND BASE THICKNESS
	180° SEPARATION (IN)	90° SEPARATION (IN)		
3-FT	15	12	4	6
4-FT	24	18	4	6
5-FT	36	24	5	8
6-FT	42	36	6	8
7-FT	48	36/42*	7	8
8-FT	60	42	8	8
9-FT	66	54	9	10
10-FT	72	60	10	10

\*A 36" PIPE AND A 42" PIPE CAN BE PLACED WITHIN 90 DEGREES. SEE MINIMUM HORIZONTAL PIPE SEPARATION DETAIL.

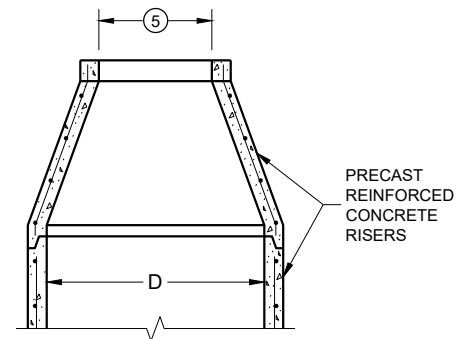

OPTIONAL PRECAST REINFORCED CONCRETE CONCENTRIC TOP

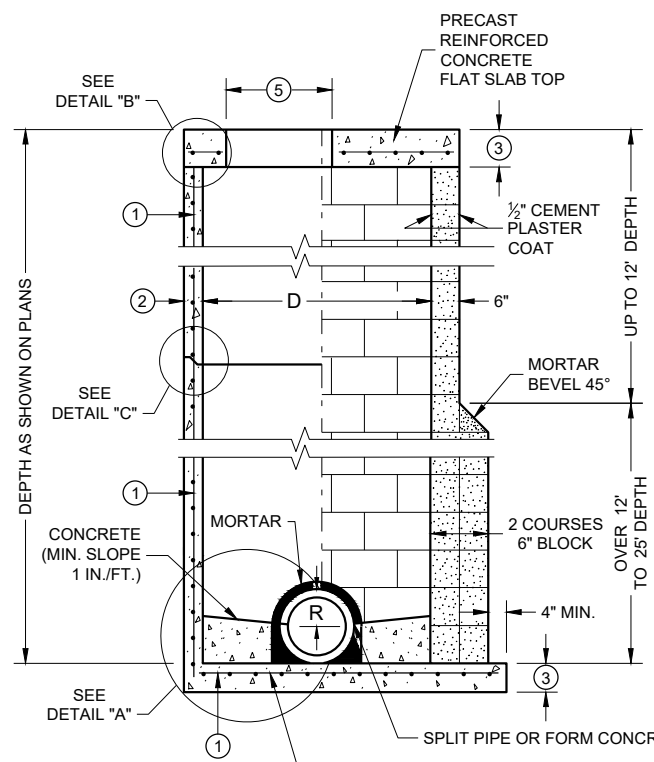

SECTION A - A

PRECAST REINFORCED CONCRETE WITH MONOLITHIC BASE

CONCRETE BLOCK WITH CAST IN PLACE OR PRECAST REINFORCED CONCRETE BASE ①

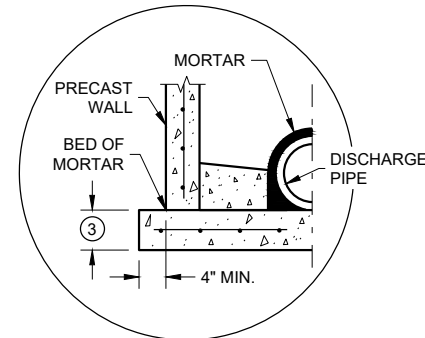

SEPARATE PRECAST REINFORCED CONCRETE BASE OPTION

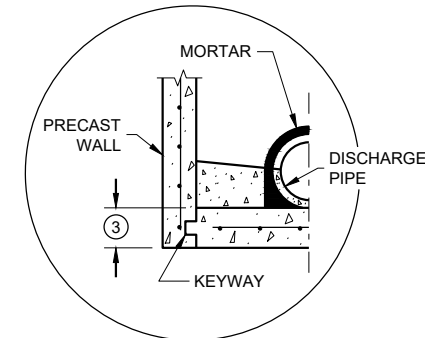

PRECAST REINFORCED CONCRETE WITH INTEGRAL BASE OPTION

DETAIL "A"

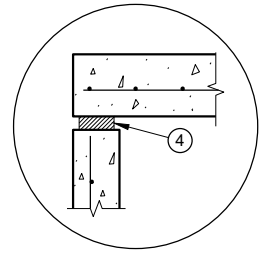

TOP WITH PLAIN END JOINT

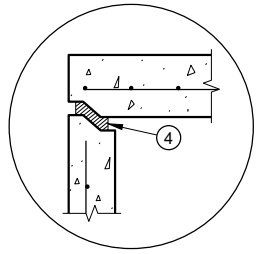

TOP WITH TONGUE AND GROOVE JOINT

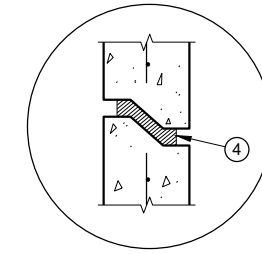

RISER WITH TONGUE AND GROOVE JOINT

DETAIL "B"

DETAIL "C"

GENERAL NOTES

DETAILS OF CONSTRUCTION, MATERIALS AND WORKMANSHIP NOT SHOWN ON THIS DRAWING SHALL CONFORM TO THE PERTINENT REQUIREMENTS OF THE STANDARD SPECIFICATIONS AND THE APPLICABLE SPECIAL PROVISIONS.

UNLESS OTHERWISE AUTHORIZED IN WRITING BY THE ENGINEER, THE CONTRACTOR SHALL NOT ORDER AND DELIVER PRECAST MANHOLE UNITS REQUIRED FOR THE PROJECT UNTIL A LIST OF SIZES IS FURNISHED BY THE ENGINEER.

DETAILED DRAWINGS FOR PROPOSED ALTERNATE DESIGNS FOR UNDERGROUND DRAINAGE STRUCTURES SHALL BE SUBMITTED TO THE ENGINEER FOR APPROVAL PROVIDING THAT SUCH ALTERNATE DESIGNS MAKE PROVISION FOR EQUIVALENT CAPACITY AND STRENGTH.

ALL DRAINAGE STRUCTURES ARE DESIGNATED ON THE PLANS AS "MANHOLES 3X3-L", "CATCH BASINS 4-B", "INLETS 2X3-H", ETC. THE FIRST NUMBERS DESIGNATE THE SIZE OF THE STRUCTURE, AND THE FOLLOWING LETTER DESIGNATES THE TYPE OF COVER TO BE USED TO COMPRISE THE COMPLETE UNIT.

BASES SHALL BE PLACED ON A BED OF MATERIAL AT LEAST 6 INCHES IN DEPTH, WHICH MEETS THE REQUIREMENTS OF FOUNDATION BACKFILL. THIS BEDDING SHALL BE COMPACTED AND PROVIDE UNIFORM SUPPORT FOR THE ENTIRE AREA OF THE BASE.

PRECAST REINFORCED CONCRETE CONE TOPS (ECCENTRIC OR CONCENTRIC) OR PRECAST REINFORCED CONCRETE FLAT SLAB TOPS MAY BE USED ON CONCRETE BLOCK STRUCTURES.

ECCENTRIC CONE TOPS MAY BE USED ON ALL STRUCTURES. CONCENTRIC CONE TOPS SHALL BE USED ONLY ON STRUCTURES 5 FEET OR LESS IN DEPTH UNLESS OTHERWISE DIRECTED BY THE ENGINEER.

STEPS MEETING AASHTO M199 AND THE FOLLOWING REQUIREMENTS SHALL BE INSTALLED IN ALL STRUCTURES OVER 5 FEET IN DEPTH: 16 INCH C-C MAXIMUM SPACING; PROJECT A MINIMUM CLEAR DISTANCE OF 4 INCHES FROM THE WALL AT THE POINT OF EMBEDMENT; MINIMUM LENGTH OF 10 INCHES; MINIMUM WALL EMBEDMENT OF 3 INCHES. FERROUS METAL STEPS NOT PAINTED OR TREATED TO RESIST CORROSION SHALL HAVE A MINIMUM CROSS SECTIONAL DIMENSION OF 1 INCH.

STEPS OF APPROVED POLYPROPYLENE PLASTIC COATED REINFORCEMENT BAR ARE ACCEPTABLE. REINFORCING BAR MUST BE A MINIMUM OF 1/2 INCH AND MEET THE REQUIREMENTS OF ASTM A615.

CERTIFICATION SHALL BE PROVIDED THAT INSTALLED STEPS WHEN TESTED IN ACCORDANCE WITH SECTION 10 OF AASHTO T280 CAN WITHSTAND A VERTICAL LOAD OF 800 LBS. AND A HORIZONTAL LOAD OF 400 LBS.

ALL BAR STEEL REINFORCEMENT SHALL BE EMBEDDED 2 INCHES CLEAR UNLESS OTHERWISE SHOWN OR NOTED.

ALL PRECAST MANHOLE UNITS SHALL CONFORM TO THE PERTINENT REQUIREMENTS OF AASHTO DESIGNATION M199.

PRECAST REINFORCED RISERS SHALL HAVE A TONGUE AND GROOVE JOINT WITH TONGUE UP OR DOWN.

CONCRETE BLOCK WILL NOT BE PERMITTED FOR STRUCTURES GREATER THAN 4 FEET IN DIAMETER.

4" OVERHANGING BASES ARE REQUIRED FOR ALL CONCRETE BLOCK INSTALLATIONS. 4" OVERHANG IS REQUIRED WHEN SEPARATE PRECAST BASE IS PROVIDED. OVERHANG IS NOT REQUIRED ON PRECAST STRUCTURES WITH AN INTEGRAL OR MONOLITHIC BASE.

FOR ADDITIONAL CONFIGURATIONS, MAINTAIN A MINIMUM OF 12 INCHES AS MEASURED FROM THE INSIDE OF THE STRUCTURE WALL BETWEEN THE OUTSIDE PIPE WALLS OF ADJACENT PIPES. SEE DETAIL "D".

- ① FOR PRECAST MANHOLES PROVIDE REINFORCING STEEL IN ACCORDANCE TO AASHTO M199.
- ② SEE PIPE MATRIX TABLE FOR MINIMUM WALL THICKNESS FOR PRECAST MANHOLES
- ③ SEE PIPE MATRIX TABLE FOR MINIMUM THICKNESS OF PRECAST FLAT SLAB TOPS AND BASES.
- ④ JOINTS TO BE SEALED WITH A BUTYL RUBBER SEAL PER SEALANT MANUFACTURERS RECOMMENDATIONS CONFORMING TO ASTM C 990 (TYP.).
- ⑤ SEE MANHOLE COVER OPENING MATRIX.

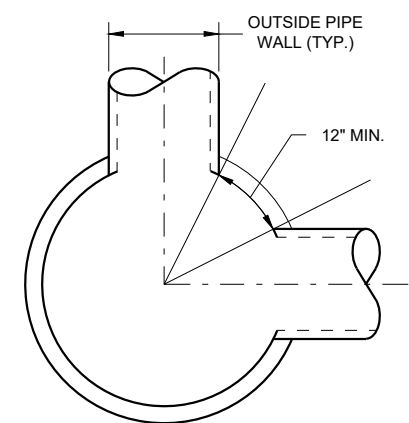

MINIMUM HORIZONTAL PIPE SEPARATION

MANHOLES, 3-FT, 4-FT  
5-FT, 6-FT, 7-FT, 8-FT, 9-FT  
AND 10-FT DIAMETER

STATE OF WISCONSIN  
DEPARTMENT OF TRANSPORTATION

APPROVED  
November 2021 /S/ Rodney Taylor  
DATE ROADWAY STANDARDS DEVELOPMENT  
ENGINEER  
FHWA

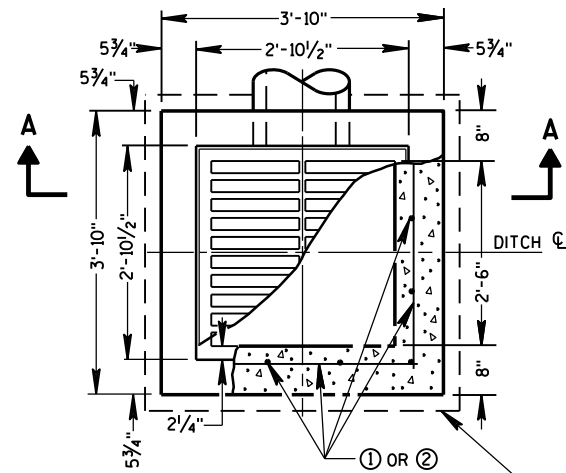

PLAN VIEW

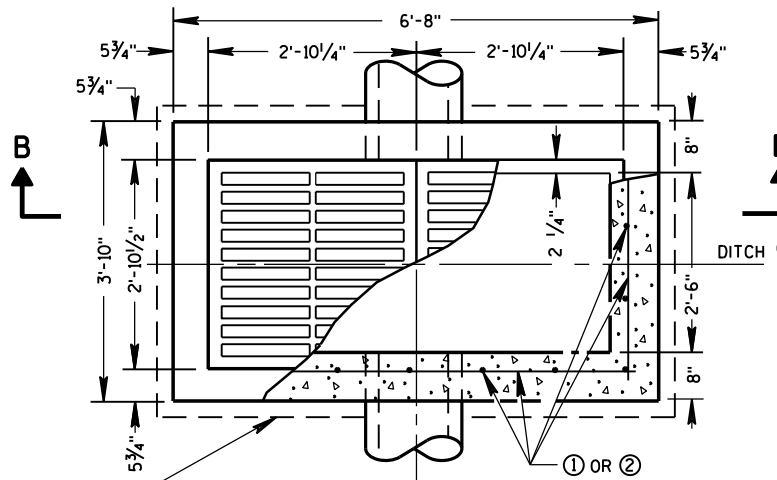

PLAN VIEW

4" OVERHANGING BASE ON REINFORCED CAST-IN-PLACE CONCRETE INLETS

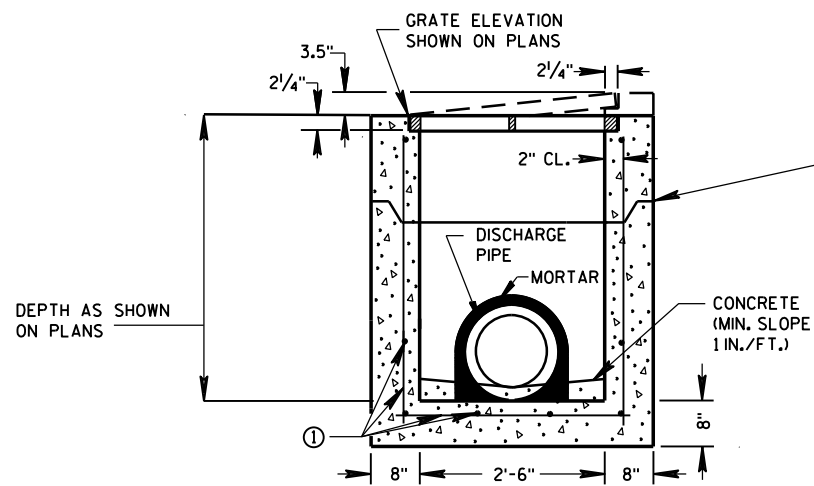

PRECAST REINFORCED CONCRETE SECTION A-A

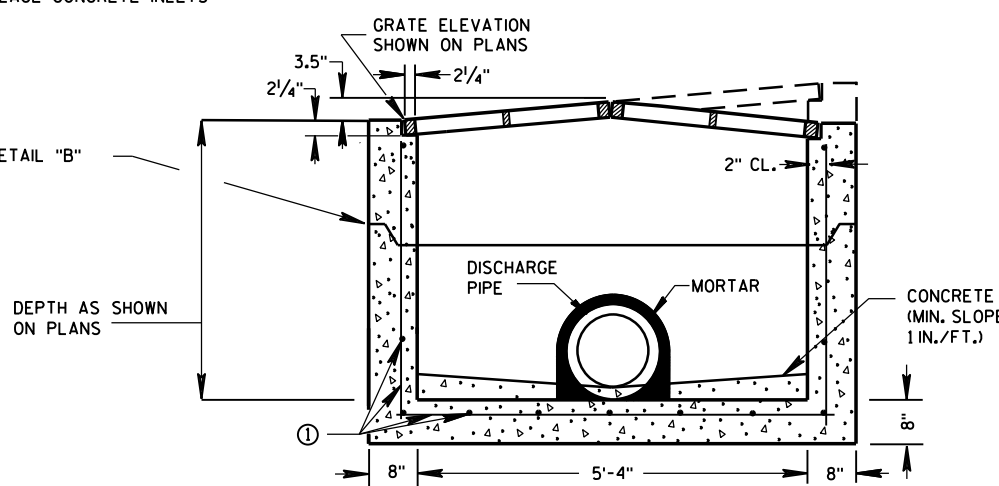

PRECAST REINFORCED CONCRETE SECTION B-B

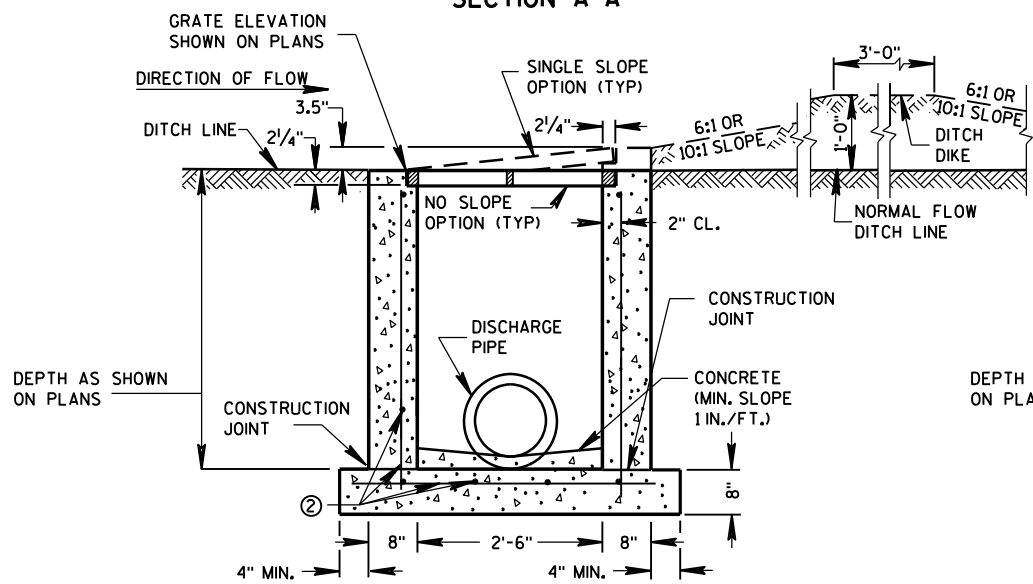

REINFORCED CAST-IN-PLACE CONCRETE SECTION A-A

INLETS MEDIAN 1 GRATE

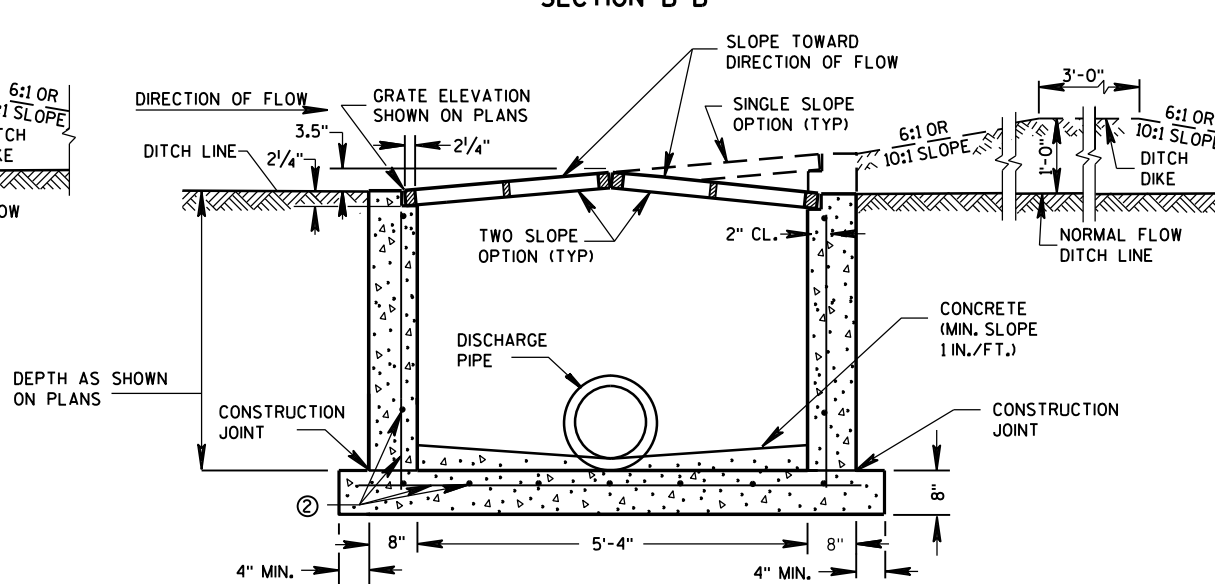

REINFORCED CAST-IN-PLACE CONCRETE SECTION B-B

INLETS MEDIAN 2 GRATE

**GENERAL NOTES**

DETAILS OF CONSTRUCTION, MATERIALS AND WORKMANSHIP NOT SHOWN ON THIS DRAWING SHALL CONFORM TO THE PERTINENT REQUIREMENTS OF THE STANDARD SPECIFICATIONS AND THE APPLICABLE SPECIAL PROVISIONS.

UNLESS OTHERWISE AUTHORIZED IN WRITING BY THE ENGINEER, THE CONTRACTOR SHALL NOT ORDER AND DELIVER PRECAST INLET UNITS REQUIRED FOR THE PROJECT UNTIL A LIST OF SIZES IS FURNISHED BY THE ENGINEER.

DETAILED DRAWINGS FOR PROPOSED ALTERNATE DESIGNS FOR INLETS WHICH MAY INCLUDE PRECAST REINFORCED CONCRETE INLETS, SHALL BE SUBMITTED TO THE ENGINEER FOR APPROVAL PROVIDING THAT SUCH ALTERNATE DESIGNS MAKE PROVISION FOR EQUIVALENT CAPACITY AND STRENGTH.

ALL MEDIAN INLETS ARE DESIGNATED ON THE PLANS AS "INLETS, IG-MS", ETC. THE FIRST NUMBER AND LETTER DESIGNATE THE TYPE OF STRUCTURE, AND THE FOLLOWING LETTERS DESIGNATE THE TYPE OF COVER TO BE USED TO COMPRISE THE COMPLETE UNIT. BASES SHALL BE PLACED ON A BED OF MATERIAL AT LEAST 6 INCHES IN DEPTH, WHICH MEETS THE REQUIREMENTS OF FOUNDATION BACKFILL. THIS BEDDING SHALL BE COMPACTED AND PROVIDE UNIFORM SUPPORT FOR THE ENTIRE AREA OF THE BASE.

ALL BAR STEEL REINFORCEMENT SHALL BE EMBEDDED 2 INCHES CLEAR UNLESS OTHERWISE SHOWN OR NOTED.

PRECAST REINFORCED RISERS SHALL HAVE A TONGUE AND GROOVE JOINT WITH TONGUE UP OR DOWN.

ALL PRECAST INLET UNITS SHALL CONFORM TO THE PERTINENT REQUIREMENTS OF ASTM C 913.

MAXIMUM INSIDE PIPE DIAMETER DETERMINED BY 3" CLEARANCE ON EACH SIDE OF THE OUTSIDE WALL OF THE PIPE. SEE DETAIL "A". ASSUMES PIPE ENTERS PERPENDICULAR TO THE STRUCTURE.

- ① FOR PRECAST INLETS PROVIDE REINFORCING STEEL IN ACCORDANCE TO ASTM C 913.
- ② CONTRACTOR TO PROVIDE DRAWING(S) STAMPED BY A PROFESSIONAL ENGINEER FOR STEEL REINFORCING DESIGN FOR CAST-IN-PLACE STRUCTURES.

**PIPE MATRIX**

INLET SIZE	MAXIMUM INSIDE PIPE DIAMETER	
	WIDTH (IN)	LENGTH (IN)
1 GRATE	18	18
2 GRATE	18	42

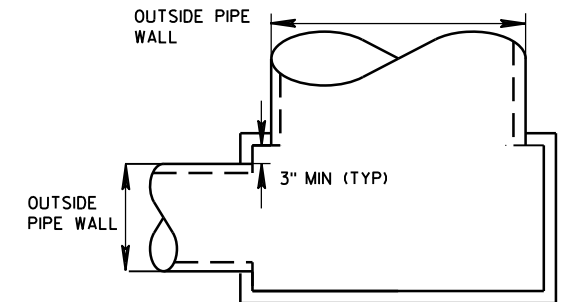

DETAIL "A"

JOINTS TO BE SEALED WITH A BUTYL RUBBER SEAL PER SEALANT MANUFACTURERS RECOMMENDATIONS CONFORMING TO ASTM C 990 (TYP)

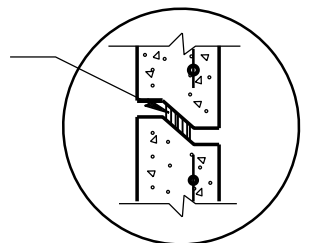

DETAIL "B"

**INLETS MEDIAN 1 AND 2 GRATE**

STATE OF WISCONSIN  
DEPARTMENT OF TRANSPORTATION

APPROVED  
Sept., 2016 /S/ Rodney Taylor  
DATE ROADWAY STANDARDS DEVELOPMENT  
FHWA UNIT SUPERVISOR

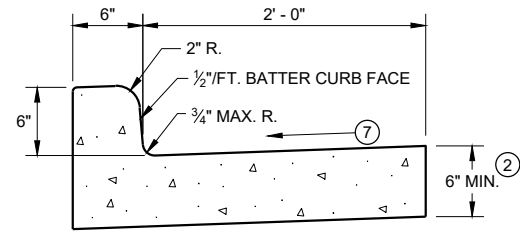

**TYPES A<sup>1</sup> & D**

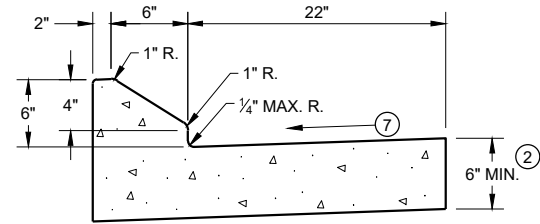

**6" SLOPED CURB TYPES G<sup>1</sup> & J**

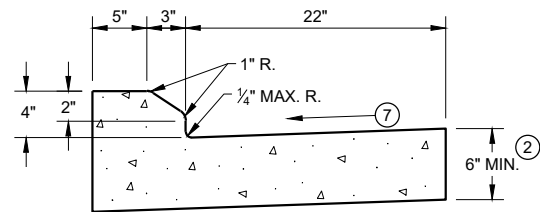

**4" SLOPED CURB TYPES G<sup>1</sup> & J**

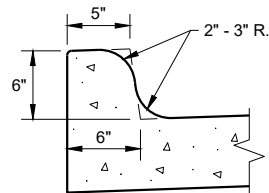

**TYPES K<sup>1</sup> & L**  
(OPTIONAL CURB SHAPE)

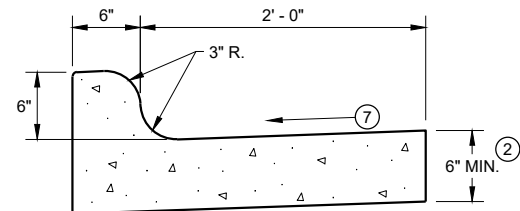

**TYPES K<sup>1</sup> & L**  
**CONCRETE CURB AND GUTTER 30"**

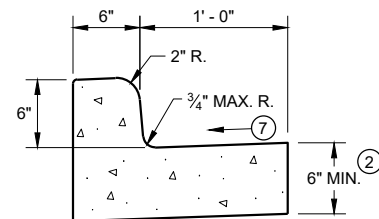

**TYPES A<sup>1</sup> & D**  
**CONCRETE CURB AND GUTTER 18"**

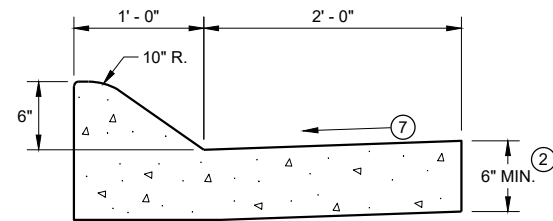

**6" SLOPED CURB TYPES A<sup>1</sup> & D**

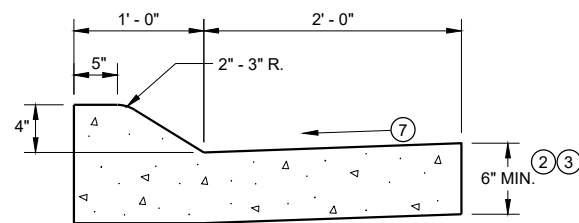

**4" SLOPED CURB TYPES A<sup>1</sup> & D**  
**CONCRETE CURB AND GUTTER 36"**

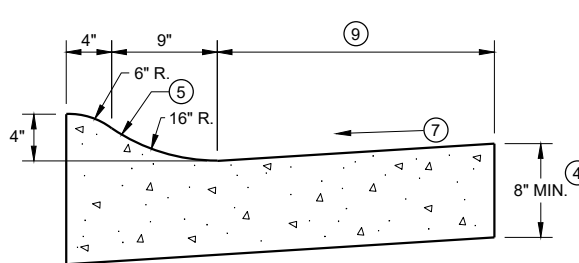

**4" SLOPED CURB TYPES R<sup>1</sup> & T**

TBT & TBTT	X
30"	22"
36"	28"

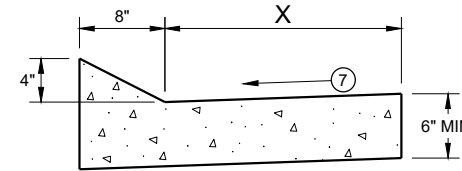

**TYPES TBT & TBTT<sup>1</sup>**  
**CONCRETE CURB AND GUTTER**

**PAVEMENT THICKNESS AND MAXIMUM CONCRETE PANEL WIDTH TABLE**

PAVEMENT THICKNESS	MAXIMUM PANEL WIDTH
LESS THAN 10"	12'
10" & ABOVE	15'

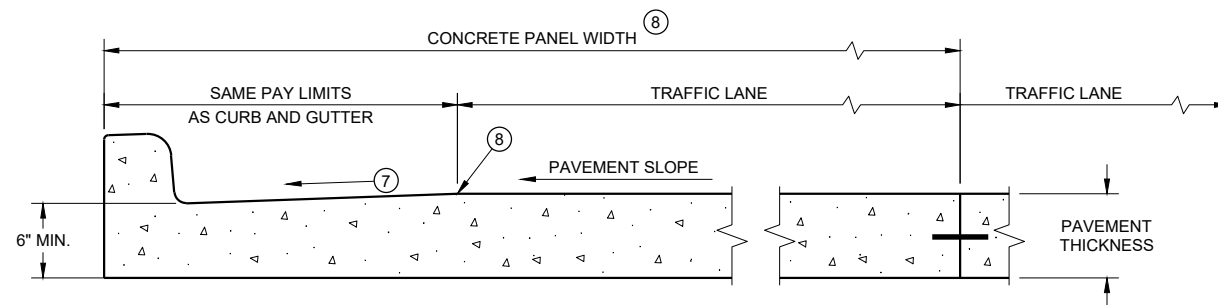

**PARTIAL SECTION OF PAVEMENT\* WITH INTEGRAL CURB AND GUTTER**

\* BIKE LANE IS NOT SHOWN

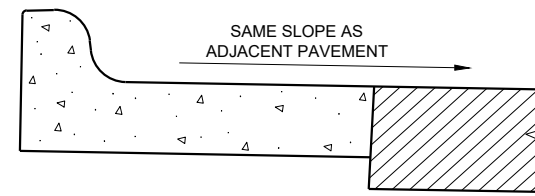

**REVERSE SLOPE GUTTER<sup>6</sup>**  
(TYPICAL FOR ALL CURB & GUTTER TYPES)

**GENERAL NOTES**

DETAILS OF CONSTRUCTION AND WORKMANSHIP NOT SHOWN ON THIS DRAWING SHALL CONFORM TO THE PERTINENT REQUIREMENTS OF THE CONTRACT.

PAVEMENT TIES AND TIE BARS SHALL BE EPOXY COATED IN CONFORMANCE WITH SUBSECTION 505.2.6.2 OF THE STANDARD SPECIFICATIONS.

INTEGRAL CURB AND GUTTER SHALL CONFORM TO THE DETAILS SHOWN FOR CONCRETE CURB AND GUTTER INCLUDING THE TRANSVERSE GUTTER SLOPE.

UNLESS OTHERWISE SHOWN ON THE TYPICAL CROSS SECTIONS, THE BASE AGGREGATE AND COMMON EXCAVATION LIMITS ARE 2' - 0" BEHIND THE BACK OF CURBS.

- ① TIE BARS ARE REQUIRED FOR CURB AND GUTTERS TYPES A, G, K, R, AND TBTT.
- ② THE BOTTOM OF CURB AND GUTTER MAY BE CONSTRUCTED EITHER LEVEL OR PARALLEL TO THE SLOPE OF THE SUBGRADE OR BASE AGGREGATE PROVIDED A 6" MINIMUM GUTTER THICKNESS IS MAINTAINED.
- ③ USE 8" MINIMUM GUTTER THICKNESS WHEN USED WITH AN ADJACENT CONCRETE TRUCK APRON PLACED BEHIND BACK OF CURB.
- ④ THE BOTTOM OF CURB AND GUTTER MAY BE CONSTRUCTED EITHER LEVEL OR PARALLEL TO THE SLOPE OF THE SUBGRADE OR BASE AGGREGATE PROVIDED A 8" MINIMUM GUTTER THICKNESS IS MAINTAINED.
- ⑤ UNLESS OTHERWISE NOTED, FOR STAKING PURPOSES THE FACE OF CURB IS 6" FROM THE BACK OF CURB.
- ⑥ WHEN REVERSE SLOPE GUTTER IS REQUIRED, THE LOCATION(S) WILL BE SHOWN ELSEWHERE IN THE PLAN.
- ⑦ USE 4% GUTTER CROSS SLOPE UNLESS OTHERWISE NOTED IN THE PLANS.
- ⑧ INCLUDE LONGITUDINAL JOINT AND TIE BARS ALONG LANE EDGE WHEN CONCRETE PANEL WIDTH EXCEEDS THE MAXIMUM WIDTH PER TABLE BELOW. LONGITUDINAL JOINT(S) ARE NOT ALLOWED WITHIN TRAFFIC LANES AND BIKE LANES. LONGITUDINAL JOINT MAY BE SAWED.
- ⑨ CONCRETE CURB AND GUTTER 4-INCH SLOPED 30-INCH TYPE "R" AND "T" = 17 INCHES  
CONCRETE CURB AND GUTTER 4-INCH SLOPED 36-INCH TYPE "R" AND "T" = 23 INCHES

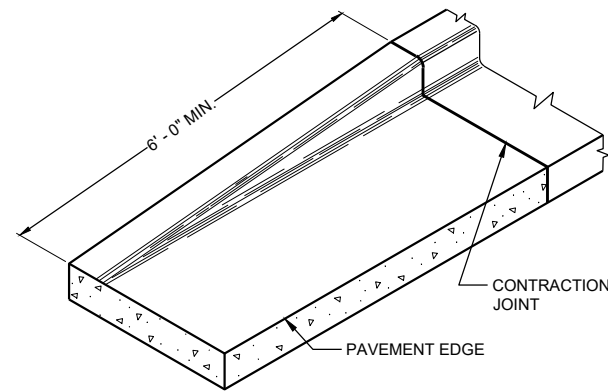

**END SECTION CURB AND GUTTER**

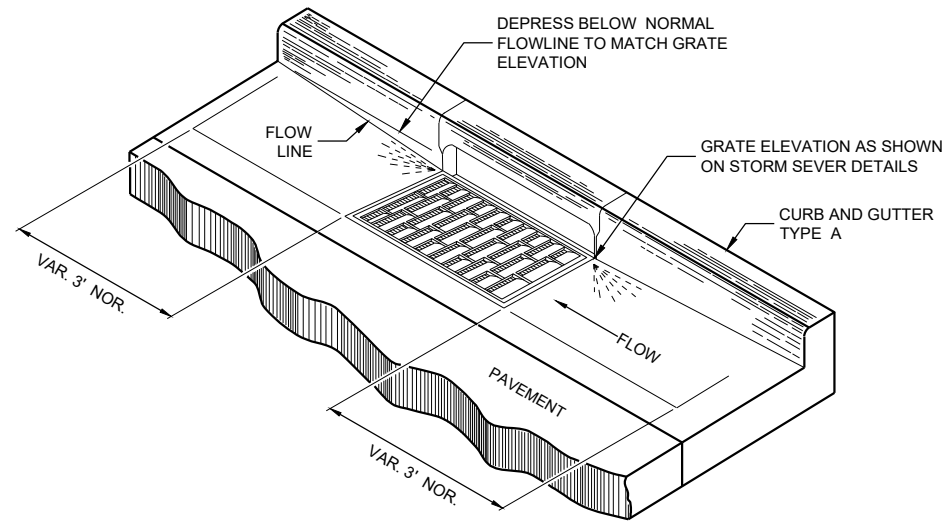

**DETAIL OF CURB AND GUTTER AT INLETS**

(TYPICAL H INLET COVER SHOWN)

**GENERAL NOTES**

DETAILS OF CONSTRUCTION AND WORKMANSHIP NOT SHOWN ON THIS DRAWING SHALL CONFORM TO THE PERTINENT REQUIREMENTS OF THE CONTRACT.

PAVEMENT TIES AND TIE BARS SHALL BE EPOXY COATED IN CONFORMANCE WITH SUBSECTION 505.2.6.2 OF THE STANDARD SPECIFICATIONS.

UNLESS OTHERWISE SHOWN ON THE TYPICAL CROSS SECTIONS, THE BASE AGGREGATE AND COMMON EXCAVATION LIMITS ARE 2' - 0" BEHIND THE BACK OF CURBS.

- ① TIE BARS ARE REQUIRED FOR CURB AND GUTTERS TYPES A, G, K, R, AND TBTT.
- ② THE BOTTOM OF CURB AND GUTTER MAY BE CONSTRUCTED EITHER LEVEL OR PARALLEL TO THE SLOPE OF THE SUBGRADE OR BASE AGGREGATE PROVIDED A 6" MINIMUM GUTTER THICKNESS IS MAINTAINED.
- ⑩ REFER TO SDD 08D18 AND 08D19 FOR ADDITIONAL DRIVEWAY ENTRANCE CURB DETAILS.
- ⑪ PLACE 1" THICK EXPANSION JOINT MATERIAL BETWEEN VERTICAL FACE CURB TYPES EXTENDING FROM THE TOP OF CURB TO 1 INCH BELOW THE ADJOINING CONCRETE SURFACE. RIGID CONCRETE STRUCTURES INCLUDE RAISED CONCRETE MEDIANS, CONCRETE SAFETY ISLANDS, SPLITTER ISLANDS, OR LOCATIONS IDENTIFIED ON THE PLANS.

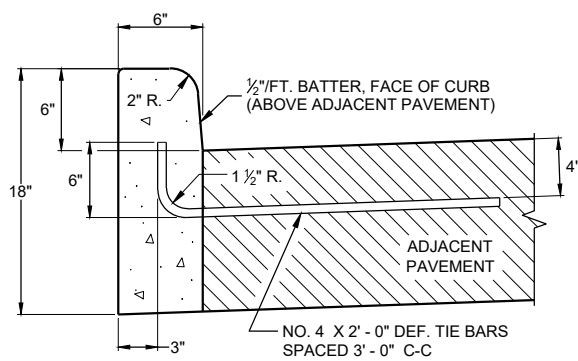

**TYPES A<sup>①</sup> & D**

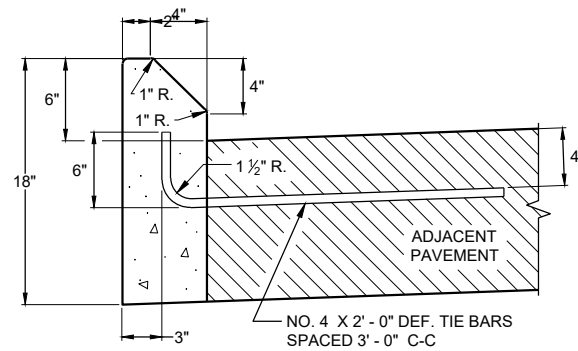

**TYPES G<sup>①</sup> & J  
CONCRETE CURB**

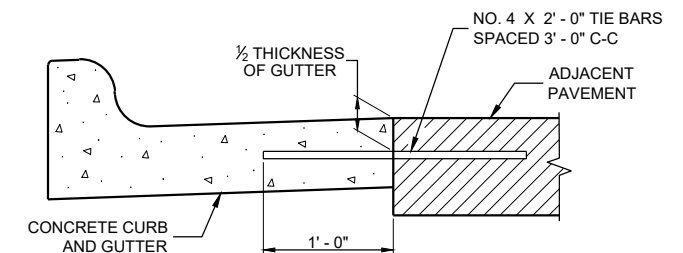

**TYPICAL TIE BAR LOCATION<sup>①</sup>**

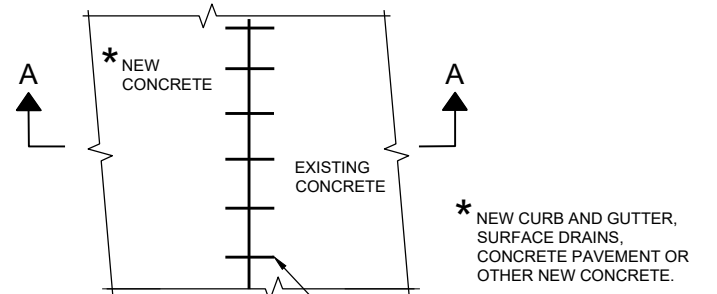

**PLAN VIEW**

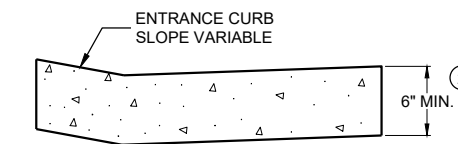

**DRIVEWAY ENTRANCE CURB<sup>⑩</sup>  
(WHEN DIRECTED BY THE ENGINEER)**

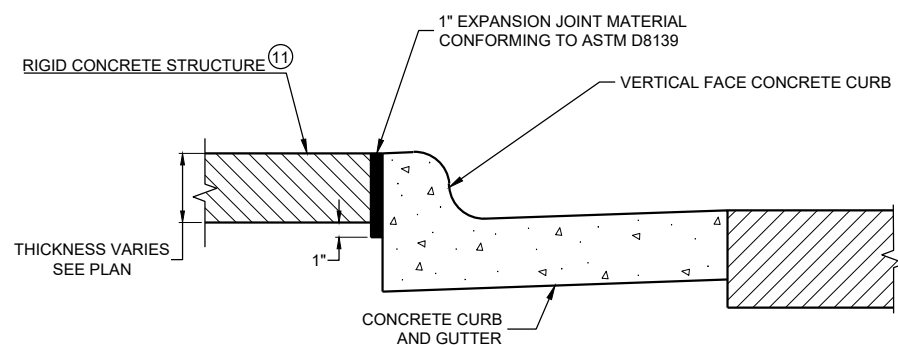

**EXPANSION JOINT DETAIL FOR VERTICAL CURB ABUTTING A RIGID STRUCTURE<sup>⑪</sup>**

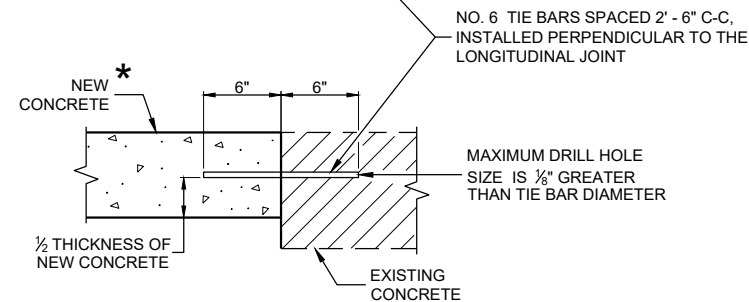

**SECTION A - A  
TIE BARS DRILLED INTO EXISTING PAVEMENT**

**CONCRETE CURB, TIES AND CURB AND GUTTER APPLICATIONS**

STATE OF WISCONSIN  
DEPARTMENT OF TRANSPORTATION

APPROVED  
DATE May 2023 /S/ Rodney Taylor  
ROADWAY STANDARDS DEVELOPMENT ENGINEER

FHWA



**GENERAL NOTES**

DETAILS OF CONSTRUCTION, MATERIALS AND WORKMANSHIP NOT SHOWN ON THIS DRAWING SHALL CONFORM TO THE PERTINENT REQUIREMENTS OF THE STANDARD SPECIFICATIONS AND THE APPLICABLE SPECIAL PROVISIONS.

ALL STEEL REINFORCEMENT SHALL BE EMBEDDED 2 INCHES CLEAR UNLESS OTHERWISE SHOWN OR NOTED.

- ① USE A JOINT SEALANT CONFORMING TO STANDARD SPECIFICATION 415.2.6.
- ② NO. 4 X 2' - 0" TIE BARS SPACED AT 12" C-C TO BE PLACED BY BRIDGE CONTRACTOR OR DRILLED TIE BARS PLACED AS DIRECTED BY THE ENGINEER.
- ③ PAVED CONCRETE SHOULDER (SDD 13A03) OR CONCRETE DRAINAGE SLAB.
- ④ CONCRETE PAVEMENT APPROACH SLAB (SHOWN) OR STRUCTURE APPROACH SLAB AND CONCRETE PAVEMENT APPROACH SLAB. SEE SDD 13B02.
- ⑤ PAVED CONCRETE SHOULDER (SDD 13A03) OR ASPHALT SHOULDER.

- ⑥ CONCRETE CURB AND GUTTER 4-INCH SLOPED 36-INCH TYPE TBT OR TBTT. USE TYPE TBTT CURB WITH NO. 4 X 2' - 0" TIE BARS SPACED AT 3' - 0" C-C ONLY WHEN ADJACENT TO CONCRETE PAVEMENTS.
- ⑦ PLACE FLUME BEFORE MSG THRIE BEAM TRANSITION POST 1 (SEE SDD 14B45)
- ⑧ CENTER FLUME BETWEEN POSTS. 6-INCH MINIMUM SEPARATION FROM OUTSIDE EDGE OF FLUME TO POSTS.
- ⑨ MINIMUM REINFORCEMENT SHALL BE 4" X 4" - W3.0 X W3.0 OR NO. 3 BARS LONGITUDINAL AND TRANSVERSE SPACING 12" C-C.
- ⑩ SEE ROADWAY PLANS FOR FLUME LOCATION.
- ⑪ START CURB AND GUTTER TRANSITION OR END SECTION.
- ⑫ DEPRESS FLOW LINE (SEE DETAIL)

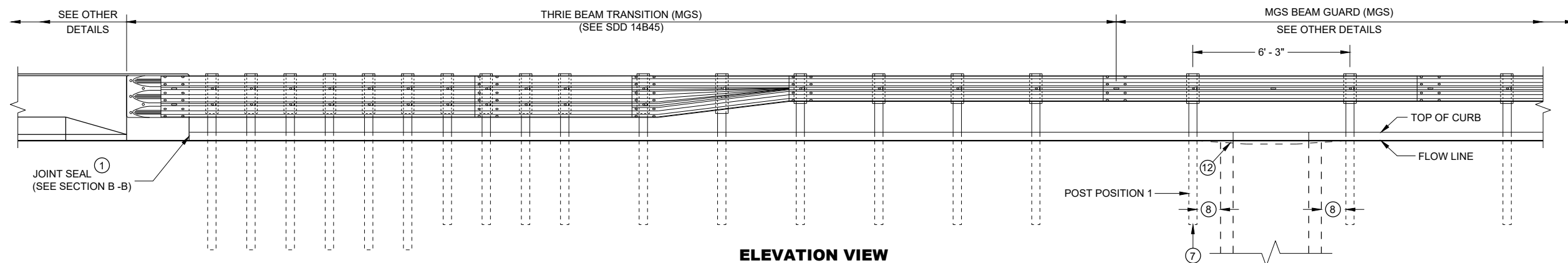
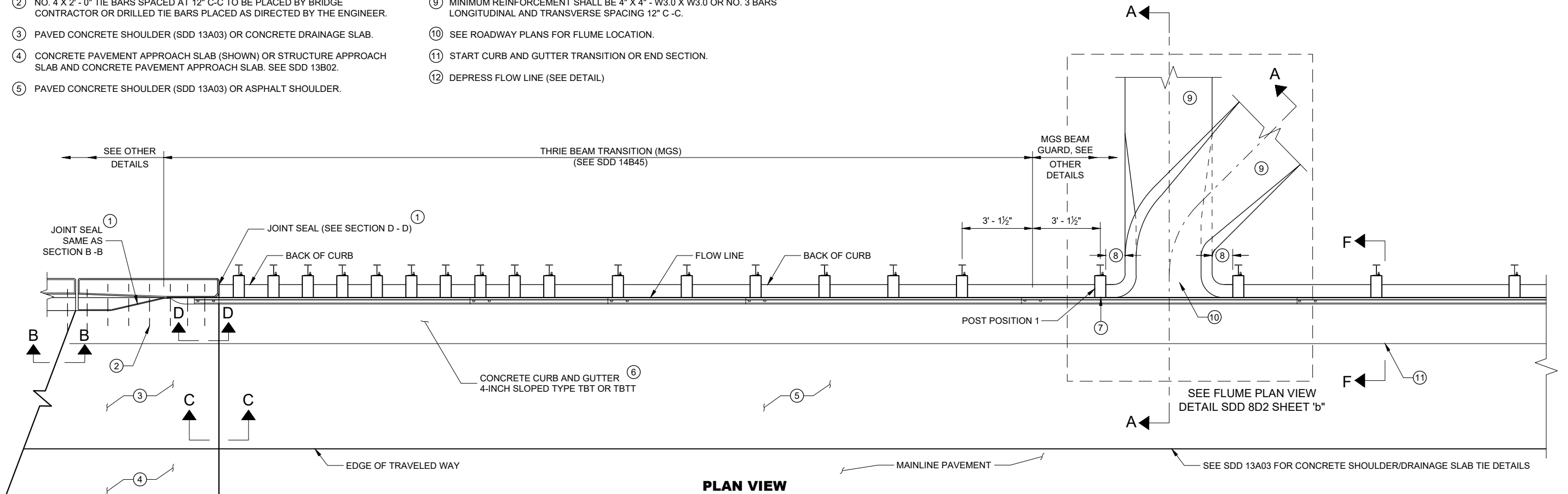

**CONCRETE SURFACE  
DRAINS FLUME TYPE  
AT STRUCTURES**

STATE OF WISCONSIN  
DEPARTMENT OF TRANSPORTATION

6

6

SDD 08D02 - 08a

SDD 08D02 - 08a

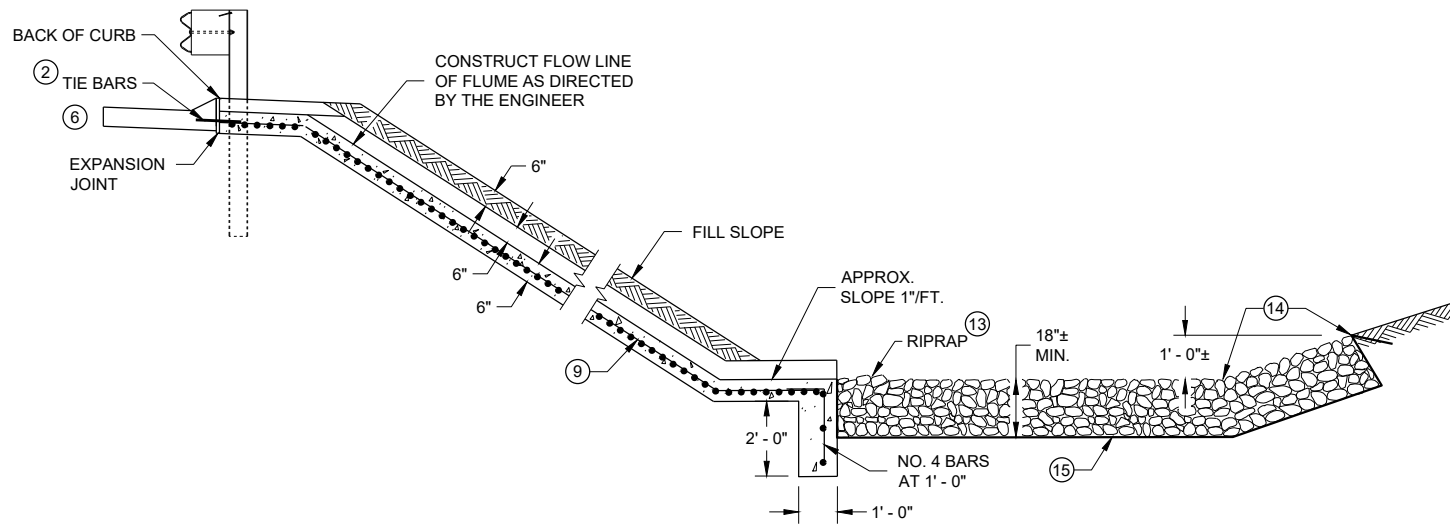

**SECTION A - A**

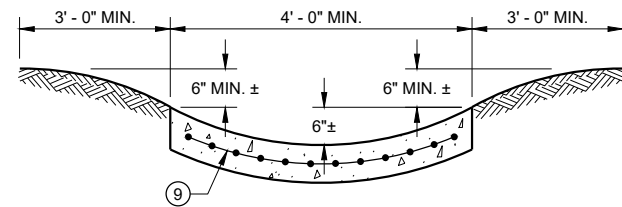

**SECTION G - G**

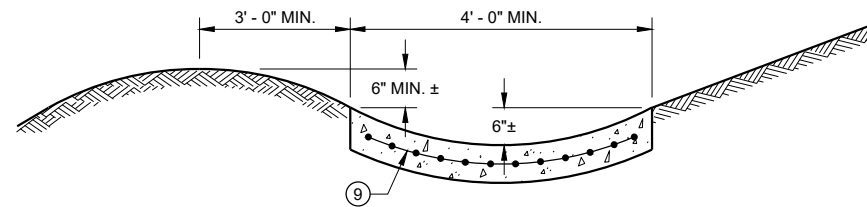

**SECTION H - H**

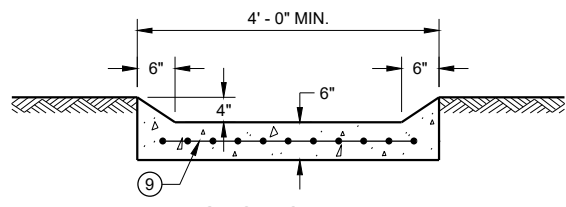

**SECTION I - I**

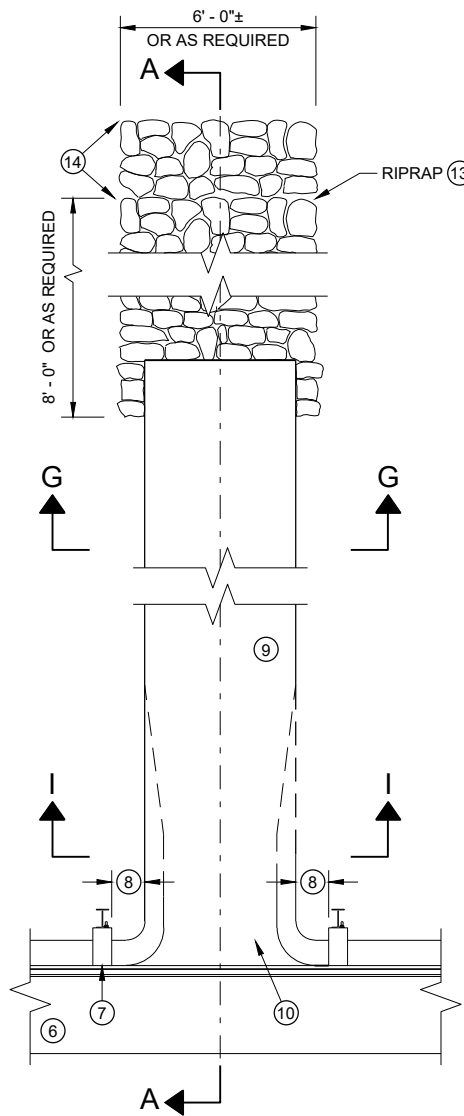

**PLAN VIEW PERPENDICULAR FLUME**

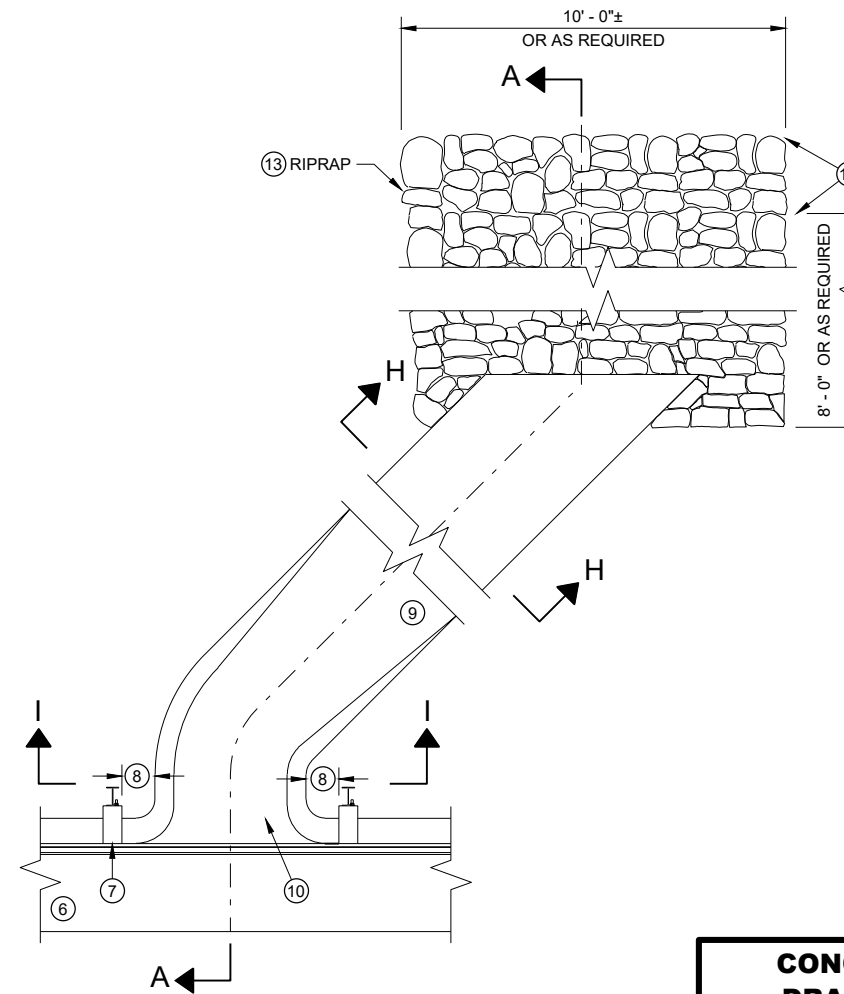

**PLAN VIEW SKEWED FLUME**

**GENERAL NOTES**

DETAILS OF CONSTRUCTION, MATERIALS AND WORKMANSHIP NOT SHOWN ON THIS DRAWING SHALL CONFORM TO THE PERTINENT REQUIREMENTS OF THE STANDARD SPECIFICATIONS AND THE APPLICABLE SPECIAL PROVISIONS.

ALL STEEL REINFORCEMENT SHALL BE EMBEDDED 2 INCHES CLEAR UNLESS OTHERWISE SHOWN OR NOTED.

- ① USE A JOINT SEALANT CONFORMING TO STANDARD SPECIFICATION 415.2.6.
- ② NO. 4 X 2'-0" TIE BARS SPACED AT 12" C-C TO BE PLACED BY BRIDGE CONTRACTOR OR DRILLED TIE BARS PLACED AS DIRECTED BY THE ENGINEER.
- ③ PAVED CONCRETE SHOULDER (SDD 13A03) OR CONCRETE DRAINAGE SLAB.
- ④ CONCRETE PAVEMENT APPROACH SLAB (SHOWN) OR STRUCTURE APPROACH SLAB AND CONCRETE PAVEMENT APPROACH SLAB. SEE SDD 13B02 AND STRUCTURE PLANS.
- ⑤ PAVED CONCRETE SHOULDER (SDD 13A03) OR ASPHALT SHOULDER.
- ⑥ CONCRETE CURB AND GUTTER 4-INCH SLOPED 36-INCH TYPE TBT OR TBTT. USE TYPE TBTT CURB WITH NO. 4 X 2'-0" TIE BARS SPACED AT 3'-0" C-C ONLY WHEN ADJACENT TO CONCRETE PAVEMENTS.

- ⑦ PLACE FLUME BEFORE MSG THRIE BEAM TRANSITION POST 1 (SEE SDD 14B45)
- ⑧ CENTER FLUME BETWEEN POSTS. 6-INCH MINIMUM SEPARATION FROM OUTSIDE EDGE OF FLUME TO POSTS.
- ⑨ MINIMUM REINFORCEMENT SHALL BE 4" X 4" - W3.0 X W3.0 OR NO. 3 BARS LONGITUDINAL AND TRANSVERSE SPACING 12" C -C.
- ⑩ SEE ROADWAY PLANS FOR FLUME LOCATION.
- ⑪ START CURB AND GUTTER TRANSITION OR END SECTION.
- ⑫ DEPRESS FLOW LINE (SEE DETAIL)
- ⑬ MEDIUM RIPRAP UNLESS OTHERWISE SPECIFIED.
- ⑭ LIMITS OF ADDITIONAL RIPRAP WHEN SPECIAL DITCH AS REQUIRED.
- ⑮ GEOTEXTILE TYPE HR.

**CONCRETE SURFACE DRAINS FLUME TYPE AT STRUCTURES**

STATE OF WISCONSIN  
DEPARTMENT OF TRANSPORTATION

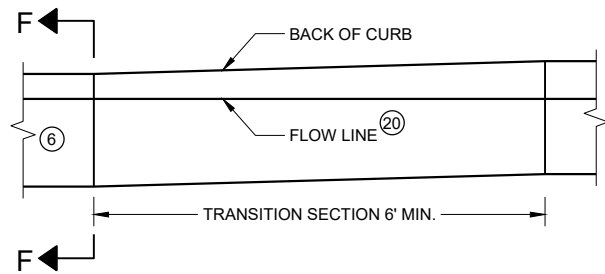

**CURB AND GUTTER TRANSITION SECTION  
CONCRETE CURB AND GUTTER 4-INCH SLOPED  
36 INCH TYPE TBT OR TBTT**

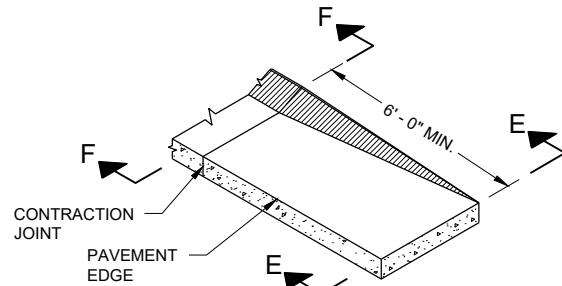

**CURB AND GUTTER END SECTION  
CONCRETE CURB AND GUTTER 4-INCH SLOPED  
36 INCH TYPE TBT OR TBTT**

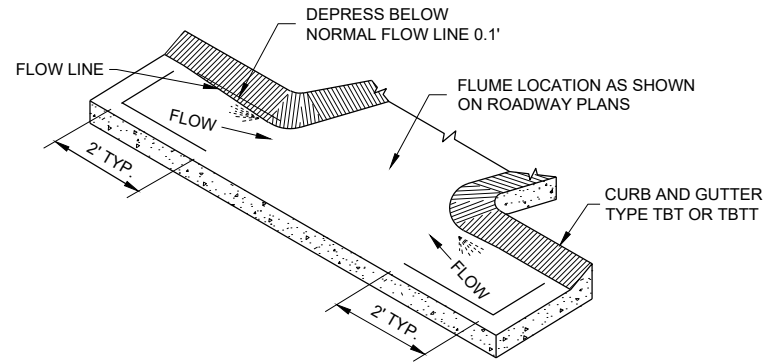

**CURB AND GUTTER FLOW LINE DEPRESSION  
AT FLUMES CONCRETE CURB AND GUTTER  
4-INCH SLOPED 36 INCH TYPE TBT OR TBTT**

**GENERAL NOTES**

DETAILS OF CONSTRUCTION, MATERIALS AND WORKMANSHIP NOT SHOWN ON THIS DRAWING SHALL CONFORM TO THE PERTINENT REQUIREMENTS OF THE STANDARD SPECIFICATIONS AND THE APPLICABLE SPECIAL PROVISIONS.

ALL STEEL REINFORCEMENT SHALL BE EMBEDDED 2 INCHES CLEAR UNLESS OTHERWISE SHOWN OR NOTED.

- ① USE A JOINT SEALANT CONFORMING TO STANDARD SPECIFICATION 415.2.6.
- ② NO. 4 X 2' - 0" TIE BARS SPACED AT 12" C-C TO BE PLACED BY BRIDGE CONTRACTOR OR DRILLED TIE BARS PLACED AS DIRECTED BY THE ENGINEER.
- ③ PAVED CONCRETE SHOULDER (SDD 13A03) OR CONCRETE DRAINAGE SLAB.
- ④ CONCRETE PAVEMENT APPROACH SLAB (SHOWN) OR STRUCTURE APPROACH SLAB AND CONCRETE PAVEMENT APPROACH SLAB. SEE SDD 13B02 AND STRUCTURE PLANS.
- ⑤ PAVED CONCRETE SHOULDER (SDD 13A03) OR ASPHALT SHOULDER.
- ⑥ CONCRETE CURB AND GUTTER 4-INCH SLOPED 36-INCH TYPE TBT OR TBTT. USE TYPE TBTT CURB WITH NO. 4 X 2' - 0" TIE BARS SPACED AT 3' - 0" C-C ONLY WHEN ADJACENT TO CONCRETE PAVEMENTS.
- ⑦ PLACE FLUME BEFORE MSG THRIE BEAM TRANSITION POST 1 (SEE SDD 14B45)
- ⑧ CENTER FLUME BETWEEN POSTS. 6-INCH MINIMUM SEPARATION FROM OUTSIDE EDGE OF FLUME TO POSTS.
- ⑨ MINIMUM REINFORCEMENT SHALL BE 4" X 4" - W3.0 X W3.0 OR NO. 3 BARS LONGITUDINAL AND TRANSVERSE SPACING 12" C-C.
- ⑩ SEE ROADWAY PLANS FOR FLUME LOCATION.
- ⑪ START CURB AND GUTTER TRANSITION OR END SECTION.
- ⑫ DEPRESS FLOW LINE (SEE DETAIL)
- ⑬ MEDIUM RIPRAP UNLESS OTHERWISE SPECIFIED.
- ⑭ LIMITS OF ADDITIONAL RIPRAP WHEN SPECIAL DITCH IS REQUIRED.
- ⑮ GEOTEXTILE TYPE HR.
- ⑯ MINIMUM REINFORCEMENT SHALL BE 6" X 6" - W4.0 X W4.0 OR NO. 3 BARS LONGITUDINAL AND TRANSVERSE SPACING 12" C-C.
- ⑰ MSG THRIE BEAM TRANSITION POST 1. SEE SDD 14B45 FOR ADDITIONAL CONSTRUCTION DETAILS AND ACCEPTABLE MATERIALS.
- ⑱ MAINTAIN WIDTH, THICKNESS AND CROSS SLOPE OF ADJACENT TYPE TBT OR TBTT CURB. SEE NOTE 6 FOR TIE BAR SPACING.
- ⑲ ALIGN FACE OF POST BLOCK WITH FLOW LINE.
- ⑳ MAINTAIN FLOW LINE AT EDGE OF PAVEMENT/FACE OF BEAM GUARD AS APPLICABLE.
- ㉑ DO NOT CONSTRUCT AN EXPANSION JOINT OR INSTALL DOWEL BARS WHEN ABUTTING HMA PAVEMENTS.

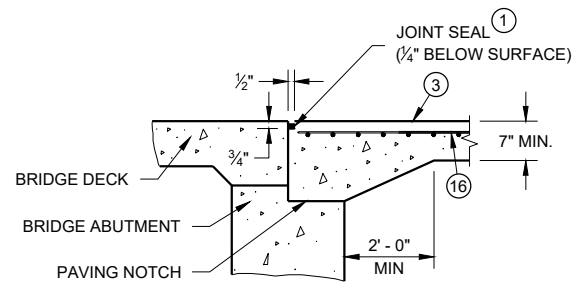

**SECTION B-B**

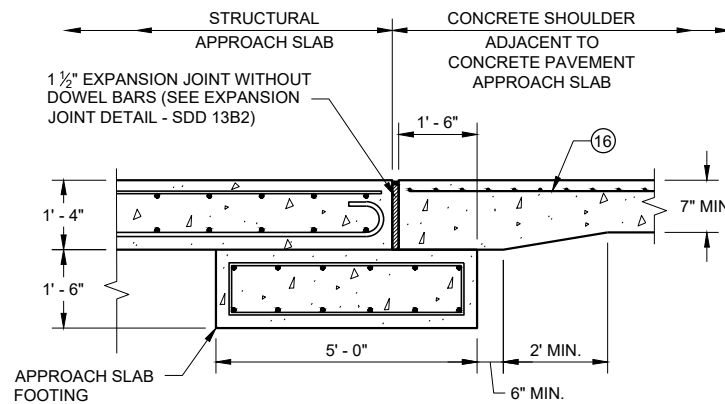

**SECTION C - C  
JOINT DETAIL FOR BRIDGE WITH STRUCTURAL  
APPROACH SLAB AND CONCRETE APPROACH SLAB**

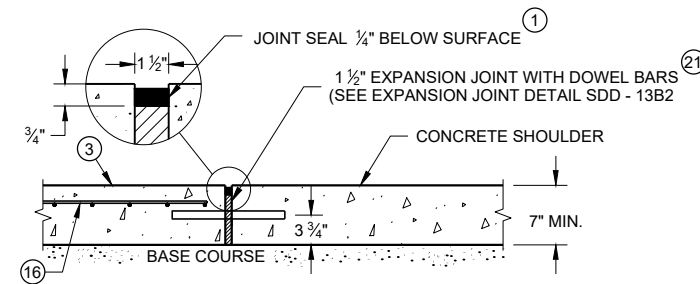

**SECTION C - C  
JOINT DETAIL FOR BRIDGE APPROACH  
WITH CONCRETE SHOULDERS**

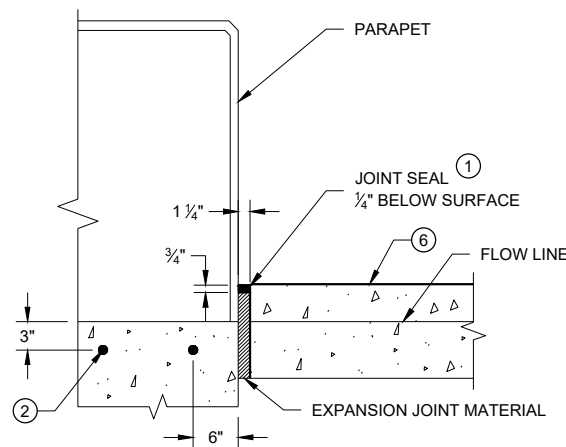

**SECTION D - D**

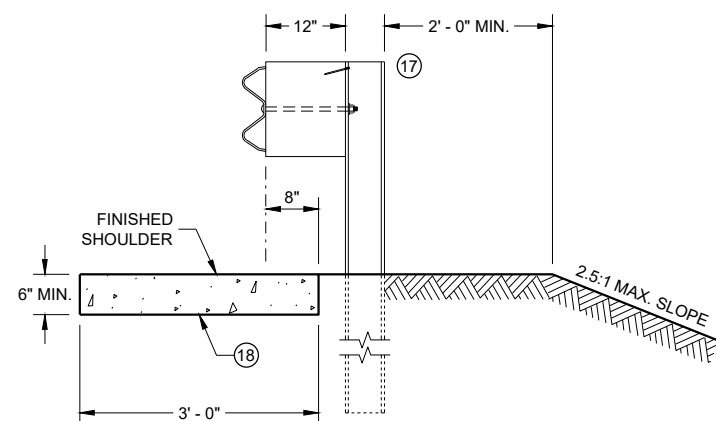

**SECTION E - E**

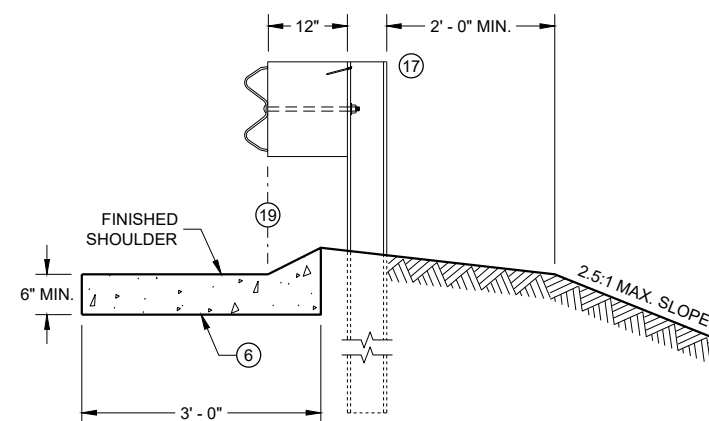

**SECTION F - F**

6

6

SDD08D02 - 08C

SDD08D02 - 08C

**CONCRETE SURFACE  
DRAINS FLUME TYPE  
AT STRUCTURES**

STATE OF WISCONSIN  
DEPARTMENT OF TRANSPORTATION

APPROVED  
May 2023 /S/ Rodney Taylor  
DATE ROADWAY STANDARDS DEVELOPMENT  
ENGINEER

FHWA

NOTE: TAPER CURB ENDS TO GUTTER IN 1' - 0"

### ASPHALTIC FLUME

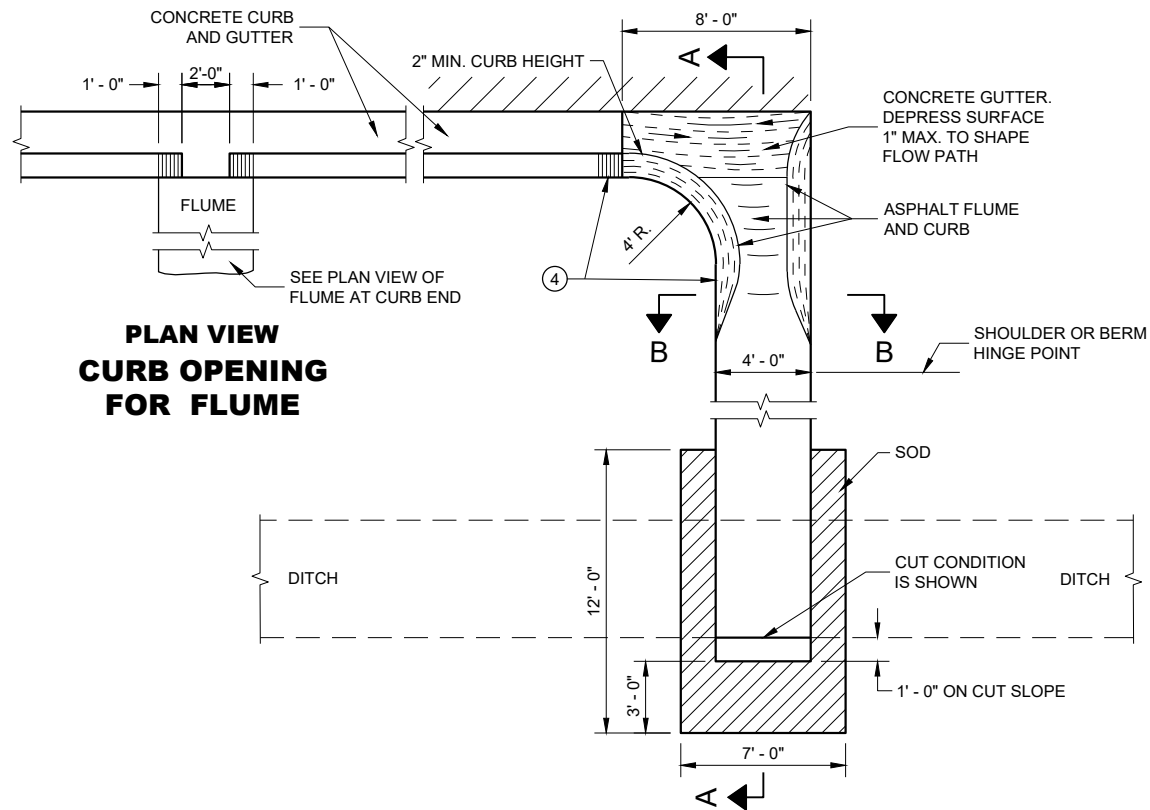

**PLAN VIEW  
CURB OPENING  
FOR FLUME**

**PLAN VIEW  
FLUME AT CURB END**

### GENERAL NOTES

DETAILS OF CONSTRUCTION, MATERIALS AND WORKMANSHIP NOT SHOWN ON THIS DRAWING SHALL CONFORM TO PERTINENT REQUIREMENTS OF THE STANDARD SPECIFICATIONS AND APPLICABLE SPECIAL PROVISIONS.

4" X 4" - W3.0 X W3.0 CONCRETE REINFORCEMENT SHALL BE IN ACCORDANCE WITH AASHTO SPECIFICATION M55.

- ① JOINTS SHALL BE 1/8" TO 1/4" WIDE BY 1 1/2" DEEP AND SPACED AT UNIFORM INTERVALS OF APPROXIMATELY 4 FEET.
- ② GEOTEXTILE TYPE "R" SHALL UNDERLAY THE FULL LENGTH AND WIDTH OF THE CONCRETE SURFACE DRAIN AND RIPRAP.
- ③ CONCRETE SURFACE DRAIN WITHOUT CURB AND GUTTER MAY BE USED ON BACKSLOPES WHEN SPECIFIED.
- ④ ANGLE OF FLUME IN RELATION TO BACK OF CURB TO BE CONSTRUCTED PER THE PLAN DETAILS OR AS DIRECTED BY THE ENGINEER. ANGLE OF FLUME MAY BE OTHER THAN 90 DEGREES AS SHOWN.

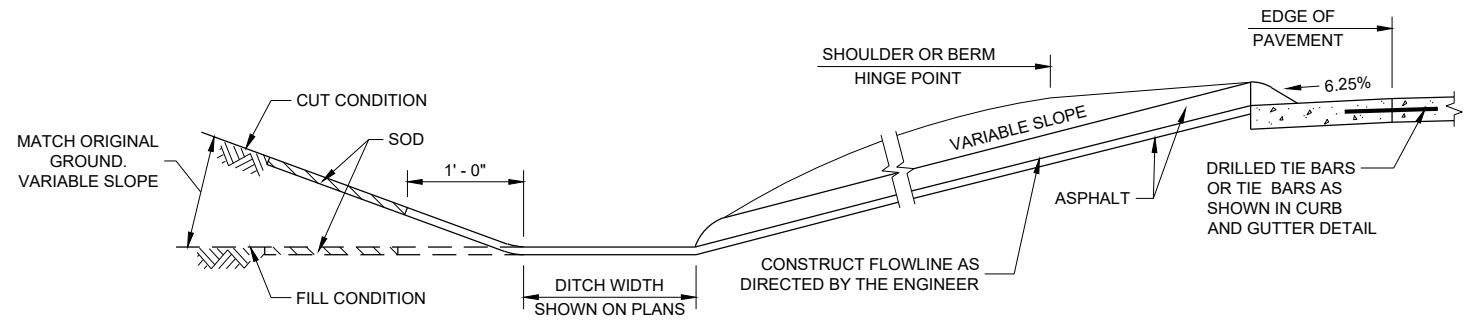

**SECTION A - A**

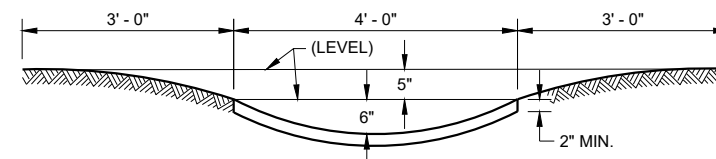

**SECTION B - B**

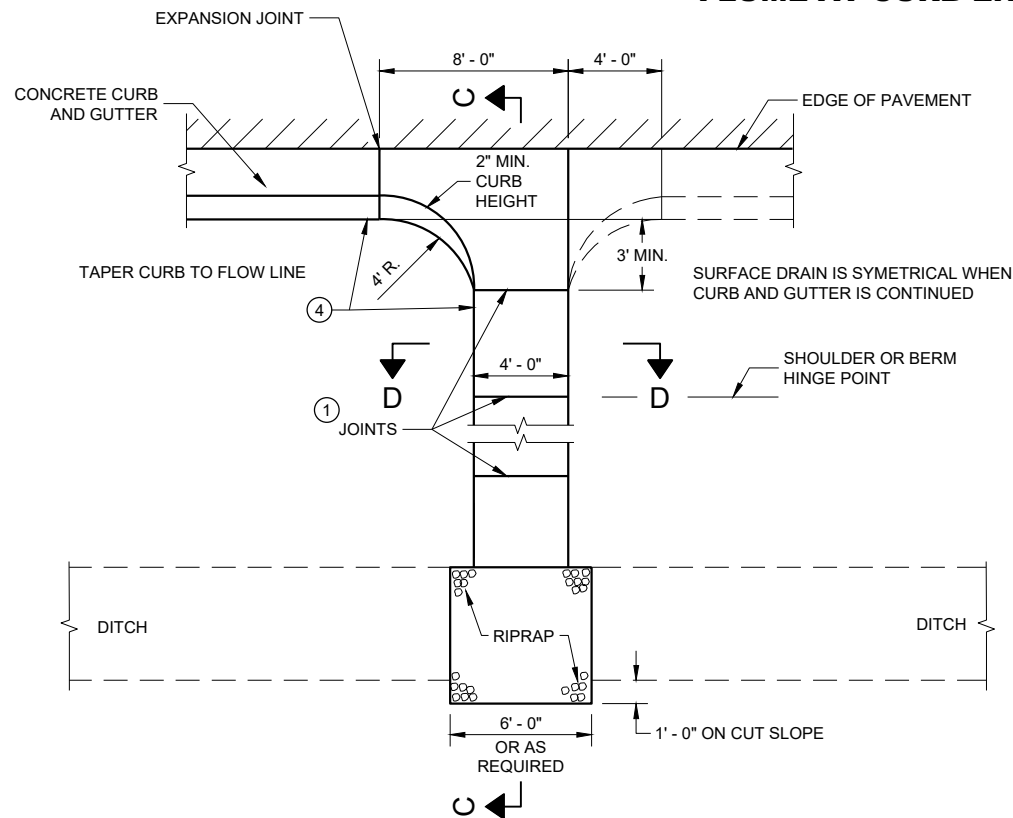

**PLAN VIEW  
CONCRETE SURFACE DRAIN**

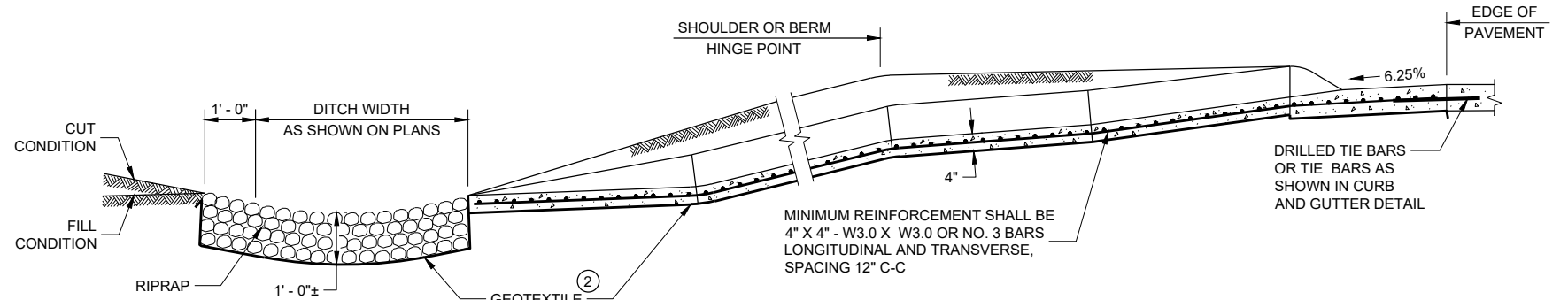

**SECTION C - C**

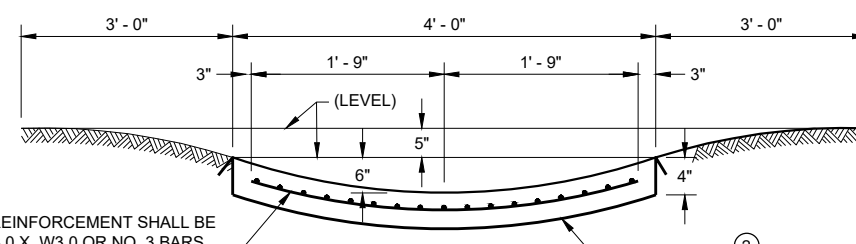

**SECTION D - D**

MINIMUM REINFORCEMENT SHALL BE 4" X 4" - W3.0 X W3.0 OR NO. 3 BARS LONGITUDINAL AND TRANSVERSE, SPACING 12" C-C

### CONCRETE SURFACE DRAINS AND ASPHALTIC FLUMES

STATE OF WISCONSIN  
DEPARTMENT OF TRANSPORTATION

APPROVED  
May 2023 /S/ Rodney Taylor  
DATE ROADWAY STANDARDS DEVELOPMENT  
ENGINEER

FHWA

	MIN.	MAX.
<b>A</b>	1.6"	2.4"
<b>B</b>	0.65"	1.5"
<b>C</b>	*	*
<b>D</b>	0.9"	1.4"

\* THE C DIMENSION IS 50% TO 65% OF THE D DIMENSION.

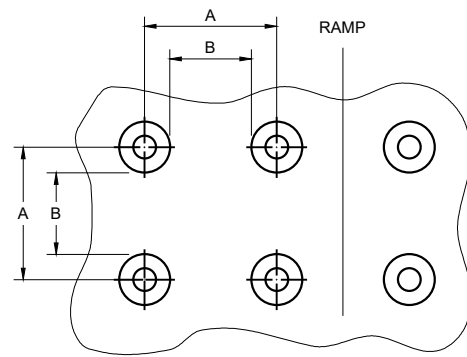

**PLAN VIEW**

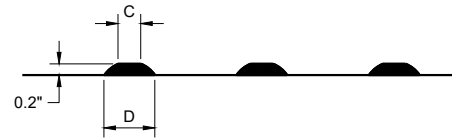

**ELEVATION VIEW**

**TRUNCATED DOMES  
DETECTABLE WARNING PATTERN DETAIL**

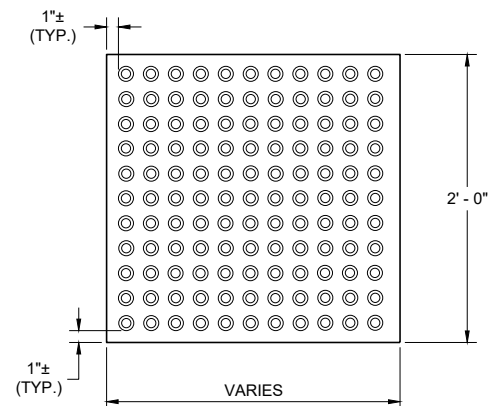

**RECTANGULAR  
PLATES**

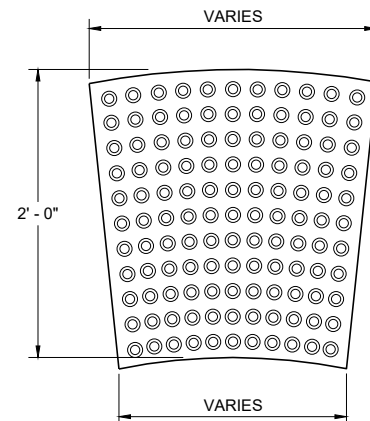

**RADIAL  
PLATES**

**PLAN VIEW  
DETECTABLE WARNING FIELDS (TYPICAL)**

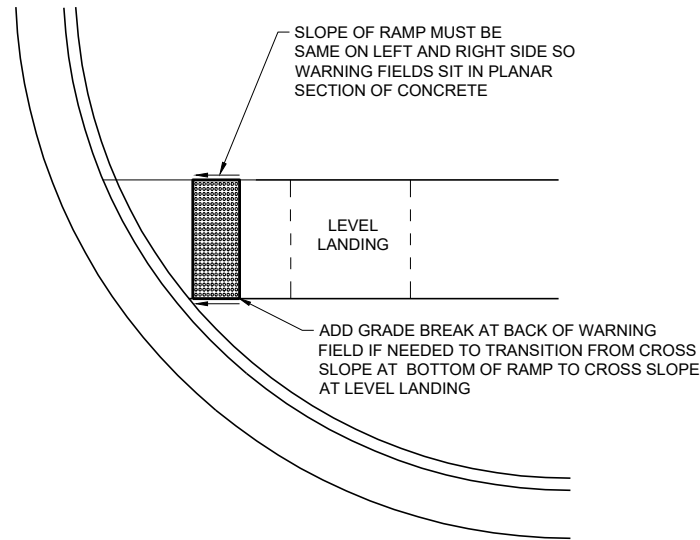

**DETECTABLE WARNING FIELD  
PLANAR INSTALLATION**

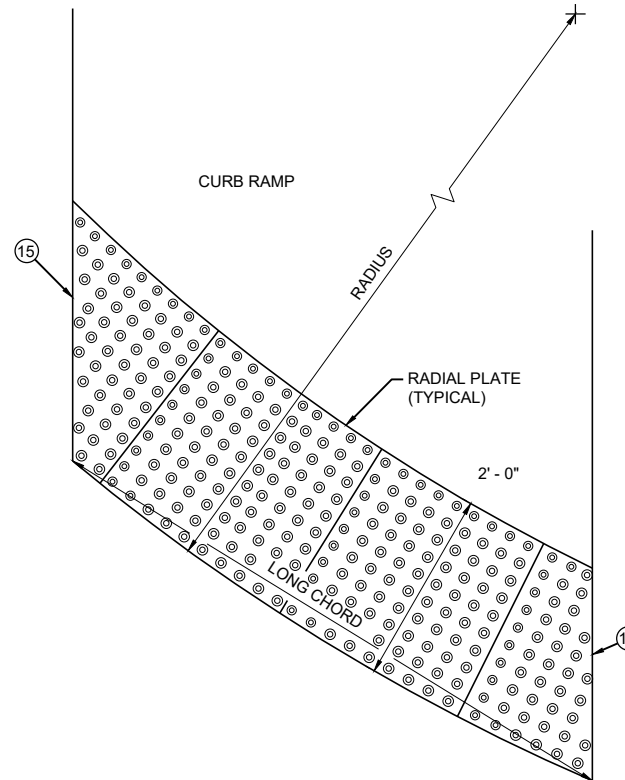

**PLAN VIEW  
RADIAL DETECTABLE  
WARNING FIELD ATTRIBUTES**

**GENERAL NOTES**

- DETECTABLE WARNING FIELDS THAT ARE INSTALLED AT A CURB RAMP SHALL BE FROM THE SAME MANUFACTURER.
- PLACE ALL DETECTABLE WARNING FIELD SYSTEMS IN ACCORDANCE TO THE MANUFACTURER'S RECOMMENDATION.
- FIELD CUTS AT INTERMEDIATE JOINTS WITHIN THE RADIAL DETECTABLE WARNING FIELD ARE PROHIBITED.
- DETERMINE FINAL RADIAL WARNING FIELD CONFIGURATION AND ITS INDIVIDUAL PLATE LOCATIONS. PERFORM PRE-LAYOUT PRIOR TO PLACEMENT IN PLASTIC CONCRETE. FOLLOW MANUFACTURER'S PRODUCT LIST AND INSTALLATION RECOMMENDATIONS.
- FOR RADIAL DETECTABLE WARNING FIELD APPLICATIONS WHERE STANDARD RADIAL PLATES ARE NOT AVAILABLE AT AN INTERSECTION CURB RADIUS, A COMBINATION OF SQUARE OR RECTANGULAR PLATES AND RADIAL PLATES MAY BE USED TO FORM RADIAL CONFIGURATION. RADIAL WEDGE PLATES IN COMBINATION WITH SQUARE PLATES ARE ALSO ACCEPTABLE. FOLLOW MANUFACTURER'S RECOMMENDATIONS.
- REFER TO CONTRACT AND STANDARD SPECIFICATIONS FOR FIELD CUTTING REQUIREMENTS.
- DO NOT EMBED IN CONCRETE ANY FIELD-CUT PLATES WITH CUT EDGES SHORTER THAN 6 INCHES. CONSULT WITH MANUFACTURER FOR RE-DRILLING AND ANCHORING REQUIREMENTS OF FIELD-CUT PLATES.
- (15) FIELD SAW CUTS ALONG RADIAL DETECTABLE WARNING PLATES WILL BE NECESSARY TO MATCH EACH CURB RAMP EDGE. AVOID CUTTING THROUGH DOMES WHENEVER POSSIBLE. MAKE FIELD CUTS TRUE TO LINE AND WITHIN 1/8" DEVIATION. SMOOTH EDGES OF FIELD CUT PLATES.

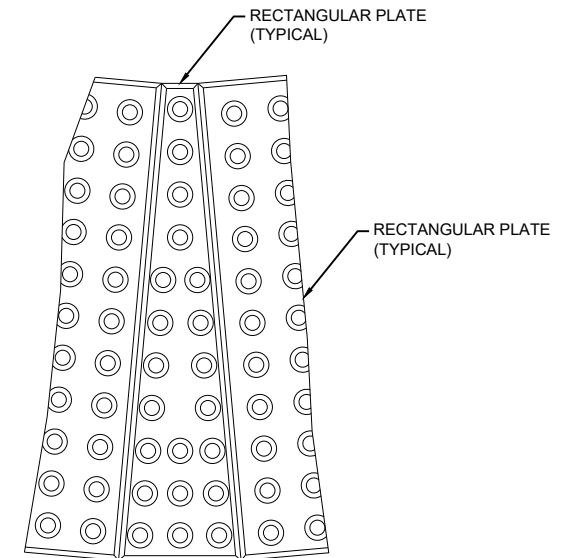

**PLAN VIEW  
RADIAL WEDGE PLATE  
CONNECTION DETAIL**

<b>CURB RAMPS RECTANGULAR AND RADIAL DETECTABLE WARNING PLATES</b>	
STATE OF WISCONSIN DEPARTMENT OF TRANSPORTATION	
APPROVED July 2023 DATE	/s/ Rodney Taylor ROADWAY STANDARDS DEVELOPMENT UNIT SUPERVISOR
FHWA	

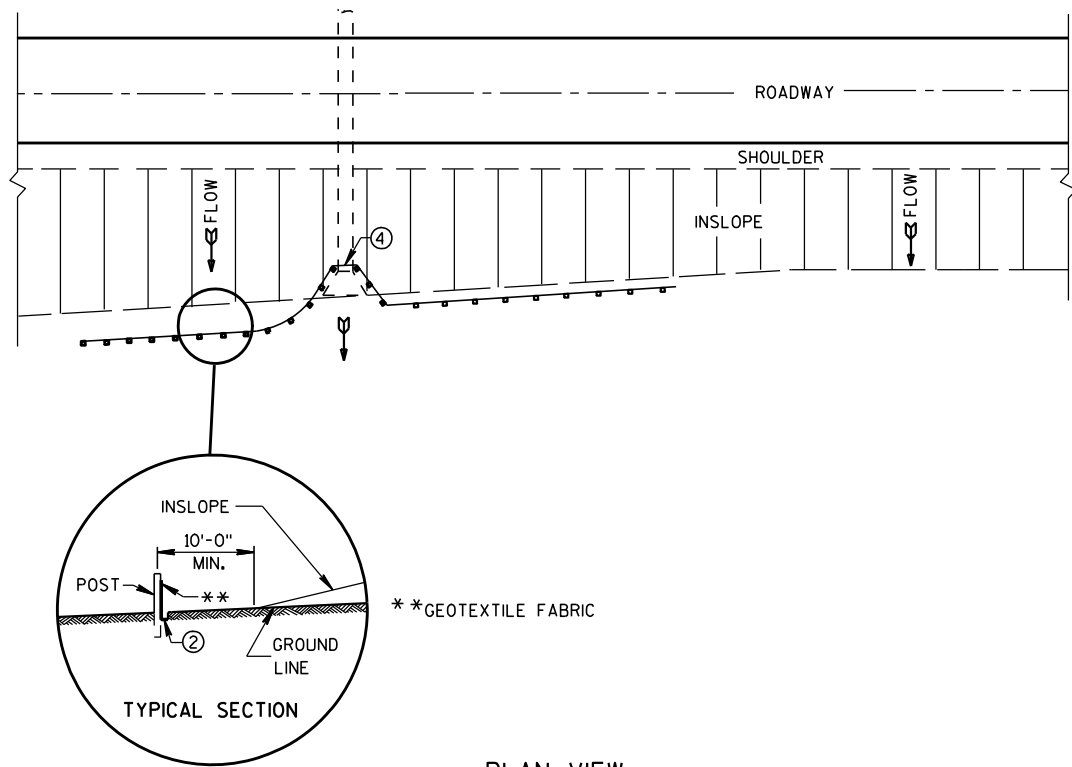

PLAN VIEW  
TYPICAL APPLICATION OF SILT FENCE

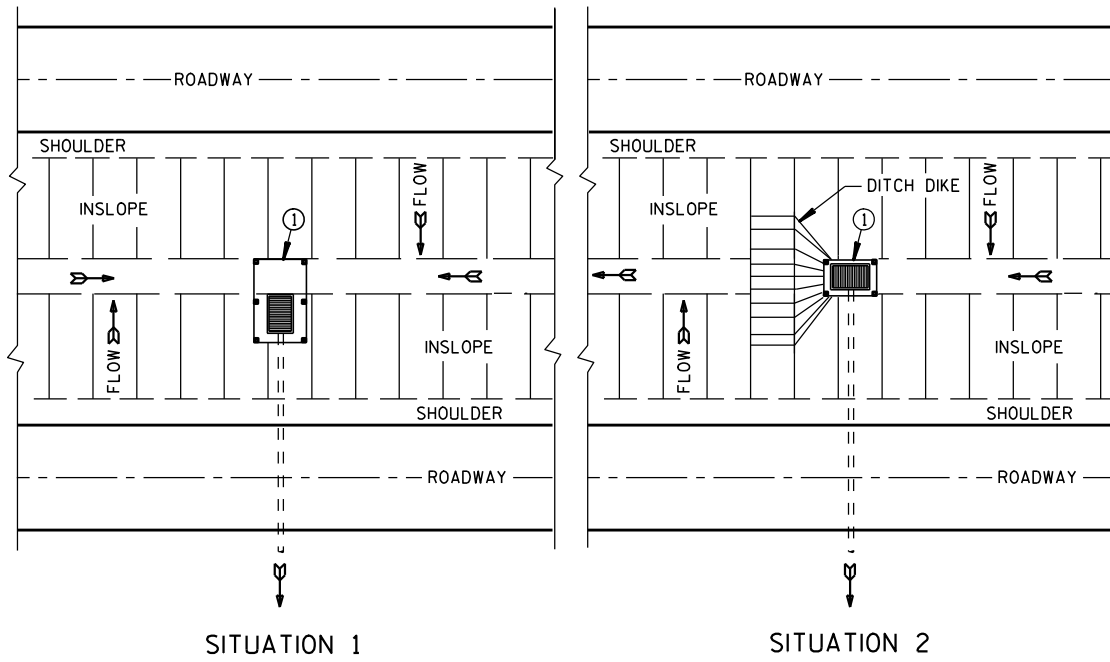

SITUATION 1 SITUATION 2  
PLAN VIEW  
SILT FENCE AT MEDIAN SURFACE DRAINS

**GENERAL NOTES**

DETAILS OF CONSTRUCTION NOT SHOWN ON THIS DRAWING SHALL CONFORM TO THE PERTINENT REQUIREMENTS OF THE STANDARD SPECIFICATIONS AND APPLICABLE SPECIAL PROVISIONS.

- ① HORIZONTAL BRACE REQUIRED WITH 2" X 4" WOODEN FRAME OR EQUIVALENT AT TOP OF POSTS.
- ② FOR MANUAL INSTALLATIONS THE TRENCH SHALL BE A MINIMUM OF 4" WIDE & 6" DEEP TO BURY AND ANCHOR THE GEOTEXTILE FABRIC. FOLD MATERIAL TO FIT TRENCH AND BACKFILL & COMPACT TRENCH WITH EXCAVATED SOIL.
- ③ WOOD POSTS SHALL BE A MINIMUM SIZE OF 1 1/8" X 1 1/8" OF OAK OR HICKORY.
- ④ SILT FENCE TO EXTEND ACROSS THE TOP OF THE PIPE.
- ⑤ CONSTRUCT SILT FENCE FROM A CONTINUOUS ROLL IF POSSIBLE BY CUTTING LENGTHS TO AVOID JOINTS. IF A JOINT IS NECESSARY USE ONE OF THE FOLLOWING TWO METHODS; A) OVERLAP THE END POSTS AND TWIST, OR ROTATE, AT LEAST 180 DEGREES, B) HOOK THE END OF EACH SILT FENCE LENGTH.

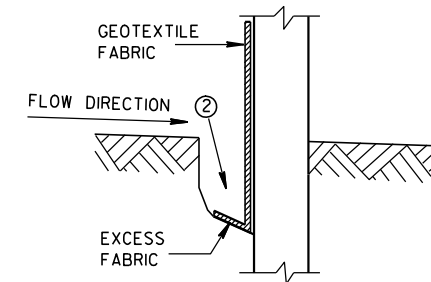

TRENCH DETAIL

NOTE: ADDITIONAL POST DEPTH OR TIE BACKS MAY BE REQUIRED IN UNSTABLE SOILS

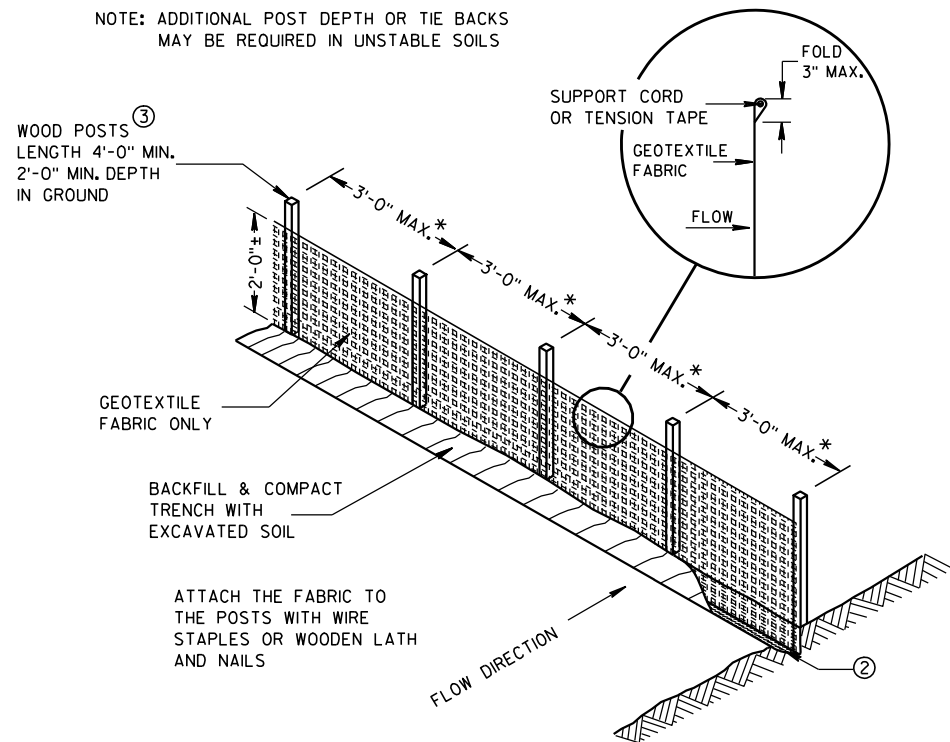

SILT FENCE

\* NOTE: 8'-0" POST SPACING ALLOWED IF A WOVEN GEOTEXTILE FABRIC IS USED.

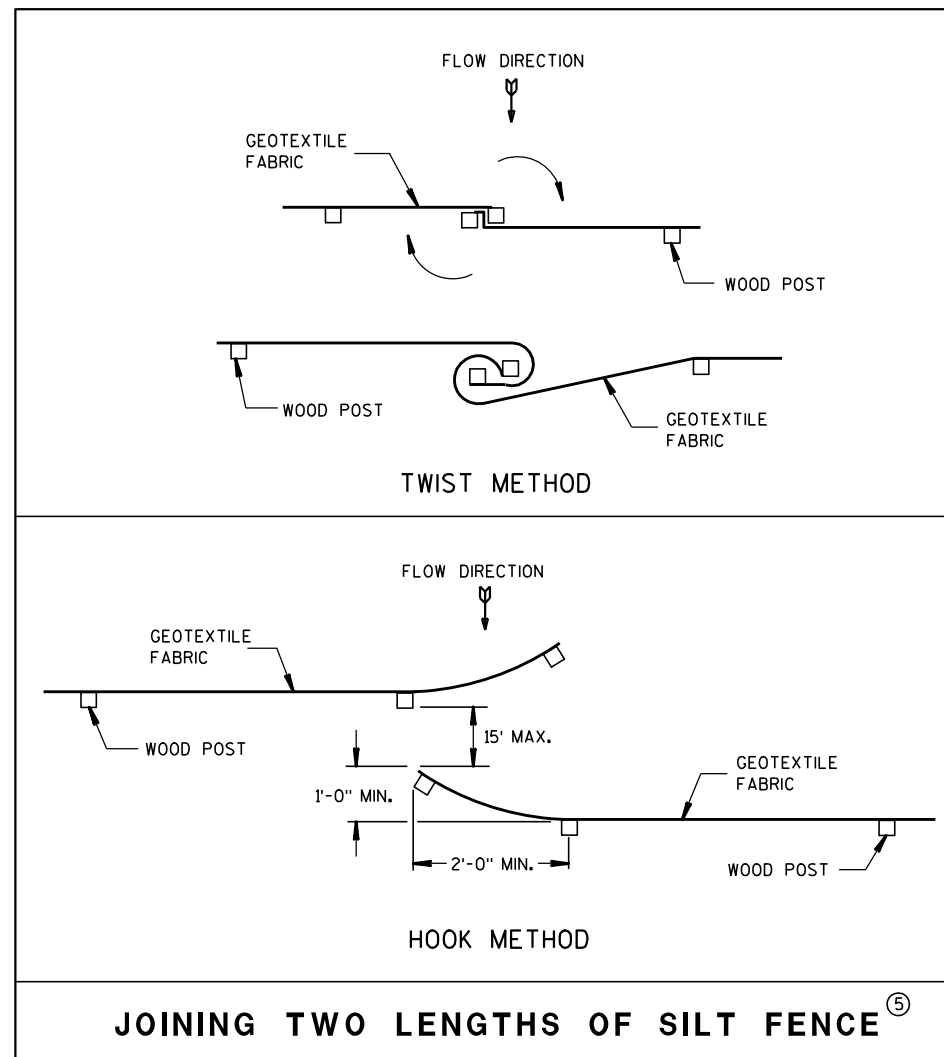

JOINING TWO LENGTHS OF SILT FENCE

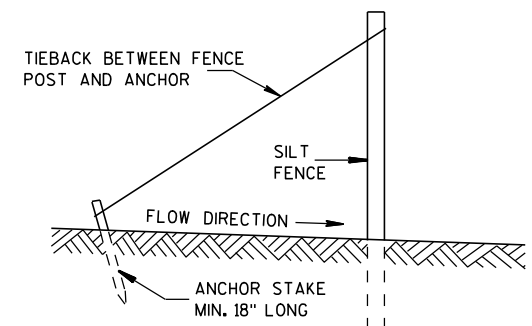

SILT FENCE TIE BACK  
(WHEN REQUIRED BY THE ENGINEER)

**SILT FENCE**

STATE OF WISCONSIN  
DEPARTMENT OF TRANSPORTATION

APPROVED

4-29-05

DATE

FHWA

/S/ Beth Canestra  
CHIEF ROADWAY DEVELOPMENT ENGINEER

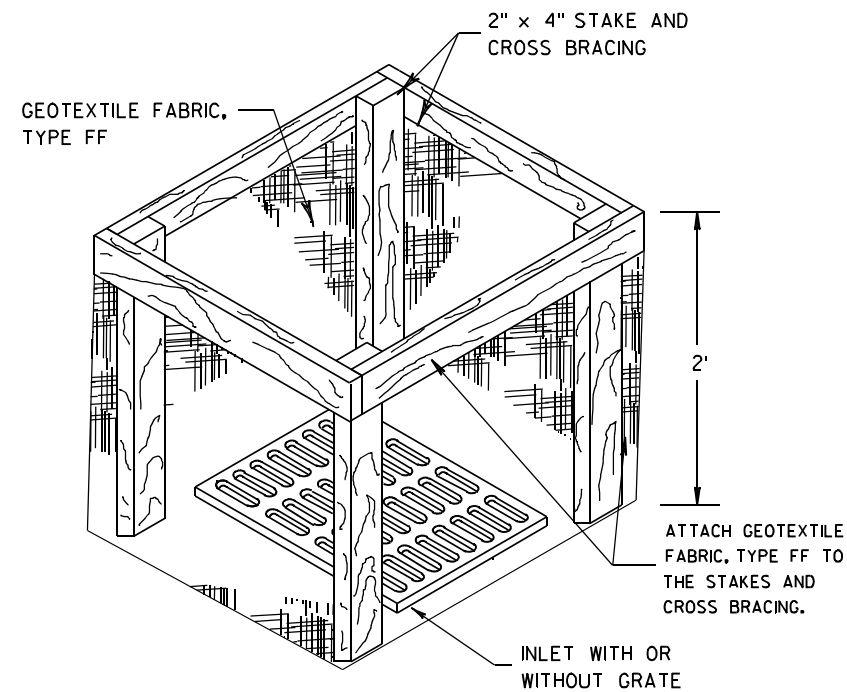
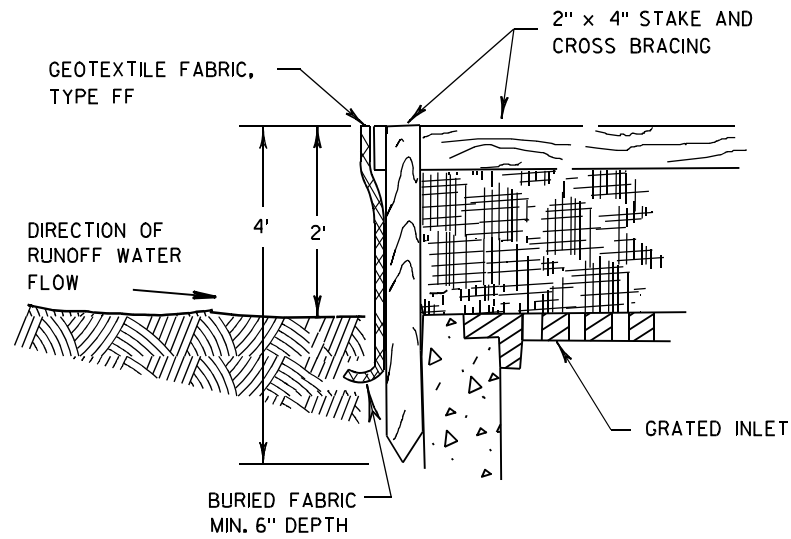

**INLET PROTECTION, TYPE A**

**GENERAL NOTES**

INLET PROTECTION DEVICES SHALL BE MAINTAINED OR REPLACED AT THE DIRECTION OF THE ENGINEER.

MANUFACTURED ALTERNATIVES APPROVED AND LISTED ON THE DEPARTMENT'S EROSION CONTROL PRODUCT ACCEPTABILITY LIST MAY BE SUBSTITUTED.

WHEN REMOVING OR MAINTAINING INLET PROTECTION, CARE SHALL BE TAKEN SO THAT THE SEDIMENT TRAPPED ON THE GEOTEXTILE FABRIC DOES NOT FALL INTO THE INLET. ANY MATERIAL FALLING INTO THE INLET SHALL BE REMOVED IMMEDIATELY.

- ① FINISHED SIZE, INCLUDING FLAP POCKETS WHERE REQUIRED, SHALL EXTEND A MINIMUM OF 10" AROUND THE PERIMETER TO FACILITATE MAINTENANCE OR REMOVAL.
- ② FOR INLET PROTECTION, TYPE C (WITH CURB BOX), AN ADDITIONAL 18" OF FABRIC IS WRAPPED AROUND THE WOOD AND SECURED WITH STAPLES. THE WOOD SHALL NOT BLOCK THE ENTIRE HEIGHT OF THE CURB BOX OPENING.
- ③ FLAP POCKETS SHALL BE LARGE ENOUGH TO ACCEPT WOOD 2X4.

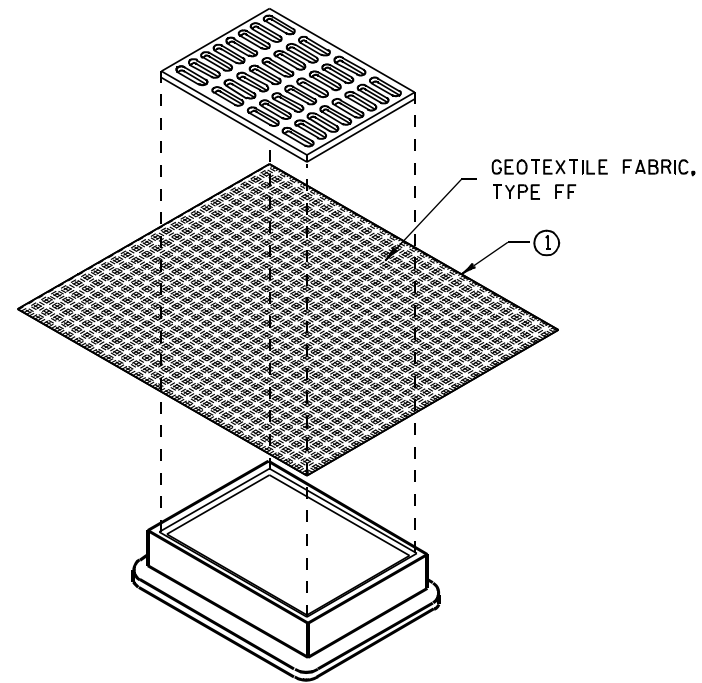

**INLET PROTECTION, TYPE B  
(WITHOUT CURB BOX)**

(CAN BE INSTALLED IN ANY INLET WITHOUT A CURB BOX)

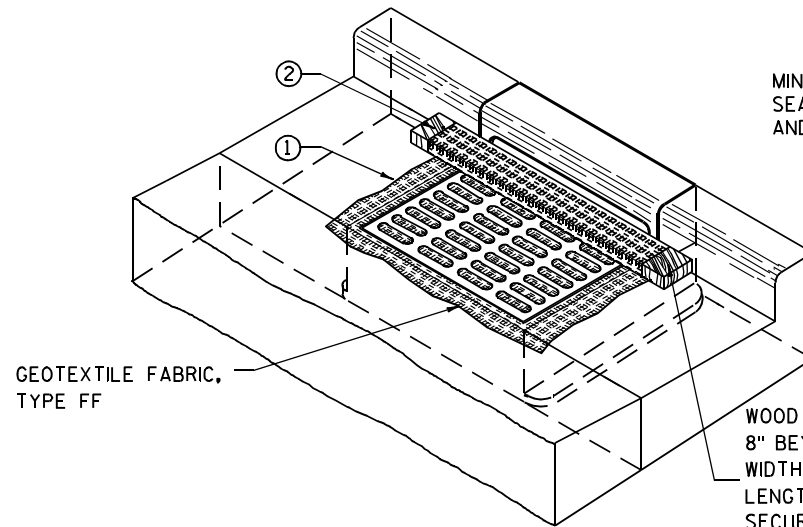

**INLET PROTECTION, TYPE C (WITH CURB BOX)**

**INSTALLATION NOTES**

**TYPE B & C**

TRIM EXCESS FABRIC IN THE FLOW LINE TO WITHIN 3" OF THE GRATE.

THE CONTRACTOR SHALL DEMONSTRATE A METHOD OF MAINTENANCE, USING A SEWN FLAP, HAND HOLDS OR OTHER METHOD TO PREVENT ACCUMULATED SEDIMENT FROM ENTERING THE INLET.

**TYPE D**

DO NOT INSTALL INLET PROTECTION TYPE D IN INLETS SHALLOWER THAN 30", MEASURED FROM THE BOTTOM OF THE INLET TO THE TOP OF THE GRATE.

TRIM EXCESS FABRIC IN THE FLOW LINE TO WITHIN 3" OF THE GRATE.

THE INSTALLED BAG SHALL HAVE A MINIMUM SIDE CLEARANCE, BETWEEN THE INLET WALLS AND THE BAG, MEASURED AT THE BOTTOM OF THE OVERFLOW HOLES, OF 3". WHERE NECESSARY THE CONTRACTOR SHALL CINCH THE BAG, USING PLASTIC ZIP TIES, TO ACHIEVE THE 3" CLEARANCE. THE TIES SHALL BE PLACED AT A MAXIMUM OF 4" FROM THE BOTTOM OF THE BAG.

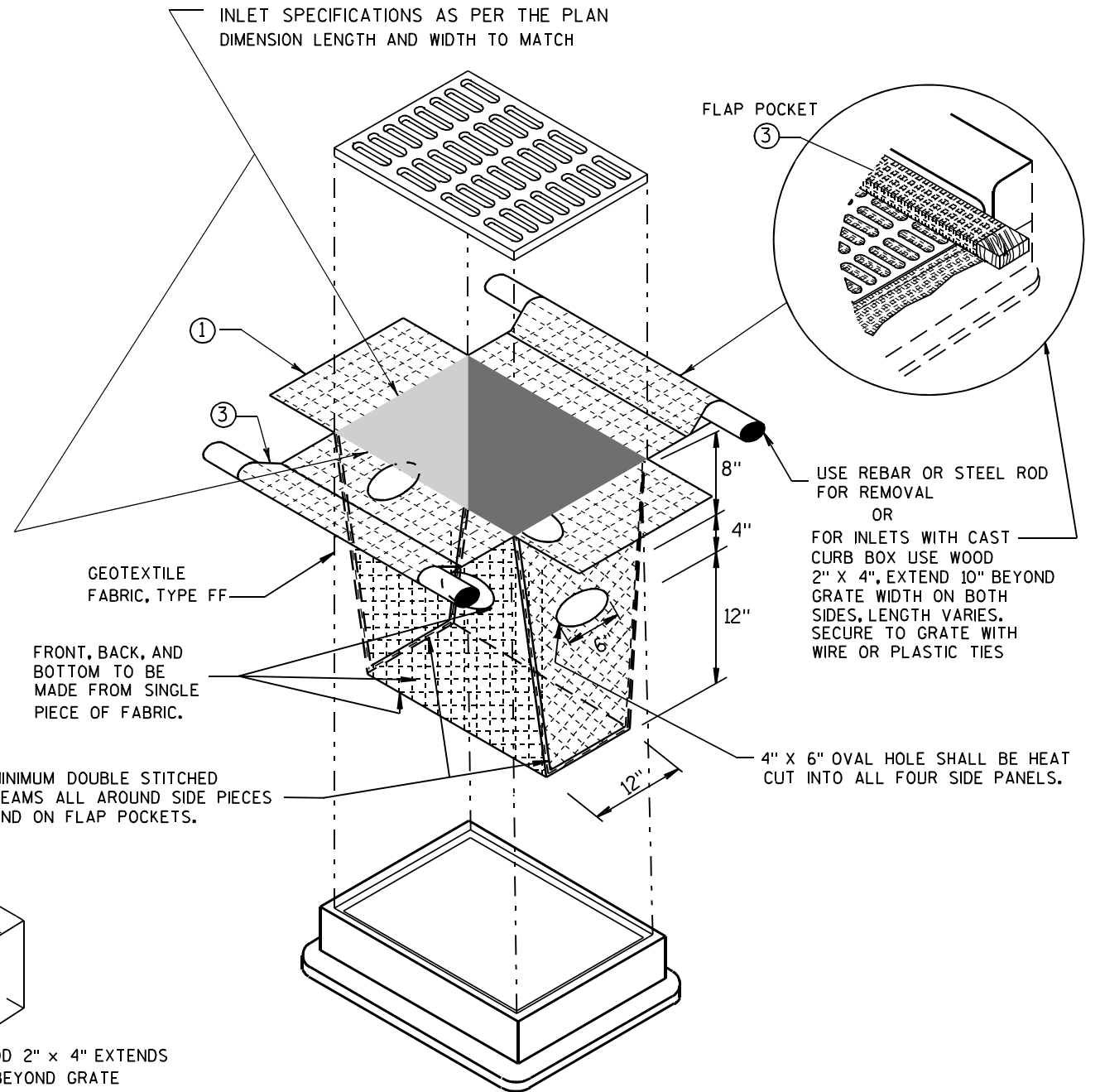

**INLET PROTECTION, TYPE D**

(CAN BE INSTALLED IN ANY INLET TYPE WITH OR WITHOUT A CURB BOX AS PER NOTE ②)

<b>INLET PROTECTION TYPE A, B, C, AND D</b>	
STATE OF WISCONSIN DEPARTMENT OF TRANSPORTATION	
APPROVED 10/16/02 DATE	/S/ Beth Connestra CHIEF ROADWAY DEVELOPMENT ENGINEER
FHWA	

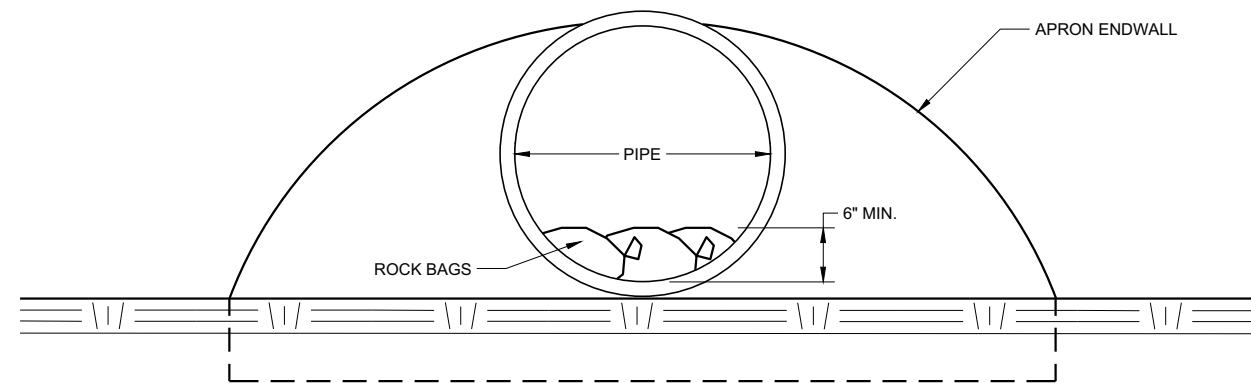

**END VIEW**

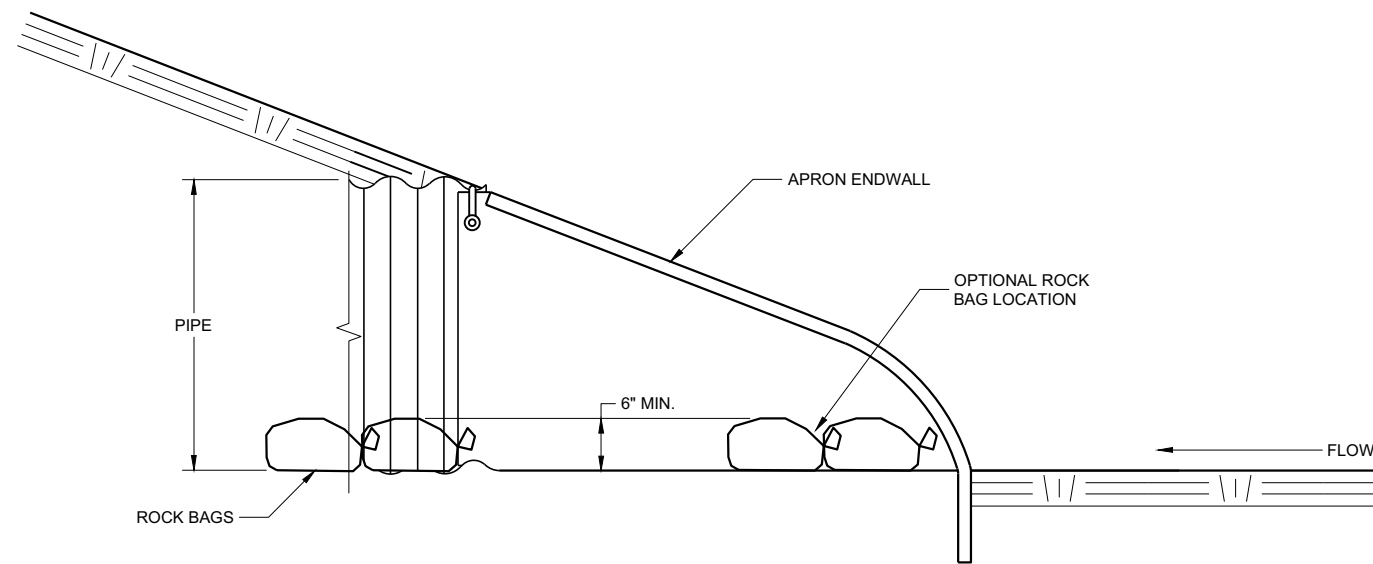

**SIDE VIEW**

**CULVERT PIPE CHECK**  
(INSTALL ON INLET END ONLY)

6

6

SDD 08E15 - 01

SDD 08E15 - 01

<b>CULVERT PIPE CHECK</b>	
STATE OF WISCONSIN DEPARTMENT OF TRANSPORTATION	
APPROVED May 2019 DATE	/S/ Daniel Schave EROSION CONTROL ENGINEER
<small>FHWA</small>	



METAL APRON ENDWALLS											
PIPE DIA. (IN.)	MIN. THICK. (Inches)		DIMENSIONS (Inches)							APPROX. SLOPE	BODY
	STEEL	ALUM.	A (±1")	B (MAX.)	H (±1")	L (±1 1/2")	L1	L2	W (±2")		
12	.064	.060	6	6	6	21	12	17 1/2	24	2 1/2 to 1	1 Pc.
15	.064	.060	7	8	6	26	14	21 3/4	30	2 1/2 to 1	1 Pc.
18	.064	.060	8	10	6	31	15	28 1/4	36	2 1/2 to 1	1 Pc.
21	.064	.060	9	12	6	36	18	29 5/8	42	2 1/2 to 1	1 Pc.
24	.064	.075	10	13	6	41	18	37 1/4	48	2 1/2 to 1	1 Pc.
30	.079	.075	12	16	8	51	18	52 1/4	60	2 1/2 to 1	1 Pc.
36	.079	.105	14	19	9	60	24	59 3/4	72	2 1/2 to 1	2 Pc.
42	.109	.105	16	22	11	69	24	75 5/8	84	2 1/2 to 1	2 Pc.
48	.109	.105	18	27	12	78	24	81	90	2 1/4 to 1	3 Pc.
54	.109	.105	18	30	12	84	30	85 1/2	102	2 1/4 to 1	3 Pc.
60	.109x	.105x	18	33	12	87	—	—	114	2 to 1	3 Pc.
66	.109x	.105x	18	36	12	87	—	—	120	2 to 1	3 Pc.
72	.109x	.105x	18	39	12	87	—	—	126	2 to 1	3 Pc.
78	.109x	.105x	18	42	12	87	—	—	132	1 1/2 to 1	3 Pc.
84	.109x	.105x	18	45	12	87	—	—	138	1 1/2 to 1	3 Pc.
90	.109x	.105x	18	37	12	87	—	—	144	1 1/2 to 1	3 Pc.
96	.109x	.105x	18	35	12	87	—	—	150	1 1/2 to 1	3 Pc.

\* EXCEPT CENTER PANEL SEE GENERAL NOTES

REINFORCED CONCRETE APRON ENDWALLS									
PIPE DIA. (IN.)	DIMENSIONS (Inches)							APPROX. SLOPE	
	T	A	B	C	D	E	G		
12	2	4	24	48 1/8	72 1/8	24	2	3 to 1	
15	2 1/4	6	27	46	73	30	2 1/4	3 to 1	
18	2 1/2	9	27	46	73	36	2 1/2	3 to 1	
21	2 3/4	9	36	37 1/2	73 1/2	42	2 3/4	3 to 1	
24	3	9 1/2	43 1/2	30	73 1/2	48	3	3 to 1	
27	3 1/4	10 1/2	49 1/2	24	73 1/2	54	3 1/4	3 to 1	
30	3 1/2	12	54	19 3/4	73 1/2	60	3 1/2	3 to 1	
36	4	15	63	34 3/4	97 3/4	72	4	3 to 1	
42	4 1/2	21	63	35	98	78	4 1/2	3 to 1	
48	5	24	72	26	98	84	5	3 to 1	
54	5 1/2	27	65	33 1/4-35	98 1/4-100	90	5 1/2	2 1/2 to 1	
60	6	30-35	60	39	99	96	5	2 to 1	
66	6 1/2	30-35	72-78	21-27	99	102	5 1/2	2 to 1	
72	7	30-35	78	21	99	108	6	2 to 1	
78	7 1/2	30-35	78	21	99	114	6 1/2	2 to 1	
84	8	36	90 1/2	21	111 1/2	120	6 1/2	1 1/2 to 1	
90	8 1/2	41	87 1/2	24	111 1/2	132	6 1/2	1 1/2 to 1	

\* MINIMUM  
\*\* MAXIMUM

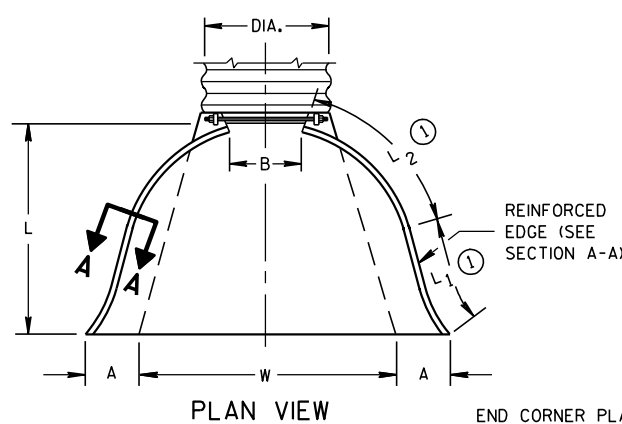

END CORNER PLATES MAY BE FASTENED TO APRON PROPER BY BOLTS, RIVETS, OR RESISTANCE SPOT WELDS WHICH WILL HOLD THE SURFACES TIGHTLY TOGETHER

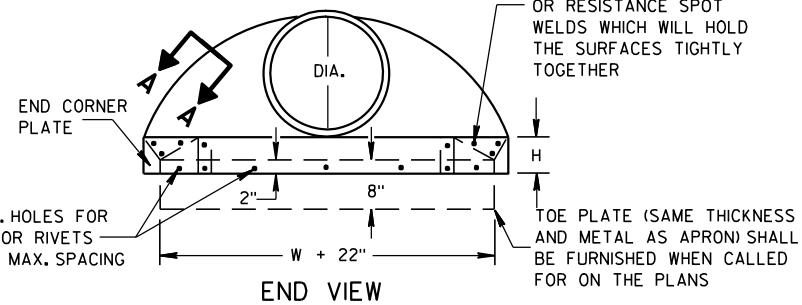

SIDE ELEVATION  
METAL ENDWALLS

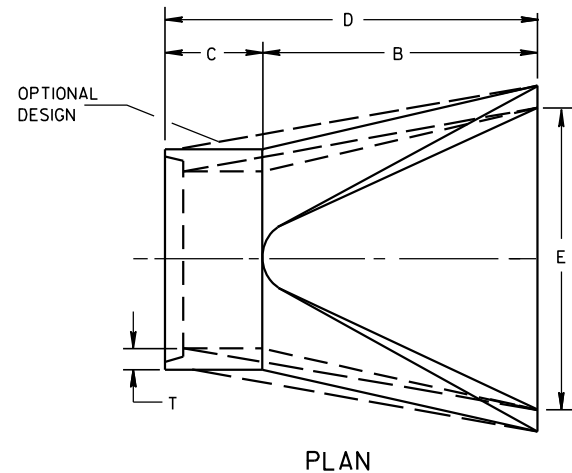

PLAN

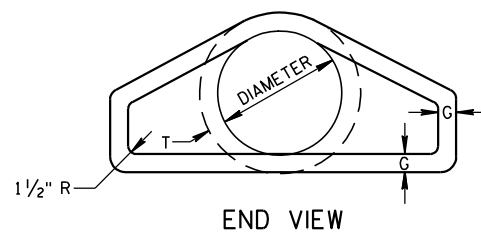

END VIEW

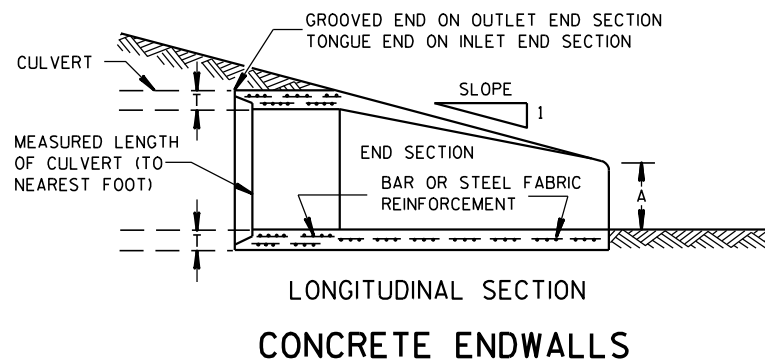

LONGITUDINAL SECTION  
CONCRETE ENDWALLS

1" WIDE, 12 GA. (0.109" THICK) GALVANIZED STRAP WITH STANDARD 6" X 1/2" BAND BOLT AND NUT

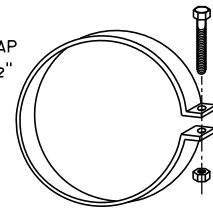

ALTERNATE FOR TYPE 1 CONNECTION  
END SECTION CONNECTOR STRAP

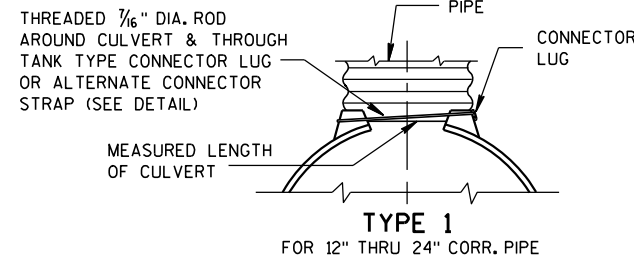

TYPE 1  
FOR 12" THRU 24" CORR. PIPE

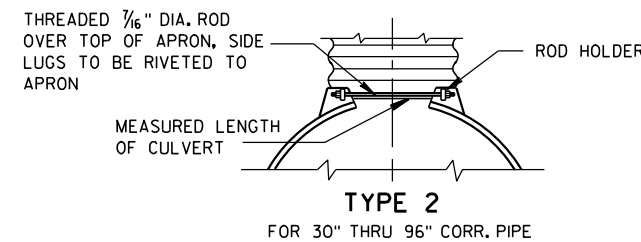

TYPE 2  
FOR 30" THRU 96" CORR. PIPE

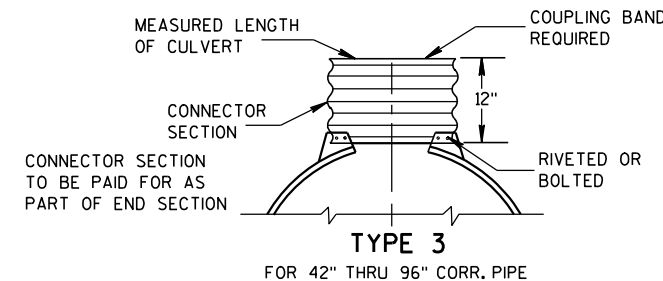

TYPE 3  
FOR 42" THRU 96" CORR. PIPE

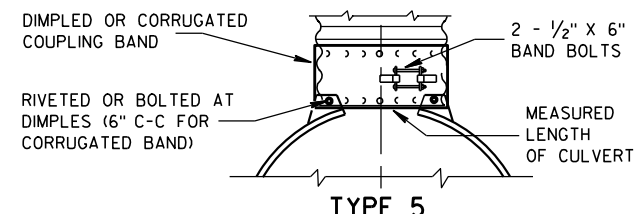

ALTERNATE FOR:  
ALL SIZES CORRUGATED CIRCULAR PIPE

NOTE: DIMPLED BAND FITS OVER OUTSIDE OF ENDWALL, AND CORRUGATED BAND FITS INSIDE ENDWALL. DIMPLED BAND MAY BE USED WITH HELICALLY CORRUGATED PIPE.

FOR CIRCUMFERENTIALLY CORRUGATED PIPE USE ENDWALL CONNECTION DETAILS 1, 2, 3 OR 5 AS APPLICABLE.

FOR HELICALLY CORRUGATED PIPE USE ENDWALL CONNECTION DETAILS 1, 2 OR 5.

FOR HELICALLY CORRUGATED PIPES WITH TWO CIRCUMFERENTIAL CORRUGATIONS AT EACH END USE ENDWALL CONNECTION DETAILS 1, 2 OR 3.

CONNECTION DETAILS

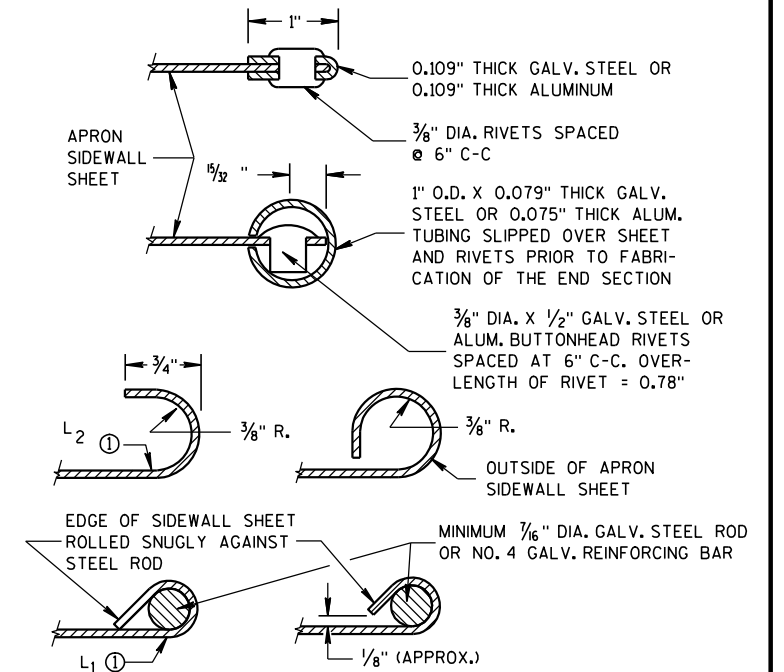

SECTION A-A

GENERAL NOTES

DETAILS OF CONSTRUCTION, MATERIALS AND WORKMANSHIP NOT SHOWN ON THIS DRAWING SHALL CONFORM TO THE PERTINENT REQUIREMENTS OF THE STANDARD SPECIFICATIONS AND THE APPLICABLE SPECIAL PROVISIONS.

CONCRETE CULVERT ENDWALLS MAY NOT BE USED WITH GALVANIZED STEEL OR ALUMINUM CULVERT PIPE OR VICE VERSA. GALVANIZED STEEL OR ALUMINUM ENDWALLS SHALL NORMALLY BE INSTALLED ON CULVERT PIPE OF THE SAME METAL.

ALL THREE PIECE STEEL APRON ENDWALLS FOR 60" DIAMETER PIPE AND LARGER SHALL HAVE 0.109" SIDES AND 0.138" CENTER PANELS. ALL THREE PIECE ALUMINUM APRON ENDWALLS FOR 60" DIAMETER PIPE AND LARGER SHALL HAVE 0.105" SIDES AND 0.134" CENTER PANELS. THE WIDTH OF CENTER PANELS SHALL BE GREATER THAN 20 PERCENT OF THE PIPE PERIMETER.

LAP SEAMS SHALL BE TIGHTLY JOINED BY GALVANIZED RIVETS OR BOLTS FOR STEEL UNITS AND ALUMINUM RIVETS AND BOLTS FOR ALUMINUM UNITS. FOR THE 60" THROUGH 96" DIAMETER APRON ENDWALL SIZES, THE REINFORCED EDGES AND CENTER PANEL SEAMS SHALL BE FURTHER REINFORCED WITH GALVANIZED STEEL OR ALUMINUM STIFFENER ANGLES. THE ANGLES SHALL BE ATTACHED BY GALVANIZED NUTS AND BOLTS FOR STEEL UNITS AND ALUMINUM NUTS AND BOLTS FOR ALUMINUM UNITS.

WHERE TWO OR MORE PIPES WITH APRON ENDWALLS ARE LAID ADJACENT TO EACH OTHER, THEY SHALL BE SEPARATED BY A DISTANCE SUFFICIENT TO PROVIDE A MINIMUM CLEARANCE OF 6 INCHES BETWEEN APRON ENDWALLS.

① FOR PIPE SIZES UP TO 60" DIAMETER, A 180° ROLLED EDGE MAY BE USED INSTEAD OF STEEL ROD REINFORCEMENT. SEE SECTION A-A.

APRON ENDWALLS FOR  
CULVERT PIPE

STATE OF WISCONSIN  
DEPARTMENT OF TRANSPORTATION

APPROVED  
11/30/94 DATE /S/ Rory L. Rhinesmith  
DATE CHIEF ROADWAY DEVELOPMENT ENGINEER  
FHWA

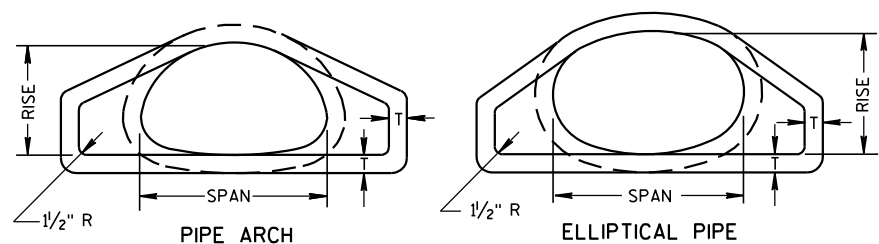

END VIEW

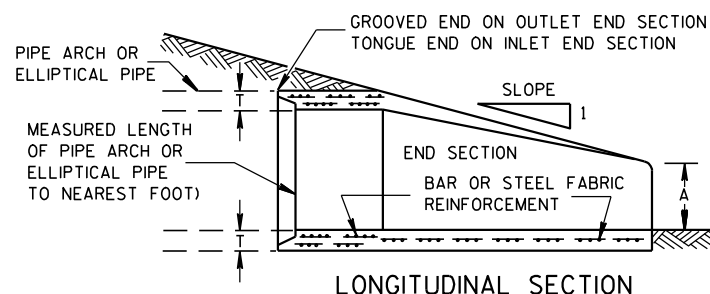

LONGITUDINAL SECTION

CONCRETE ENDWALLS

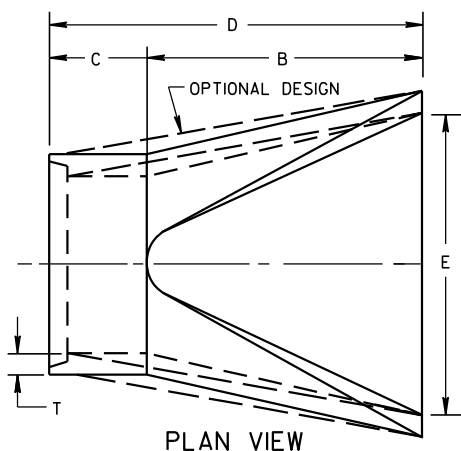

PLAN VIEW

2- 2/3" X 1/2" CORRUGATIONS													
EQUIV. DIA. (Inches)	(Inches)		MIN. THICK. (Inches)		DIMENSIONS (Inches)							APPROX. SLOPE	BODY
	SPAN	RISE	STEEL	ALUM.	A (±1")	B (MAX.)	H (±1")	L (±1 1/2")	L1 (⊙)	L2 (⊙)	W (±2")		
15	17	13	.064	.060	7	9	6	19	14	16	30	2 1/2 to 1	1 Pc.
18	21	15	.064	.060	7	10	6	23	14	19 3/8	36	2 1/2 to 1	1 Pc.
21	24	18	.064	.060	8	12	6	28	18	21 3/4	42	2 1/2 to 1	1 Pc.
24	28	20	.064	.060	9	14	6	32	18	27 1/2	48	2 1/2 to 1	1 Pc.
30	35	24	.079	.075	10	16	6	39	18	37 5/8	60	2 1/2 to 1	1 Pc.
36	42	29	.079	.075	12	18	8	46	24	45 3/8	75	2 1/2 to 1	1 Pc.
42	49	33	.109	.105	13	21	9	53	24	54 3/4	85	2 1/2 to 1	2 Pc.
48	57	38	.109	.105	18	26	12	63	24	68	90	2 1/2 to 1	3 Pc.
54	64	43	.109	.105	18	30	12	70	24	72 3/4	102	2 1/4 to 1	3 Pc.
60	71	47	.109*	.105*	18	33	12	77	30	82 1/4	114	2 1/4 to 1	3 Pc.
66	77	52	.109*	.105*	18	36	12	77	—	—	126	2 to 1	3 Pc.
72	83	57	.109*	.105*	18	39	12	77	—	—	138	2 to 1	3 Pc.

3" X 1" CORRUGATIONS													
EQUIV. DIA. (Inches)	(Inches)		MIN. THICK. (Inches)		DIMENSIONS (Inches)							APPROX. SLOPE	BODY
	SPAN	RISE	STEEL	ALUM.	A (±1")	B (MAX.)	H (±1")	L (±1 1/2")	L1 (⊙)	L2 (⊙)	W (±2")		
48	53	41	.109	.105	18	26	12	63	24	72 3/4	90	2 1/2 to 1	2 Pc.
54	60	46	.109	.105	18	30	12	70	30	82 1/4	102	2 to 1	2 Pc.
60	66	51	.109*	.105*	18	33	12	77	—	—	114	1 1/2 to 1	3 Pc.
66	73	55	.109*	.105*	18	36	12	77	—	—	126	1 1/2 to 1	3 Pc.
72	81	59	.109*	.105*	18	39	12	77	—	—	138	2 to 1	3 Pc.
78	87	63	.109*	.105*	22	38	12	77	—	—	148	1 1/2 to 1	3 Pc.
84	95	67	.109*	.105*	22	34	12	77	—	—	162	1 1/2 to 1	3 Pc.
90	103	71	.109*	.105*	22	38	12	77	—	—	174	1 1/2 to 1	3 Pc.
96	112	75	.109*	.105*	24	40	12	77	—	—	174	1 1/2 to 1	3 Pc.

NOTE: ALL SPLICES TO BE LAP RIVETED OR BOLTED. \* EXCEPT CENTER PANEL SEE GENERAL NOTES

REINFORCED CONCRETE PIPE ARCH										
EQUIV. DIA. (Inches)	DIMENSIONS (Inches)									APPROX. SLOPE
	**SPAN	**RISE	T	A	B	C	D	E		
24	29	18	3	8 1/2	39	33	72	48	3 to 1	
30	36	22	3 1/2	9 1/2	50	46	96	60	3 to 1	
36	44	27	4	11 1/8	60	36	96	72	3 to 1	
42	51	31	4 1/2	15 1/8	60	36	96	78	3 to 1	
48	58	36	5	21	60	36	96	84	3 to 1	
54	65	40	5 1/2	25 1/2	60	36	96	90	3 to 1	
60	73	45	6	31	60	36	96	96	3 to 1	
72	88	54	7	31	60	39	99	120	2 to 1	
84	102	62	8	28 1/2	83	19	102	144	2 to 1	

REINFORCED CONCRETE ELLIPTICAL PIPE										
EQUIV. DIA. (Inches)	DIMENSIONS (Inches)									APPROX. SLOPE
	**SPAN	**RISE	T	A	B	C	D	E		
24	30	19	3 1/4	8 1/2	39	33	72	48	3 to 1	
30	38	24	3 3/4	9 1/2	54	18	72	60	3 to 1	
36	45	29	4 1/2	11 1/8	60	24	84	72	2 1/2 to 1	
42	53	34	5	15 3/4	60	36	96	78	2 1/2 to 1	
48	60	38	5 1/2	21	60	36	96	84	2 1/2 to 1	
54	68	43	6	25 1/2	60	36	96	90	2 1/2 to 1	
60	76	48	6 1/2	30	60	36	96	96	2 1/2 to 1	

\*\*NOMINAL SIZE

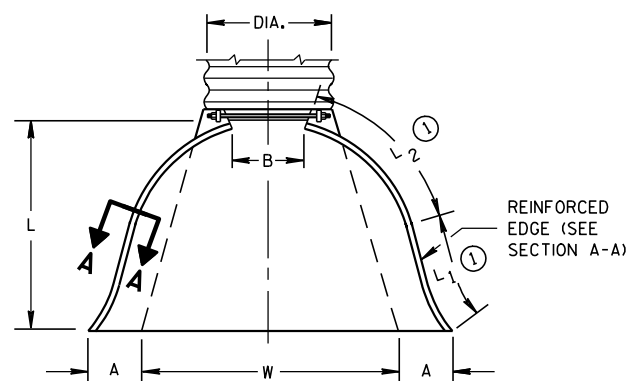

PLAN VIEW

END CORNER PLATES MAY BE FASTENED TO APRON PROPER BY BOLTS, RIVETS, OR RESISTANCE SPOT WELDS WHICH WILL HOLD THE SURFACES TIGHTLY TOGETHER

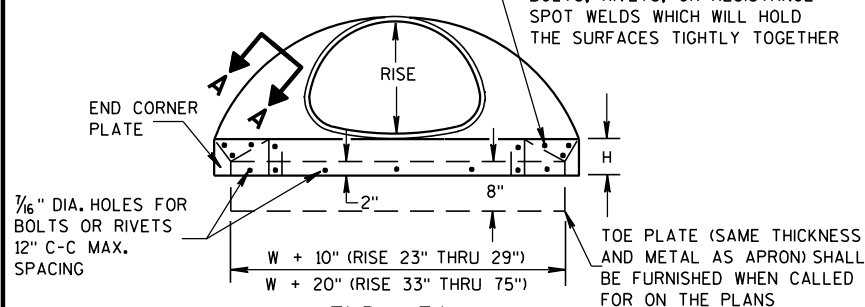

END VIEW

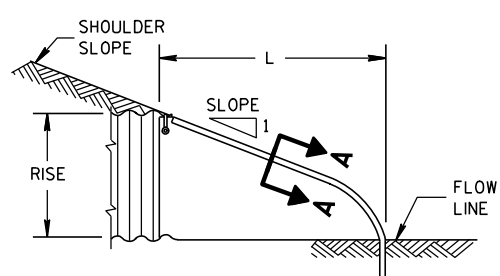

SIDE ELEVATION METAL ENDWALLS

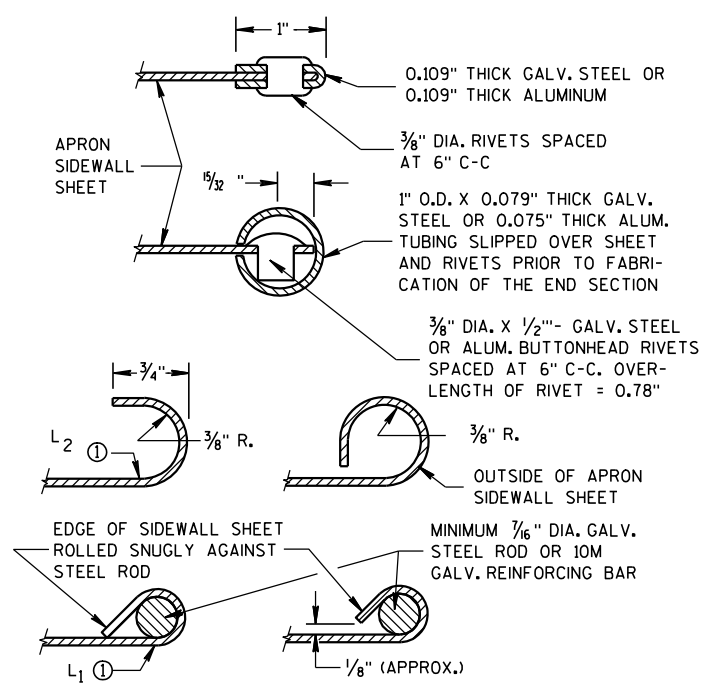

SECTION A-A

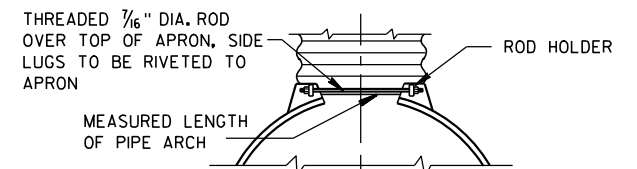

TYPE 2

FOR 17" X 13" THRU 112" X 75" PIPE ARCH

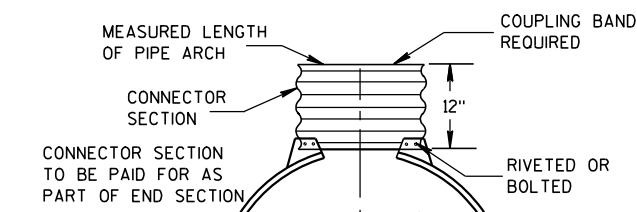

TYPE 3

FOR 64" X 43" THRU 112" X 75" PIPE ARCH

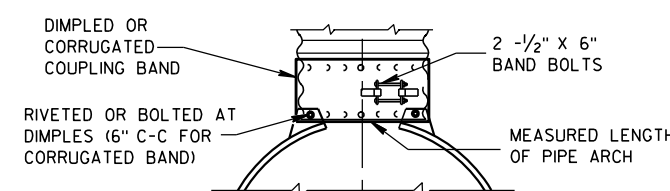

TYPE 5

ALTERNATE FOR: ALL SIZES CORRUGATED PIPE ARCHES

NOTE: DIMPLED BAND FITS OVER OUTSIDE OF ENDWALL, AND CORRUGATED BAND FITS INSIDE ENDWALL.

CONNECTION DETAILS

GENERAL NOTES

DETAILS OF CONSTRUCTION, MATERIALS AND WORKMANSHIP NOT SHOWN ON THIS DRAWING SHALL CONFORM TO THE PERTINENT REQUIREMENTS OF THE STANDARD SPECIFICATIONS AND THE APPLICABLE SPECIAL PROVISIONS.

CONCRETE APRON ENDWALLS MAY NOT BE USED WITH GALVANIZED STEEL OR ALUMINUM CULVERT PIPE OR VISE VERSA. GALVANIZED STEEL OR ALUMINUM APRON ENDWALLS SHALL NORMALLY BE INSTALLED ON CULVERT PIPE OF THE SAME METAL.

ALL THREE PIECE STEEL APRON ENDWALLS FOR 66" X 51" PIPE ARCH AND LARGER SHALL HAVE 0.109" SIDES AND 0.138" CENTER PANELS. ALL THREE PIECE ALUMINUM APRON ENDWALLS FOR 66" X 51" PIPE ARCH AND LARGER SHALL HAVE 0.105" SIDES AND 0.134" CENTER PANELS. THE WIDTH OF CENTER PANELS SHALL BE GREATER THAN 20 PERCENT OF THE PIPE ARCH PERIMETER.

LAP SEAMS SHALL BE TIGHTLY JOINED BY GALVANIZED RIVETS OR BOLTS FOR STEEL UNITS AND ALUMINUM RIVETS AND BOLTS FOR ALUMINUM UNITS. FOR THE 77" X 52" THROUGH 112" X 75" APRON ENDWALL SIZES, THE REINFORCED EDGES AND CENTER PANEL SEAMS SHALL BE FURTHER REINFORCED WITH GALVANIZED STEEL OR ALUMINUM STIFFENER ANGLES. THE ANGLES SHALL BE ATTACHED BY GALVANIZED NUTS AND BOLTS FOR STEEL UNITS AND ALUMINUM NUTS AND BOLTS FOR ALUMINUM UNITS.

WHERE TWO OR MORE PIPES WITH APRON ENDWALLS ARE LAID ADJACENT TO EACH OTHER, THEY SHALL BE SEPARATED BY A DISTANCE SUFFICIENT TO PROVIDE A MINIMUM CLEARANCE OF 6 INCHES BETWEEN APRON ENDWALLS.

Ⓛ FOR PIPE ARCH SIZES UP TO 73" X 55" A 180° ROLLED EDGE MAY BE USED INSTEAD OF STEEL ROD REINFORCEMENT. SEE SECTION A-A.

APRON ENDWALLS FOR PIPE ARCH AND ELLIPTICAL PIPE

STATE OF WISCONSIN DEPARTMENT OF TRANSPORTATION

APPROVED 11/30/94 /S/ Rory L. Rhinesmith CHIEF ROADWAY DEVELOPMENT ENGINEER  
DATE  
FHWA

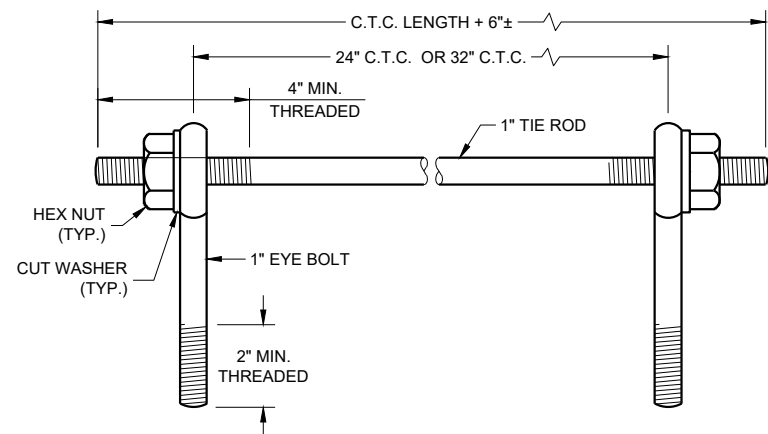

**EYE BOLTS AND TIE ROD**

**EYE BOLT AND TIE ROD ASSEMBLY (ALTERNATE NO. 1)**

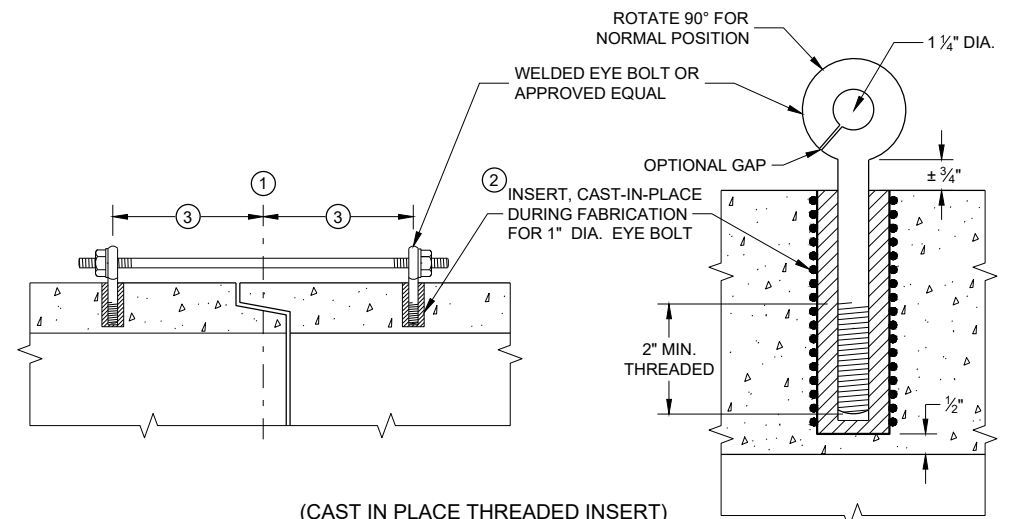

(CAST IN PLACE THREADED INSERT)  
**LONGITUDINAL SECTIONS**

**GENERAL NOTES**

DETAILS OF CONSTRUCTION, MATERIALS, AND WORKMANSHIP NOT SHOWN ON THIS DRAWING SHALL CONFORM TO THE PERTINENT REQUIREMENTS OF THE STANDARD SPECIFICATIONS AND APPLICABLE SPECIAL PROVISIONS.

CONCRETE CULVERT AND STORM SEWER PIPE SHALL BE TIED TOGETHER IN THE MANNER ILLUSTRATED BY THIS DETAIL AT LOCATIONS DESIGNATED IN THE STANDARD SPECIFICATIONS AND THE PLAN. THE CONTRACTOR MAY USE EITHER ALTERNATE 1, 2 OR 3 FOR DRAINAGE STRUCTURES. ONLY ALTERNATE 1 AND 3 MAY BE USED FOR CATTLE PASSES, UNLESS OTHERWISE STATED IN THE CONTRACT. THE MATERIALS, FABRICATION AND WORK NECESSARY TO TIE THE PIPE BY THIS DETAIL WILL BE CONSIDERED INCIDENTAL TO THE PIPE AND APRON ENDWALLS IF REQUIRED.

DETAILED DRAWINGS FOR PROPOSED ALTERNATE DESIGNS FOR JOINT TIES SHALL BE SUBMITTED TO THE ENGINEER FOR APPROVAL.

JOINT TIES TO BE HOT-DIP GALVANIZED PER ASTM A 153.

- ① CENTER LINE OF TONGUE AND GROOVE OR BELL AND SPIGOT JOINTS.
- ② THE INSIDE OF THE THREADED INSERTS SHALL BE CLEAN TO ALLOW THE INSERTION OF THREADED EYE BOLTS.
- ③ HOLES SHALL BE CAST-IN-PLACE OR DRILLED PER THE APPLICABLE DETAIL, AND EQUAL DISTANCE FROM THE CENTERLINE OF THE JOINT.
- ④ BOLT PROJECTION INSIDE OF PIPE SHALL NOT EXCEED 2 INCHES.
- ⑤ OPENING TO BE ROD DIAMETER PLUS 1 INCH.
- ⑥ LENGTH ADEQUATE TO EXTEND TO WITHIN 1/2 INCH OF THE INNER SURFACE OF THE PIPE.
- ⑦ EYE BOLT LENGTH DETERMINED BY WALL THICKNESS, BELL THICKNESS AND BOLT PROJECTION INSIDE PIPE.

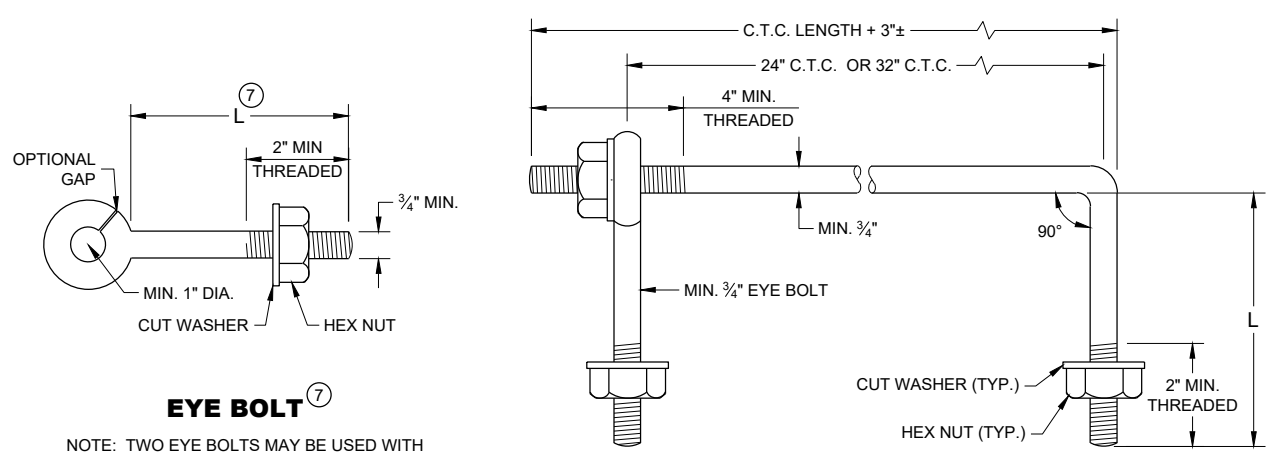

**EYE BOLT AND TIE ROD**

**EYE BOLT ⑦**

NOTE: TWO EYE BOLTS MAY BE USED WITH A 30" OR 38" LONG THREADED ROD IN LIEU OF THE 90° BENT TIE ROD.

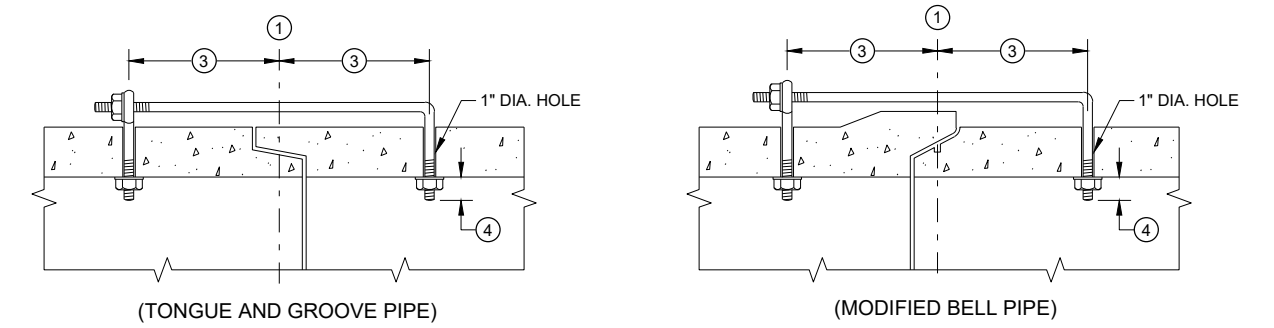

**LONGITUDINAL SECTION**  
(JOINT TIES FOR 18" TO 66" DIA. CONCRETE PIPE)

**EYE BOLT AND TIE ROD ASSEMBLY (ALTERNATE NO. 2)**

**ADJUSTABLE TIE ROD TABLE**

PIPE DIAMETER	TIE ROD DIAMETER	D	L <sub>1</sub>	N
12 - 60	5/8	5/8	5	1/2
66 - 84	3/4	3/4	5	1/2
90 - 144	1	1	7	1 7/16

DIMENSIONS SHOWN ARE IN INCHES

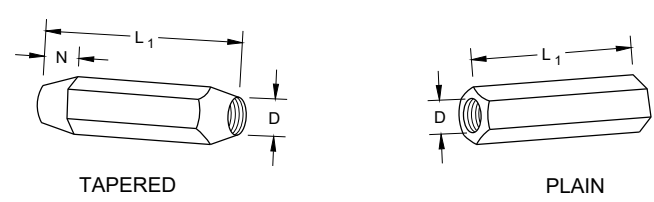

**RIGHT AND LEFT THREADS SLEEVE NUTS**

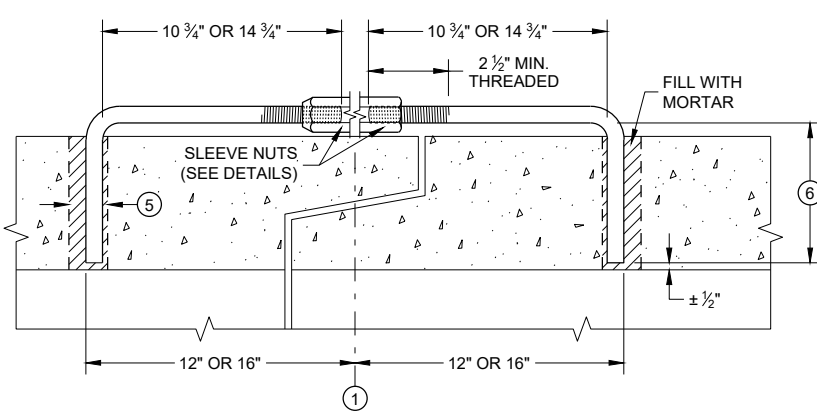

**LONGITUDINAL SECTION**  
**ADJUSTABLE TIE ROD (ALTERNATE NO. 3)**

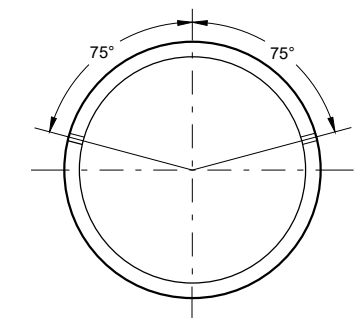

PLACEMENT OF (2) CAST-IN-PLACE INSERTS OR HOLES DURING FABRICATION FOR PIPE SECTIONS REQUIRING TIE RODS

**TRANSVERSE SECTION**

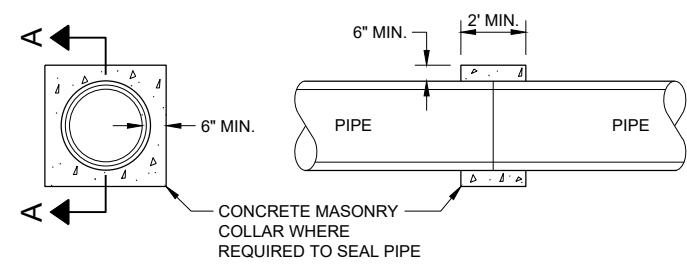

**SECTION A - A**  
**CONCRETE COLLAR DETAIL**

**JOINT TIES FOR CONCRETE PIPE AND CONCRETE COLLAR DETAIL**

STATE OF WISCONSIN  
DEPARTMENT OF TRANSPORTATION

APPROVED  
November 2021 /S/ Rodney Taylor  
DATE ROADWAY STANDARDS DEVELOPMENT  
ENGINEER  
FHWA

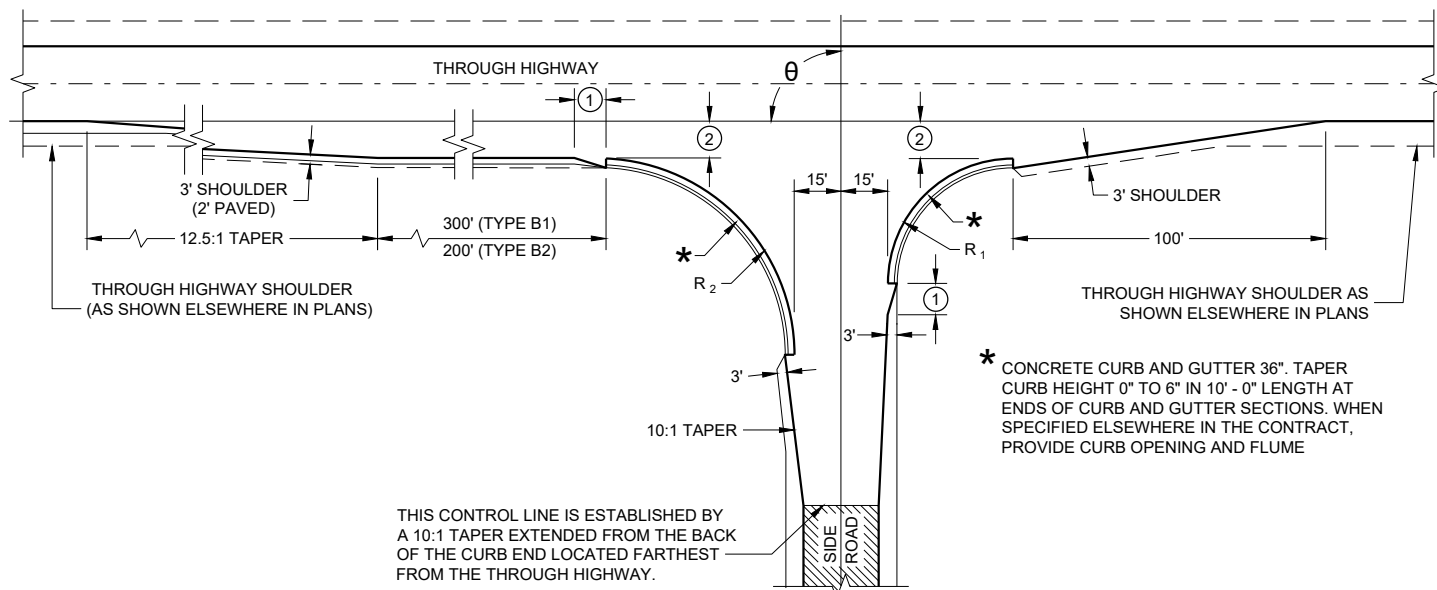

**TYPE "B1" AND "B2"**

**RADI DIMENSIONS FOR TYPES "B1", "B2", "C" AND "D" INTERSECTIONS**

$\theta$	$R_1$	$R_2$
65 - 70	35	70
71 - 80	40	70
81 - 90	40	60
91 - 100	50	55
101 - 110	60	45

**GENERAL NOTES**

DESIGNS MAY BE USED INTERCHANGEABLY IN COMBINATION OR SEPARATELY FOR ANY ONE COMPLETE INTERSECTION DEPENDING UPON INTERSECTION ANGLE AND SURFACING OF EACH APPROACH ROADWAY.

**SIDE ROAD SURFACING NOTE**

WHEN THE SIDE ROAD IS NOT PRESENTLY PAVED, PAVEMENT SHALL BE PLACED TO THE LIMITS SHOWN UNLESS OTHERWISE PROVIDED IN THE CONTRACT. WHERE THE CONSTRUCTION LIMITS ARE BEYOND THE PAVING LIMITS, CRUSHED AGGREGATE SURFACING SHALL BE PLACED BETWEEN THE PAVING LIMITS AND CONSTRUCTION LIMITS.

WHEN THE SIDE ROAD IS PRESENTLY PAVED, NEW PAVEMENT SHALL BE PLACED TO THE LIMITS OF DESIGN AS SHOWN AND BEYOND, IF NECESSARY, TO MEET EXISTING PAVEMENT.

WHEN THE SIDE ROAD IS THE CONSTRUCTION PROJECT, THE INTERSECTION SURFACING SHALL BE THE SAME AS FOR THE PROJECT.

- ① 10-FT TYPICAL.
- ② 12-FT\*\* PLUS ADDITIONAL WIDTH FOR BIKE LANE IF SHOWN ELSEWHERE IN THE PLAN.  
\*\*10-FT MAY BE USED ON TYPE B2 ON RESURFACING PROJECTS IF SPECIFIED IN THE CONTRACT.
- ③ BYPASS LANE PAVED SURFACE WIDTH OUTSIDE OF TRAVEL LANE  
- ASPHALT = 12-FT PLUS PAVED SHOULDER WIDTH  
- PC CONCRETE = 13-FT PLUS PAVED SHOULDER WIDTH
- ④ BYPASS LANE PAVED SHOULDER WIDTH = THE GREATER OF 1-FT OR THE PAVED SHOULDER WIDTH OF THE THROUGH HIGHWAY.

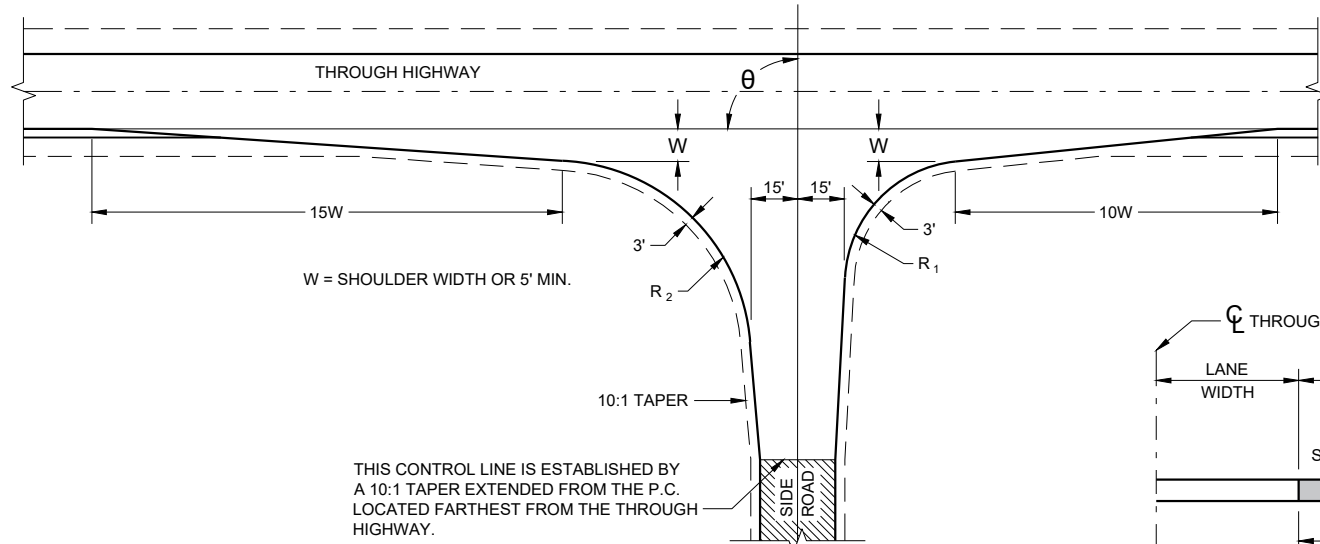

**TYPE "C"**

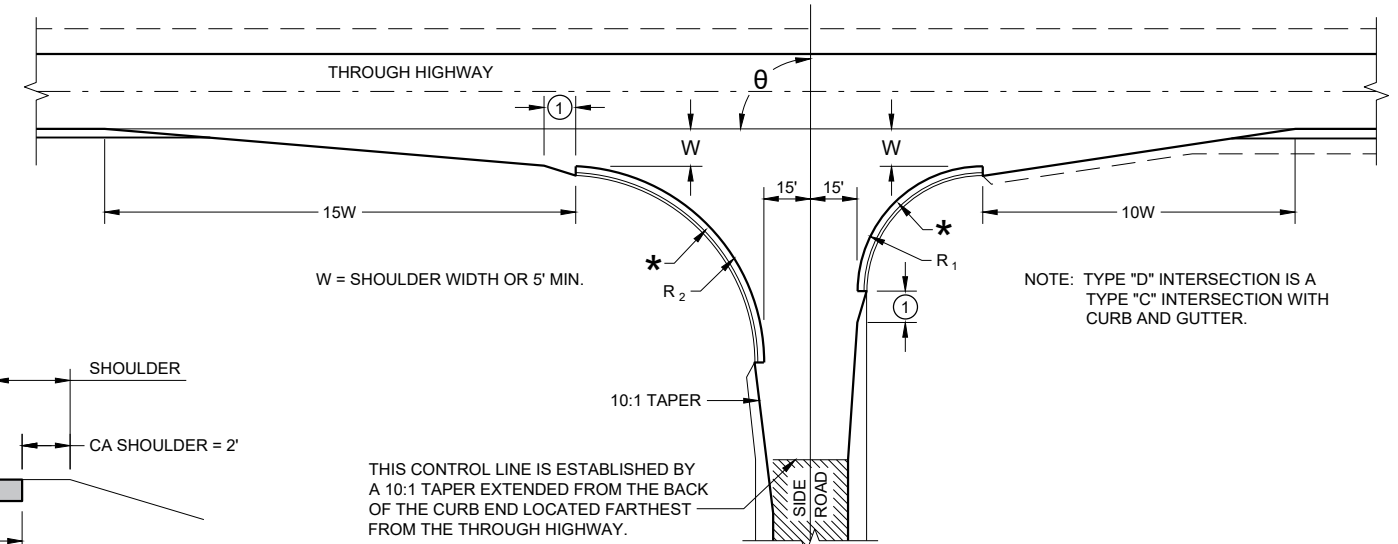

**TYPE "D"**

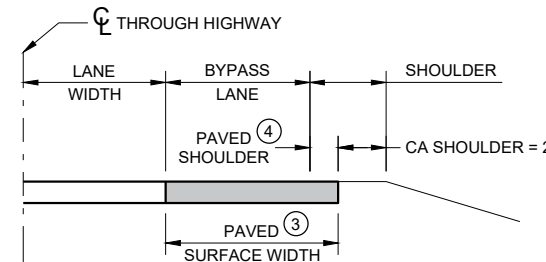

**SECTION A - A**

(SHOWING BYPASS LANE AND SHOULDER)

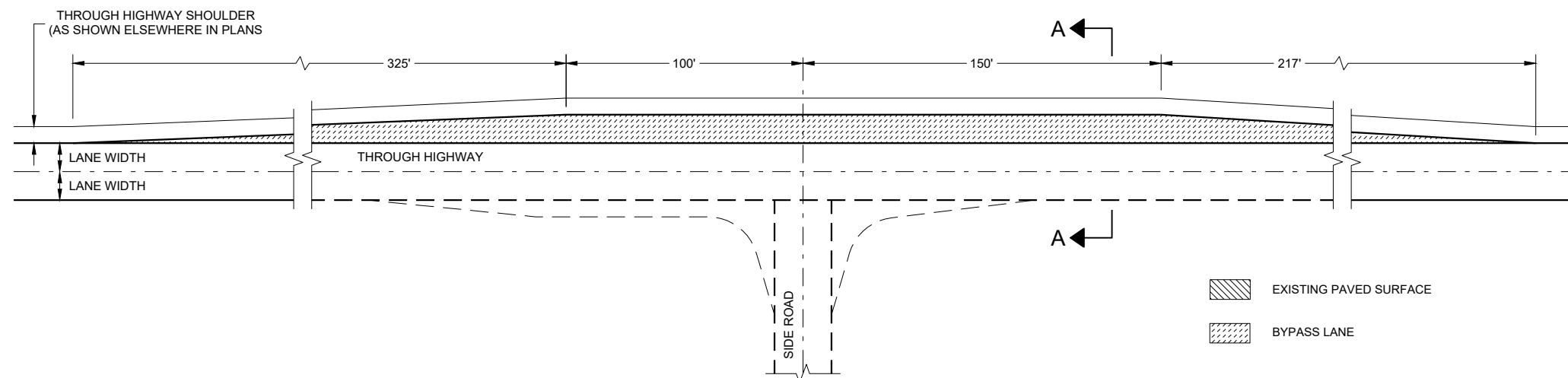

**TEE INTERSECTION BYPASS LANE DETAIL**

EXISTING PAVED SURFACE  
BYPASS LANE

**AT GRADE SIDE ROAD INTERSECTION TYPES "B1", "B2", "C", "D" AND TEE INTERSECTION BYPASS LANE**

STATE OF WISCONSIN  
DEPARTMENT OF TRANSPORTATION

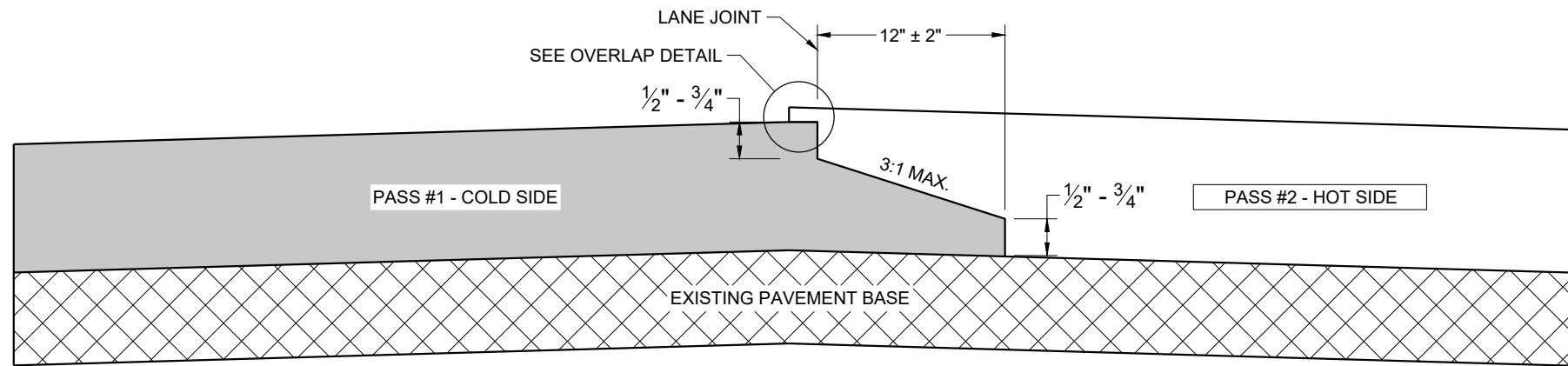

**TYPICAL PAVEMENT CROSS SECTION  
NOTCHED WEDGE JOINT**

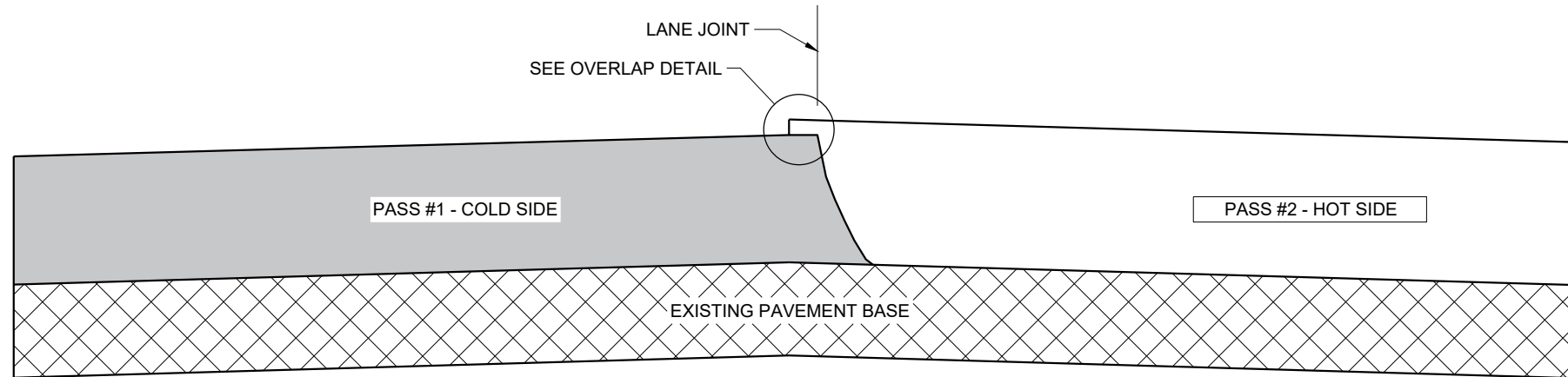

**TYPICAL PAVEMENT CROSS SECTION  
VERTICAL JOINT**

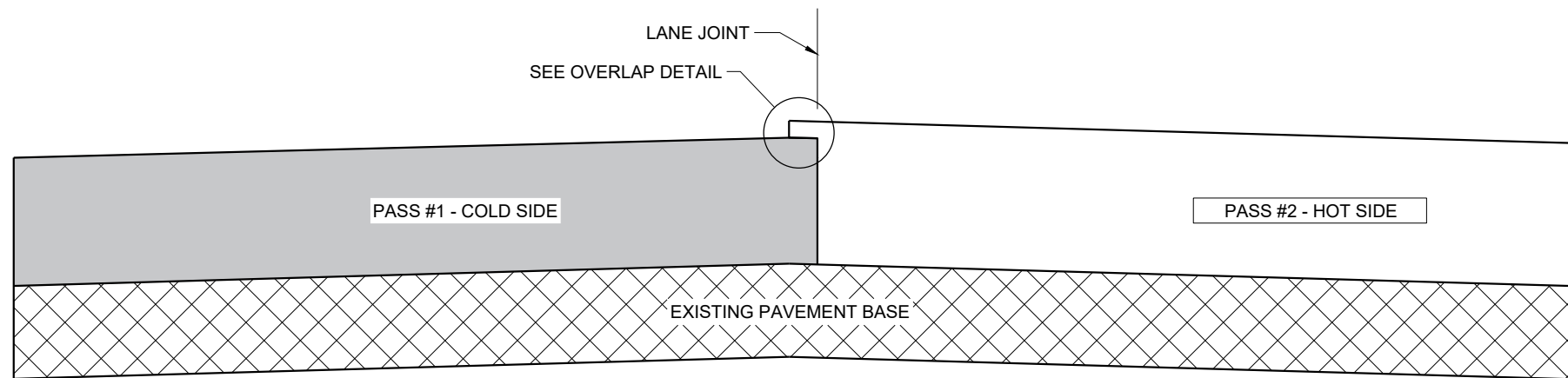

**TYPICAL PAVEMENT CROSS SECTION  
VERTICAL JOINT (MILLED)**

**GENERAL NOTES**

IN ADDITION TO THE DETAILS PROVIDED IN THIS DRAWING, CONFORM TO STANDARD SPECIFICATION 450.3.2.8 FOR WHEN A NOTCHED WEDGE JOINT IS REQUIRED AND FOR GENERAL JOINT CONSTRUCTION REQUIREMENTS.

FOR ALL LONGITUDINAL JOINTS, ENSURE THE PAVER SCREED OVERLAPS THE PREVIOUSLY PLACED PAVEMENT BY  $1" \pm 0.5"$  AND THE HOT SIDE OF THE JOINT REMAINS HIGHER THAN THE COLD SIDE BY APPROXIMATELY 0.1" AFTER FINAL COMPACTION. (IT WILL BE FLUSH WHEN PAVING IN ECHELON.)

ONLY REMOVE THE LONGITUDINAL NOTCHED WEDGE JOINT FOR SMA PAVEMENT OR AS DIRECTED BY THE ENGINEER TO ADDRESS SPECIFIC LENGTHS OF JOINT DAMAGED BY TRAFFIC.

WHEN MILLING BACK OR REMOVING ANY LONGITUDINAL JOINT, LIMIT THE MATERIAL REMOVED TO 2" FROM THE TOP NOTCH OR FROM THE VERTICAL JOINT EDGE ON THE COLD SIDE OF THE JOINT.

USE LONGITUDINAL MILLED JOINT AS PLANS SHOW OR THE AS THE ENGINEER DIRECTS.

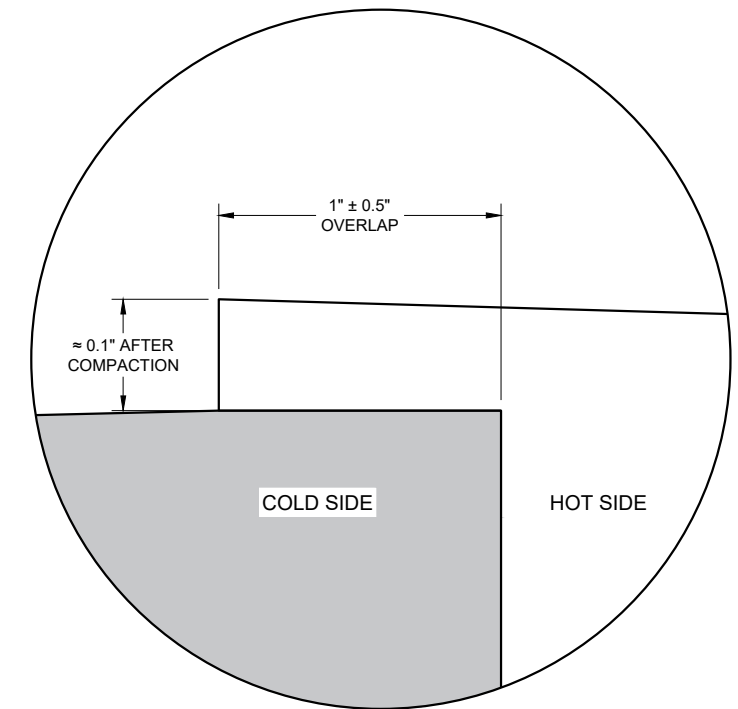

**OVERLAP DETAIL (TYPICAL)**

6

6

SDD 13C19 - 03

SDD 13C19 - 03

<b>HMA LONGITUDINAL JOINTS</b>	
STATE OF WISCONSIN DEPARTMENT OF TRANSPORTATION	
APPROVED November 2020 DATE	/S/ Steven Hefel HMA PAVEMENT ENGINEER
FHWA	

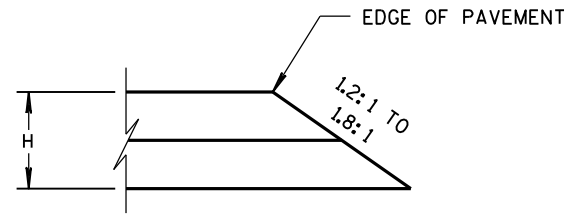

CONSTRUCTED WITH FINAL TWO LAYERS  
FOR H 5" OR LESS

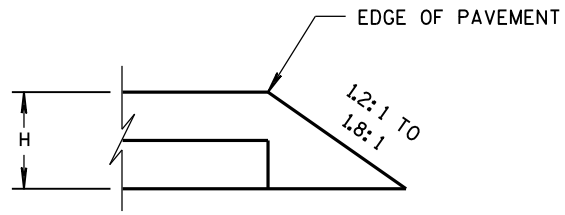

CONSTRUCTED WITH FINAL LAYER  
FOR H 5" OR LESS

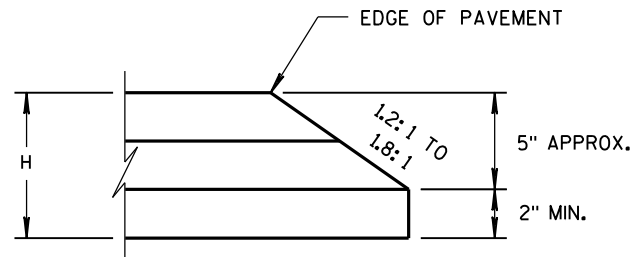

CONSTRUCTED WITH FINAL TWO LAYERS  
FOR H GREATER THAN 5"

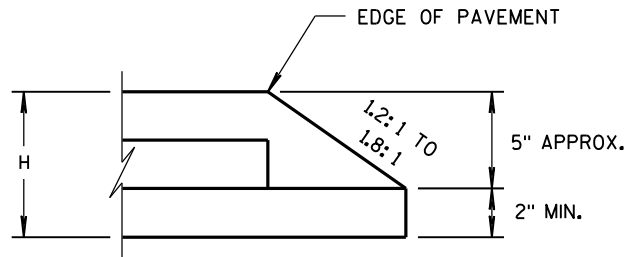

CONSTRUCTED WITH FINAL LAYER  
FOR H GREATER THAN 5"

HMA PAVEMENT AND HMA OVERLAYS

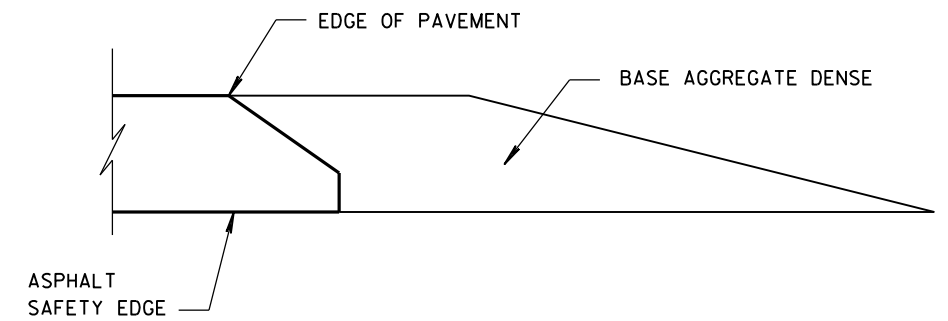

FINISHED SHOULDER AGGREGATE PLACEMENT

6

6

S.D.D. 14 B 29-1

S.D.D. 14 B 29-1

SAFETY EDGE <sub>SM</sub>	
STATE OF WISCONSIN DEPARTMENT OF TRANSPORTATION	
APPROVED DATE	/s/ Jerry H. Zogg ROADWAY STANDARDS DEVELOPMENT ENGINEER
FHWA	





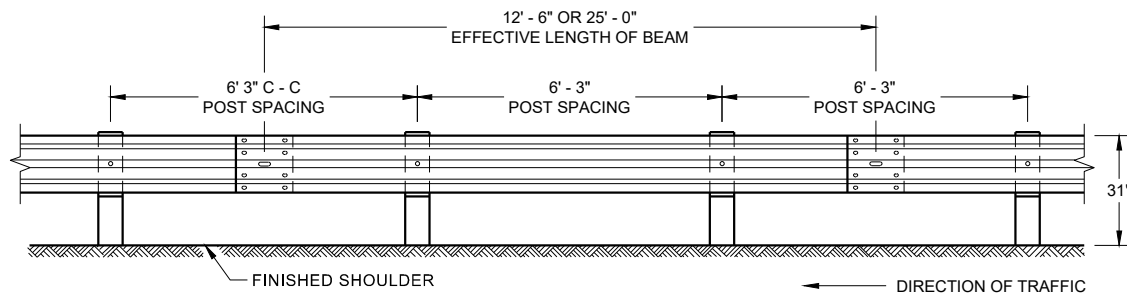

**FRONT VIEW  
POST SPACING STANDARD INSTALLATION**

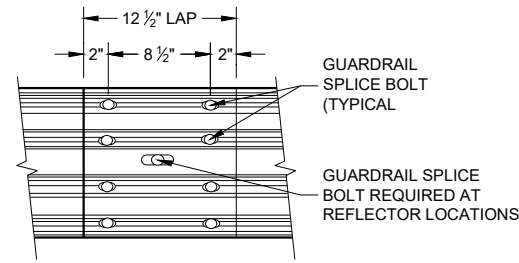

**FRONT VIEW  
MID-SPAN BEAM SPLICE**

**GENERAL NOTES**

- ⑧ DO NOT INSTALL REFLECTORS ON THE FIRST 50 FEET OF THE APPROACH END OF THE ENERGY ABSORBING TERMINAL.
  - ⑨ 25 FEET OF HALF POST SPACING IS REQUIRED ON APPROACH AND DEPARTURE ENDS OF QUARTER POST SPACING.
- POST BOLTS ARE A 3/8" DIAMETER ASTM A307 GUARDRAIL BOLT. A POST BOLT REQUIRES 3/4" DIAMETER A563A DOUBLE RECESSED (DR) HEAVY HEX NUT AND 3/8" DIAMETER F844 FLAT WASHER. POST BOLTS MAY BE LONGER IF MULTIPLE BLOCKOUTS ARE BEING USED.
- GUARD RAIL SPLICE BOLTS ARE A 3/8" DIAMETER ASTM A307 GUARDRAIL HEAD BOLT. A GUARDRAIL SPLICE BOLT REQUIRES 3/8" DIAMETER A563A DOUBLE RECESSED (DR) HEAVY HEX NUT.

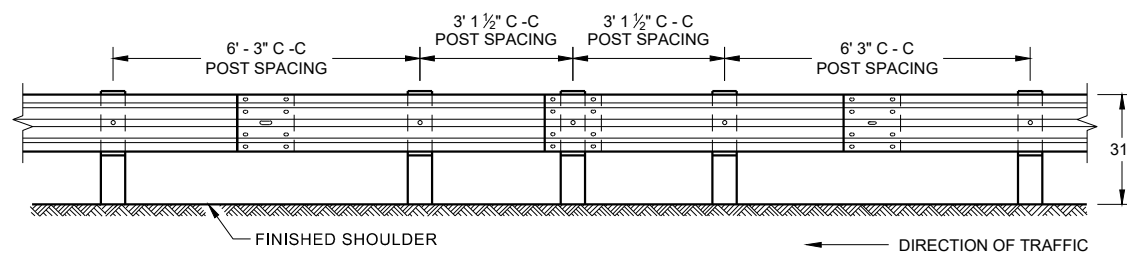

**FRONT VIEW  
HALF POST SPACING (HS) AND  
HALF POST SPACING WITH LONGER POSTS (K)**

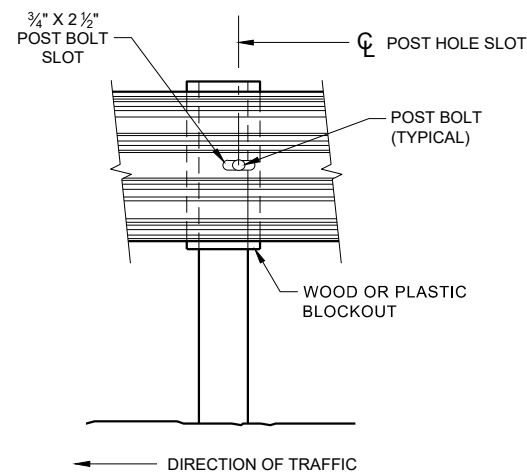

**FRONT VIEW AT STEEL POST**

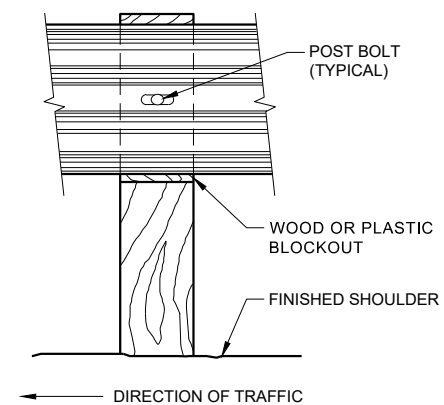

**FRONT VIEW AT WOOD POST**

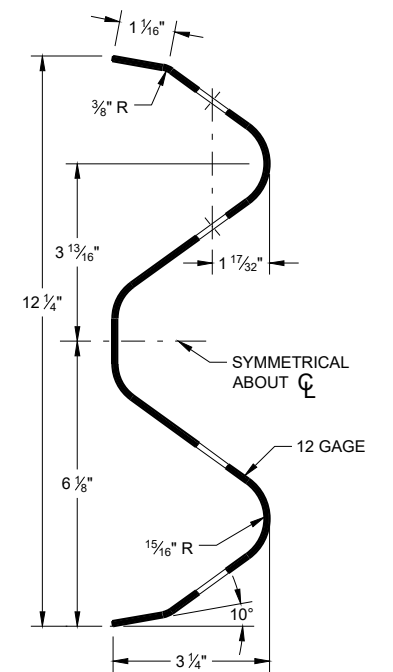

**SECTION THRU W-BEAM RAIL**

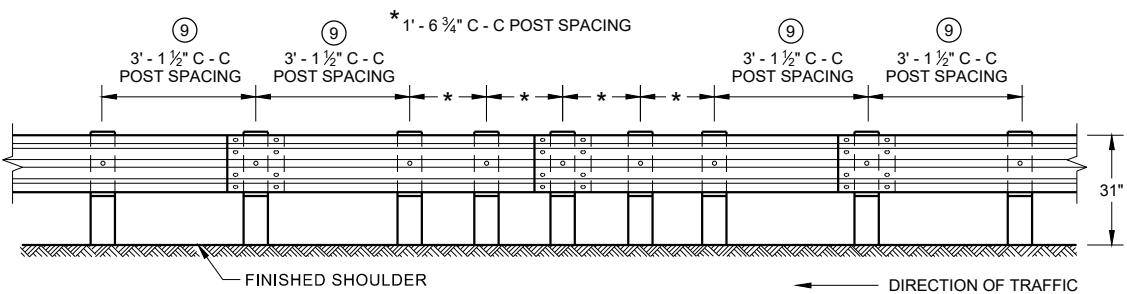

**FRONT VIEW  
QUARTER POST SPACING (QS)**

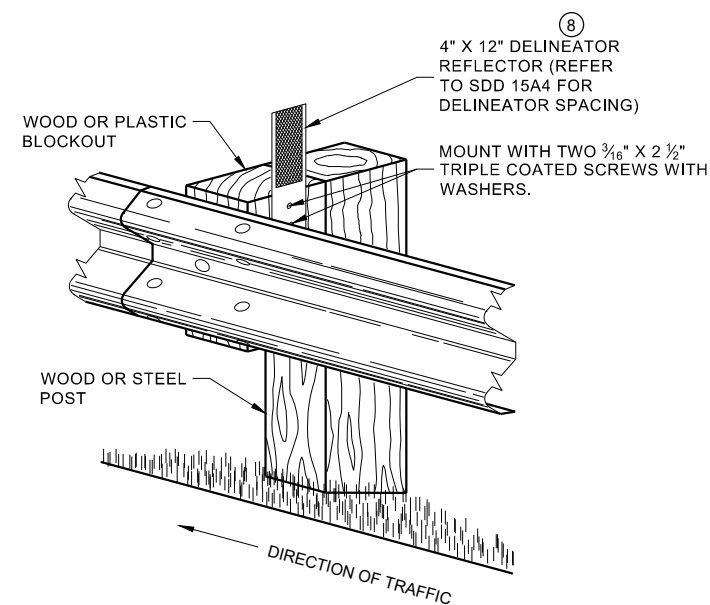

**ONE SIDED REFLECTOR DETAIL  
AND TYPICAL INSTALLATION**

**MIDWEST GUARDRAIL SYSTEM  
(MGS) GUARDRAIL**

STATE OF WISCONSIN  
DEPARTMENT OF TRANSPORTATION

6

6

SDD 14B42 - 07b

SDD 14B42 - 07b

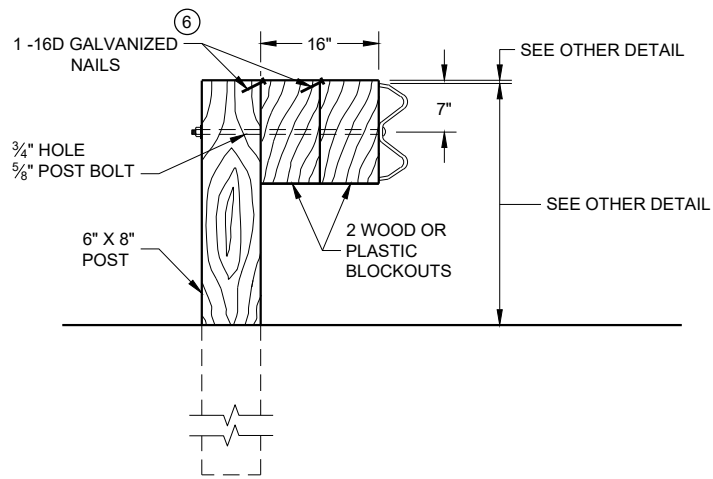

**DETAIL FOR 16" BLOCKOUT DEPTH**

IT IS ACCEPTABLE TO USE BLOCKOUTS UP TO 16" DEEP TO INCREASE THE POST OFFSET TO AVOID UNDERGROUND OBSTACLES. THERE IS NO LIMIT TO THE NUMBER OF POSTS THAT CAN HAVE ADDITIONAL BLOCKOUTS UP TO 16" DEEP.

**NOTE:**

1. ALL FILLETS SHALL HAVE A MINIMUM RADIUS OF 3/16".
2. IF THE BOLT EXTENDS MORE THAN 1/4" FROM THE NUT THE BOLT SHOULD BE TRIMMED BACK.

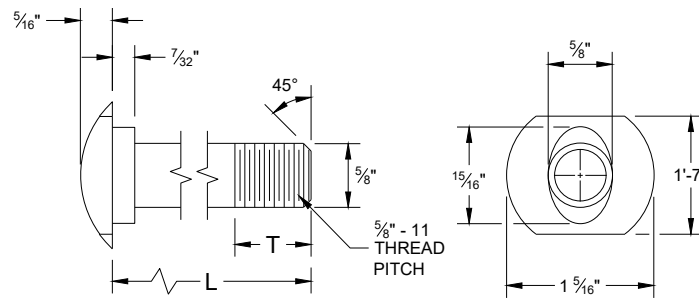

**POST BOLT TABLE**

L	T (MIN.)
1 1/4"	1 1/8"
2"	1 3/4"
10"	4"
14"	4 1/16"
18"	4"
21"	4 1/16"
25"	4"

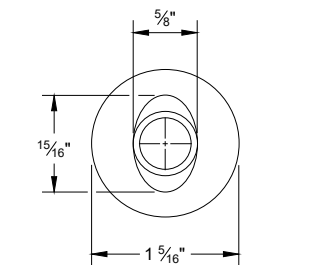

**ALTERNATE BOLT HEAD**

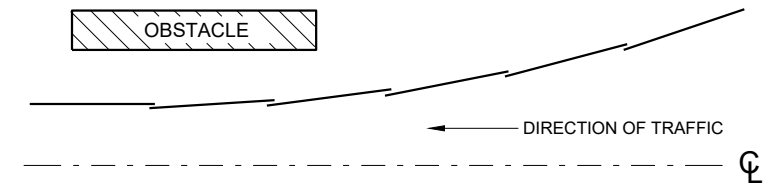

**PLAN VIEW  
BEAM LAPPING DETAIL**

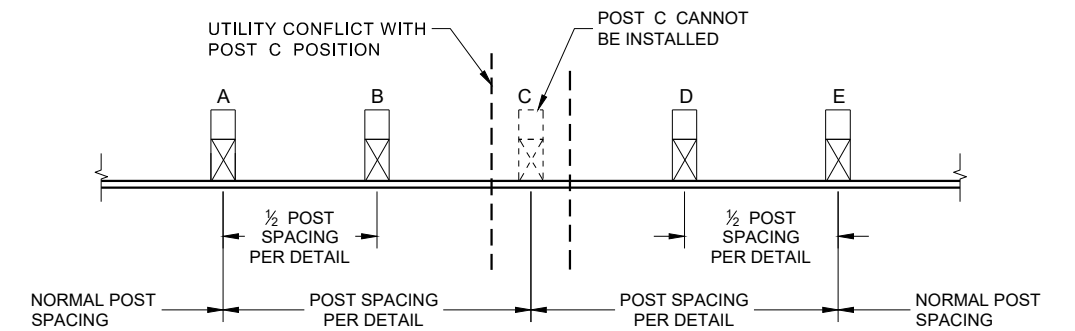

**POST DRIVING FOR CONTINUOUS  
UNDERGROUND OBSTRUCTION**

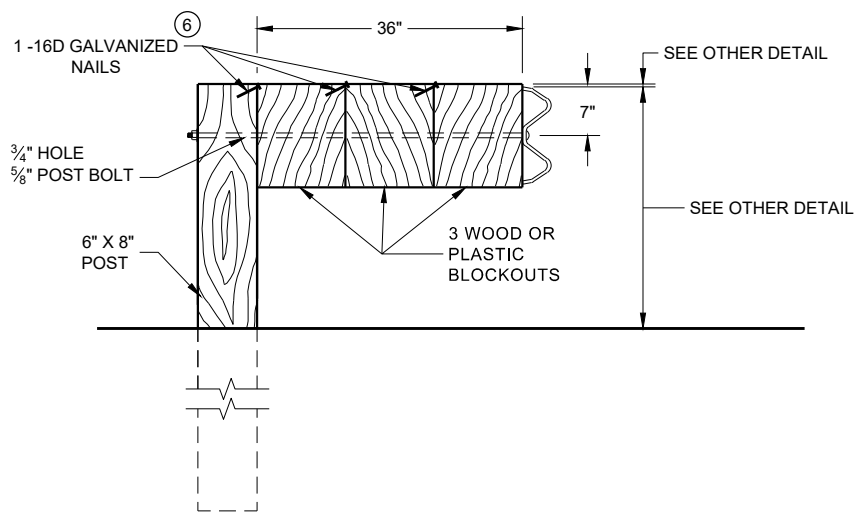

**DETAIL FOR 36" BLOCKOUT DEPTH**

NOTES: UNDER SPECIAL CIRCUMSTANCES, SUCH AS AVOIDING OBSTACLES THAT ARE NOT RELOCATED, IT IS ACCEPTABLE TO INSTALL ADDITIONAL BLOCKOUTS TO OBTAIN UP TO 36" DEPTH FOR ONE OR TWO POSTS IN A SECTION OF GUARDRAIL.  
DO NOT USE 16" OR 36" BLOCKOUTS IF IT CAUSES THE POST TO BE DRIVEN BEYOND SHOULDER HINGE POINT OR CAUSES A FIXED OBJECT TO BE WITHIN THE DEFLECTION DISTANCE OF THE BARRIER.

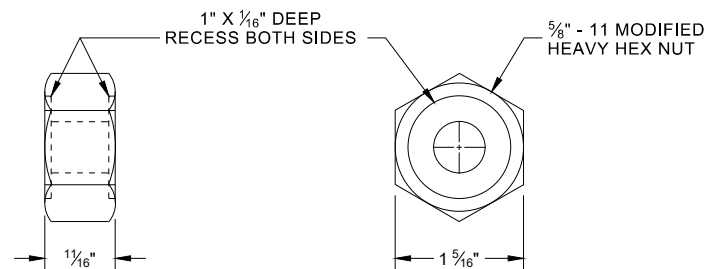

**POST BOLT, SPLICE BOLT  
AND RECESS NUT**

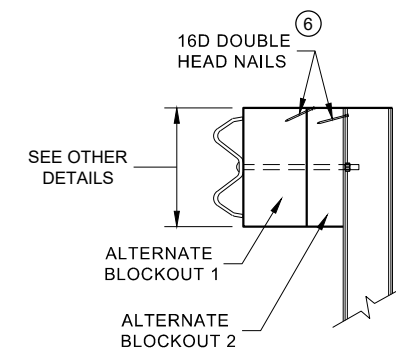

**SIDE VIEW**

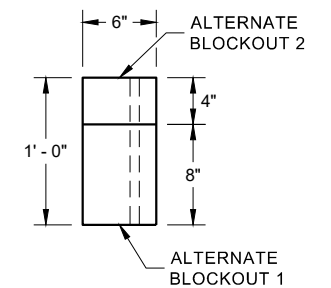

**PLAN VIEW**

**ALTERNATE WOOD  
BLOCKOUT DETAIL**

6 WHEN USING STEEL POST AND WOOD BLOCKOUTS, INSTALL FOUR 16D GALVANIZED NAILS. INSTALL NAILS AT THE BACK CORNERS OF THE BLOCK AND BEND THE NAILS OVER THE FLANGE OF THE STEEL POST.

**MIDWEST GUARDRAIL SYSTEM  
(MGS) GUARDRAIL**

STATE OF WISCONSIN  
DEPARTMENT OF TRANSPORTATION

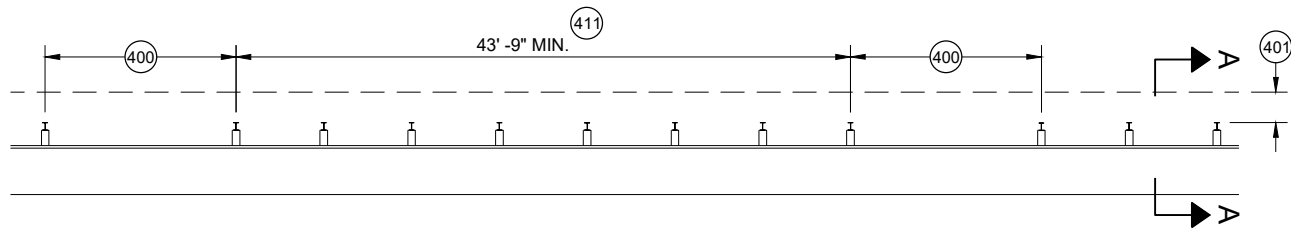

**MISSING POST IN MGS GUARDRAIL**

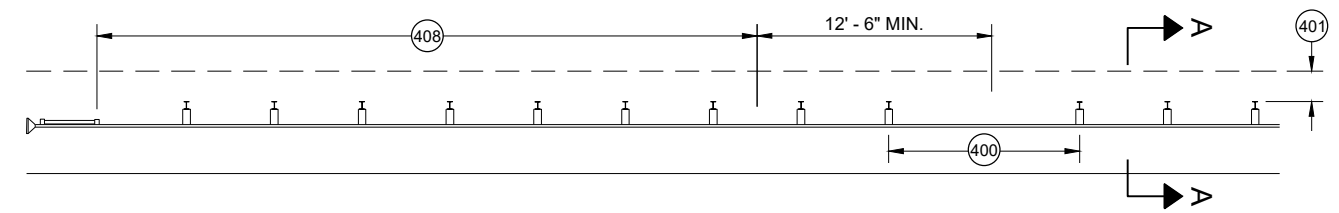

**MISSING POST IN MGS GUARDRAIL NEAR EAT**

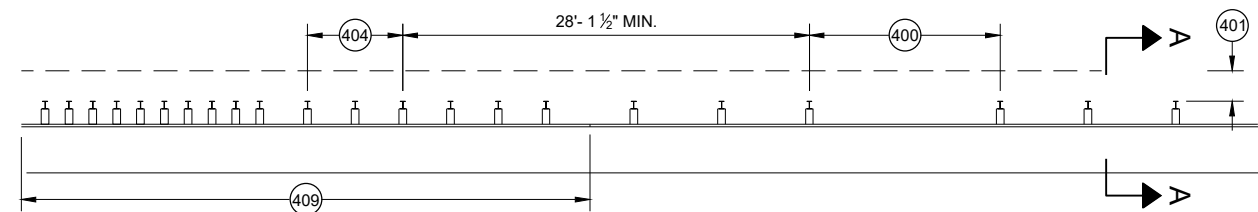

**MISSING POST IN MGS GUARDRAIL NEAR AN APPROACH TRANSITION**

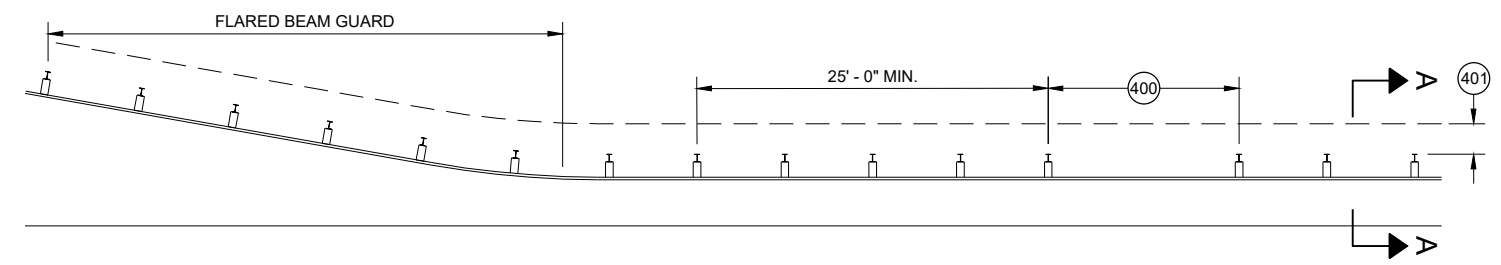

**MISSING POST IN MGS GUARDRAIL NEAR FLARED BEAM GUARD**

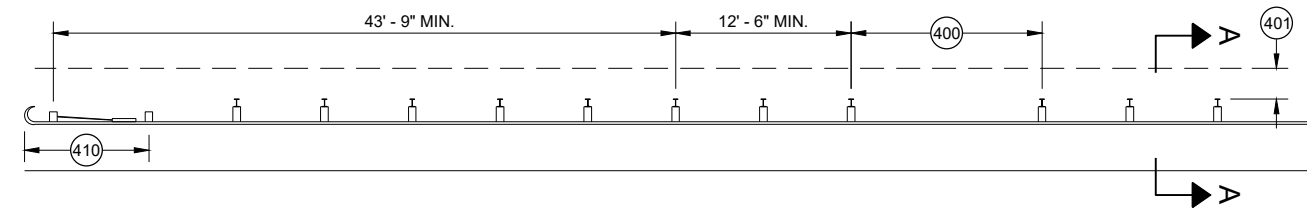

**MISSING POST IN MGS GUARDRAIL NEAR A TYPE 2 END TERMINAL**

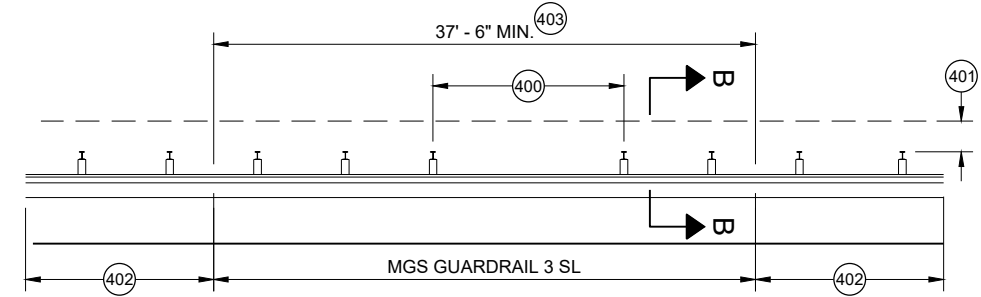

**MISSING POST IN SHORT SPAN MGS GUARDRAIL NEAR CURB (SL)**

- 400 MAX SPAN 12' - 6"
- 401 2' MIN.
- 402 MGS GUARDRAIL 3
- 403 NESTING BEAM GUARD
- 404 ASYMMETRIC TRANSITION
- 405 SOIL WELL DRAINED AND COMPACTED
- 406 SEE OTHER DRAWINGS IN THIS SDD
- 407 SEE OTHER DRAWINGS FOR MIN. SPACING BETWEEN SPANS
- 408 SEE SDD 14B44
- 409 SEE SDD 14B45
- 410 SEE SDD 14B47
- 411 MINIMUM DISTANCE BETWEEN MISSING POST SPANS.

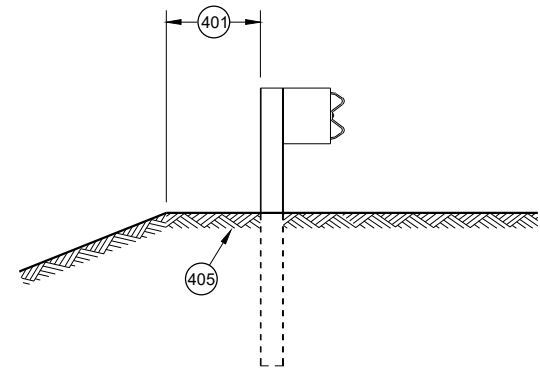

**SECTION A - A**

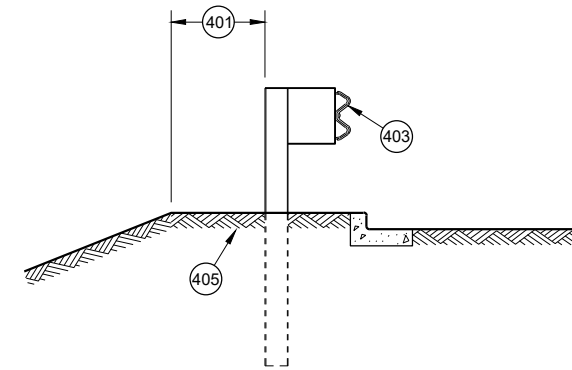

**SECTION B - B**

<b>MIDWEST GUARDRAIL SYSTEM (MGS) GUARDRAIL</b>	
STATE OF WISCONSIN DEPARTMENT OF TRANSPORTATION	
APPROVED May 2021 DATE	/S/ Rodney Taylor ROADWAY STANDARDS DEVELOPMENT UNIT SUPERVISOR
<small>FHWA</small>	

**GENERAL NOTES**

- (A) THE SLOPE IN THE AREA BOUNDED BY THE GRADELINE, THE HINGE POINT LINE AND THE CLEAR ZONE LIMITS (CZL) SHALL BE 4:1 OR FLATTER.
  - (B) AFTER FINAL ASSEMBLY, RECHECK CABLE TO BE SURE IT IS TAUT AND HAS NOT RELAXED
  - (C) DIFFERENT MANUFACTURERS REQUIRE DIFFERENT PERFORATED W - BEAM RAIL END PANELS. SEE MANUFACTURER'S INFORMATION.
  - (D) ATTACH ALUMINUM SHEET TO E.A.T. HEAD USING 4 STAINLESS STEEL SELF - TAPPING SCREWS. ONE SCREW PER CORNER.
  - (E) HARDWARE MAY VARY BETWEEN MANUFACTURER. SEE MANUFACTURER'S DRAWING FOR INFORMATION.
- DIMENSIONS MAY VARY, MANUFACTURER'S INFORMATION.

SEE SDD 14B42 FOR MORE INFORMATION.

\* DO NOT ATTACH BLOCKOUTS TO POST 1 AND 2.

DO NOT INSTALL REFLECTORS ON THE FIRST 50 FEET OF THE APPROACH END OF THE ENERGY ABSORBING TERMINAL.

SEE MANUFACTURER'S DRAWING FOR SPLICE LOCATION, HARDWARE DIMENSIONS AND INSTALLATION INSTRUCTIONS.

THE CENTER OF THE UPPER 3 1/2" DIAMETER HOLE ON POST NUMBER 3 THROUGH POST 9 IS TO BE FLUSH WITH THE GROUND LINE UP TO A MAXIMUM OF 2" ABOVE GROUND LINE. WOOD BLOCKS ON POSTS NUMBERED 3 THROUGH 9 MAY BE ADJUSTED UP TO 3" ABOVE THE TOP OF POST.

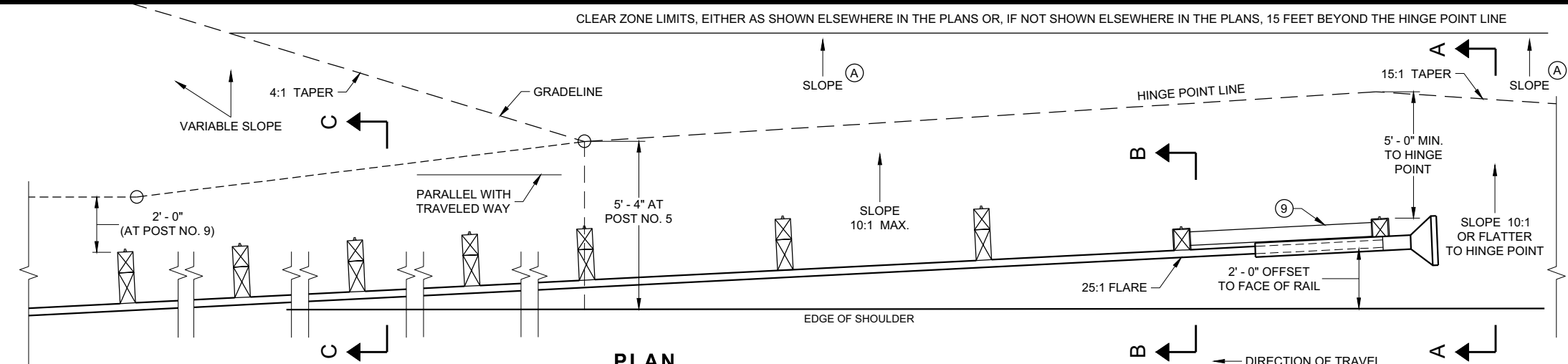

**PLAN**

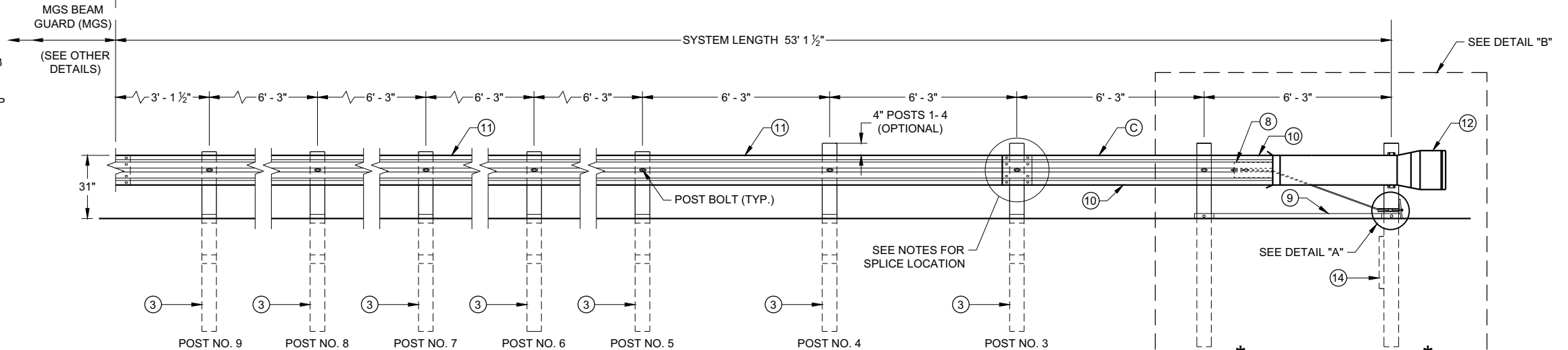

**ELEVATION**

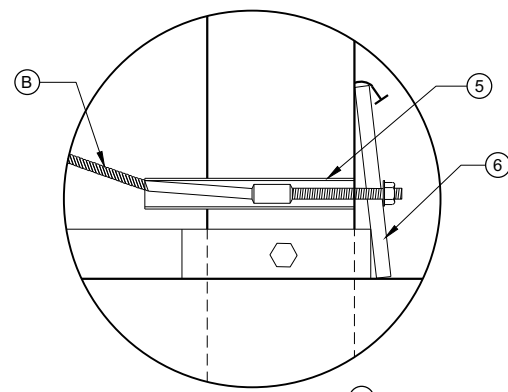

**DETAIL "A"**

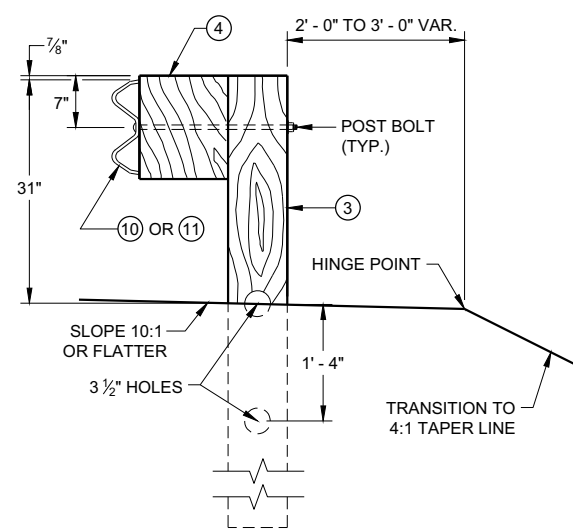

**SECTION C - C  
TYPICAL AT POST NOS. 3 - 9**

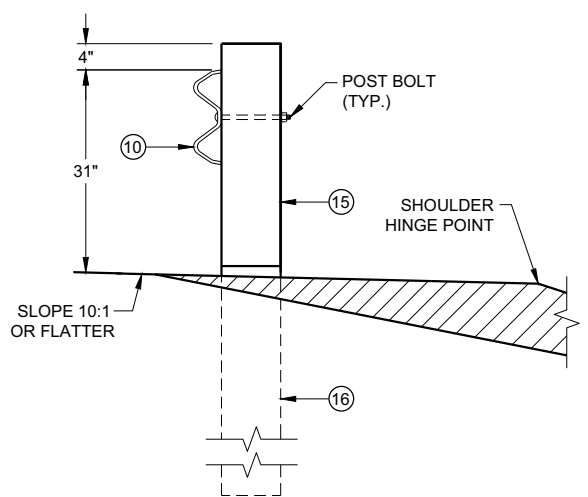

**SECTION B - B  
TYPICAL AT POST NO. 2\***

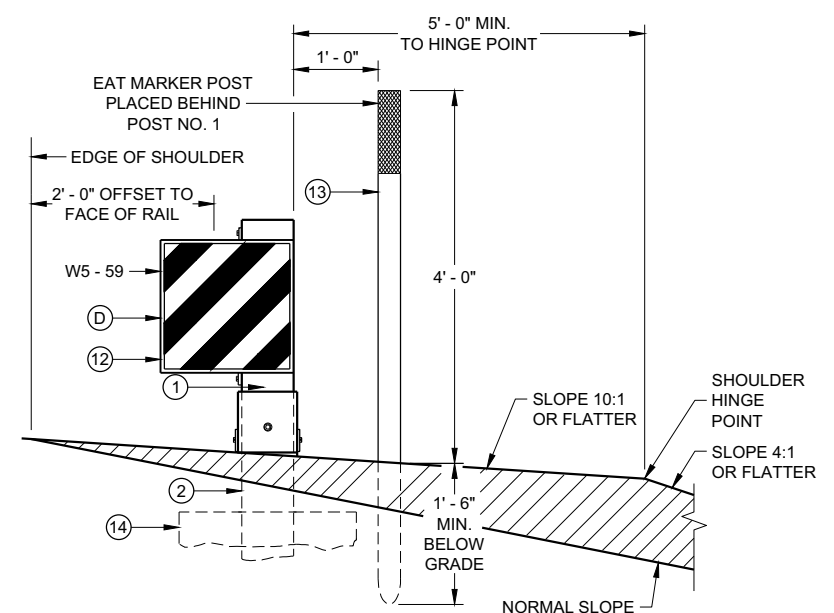

**SECTION A - A  
TYPICAL AT POST NO. 1\***

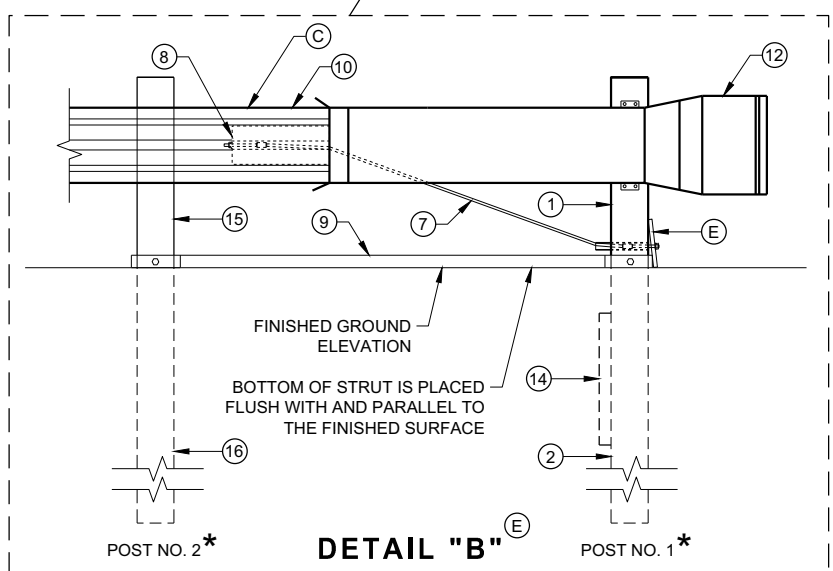

**DETAIL "B"**

**MIDWEST GUARDRAIL SYSTEM  
ENERGY ABSORBING TERMINAL  
(MGS)**

STATE OF WISCONSIN  
DEPARTMENT OF TRANSPORTATION

6

6

SDD 14B44 - 04a

SDD 14B44 - 04a

**BILL OF MATERIALS**

PART NO.	DESCRIPTION MATERIALS PROVIDED BY MGS EAT MANUFACTURER. SEE MANUFACTURER'S DETAILS FOR MORE INFORMATION.
①	UPPER POST NO. 1 6" X 6" TUBE
②	LOWER POST NO. 1
③	WOOD CRT
④	WOOD BLOCKOUT
⑤	PIPE SLEEVE
⑥	BEARING PLATE
⑦	BCT CABLE ASSEMBLY
⑧	ANCHOR CABLE BOX
⑨	GROUND STRUT
⑩	PERFORATED W-BEAM RAIL END PANEL, 12'-6" LONG.
⑪	STANDARD W-BEAM RAIL. MULTIPLE SECTIONS REQUIRED. SECTIONS VARY IN LENGTH.
⑫	IMPACT HEAD
⑬	EAT MARKER POST - YELLOW (SEE APPROVED PRODUCTS LIST)
⑭	SOIL PLATE
⑮	UPPER POST NO. 2
⑯	LOWER POST NO. 2

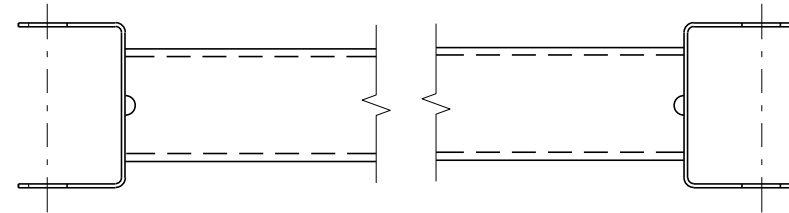

**GENERIC GROUND STRUT** ⑨ ⑤

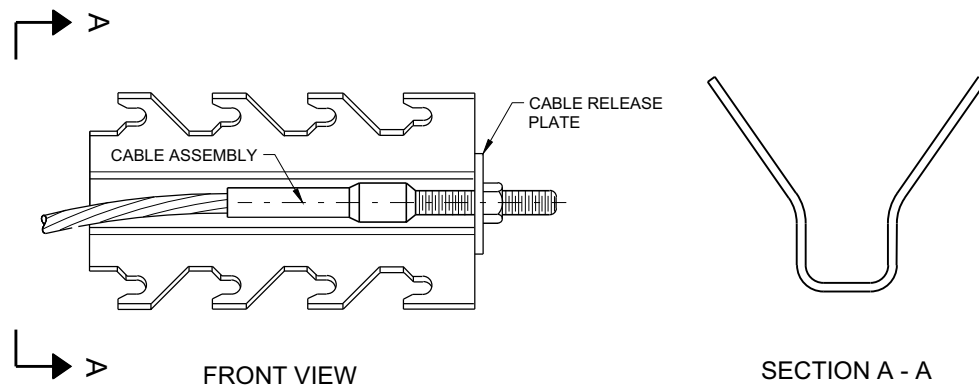

**GENERIC ANCHOR CABLE BOX** ⑨ ⑤

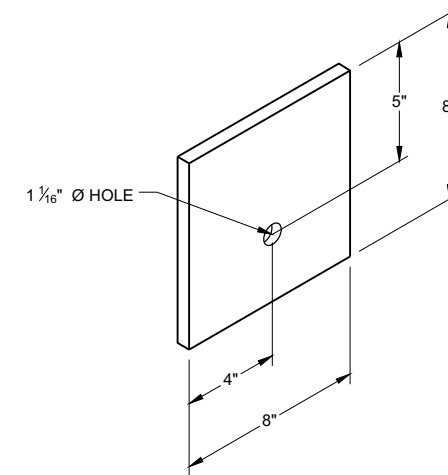

**BEARING PLATE** ⑥ ⑤

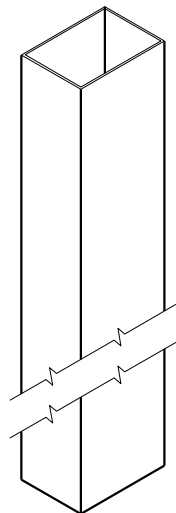

UPPER POST NO. 1 <sup>(1)</sup> (E)

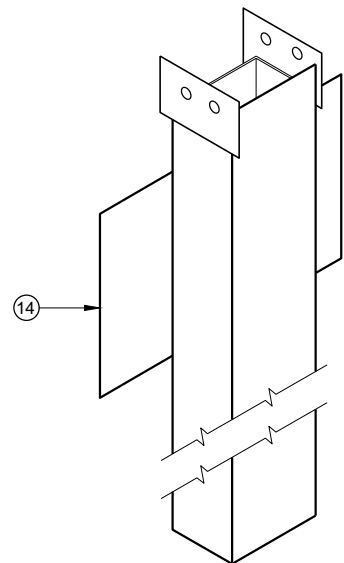

LOWER POST NO. 1 <sup>(2)</sup> (E)

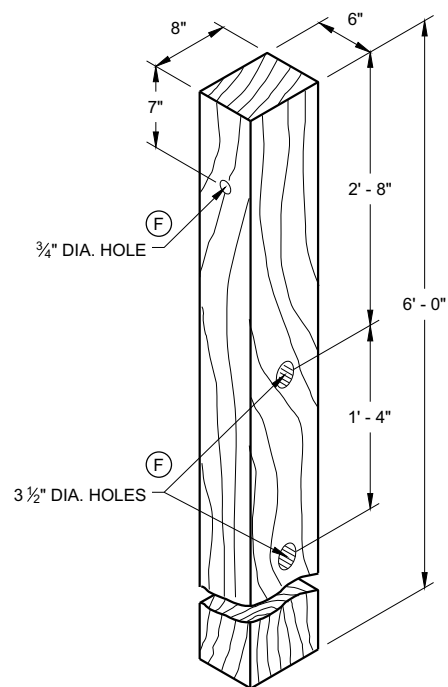

WOOD CRT POST <sup>(3)</sup> (E)  
POSTS NUMBER 3-9

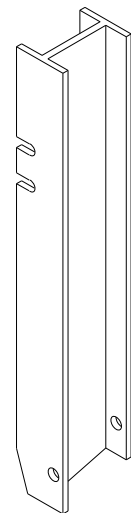

UPPER POST NO. 2 <sup>(15)</sup> (E)

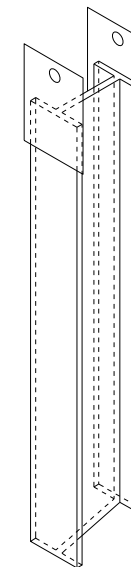

LOWER POST NO. 2 <sup>(16)</sup> (E)

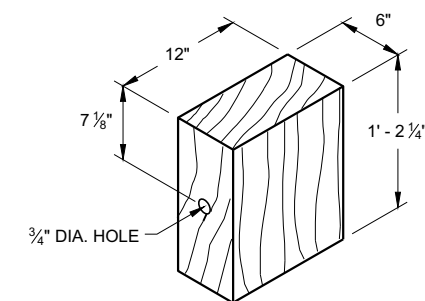

WOOD BLOCKOUT <sup>(4)</sup>  
REQ'D. AT ALL POSTS EXCEPT POST NO'S 1 & 2

6

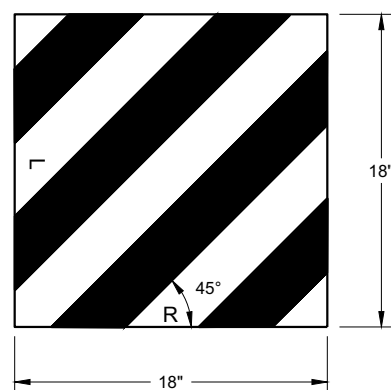

REFLECTIVE SHEETING DETAIL <sup>(E)</sup>

TYPE H  
YELLOW REFLECTIVE  
SHEETING 3" X 9".  
SEE STANDARD  
SPECIFICATION 637.

E.A.T. MARKER  
POST (YELLOW)

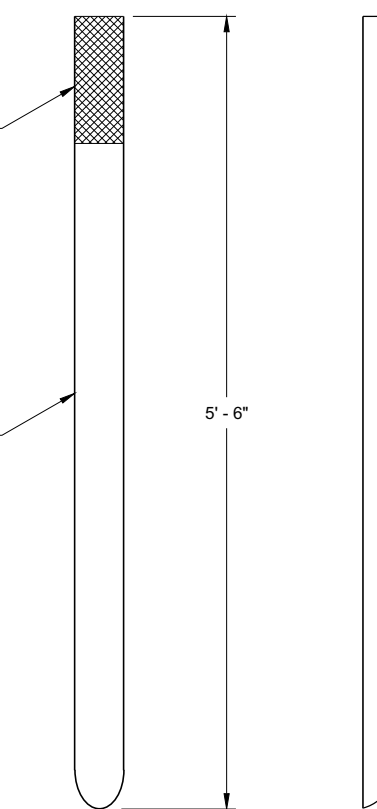

FRONT VIEW SIDE VIEW  
E.A.T. MARKER POST <sup>(13)</sup>

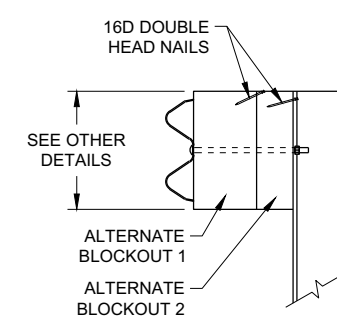

SIDE VIEW

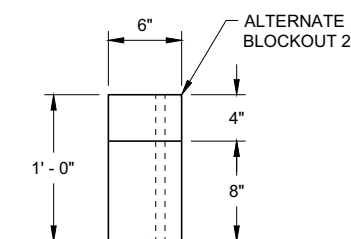

TOP VIEW

ALTERNATE WOOD  
BLOCKOUT DETAIL

6

**MIDWEST GUARDRAIL SYSTEM  
ENERGY ABSORBING TERMINAL  
(MGS)**

STATE OF WISCONSIN  
DEPARTMENT OF TRANSPORTATION

APPROVED  
7/2018 /S/ Rodney Taylor  
DATE ROADWAY STANDARDS DEVELOPMENT  
UNIT SUPERVISOR

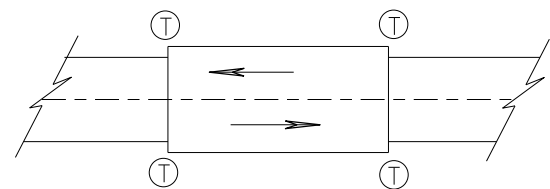

**TWO WAY TRAFFIC**

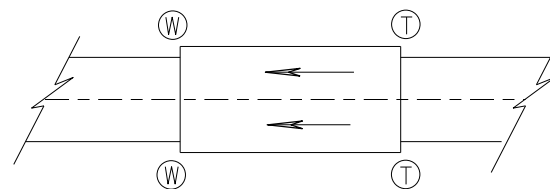

**ONE WAY TRAFFIC**

(T) THRIE BEAM CONNECTION

(W) W-BEAM CONNECTION WHEN REQUIRED

**TYPICAL LOCATIONS OF THRIE BEAM AND W-BEAM CONNECTIONS TO BRIDGE**

**GENERAL NOTES**

IF ROCK IS ENCOUNTERED, REMOVE ROCK TO FULL DEPTH OF POST PLUS 2 1/2", AND 12" DIAMETER AROUND POST. SEE 14B42 FOR MORE DETAILS.

TRANSITION USES STEEL POSTS ONLY.

SEE STANDARD DETAIL DRAWING 14 B 42 FOR MORE INFORMATION.

POST 2 THROUGH 17 USES STEEL POST ONLY

① BRIDGE RAILING TYPE "W" DOES NOT REQUIRE A TERMINAL CONNECTOR.

② OPTIONAL CURB AND GUTTER OR DRAINAGE FEATURE SEE PLAN FOR INFORMATION.

⑬ STEEL OR WOOD POST IS ACCEPTABLE AT POST 1. SEE SDD14B42

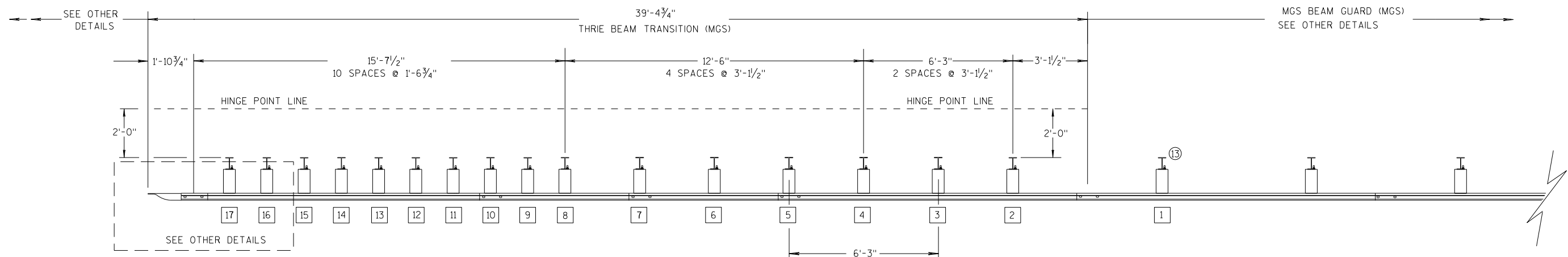

**PLAN VIEW**

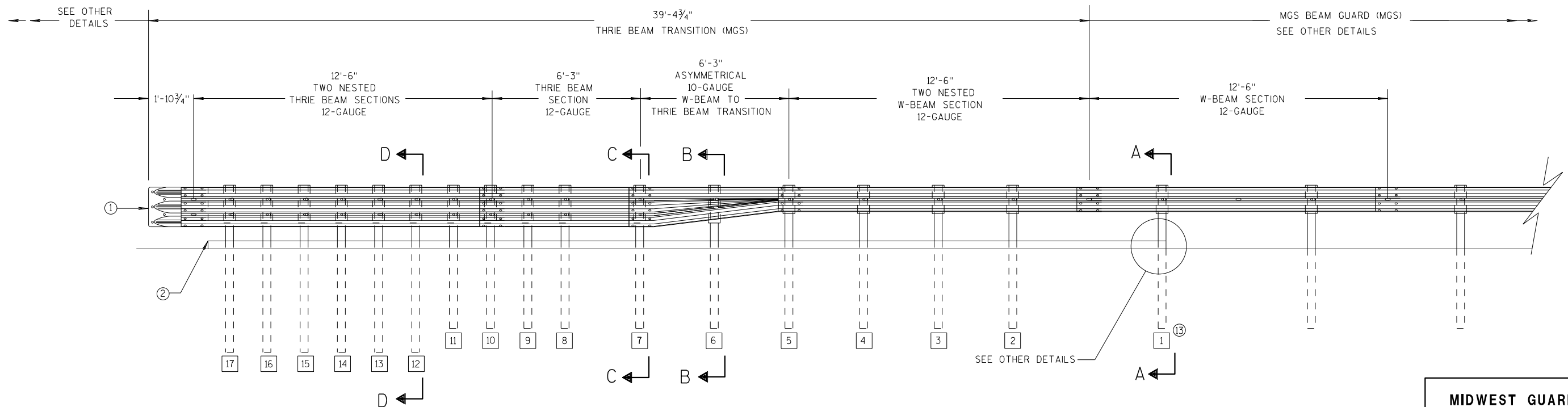

**ELEVATION VIEW**

**MIDWEST GUARDRAIL SYSTEM THRIE BEAM TRANSITION**

**MIDWEST GUARDRAIL SYSTEM  
THRIE BEAM TRANSITION (MGS)**

STATE OF WISCONSIN  
DEPARTMENT OF TRANSPORTATION

**GENERAL NOTES**

- ② OPTIONAL CURB AND GUTTER OR DRAINAGE FEATURE SEE PLAN FOR INFORMATION.
- ③ WHEN USING STEEL POSTS AND WOOD BLOCKOUTS INSTALL FOUR 10D GALVANIZED NAILS. INSTALL NAILS AT THE BACK CORNERS OF THE BLOCK AND BEND THE NAILS OVER THE FLANGE OF THE STEEL POST.
- ④ TOLERANCE FOR TOP OF W-BEAM RAIL IS ± 1".
- ⑬ STEEL OR WOOD POST IS ACCEPTABLE AT POST 1. SEE SDD 14B42

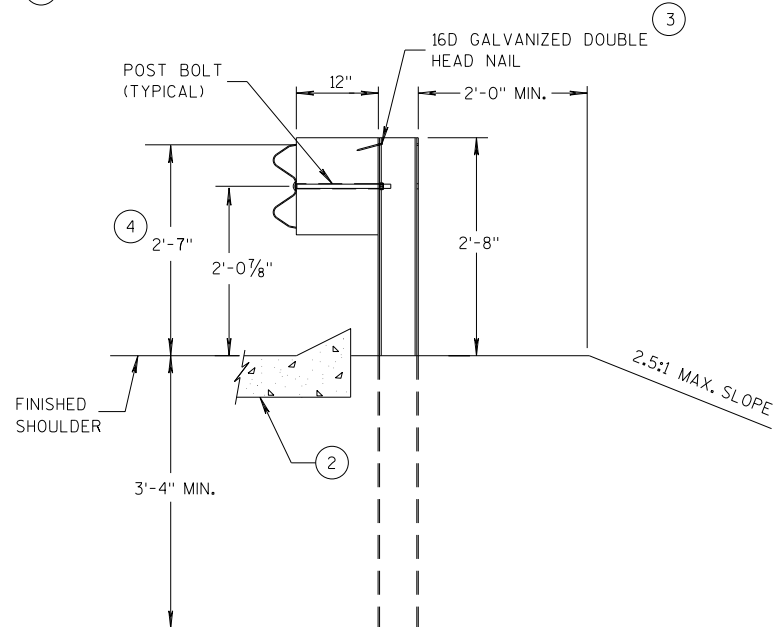

**SECTION A-A  
POSTS 1-5**

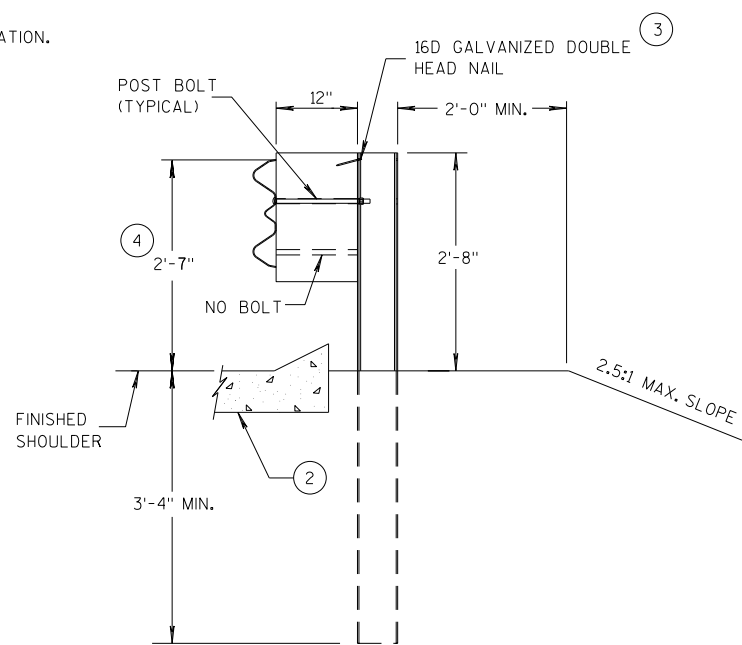

**SECTION B-B  
POST 6**

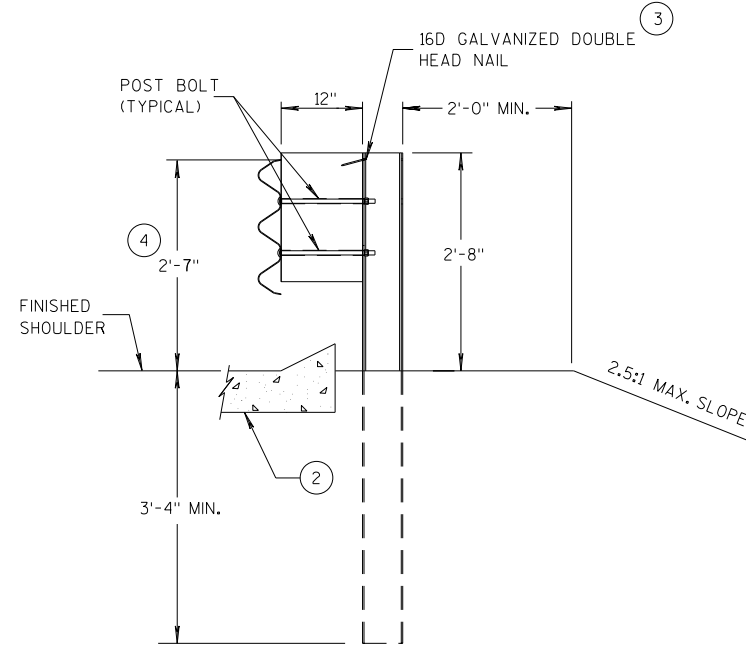

**SECTION C-C  
POSTS 7-11**

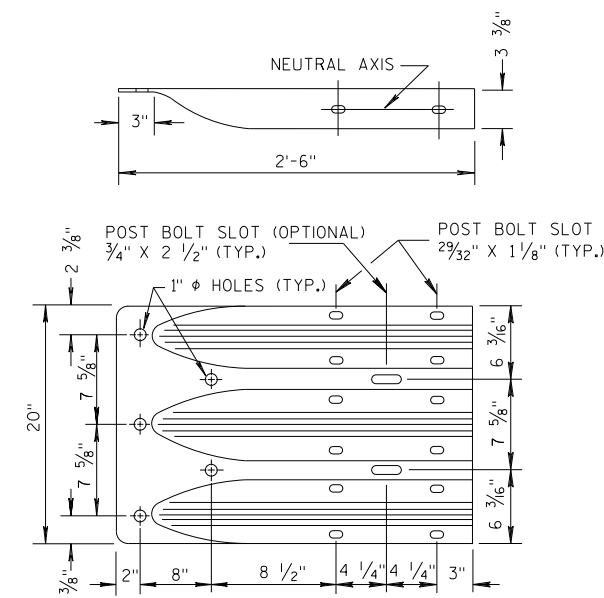

**THRIE BEAM  
TERMINAL CONNECTOR**

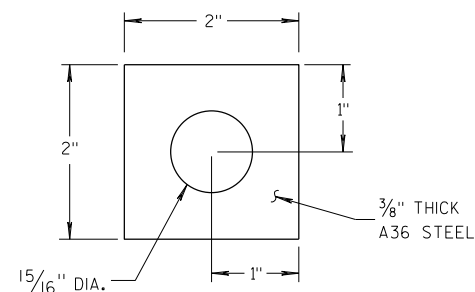

**PLATE WASHER DETAIL**

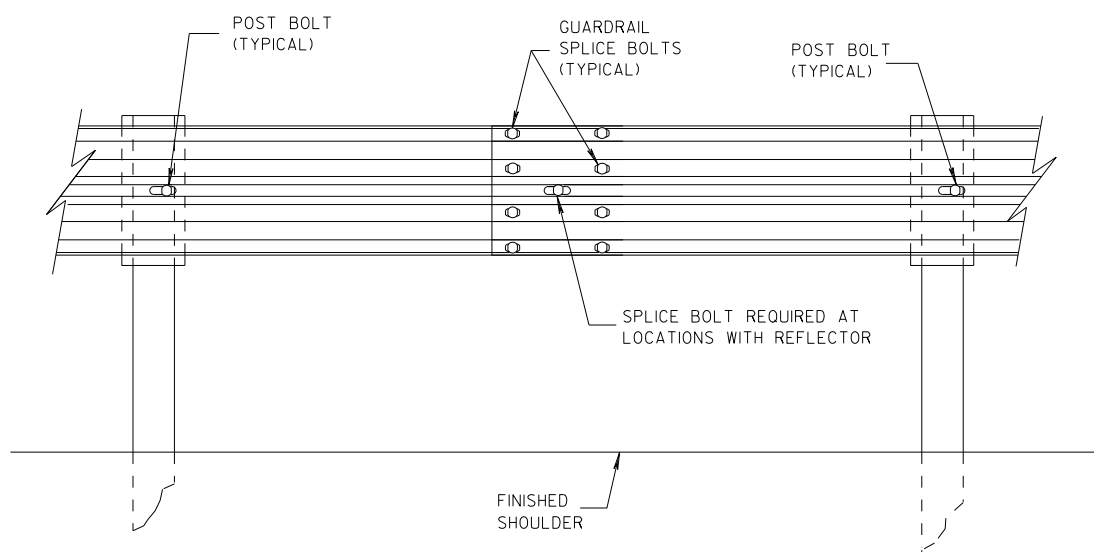

**SPLICE DETAIL**

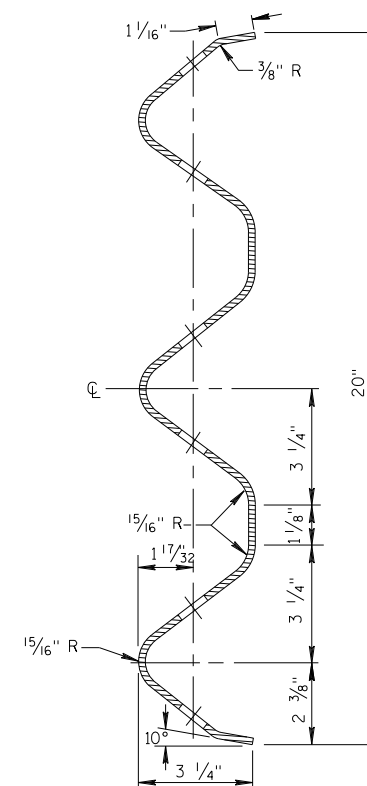

**SECTION THRU THRIE  
BEAM RAIL ELEMENT**

**MIDWEST GUARDRAIL SYSTEM  
THRIE BEAM TRANSITION (MGS)**

STATE OF WISCONSIN  
DEPARTMENT OF TRANSPORTATION



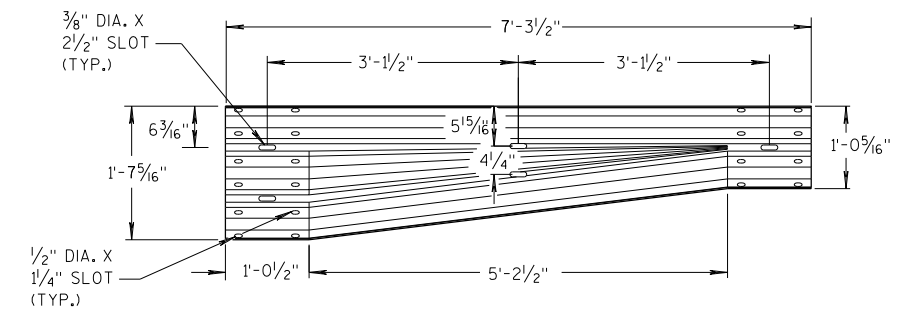

**W-BEAM TO THRIE BEAM TRANSITION SECTION**

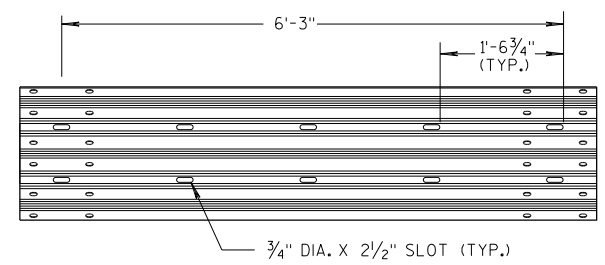

**6'-3\"/>**

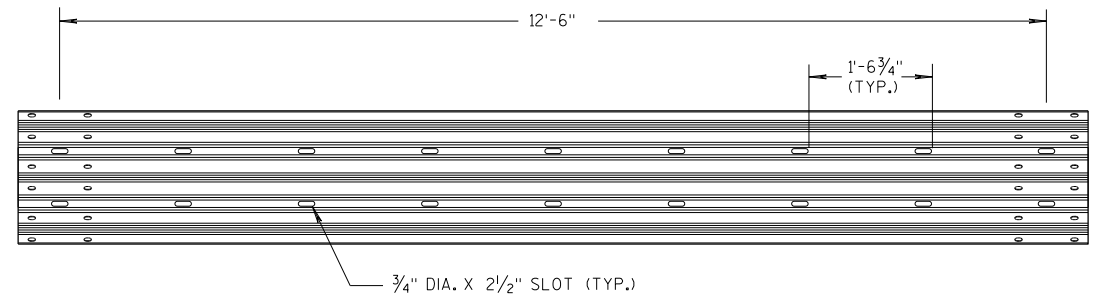

**12'-6\"/>**

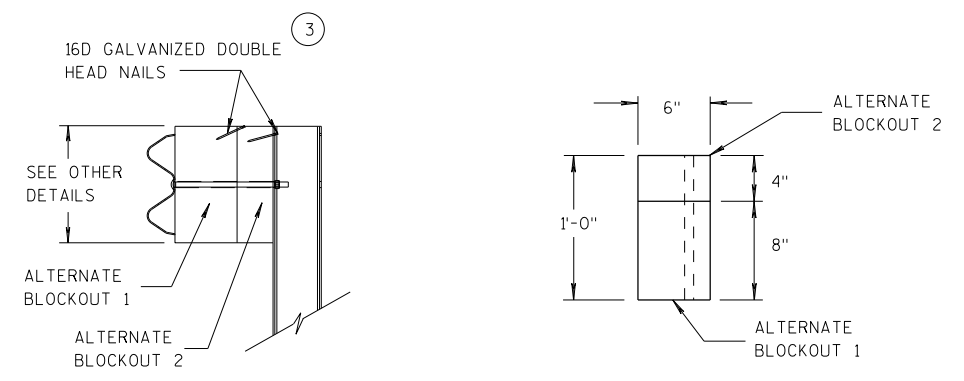

**ALTERNATE WOOD BLOCKOUT DETAIL**

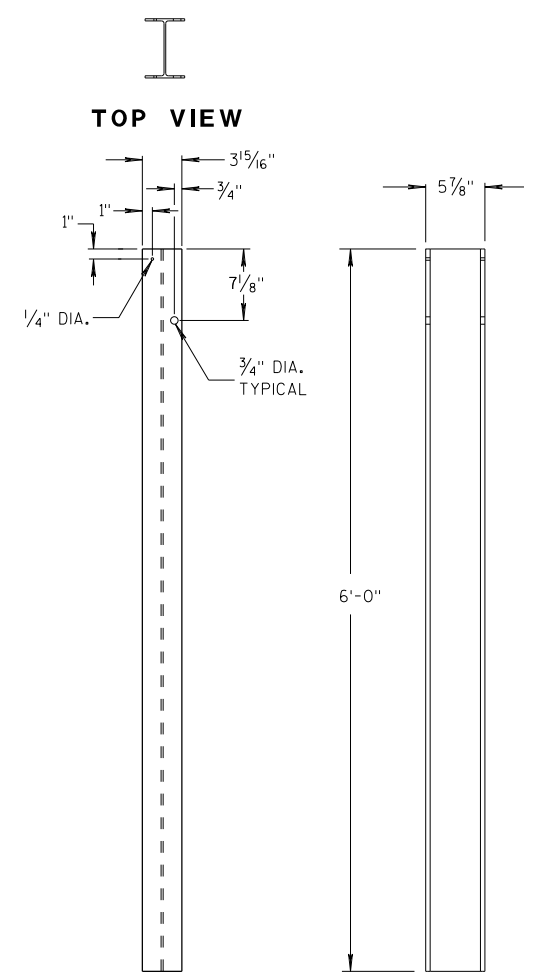

**STEEL POSTS 1-5**

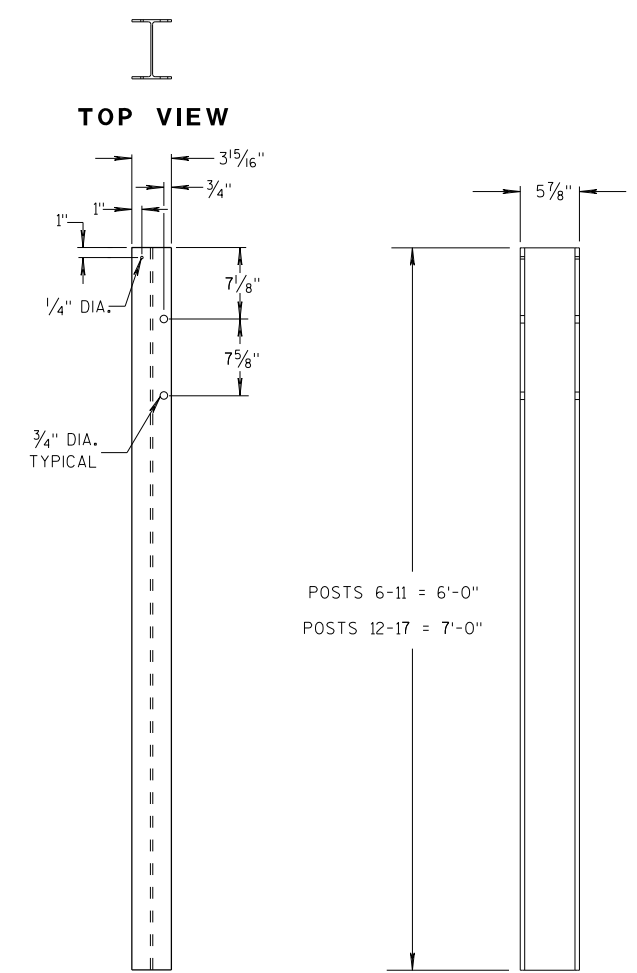

**STEEL POSTS 6-17**

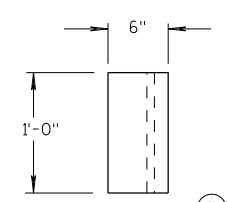

**TOP VIEW**

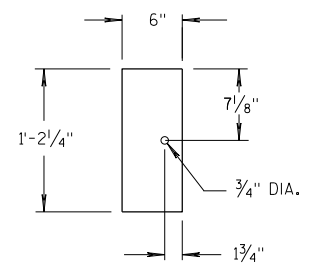

**FRONT VIEW  
BLOCKOUT  
POSTS 1-5**

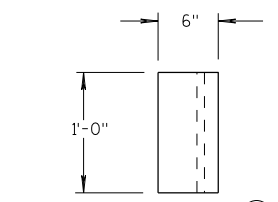

**TOP VIEW**

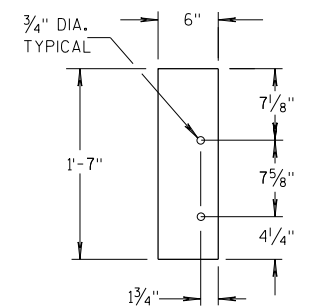

**FRONT VIEW  
BLOCKOUT  
POSTS 6-17**

**GENERAL NOTES**

- STEEL POSTS ARE W6X9 OR W6X8.5.
- BOLT HOLES FOR POST ARE ON FRONT AND OF SIDE OF POST.
- (3) WHEN USING STEEL POSTS AND WOOD BLOCKOUTS INSTALL FOUR 16D GALVANIZED NAILS. INSTALL NAILS AT THE BACK CORNERS OF THE BLOCK AND BEND THE NAILS OVER THE FLANGE OF THE STEEL POST.
- (5) WOOD BLOCKS MAY BE CONSTRUCTED OUT OF 2 WOOD BLOCKS. SEE ALTERNATE WOOD BLOCK DETAIL.
- (13) STEEL OR WOOD POST IS ACCEPTABLE AT POST 1. SEE SDD 14B42.

**MIDWEST GUARDRAIL SYSTEM  
THRIE BEAM TRANSITION (MGS)**

STATE OF WISCONSIN  
DEPARTMENT OF TRANSPORTATION

6

6

S.D.D. 14 B 45-5c

S.D.D. 14 B 45-5c

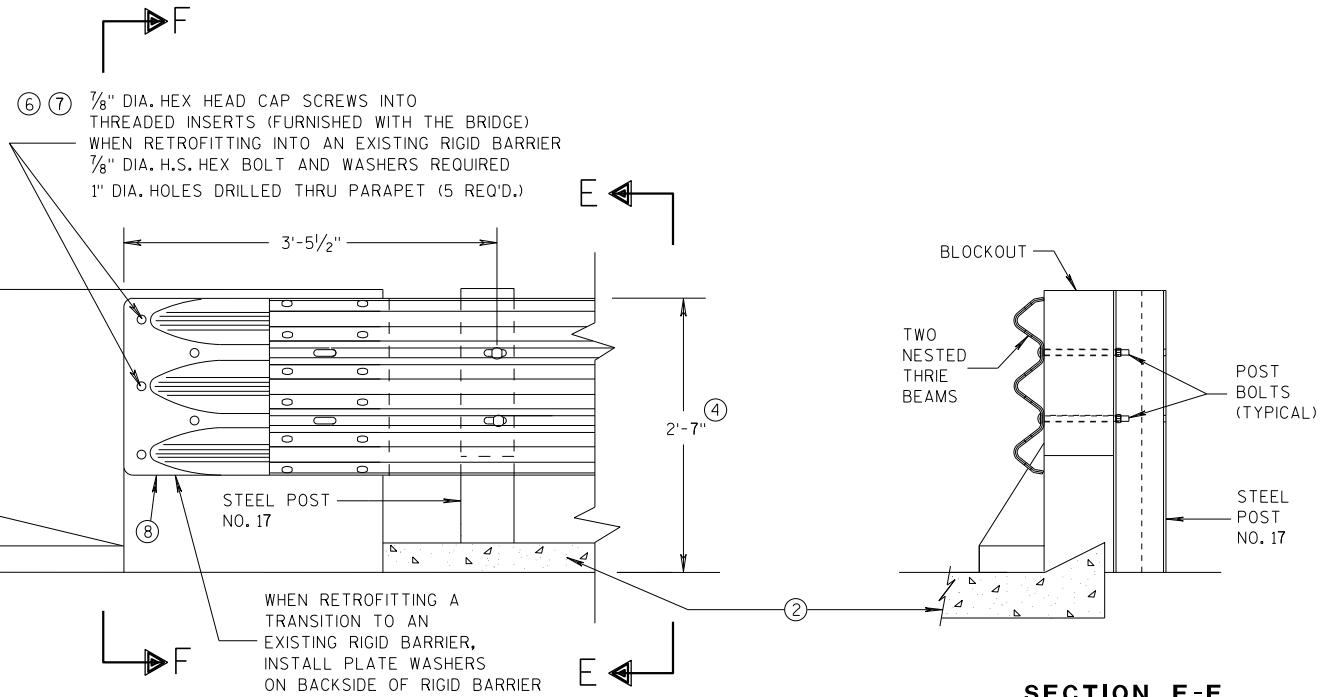

FRONT VIEW

**THRIE BEAM CONNECTION TO BRIDGE PARAPET WITH SQUARE ENDS**

SECTION E-E

**GENERAL NOTES**

- THESE ARE TYPICAL CONNECTION DETAILS. ADJUST THE POSITION OF CONNECTIONS TO EXISTING BRIDGES TO FIT THE ACTUAL BRIDGE AND SITE DIMENSIONS.
- (2) OPTIONAL CURB AND GUTTER OR DRAINAGE FEATURE SEE PLAN FOR INFORMATION.
- (4) TOLERANCE FOR TOP OF BEAM IS  $\pm 1$ ".
- (6) DRILLING BOLT HOLES THROUGH THE PARAPET, BOLTS, NUTS, WASHERS AND REPAIRING DAMAGED CONCRETE ARE INCIDENTAL TO THE CONTRACT.
- (7) BOLTS MAY BE A325 BOLTS OR A449 BOLTS. BOLT LENGTH AND THREADING LENGTH ARE TO ALLOW FOR A TIGHT CONNECTION BETWEEN RIGID BARRIER AND THRIE BEAM CONNECTION PLATE. CONTRACTOR IS TO FIELD VERIFY BOLT LENGTH AND THREAD LENGTH. ONE ROUND WASHER REQUIRED BETWEEN BOLT HEAD AND THRIE BEAM CONNECTOR PLATE. BOLTS THAT EXTEND THROUGH THE PARAPET AND OUT THE BACK FACE REQUIRE A HARDENED ROUND STEEL WASHER THAT IS 2" O.D. X 5/32" THICK AND ONE PLATE WASHER. REPAIR ANY DAMAGED CONCRETE FROM BOLT INSTALLATION.
- (8) THE RECESS FOR A W-BEAM CONNECTION, WHICH EXISTS ON SOME PARAPETS OF THIS TYPE, SHALL BE FILLED WITH A TREATED TIMBER BLOCKOUT. BLOCKOUT SIZE IS 1'-6" X 2'-0" X 3 1/2".

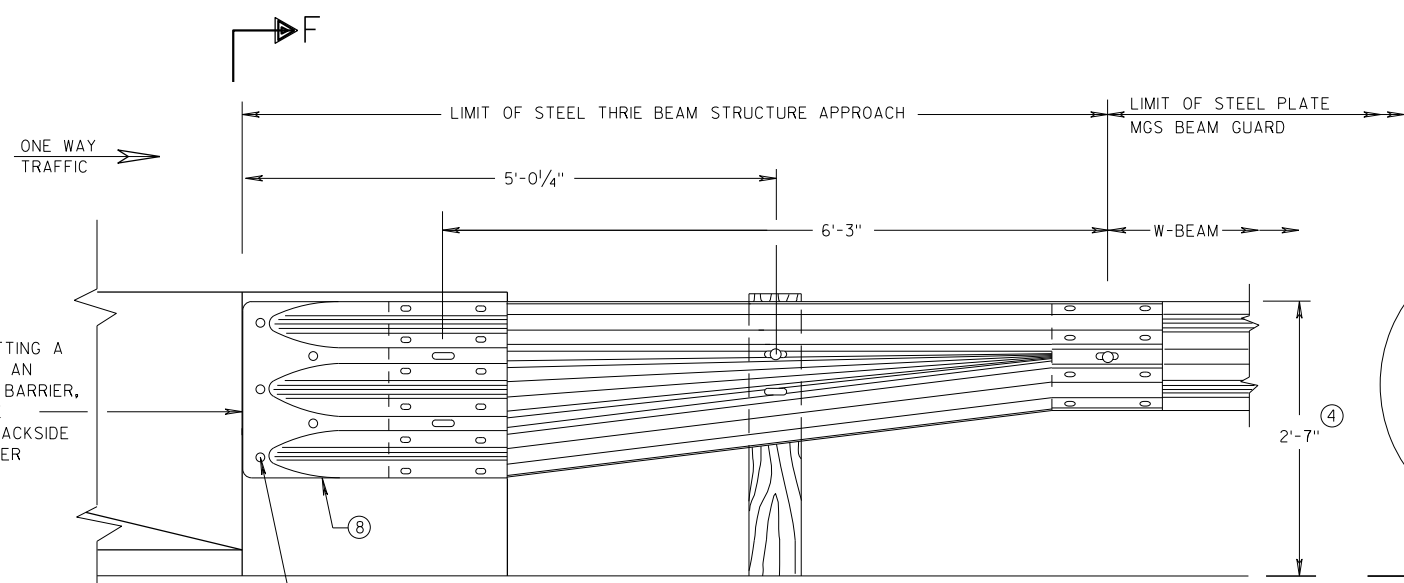
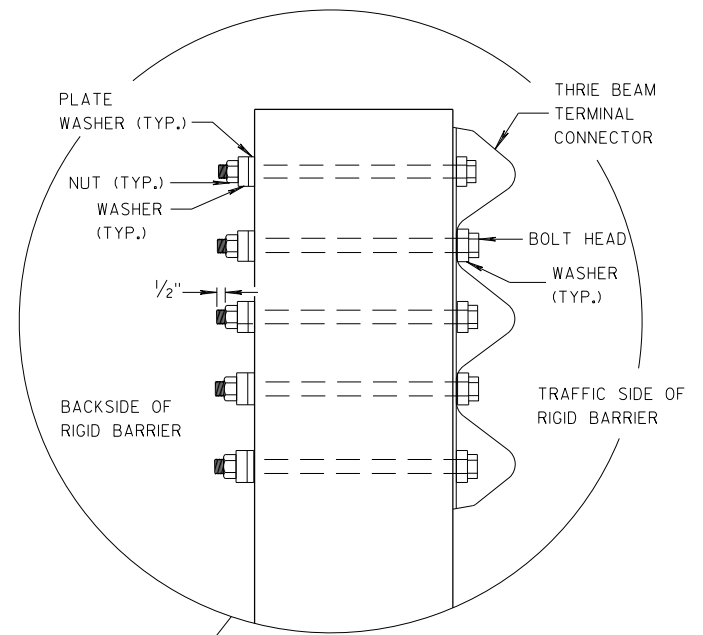

FRONT VIEW

**W BEAM TRANSITION AND CONNECTION TO BRIDGE PARAPETS WITH SQUARE ENDS  
(USE ONLY ON THE TRAFFIC EXIT END OF ONE WAY BRIDGES)**

SECTION F-F

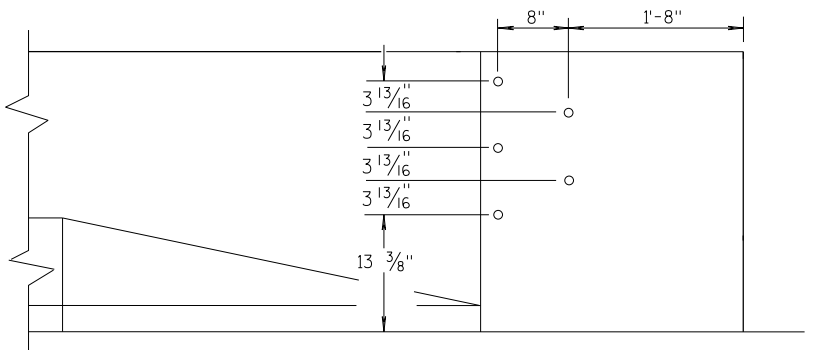

DRILL HOLE LOCATION

**MIDWEST GUARDRAIL SYSTEM  
THRIE BEAM TRANSITION (MGS)**

STATE OF WISCONSIN  
DEPARTMENT OF TRANSPORTATION

APPROVED  
DATE 07/2018 /S/ Rodney Taylor  
ROADWAY STANDARDS DEVELOPMENT  
UNIT SUPERVISOR  
FHWA

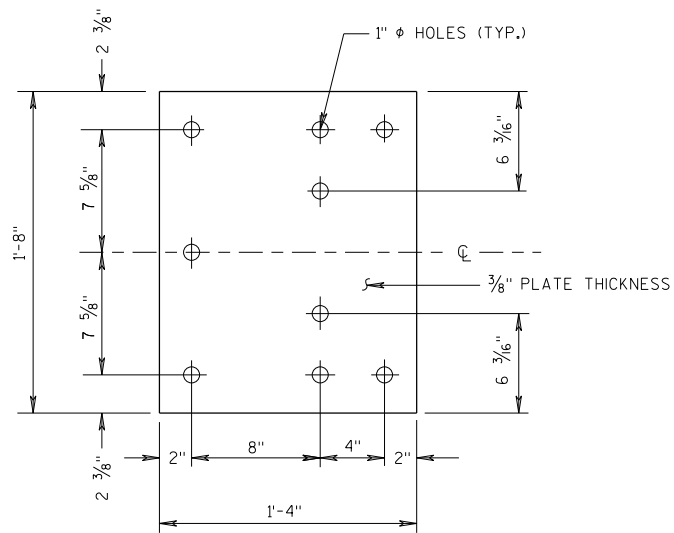

**BACK-UP PLATE DETAIL**

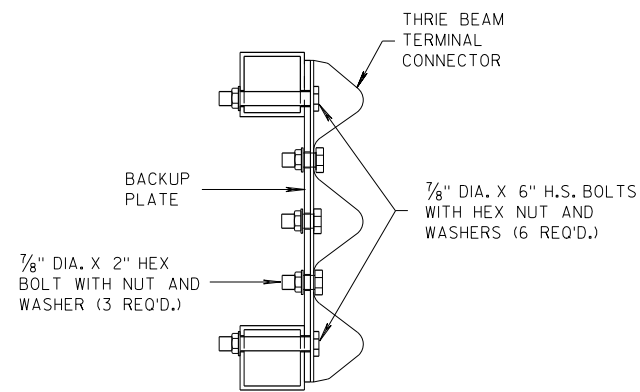

**SECTION J-J**

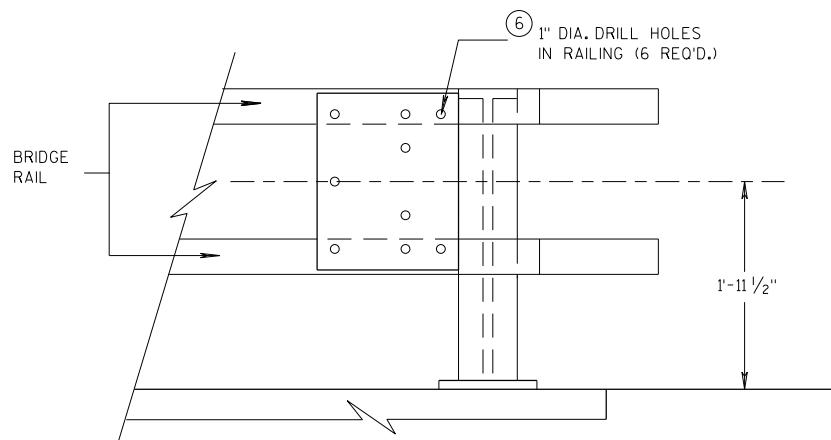

**BACK-UP PLATE MOUNTING ONTO BRIDGE RAILING**

**GENERAL NOTES**

- ④ TOLERANCE FOR TOP OF BEAM IS  $\pm 1'$ .
- ⑥ DRILLING HOLES THROUGH THE PAPER, BOLTS, NUTS, WASHERS AND REPAIRING DAMAGED CONCRETE ARE INCIDENTAL TO THE CONTRACT.

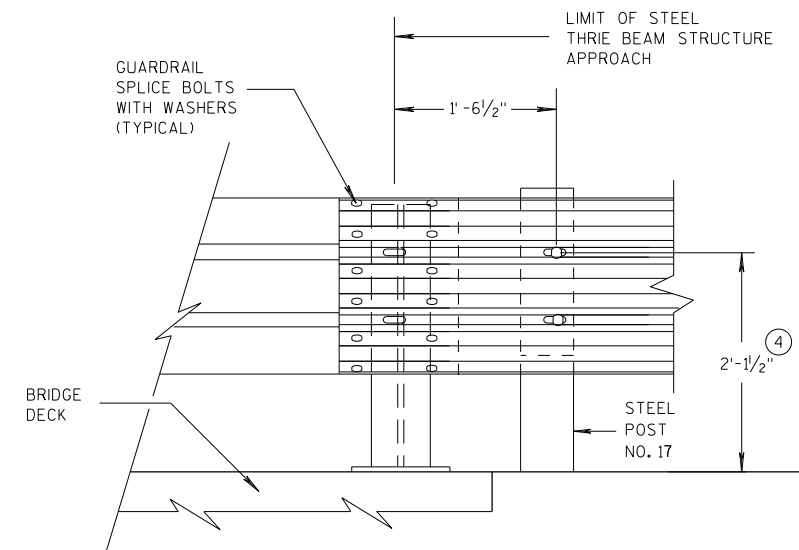

**FRONT VIEW THRIE BEAM CONNECTION TO STEEL RAILING TYPE "W"**

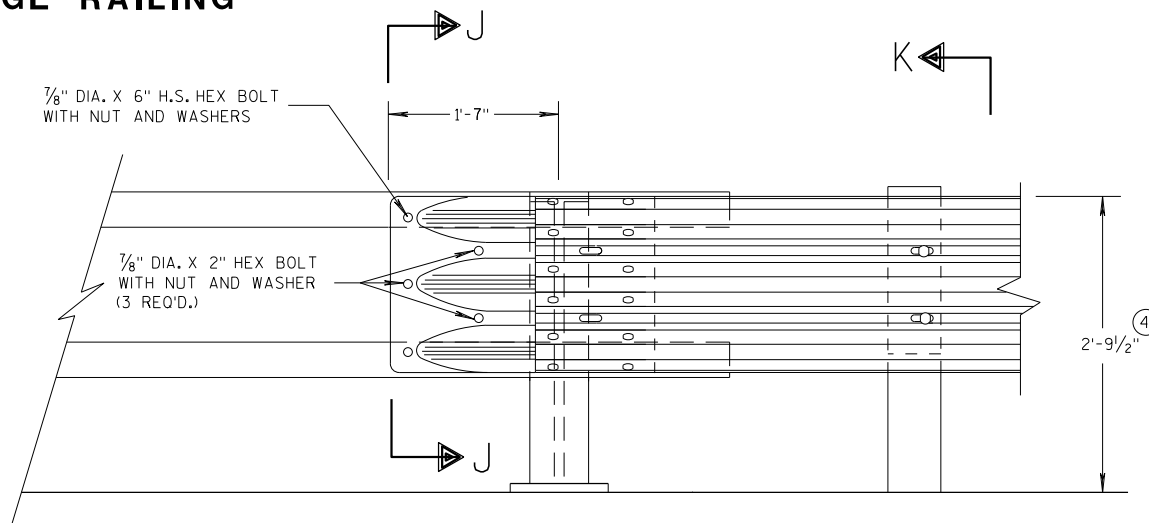

**FRONT VIEW**

**THRIE BEAM CONNECTION TO TUBULAR RAILING TYPE "F"**

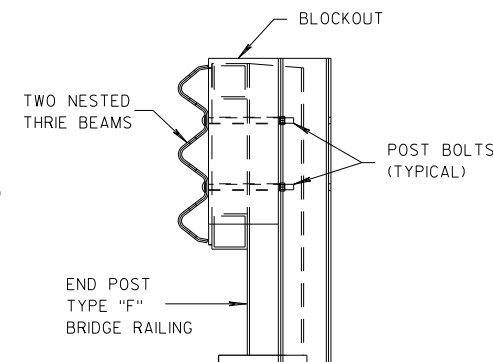

**SECTION K-K**

<b>MIDWEST GUARDRAIL SYSTEM THRIE BEAM TRANSITION (MGS)</b>	
STATE OF WISCONSIN DEPARTMENT OF TRANSPORTATION	
APPROVED 07/2018 DATE	/S/ Rodney Taylor ROADWAY STANDARDS DEVELOPMENT UNIT SUPERVISOR
FHWA	

6

6

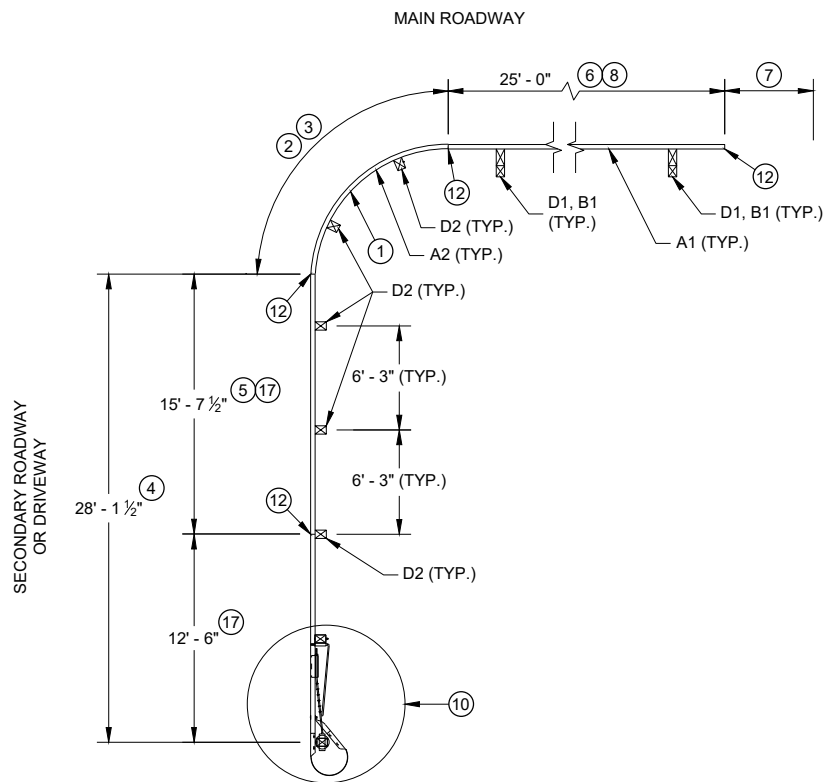

**PLAN VIEW**  
**SHORT RADIUS BEAM GUARD WITH**  
**SHORT RADIUS TERMINAL ON**  
**SECONDARY ROAD OR DRIVEWAY**

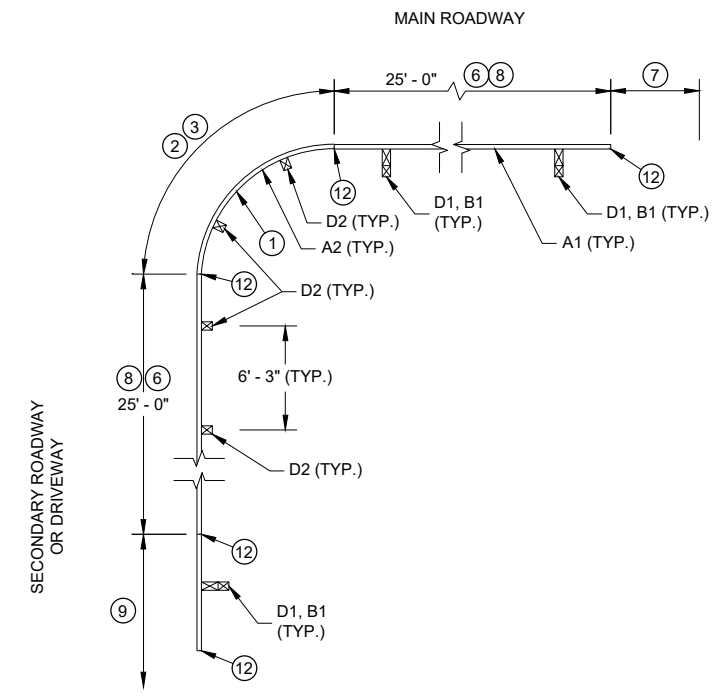

**PLAN VIEW**  
**SHORT RADIUS BEAM GUARD WITH**  
**EAT, ADDITIONAL BEAM GUARD**  
**OR**  
**TRANSITION TO RIGID BARRIER ON**  
**SECONDARY ROAD OR DRIVEWAY**

**TABLE FOR RADIUS OF 32' AND LESS**

RADIUS (FT)	LENGTH (FT)	WIDTH (FT)
8	25	15
16	30	15
24	40	20
32	50	30

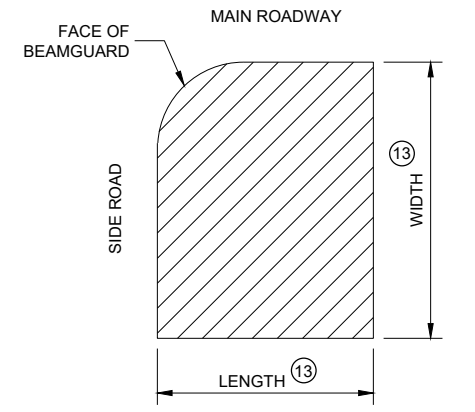

**AREA FREE OF FIXED**  
**OBJECTS FOR RADIUS**  
**32' AND LESS**

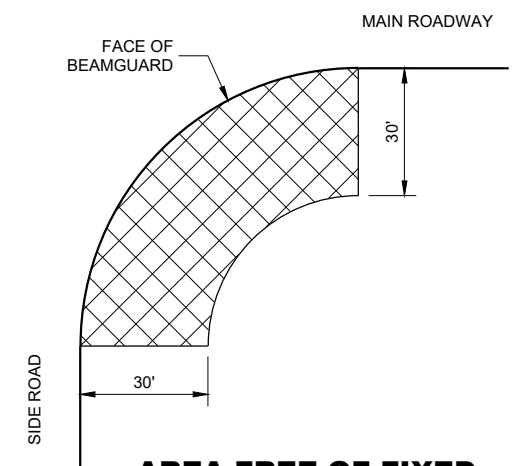

**AREA FREE OF FIXED**  
**OBJECTS FOR RADIUS**  
**GREATER THAN 32'**

**GENERAL NOTES**

- SEE PLANS FOR OTHER BARRIER SYSTEM AND LOCATION SPECIFICS.
- SEE SDD 14B42 FOR MORE INFORMATION ON BEAM GUARD INSTALLATION, PARTS, MATERIALS, AND INSTALLATION INFORMATION.
- GALVANIZE PARTS AFTER FABRICATION.
- WELDING TO FOLLOW CURRENT REQUIREMENTS OF THE AMERICAN WELDING SOCIETY STRUCTURAL WELDING CODE ANSI / AWS D1.1.
- UNLESS NOTED OTHERWISE, ALL PLATES ARE FLAT AND FREE OF WARP.
- UNLESS NOTED OTHERWISE, ALL EDGES ARE SMOOTH, STRAIGHT AND VERTICAL.
- ALL CUTS AND HOLES, EXCEPT IN BEAM GUARD RAIL ARE TO BE MACHINED OR MACHINE FLAME CUT.
- UNLESS NOTED OTHERWISE, CUT OR PROVIDE BOLTS THAT ARE 1/4" TO 1/2" BEYOND THE NUT.
- DRAWINGS ARE NOT TO SCALE.

- ① RADIUS MEASURE FROM INSIDE OF RAIL. LENGTH OF BEAM GUARD SHORT RADIUS GUARD MEASURED ALONG TRAFFIC SIDE OF RAIL. RADIUS BETWEEN 8 FEET TO 150 FEET. SEE PLAN FOR REQUIRED RADIUS. BEAM GUARD RAIL IN RADIUS IS SHOP BENT. ODD RAIL LENGTH OR FIELD CUTS MAY BE REQUIRED.
- ② CONTROLLED RELEASE TERMINAL (CRT) POSTS ARE USED IN THE RADIUS. CONTROLLED RELEASE TERMINAL (CRT) POSTS ARE SPACED 6' - 3". SEE PLAN FOR NUMBER OF CONTROLLED RELEASE (CRT) POSTS.
- ③ WITHIN RADIUS BEAM GUARD RAILS ARE NOT BOLTED TO POSTS. BEAM GUARD RAIL IS RESTED ON TOP OF LAG SCREW.
- ④ MINIMUM LENGTH OF BEAM GUARD ALONG SIDE ROAD OR DRIVEWAY TO INSTALL SHORT RADIUS TERMINAL. BEAM GUARD IS PAID WITH BEAM GUARD ITEM.
- ⑤ ODD LENGTH OF BEAM GUARD REQUIRED TO INSTALL SHORT RADIUS TERMINAL.
- ⑥ MINIMUM AMOUNT OF BEAM GUARD TO BE INSTALLED PRIOR TO TRANSITION TO RIGID BARRIER, ADDITIONAL BEAM GUARD, OR EAT. BEAM GUARD PAID FOR WITH BEAM GUARD ITEM. SEE PLANS FOR MORE DETAIL.
- ⑦ BEAM GUARD, EAT, OR TRANSITION TO RIGID BARRIER. SEE PLAN.
- ⑧ TOP OF BEAM GUARD BY THE RADIUS IS 27". HEIGHT OF BEAM GUARD IS 31" BY TRANSITION TO RIGID BARRIER, ADDITIONAL BEAM GUARD OR EAT.
- ⑨ ADDITIONAL BEAM GUARD, EAT OR TRANSITION TO RIGID BARRIER. BEAM GUARD SHOWN. SEE PLAN FOR DETAILS.
- ⑩ SHORT RADIUS TERMINAL (SEE OTHER DETAILS).
- ⑪ HEIGHT VARIES. SEE NOTE ⑧ AND ⑧.
- ⑫ BEAM GUARD RAIL SPLICE LOCATION. SPLICE LOCATION REQUIRES PART F1 AND F2. SEE SDD 14B42 FOR DETAILS.
- ⑬ SEE TABLE FOR VALUES.
- ⑭ MAXIMUM HEIGHT FOR CENTER OF HOLE IS 3/4" ABOVE FINISHED GROUND ±1".
- ⑮ DRILL POST 1 5/8" DIA. PILOT HOLE. DO NOT HAMMER LAG SCREW INTO POST.
- ⑯ SMALL SIGNS ON BREAKAWAY HARDWARE ARE ACCEPTABLE.
- ⑰ TOP OF RAIL HEIGHT IS 27" WHEN USING A SHORT RADIUS TERMINAL (CRT).

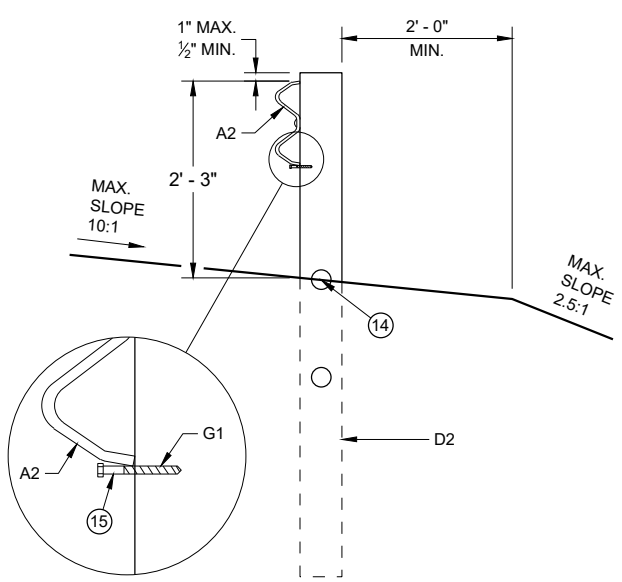

**CONTROLLED RELEASE**  
**TERMINAL POST (CRT) IN RADIUS**

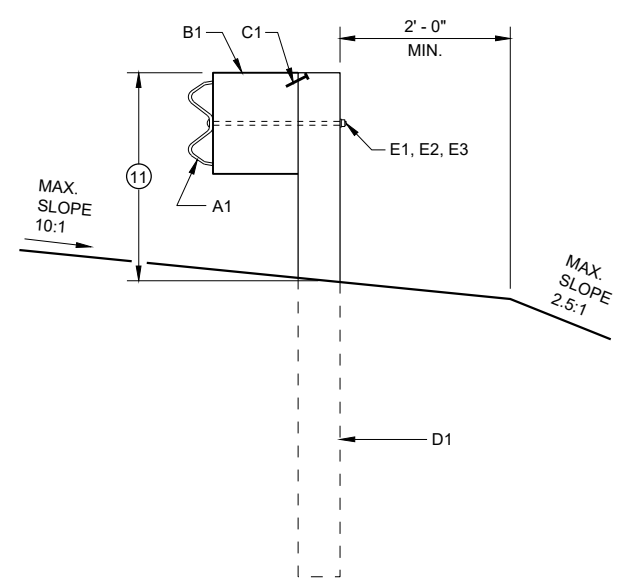

**BEAM GUARD POSTS**  
**IN HEIGHT TRANSITION**

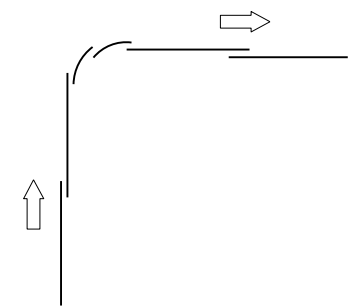

**LAP SPLICE DETAIL**

**SHORT RADIUS BEAM GUARD (MGS) SHORT RADIUS TERMINAL (MGS)**

STATE OF WISCONSIN  
 DEPARTMENT OF TRANSPORTATION

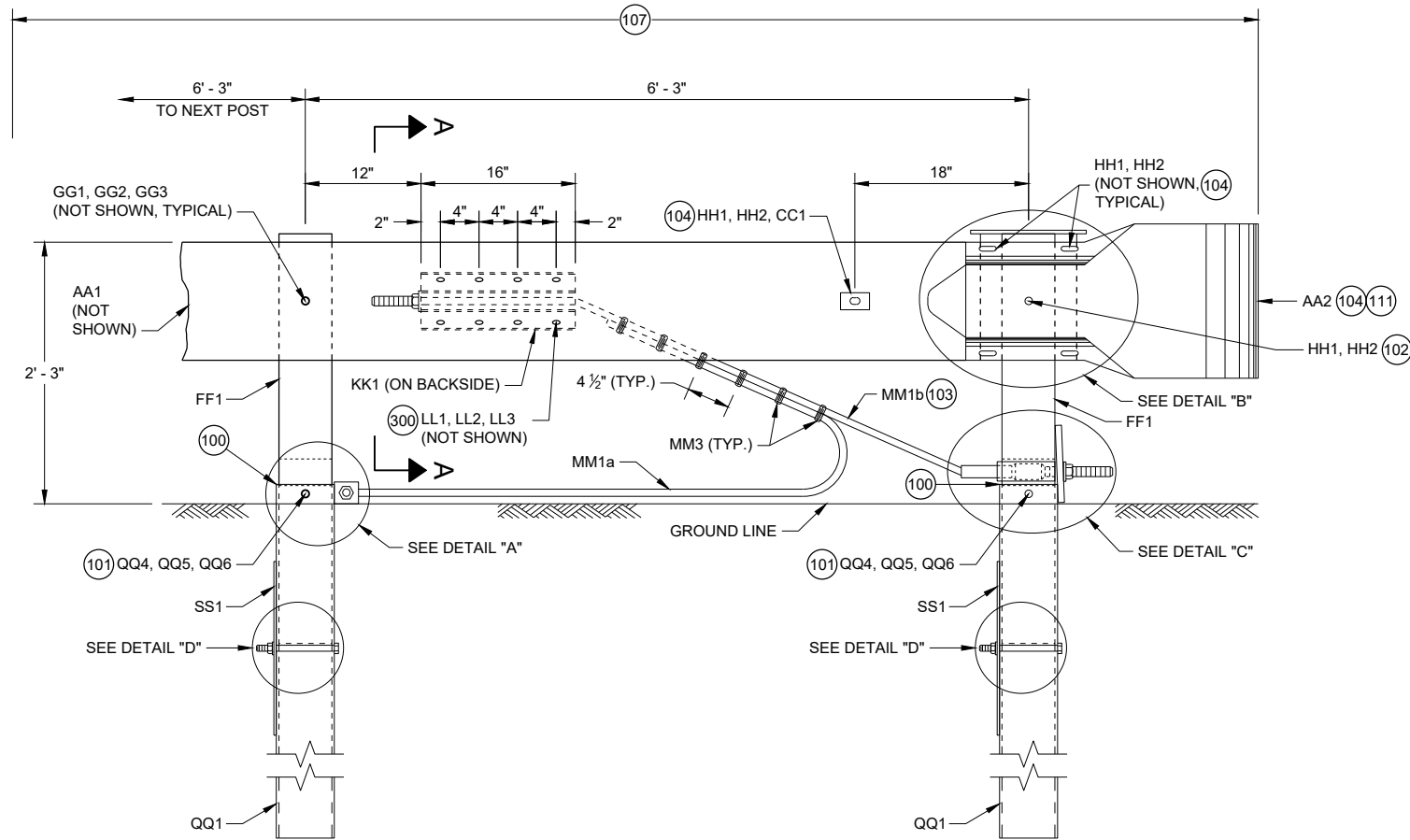

**PROFILE VIEW  
SHORT RADIUS TERMINAL**

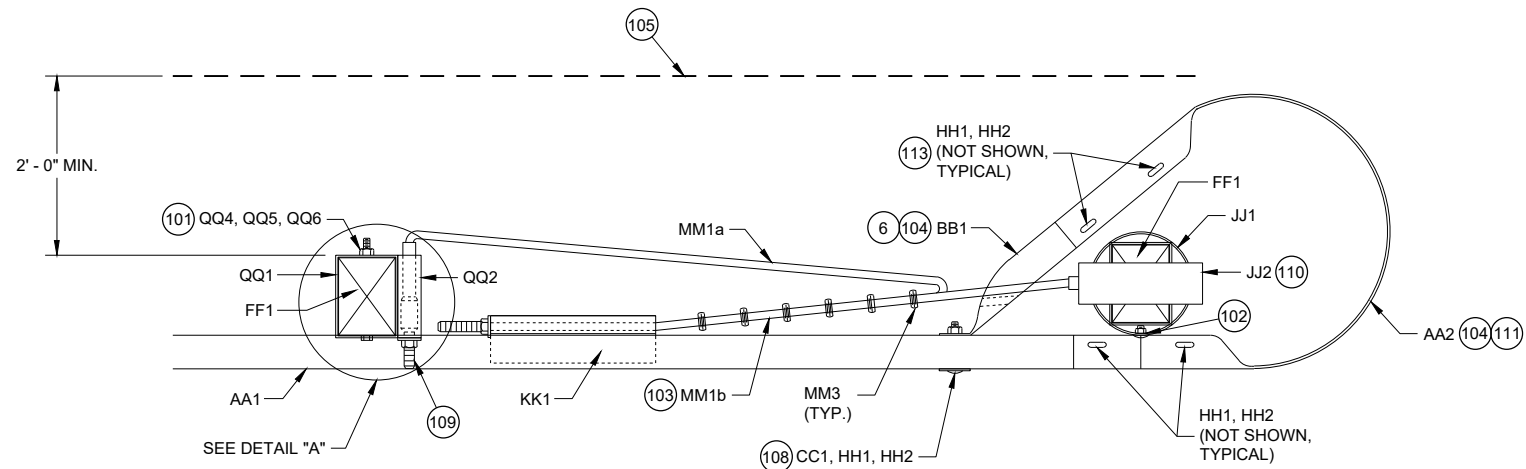

**TOP VIEW  
SHORT RADIUS TERMINAL**

**GENERAL NOTES**

- (100) TOP OF FOUNDATION TUBE 2 INCHES MAXIMUM ABOVE FINISHED GROUND.
- (101) WASHERS REQUIRED BETWEEN BOLT HEAD AND FOUNDATION TUBE AND BETWEEN NUT AND FOUNDATION TUBE.
- (102) SPLICE BOLT AND NUT CONNECTS BEAM GUARD RAIL, W-BEAM SECTION BUFFER, AND STEEL PIPE ASSEMBLY. NO WASHER REQUIRED. SEE DETAIL "B".
- (103) CABLE IS TAUT.
- (104) ADJUST AA2 AND BB1 TO FIT.
- (105) BREAK POINT OF SHOULDER.
- (106) TACK WELD CABLE CONNECTOR TUBE PLATE TO CABLE CONNECTION TUBE. SEE DETAIL "A" PROFILE VIEW.
- (107) PAY LIMIT FOR BEAM GUARD.
- (108) SQUARE WASHER BETWEEN HEAD OF BOLT AND TRAFFIC FACE OF BEAM GUARD. ROUND WASHER REQUIRED BETWEEN NUT AND BB1.
- (109) CUT OR PROVIDE THREADED STUD THAT IS FLUSH WITH FACE OF BEAM GUARD RAIL KK1 (PLUS OR MINUS 1/2" TOLERANCE). DEBURR AFTER CUTTING.
- (110) SEE STEEL PIPE ASSEMBLY DETAILS.
- (111) ATTACH UU2 WITH UU3. SHOP APPLY UU1 TO UU2.
- (112) FOUR (4) HH1 AND HH2 REQUIRED TO ATTACH AA1 TO AA2.
- (113) FOUR (4) HH1 AND HH2 REQUIRED TO ATTACH AA2 TO BB1.

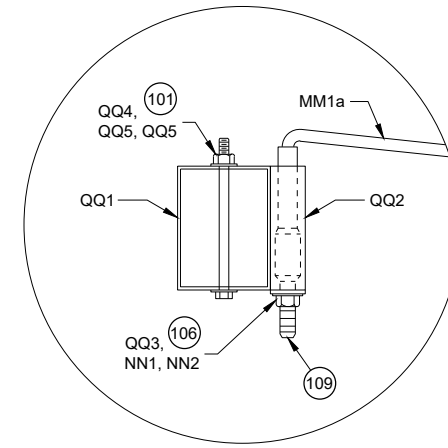

**TOP VIEW  
DETAIL "A"  
(WOOD BREAKAWAY AND BEAM  
GUARD RAIL POSTS NOT SHOWN)**

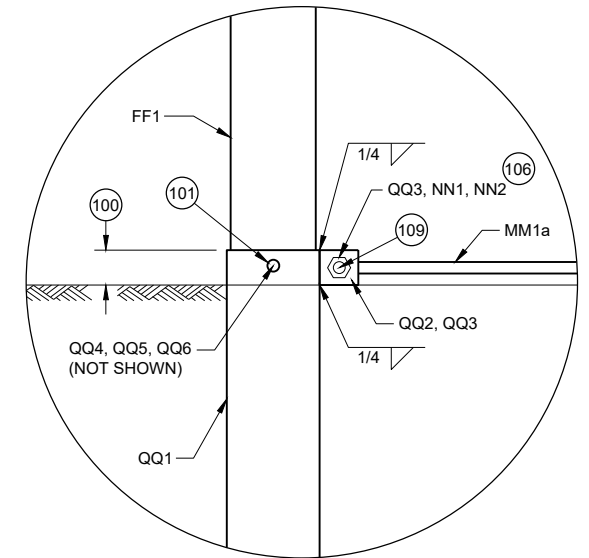

**PROFILE VIEW  
DETAIL "A"**

**SHORT RADIUS BEAM  
GUARD (MGS) SHORT  
RADIUS TERMINAL (MGS)**

STATE OF WISCONSIN  
DEPARTMENT OF TRANSPORTATION

**GENERAL NOTES**

(200) TWO (2) NAILS SPACED 4 INCHES CENTER TO CENTER.

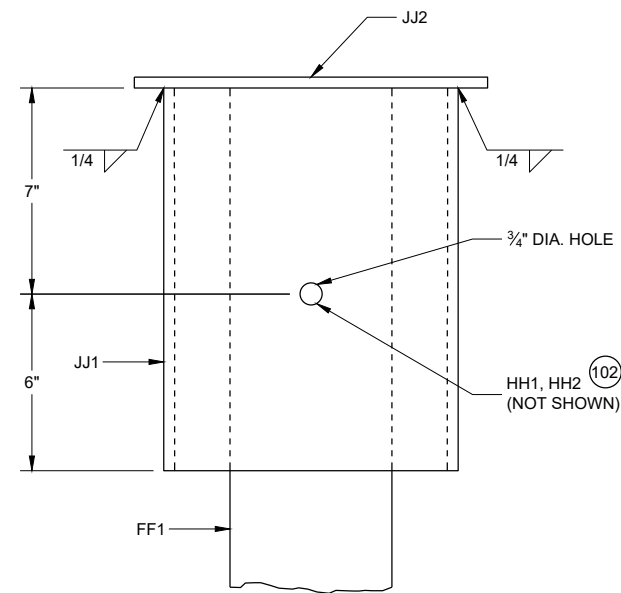

**PROFILE VIEW  
DETAIL "B"  
STEEL PIPE ASSEMBLY  
(BEAM GUARD AND W BEAM  
END SECTION NOT SHOWN)**

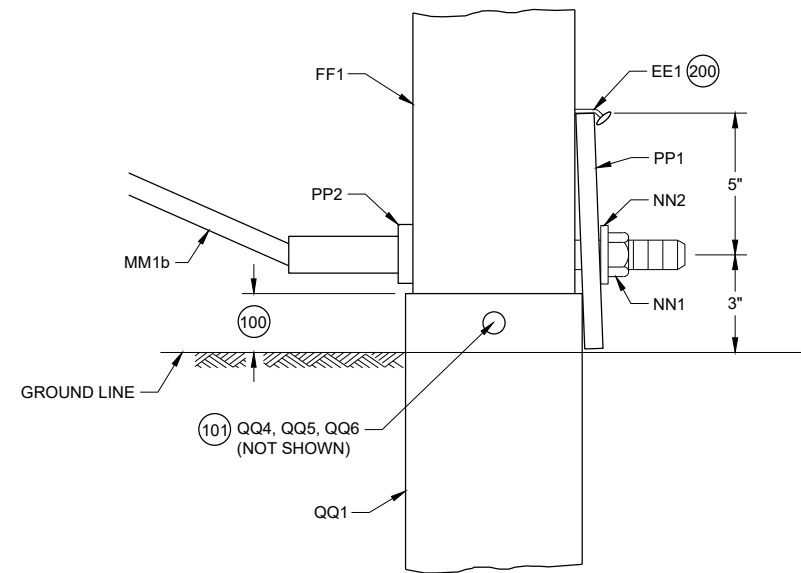

**PROFILE VIEW  
DETAIL "C"**

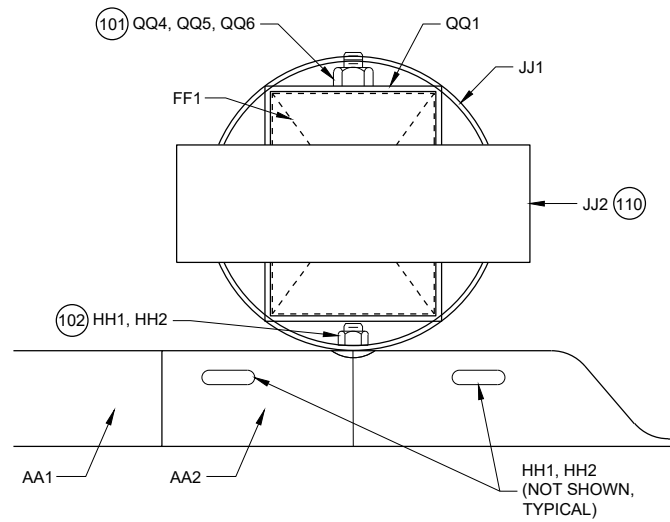

**PLAN VIEW  
DETAIL "B"  
STEEL PIPE ASSEMBLY**

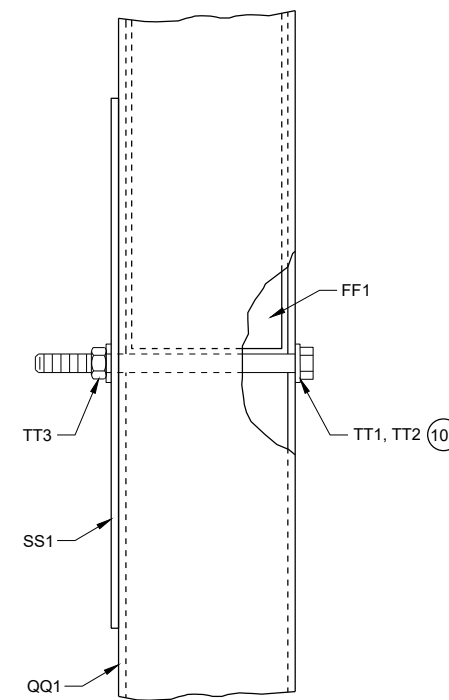

**PROFILE VIEW  
DETAIL "D"**

**SHORT RADIUS BEAM  
GUARD (MGS) SHORT  
RADIUS TERMINAL (MGS)**

STATE OF WISCONSIN  
DEPARTMENT OF TRANSPORTATION

**GENERAL NOTES**

300 WASHERS REQUIRED BETWEEN BOLT HEAD AND BEAM GUARD RAIL AND BETWEEN NUT AND ANCHOR BRACKET. EIGHT (8) LL1 AND LL3 REQUIRED. SIXTEEN (16) LL2 REQUIRED.

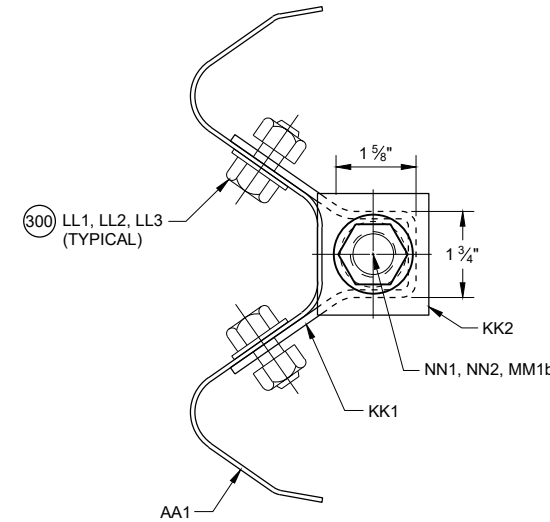
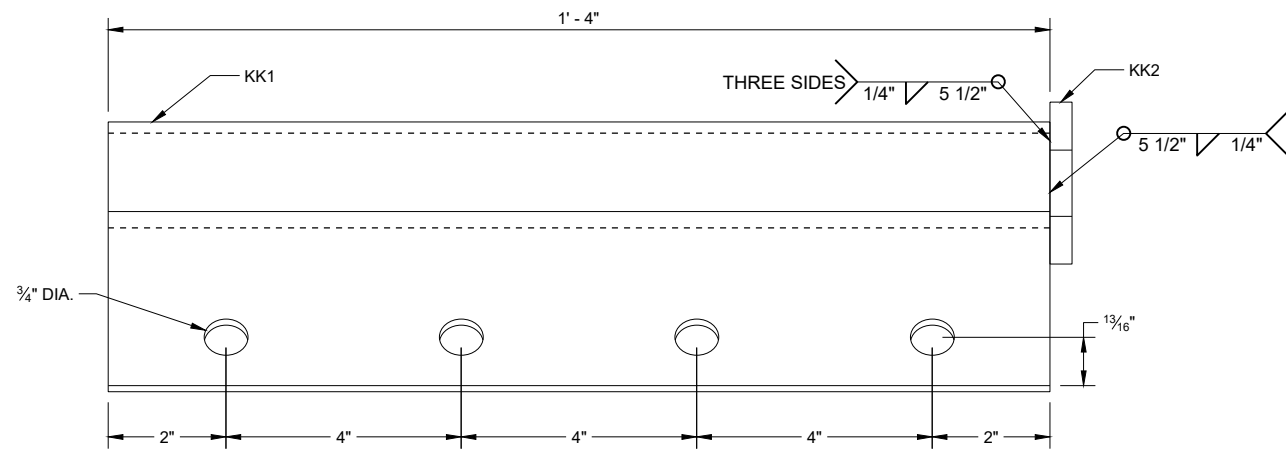

**SECTION A - A**

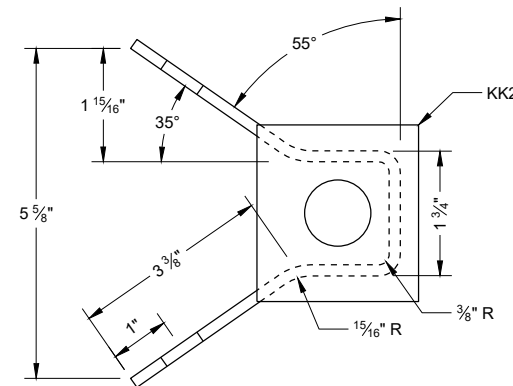
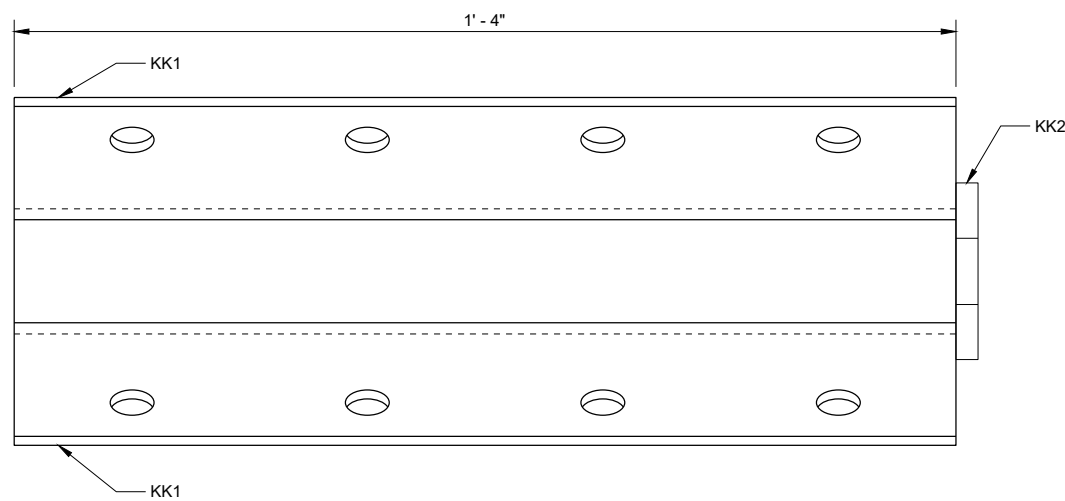

**ANCHOR BRACKET BEARING PLATE (KK2)**

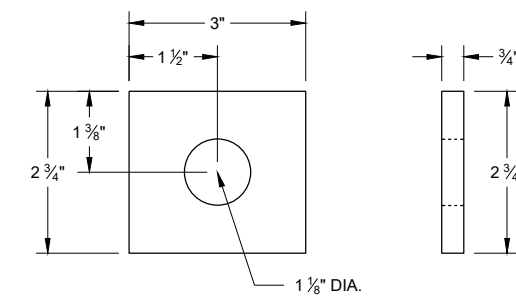

**ANCHOR BRACKET (KK1, KK2)**

**SHORT RADIUS BEAM  
GUARD (MGS) SHORT  
RADIUS TERMINAL (MGS)**

STATE OF WISCONSIN  
DEPARTMENT OF TRANSPORTATION

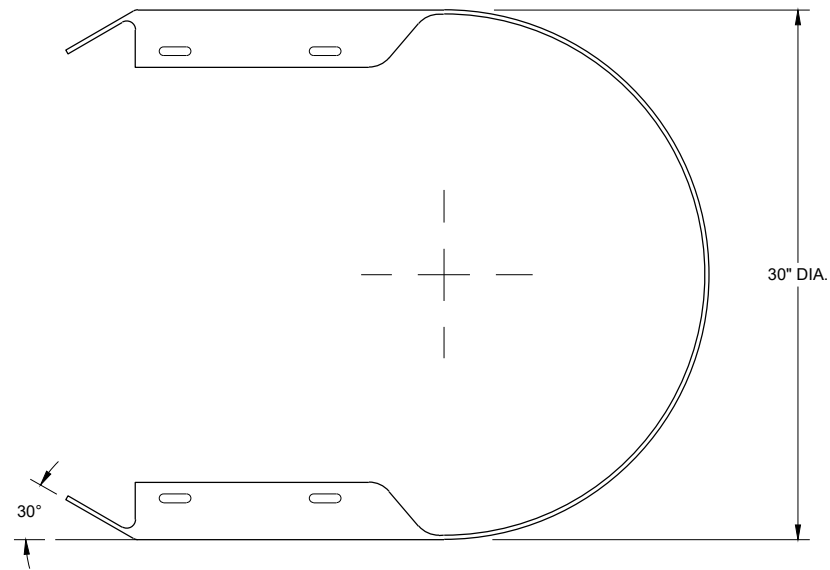

**TOP VIEW**

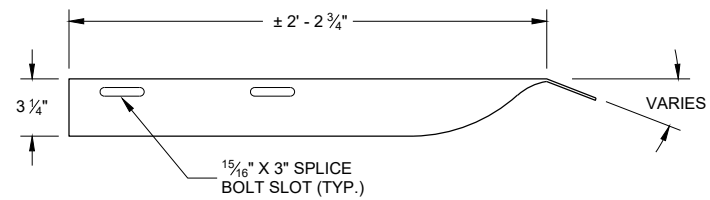

**TOP VIEW**

**GENERAL NOTES**

- (400) CROSS SECTION OF PART IS TO FIT OVER AA1 .
- (401) CROSS SECTION OF PART IS TO FIT OVER OR UNDER AA1 .

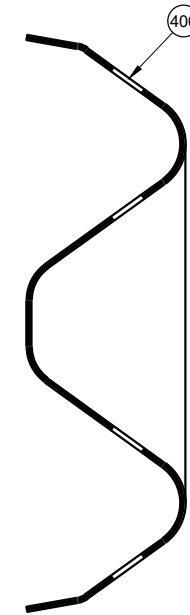

**SECTION B - B**

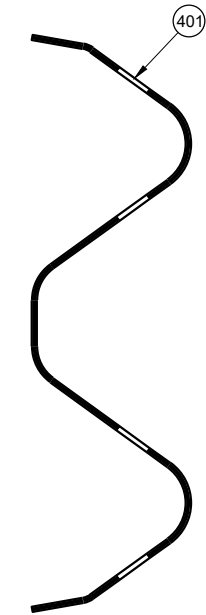

**SECTION C - C**

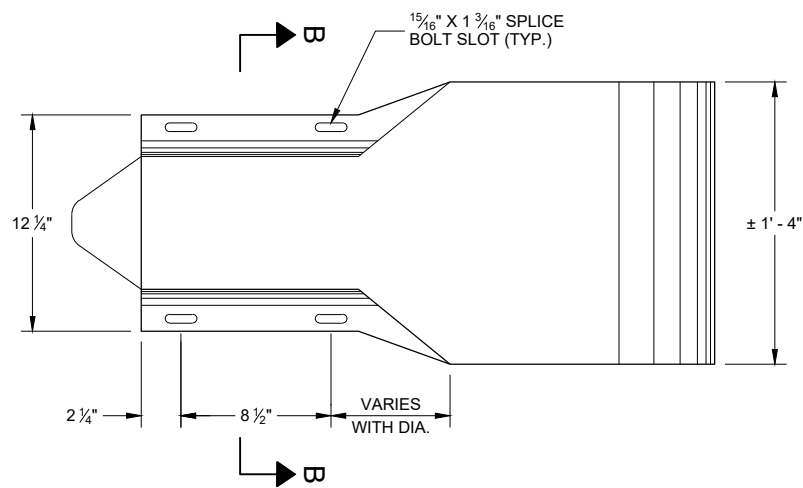

**PROFILE VIEW**

**W BEAM  
END SECTION BUFFER (AA2)**

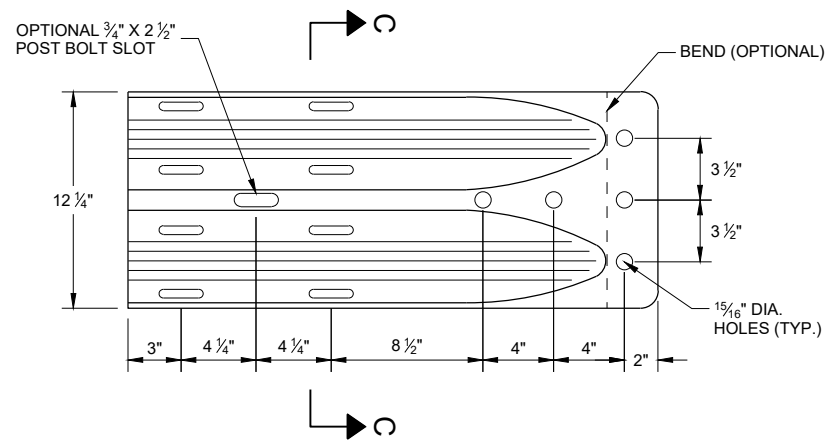

**PROFILE VIEW**

**W BEAM  
TERMINAL CONNECTOR (BB1)**

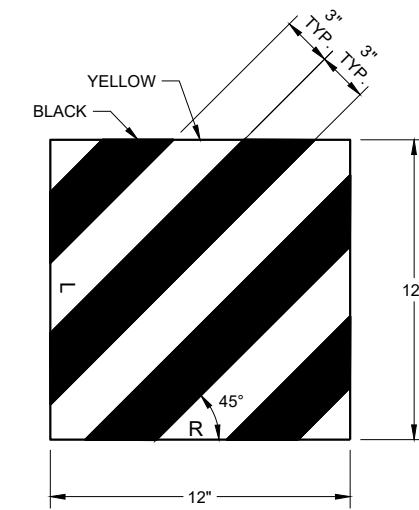

**REFLECTIVE SHEETING (UU1, UU2)**

**SHORT RADIUS BEAM  
GUARD (MGS) SHORT  
RADIUS TERMINAL (MGS)**

STATE OF WISCONSIN  
DEPARTMENT OF TRANSPORTATION



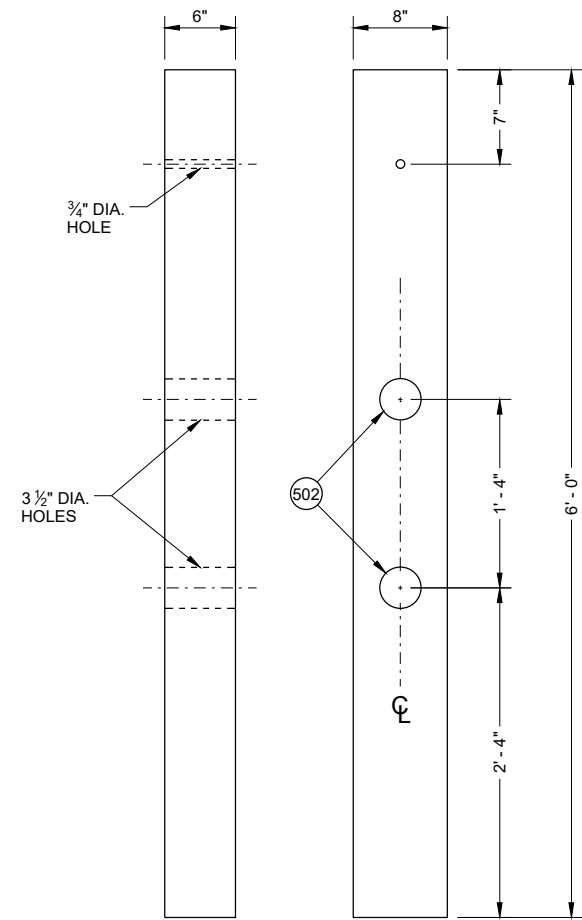

**FRONT VIEW SIDE VIEW  
CONTROLLED RELEASE  
POST (CRT) (DD2)**

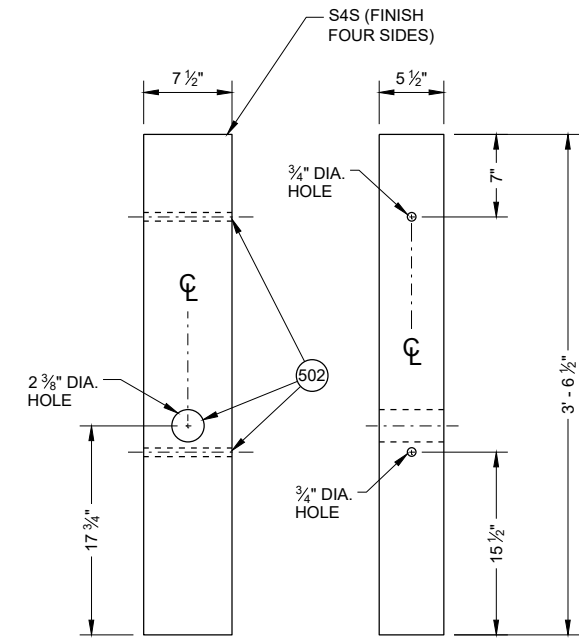

**FRONT VIEW SIDE VIEW  
WOOD BREAKAWAY POST (FF1)**

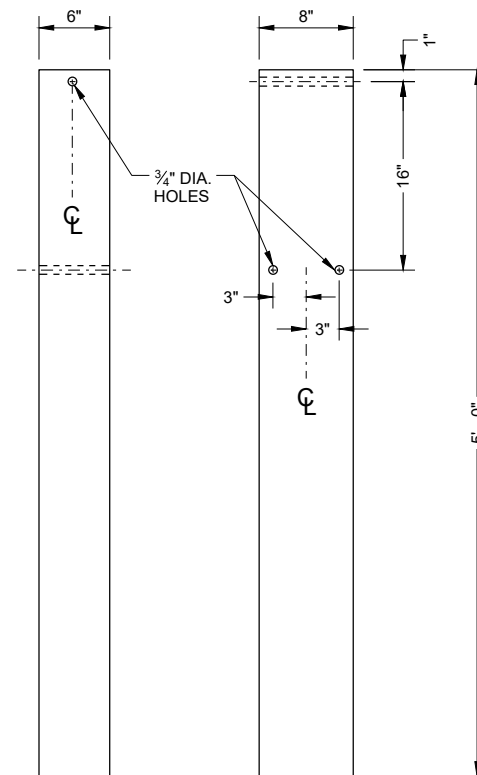

**FRONT VIEW SIDE VIEW  
FOUNDATION TUBE (QQ1)**

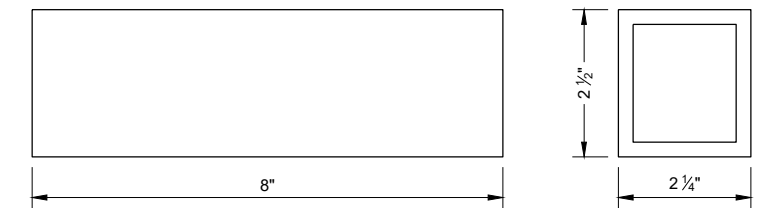

**FOUNDATION TUBE -  
ANCHOR CABLE TUBE (QQ2)**

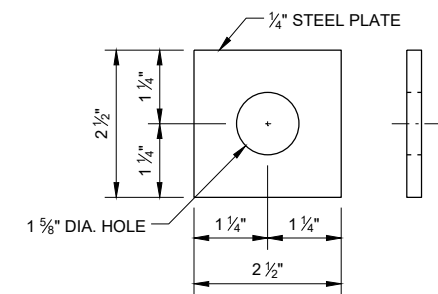

**ANCHOR CABLE TUBE  
END PLATE (QQ3)**

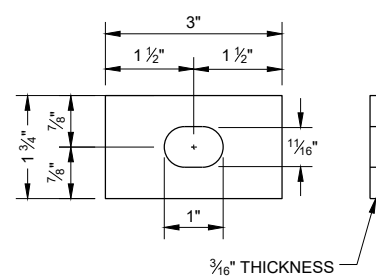

**RECTANGULAR PLATE  
WASHER (CC1)**

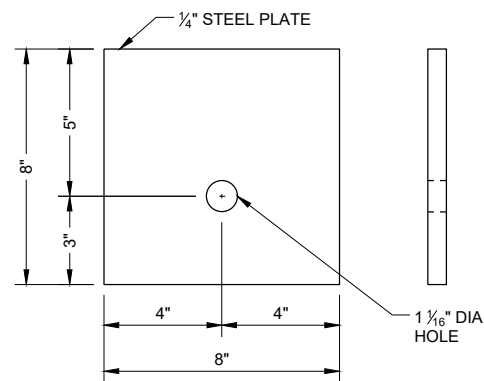

**BEARING PLATE (PP1)**

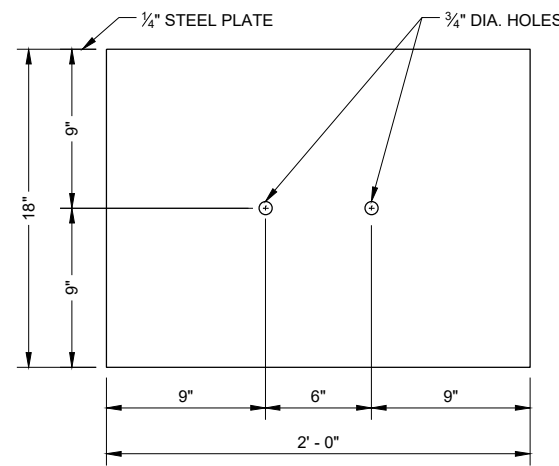

**SOIL PLATE (SS1)**

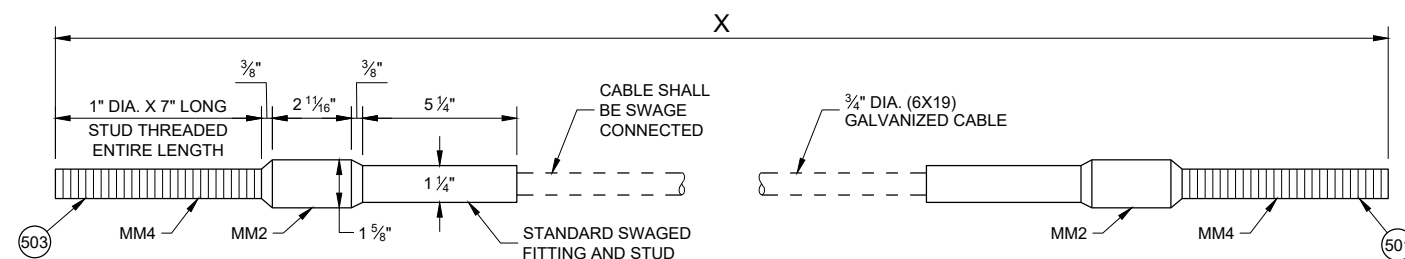

**CABLE ASSEMBLY (MM1a, MM1b)**

**"X" LENGTH**

MM1b	9' - 0"
MM1b	6' - 8"

**GENERAL NOTES**

- (500) SEE DETAIL "D" FOR LOCATION AND ATTACHMENT OF SS1.
- (501) FOR MM1a THREADED STUD ONLY REQUIRED ON ONE END. SWAGED FITTING REQUIRED.
- (502) LOCATE HOLES ON THE CENTERLINE OF THE SIDE OF THE POST.
- (503) MM1a MAY HAVE ONE THREADED STUD 4 INCHES LONG. SEE NOTE (109).

**SHORT RADIUS BEAM  
GUARD (MGS) SHORT  
RADIUS TERMINAL (MGS)**

STATE OF WISCONSIN  
DEPARTMENT OF TRANSPORTATION

**BILL OF MATERIALS - SHORT RADIUS BEAM GUARD (MGS)**

PART	DESCRIPTION	MATERIALS SPECIFICATIONS	NOTES
A1	BEAM GUARD RAIL	AASHTO M180, CLASS A, TYPE 2	
		APPROVED PRODUCER	
A2	BEAM GUARD RAIL - SHOP BENT	INDICATE ON BACK OF RAIL THE RADIUS THAT RAIL WAS BENT TO. SHOP BEND RADIUS IS TO THE NEAREST FOOT. FOLLOW AASHTO M180 ON HOW TO MARK RADIUS INFORMATION.	
		AASHTO M180, CLASS A, TYPE 2	
		APPROVED PRODUCER	
B1	BLOCK - WOOD	WISDOT SPEC. 614	SEE SDD 14B42
C1	NAIL	ASTM A153 HOT DIP CLASS D	
		ASTM F1667 TYPE 1 STYLE 12 (16 DOUBLE HEAD)	
D1	POST-STRONG POST-WOOD	WISDOT SPEC. 614	SEE SDD 14B42
D2	POST-CRT-WOOD	WISDOT SPEC. 614	
E1	POST BOLT	ASTM A307 GRADE A OR SAE J429 GRADE 2	5/8" DIA. SEE SDD 14B42 FOR BOLT GEOMETRY
		AASHTO M180	
		GALV. HOT DIP TO AASHTO M232 CLASS C / ASTM A153 CLASS C / ASTM F2329 OR GALV. MECHANICALLY TO AASHTO M298 CLASS 50, TYPE 1 / ASTM B695 CLASS 50, TYPE 1	
		UNC	
E2	POST BOLT - WASHER	ASTM F436 TYPE 1 (HARDEN TYPICALLY USED WITH STEEL) OR ASTM F844 (UNHARDENED TYPICALLY WITH WOOD)	5/8" DIA.
		GALV. AASHTO M111 / ASTM A 123 OR GALV. HOT DIP. TO AASHTO M232 CLASS C / ASTM A153 CLASS C / ASTM F2329	
E3	POST BOLT - NUT	AASHTO M180 DOUBLE RECESSED HEAVY HEX HEAD	5/8" DIA. SEE SDD 14B42 FOR BOLT GEOMETRY
		GALV. HOT DIP TO AASHTO M232 CLASS C / ASTM A153 CLASS C / ASTM F2329 OR GALV. MECHANICALLY TO AASHTO M298 CLASS 50, TYPE 1 / ASTM B695 CLASS 50, TYPE 1	
		UNC	
		OVER TAPPED NUTS OVER-SIZE AS SPECIFIED IN AASHTO 291 / ASTM A 563	
		ASTM A563 GRADE A HEAVY HEX HEAD	
F1	SPLICE BOLT	GALV. HOT DIP TO AASHTO M232 CLASS C / ASTM A153 CLASS C / ASTM F2329 OR GALV. MECHANICALLY TO AASHTO M298 CLASS 50, TYPE 1 / ASTM B695 CLASS 50, TYPE 1	5/8" DIA. SEE SDD 14B42 FOR BOLT GEOMETRY
		ASTM A307 GRADE A OR SAE J429 GRADE 2	
		UNC	
		AASHTO M180	

PART	DESCRIPTION	MATERIALS SPECIFICATIONS	NOTES
F2	SPLICE BOLT - NUT	ASTM A563 GRADE A	5/8" DIA. SEE SDD 14B42 FOR BOLT GEOMETRY
		AASHTO M180 DOUBLE RECESSED HEAVY HEX HEAD	
		GALV. HOT DIP TO AASHTO M232 CLASS C/ASTM A153 CLASS C/ASTM F2329 OR GALV. MECHANICALLY TO AASHTO M298 CLASS 50, TYPE 1/ASTM B695 CLASS 50, TYPE 1	
		OVER TAPPED NUTS OVER-SIZE AS SPECIFIED IN AASHTO 291 / ASTM A 563	
		UNC	
G1	LAG SCREW	ASTM A308 GRADE A ASTM A153 CLASS D	1/2" DIA. 6" LONG
H1	DELINEATOR - BEAM GUARD		SEE SDD 14B42 FOR MORE INFORMATION
H2	DELINEATION - SHEETING	YELLOW OR WHITE	
		WISDOT SPEC 637 TYPE SH	
		APPROVED PRODUCT LIST	
J1	FOUNDATION BACKFILL	STANDARD SPEC. 614	
AA1	BEAM GUARD RAIL - PUNCHED	AASHTO M180, CLASS A, TYPE 2	
		APPROVED PRODUCER	
AA2	BEAM GUARD RAIL - END SECTION BUFFER	AASHTO M180, CLASS A, TYPE 2	
		APPROVED PRODUCER	
BB1	BEAM GUARD RAIL - TERMINAL CONNECTOR MODIFIED	AASHTO M180, CLASS A, TYPE 2	
		APPROVED PRODUCER	
CC1	SHORT RADIUS - SQUARE WASHER	AASHTO M180	
		GALV. AASHTO M111 / ASTM A123	
EE1	NAIL	ASTM A153 HOT DIP CLASS D	
		ASTM F1667 TYPE 1 STYLE 12 (16 DOUBLE HEADED)	
FF1	POST - BCT - WOOD	S4S FINISH ON 4 SIDES	
		WISDOT SPEC. 614	
GG1	POST BOLT	ASTM A307 GRADE A OR SAE J429 GRADE 2	5/8" DIA. SEE SDD 14B42 FOR BOLT GEOMETRY
		AASHTO M180	
		GALV. HOT DIP TO AASHTO M232 CLASS C/ASTM A153 CLASS C/ASTM F2329 OR GALV. MECHANICALLY TO AASHTO M298 CLASS 50, TYPE 1/ASTM B695 CLASS 50, TYPE 1	
		UNC	
GG2	POST BOLT - WASHER	ASTM F436 TYPE 1 (HARDEN TYPICALLY USED WITH STEEL) OR ASTM F844 (UNHARDENED TYPICALLY WITH WOOD)	5/8" DIA.
		GALV. AASHTO M111 / ASTM A 123 OR GALV. HOT DIP. TO AASHTO M232 CLASS C/ASTM A153 CLASS C / ASTM F2329	

6

6

SDD 14B53 - 02g

SDD 14B53 - 02g

**SHORT RADIUS BEAM GUARD (MGS) SHORT RADIUS TERMINAL (MGS)**

STATE OF WISCONSIN  
DEPARTMENT OF TRANSPORTATION

**BILL OF MATERIALS - SHORT RADIUS BEAM GUARD (MGS)**

PART	DESCRIPTION	MATERIALS SPECIFICATIONS	NOTES
GG3	POST BOLT - NUT	ASTM A563 GRADE A	$\frac{3}{8}$ " DIA. SEE 14B42 FOR GEOMETRY
		AASHTO M180 DOUBLE RECESSED HEAVY HEX HEAD	
		GALV. HOT DIP TO AASHTO M232 CLASS C / ASTM A153 CLASS C / ASTM F2329 OR GALV. MECHANICALLY TO AASHTO M298 CLASS 50, TYPE 1 / ASTM B695 CLASS 50, TYPE 1	
		UNC	
		OVER TAPPED NUTS OVER-SIZE AS SPECIFIED IN AASHTO 291 / ASTM A 563	
ASTM A563 GRADE A HEAVY HEX HEAD			
HH1	SPLICE BOLT	GALV. HOT DIP TO AASHTO M232 CLASS C / ASTM A153 CLASS C / ASTM F2329 OR GALV. MECHANICALLY TO AASHTO M298 CLASS 50, TYPE 1 / ASTM B695 CLASS 50, TYPE 1	$\frac{3}{8}$ " DIA. SEE SDD 14B42 FOR BOLT GEOMETRY
		ASTM A307 GRADE A OR SAE J429 GRADE 2	
		UNC	
		AASHTO M180 HEAD GEOMETRY	
HH2	SPLICE BOLT - NUT	ASTM A563 GRADE A	$\frac{3}{8}$ " DIA. SEE SDD 14B42 FOR BOLT GEOMETRY
		AASHTO M180 DOUBLE RECESSED HEAVY HEX HEAD	
		GALV. HOT DIP TO AASHTO M232 CLASS C / ASTM A153 CLASS C / ASTM F2329 OR GALV. MECHANICALLY TO AASHTO M298 CLASS 50, TYPE 1 / ASTM B695 CLASS 50, TYPE 1	
		OVER TAPPED NUTS OVER-SIZE AS SPECIFIED IN AASHTO 291 / ASTM A 563	
		UNC	
JJ1	PIPE - STEEL	ASTM A53 GALVANIZED GRADE B SCHEDULE 40	10" O.D.
JJ2	TOP PLATE	ASTM A36 MIN. STRENGTH 36 KSI, OR ASTM A529 MAX. STRENGTH 50 KSI, OR ASTM A572 MAX STRENGTH 50 KSI OR ASTM A709 MAX STRENGTH 50 KSI OR ASTM A992 MAX STRENGTH 50 KSI	DIMENSIONS $\frac{3}{8}$ " X 4" X 1' - 0"
		GALV. AASHTO M111 / ASTM A123	
KK1	ANCHOR BRACKET	ASTM A36 MIN. STRENGTH 36 KSI, OR ASTM A529 MAX. STRENGTH 50 KSI, OR ASTM A572 MAX STRENGTH 50 KSI OR ASTM A709 MAX STRENGTH 50 KSI OR ASTM A992 MAX STRENGTH 50 KSI	
		GALV. AASHTO M111 / ASTM A123	
KK2	ANCHOR BRACKET - BEARING PLATE	ASTM A36 MIN. STRENGTH 36 KSI, OR ASTM A529 MAX. STRENGTH 50 KSI, OR ASTM A572 MAX STRENGTH 50 KSI OR ASTM A709 MAX STRENGTH 50 KSI OR ASTM A992 MAX STRENGTH 50 KSI	
		GALV. AASHTO M111 / ASTM A123	
LL1	ANCHOR BRACKET - BOLT	ASTM A307 GRADE B HEAVY HEX HEAD OR SAE J429 GRADE 2 HEAVY HEX HEAD	$\frac{3}{8}$ " DIA.
		GALV. HOT DIP TO AASHTO M232 CLASS C / ASTM A153 CLASS C / ASTM F2329 OR GALV. MECHANICALLY TO AASHTO M298 CLASS 50, TYPE 1 / ASTM B695 CLASS 50, TYPE 1	
		UNC	

PART	DESCRIPTION	MATERIALS SPECIFICATIONS	NOTES
LL2	ANCHOR BRACKET - WASHER	ASTM F436 TYPE 1 (HARDEN WASHER ONLY)	$\frac{3}{8}$ " DIA.
		GALV. AASHTO M111 / ASTM A123 OR GALV. HOT DIP TO AASHTO M232 CLASS C / ASTM A153 CLASS C / ASTM F2329	
LL3	ANCHOR BRACKET - NUT	ASTM A563 GRADE A	$\frac{3}{8}$ " DIA.
		GALV. HOT DIP TO AASHTO M232 CLASS C / ASTM A153 CLASS C / ASTM F2329 OR GALV. MECHANICALLY TO AASHTO M298 CLASS 50, TYPE 1 / ASTM B695 CLASS 50, TYPE 1	
		OVER TAPPED NUTS OVER-SIZE AS SPECIFIED IN AASHTO 291 / ASTM A 563	
		UNC	
MM1a	ANCHOR CABLE	AASHTO M30 / ASTM A741 INDEPENDENT WIRE CORE (IWRC) OR WIRE STRAND CORE (WCS), IMPROVED PLOW STEEL (IPS), 6X19, TYPE II OR IIc CLASS C ZINC COATED	
MM1b	ANCHOR CABLE	AASHTO M30 / ASTM A741 INDEPENDENT WIRE CORE (IWRC) OR WIRE STRAND CORE (WCS), IMPROVED PLOW STEEL (IPS), 6X19, TYPE II OR IIc CLASS C ZINC COATED	
MM2	ANCHOR CABLE - SWAGE FITTING	ASTM A576 GRADE 1035	
		SWAGE FITTINGS ARE TO BE FACTORY SWEDGED. WITH A BREAKING STRENGTH 40,000 LBS.	
		GALV. AASHTO M111 / ASTM A123	
		ASME B30.26 FORGED, CAST, OR DIE STAMPED WITH THE FOLLOWING INTO CONNECTION: NAME OF MANUFACTURER OR TRADEMARK OF CONNECTION'S MANUFACTURER, SIZE OR RATED LOAD, GRADE.	
MM3	WIRE ROPE CABLE CLAMPS	FF-C-450D TYPE 1 CLASS 1	$\frac{3}{4}$ "
		ASTM A153 HOT DIP CLASS D	
MM4	ANCHOR CABLE - SWAGE FITTING - STUD	ASTM F3125 GRADE A325 TYPE 1 OR SAE GRADE 5 OR ASTM A449 TYPE 1 HEAVY HEX HEAD	
		GALV. HOT DIP TO AASHTO M232 CLASS C / ASTM A153 CLASS C / ASTM F2329 OR GALV. MECHANICALLY TO AASHTO M298 CLASS 50, TYPE 1 / ASTM B695 CLASS 50, TYPE 1	
		UNC	
NN1	ANCHOR CABLE - NUT	ASTM A563 GRADE A	1" DIA.
		AASHTO M180 DOUBLE RECESSED HEAVY HEX HEAD	
		GALV. HOT DIP TO AASHTO M232 CLASS C / ASTM A153 CLASS C / ASTM F2329 OR GALV. MECHANICALLY TO AASHTO M298 CLASS 50, TYPE 1 / ASTM B695 CLASS 50, TYPE 1	
		OVER TAPPED NUTS OVER-SIZE AS SPECIFIED IN AASHTO 291 / ASTM A 563	
NN2	ANCHOR CABLE - NUT - WASHER	UNC	1" DIA.
		ASTM F436 TYPE 1 (HARDEN WASHER ONLY)	
		GALV. AASHTO M111 / ASTM A123 OR GALV. HOT DIP TO AASHTO M232 CLASS C / ASTM A153 CLASS C / ASTM F2329	

6

6

SDD 14B53 - 02h

SDD 14B53 - 02h

**SHORT RADIUS BEAM  
GUARD (MGS) SHORT  
RADIUS TERMINAL (MGS)**

STATE OF WISCONSIN  
DEPARTMENT OF TRANSPORTATION

**BILL OF MATERIALS - SHORT RADIUS BEAM GUARD (MGS)**

PART	DESCRIPTION	MATERIALS SPECIFICATIONS	NOTES
PP1	BEARING PLATE AT POST	ASTM A36 MIN. STRENGTH 36 KSI, OR ASTM A529 MAX. STRENGTH 50 KSI, OR ASTM A572 MAX STRENGTH 50 KSI OR ASTM A709 MAX STRENGTH 50 KSI OR ASTM A992 MAX STRENGTH 50 KSI	
		GALV. AASHTO M111 / ASTM A123	
PP2	PIPE - STEEL	ASTM A53 GALVANIZED GRADE B SCHEDULE 40	2" DIA. x 6" LONG
QQ1	FOUNDATION TUBE	ASTM A500 GRADE B	8" X 6" X 3/8"
		GALV. AASHTO M111 / ASTM A123	
QQ2	SHORT RADIUS - FOUNDATION TUBE - ANCHOR CABLE - TUBE	ASTM A500 GRADE B	DIMENSIONS 2 1/2" X 2 1/4" X 1/4" X 8"
		GALV. AASHTO M111 / ASTM A123	
QQ3	SHORT RADIUS - SOIL TUBE - ANCHOR CABLE - TUBE - END PLATE	ASTM A36 MIN. STRENGTH 36 KSI, OR ASTM A529 MAX. STRENGTH 50 KSI, OR ASTM A572 MAX STRENGTH 50 KSI OR ASTM A709 MAX STRENGTH 50 KSI OR ASTM A992 MAX STRENGTH 50 KSI	DIMENSIONS 2 1/2" X 2 1/2" X 1/4"
		GALV. AASHTO M111 / ASTM A123	
QQ4	GROUND STRUT AND YOKE - BOLT	GALV. HOT DIP TO AASHTO M232 CLASS C / ASTM A153 CLASS C / ASTM F2329 OR GALV. MECHANICALLY TO AASHTO M298 CLASS 50, TYPE 1 / ASTM B695 CLASS 50, TYPE 1	5/8 DIA.
		ASTM A307 GRADE B HEAVY HEX HEAD OR SAE J429 GRADE 2 HEAVY HEX HEAD	
		UNC	
QQ5	GROUND PLATE AND YOKE - WASHER	ASTM F436 TYPE 1 (HARDEN WASHER ONLY)	5/8 DIA.
		GALV. AASHTO M111 / ASTM A123 OR GALV. HOT DIP TO AASHTO M232 CLASS C / ASTM A153 CLASS C / ASTM F2329	
QQ6	GROUND STRUT AND YOKE - NUT	HEAVY HEX	5/8 DIA.
		UNC	
		ASTM A563 GRADE A	
		OVER TAPPED NUTS AS SPECIFIED IN AASHTO 291 / ASTM A 563	
		GALV. HOT DIP TO AASHTO M232 CLASS C / ASTM A153 CLASS C / ASTM F2329 OR GALV. MECHANICALLY TO AASHTO M298 CLASS 50, TYPE 1 / ASTM B695 CLASS 50, TYPE 1	

PART	DESCRIPTION	MATERIALS SPECIFICATIONS	NOTES
SS1	SOIL PLATE	ASTM A36 MIN. STRENGTH 36 KSI, OR ASTM A529 MAX. STRENGTH 50 KSI, OR ASTM A572 MAX STRENGTH 50 KSI OR ASTM A709 MAX STRENGTH 50 KSI OR ASTM A992 MAX STRENGTH 50 KSI	
		GALV. AASHTO M111 / A123	
TT1	SOIL PLATE - BOLT	ASTM A307 GRADE B HEAVY HEX HEAD OR SAE J429 GRADE 2 HEAVY HEX HEAD	5/8 DIA.
		GALV. HOT DIP TO AASHTO M232 CLASS C / ASTM A153 CLASS C / ASTM F2329 OR GALV. MECHANICALLY TO AASHTO M298 CLASS 50, TYPE 1 / ASTM B695 CLASS 50, TYPE 1	
		UNC	
TT2	SOIL PLATE - WASHER	ASTM F436 TYPE 1 (HARDEN WASHER ONLY)	5/8 DIA.
		GALV. AASHTO M111 / ASTM A123 OR GALV. HOT DIP TO AASHTO M232 CLASS C / ASTM A153 CLASS C / ASTM F2329	
TT3	SOIL PLATE - NUT	GALV. HOT DIP TO AASHTO M232 CLASS C / ASTM A153 CLASS C / ASTM F2329 OR GALV. MECHANICALLY TO AASHTO M298 CLASS 50, TYPE 1 / ASTM B695 CLASS 50, TYPE 1	5/8 DIA.
UU1	OBJECT MARKER - SHEETING	MUTCD / WISDOT OBJECT MARKER TYPE 3	PATTERN AND COLOR FOR SHEETING. SHEETING TYPE FOR MARKER.
		WISDOT SPEC 637 TYPE F	
		APPROVED PRODUCT LIST	
UU2	OBJECT MARKER - ALUMINUM PLATE	WISDOT SPEC 637 ALUMINUM PLATE	MATERIAL AND THICKNESS OF MATERIALS
UU3	OBJECT MARKER - SCREWS	STAINLESS SELF-TAPPING SCREWS	
VV1	FOUNDATION BACKFILL	WISDOT SPEC 614	

6

6

SDD 14B53 - 02i

SDD 14B53 - 02i

**SHORT RADIUS BEAM  
GUARD (MGS) SHORT  
RADIUS TERMINAL (MGS)**

STATE OF WISCONSIN  
DEPARTMENT OF TRANSPORTATION

APPROVED  
May 2022 /S/ Rodney Taylor  
DATE ROADWAY STANDARDS DEVELOPMENT  
ENGINEER

FHWA

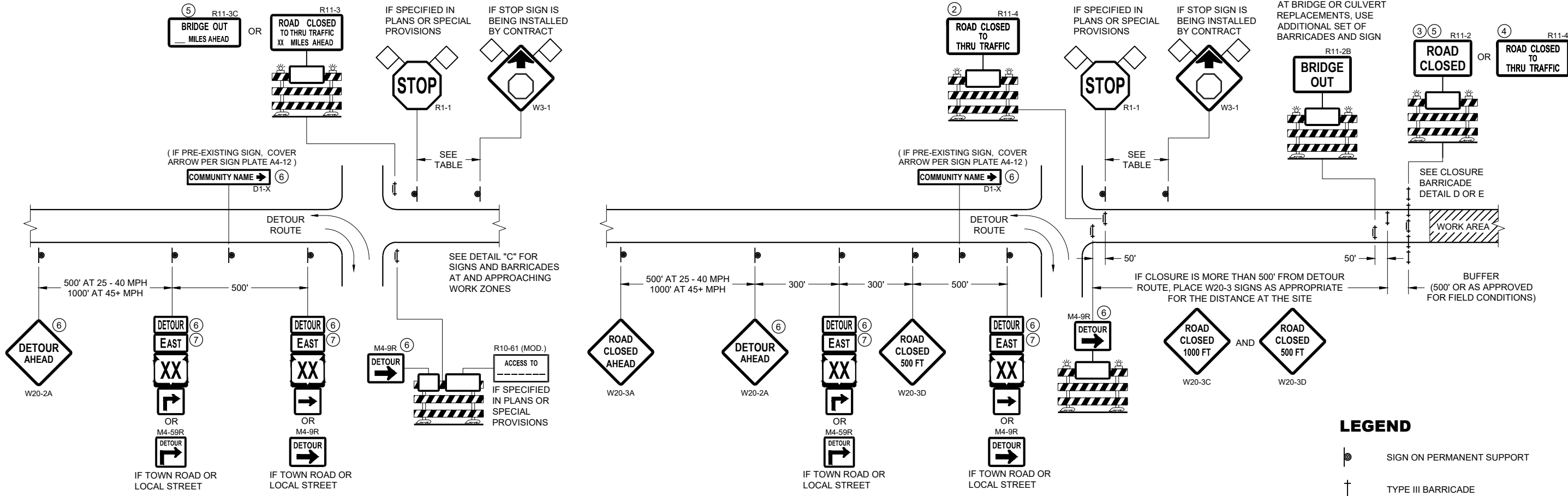

**DETAIL A  
MAINLINE CLOSURE WITH POSTED DETOUR**

WORK ZONE GREATER THAN OR EQUAL TO 1/2 MILE FROM  
DETOUR ROUTE ( 1000 FEET IF URBAN )

**DETAIL B  
MAINLINE CLOSURE WITH POSTED DETOUR**

WORK ZONE LESS THAN 1/2 MILE FROM  
DETOUR ROUTE ( 1000 FEET IF URBAN )

- LEGEND**
- SIGN ON PERMANENT SUPPORT
  - TYPE III BARRICADE
  - TYPE III BARRICADE WITH ATTACHED SIGN
  - TYPE "A" WARNING LIGHT (FLASHING)
  - WORK AREA
  - FLAGS, 16" X 16" MIN. (ORANGE)

SPEED LIMIT (MPH)	"STOP AHEAD" ADVANCE WARNING DISTANCE (FT)
25	200
30	200
35	350
40	350
45	500
50	550
55	750

- M4 - 8
- M3 - X
- M1 - 4
- M1 - 6
- M1 - 5A
- M05 - 1
- M06 - 1

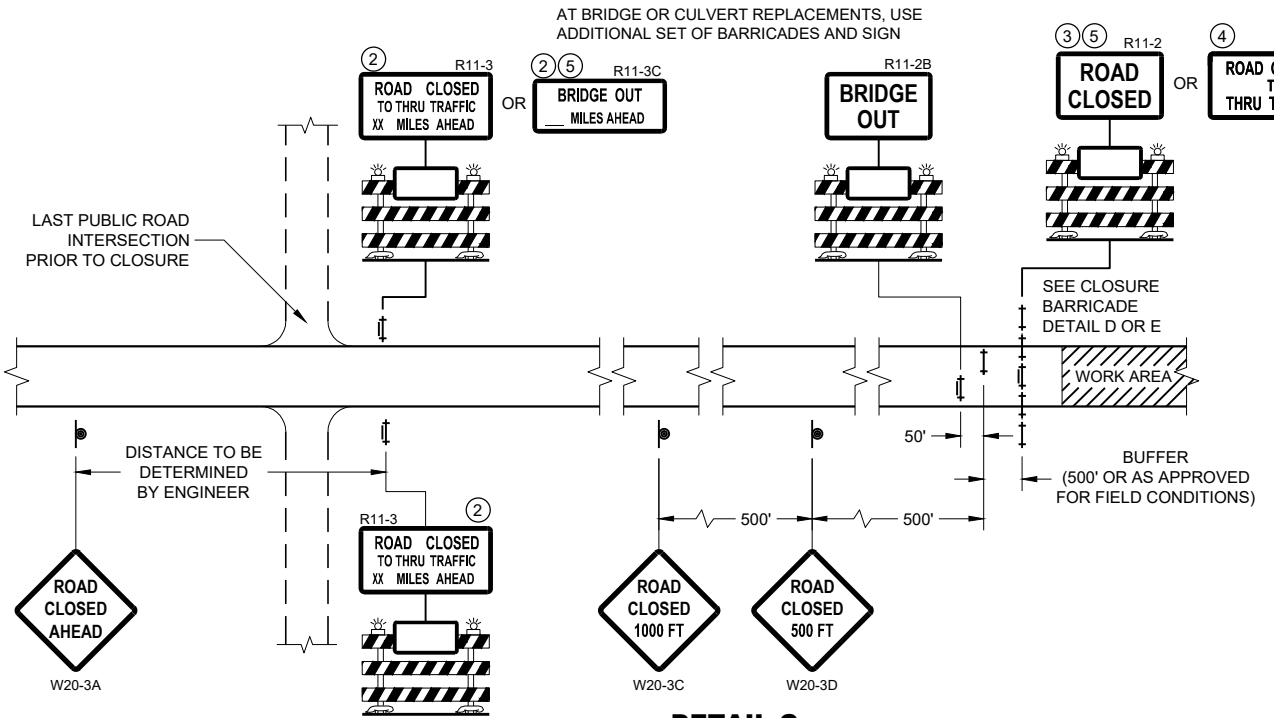

**DETAIL C  
MAINLINE CLOSURE, NO POSTED DETOUR**

SEE SDD 15C2-SHEET "b"  
FOR GENERAL NOTES  
AND FOOTNOTES ① THROUGH ⑦

**BARRICADES AND SIGNS  
FOR MAINLINE CLOSURES**

STATE OF WISCONSIN  
DEPARTMENT OF TRANSPORTATION

APPROVED  
May 2023 /S/ Andrew Heidtke  
DATE DATE WORK ZONE ENGINEER

FHWA

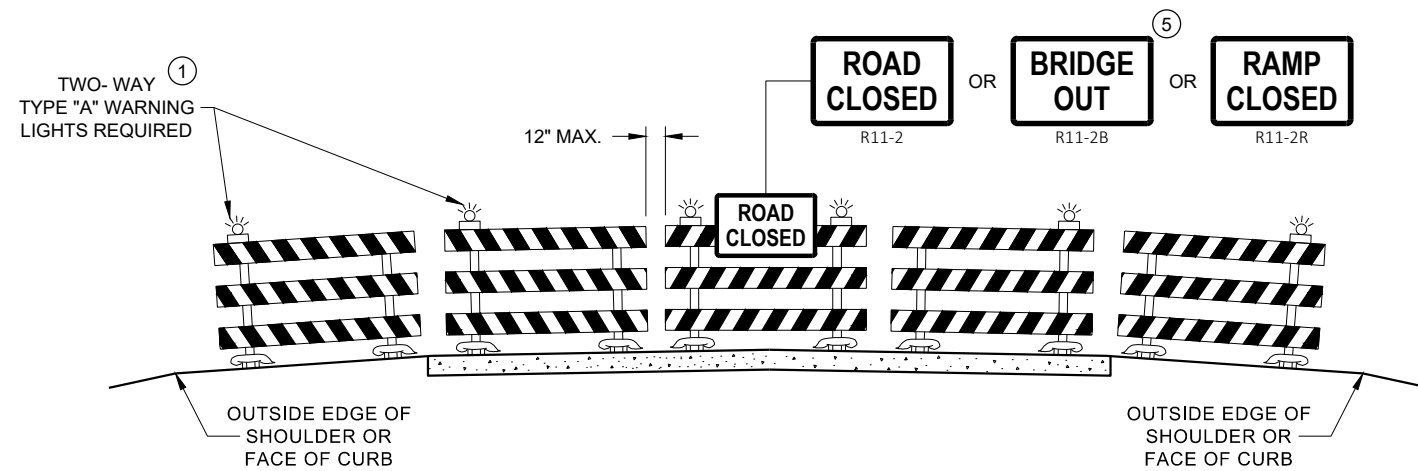

**DETAIL D  
ROAD CLOSURE BARRICADE DETAIL  
APPROACH VIEW**

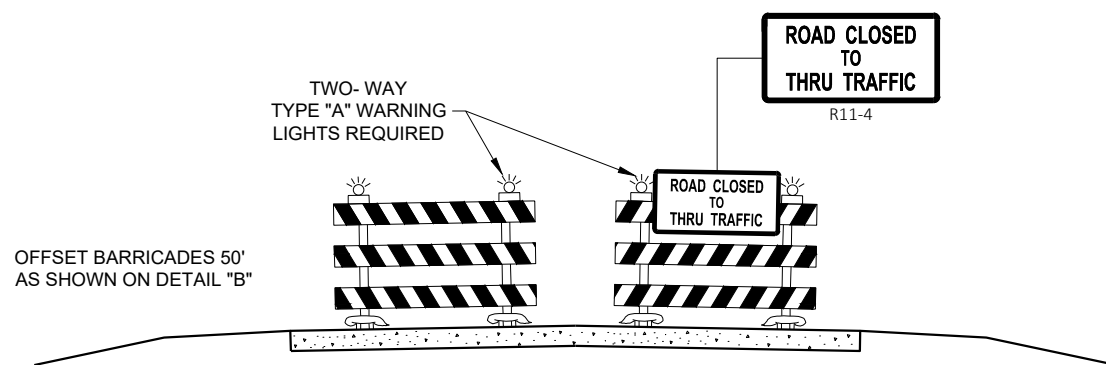

**DETAIL E  
LANE CLOSURE BARRICADE DETAIL  
APPROACH VIEW**

SEE SDD 15C2 - SHEET "a" FOR LEGEND

**GENERAL NOTES**

THE EXACT NUMBER, LOCATION, AND SPACING OF ALL SIGNS AND BARRICADES SHALL BE ADJUSTED TO FIT FIELD CONDITIONS AS APPROVED BY THE ENGINEER.

ANY SIGNS TEMPORARY OR EXISTING, WHICH CONFLICT WITH TRAFFIC CONTROL "IN USE", SHALL BE REMOVED OR COVERED AS NEEDED AND AS APPROVED BY THE ENGINEER.

THE SPACING BETWEEN TRAFFIC CONTROL SIGNS SHOULD BE ADJUSTED TO NOT CONFLICT WITH AND SHOULD PROVIDE A DESIRABLE MINIMUM OF 200 FEET CLEARANCE TO EXISTING SIGNS THAT WILL REMAIN IN PLACE.

BARRICADES THAT MUST BE MOVED FOR A WORK OPERATION SHALL BE IMMEDIATELY RE-ESTABLISHED UPON COMPLETION OF THE OPERATION, OR FOR CONTINUING OPERATIONS, AT THE END OF EACH WORKING DAY.

SIGNS THAT WILL BE IN PLACE LESS THAN 7 CONTINUOUS DAYS AND NIGHTS MAY BE MOUNTED ON PORTABLE SUPPORTS.

ALL TYPE III BARRICADES SHALL HAVE RAILS REFLECTORIZED ON BOTH FACES. STRIPES SHALL BE PROPERLY SLOPED DOWN TOWARD THE TRAFFIC SIDE OR AS SHOWN IN THE ROAD CLOSURE BARRICADE DETAIL "D" FOR FULL ROAD CLOSURES.

TYPE "A" LOW - INTENSITY FLASHING WARNING LIGHTS SHALL BE VISIBLE ON BOTH SIDES OF THE BARRICADE.

THE R11 - 2, R11 - 3, M4 - 9, R11 - 4, AND R10 - 61 SIGNS PLACED ON THE BARRICADES SHALL COVER NO MORE THAN THE TOP RAIL. THE SIGNS SHALL NOT COVER ANY PORTION OF THE MIDDLE RAIL OR BOTTOM RAILS.

"WO" AND "MO" SIGNS ARE THE SAME AS "W" AND "M" SIGNS EXCEPT THE BACKGROUND IS ORANGE.

ALL SIGNS SHALL BE 48" X 48" UNLESS OTHERWISE NOTED BELOW:

- R11 - 2 SHALL BE 48" X 30"
- R11 - 3 SHALL, R11 - 4 AND R10 - 61 SHALL BE 60" X 30"
- M4 - 9 SHALL BE 30" X 24"
- M3 - X SHALL BE 24" X 12" (36" X 18" IF NEEDED TO MATCH EXISTING SIGNS)
- M4 - 8 SHALL BE 24" X 12" (36" X 18" IF NEEDED TO MATCH EXISTING SIGNS)
- M1 - 4, M1 - 5A AND M1 - 6 SHALL BE 24" X 24" (36" X 36" IF NEEDED TO MATCH EXISTING SIGNS)
- MO5 - 1 AND MO6 - 1 SHALL BE 21" X 21" (30" X 30" IF NEEDED TO MATCH EXISTING SIGNS)
- D1 - X SHALL BE AS SHOWN ON SPECIFIC PROJECT SIGNING DETAIL SHEETS.
- R1 - 1 SHALL BE 36" X 36"

- ① TWO WARNING LIGHTS SHALL BE PROVIDED ON THE CENTER BARRICADE AND A MINIMUM OF ONE WARNING LIGHT SHALL BE PROVIDED ON EACH OF THE OTHER BARRICADES WITHIN THE ROADWAY LIMITS. SPACING OF THE WARNING LIGHTS SHALL BE UNIFORM TO THE EDGE OF ROADWAY AS SHOWN (APPROX. 8 FOOT LIGHT SPACING).
- ② THESE SIGNS AND BARRICADES ARE NOT REQUIRED IF ROAD CLOSURE BEGINS AT AN INTERSECTION.
- ③ FOR ROAD CLOSURE WITHOUT LOCAL ACCESS TO PROJECT, SEE ROAD CLOSURE BARRICADE DETAIL "D".
- ④ FOR ROAD CLOSURE WITH LOCAL ACCESS TO PROJECT, SEE ROAD CLOSURE BARRICADE DETAIL "E".
- ⑤ FOR BRIDGE OR CULVERT REPLACEMENTS, SUBSTITUTE "BRIDGE OUT" INSTEAD OF "ROAD CLOSED" ON R11 - 2 AND R11 - 3 SIGNS.
- ⑥ INSTALL DETOUR AND COMMUNITY GUIDE SIGNS AND ARROWS ONLY IF SPECIFIED IN THE CONTRACT. IF THERE ARE EXISTING ROUTE MARKER ASSEMBLIES THAT WILL REMAIN IN PLACE, ADJUST THE LOCATION OF THE DETOUR ROUTE SIGNS TO CORRESPOND WITH THE EXISTING ASSEMBLIES. MODIFY EXISTING SIGNS WHERE POSSIBLE. SEE SPECIFIC PROJECT DETOUR SIGNING DETAIL SHEETS. IF DETOUR SIGNS ARE BEING INSTALLED BY OTHERS, PLACE THE CONTRACTED TRAFFIC CONTROL SIGNS TO ALLOW FOR PLACEMENT OF ALL WARNING, DETOUR AND GUIDE SIGNS AS SHOWN.
- ⑦ "EAST" CARDINAL DIRECTION MARKERS AND RIGHT TURN ARROWS ARE SHOWN. USE OTHER CARDINAL DIRECTIONS AND ARROWS AS APPROPRIATE.

**BARRICADES AND SIGNS  
FOR  
VARIOUS CLOSURES**

STATE OF WISCONSIN  
DEPARTMENT OF TRANSPORTATION

APPROVED  
May 2023 /S/ Andrew Heidtke  
DATE WORK ZONE ENGINEER

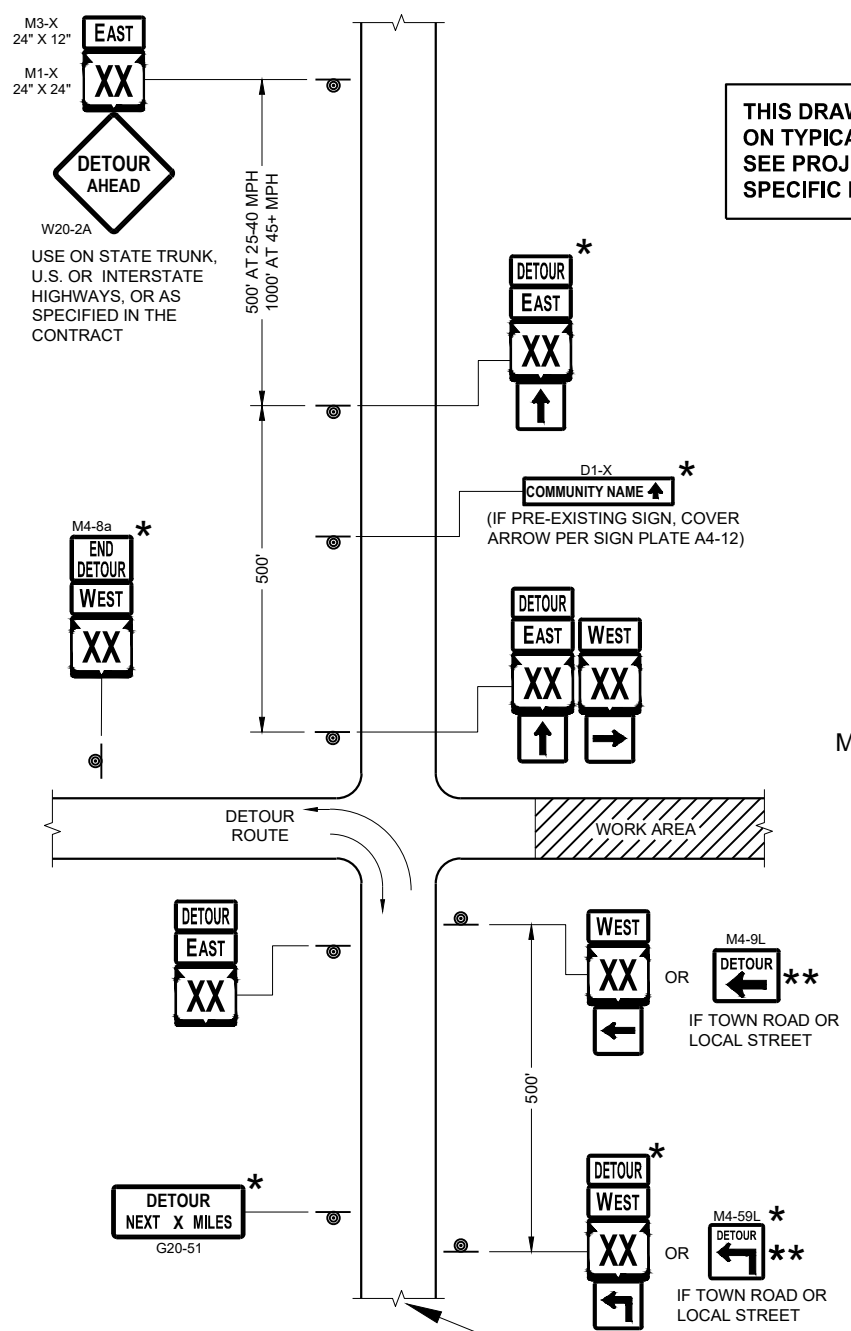

**THIS DRAWING PROVIDES GENERAL GUIDANCE ON TYPICAL DETOUR SIGN LAYOUT AND SPACING. SEE PROJECT DETOUR SIGNING SHEETS FOR SPECIFIC DETAILS FOR EACH PROJECT.**

**LEGEND**

- SIGN ON PERMANENT SUPPORT
- WORK AREA
- M4 - 8
- M3 - X
- M1 - 4
- M1 - 6
- M1 - 5A
- M05 - 1
- M06 - 1
- M06 - 1

**GENERAL NOTES**

THE EXACT NUMBER, LOCATION AND SPACING OF ALL SIGNS SHALL BE ADJUSTED TO FIT FIELD CONDITIONS AS APPROVED BY THE ENGINEER.

IF THERE ARE EXISTING ROUTE MARKER ASSEMBLIES THAT WILL REMAIN IN PLACE, ADJUST THE LOCATION OF THE DETOUR ROUTE SIGNS TO CORRESPOND WITH THE EXISTING ASSEMBLIES. SEE SPECIFIC PROJECT DETOUR SIGNING DETAIL SHEETS. MODIFY EXISTING SIGNS WHERE POSSIBLE.

THE SPACING BETWEEN TRAFFIC CONTROL AND DETOUR SIGNS SHOULD BE ADJUSTED TO NOT CONFLICT WITH AND TO PROVIDE A DESIRABLE MINIMUM OF 200 FEET CLEARANCE TO EXISTING SIGNS THAT WILL REMAIN IN PLACE.

ANY SIGNS TEMPORARY OR EXISTING, WHICH CONFLICT WITH TRAFFIC CONTROL "IN USE" SHALL BE REMOVED OR COVERED AS NEEDED AND AS APPROVED BY THE ENGINEER.

SIGNS THAT WILL BE IN PLACE LESS THAN 7 CONTINUOUS DAYS AND NIGHTS MAY BE MOUNTED ON PORTABLE SUPPORTS.

"MO" SIGNS ARE THE SAME AS "M" SIGNS EXCEPT THE BACKGROUND IS ORANGE.

SIGN SIZES SHALL BE AS FOLLOWS:

- M3-X SHALL BE 24" X 12" (36" X 18" IF NEEDED TO MATCH EXISTING SIGNS)
- M4-8 SHALL BE 24" X 12" (36" X 18" IF NEEDED TO MATCH EXISTING SIGNS)
- M1-4, M1-5A AND M1-6 SHALL BE 24" X 24" (36" X 36" IF NEEDED TO MATCH EXISTING SIGNS)
- M05-1 AND M06-1 SHALL BE 21" X 21" (30" X 30" IF NEEDED TO MATCH EXISTING SIGNS)
- M4-9 AND M4-59 SHALL BE 30" X 24"
- M4-8a SHALL BE 24" X 18"
- G20-51 SHALL BE 60" X 24"
- W20-2A SHALL BE 48" X 48"
- D1-X SHALL BE AS SHOWN ON SPECIFIC PROJECT SIGNING DETAIL SHEETS.

- \* OPTIONAL SIGNS. SEE SPECIFIC PROJECT DETOUR SIGNING DETAIL SHEETS.
- \*\* FOR A TOWN ROAD OR LOCAL STREET DETOURED ONTO A STATE TRUNK HIGHWAY, PLACE A ROAD NAME PLAQUE ABOVE THE M4-9 SIGN AS SPECIFIED IN THE CONTRACT.

MATCH POINT

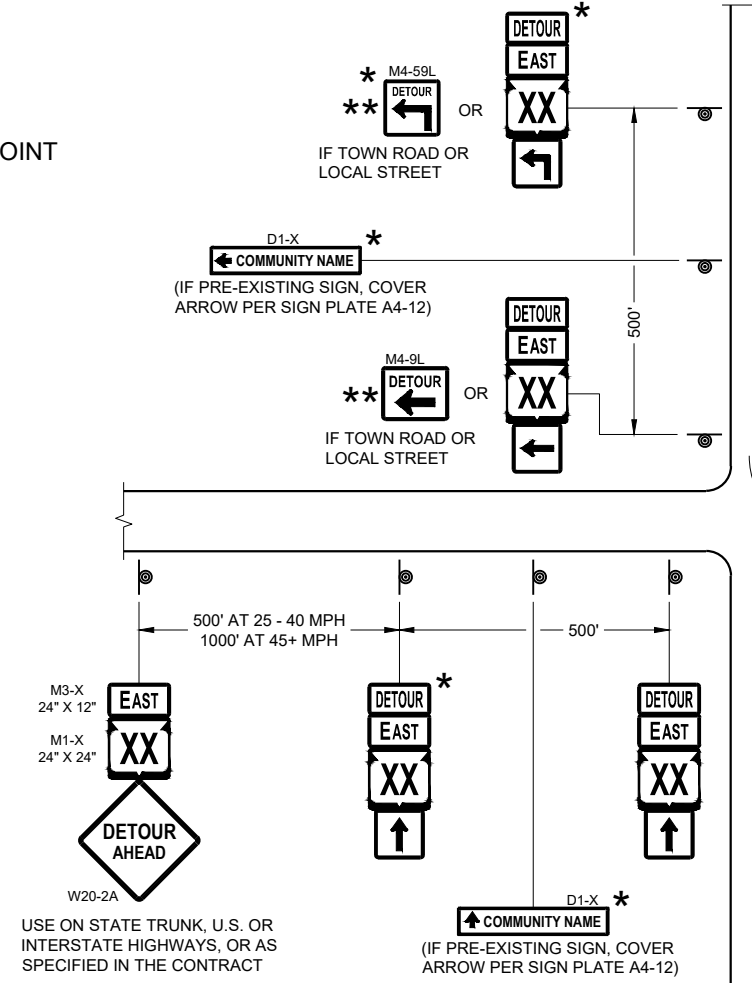

**DETAIL F  
DETOUR SIGNING**

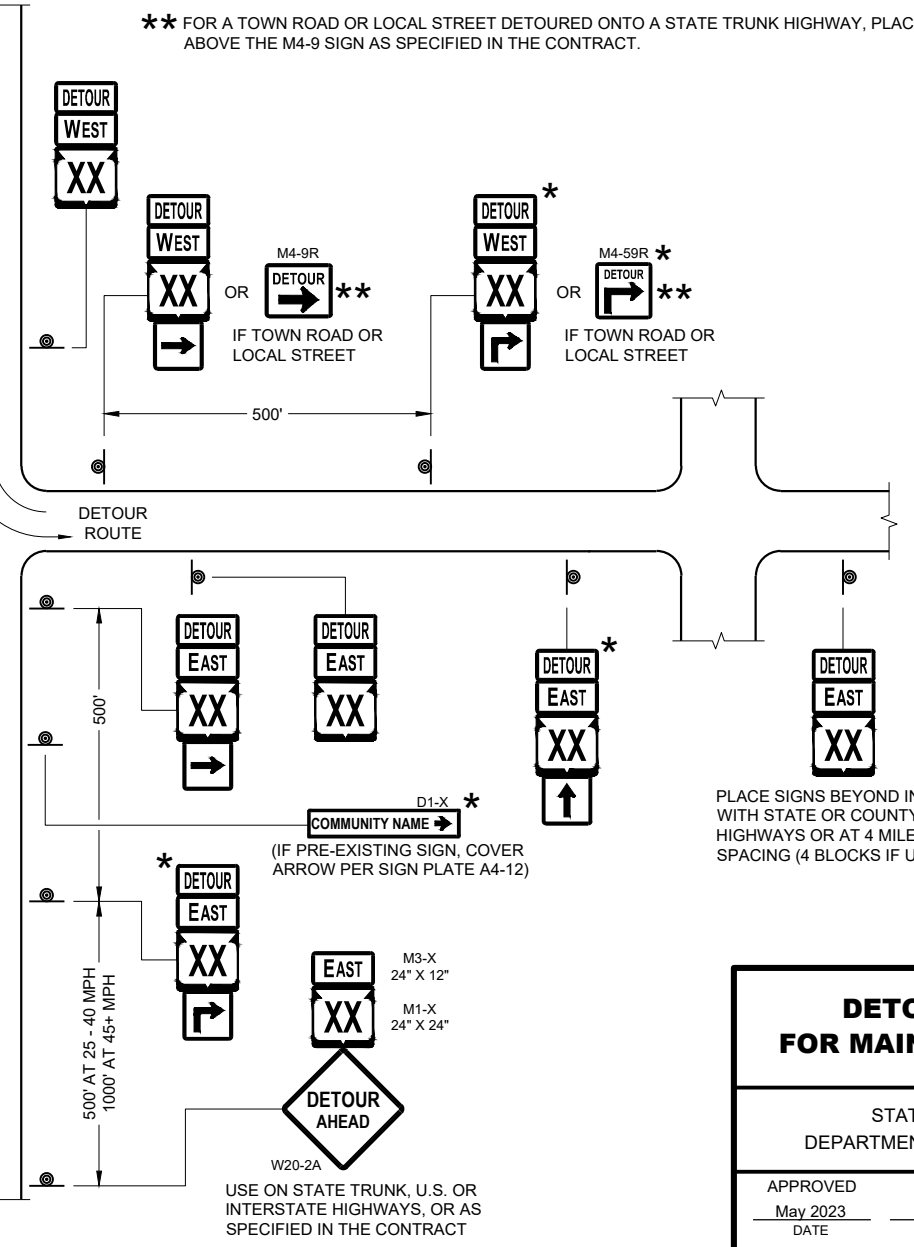

**DETOUR SIGNING  
FOR MAINLINE CLOSURES**

STATE OF WISCONSIN  
DEPARTMENT OF TRANSPORTATION

APPROVED  
May 2023 /S/ Andrew Heidtke  
DATE WORK ZONE ENGINEER

FHWA

SEE SPECIFIC PROJECT DETOUR SIGNING DETAIL SHEETS AND DETAIL A OR B ON SDD SHEET 15C02 - SHEET "a"

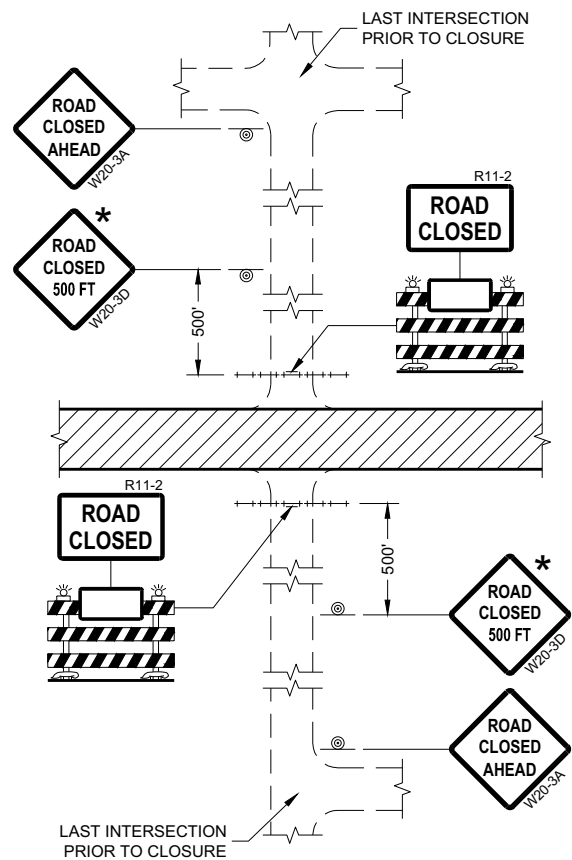

**DETAIL 1**  
(NO ACCESS TO PROJECT)

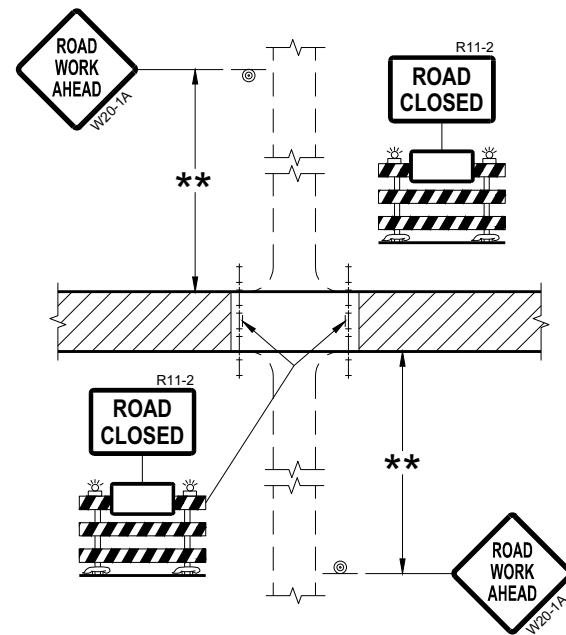

**DETAIL 2**  
(PUBLIC CROSS-TRAFFIC MAINTAINED.  
NO ACCESS TO PROJECT)

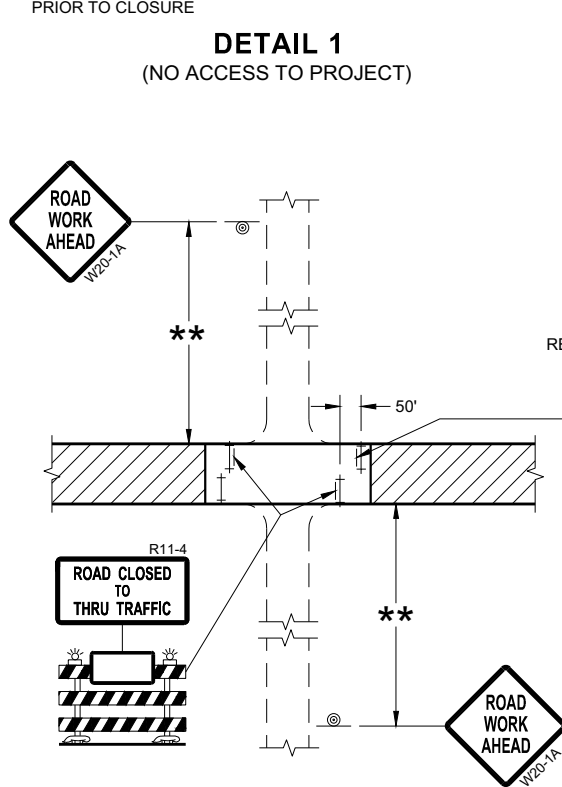

**DETAIL 3**  
(PUBLIC CROSS-TRAFFIC MAINTAINED.  
CONTRACTOR, LOCAL BUSINESS AND  
RESIDENT ACCESS TO PROJECT)

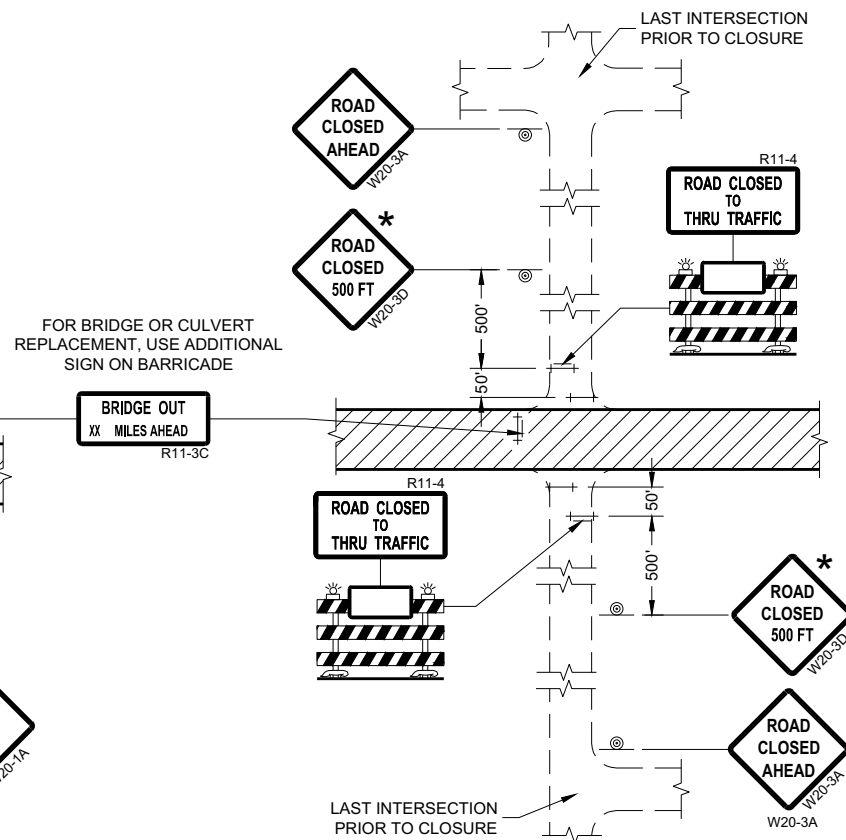

**DETAIL 4**  
(CONTRACTOR, LOCAL BUSINESS AND  
RESIDENT ACCESS TO PROJECT)

**GENERAL NOTES**

THE EXACT NUMBER, LOCATION, AND SPACING OF ALL SIGNS AND BARRICADES SHALL BE ADJUSTED TO FIT FIELD CONDITIONS AS APPROVED BY THE ENGINEER.

ANY SIGNS TEMPORARY OR EXISTING, WHICH CONFLICT WITH TRAFFIC CONTROL "IN USE" SHALL BE REMOVED OR COVERED AS NEEDED AND AS APPROVED BY THE ENGINEER.

THE SPACING BETWEEN TRAFFIC CONTROL SIGNS SHOULD BE ADJUSTED TO NOT CONFLICT WITH AND SHOULD PROVIDE A DESIRABLE MINIMUM OF 200 FEET CLEARANCE (500 FEET DESIRABLE) TO EXISTING SIGNS THAT WILL REMAIN IN PLACE.

IF A "STOP" SIGN MUST BE REMOVED FOR A WORK OPERATION, A TEMPORARY "STOP" SIGN SHALL BE PLACED PRIOR TO THE SIGN REMOVAL, OR A FLAGGER SHALL BE PROVIDED UNTIL THE SIGN IS REESTABLISHED.

BARRICADES THAT MUST BE MOVED FOR A WORK OPERATION SHALL BE IMMEDIATELY REESTABLISHED UPON COMPLETION OF THE OPERATION OR FOR CONTINUING OPERATIONS, AT THE END OF EACH WORKING DAY.

SIGNS THAT WILL BE IN PLACE LESS THAN SEVEN CONTINUOUS DAYS AND NIGHTS MAY BE MOUNTED ON PORTABLE SUPPORTS.

ALL TYPE III BARRICADES SHALL HAVE RAILS REFLECTORIZED ON BOTH FACES. STRIPES SHALL BE PROPERLY SLOPED DOWN TOWARD THE TRAFFIC SIDE OR AS SHOWN IN THE ROAD CLOSURE BARRICADE DETAIL "D" FOR FULL ROAD CLOSURES.

TYPE "A" LOW-INTENSITY FLASHING WARNING LIGHTS SHALL BE VISIBLE ON BOTH SIDES OF THE BARRICADE.

THE R11-2, R11-3, AND R11-4 SIGNS PLACED ON BARRICADES SHALL COVER NO MORE THAN THE TOP RAIL. THE SIGNS SHALL NOT COVER ANY PORTION OF THE MIDDLE OR BOTTOM RAILS.

ALL SIGNS SHALL BE 48" X 48" UNLESS OTHERWISE NOTED BELOW:  
R11-2 SHALL BE 48" X 30".  
R11-4 AND R11-3 SHALL BE 60" X 30".

- \* OMIT THE "ROAD CLOSED 500 FT." SIGN IF THE LAST INTERSECTION IS 500 FEET OR LESS FROM THE WORK ZONE.
- \*\* 500' MAX. OR AT LAST INTERSECTION, WHICHEVER IS CLOSEST.

**LEGEND**

- ⊙ SIGN ON PERMANENT SUPPORT
- ⊥ TYPE III BARRICADE
- ⊥ TYPE III BARRICADE WITH ATTACHED SIGN
- ⚡ TYPE "A" WARNING LIGHT (FLASHING)
- ▨ WORK AREA

**BARRICADES AND SIGNS  
FOR  
SIDEROAD CLOSURES**

STATE OF WISCONSIN  
DEPARTMENT OF TRANSPORTATION

APPROVED  
July 2018 /S/ Andrew Heidtke  
DATE WORK ZONE ENGINEER





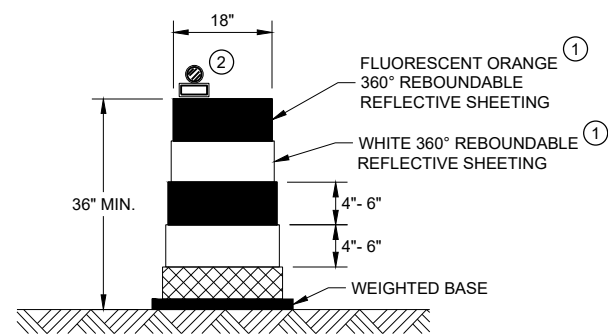

**DRUM**

BALLAST WIDTHS  
RANGE FROM 24"-36"

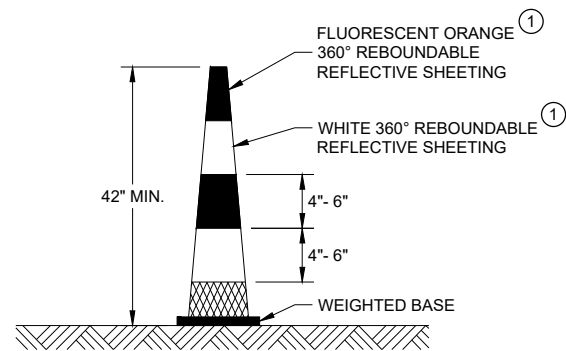

**42" CONE**

DO NOT USE IN TAPERS  
½ SPACING OF DRUMS  
BALLAST WIDTHS  
RANGE FROM 14"-20"

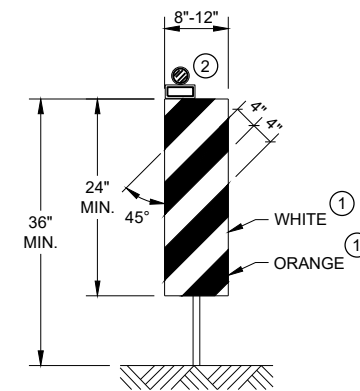

**VERTICAL PANEL**

THE STRIPES SHALL SLOPE DOWNWARD TO  
THE TRAFFIC SIDE FOR CHANNELIZATION.

**GENERAL NOTES**

- ① REFLECTIVE SHEETING SHALL FOLLOW THE REQUIREMENTS IN THE APPROVED PRODUCTS LISTING FOR SIGN SHEETING.
- ② LOCATION OF WARNING LIGHTS WHEN SHOWN ON THE PLAN.

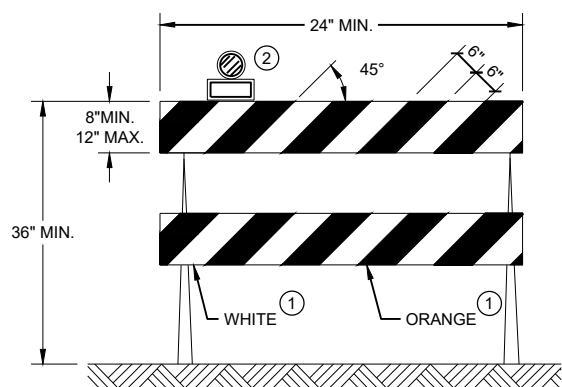

**TYPE II BARRICADE**

FOR RAILS LESS THAN 36" LONG, 4" WIDE STRIPES  
MAY BE USED. ALL STRIPES SHALL SLOPE DOWNWARD  
TO THE TRAFFIC SIDE FOR CHANNELIZATION.

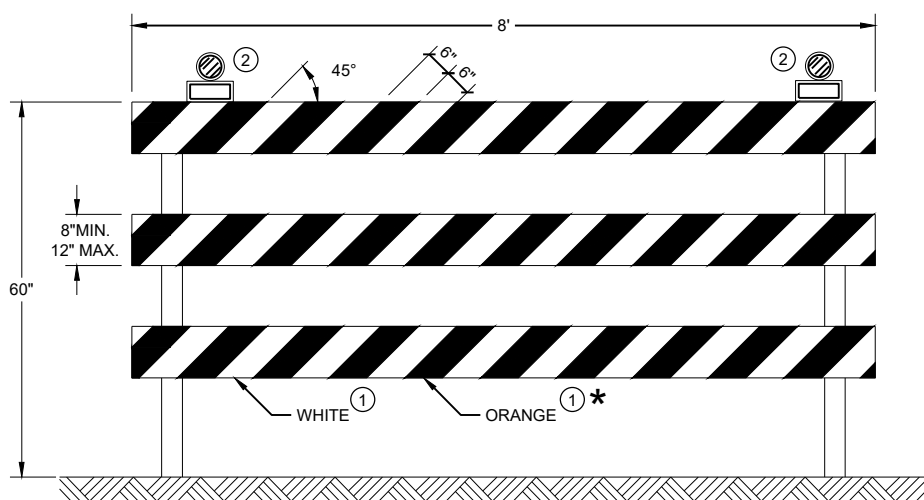

**TYPE III BARRICADE**

IF SIGN MOUNTED, DO NOT COVER MORE THAN 50% OF THE TOP  
TWO RAILS OR 33% OF THE TOTAL AREA OF THE THREE RAILS.

\* IF USED FOR A PERMANENT APPLICATION USE RED SHEETING.

<b>CHANNELIZING DEVICES DRUMS, CONES, BARRICADES AND VERTICAL PANELS</b>	
STATE OF WISCONSIN DEPARTMENT OF TRANSPORTATION	
APPROVED November 2022 DATE	/S/ Andrew Heidtke WORK ZONE ENGINEER
FHWA	

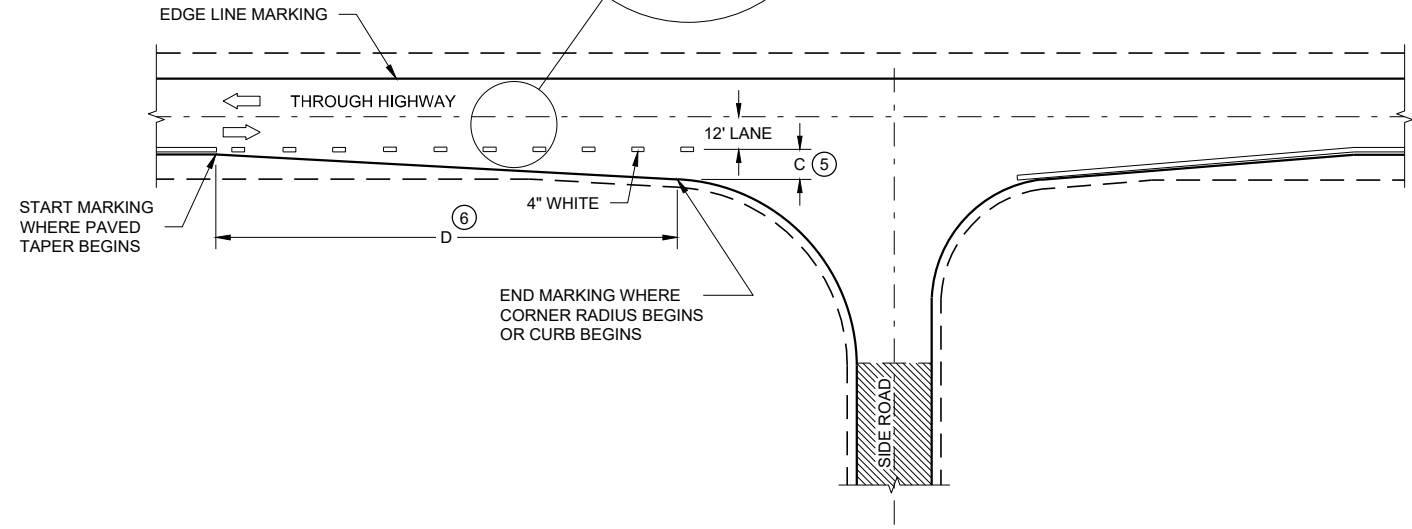
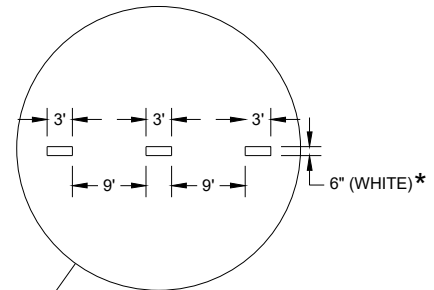

**MINOR INTERSECTION**

\* CONFIRM MARKING LINE WIDTH WITH THE MISCELLANEOUS QUANTITIES

**GENERAL NOTES**

OMIT EDGE LINES THROUGH INTERSECTIONS. CONTINUE EDGE LINES THROUGH DRIVEWAYS.

- ① WHEN DISTANCE "A" IS LESS THAN 250 FEET, OMIT LANE LINE.
- ② WHEN DISTANCE "B" IS LESS THAN 100 FEET, OMIT CHANNELIZING LANE LINE.
- ③ BARRIER LINE ENDS AT SIDE ROAD PAVEMENT / SURFACE EDGE EXTENSION.
- ④ BARRIER LINE STARTS 500 FEET PRIOR TO THE BYPASS TAPER.
- ⑤ WHEN DISTANCE "C" IS LESS THAN 4 FEET, OMIT DOTTED EXTENSION.
- ⑥ WHEN DISTANCE "D" IS LESS THAN 50 FEET, OMIT DOTTED EXTENSION.

**LEGEND**

➡ DIRECTION OF TRAVEL

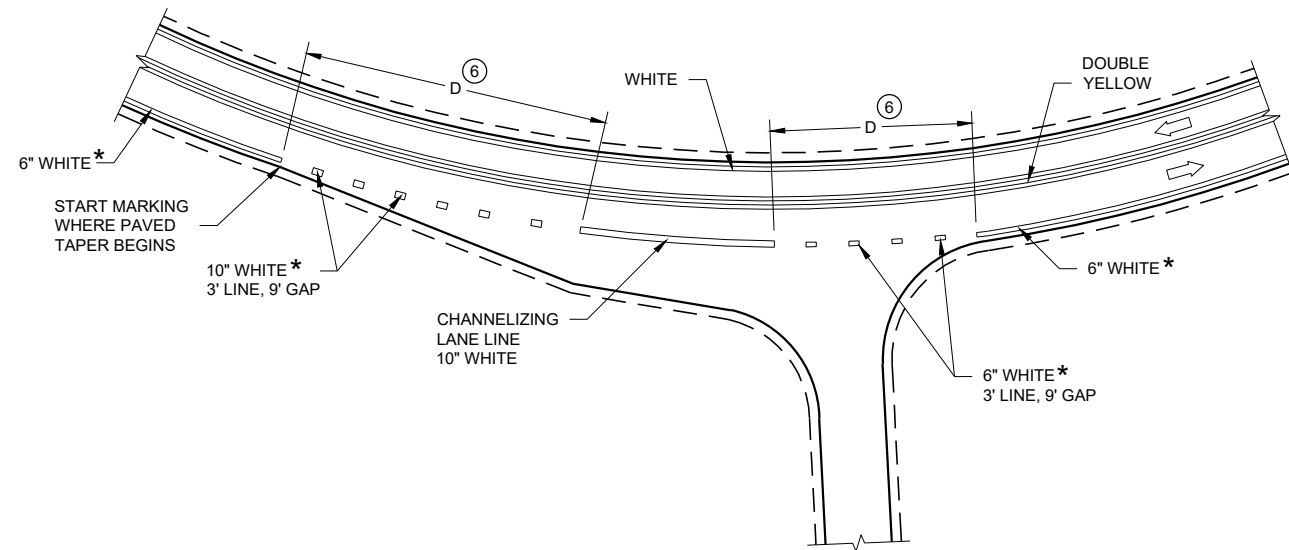

**INTERSECTION ON OUTSIDE OF CURVE**

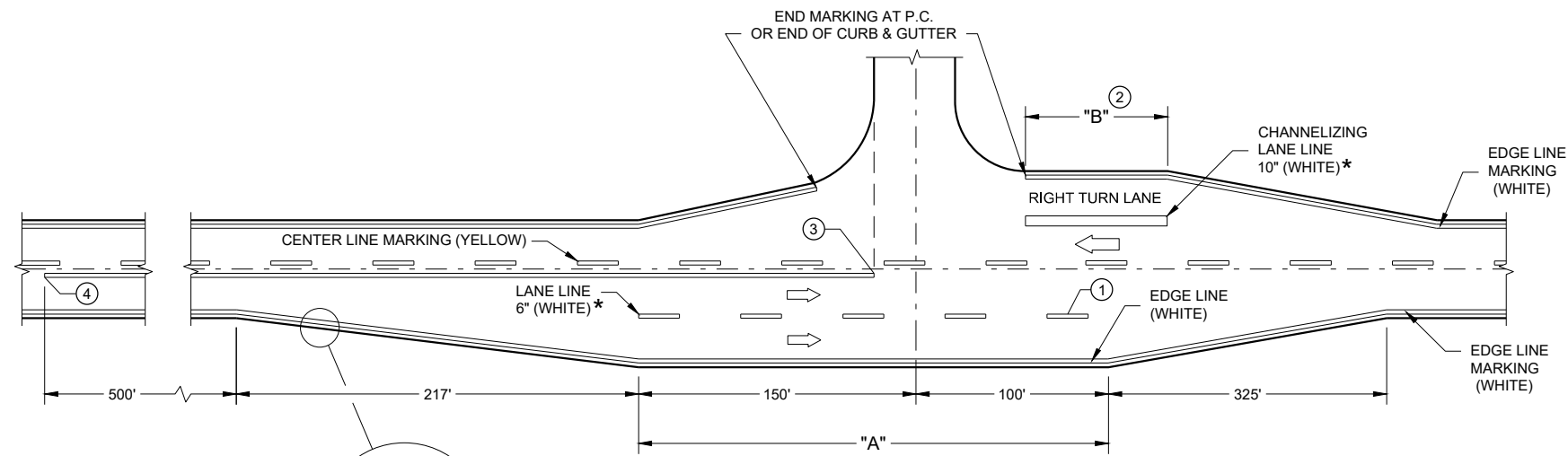

**MAJOR INTERSECTIONS  
(INTERSECTION WITH FULL RIGHT TURN LANE OR BYPASS LANE)**

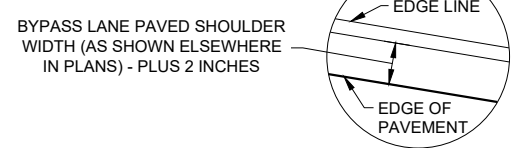





BYPASS LANE PAVED SHOULDER WIDTH (AS SHOWN ELSEWHERE IN PLANS) - PLUS 2 INCHES

**PAVEMENT MARKING  
(INTERSECTIONS)**

STATE OF WISCONSIN  
DEPARTMENT OF TRANSPORTATION

**LEGEND**

-  SIGN ON PERMANENT SUPPORT
-  TRAFFIC CONTROL DRUM
-  DIRECTION OF TRAFFIC
-  WORK ZONE

**GENERAL NOTES**

ALL SIGNS ARE 48"X48" UNLESS OTHERWISE NOTED. IF NECESSARY DUE TO SPACE CONSTRAINTS IN URBAN AREAS, 36" X 36" SIGNS MAY BE USED IF APPROVED BY THE REGIONAL TRAFFIC UNIT.

"WO" SIGN IS THE SAME AS "W" SIGN EXCEPT THE BACKGROUND IS ORANGE.

ANY SIGNS TEMPORARY OR EXISTING, WHICH CONFLICT WITH THE TRAFFIC CONTROL "IN USE" SHALL BE REMOVED OR COVERED AS NEEDED AND AS APPROVED BY THE ENGINEER.

THE EXACT NUMBER, LOCATION, AND SPACING OF ALL SIGNS AND DEVICES SHALL BE ADJUSTED TO FIT FIELD CONDITIONS AS APPROVED BY THE ENGINEER.

CHANNELIZING DEVICES PLACED ADJACENT TO WORK AREA SHALL BE PULLED BACK FROM THE TRAVEL LANE WHEN WORK IS NOT IN PROGRESS.

SIGNS THAT WILL BE IN PLACE LESS THAN 7 CONTINUOUS DAYS AND NIGHTS MAY BE MOUNTED ON PORTABLE SUPPORTS.

W20-1A AND G20-2A SIGNS ARE NOT REQUIRED IF THE WORK AREA IS WITHIN A LARGER WORK ZONE WHERE THESE SIGNS ARE ALREADY PRESENT. G20-2A SIGNS MAY ALSO BE OMITTED IF DURATION OF WORK IS LESS THAN 7 CONTINUOUS DAYS AND NIGHTS.

6

6

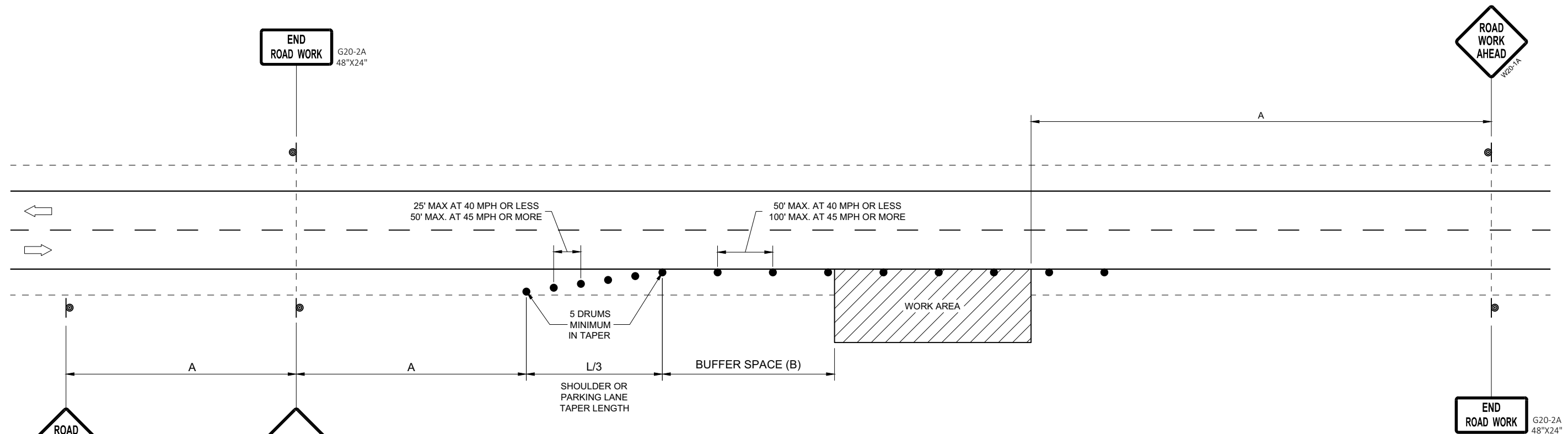

POSTED SPEED LIMIT PRIOR TO WORK STARTING (MPH)	ADVANCE WARNING SIGN SPACING (A) FEET	SHOULDER TAPER L / 3 W, LATERAL OFFSET (FT)						BUFFER SPACE (B) FEET
		3	4	5	6	7	8	
25	200'	10	14	17	21	24	28	55
30	200'	15	20	25	30	35	40	85
35	350'	20	27	34	40	47	54	120
40	350'	26	35	44	53	62	70	170
45	500'	45	59	74	89	104	119	220
50	500'	50	66	83	99	116	132	280
55	500'	54	73	91	109	127	145	335'

**TRAFFIC CONTROL, WORK ON SHOULDER OR PARKING LANE, UNDIVIDED ROADWAY**

STATE OF WISCONSIN  
DEPARTMENT OF TRANSPORTATION

APPROVED  
May 2020 /S/ Andrew Heidtke  
DATE STATEWIDE WORK ZONE TRAFFIC SAFETY ENGINEER

FHWA

SDD 15D28 - 04

SDD 15D28 - 04

**GENERAL NOTES**

DRAWING NOT TO SCALE. ALL SIGNS AND POSTS ON THIS SHEET SHALL BE PAID FOR WITH 'TRAFFIC CONTROL SIGNS' BID ITEM. ALL SIDE ROADS WHICH ARE UNDER CONSTRUCTION OF CURB AND GUTTER AND/OR GRADING SHALL BE ADEQUATELY SIGNED.

ALL SIGNS AND DEVICES SHALL BE IN CONFORMANCE WITH THE WISCONSIN MANUAL OF UNIFORM TRAFFIC CONTROL DEVICES (WMUTCD). SIGN LAYOUTS SHALL BE IN ACCORDANCE WITH THE WISDOT STANDARD SIGN PLATES.

"WO" SIGNS ARE THE SAME AS "W" SIGNS EXCEPT THAT THE BACKGROUND IS ORANGE.

ALL SIGNS ARE 48" X 48" UNLESS OTHERWISE NOTED.



THE EXACT NUMBER, LOCATION AND SPACING OF ALL SIGNS AND DEVICES SHALL BE ADJUSTED TO FIT FIELD CONDITIONS AS DIRECTED BY THE ENGINEER.

ALL SIGNS INAPPROPRIATE TO THE STATUS OF THE CONTROL ZONE, INCLUDING PRE-EXISTING SIGNS IN THE VICINITY, SHALL BE COVERED OR REMOVED AS DIRECTED BY THE ENGINEER.

SEE 15C34 FOR ADDITIONAL TRAFFIC CONTROL SIGNING WHEN CENTERLINE PAVEMENT MAKINGS ARE MISSING. 'DO NOT PASS' SIGNS MUST BE INSTALLED ON THE SAME DAY AS MILLING OPERATIONS.

- ① PLACE SIGNS 350' IN ADVANCE OF MILLED SURFACES AND AT 1 MILE INTERVALS, OR AS DIRECTED BY THE ENGINEER.
- ② PLACE SIGN 200' MIN. FROM INTERSECTION AND 200' MIN. AFTER ADVANCE WARNING SIGN SHOWN IN SDD 15C04.

**LEGEND**

-  SIGN ON TEMPORARY SUPPORT
-  DIRECTION OF TRAFFIC

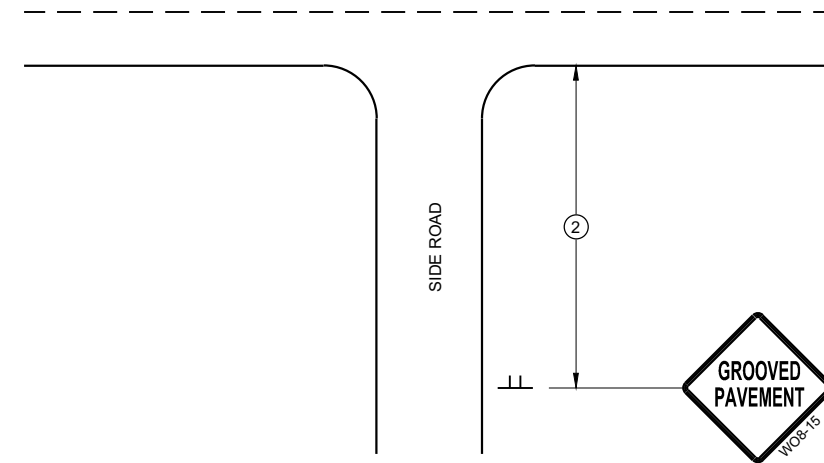

**TYPICAL SIDE ROAD APPROACH SIGN DETAIL**

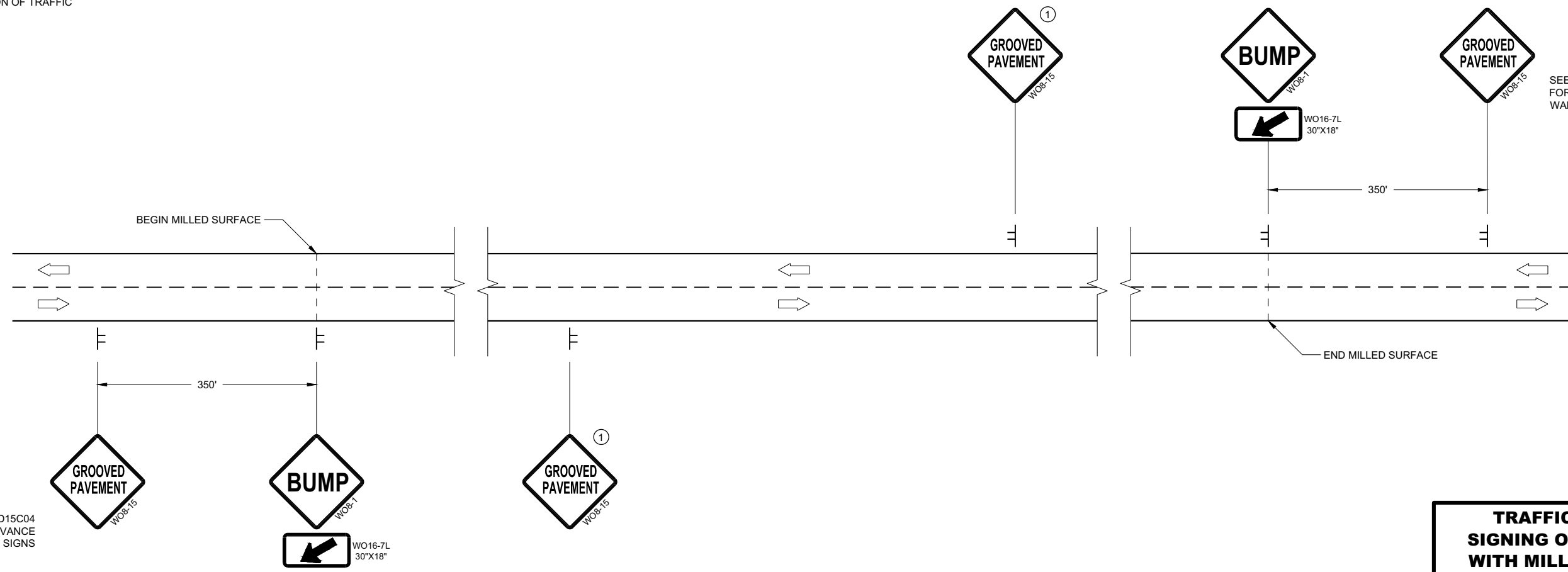

SEE SDD15C04 FOR ADVANCE WARNING SIGNS

SEE SDD15C04 FOR ADVANCE WARNING SIGNS

**DETAIL FOR SIGNING ON MILLED SURFACES**

**TRAFFIC CONTROL, SIGNING ON ROADWAYS WITH MILLED SURFACES**

STATE OF WISCONSIN  
DEPARTMENT OF TRANSPORTATION

APPROVED  
February 2020 /S/ Andrew Heidtke  
DATE WORK ZONE ENGINEER

FHWA

**GENERAL NOTES**

DRAWING NOT TO SCALE. ALL SIGNS AND POSTS ON THIS SHEET SHALL BE PAID FOR WITH 'TRAFFIC CONTROL SIGNS' BID ITEM. ALL SIDE ROADS WHICH ARE UNDER CONSTRUCTION OF CURB AND GUTTER AND/OR GRADING SHALL BE ADEQUATELY SIGNED.

ALL SIGNS AND DEVICES SHALL BE IN CONFORMANCE WITH THE WISCONSIN MANUAL OF UNIFORM TRAFFIC CONTROL DEVICES (WMUTCD). SIGN LAYOUTS SHALL BE IN ACCORDANCE WITH THE WISDOT STANDARD SIGN PLATES.

"WO" SIGNS ARE THE SAME AS "W" SIGNS EXCEPT THAT THE BACKGROUND IS ORANGE.

ALL SIGNS ARE 48" X 48" UNLESS OTHERWISE NOTED.



THE EXACT NUMBER, LOCATION AND SPACING OF ALL SIGNS AND DEVICES SHALL BE ADJUSTED TO FIT FIELD CONDITIONS AS DIRECTED BY THE ENGINEER.

ALL SIGNS INAPPROPRIATE TO THE STATUS OF THE CONTROL ZONE, INCLUDING PRE-EXISTING SIGNS IN THE VICINITY, SHALL BE COVERED OR REMOVED AS DIRECTED BY THE ENGINEER.

SEE 15C34 FOR ADDITIONAL TRAFFIC CONTROL SIGNING WHEN CENTERLINE PAVEMENT MAKINGS ARE MISSING. 'DO NOT PASS' SIGNS MUST BE INSTALLED ON THE SAME DAY AS MILLING OPERATIONS.

- ① PLACE SIGNS 350' IN ADVANCE OF CHIP SEALED OR LOOSE GRAVEL SURFACES AND AT 1 MILE INTERVALS, OR AS DIRECTED BY THE ENGINEER.
- ② PLACE SIGN 200' MIN. FROM INTERSECTION AND 200' MIN. AFTER ADVANCE WARNING SIGN SHOWN IN SDD 15C04.
- ③ ADD WO8-1 OR WO8-2 SIGN WHEN THE CONDITION IS PRESENT.

**LEGEND**

-  SIGN ON TEMPORARY SUPPORT
-  DIRECTION OF TRAFFIC

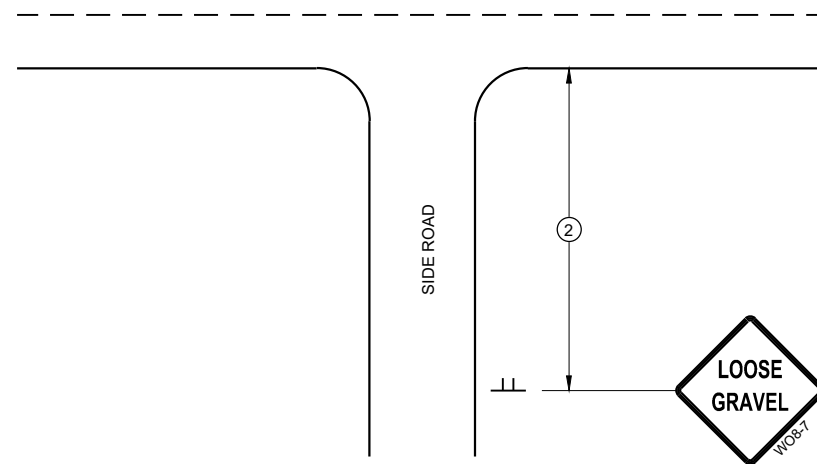

**TYPICAL SIDE ROAD APPROACH SIGN DETAIL**

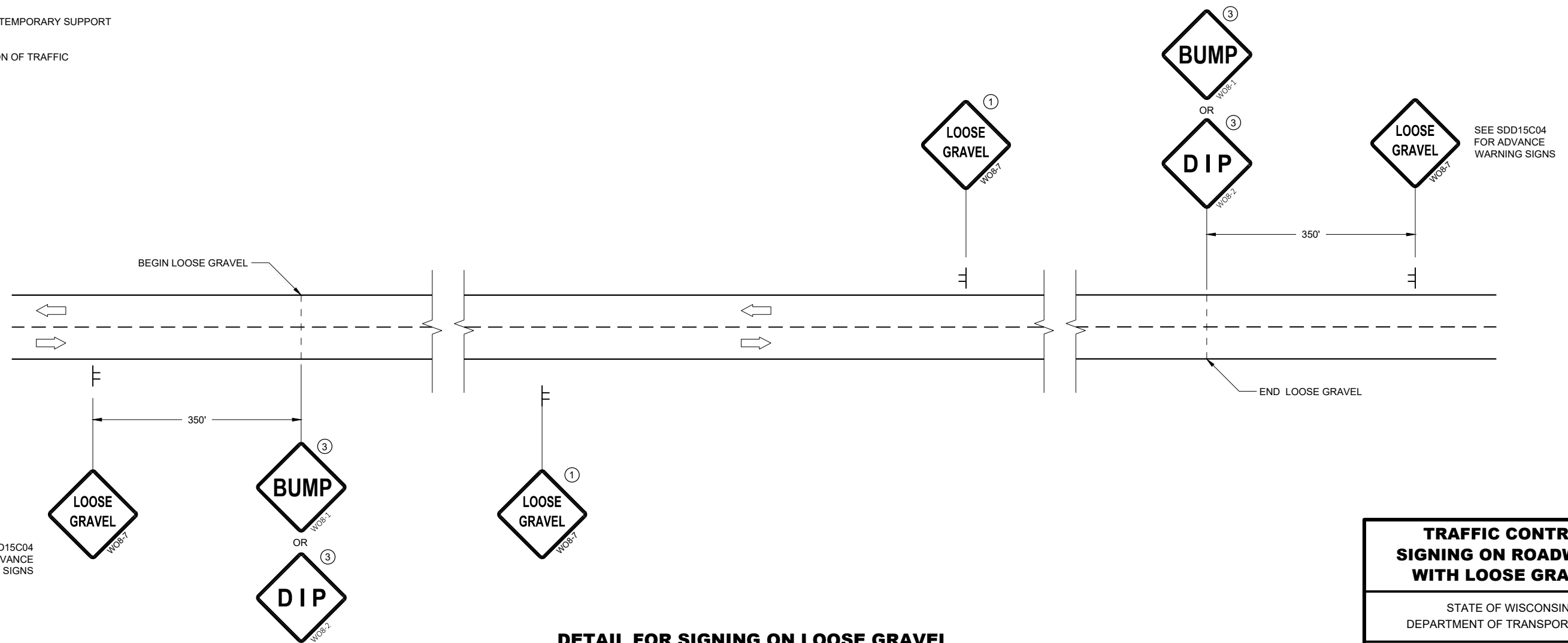

**DETAIL FOR SIGNING ON LOOSE GRAVEL OR CHIP SEALED SURFACES**

SEE SDD15C04 FOR ADVANCE WARNING SIGNS

SEE SDD15C04 FOR ADVANCE WARNING SIGNS

**TRAFFIC CONTROL SIGNING ON ROADWAYS WITH LOOSE GRAVEL**

STATE OF WISCONSIN  
DEPARTMENT OF TRANSPORTATION

APPROVED  
February 2021 /S/ Andrew Heidtke  
DATE WORK ZONE ENGINEER

FHWA

URBAN AREA

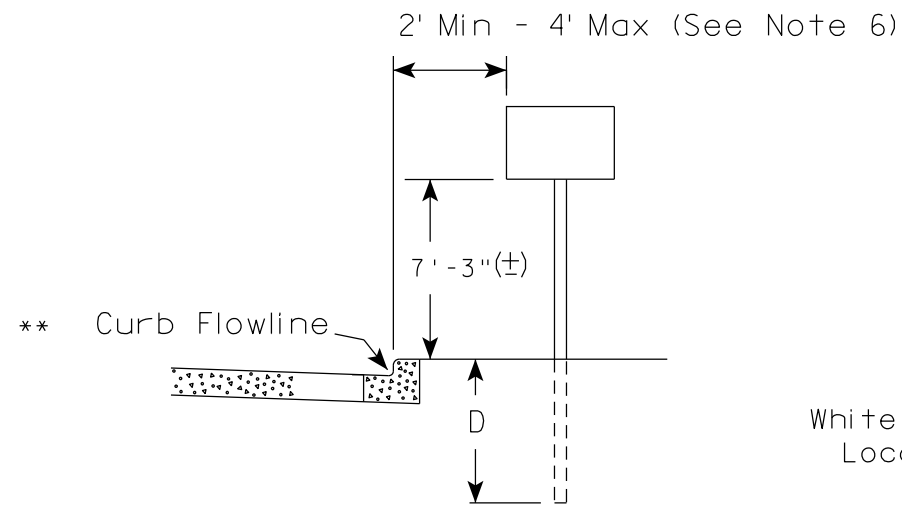

RURAL AREA (See Note 2)

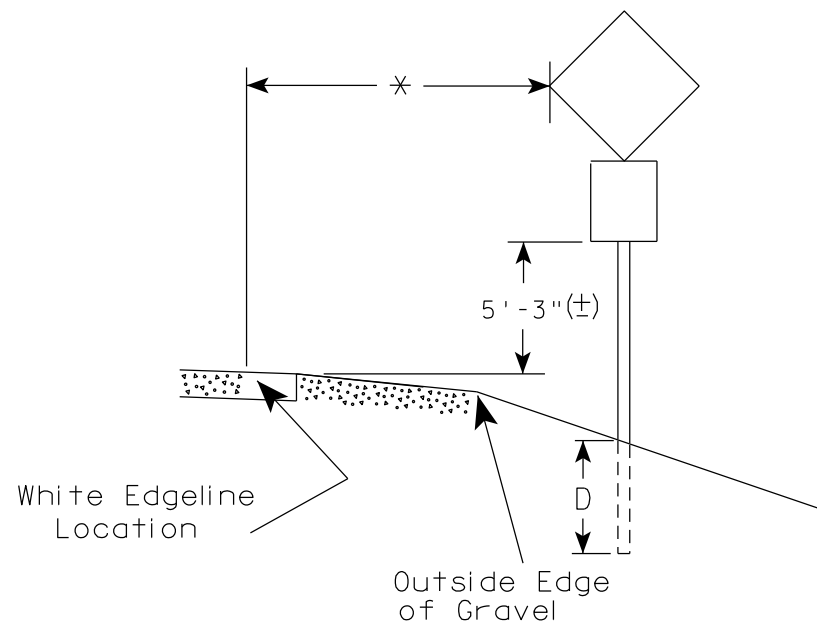
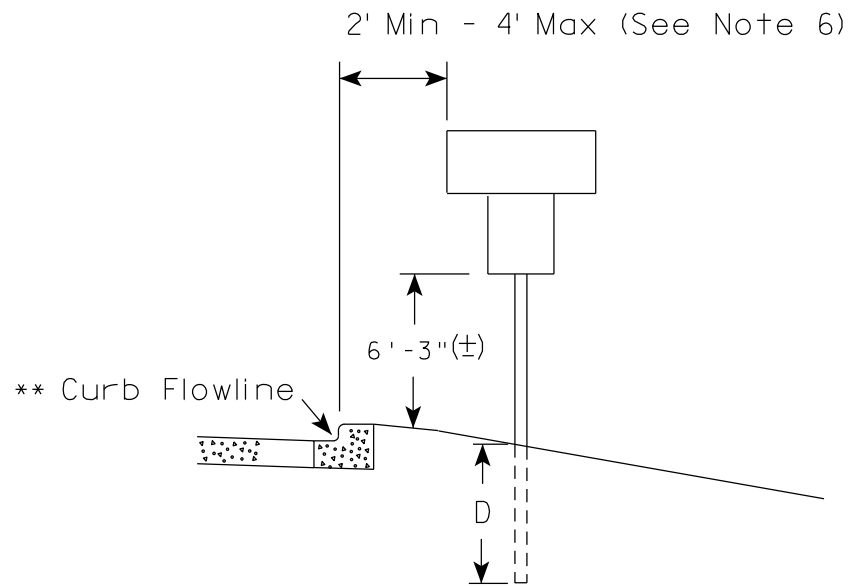
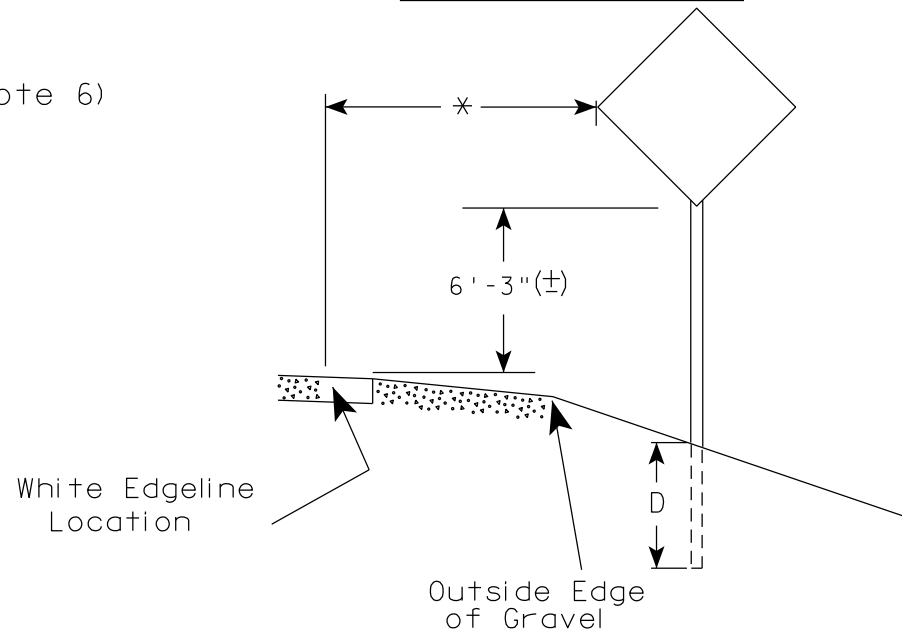

POST EMBEDMENT DEPTH

Area of Sign Installation ( Sq. Ft. )	D ( Min )
20 or Less	4'
Greater than 20	5'

GENERAL NOTES

1. Signs wider than 4 feet or 20 sq.ft or larger, shall be mounted on multiple posts. Refer to plate A4-4.
2. If signs are mounted on or behind barrier wall, see A4-10 sign plate.  
The Double Arrow sign (W12-1D) shall be mounted at a height of 2'-3" (±). The Chevron sign (W1-8), Roundabout Chevron panel (R6-4B), Enhanced Reference Markers, Clearance Markers (W5-52), Mile Markers (D10 series), In Road Object Markers (W5-54) & End of Road Markers (W5-56) shall be mounted at a height of 4'-3" (±).
3. For expressways and freeways, mounting height is 7'- 3" (±) or 6'-3" (±) depending upon existence of a sub-sign.
4. Minimum mounting height for signs mounted on traffic signal poles is 5'- 3" (±).
5. Offset distance shall be consistent with existing signs or consistent throughout length of project.
6. The (±) tolerance for mounting height is 3 inches.
7. Folding signs shall be mounted at a height of 5'-3" (±) or as directed by the Engineer.

\* \* The existence of curb and gutter does not in itself mandate the vertical clearance illustrated. That height is typically measured where there is sidewalk adjacent to the roadway or parking is permitted. In the absence of sidewalk vertical clearance is measured from the top of the curb. Offset of signs is measured from the flow line.

\* 6 feet from edge of a paved shoulder or 12 feet from the edge of pavement (edge line location) or 2 feet from outside edge of gravel, whichever is greater unless directed by project engineer.

TYPICAL INSTALLATION OF PERMANENT TYPE II SIGNS ON SINGLE POSTS

WISCONSIN DEPT OF TRANSPORTATION

APPROVED *Matthew R. Rauch*  
for State Traffic Engineer

DATE 5/13/2020 PLATE NO. A4-3.22

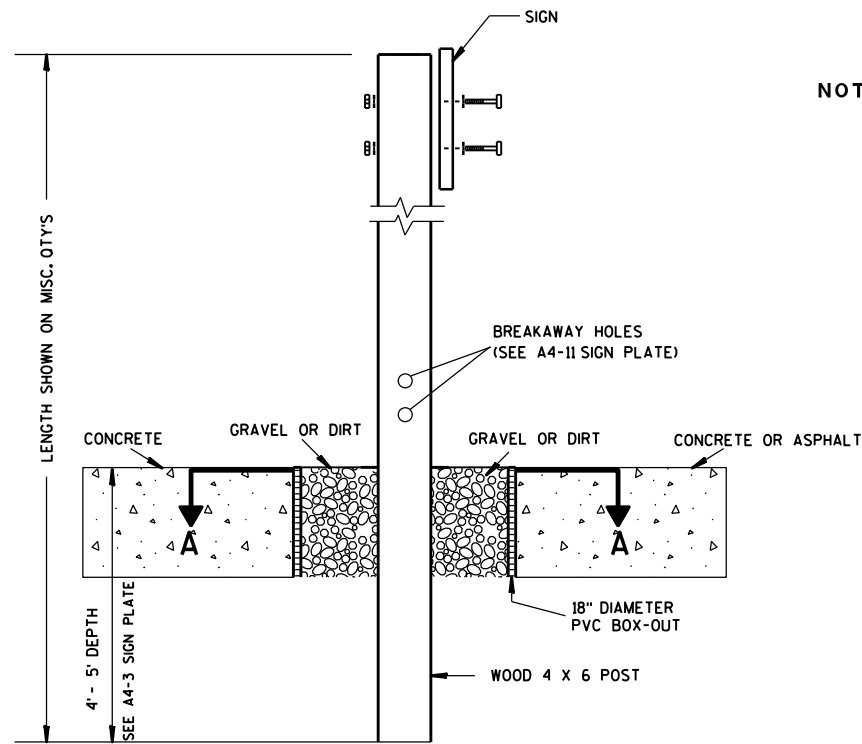

**ELEVATION VIEW**

**DETAIL OF WOOD 4 X 6 SIGN POST IN BOX-OUT**

- NOTES:**
1. ALL MATERIAL TO BE APPROVED BY ENGINEER PRIOR TO INSTALLATION
  2. SEE SIGN PLATE A4-8 FOR SIGN HARDWARE REQUIREMENTS
  3. 18 INCH X 18 INCH SQUARE BOX-OUTS MAY BE USED FOR INSTALLATIONS IN EXISTING CONCRETE OR ASPHALT LOCATIONS.

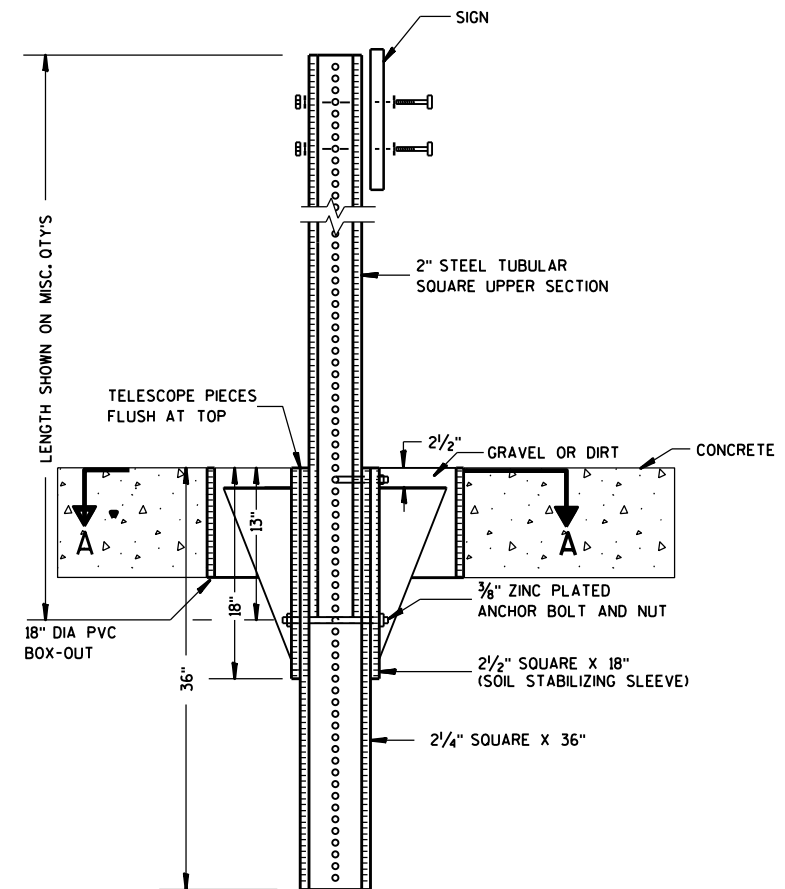

**ELEVATION VIEW**

**DETAIL OF STEEL 2 X 2 SIGN POST IN BOX-OUT**

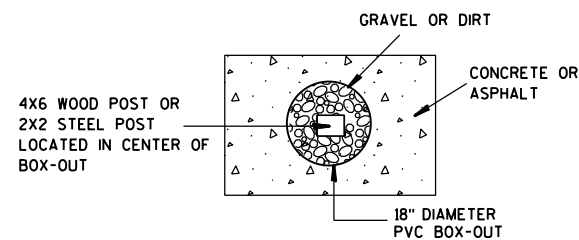

**PLAN VIEW**

**FOR NEW CONCRETE/ ASPHALT INSTALLATIONS**

<b>SIGN POST BOX-OUTS A4-3B</b>	
<small>WISCONSIN DEPT OF TRANSPORTATION</small>	
APPROVED <i>Matthew R. Rauch</i> <small>for State Traffic Engineer</small>	
<small>DATE 1/27/14</small>	<small>PLATE NO. A4-3B.1</small>



GENERAL NOTES

1. For 3 or 4 post installations, individual post spacing shall be greater than 3'-6".
2. See tables below for required number of posts.
3. For expressways and freeways, mounting height is 7'-3" (±) or 6'-3" (±) depending upon existence of sub-sign.
4. The (±) tolerance for mounting height is 3 inches.
5. J-Assemblies are considered to be one sign for mounting height.
6. Offset distance shall be consistent with existing signs or consistent throughout length of project.
7. Folding signs shall be mounted at a height of 5'-3" (±) or as directed by the engineer.
8. The Double Arrow sign (W12-1) shall be mounted at a height of 2'-3" (±). The Chevron sign (W1-8), Roundabout Chevron panel (R6-4B), Clearance Markers (W5-52), Mile Markers (D10 series), In Road Object Markers (W5-54) & End of Road Markers (W5-56) shall be mounted at a height of 4'-3" (±).

URBAN AREA

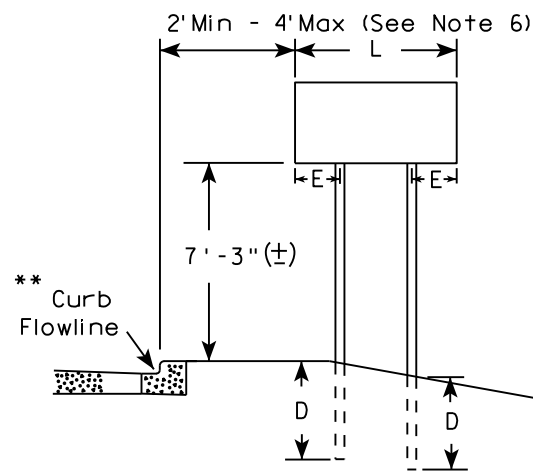

RURAL AREA (See Note 3)

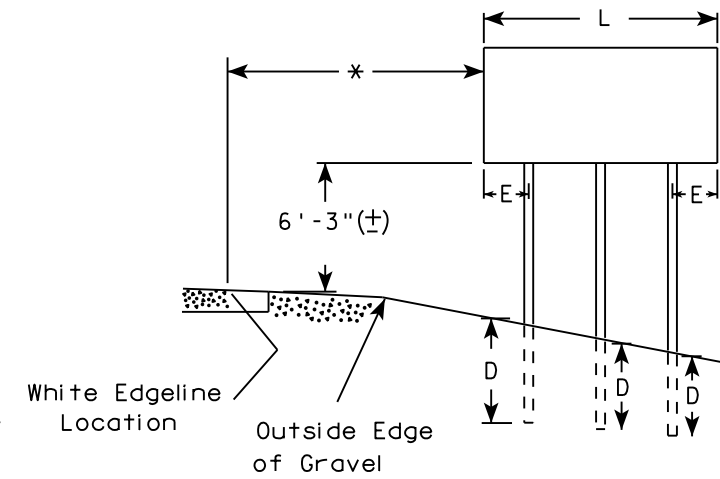
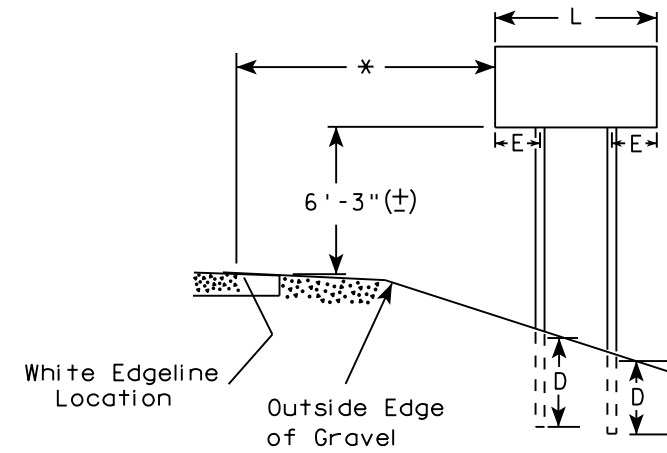

2' Min - 4' Max (See Note 6)

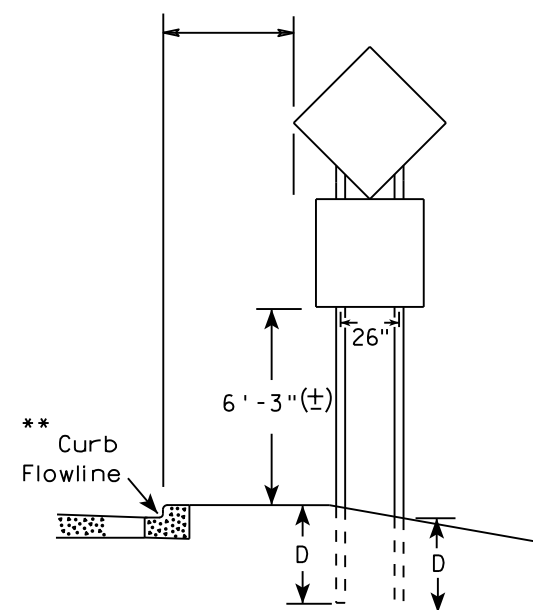

48" DIAMOND WARNING SIGN

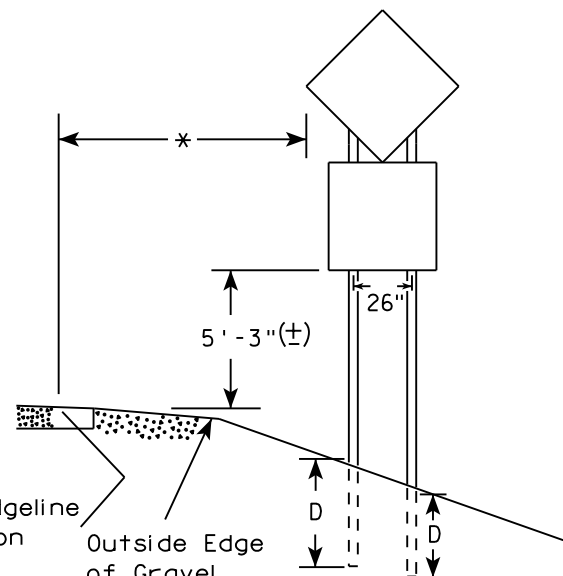

48" DIAMOND WARNING SIGN

\* 6 feet from edge of a paved shoulder or 12 feet from the edge of pavement (edge line location) or 2 feet from outside edge of gravel, whichever is greater unless directed by project engineer.

\*\* The existence of curb and gutter does not in itself mandate the vertical clearance illustrated. That height is typically measured where there is sidewalk adjacent to the roadway or parking is permitted. In the absence of sidewalk vertical clearance is measured from the top of the curb. Offset of signs is measured from the flow line.

\*\*\* See A4-3 sign plate for signs 4' or less in width and less than 20 S.F. in area.

SIGN SHAPE OTHER THAN DIAMOND (TWO POSTS REQUIRED)	
L	E
Greater than 48" Less than 60"	12"
60" to 108"	L/5

\*\*\*

SIGN SHAPE OTHER THAN DIAMOND (THREE POSTS REQUIRED)	
L	E
Greater than 108" to 144"	12"

POST EMBEDMENT DEPTH

Area of Sign Installation ( Sq. Ft. )	D ( Min )
20 or Less	4'
Greater than 20	5'

TYPICAL INSTALLATION OF TYPE II SIGNS ON MULTIPLE POSTS

WISCONSIN DEPT OF TRANSPORTATION  
 APPROVED *Matthew R. Rauch*  
 For State Traffic Engineer  
 DATE 8/21/17 PLATE NO. A4-4.15

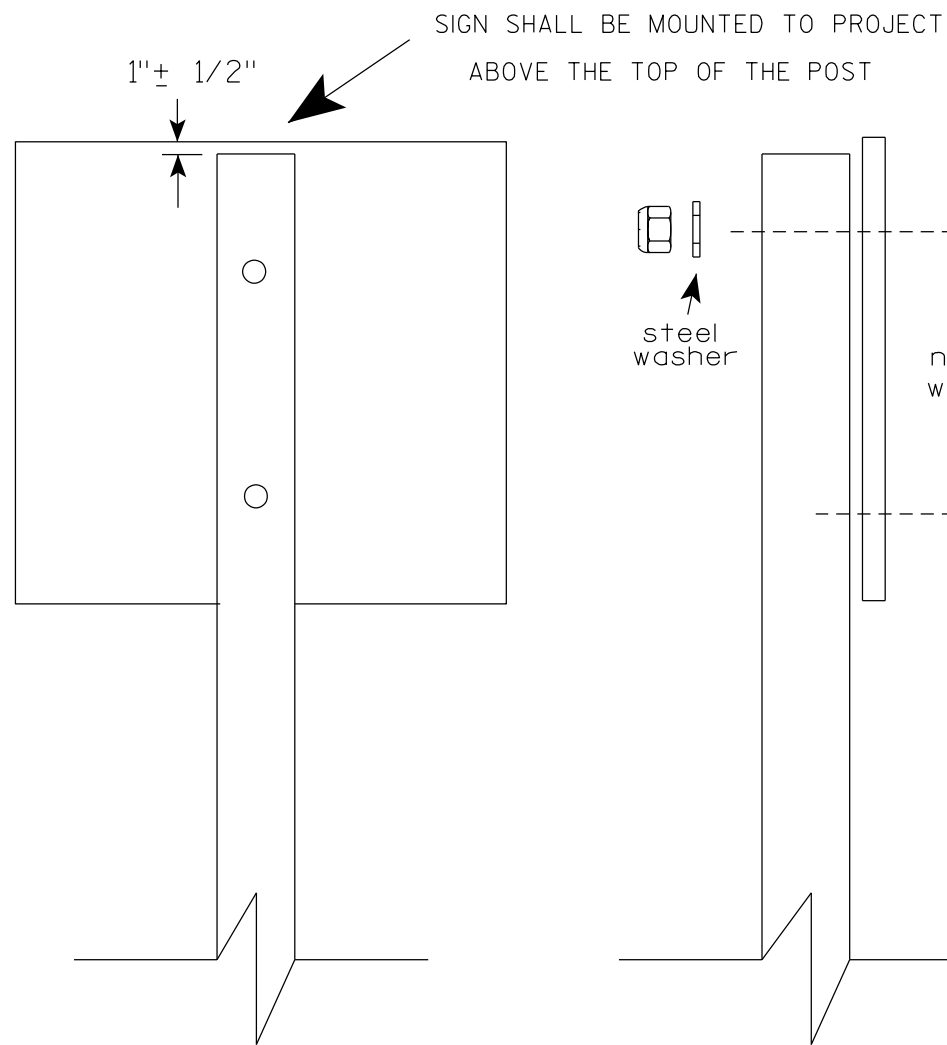

Nuts, bolts and lags used for mounting signs shall have hexagonal heads and shall be either :

- Hot dip galvanized in accordance with ASTM Designation: A 153, Class D, or SC 3
- Electro-galvanized in accordance with ASTM Designation : B 633, TYPE III, SC 3.

Threads on bolts and nuts shall be manufactured with sufficient allowance for the cadmium plate or galvanized coating to permit the nuts to run freely on the bolts.

- STRINGER BOLTING TO ALUMINUM SIGNS (SEE SIGN PLATE A4-18)
- MACHINE BOLTS -  $\frac{5}{16}$ " X 1-3/4" Length w/ lock nuts
- WOOD POSTS (4" x 6")
- LAG SCREWS -  $\frac{3}{8}$ " X 3" (NO STRINGERS ON BACK OF SIGN)
  - $\frac{3}{8}$ " X 4" (STRINGERS ON BACK OF SIGN)
- SQUARE STEEL POSTS (2" x 2")
- MACHINE BOLTS -  $\frac{3}{8}$ " X 3-1/4" Length w/ nuts (NO STRINGER ON BACK OF SIGN)
  - $\frac{3}{8}$ " X 5" Length w/ nuts (STRINGERS ON BACK OF SIGN)
- RIVETS -  $\frac{9}{32}$ " (6605-9-6) BULB-TITE, TRI-FOLD, ALUMINUM BODY/MANDREL
- O.D. FLANGE .720-.765 INCH, GRIP RANGE .042-.375 INCH
- WASHERS (ALL POSTS) -
- 1-1/4" O.D. X  $\frac{3}{8}$ " I.D. X  $\frac{1}{16}$ " STEEL
  - 1-1/4" O.D. X  $\frac{3}{8}$ " I.D. X .080 NYLON

\* Two different fastening systems are shown for illustration purposes. On any individual sign, either one or the other system shall be used. Actual number of fasteners per sign varies with the sign area, but normally there are two. For a single post installation, all signs greater than 9 sq. ft. require the use of 3 fasteners.

ATTACHMENT OF SIGNS TO POSTS	
WISCONSIN DEPT OF TRANSPORTATION	
APPROVED	<i>Matthew R Rauch</i> For State Traffic Engineer
DATE 4/1/2020	PLATE NO. A4-8.9

**TELESCOPIC TUBING ANCHORS  
TWO PIECE SYSTEM**

**2 1/4" SQUARE  
12 GAUGE  
PERFORATED  
GALVANIZED FINISH**

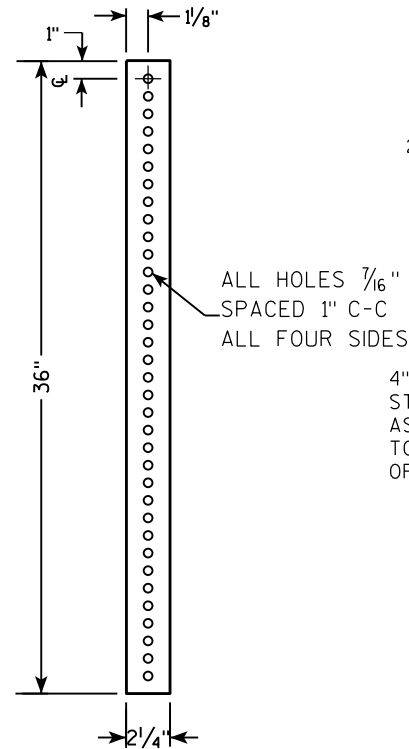

**2 1/2" SQUARE  
12 GAUGE  
OMNI-DIRECTIONAL  
PERFORATED  
SOIL STABILIZING SLEEVE  
GALVANIZED FINISH**

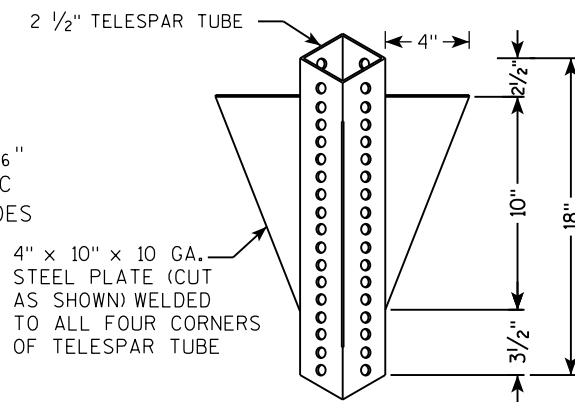

**DETAIL OF TUBULAR STEEL SIGN POST  
(IN POURED CONCRETE OR ASPHALT)**

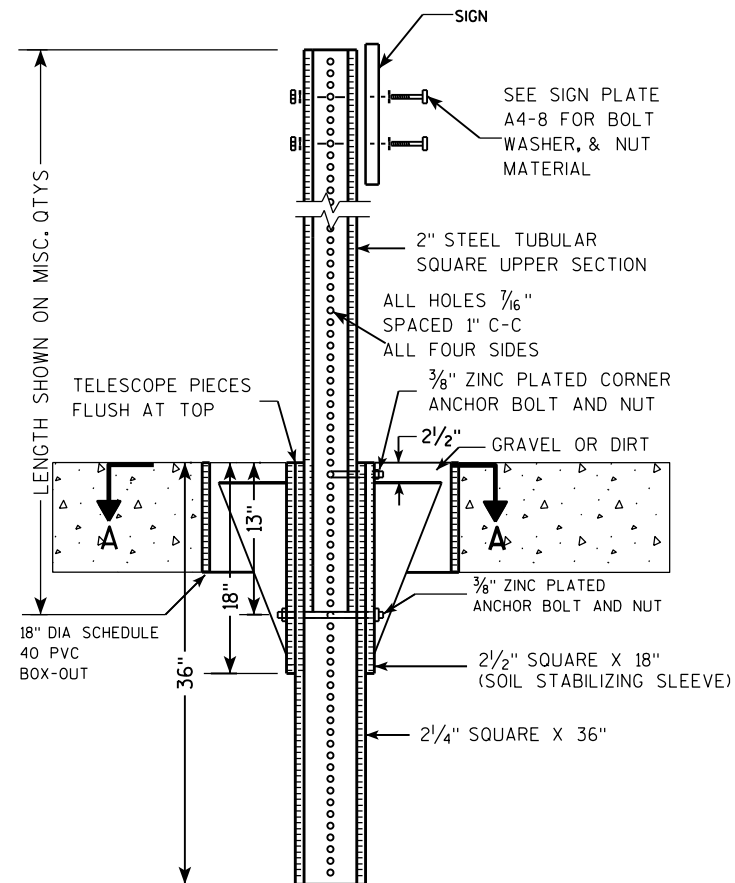

**DETAIL OF TUBULAR STEEL SIGN POST  
(IN LOCATIONS OTHER THAN POURED CONCRETE OR ASPHALT)**

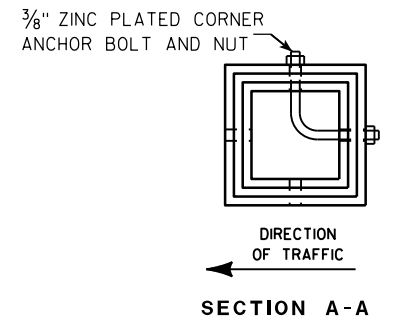
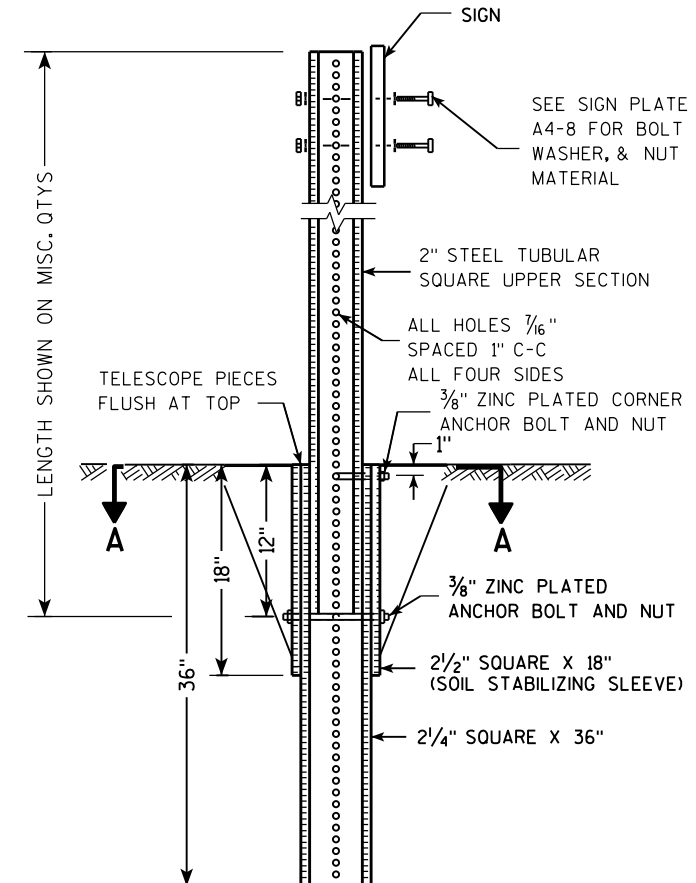

Area of Sign Installation (Sq. Ft.)	Number of Required Posts
9 or less	1
Greater than 9 less than or equal to 18	2
Greater than 18 less than or equal to 27	3

Signs wider than 3 feet or larger than 9 sq. ft shall be mounted on multiple posts (see above table).

**TUBULAR STEEL  
SIGN POST  
A4-9**

WISCONSIN DEPT OF TRANSPORTATION

APPROVED *Matthew R. Rauch*  
for State Traffic Engineer

DATE 2/05/15 PLATE NO. A4-9.9

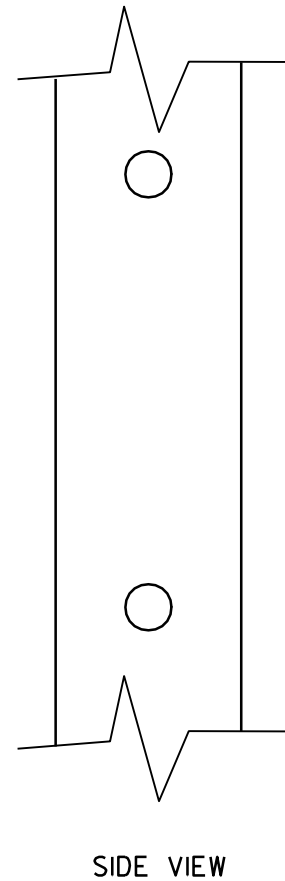
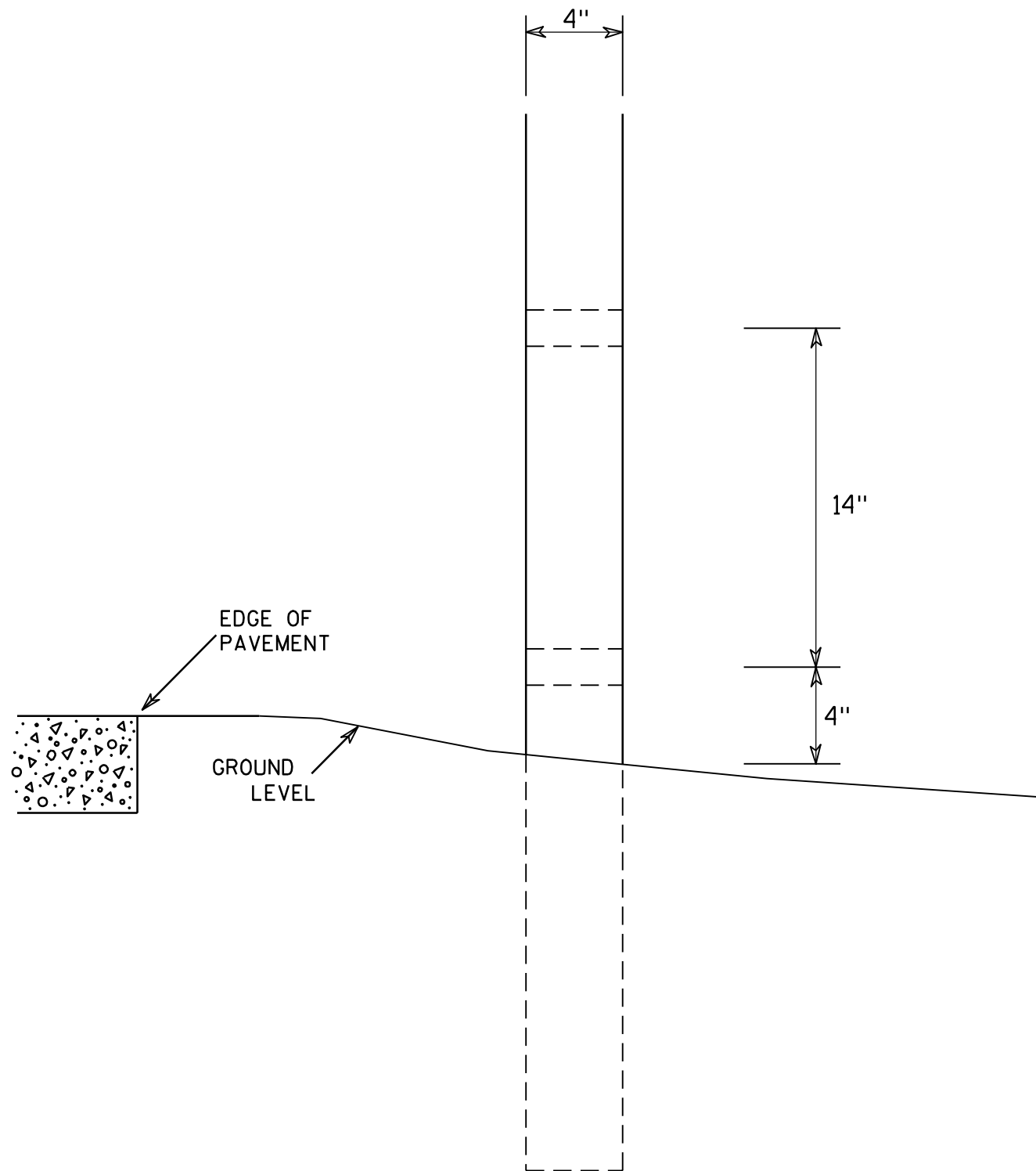

GENERAL NOTES

1. All 4 x 6 Wood Posts shall be modified by having two 1½" diameter holes drilled perpendicular to the roadway centerline.

7

7

<b>4 X 6 WOOD POST MODIFICATIONS</b>	
<i>WISCONSIN DEPT OF TRANSPORTATION</i>	
APPROVED	<i>Chester J Spang</i> for State Traffic Engineer
DATE <u>3/27/97</u>	PLATE NO. <u>A4-11.2</u>

# BANDING

SINGLE SIGN

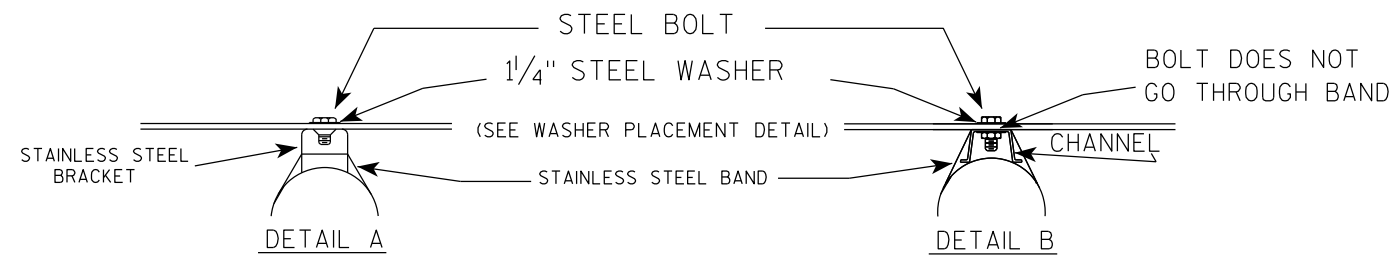
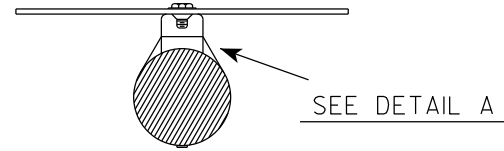
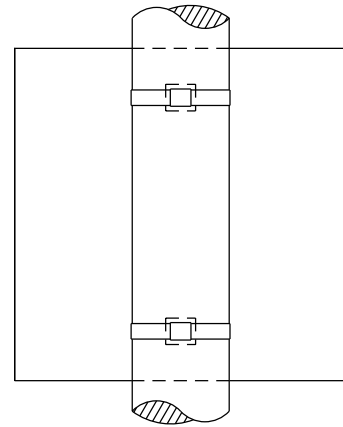

"J" ASSEMBLY

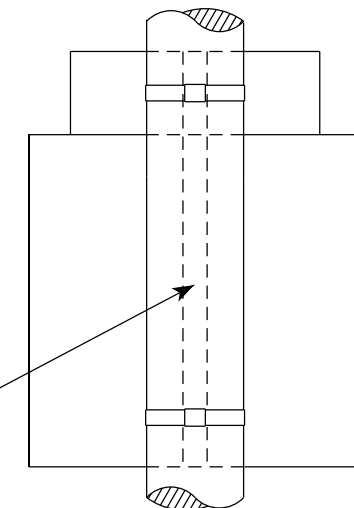

CHANNEL  
SEE TYPICAL PANEL  
INSTALLATION SHEET

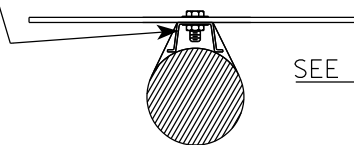

- GENERAL NOTES**
1. Any sign over 3 feet in width shall use the V-Block banding method. See A5-10 standard plate.
  2. Signs 3 feet or greater in height shall have three bracket bands installed. Signs less than 3 feet in height shall have two bracket bands installed.
  3. Banding and assembly bracket shall be stainless steel. All bands shall be 3/4" in width and 0.025" thickness.
  4. ALL SIGN MOUNTING BOLTS AND WASHERS SHALL BE EITHER:
    - a. Hot dip or mechanically galvanized in accordance with ASTM Designation: A 153, Class D
    - b. Electro-galvanized in accordance with ASTM designation: B 633, Type III, SC 3

WASHER PLACEMENT

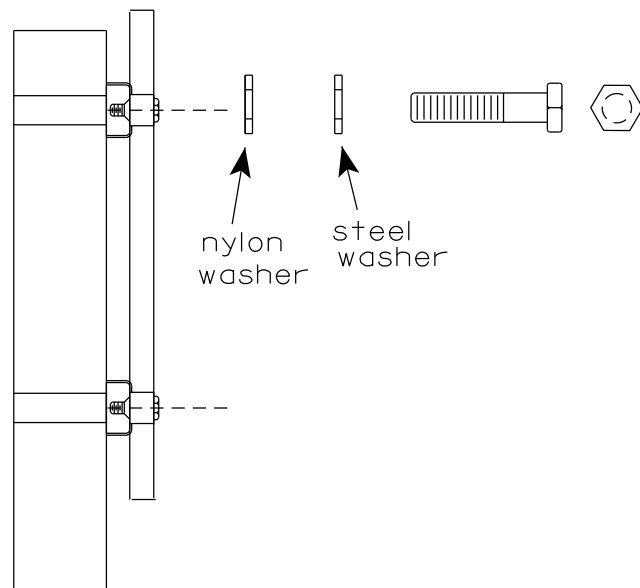

WASHERS (ALL POSTS) -  
 1-1/4" O.D. X 3/8" I.D. X 1/16" STEEL  
 1-1/4" O.D. X 3/8" I.D. X .080 NYLON  
 FOR ALL TYPE H SIGNS

STANDARD SIGN  
SIGN BANDING DETAILS

WISCONSIN DEPT OF TRANSPORTATION

APPROVED *Matthew R. Rauch*  
for State Traffic Engineer

DATE 6/10/19 PLATE NO. A5-9.4

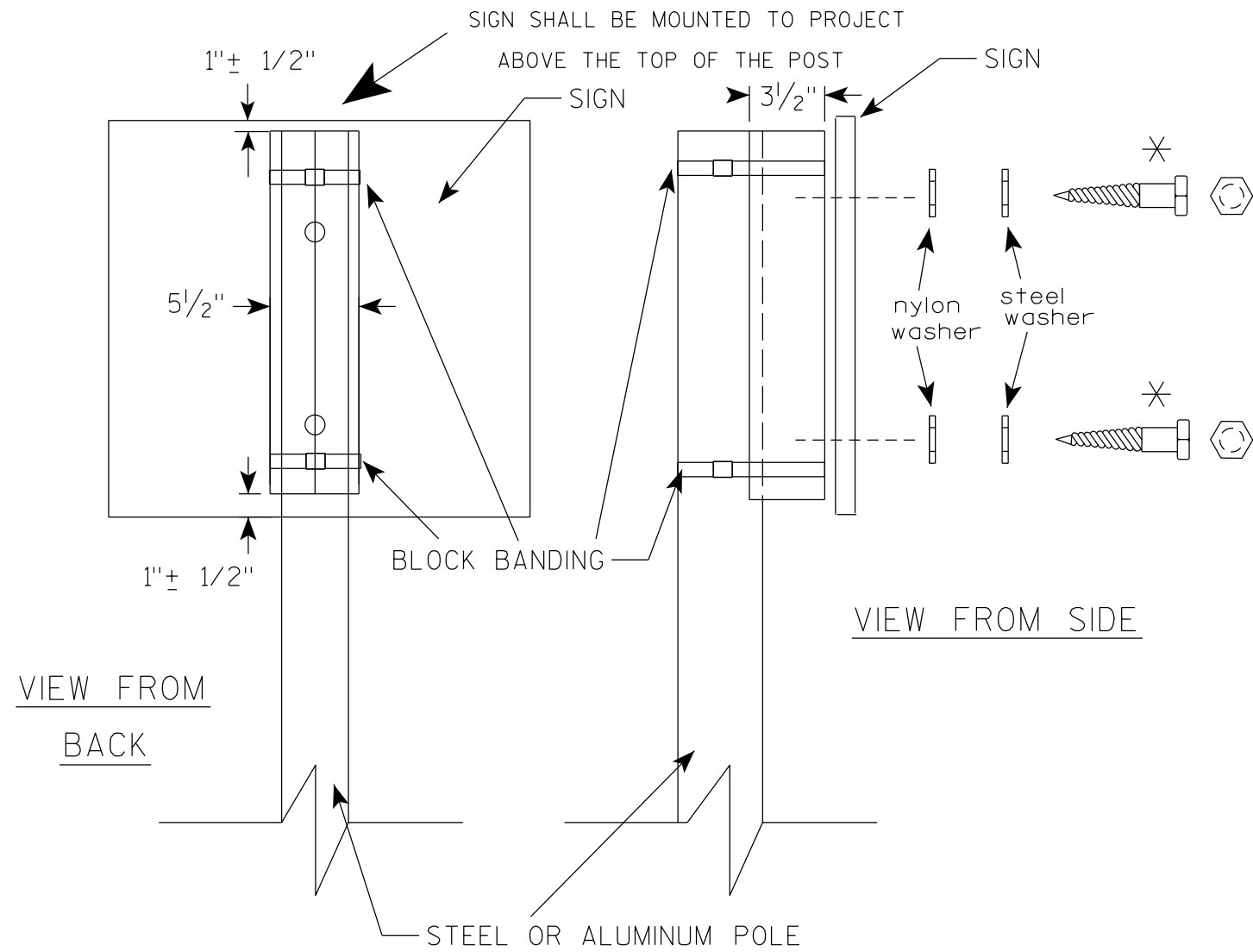

VIEW FROM  
BACK

VIEW FROM SIDE

STEEL OR ALUMINUM POLE

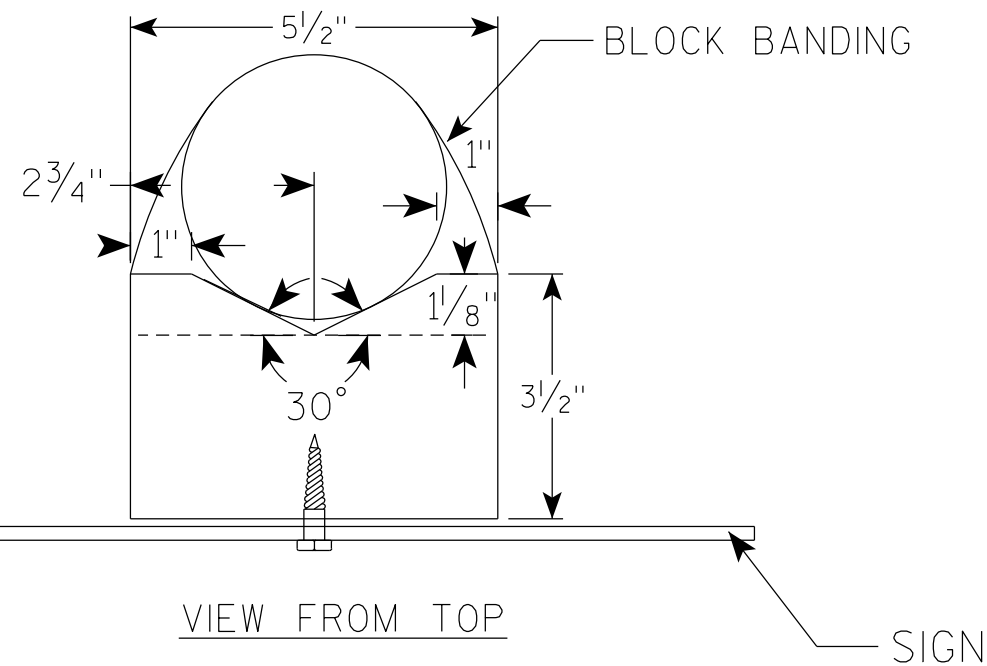

### GENERAL NOTES

1. WOOD 4"X6" POST MATERIAL SHALL CONFORM TO 507.2.2 OF THE WISDOT STANDARD SPECIFICATIONS
2. BLOCK BANDING AND CLIPS SHALL BE STAINLESS STEEL, 3/4" WIDTH AND 0.025" THICKNESS
3. SIGNS 3' OR GREATER IN HEIGHT SHALL UTILIZE 3 BLOCK BANDS. SIGNS UNDER 3' IN HEIGHT SHALL UTILIZE 2 BLOCK BANDS
4. ACTUAL NUMBER OF FASTENERS PER SIGN VARIES WITH THE SIGN AREA, BUT NORMALLY THERE ARE TWO. FOR SIGNS GREATER THAN 9 S.F. 3 FASTENERS SHALL BE USED.
5. ALL SIGN MOUNTING BOLTS AND WASHERS SHALL BE EITHER:
  - a. Hot dip or mechanically galvanized in accordance with ASTM Designation: A 153, Class D
  - b. Electro-galvanized in accordance with ASTM Designation : B 633, TYPE III, SC 3
6. ALL BOLTS SHALL HAVE HEXAGONAL HEADS.
7. STEEL WASHERS SHALL BE 1/4" O.D. X 3/8" I.D. X 1/16"
8. NYLON WASHERS SHALL BE 1/4" O.D. X 3/8" I.D. X .080 FOR TYPE H OR TYPE F FACE SIGN

✱ LAG BOLTS SHALL BE 3/8" X 2 1/2"

BLOCK BANDING DETAIL  
( V-BLOCK OPTION )

WISCONSIN DEPT OF TRANSPORTATION

APPROVED *Matthew R. Rauch*  
for State Traffic Engineer

DATE 4/19/2022 PLATE NO. A5-10.3

PROJECT NO:

SHEET NO:

E

**NOTES**

1. Sign is Type II - see Note 7 - reference WIS DOT Standard Specification for HIGHWAY and STRUCTURE CONSTRUCTION latest edition.
2. Color:  
Background - White & Black - See Note 7  
Message - Black
3. Message Series - see Note 5
4. Corners may be square or rounded when base material is plywood but borders shall be rounded as shown. When base material is metal, the corners and borders shall be rounded.
5. Message Series E for 1 letter.  
Message Series D for 2 letters unless message is too big then Series C.  
Message Series C for 3 letters unless message is too big then Series B.
6. Substitute appropriate letters & optically center to achieve proper balance.
7. Permanent Signs  
Background - Type H Reflective  
Detour or temporary Signs  
Background - Reflective

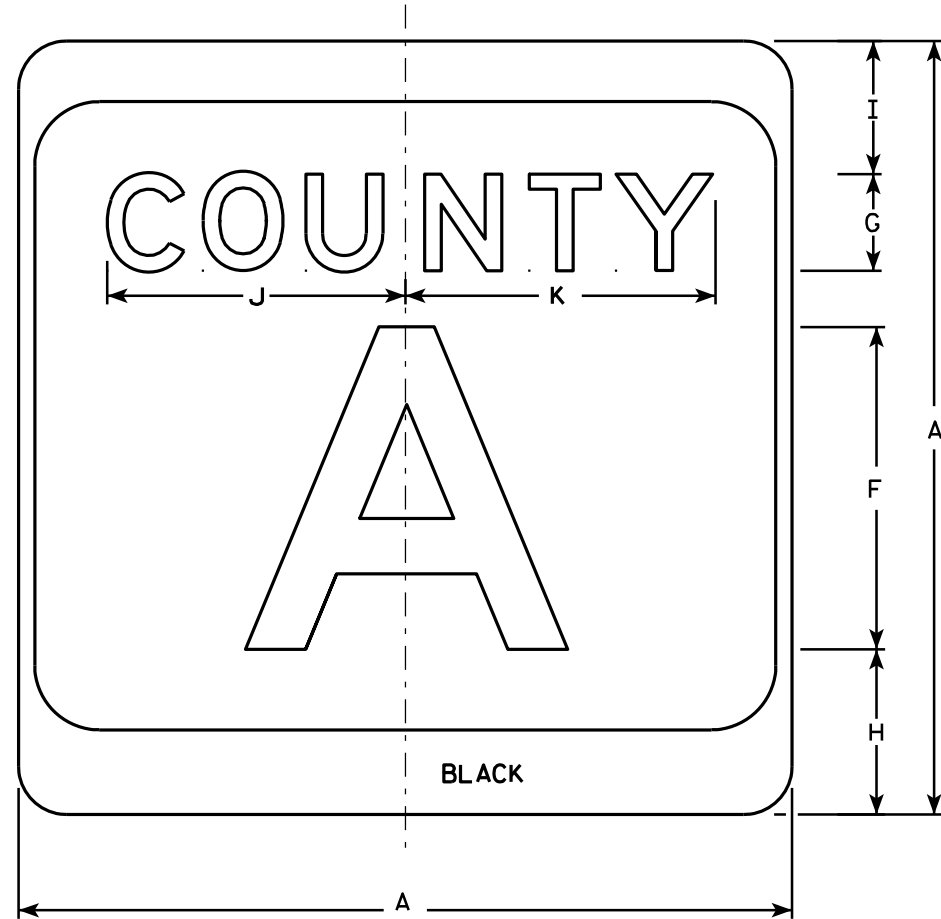

M1-5A

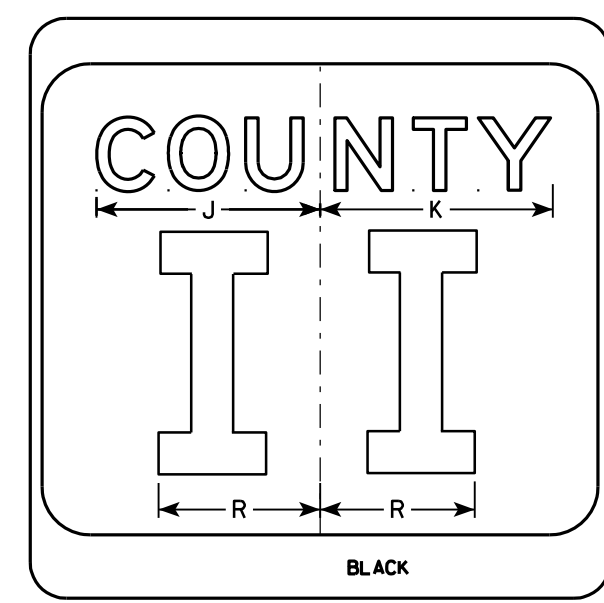
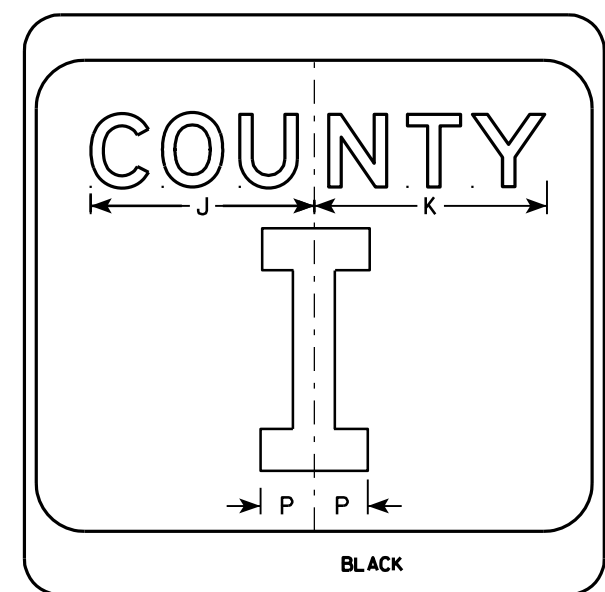
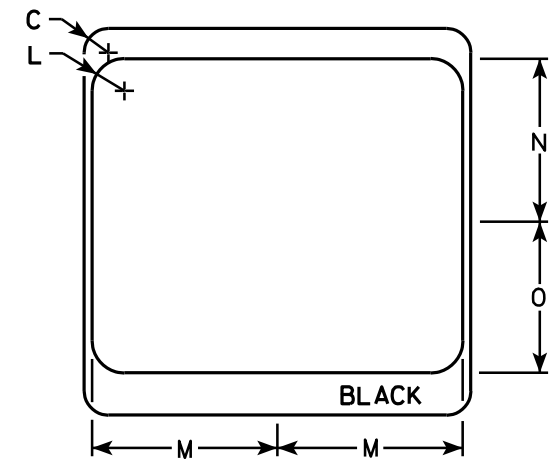

7

7

SIZE	A	B	C	D	E	F	G	H	I	J	K	L	M	N	O	P	Q	R	S	T	U	V	W	X	Y	Z	Area sq. ft.
1																											
2	24		1 1/2			10	3	5 1/8	4 1/8	9 1/4	9 5/8	2	11 1/2	10 1/8	9 3/8	2 1/4		6 5/8									4.0
3	36		2 1/4			16	4	7 5/8	5 5/8	12 1/4	12 7/8	3	17 1/8	15 1/4	14	3 3/8		10									9.0
4	36		2 1/4			16	4	7 5/8	5 5/8	12 1/4	12 7/8	3	17 1/8	15 1/4	14	3 3/8		10									9.0
5	36		2 1/4			16	4	7 5/8	5 5/8	12 1/4	12 7/8	3	17 1/8	15 1/4	14	3 3/8		10									9.0

**CTH MARKER**  
**M1-5A FOR ASSEMBLIES**

WISCONSIN DEPT OF TRANSPORTATION

APPROVED *Matthew R. Raub*  
For State Traffic Engineer

DATE 9/27/11 PLATE NO. MI-5A.8

PROJECT NO: \_\_\_\_\_ HWY: \_\_\_\_\_ COUNTY: \_\_\_\_\_ SHEET NO: **E**

NOTES

1. Sign is Type II - Type F Reflective - reference WIS DOT Standard Specification for HIGHWAY and STRUCTURE CONSTRUCTION latest edition.
2. Color:  
Background - Orange  
Message - Black
3. Message Series - B
4. Corners may be square or rounded when base material is plywood but borders shall be rounded as shown. When base material is metal, the corners and borders shall be rounded.

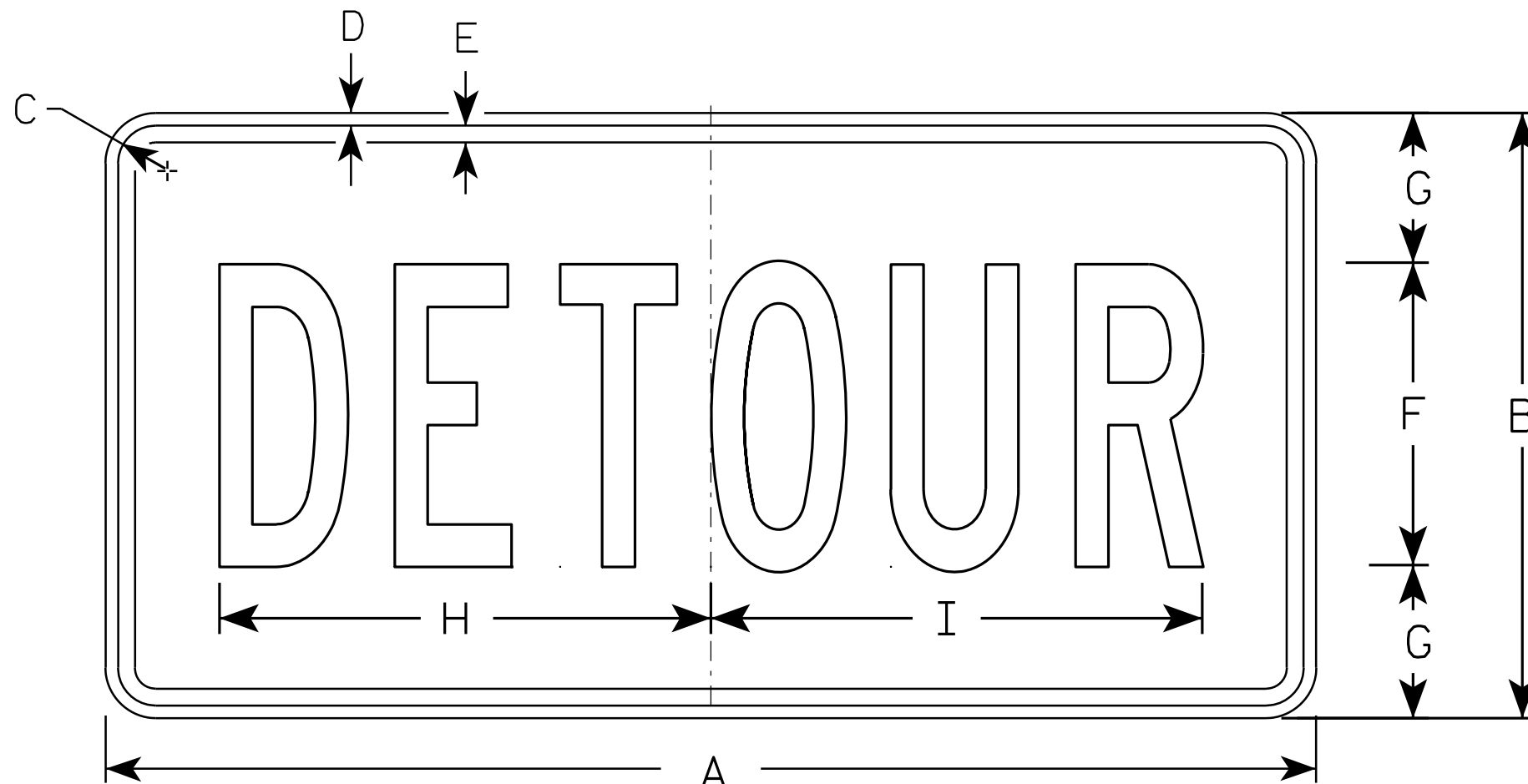

M4-8

7

7

SIZE	A	B	C	D	E	F	G	H	I	J	K	L	M	N	O	P	Q	R	S	T	U	V	W	X	Y	Z	Area sq. ft.
1																											
2	24	12	1 1/8	3/8	3/8	6	3	10	10 1/4																		2.0
3	36	18	1 1/8	3/8	1/2	9	4 1/2	14 5/8	14 1/2																		4.5
4																											
5																											

STANDARD SIGN  
M4-8

WISCONSIN DEPT OF TRANSPORTATION

APPROVED *Matthew R. Rauch*  
for State Traffic Engineer

DATE 11/10/10 PLATE NO. M4-8.2

PROJECT NO: \_\_\_\_\_ HWY: \_\_\_\_\_ COUNTY: \_\_\_\_\_ SHEET NO: **E**



NOTES

1. Sign is Type II - Type F Reflective - reference WIS DOT Standard Specification for HIGHWAY and STRUCTURE CONSTRUCTION latest edition.
2. Color:  
Background - Orange  
Message - Black
3. Message Series - B
4. Corners may be square or rounded when base material is plywood but borders shall be rounded as shown. When base material is metal, the corners and borders shall be rounded.

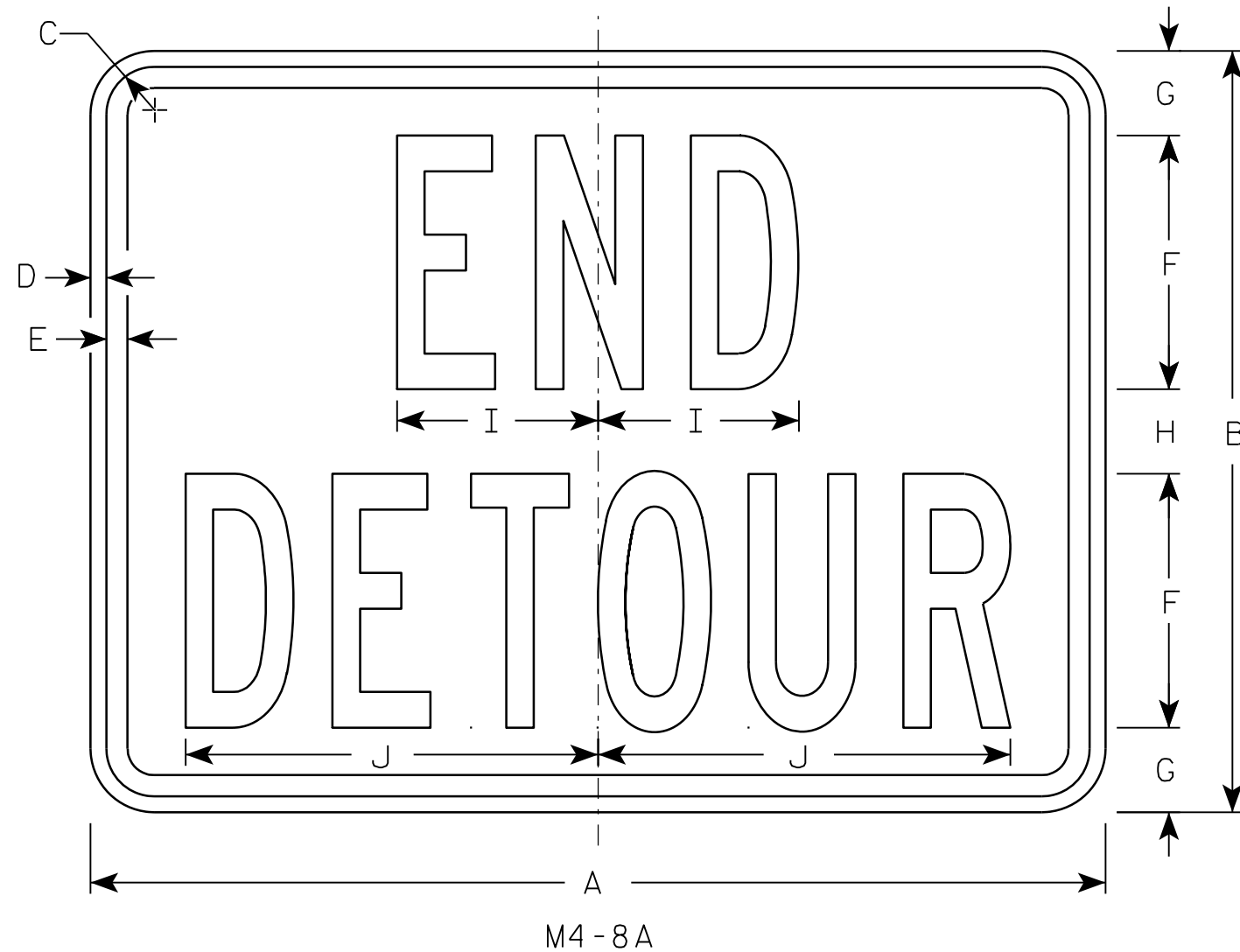

7

7

SIZE	A	B	C	D	E	F	G	H	I	J	K	L	M	N	O	P	Q	R	S	T	U	V	W	X	Y	Z	Area sq. ft.
1																											
2	24	18	1 1/8	3/8	1/2	6	2	2	4 3/4	9 3/4																	3.0
3	30	24	1 1/8	3/8	1/2	8	2 1/2	3	6 3/4	13																	5.0
4																											
5																											

STANDARD SIGN  
M4-8A

WISCONSIN DEPT OF TRANSPORTATION

APPROVED *Matthew R. Rauch*  
for State Traffic Engineer

DATE 3/9/11 PLATE NO. M4-8A.2

PROJECT NO: \_\_\_\_\_ HWY: \_\_\_\_\_ COUNTY: \_\_\_\_\_ SHEET NO: **E**

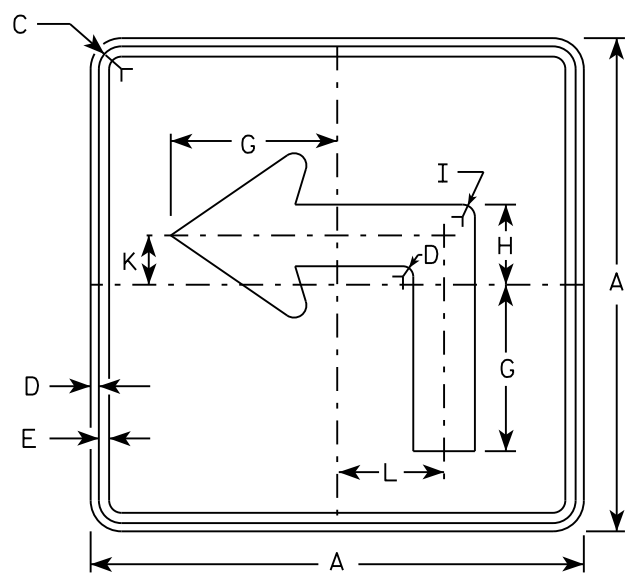

M5-1L  
MM5-1L  
M05-1L  
MP5-1L

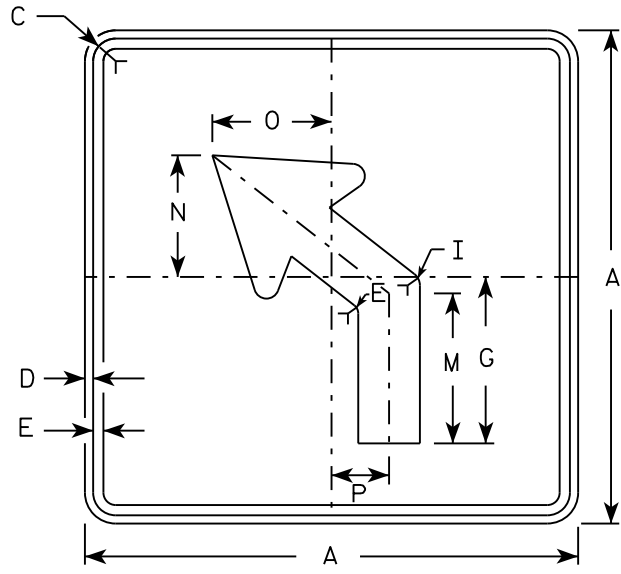

M5-2L  
MM5-2L  
M05-2L  
MP5-2L

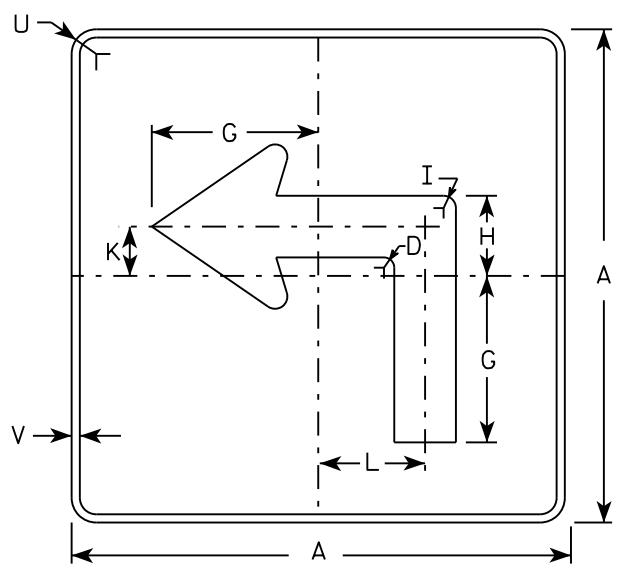

MB5-1L  
MK5-1L  
MN5-1L  
MR5-1L

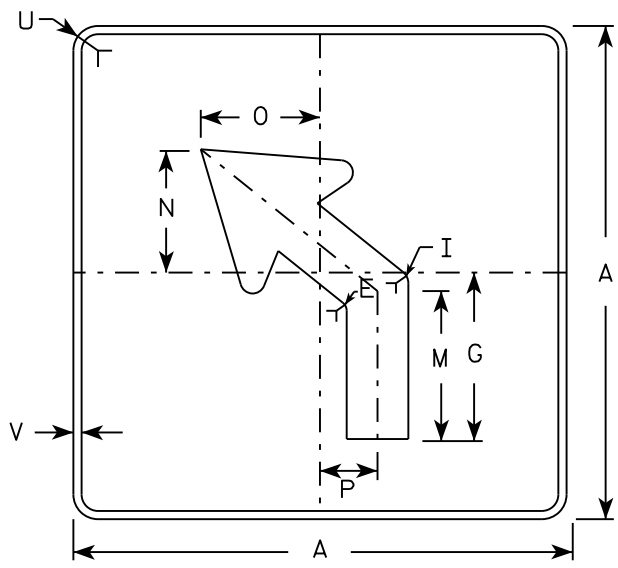

MB5-2L  
MK5-2L  
MN5-2L  
MR5-2L

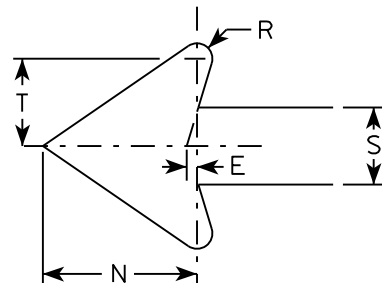

NOTES

- Signs are Type II - Type H reflective except as shown
- Color:
  - Background - See note 4
  - Message - See note 4
- Corners may be square or rounded when base material is plywood but borders shall be rounded as shown. When base material is metal, the corners and borders shall be rounded.
- M5-1 and M5-2 Background - White  
Message - Black
  - MB5-1 and MB5-2 Background - Blue  
Message - White
  - MK5-1 and MK5-2 Background - Green  
Message - White
  - MM5-1 and MM5-2 Background - White  
Message - Green
  - MN5-1 and MN5-2 Background - Brown  
Message - White
  - M05-1 and M05-2 Background - Orange - Type F Reflective  
Message - Black
  - MP5-1 and MP5-2 Background - White - Type H Reflective  
Message - Blue
  - MR5-1 and MR5-2 Background - Brown  
Message - Yellow
- M5-1R same as M5-1L except arrow points right.
- M5-2R same as M5-2L except arrow tilts right.

SIZE	A	B	C	D	E	F	G	H	I	J	K	L	M	N	O	P	Q	R	S	T	U	V	W	X	Y	Z	Area sq. ft.
1																											
2	21		1 1/8	3/8	3/8		7	3 3/8	5/8		2 1/8	4 1/2	6 3/8	5 1/4	5	2 1/2		1/2	2 5/8	3	1 1/2	1/2					3.06
3	30		1 3/8	1/2	5/8		10 1/8	4 7/8	7/8		3	6 1/2	9 1/8	7 1/2	7 1/4	3 1/2		3/4	3 3/4	4 1/4	1 7/8	1/2					6.25
4	30		1 3/8	1/2	5/8		10 1/8	4 7/8	7/8		3	6 1/2	9 1/8	7 1/2	7 1/4	3 1/2		3/4	3 3/4	4 1/4	1 7/8	1/2					6.25
5	30		1 3/8	1/2	5/8		10 1/8	4 7/8	7/8		3	6 1/2	9 1/8	7 1/2	7 1/4	3 1/2		3/4	3 3/4	4 1/4	1 7/8	1/2					6.25

STANDARD SIGN  
M5-1 & M5-2

WISCONSIN DEPT OF TRANSPORTATION

APPROVED *Matthew R. Rauch*  
for State Traffic Engineer

DATE 10/15/15 PLATE NO. M5-1.13

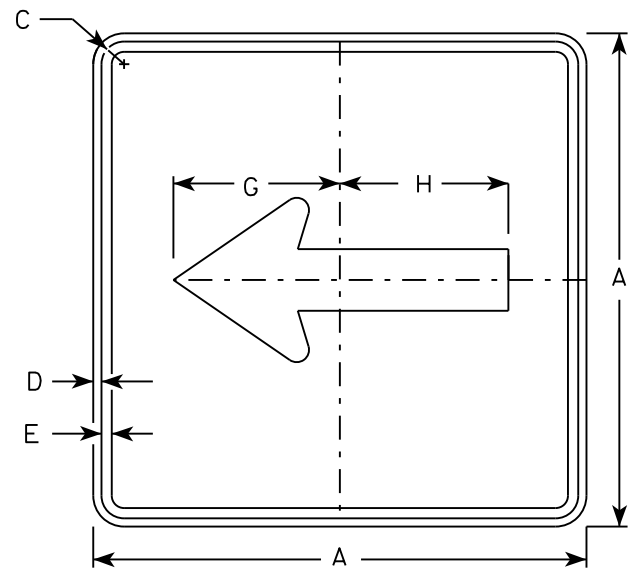

M6-1  
MM6-1  
M06-1  
MP6-1

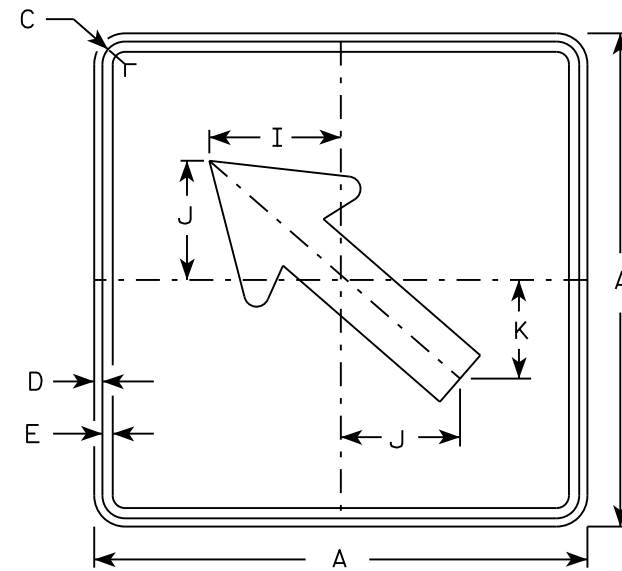

M6-2  
MM6-2  
M06-2  
MP6-2

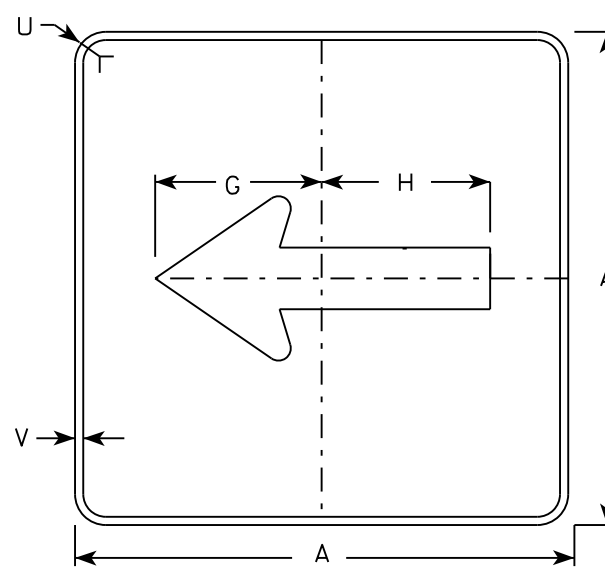

MB6-1  
MK6-1  
MN6-1  
MR6-1

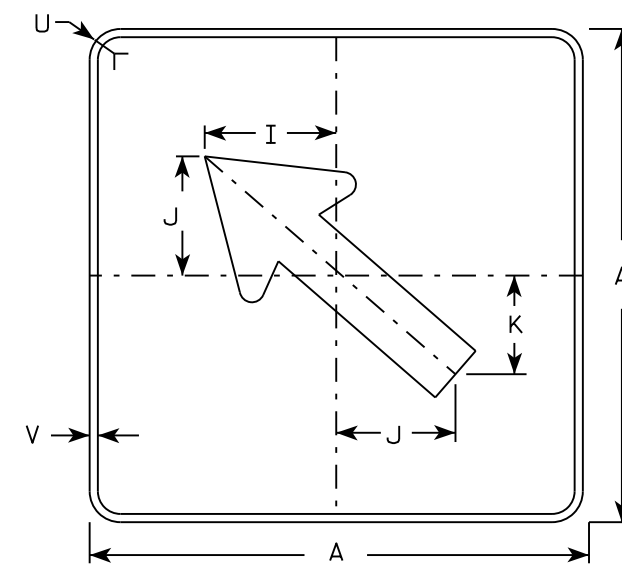

MB6-2  
MK6-2  
MN6-2  
MR6-2

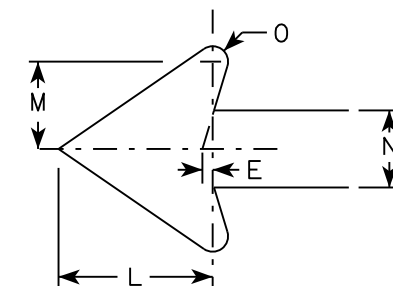

NOTES

- Signs are Type II - Type H except as Shown
- Color:  
Background - See note 4  
Message - See note 4
- Corners may be square or rounded when base material is plywood but borders shall be rounded as shown. When base material is metal, the corners and borders shall be rounded.
- M6-1 and M6-2 Background - White  
Message - Black  
MB6-1 and MB6-2 Background - Blue  
Message - White  
MK6-1 and MK6-2 Background - Green  
Message - White  
MM6-1 and MM6-2 Background - White  
Message - Green  
MN6-1 and MN6-2 Background - Brown  
Message - White  
M06-1 and M06-2 Background - Orange - Type F Reflective  
Message - Black  
MP6-1 and MP6-2 Background - White  
Message - Blue  
MR6-1 and MR6-2 Background - Brown  
Message - Yellow

7

SIZE	A	B	C	D	E	F	G	H	I	J	K	L	M	N	O	P	Q	R	S	T	U	V	W	X	Y	Z	Area sq. ft.
1																											
2	21		1 1/8	3/8	3/8		7 1/2	7 1/8	5 5/8	5	4 1/4	5 1/4	3	2 5/8	1/2						1 1/2	1/2					3.06
3	30		1 3/8	1/2	5/8		10 3/4	10 1/4	8	7 1/4	6	7 1/2	4 1/4	3 3/4	3/4						1 7/8	1/2					6.25
4	30		1 3/8	1/2	5/8		10 3/4	10 1/4	8	7 1/4	6	7 1/2	4 1/4	3 3/4	3/4						1 7/8	1/2					6.25
5	30		1 3/8	1/2	5/8		10 3/4	10 1/4	8	7 1/4	6	7 1/2	4 1/4	3 3/4	3/4						1 7/8	1/2					6.25

STANDARD SIGN  
M6-1 & M6-2  
SERIES

WISCONSIN DEPT OF TRANSPORTATION

APPROVED *Matthew R. Rauch*  
for State Traffic Engineer

DATE 10/15/15 PLATE NO. M6-1.15

NOTES

1. Sign is Type II - Type H Reflective
2. Color:  
Background - White  
Message - Black
3. Message Series - C
4. Corners may be square or rounded when base material is plywood but borders shall be rounded as shown. When base material is metal, the corners and borders shall be rounded.
5. Substitute appropriate numerals to nearest quarter mile and optically adjust spacing to achieve proper balance.

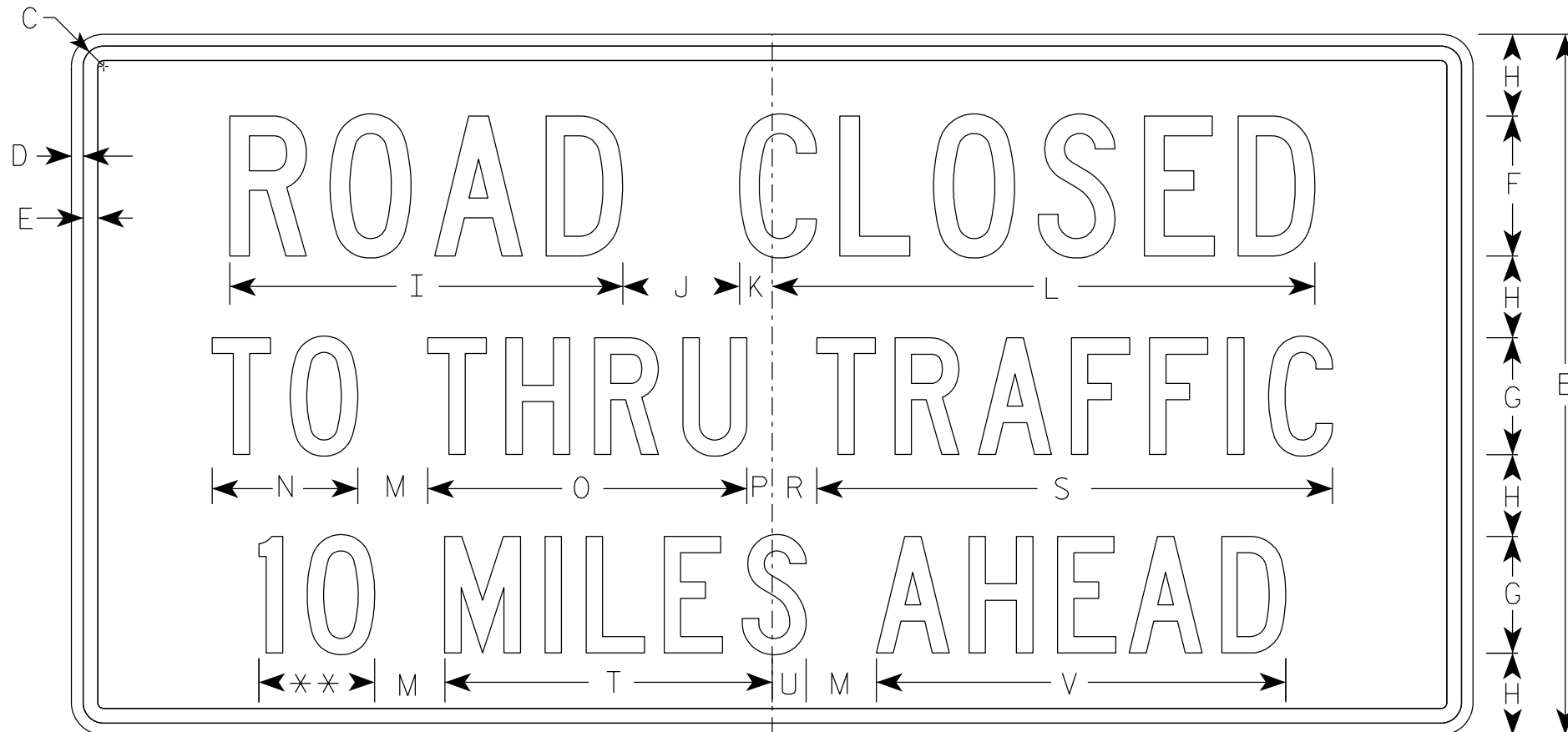

R11-3

\*\* See Note 5

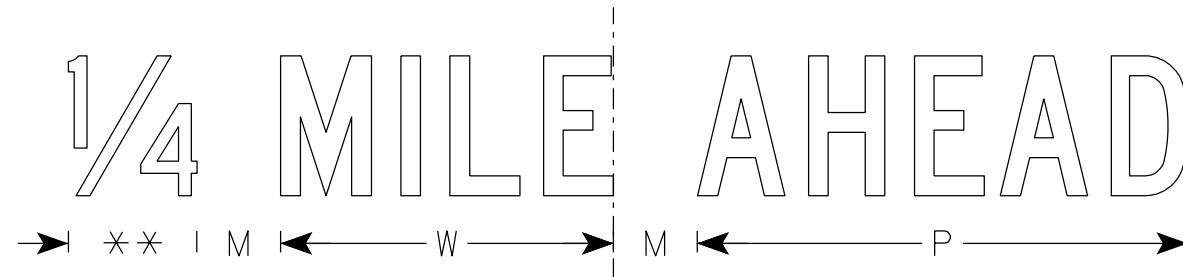

SIZE	A	B	C	D	E	F	G	H	I	J	K	L	M	N	O	P	Q	R	S	T	U	V	W	X	Y	Z	Area sq. ft.	
1	36	18	1 1/4	3/8	3/8	4	3	2	11 1/4	3	1 1/8	15 3/8	2	3 3/4	8 1/4	5/8		1 3/8	13 1/4	8 3/8	7/8	10 1/2	7 1/8				4.5	
2S	60	30	1 3/8	1/2	5/8	6	5	3 1/2	16 7/8	5	1 3/8	23 1/4	3	6 1/4	13 5/8	1 1/8		1 7/8	22 1/8	14	1 1/2	17 1/2	11 7/8				12.5	
2M	60	30	1 3/8	1/2	5/8	6	5	3 1/2	16 7/8	5	1 3/8	23 1/4	3	6 1/4	13 5/8	1 1/8		1 7/8	22 1/8	14	1 1/2	17 1/2	11 7/8				12.5	
3																												
4																												
5																												

STANDARD SIGN  
R11-3

WISCONSIN DEPT OF TRANSPORTATION

APPROVED *Matthew R. Rauch*  
for State Traffic Engineer

DATE 6/14/2021 PLATE NO. R11-3.9

PROJECT NO: \_\_\_\_\_ HWY: \_\_\_\_\_ COUNTY: \_\_\_\_\_ SHEET NO: \_\_\_\_\_ **E**

NOTES

1. Sign is Type II - Type H Reflective - reference WIS DOT Standard Specification for HIGHWAY and STRUCTURE CONSTRUCTION latest edition.
2. Color:  
Background - White  
Message - Black
3. Message Series - C
4. Corners may be square or rounded when base material is plywood but borders shall be rounded as shown. When base material is metal, the corners and borders shall be rounded.

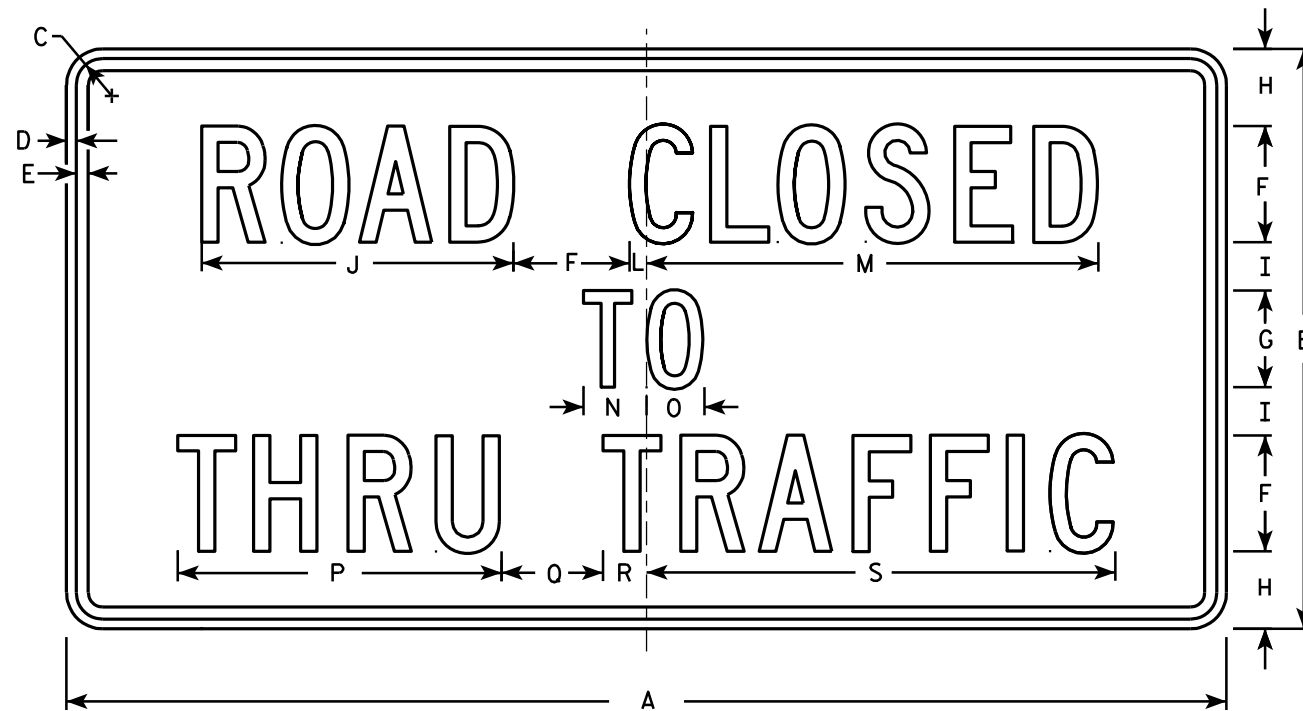

R11-4

7

7

SIZE	A	B	C	D	E	F	G	H	I	J	K	L	M	N	O	P	Q	R	S	T	U	V	W	X	Y	Z	Area sq. ft.
1																											
2S	60	30	1 3/8	1/2	5/8	6	5	4	2 1/2	16 1/8		7/8	23 3/8	3 1/4	3	16 3/4	5 1/4	2 1/4	24 1/4								12.5
2M	60	30	1 3/8	1/2	5/8	6	5	4	2 1/2	16 1/8		7/8	23 3/8	3 1/4	3	16 3/4	5 1/4	2 1/4	24 1/4								12.5
3																											
4																											
5																											

**STANDARD SIGN**  
R11 - 4

---

WISCONSIN DEPT OF TRANSPORTATION

APPROVED *Matthew R. Raush*  
for State Traffic Engineer

DATE 4/1/11 PLATE NO. R11-4.3

PROJECT NO: \_\_\_\_\_ HWY: \_\_\_\_\_ COUNTY: \_\_\_\_\_ SHEET NO: \_\_\_\_\_ E

**NOTES**

1. Sign is Type II - Type F Reflective
2. Color:  
Background - Orange  
Message - Black
3. Message Series - C
4. Corners may be square or rounded when base material is plywood but borders shall be rounded as shown. When base material is metal, the corners and borders shall be rounded.

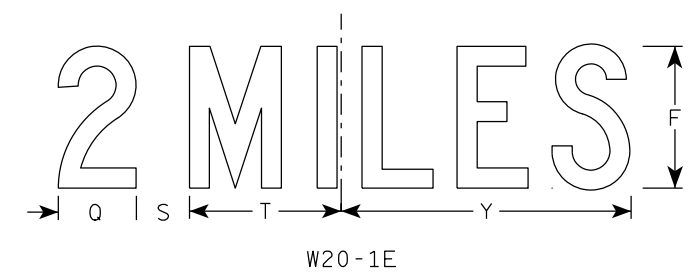
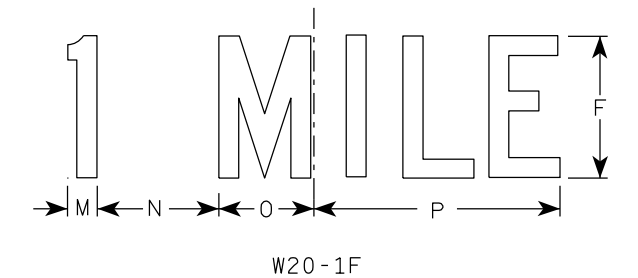
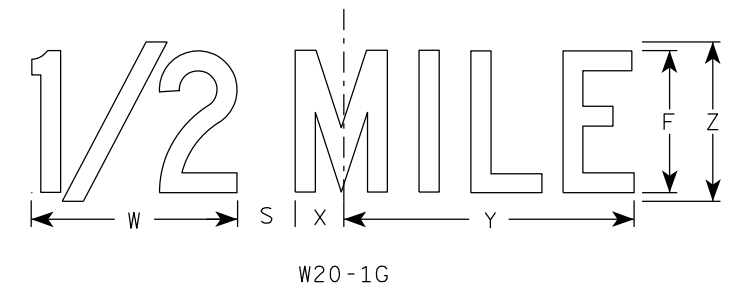
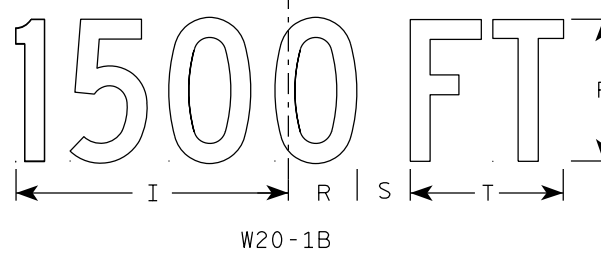
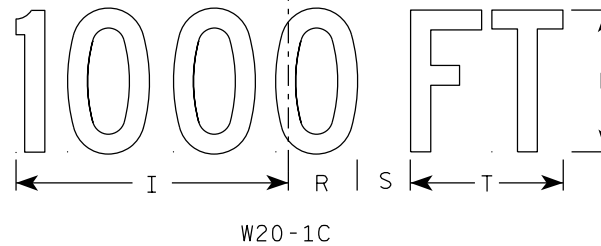
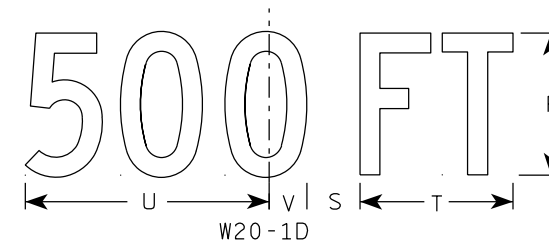
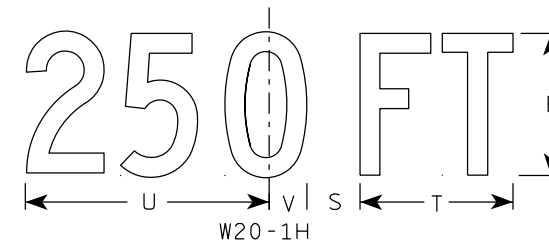
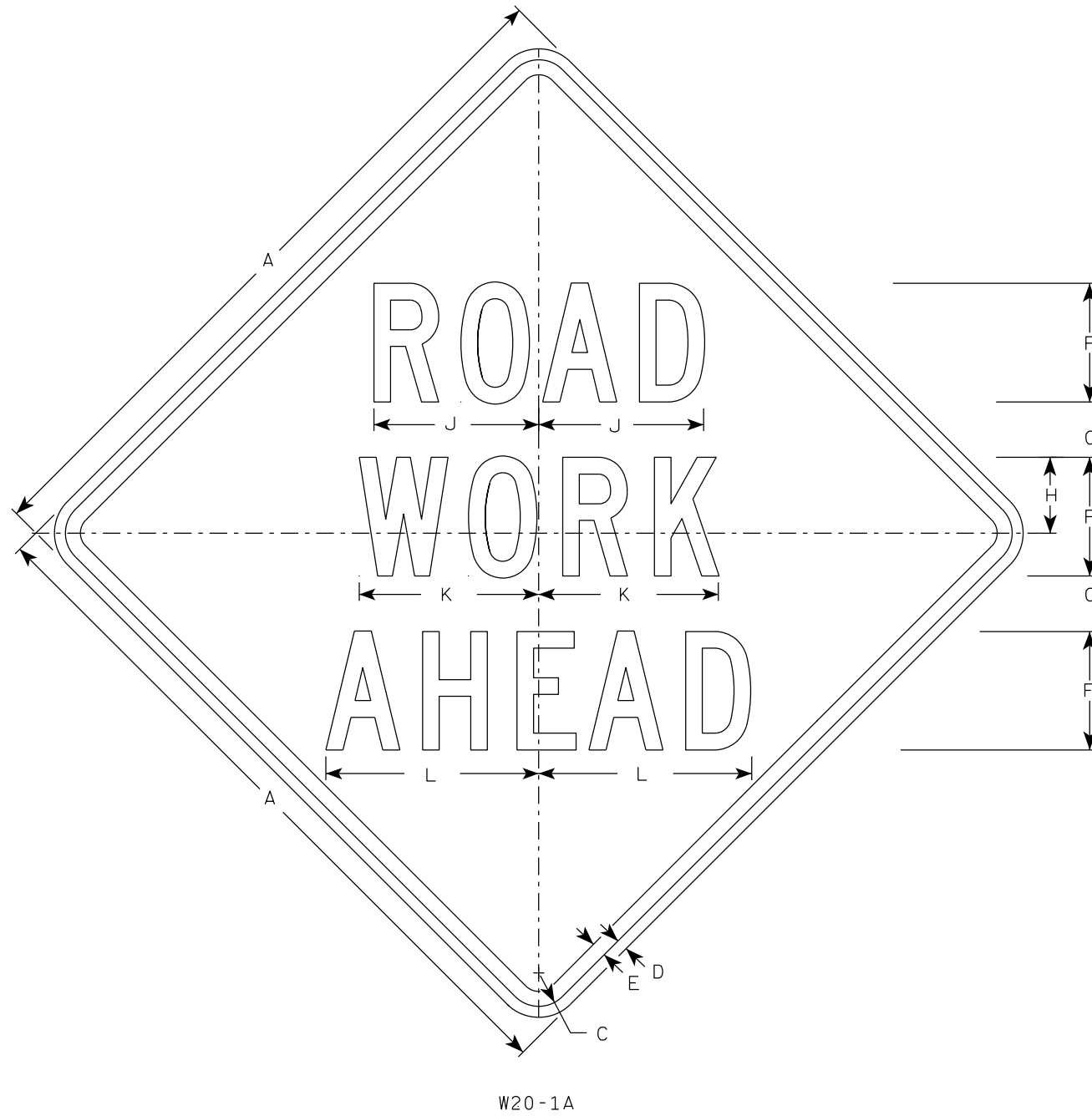

W20-1A

W20-1C

W20-1B

W20-1G

W20-1F

W20-1E

SIZE	A	B	C	D	E	F	G	H	I	J	K	L	M	N	O	P	Q	R	S	T	U	V	W	X	Y	Z	Area sq. ft.
1	36		1 5/8	5/8	3/4	5	2 5/8	3 1/4	10 1/8	7	7 5/8	8 7/8	1 1/8	4 1/2	3 1/2	9	3 1/4	2 1/2	2 1/4	5 5/8	9	1 3/8	8	1 3/4	10 3/4	6	9.0
2S	48		2 1/4	3/4	1	8	3 3/4	5 1/8	15 3/8	11 1/8	12 1/8	14 3/8	1 5/8	6 7/8	5 3/8	13 7/8	4 3/8	3 7/8	3	8 5/8	13 3/4	2 1/8	11 7/8	2 3/4	16 3/8	9	16.0
2M	48		2 1/4	3/4	1	8	3 3/4	5 1/8	15 3/8	11 1/8	12 1/8	14 3/8	1 5/8	6 7/8	5 3/8	13 7/8	4 3/8	3 7/8	3	8 5/8	13 3/4	2 1/8	11 7/8	2 3/4	16 3/8	9	16.0
3	48		2 1/4	3/4	1	8	3 3/4	5 1/8	15 3/8	11 1/8	12 1/8	14 3/8	1 5/8	6 7/8	5 3/8	13 7/8	4 3/8	3 7/8	3	8 5/8	13 3/4	2 1/8	11 7/8	2 3/4	16 3/8	9	16.0
4	48		2 1/4	3/4	1	8	3 3/4	5 1/8	15 3/8	11 1/8	12 1/8	14 3/8	1 5/8	6 7/8	5 3/8	13 7/8	4 3/8	3 7/8	3	8 5/8	13 3/4	2 1/8	11 7/8	2 3/4	16 3/8	9	16.0
5	48		2 1/4	3/4	1	8	3 3/4	5 1/8	15 3/8	11 1/8	12 1/8	14 3/8	1 5/8	6 7/8	5 3/8	13 7/8	4 3/8	3 7/8	3	8 5/8	13 3/4	2 1/8	11 7/8	2 3/4	16 3/8	9	16.0

STANDARD SIGN  
W20-1A, B, C, D, E, F, G & H

WISCONSIN DEPT OF TRANSPORTATION

APPROVED *Matthew R. Rauch*  
For State Traffic Engineer

DATE 3/25/2020 PLATE NO. W20-1.11

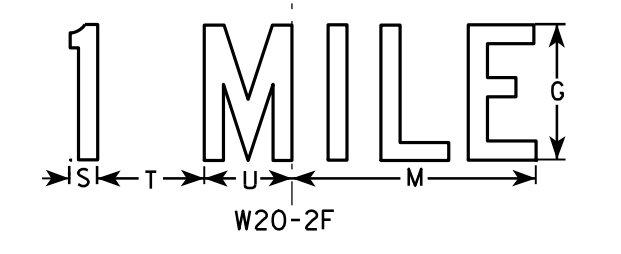
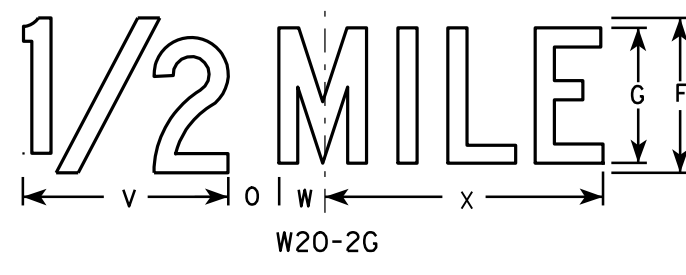
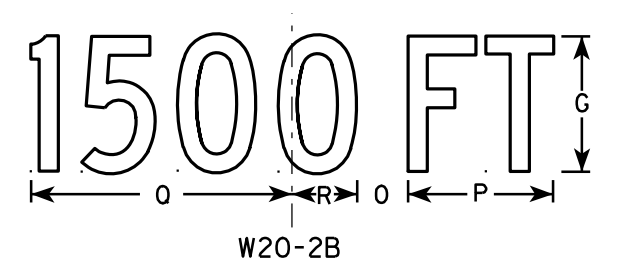
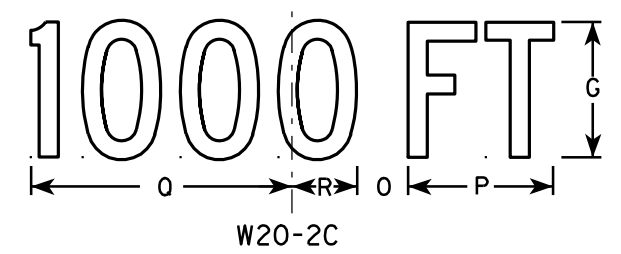
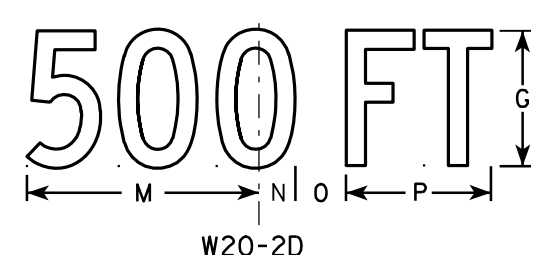
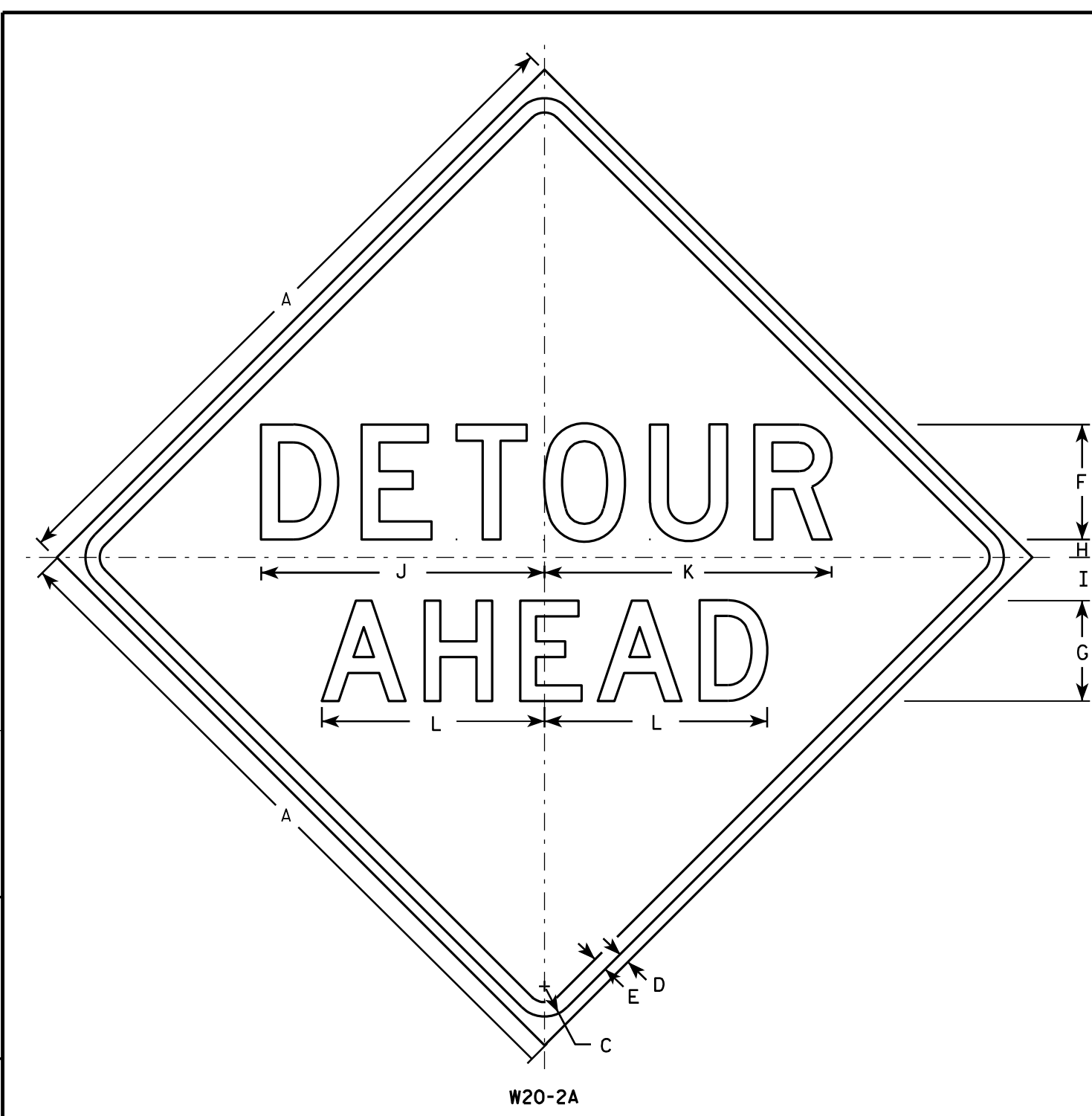

**NOTES**

1. Sign is Type II - Type F Reflective - reference WIS DOT Standard Specification for HIGHWAY and STRUCTURE CONSTRUCTION latest edition.
2. Color:  
Background - Orange  
Message - Black
3. Message Series - See note 5
4. Corners may be square or rounded when base material is plywood but borders shall be rounded as shown. When base material is metal, the corners and borders shall be rounded.
5. Line 1 is Series D.  
Line 2 is Series D for AHEAD and Series C for all other distances.

7

7

SIZE	A	B	C	D	E	F	G	H	I	J	K	L	M	N	O	P	Q	R	S	T	U	V	W	X	Y	Z	Area sq. ft.
1	36		1 5/8	5/8	3/4	6	5	1	2 1/4	14 3/4	15	11 5/8	9	1 3/8	1 7/8	5 5/8	10 1/8	2 1/2	1 1/8	4 1/2	3 1/2	8	1 3/4	10 3/4			9.0
2S	48		2 1/4	3/4	1	8	7	1 1/4	3	19 3/4	20	15 1/2	12	1 7/8	2 5/8	7 1/2	13 1/2	3 3/8	1 1/2	6	4 5/8	10 5/8	2 3/8	14 3/8			16.0
2M	48		2 1/4	3/4	1	8	7	1 1/4	3	19 3/4	20	15 1/2	12	1 7/8	2 5/8	7 1/2	13 1/2	3 3/8	1 1/2	6	4 5/8	10 5/8	2 3/8	14 3/8			16.0
3	48		2 1/4	3/4	1	8	7	1 1/4	3	19 3/4	20	15 1/2	12	1 7/8	2 5/8	7 1/2	13 1/2	3 3/8	1 1/2	6	4 5/8	10 5/8	2 3/8	14 3/8			16.0
4	48		2 1/4	3/4	1	8	7	1 1/4	3	19 3/4	20	15 1/2	12	1 7/8	2 5/8	7 1/2	13 1/2	3 3/8	1 1/2	6	4 5/8	10 5/8	2 3/8	14 3/8			16.0
5	48		2 1/4	3/4	1	8	7	1 1/4	3	19 3/4	20	15 1/2	12	1 7/8	2 5/8	7 1/2	13 1/2	3 3/8	1 1/2	6	4 5/8	10 5/8	2 3/8	14 3/8			16.0

STANDARD SIGN  
W20-2A, B, C, D, F & G

WISCONSIN DEPT OF TRANSPORTATION

APPROVED *Matthew R. Raub*  
for State Traffic Engineer

DATE 3/18/11 PLATE NO. W20-2.6

PROJECT NO: \_\_\_\_\_ HWY: \_\_\_\_\_ COUNTY: \_\_\_\_\_ SHEET NO: \_\_\_\_\_ E

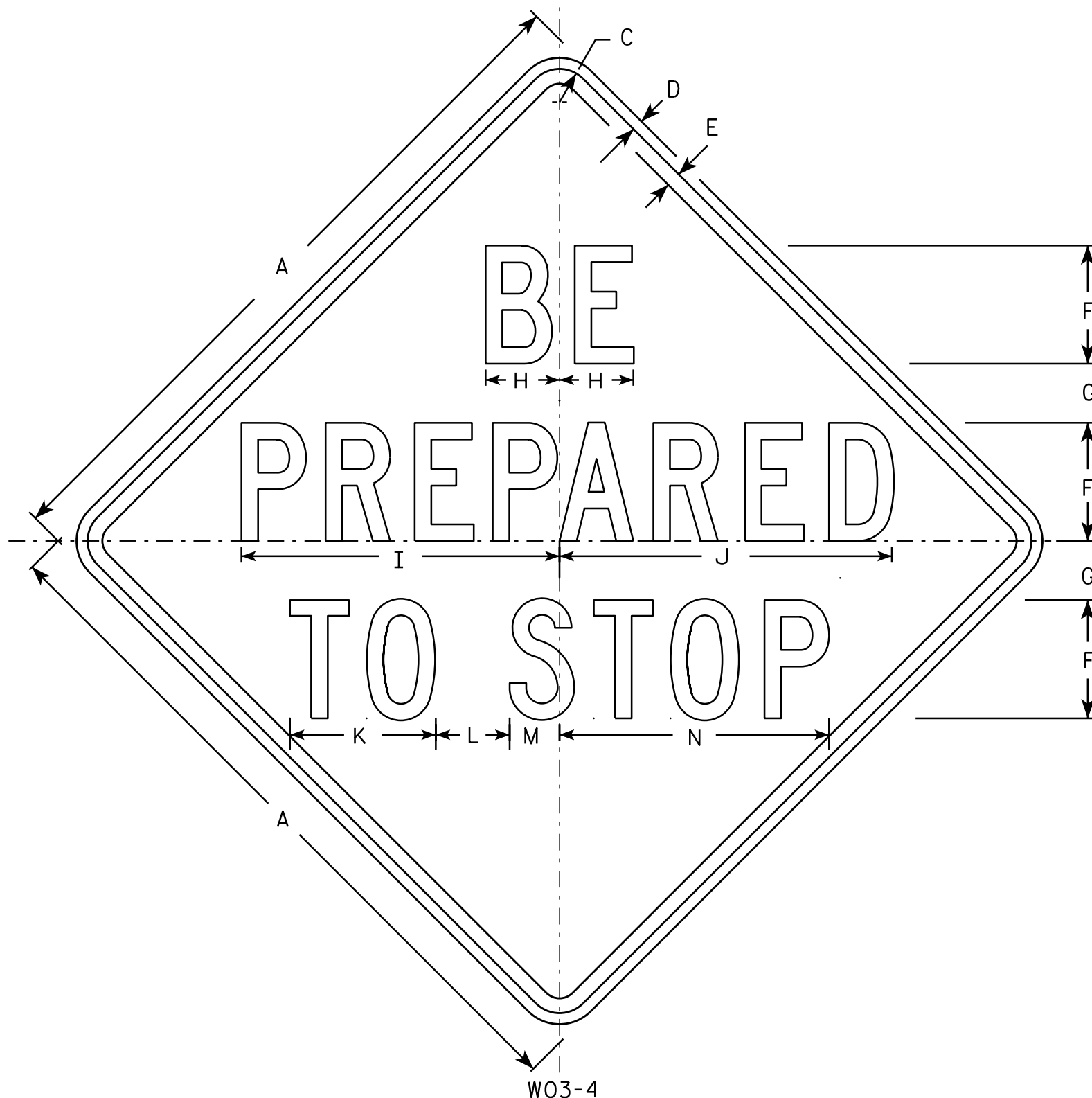

NOTES

1. Sign is Type II - Type F Reflective - reference WIS DOT Standard Specification for HIGHWAY and STRUCTURE CONSTRUCTION latest edition.
2. Color:  
Background - Orange  
Message - Black
3. Message Series - C
4. Corners may be square or rounded when base material is plywood but borders shall be rounded as shown. When base material is metal, the corners and borders shall be rounded.

7

7

W03-4

SIZE	A	B	C	D	E	F	G	H	I	J	K	L	M	N	O	P	Q	R	S	T	U	V	W	X	Y	Z	Area sq. ft.
1	36		1 3/8	1/2	5/8	6	2 1/2	3 3/4	15 7/8	16 7/8	7 3/8	4	2 3/8	13 3/4													9.0
2S	48		2 1/4	3/4	1	8	4	5	21 1/2	22 1/2	9 7/8	5	3 3/8	18 1/4													16.0
2M	48		2 1/4	3/4	1	8	4	5	21 1/2	22 1/2	9 7/8	5	3 3/8	18 1/4													16.0
3	48		2 1/4	3/4	1	8	4	5	21 1/2	22 1/2	9 7/8	5	3 3/8	18 1/4													16.0
4	48		2 1/4	3/4	1	8	4	5	21 1/2	22 1/2	9 7/8	5	3 3/8	18 1/4													16.0
5	48		2 1/4	3/4	1	8	4	5	21 1/2	22 1/2	9 7/8	5	3 3/8	18 1/4													16.0

STANDARD SIGN  
W03-4

WISCONSIN DEPT OF TRANSPORTATION

APPROVED *Matthew R. Rauch*  
for State Traffic Engineer

DATE 12/02/13 PLATE NO. W03-4.1

PROJECT NO: \_\_\_\_\_ HWY: \_\_\_\_\_ COUNTY: \_\_\_\_\_ SHEET NO: **E**



NOTES

1. Sign is Type II - Type F Reflective
2. Color:  
Background - Orange  
Message - Black
3. Message Series - D
4. Corners may be square or rounded when base material is plywood but borders shall be rounded as shown. When base material is metal, the corners and borders shall be rounded.

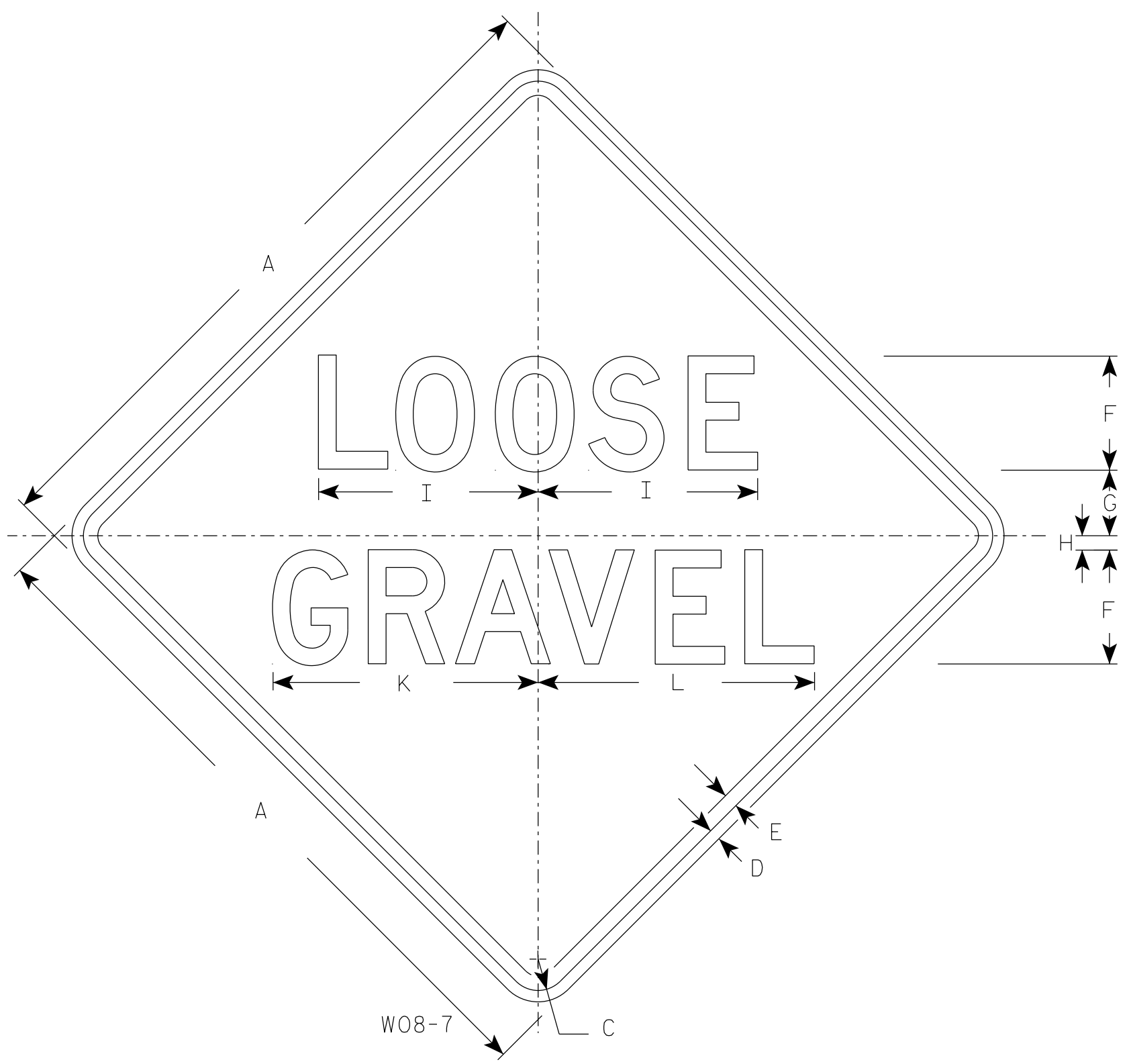

W08-7 C

SIZE	A	B	C	D	E	F	G	H	I	J	K	L	M	N	O	P	Q	R	S	T	U	V	W	X	Y	Z	Area sq. ft.
1	36		1 5/8	5/8	3/4	6	4 1/8	3/4	11 5/8		14	14 1/2															9.0
2S	48		2 1/4	3/4	1	8	5 1/2	1	15 1/2		18 5/8	19 3/8															16.0
2M	48		2 1/4	3/4	1	8	5 1/2	1	15 1/2		18 5/8	19 3/8															16.0
3	48		2 1/4	3/4	1	8	5 1/2	1	15 1/2		18 5/8	19 3/8															16.0
4	48		2 1/4	3/4	1	8	5 1/2	1	15 1/2		18 5/8	19 3/8															16.0
5	48		2 1/4	3/4	1	8	5 1/2	1	15 1/2		18 5/8	19 3/8															16.0

STANDARD SIGN  
W08-7

WISCONSIN DEPT OF TRANSPORTATION

APPROVED *Matthew R. Rauch*  
for State Traffic Engineer

DATE 4/16/2020 PLATE NO. W08-7.8

PROJECT NO: \_\_\_\_\_ HWY: \_\_\_\_\_ COUNTY: \_\_\_\_\_ SHEET NO: **E**

7

7

**EARTHWORK - CTH C (STA. 157+25 - 165+50)**

STATION	AREA (SF)		INCREMENTAL VOL (CY) (UNADJUSTED)		CUMULATIVE VOL (CY)		
	CUT	FILL	CUT NOTE 1	FILL NOTE 3	CUT	EXPANDED FILL	MASS ORDINATE NOTE 8
					1.00 NOTE 1	1.30	
157+25.00	0.00	0.00	0	0	0	0	0
157+50.00	31.54	0.00	15	0	15	0	15
157+75.00	37.89	0.01	32	0	47	0	47
158+00.00	37.25	0.34	35	0	82	0	82
158+10.00	29.61	67.31	12	13	94	17	77
158+25.00	31.12	5.12	17	20	111	43	68
158+50.00	32.45	1.31	29	3	140	47	93
158+75.00	35.63	0.10	32	1	172	48	124
159+00.00	39.58	0.00	35	0	207	48	159
159+25.00	41.81	0.00	38	0	245	48	197
159+50.00	46.60	0.00	41	0	286	48	238
159+75.00	50.12	0.00	45	0	331	48	283
160+00.00	48.60	0.00	46	0	377	48	329
160+25.00	46.80	0.00	44	0	421	48	373
160+50.00	44.19	0.00	42	0	463	48	415
160+75.00	45.05	0.00	41	0	504	48	456
161+00.00	52.39	0.00	45	0	549	48	501
161+25.00	87.77	0.00	65	0	614	48	566
161+50.00	75.21	0.00	75	0	689	48	641
161+75.00	51.82	0.00	59	0	748	48	700
162+00.00	46.85	0.00	46	0	794	48	746
162+25.00	41.58	0.00	41	0	835	48	787
162+50.00	36.22	0.00	36	0	871	48	823
162+75.00	31.72	0.00	31	0	902	48	854
163+00.00	31.90	0.00	29	0	931	48	883
163+25.00	34.60	0.00	31	0	962	48	914
163+50.00	29.86	0.00	30	0	992	48	944
163+75.00	34.62	0.00	30	0	1,022	48	974
164+00.00	36.53	0.00	33	0	1,055	48	1,007
164+25.00	38.12	0.00	35	0	1,090	48	1,042
164+50.00	38.12	0.00	35	0	1,125	48	1,077
164+75.00	38.31	0.00	35	0	1,160	48	1,112
165+00.00	37.20	0.00	35	0	1,195	48	1,147
165+25.00	36.38	0.00	34	0	1,229	48	1,181
165+50.00	31.65	0.00	31	0	1,260	48	1,212

**EARTHWORK - CTH F (STA. 328+00 - 329+50)**

STATION	AREA (SF)		INCREMENTAL VOL (CY) (UNADJUSTED)		CUMULATIVE VOL (CY)		
	CUT	FILL	CUT NOTE 1	FILL NOTE 3	CUT	EXPANDED FILL	MASS ORDINATE NOTE 8
					1.00 NOTE 1	1.30	
328+00.00	25.90	0.00	0	0	0	0	0
328+50.00	21.43	0.00	44	0	44	0	44
328+96.00	25.69	0.00	40	0	84	0	84
329+32.00	7.51	3.12	22	2	106	3	103
329+50.00	1.28	4.85	3	3	109	7	103

NOTES:	
1 - CUT	CUT INCLUDES SALVAGED/UNUSABLE PAVEMENT MATERIAL
3 - FILL	DOES NOT INCLUDE UNUSABLE PAVEMENT EXC VOLUME
8 - MASS ORDINATE	CUT - FILL * FILL FACTOR

**EARTHWORK - CTH C (STA. 188+25 - 202+78)**

STATION	AREA (SF)		INCREMENTAL VOL (CY) (UNADJUSTED)		CUMULATIVE VOL (CY)		
	CUT	FILL	CUT NOTE 1	FILL	CUT	EXPANDED FILL	MASS ORDINATE
					1.00 NOTE 1	1.30	NOTE 8
188+25.41	0.00	0.00	0	0	0	0	0
188+50.00	36.09	0.00	16	0	16	0	16
188+75.00	38.24	0.00	34	0	50	0	50
189+00.00	40.83	0.00	37	0	87	0	87
189+25.00	43.02	0.00	39	0	126	0	126
189+50.00	43.49	0.04	40	0	166	0	166
189+75.00	28.89	0.13	34	0	200	0	200
190+00.41	23.49	2.15	25	1	225	1	224
190+25.41	19.88	4.27	20	3	245	5	240
190+50.41	17.22	5.21	17	4	262	10	252
190+75.41	16.15	3.72	15	4	277	16	261
191+00.41	16.45	1.37	15	2	292	18	274
191+26.58	20.69	6.22	18	4	310	23	287
191+50.00	16.37	13.36	16	8	326	34	292
191+75.00	19.09	10.75	16	11	342	48	294
192+00.00	33.67	1.12	24	5	366	55	311
192+25.00	34.24	1.10	31	1	397	56	341
192+50.00	50.09	0.00	39	1	436	57	379
192+75.00	62.41	0.00	52	0	488	57	431
193+00.00	56.88	0.00	55	0	543	57	486
193+25.00	57.08	0.07	53	0	596	57	539
193+50.00	49.76	2.34	49	1	645	59	587
193+75.00	57.01	0.12	49	1	694	60	634
194+00.00	60.47	0.00	54	0	748	60	688
194+25.41	58.65	0.05	56	0	804	60	744
194+50.00	46.29	0.00	48	0	852	60	792
194+75.00	42.51	0.00	41	0	893	60	833
195+00.00	40.30	0.00	38	0	931	60	871
195+25.00	43.26	0.00	39	0	970	60	910
195+50.00	40.60	0.00	39	0	1,009	60	949
195+75.00	45.62	0.00	40	0	1,049	60	989
196+00.00	50.47	0.00	44	0	1,093	60	1,033
196+25.00	55.79	0.00	49	0	1,142	60	1,082
196+50.00	59.61	0.00	53	0	1,195	60	1,135
196+75.00	62.94	0.00	57	0	1,252	60	1,192

**EARTHWORK - CTH C (STA. 188+25 - 202+78)**

STATION	AREA (SF)		INCREMENTAL VOL (CY) (UNADJUSTED)		CUMULATIVE VOL (CY)		
	CUT	FILL	CUT NOTE 1	FILL	CUT	EXPANDED FILL	MASS ORDINATE
					1.00 NOTE 1	1.30	NOTE 8
197+00.00	78.58	0.00	66	0	1,318	60	1,258
197+25.00	87.24	0.00	77	0	1,395	60	1,335
197+50.00	86.61	0.00	80	0	1,475	60	1,415
197+75.00	79.38	0.00	77	0	1,552	60	1,492
198+00.00	79.32	0.00	73	0	1,625	60	1,565
198+25.00	73.05	0.55	71	0	1,696	60	1,636
198+38.00	70.18	0.52	34	0	1,730	60	1,670
198+50.00	66.20	0.08	30	0	1,760	60	1,700
198+75.00	59.58	3.69	58	2	1,818	62	1,756
198+92.46	87.10	2.93	47	2	1,865	65	1,800
199+00.00	97.85	0.00	26	0	1,891	65	1,826
199+08.39	106.15	0.08	32	0	1,923	65	1,858
199+25.00	85.65	0.07	59	0	1,982	65	1,917
199+30.78	82.57	0.96	18	0	2,000	65	1,935
199+50.00	55.03	3.69	49	2	2,049	68	1,981
199+75.00	49.81	4.51	49	4	2,098	73	2,025
200+00.00	53.90	0.00	48	2	2,146	75	2,071
200+25.00	44.76	2.55	46	1	2,192	77	2,115
200+50.00	44.28	1.87	41	2	2,233	79	2,154
200+75.00	54.57	0.00	46	1	2,279	81	2,198
200+81.05	55.15	0.00	12	0	2,291	81	2,210
201+00.00	50.21	0.00	37	0	2,328	81	2,247
201+25.00	48.30	0.01	46	0	2,374	81	2,293
201+50.00	45.01	0.00	43	0	2,417	81	2,336
201+75.00	41.82	0.00	40	0	2,457	81	2,376
202+00.00	38.15	0.04	37	0	2,494	81	2,413
202+25.00	39.40	0.12	36	0	2,530	81	2,449
202+50.00	40.18	0.79	37	0	2,567	81	2,486
202+75.00	55.28	0.00	44	0	2,611	81	2,530

NOTES:	
1 - CUT	CUT INCLUDES SALVAGED/UNUSABLE PAVEMENT MATERIAL
3 - FILL	DOES NOT INCLUDE UNUSABLE PAVEMENT EXC VOLUME
8 - MASS ORDINATE	CUT - FILL * FILL FACTOR

**EARTHWORK - CTH C GUARDRAIL (STA. 120+25 LT - 121+75 LT)**

STATION	AREA (SF)		Incremental Vol (CY) (Unadjusted)		Cumulative Vol (CY)		Mass Ordinate
	Cut	Fill	Cut	Fill	Expanded		Note 8
					Cut 1.00	Fill 1.30	
120+25.00	7.3	0.0					
120+50.00	8.4	0.0	7	0	7	0	7
120+75.00	8.8	0.5	8	0	15	0	15
121+01.38	8.3	4.9	8	3	24	4	20
121+26.30	9.2	4.0	8	4	32	9	23
121+51.30	7.3	4.1	8	4	39	14	25
121+75.00	7.0	7.6	6	5	46	20	25

**EARTHWORK - CTH C GUARDRAIL (STA. 207+25 RT - 209+50 RT)**

STATION	AREA (SF)		Incremental Vol (CY) (Unadjusted)		Cumulative Vol (CY)		Mass Ordinate
	Cut	Fill	Cut	Fill	Expanded		Note 8
					Cut 1.00	Fill 1.30	
207+25.41	8.3	0.0					
207+50.41	9.3	0.0	8	0	8	0	8
208+00.41	10.0	2.9	18	2	26	2	24
208+08.59	9.9	4.1	3	1	29	3	26
208+33.51	9.9	0.3	9	2	38	6	32
208+50.41	10.3	0.0	6	1	44	7	37
208+58.51	10.1	0.0	3	0	48	7	40
209+00.41	5.5	0.4	12	0	60	8	52
209+50.41	5.0	20.0	10	13	69	24	45

**EARTHWORK - CTH C GUARDRAIL (STA. 123+50 RT - 124+52 RT)**

STATION	AREA (SF)		Incremental Vol (CY) (Unadjusted)		Cumulative Vol (CY)		Mass Ordinate
	Cut	Fill	Cut	Fill	Expanded		Note 8
					Cut 1.00	Fill 1.30	
123+50.00	5.3	26.1					
123+83.39	8.8	0.8	9	17	9	22	-13
124+01.00	9.5	0.2	6	0	15	22	-7
124+08.10	9.4	0.1	2	0	17	22	-5
124+26.70	9.4	1.4	6	1	24	23	1
124+33.02	9.7	2.0	2	0	26	23	3
124+51.62	10.6	0.0	7	1	33	24	9

**EARTHWORK - CTH C GUARDRAIL (STA. 211+50 RT - 212+72 RT)**

STATION	AREA (SF)		Incremental Vol (CY) (Unadjusted)		Cumulative Vol (CY)		Mass Ordinate
	Cut	Fill	Cut	Fill	Expanded		Note 8
					Cut 1.00	Fill 1.30	
211+50.41	3.1	3.0					
211+70.11	3.3	2.4	2	2	2	3	0
211+95.11	6.8	1.5	5	2	7	5	2
212+00.41	8.5	0.9	2	0	9	5	3
212+20.01	7.9	1.6	6	1	14	6	8
212+21.31	8.7	1.5	0	0	15	6	8
212+46.31	9.0	0.0	8	1	22	8	15
212+50.41	7.8	0.0	1	0	24	8	16
212+71.83	7.9	0.0	6	0	30	8	22

NOTES:	
8 - MASS ORDINATE	CUT - FILL * FILL FACTOR

**EARTHWORK - CTH C GUARDRAIL (STA. 235+84 LT - 237+86 LT)**

STATION	AREA (SF)		Incremental Vol (CY) (Unadjusted)		Cumulative Vol (CY)		Mass Ordinate
	Cut	Fill	Cut	Fill	Cut 1.00	Expanded Fill 1.30	
235+83.90	2.0	0.0					
236+00.00	4.1	69.9	2	21	2	27	-25
236+43.57	3.2	74.2	5	77	7	128	-121
236+50.41	3.2	68.0	1	18	8	151	-143
236+68.79	3.4	0.0	2	32	10	193	-183
236+93.61	3.2	0.0	3	21	13	220	-207
237+00.00	3.8	0.0	1	0	14	220	-206
237+50.00	3.2	0.0	6	0	20	220	-200
237+86.20	2.8	0.0	4	0	24	220	-196

**EARTHWORK - CTH C GUARDRAIL (STA. 242+69 RT - 244+00 RT)**

STATION	AREA (SF)		Incremental Vol (CY) (Unadjusted)		Cumulative Vol (CY)		Mass Ordinate
	Cut	Fill	Cut	Fill	Cut 1.00	Expanded Fill 1.30	
242+68.78	3.6	0.0					
242+70.68	3.8	0.0	0	0	0	0	0
242+93.92	3.2	1.4	3	1	3	1	2
242+95.46	3.9	1.5	0	0	3	1	3
243+00.00	4.1	2.0	1	0	4	1	3
243+19.81	3.4	6.5	3	3	7	5	2
243+20.58	3.4	6.3	0	0	7	5	2
243+50.00	4.0	4.3	4	6	11	13	-2
244+00.00	3.0	3.0	6	7	18	22	-4

NOTES:	
8 - MASS ORDINATE	CUT - FILL * FILL FACTOR

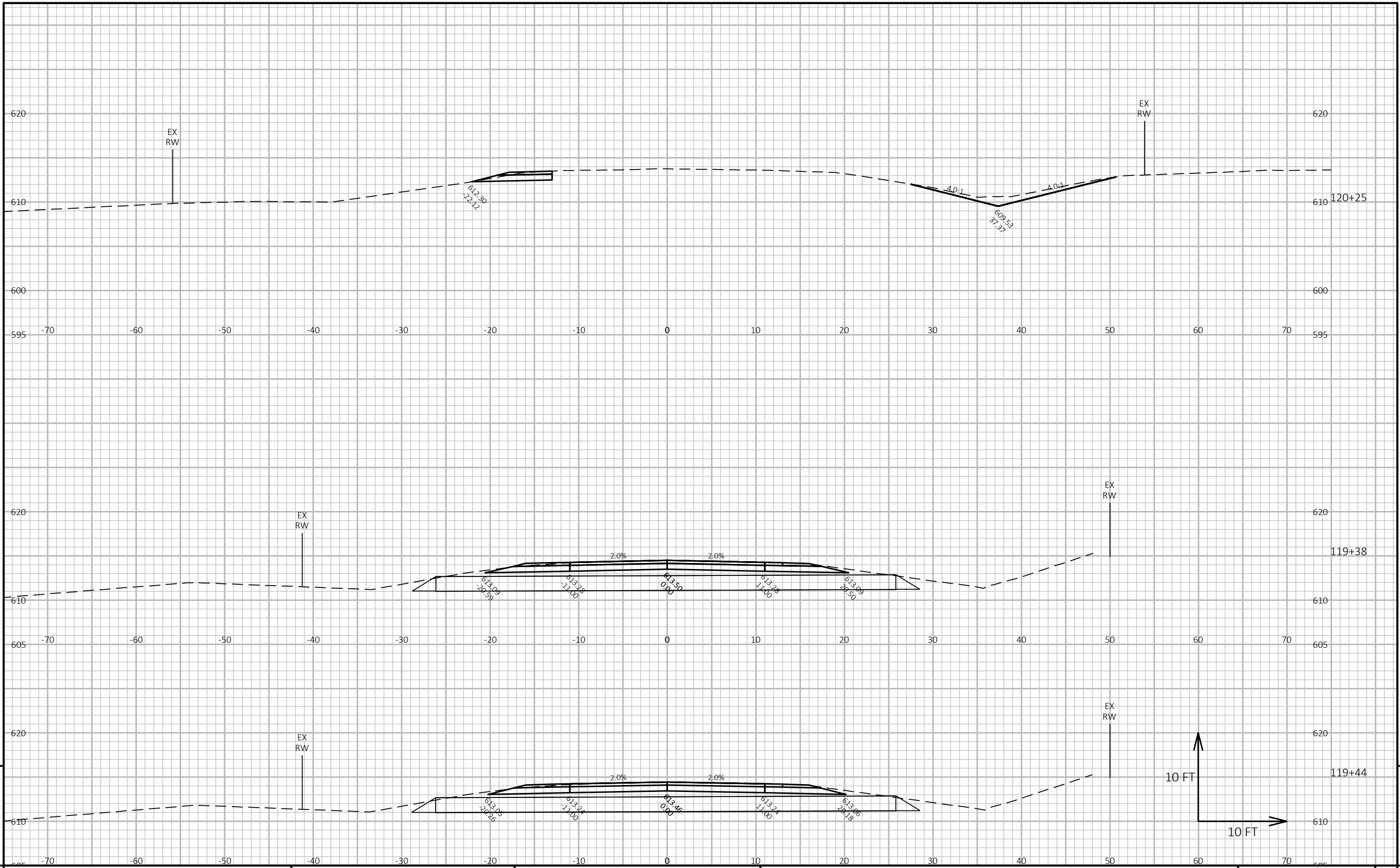

PROJECT NO: 4390-07-71	HWY: CTH C	COUNTY: KEWAUNEE	CROSS SECTIONS: WEST GUARDRAIL	SHEET	E
------------------------	------------	------------------	--------------------------------	-------	---

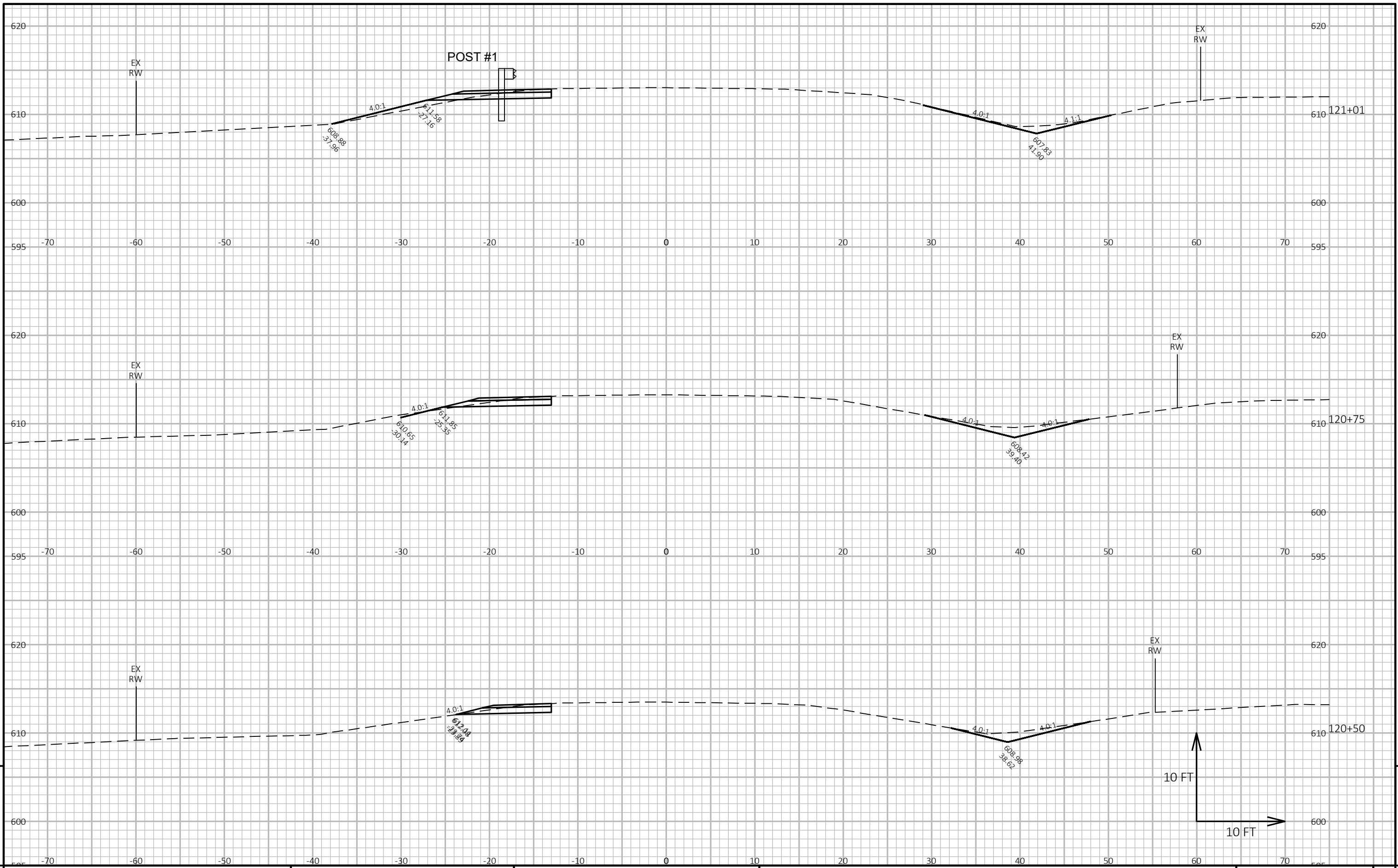

PROJECT NO: 4390-07-71	HWY: CTH C	COUNTY: KEWAUNEE	CROSS SECTIONS: WEST GUARDRAIL	SHEET	E
------------------------	------------	------------------	--------------------------------	-------	---

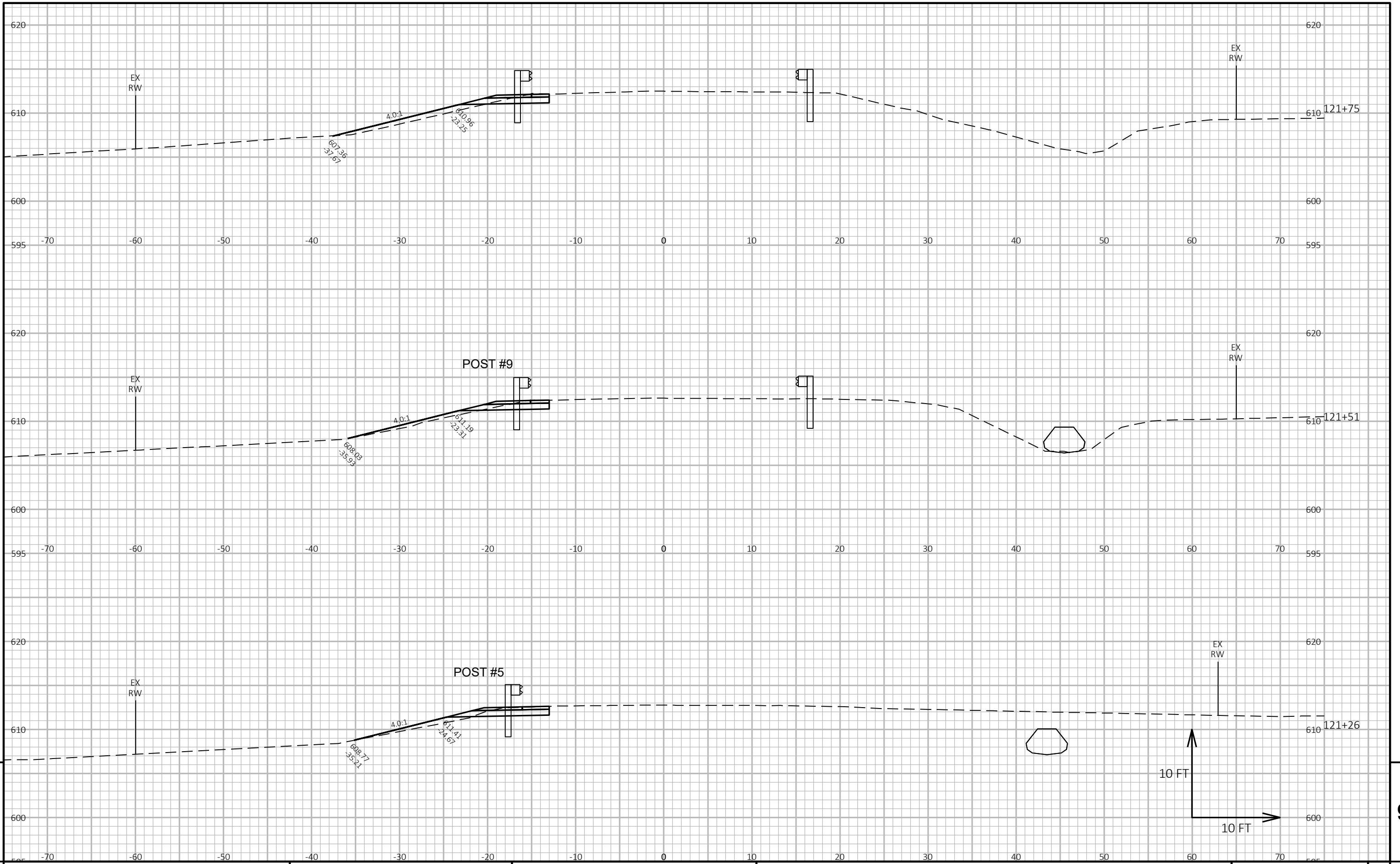

PROJECT NO: 4390-07-71      HWY: CTH C      COUNTY: KEWAUNEE      CROSS SECTIONS: WEST GUARDRAIL      SHEET      E



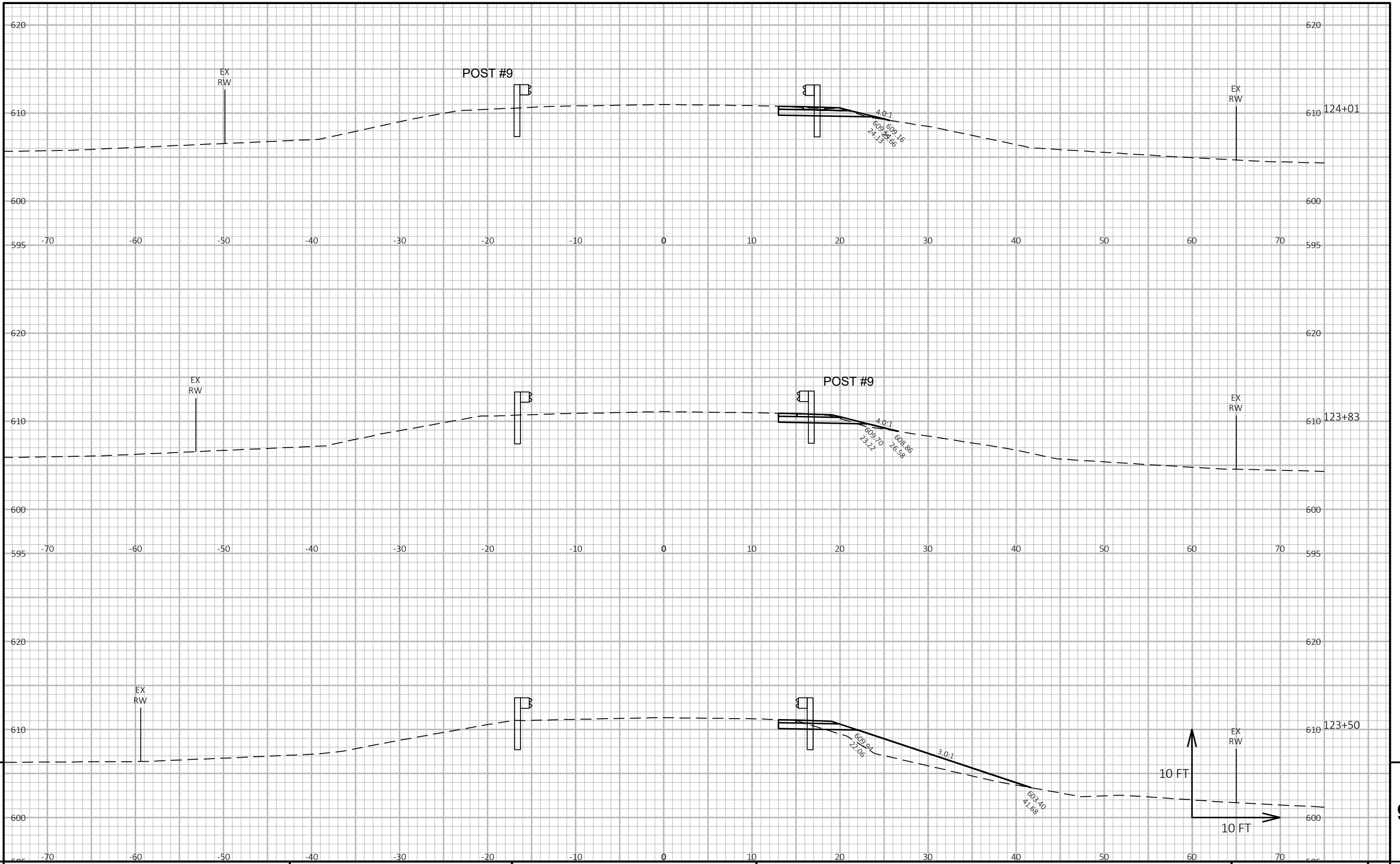

PROJECT NO: 4390-07-71

HWY: CTH C

COUNTY: KEWAUNEE

CROSS SECTIONS: WEST GUARDRAIL

SHEET

E

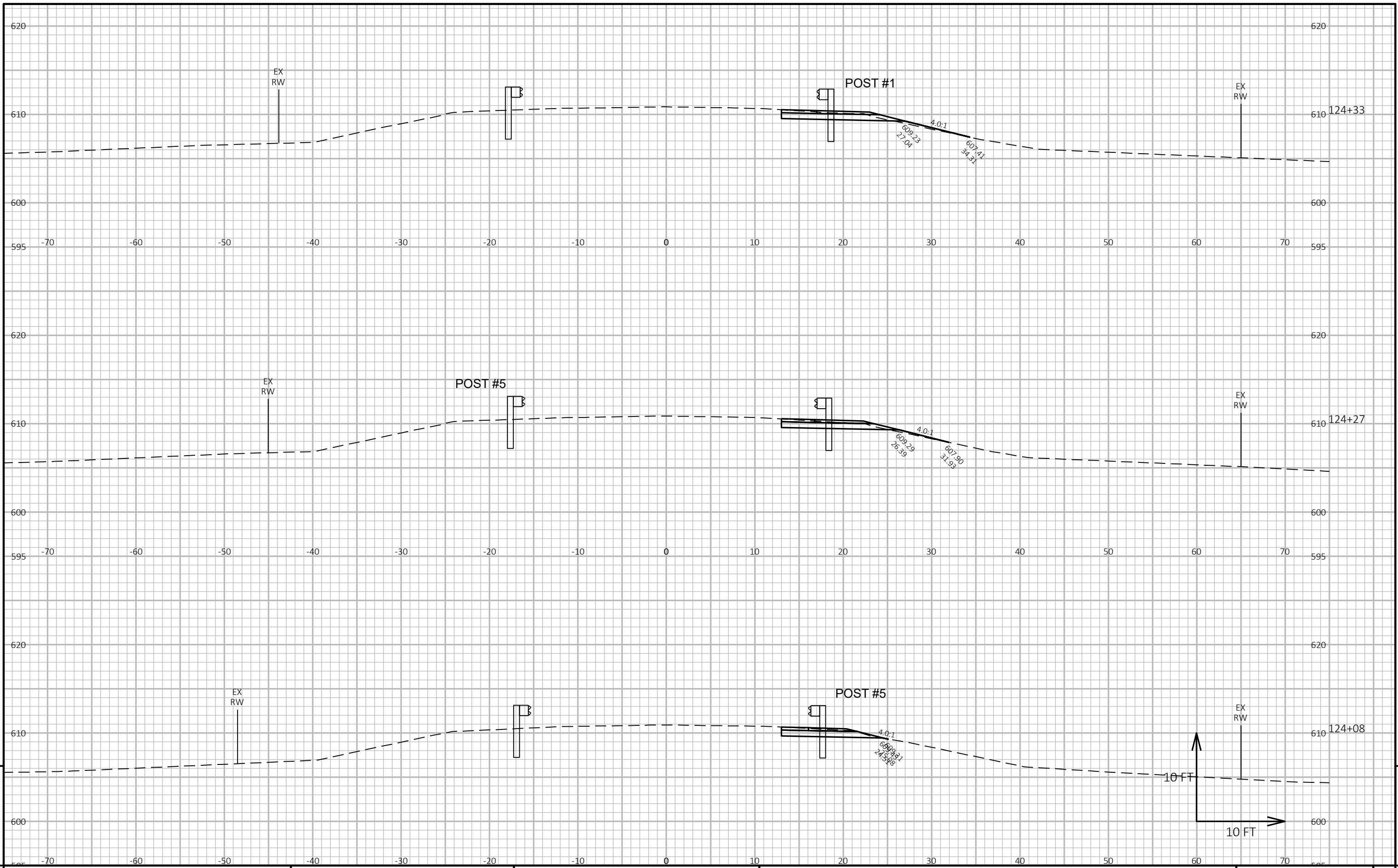

PROJECT NO: 4390-07-71	HWY: CTH C	COUNTY: KEWAUNEE	CROSS SECTIONS: WEST GUARDRAIL	SHEET	E
------------------------	------------	------------------	--------------------------------	-------	---

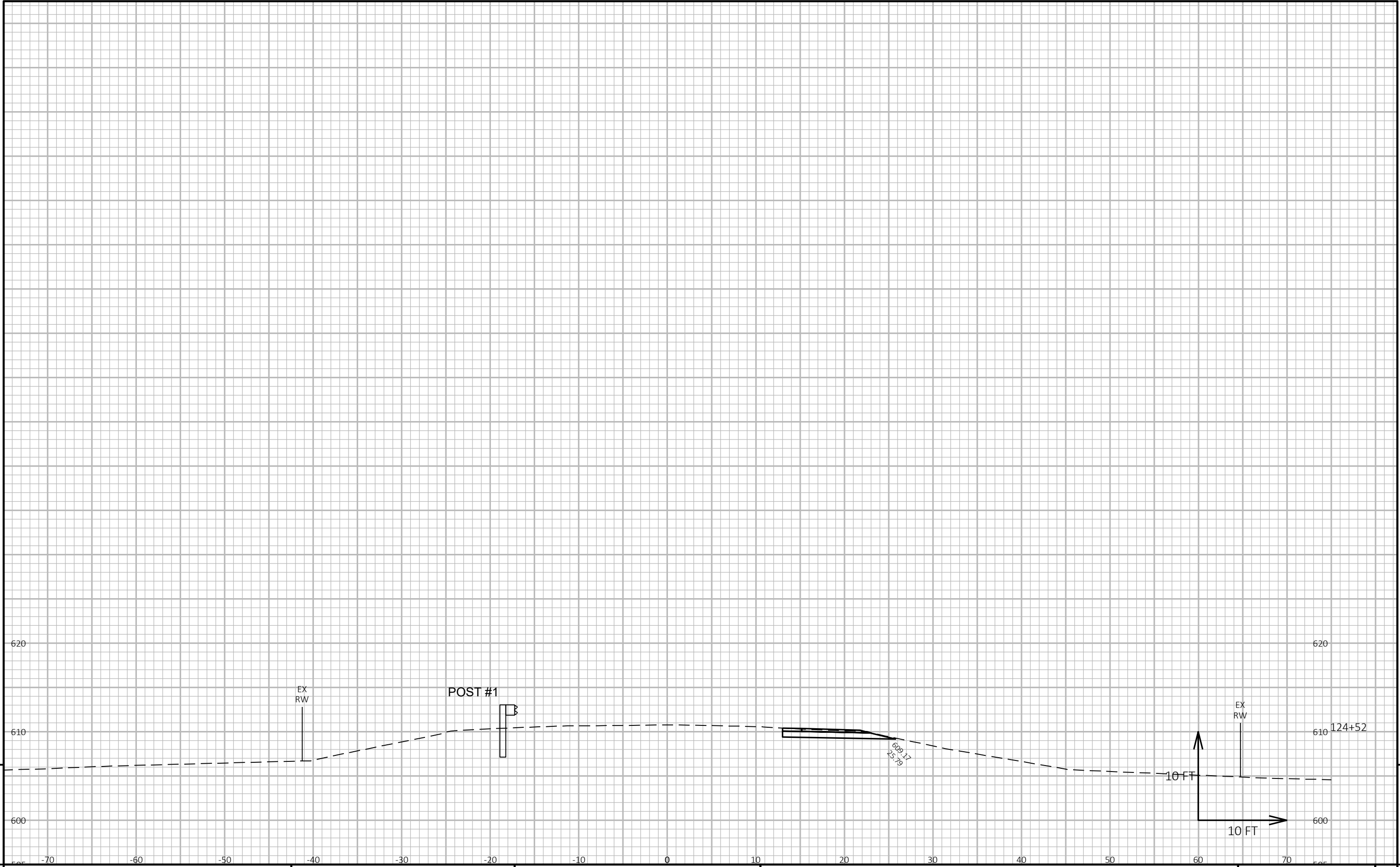

9

9

PROJECT NO: 4390-07-71	HWY: CTH C	COUNTY: KEWAUNEE	CROSS SECTIONS: WEST GUARDRAIL	SHEET	E
------------------------	------------	------------------	--------------------------------	-------	---

FILE NAME : I:\45\450511 KEWAUNEE CTH C ROADWAY\C3D\SHEETSPLAN\090201-XS.DWG PLOT DATE : 1/9/2024 12:14 PM PLOT BY : GARNICA, BRANDON PLOT NAME : PLOT SCALE : 1 IN:10 FT HORZ. / 1 IN:10 FT VERT. WISDOT/CADD SHEET 49

LAYOUT NAME - 090206-xs



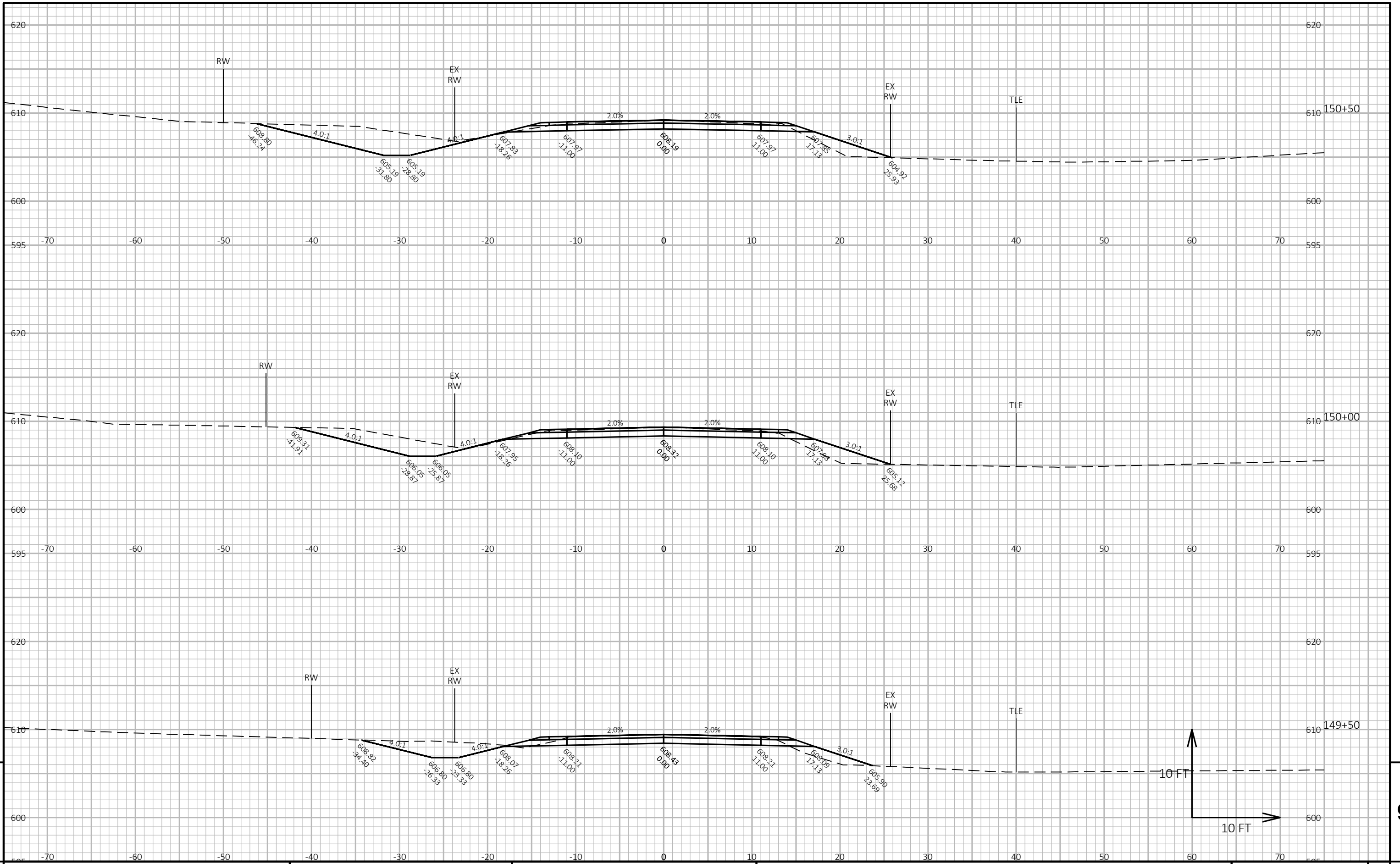

9

9

PROJECT NO: 4390-07-71      HWY: CTH C      COUNTY: KEWAUNEE      CROSS SECTIONS: CULVERTS      SHEET      E

FILE NAME: I:\45\450511 KEWAUNEE CTH C ROADWAY\C3D\SHEETSPLAN\090201-XS.DWG      PLOT DATE: 1/9/2024 12:15 PM      PLOT BY: GARNICA, BRANDON      PLOT NAME:      PLOT SCALE: 1 IN:10 FT HORZ. / 1 IN:10 FT VERT.      WISDOT/CADD SHEET 49

LAYOUT NAME - 090208-xs

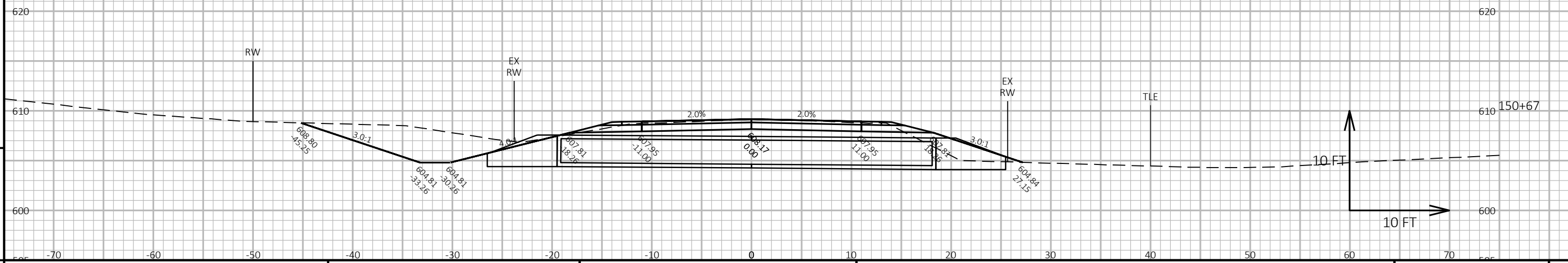
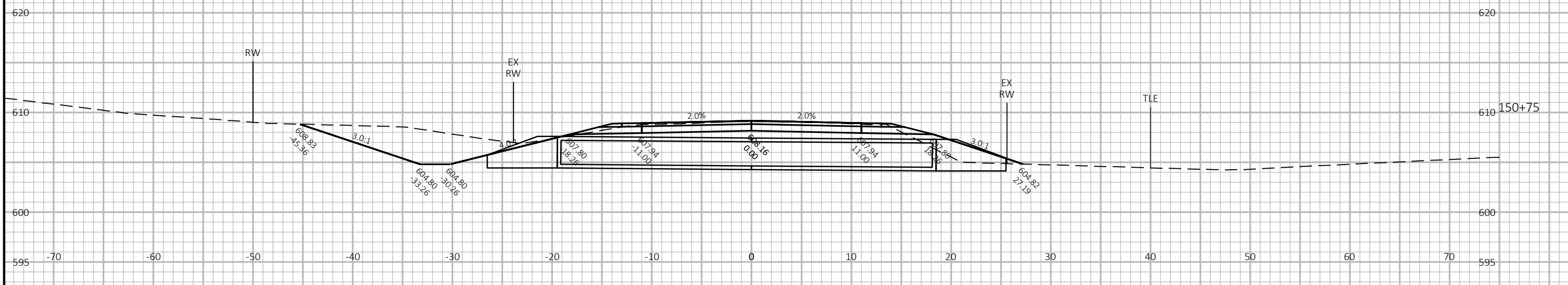
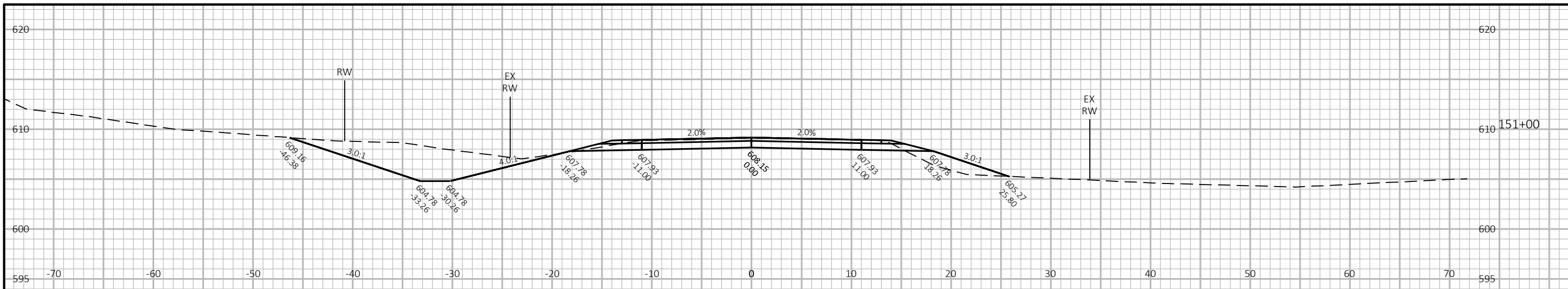

PROJECT NO: 4390-07-71      HWY: CTH C      COUNTY: KEWAUNEE      CROSS SECTIONS: CULVERTS      SHEET 9

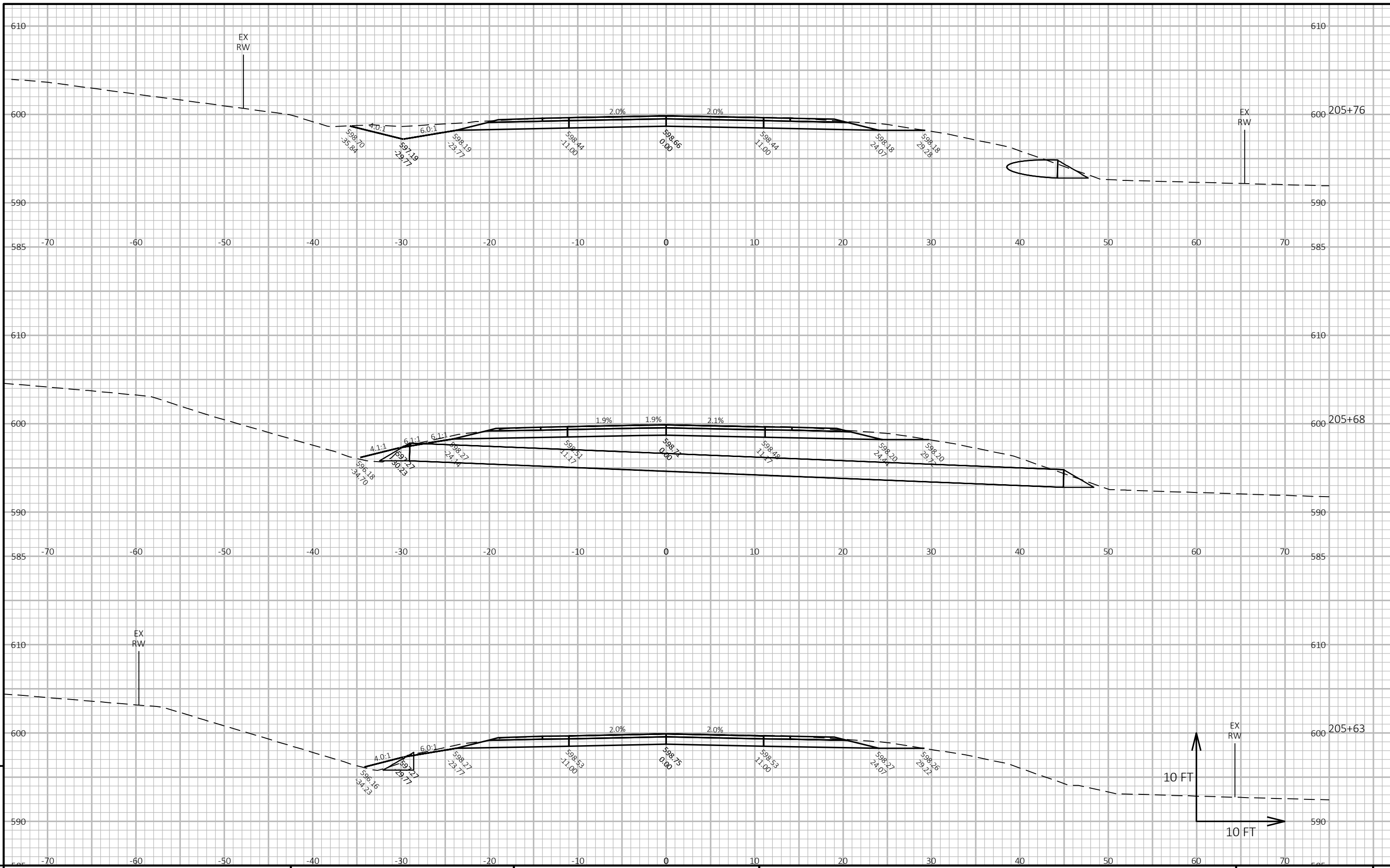

PROJECT NO: 4390-07-71

HWY: CTH C

COUNTY: KEWAUNEE

CROSS SECTIONS: CULVERTS

SHEET

E

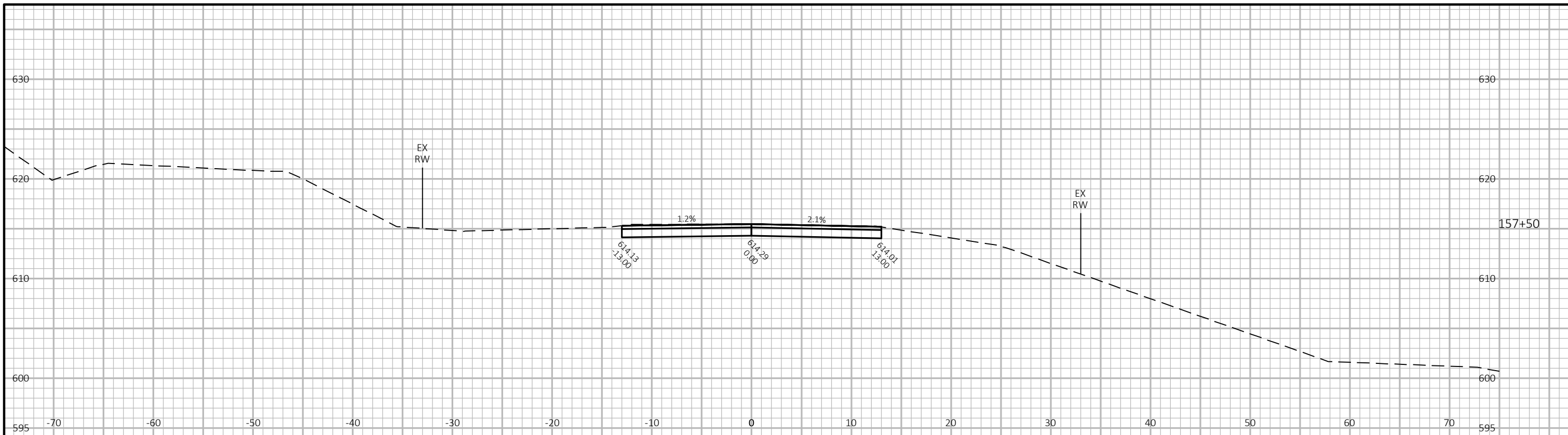

9

9

PROJECT NO: 4390-07-71      HWY: CTH C      COUNTY: KEWAUNEE      CROSS SECTIONS: SUPER SECTION      SHEET E

FILE NAME: I:\45\450511 KEWAUNEE CTH C ROADWAY\C3D\SHEETSPLAN\090201-XS.DWG      PLOT DATE: 1/9/2024 12:15 PM      PLOT BY: GARNICA, BRANDON      PLOT NAME:      PLOT SCALE: 1 IN:10 FT HORZ. / 1 IN:10 FT VERT.      WISDOT/CADD SHEET 49

LAYOUT NAME - 090269-xs



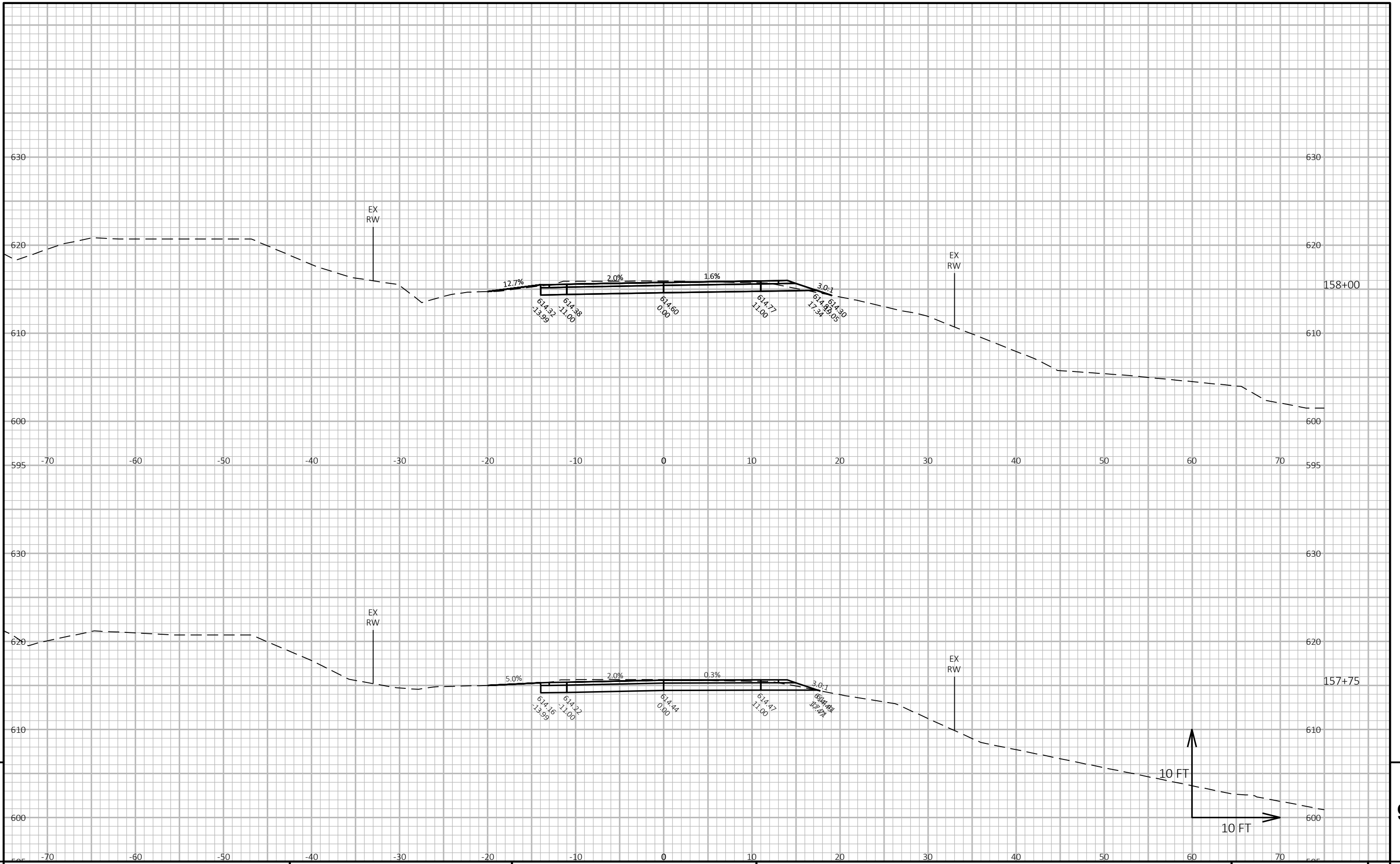

9

9

PROJECT NO: 4390-07-71	HWY: CTH C	COUNTY: KEWAUNEE	CROSS SECTIONS: SUPER SECTION	SHEET	E
------------------------	------------	------------------	-------------------------------	-------	---

FILE NAME : I:\45\450511 KEWAUNEE CTH C ROADWAY\C3D\SHEETSPLAN\090201-XS.DWG PLOT DATE : 1/9/2024 12:15 PM PLOT BY : GARNICA, BRANDON PLOT NAME : PLOT SCALE : 1 IN:10 FT HORZ. / 1 IN:10 FT VERT. WISDOT/CADD SHEET 49

LAYOUT NAME - 090270-xs

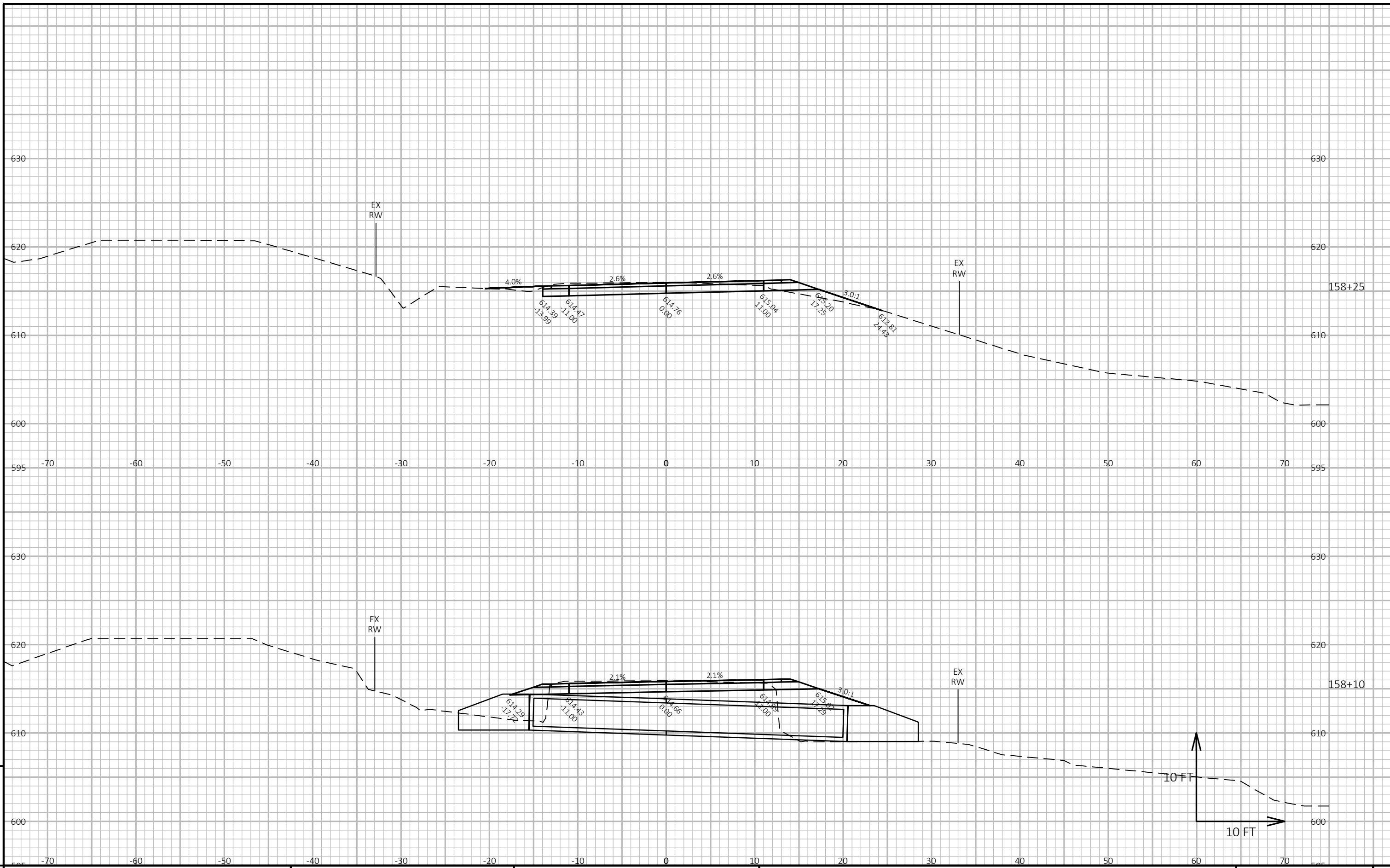

9

9

PROJECT NO: 4390-07-71      HWY: CTH C      COUNTY: KEWAUNEE      CROSS SECTIONS: SUPER SECTION      SHEET E

FILE NAME: I:\45\450511 KEWAUNEE CTH C ROADWAY\C3D\SHEETSPLAN\090201-XS.DWG      PLOT DATE: 1/9/2024 12:15 PM      PLOT BY: GARNICA, BRANDON      PLOT NAME:      PLOT SCALE: 1 IN:10 FT HORZ. / 1 IN:10 FT VERT.      WISDOT/CADD SHEET 49

LAYOUT NAME - 090271-xs



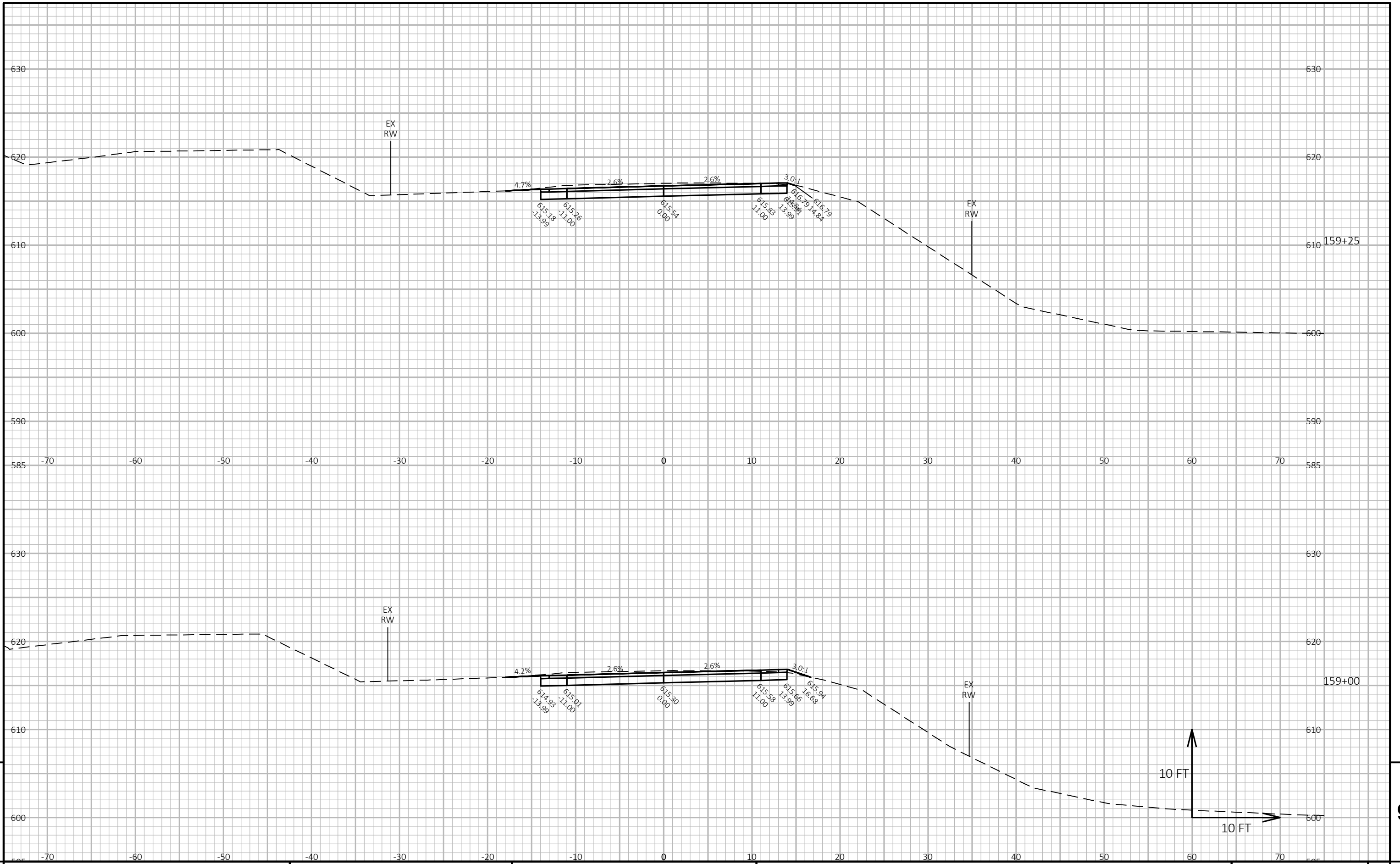

9

9

PROJECT NO: 4390-07-71	HWY: CTH C	COUNTY: KEWAUNEE	CROSS SECTIONS: SUPER SECTION	SHEET	E
------------------------	------------	------------------	-------------------------------	-------	---

FILE NAME : I:\45\450511 KEWAUNEE CTH C ROADWAY\C3D\SHEETSPLAN\090201-XS.DWG  
 LAYOUT NAME - 090273-xs  
 PLOT DATE : 1/9/2024 12:15 PM  
 PLOT BY : GARNICA, BRANDON  
 PLOT NAME :  
 PLOT SCALE : 1 IN:10 FT HORZ. / 1 IN:10 FT VERT.  
 WISDOT/CADD SHEET 49

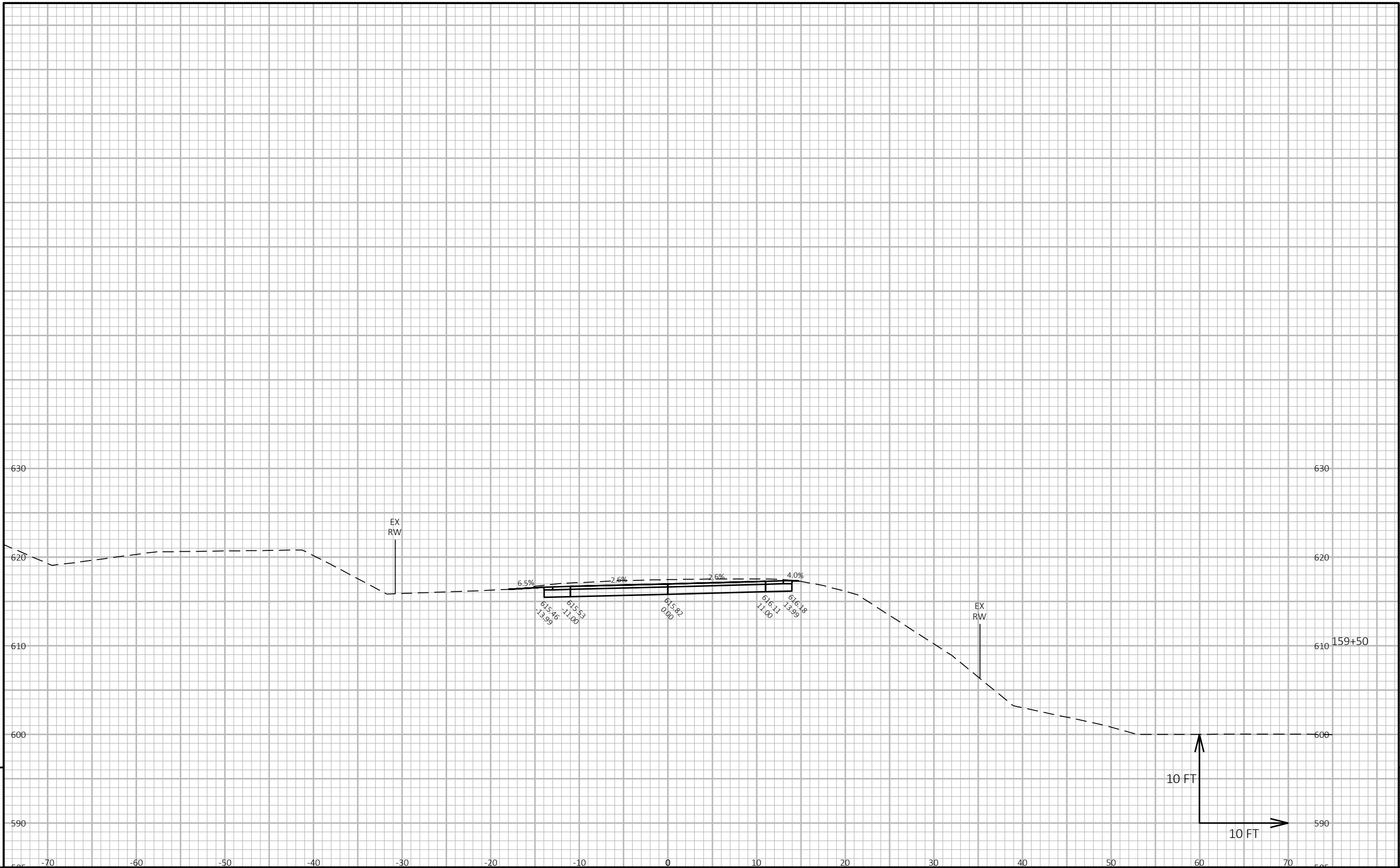

9

9

PROJECT NO: 4390-07-71	HWY: CTH C	COUNTY: KEWAUNEE	CROSS SECTIONS: SUPER SECTION	SHEET	E
------------------------	------------	------------------	-------------------------------	-------	---

FILE NAME : I:\45\450511 KEWAUNEE CTH C ROADWAY\C3D\SHEETSPLAN\090201-XS.DWG  
LAYOUT NAME - 090274-xs

PLOT DATE : 1/9/2024 12:15 PM

PLOT BY : GARNICA, BRANDON

PLOT NAME :

PLOT SCALE : 1 IN:10 FT HORZ. / 1 IN:10 FT VERT.

WISDOT/CADD SHEET 49

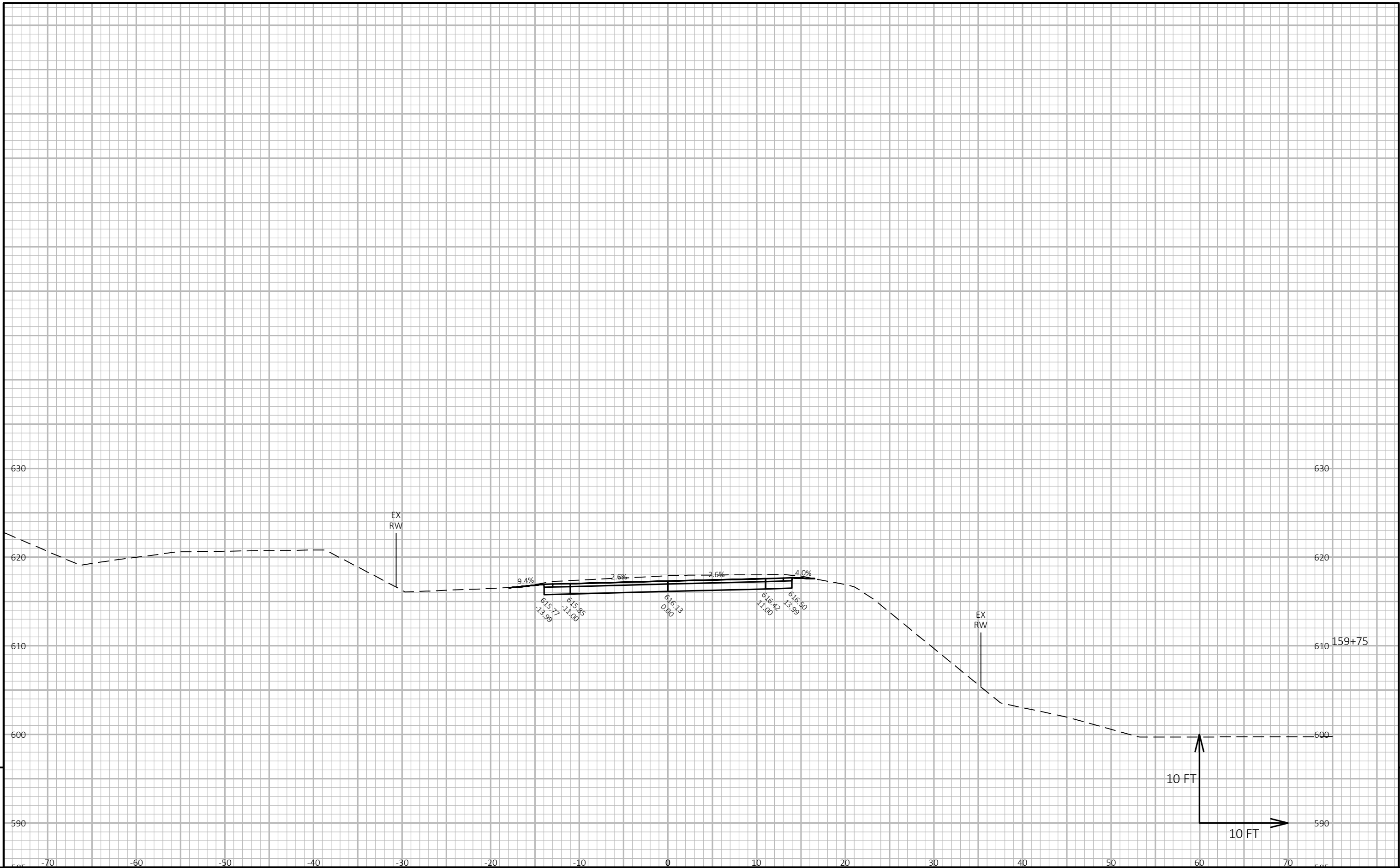

9

9

PROJECT NO: 4390-07-71	HWY: CTH C	COUNTY: KEWAUNEE	CROSS SECTIONS: SUPER SECTION	SHEET E
------------------------	------------	------------------	-------------------------------	---------

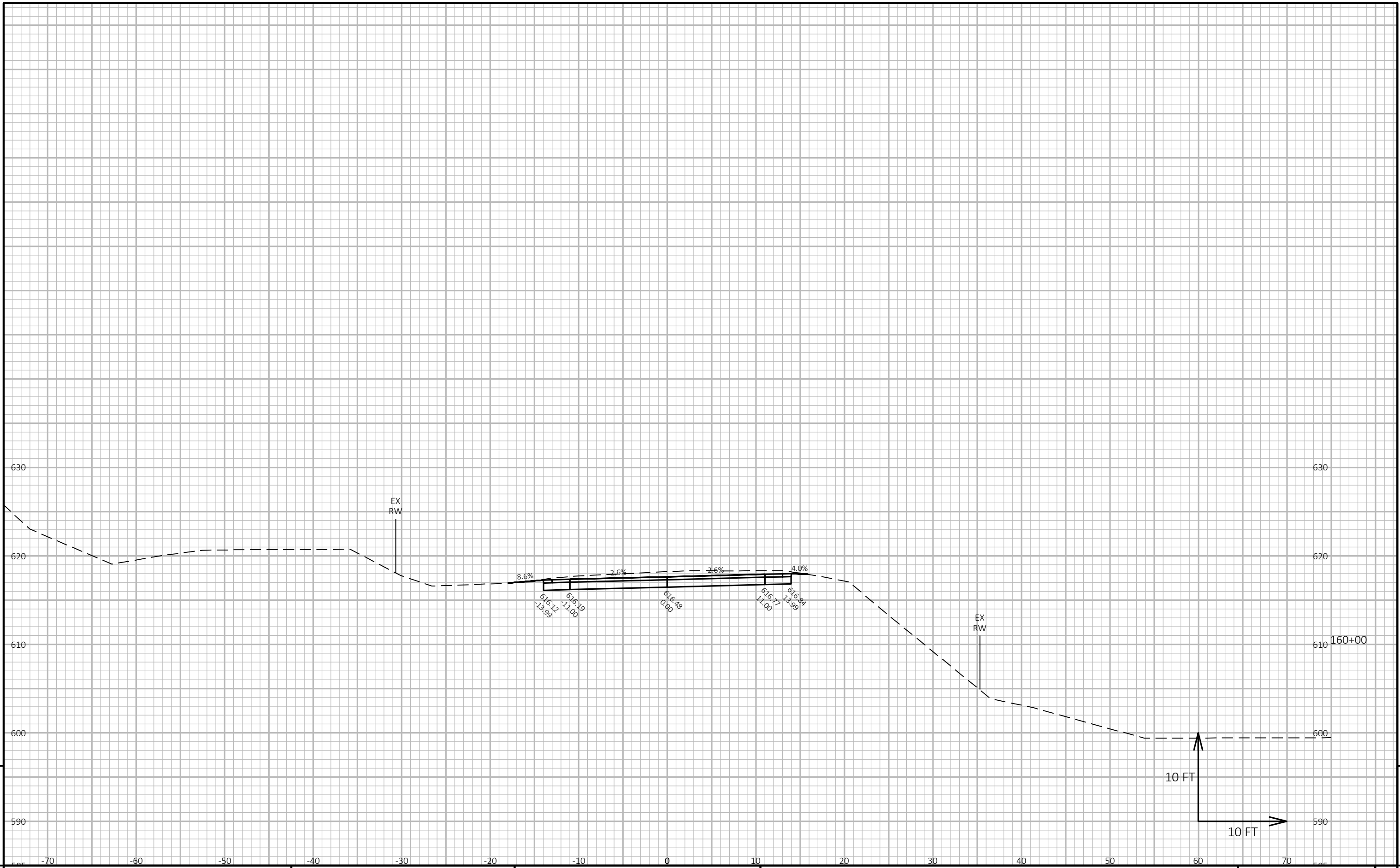

9

9

PROJECT NO: 4390-07-71	HWY: CTH C	COUNTY: KEWAUNEE	CROSS SECTIONS: SUPER SECTION	SHEET	E
------------------------	------------	------------------	-------------------------------	-------	---

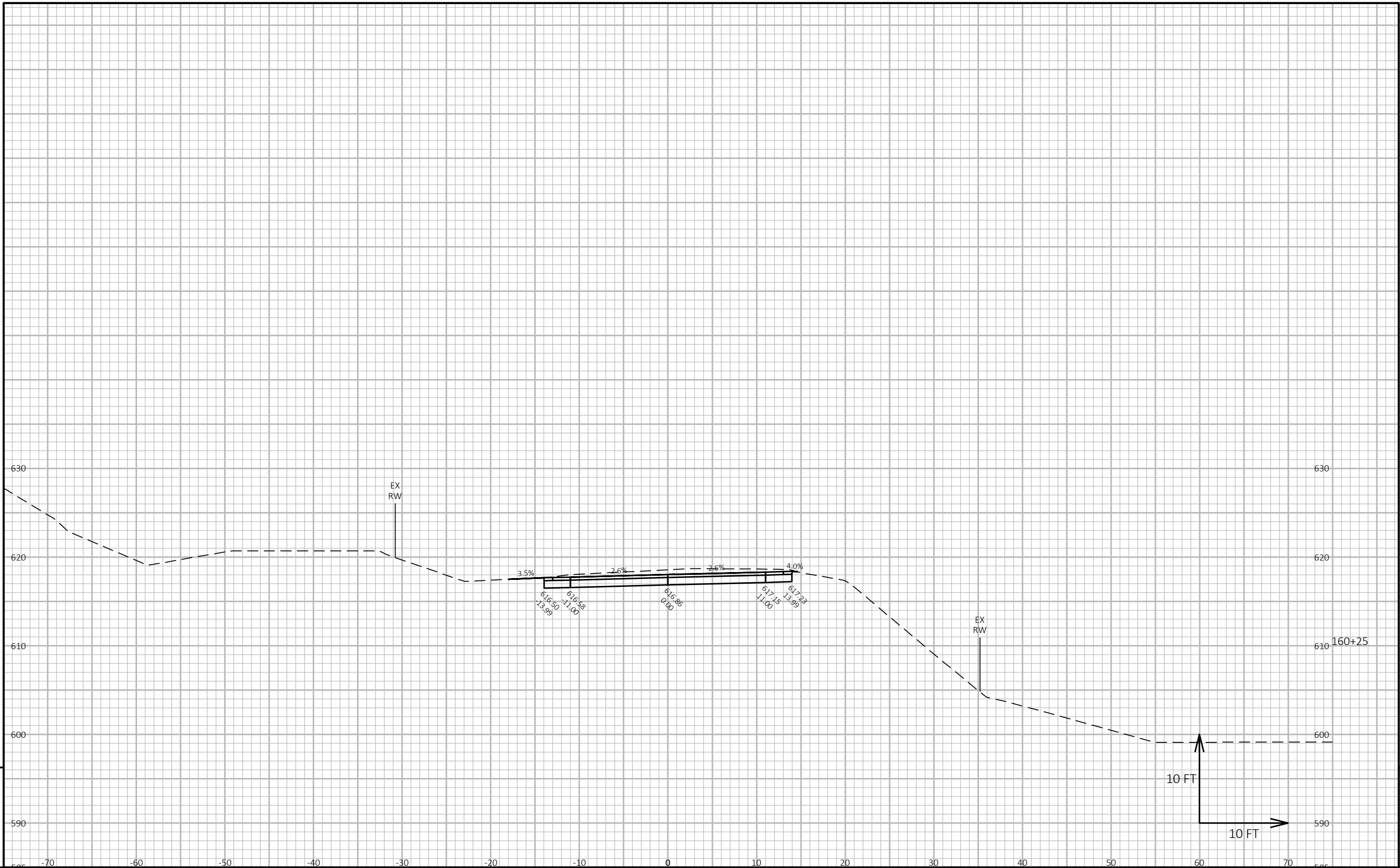

9

9

PROJECT NO: 4390-07-71	HWY: CTH C	COUNTY: KEWAUNEE	CROSS SECTIONS: SUPER SECTION	SHEET	E
------------------------	------------	------------------	-------------------------------	-------	---

FILE NAME : I:\45\450511 KEWAUNEE CTH C ROADWAY\C3D\SHEETSPLAN\090201-XS.DWG  
LAYOUT NAME - 090277-xs

PLOT DATE : 1/9/2024 12:15 PM

PLOT BY : GARNICA, BRANDON

PLOT NAME :

PLOT SCALE : 1 IN:10 FT HORZ. / 1 IN:10 FT VERT.

WISDOT/CADDs SHEET 49



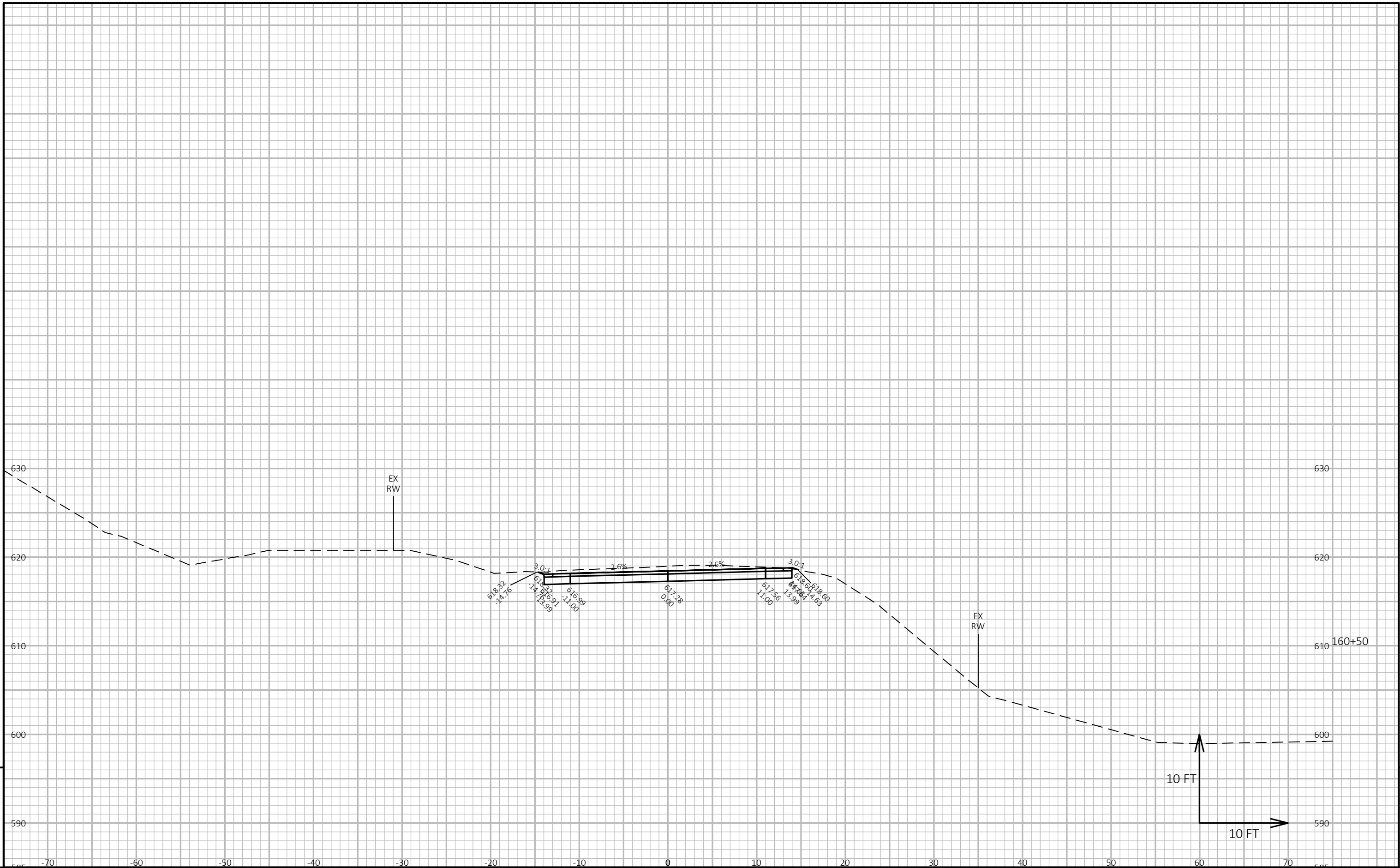

9

9

PROJECT NO: 4390-07-71

HWY: CTH C

COUNTY: KEWAUNEE

CROSS SECTIONS: SUPER SECTION

SHEET

E

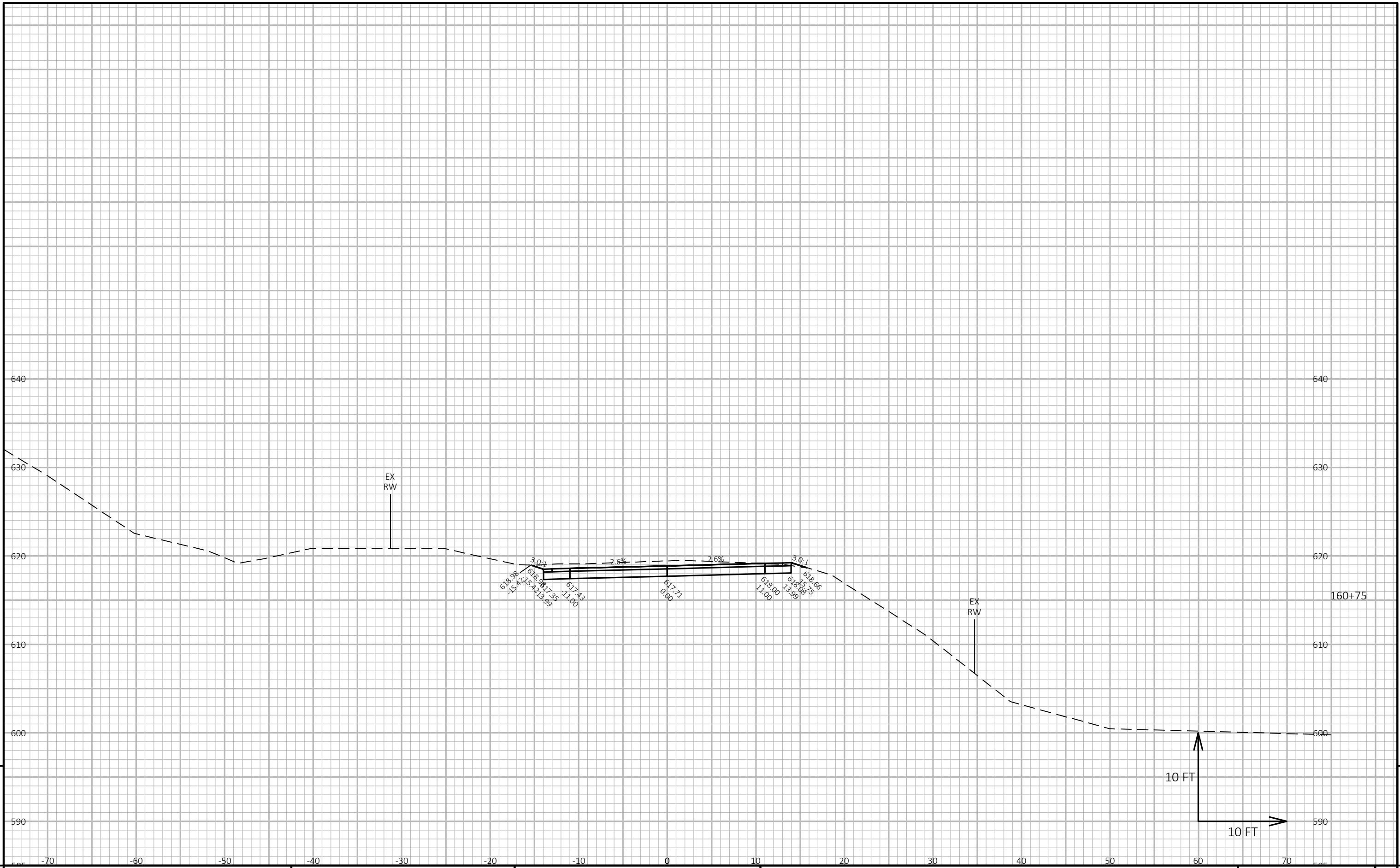

9

9

PROJECT NO: 4390-07-71	HWY: CTH C	COUNTY: KEWAUNEE	CROSS SECTIONS: SUPER SECTION	SHEET	E
------------------------	------------	------------------	-------------------------------	-------	---

FILE NAME : I:\45\450511 KEWAUNEE CTH C ROADWAY\C3D\SHEETSPLAN\090201-XS.DWG  
LAYOUT NAME - 090279-xs

PLOT DATE : 1/9/2024 12:16 PM

PLOT BY : GARNICA, BRANDON

PLOT NAME :

PLOT SCALE : 1 IN:10 FT HORZ. / 1 IN:10 FT VERT.

WISDOT/CADDs SHEET 49

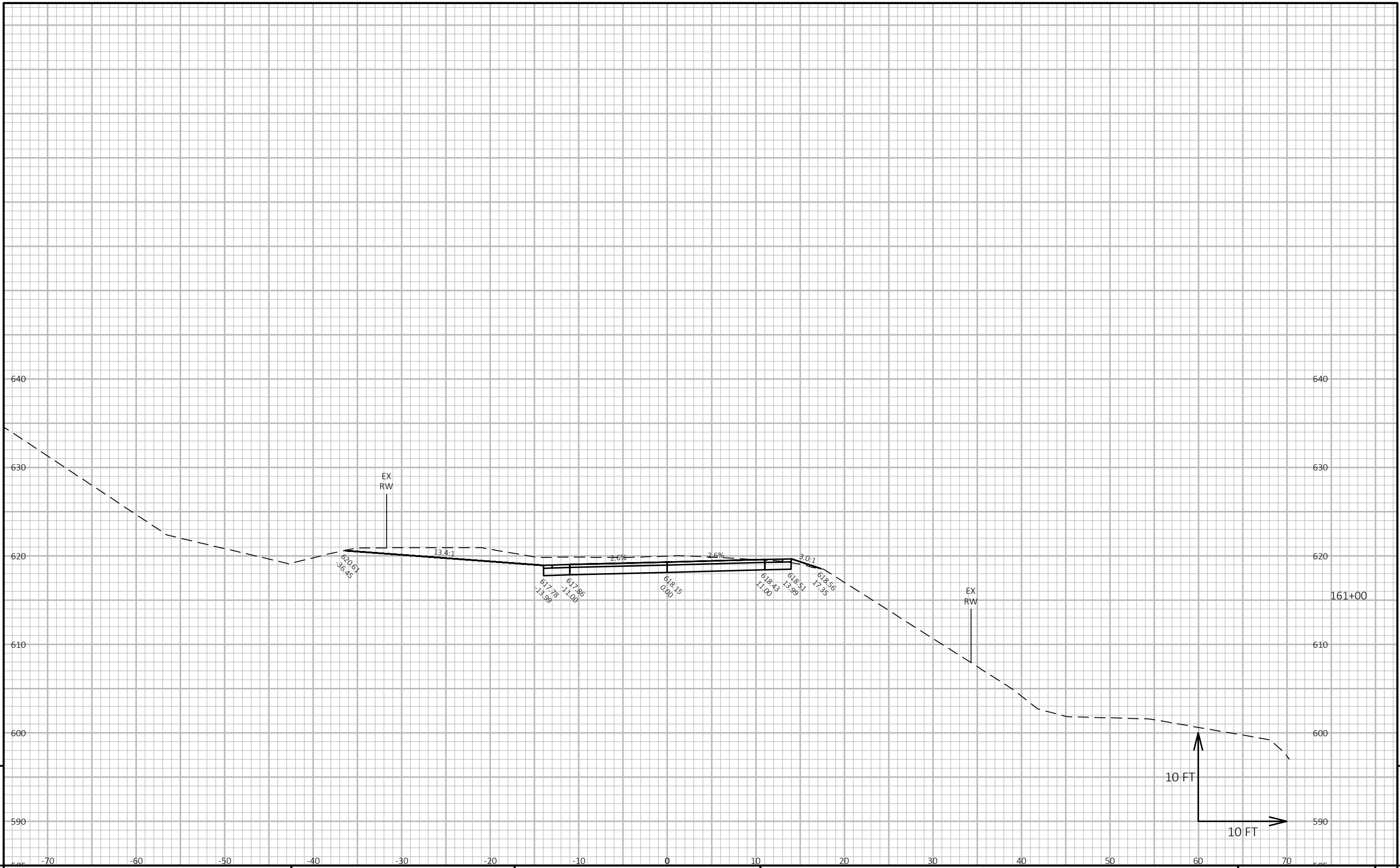

9

9

PROJECT NO: 4390-07-71	HWY: CTH C	COUNTY: KEWAUNEE	CROSS SECTIONS: SUPER SECTION	SHEET	E
------------------------	------------	------------------	-------------------------------	-------	---

FILE NAME : I:\45\450511 KEWAUNEE CTH C ROADWAY\C3D\SHEETSPLAN\090201-XS.DWG  
 LAYOUT NAME - 090280-xs  
 PLOT DATE : 1/9/2024 12:16 PM  
 PLOT BY : GARNICA, BRANDON  
 PLOT NAME :  
 PLOT SCALE : 1 IN:10 FT HORZ. / 1 IN:10 FT VERT.  
 WISDOT/CADD SHEET 49



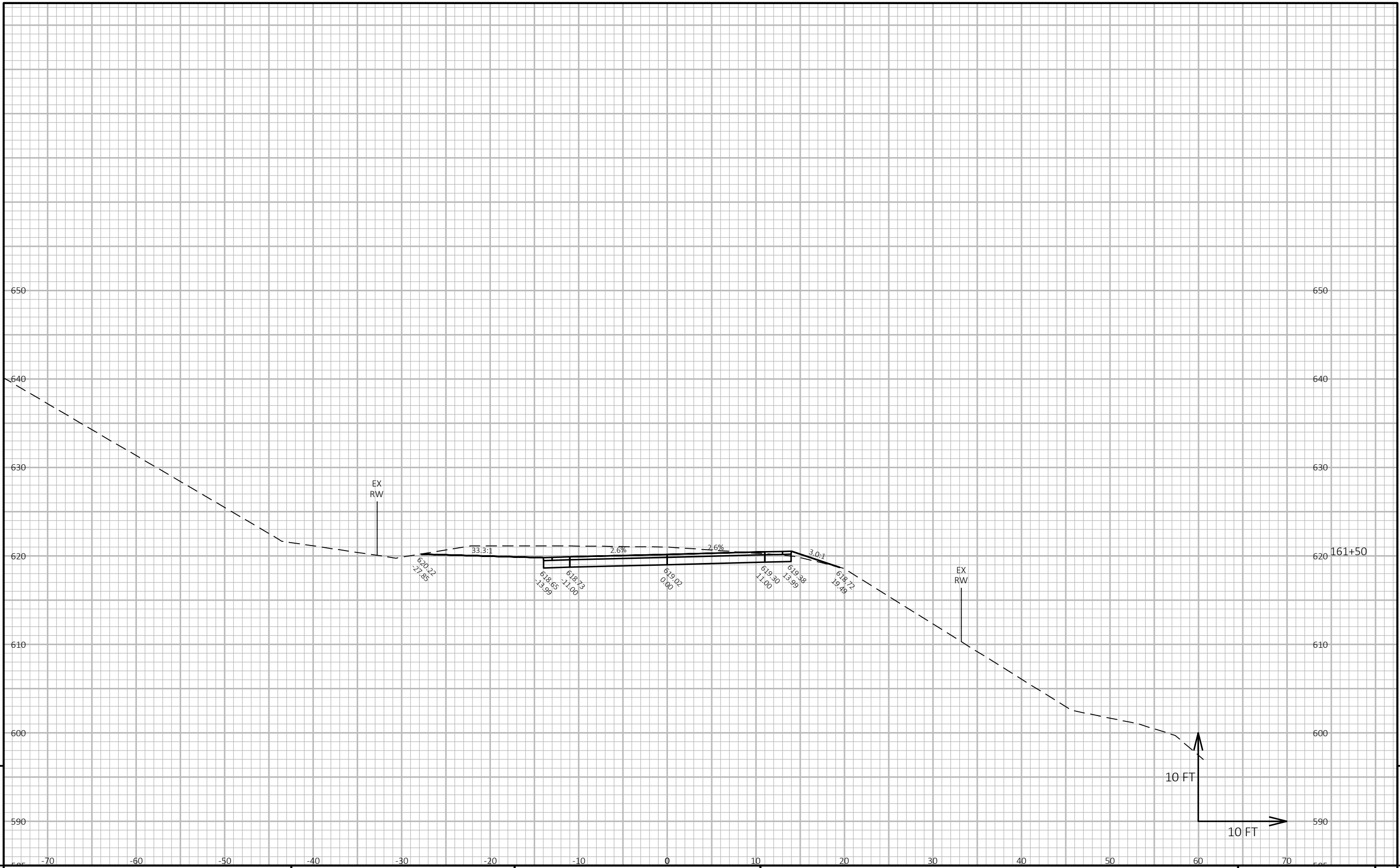

9

9

PROJECT NO: 4390-07-71      HWY: CTH C      COUNTY: KEWAUNEE      CROSS SECTIONS: SUPER SECTION      SHEET E

FILE NAME : I:\45\450511 KEWAUNEE CTH C ROADWAY\C3D\SHEETSPLAN\090201-XS.DWG      PLOT DATE : 1/9/2024 12:16 PM      PLOT BY : GARNICA, BRANDON      PLOT NAME :      PLOT SCALE : 1 IN:10 FT HORZ. / 1 IN:10 FT VERT.      WISDOT/CADD SHEET 49

LAYOUT NAME - 090282-xs

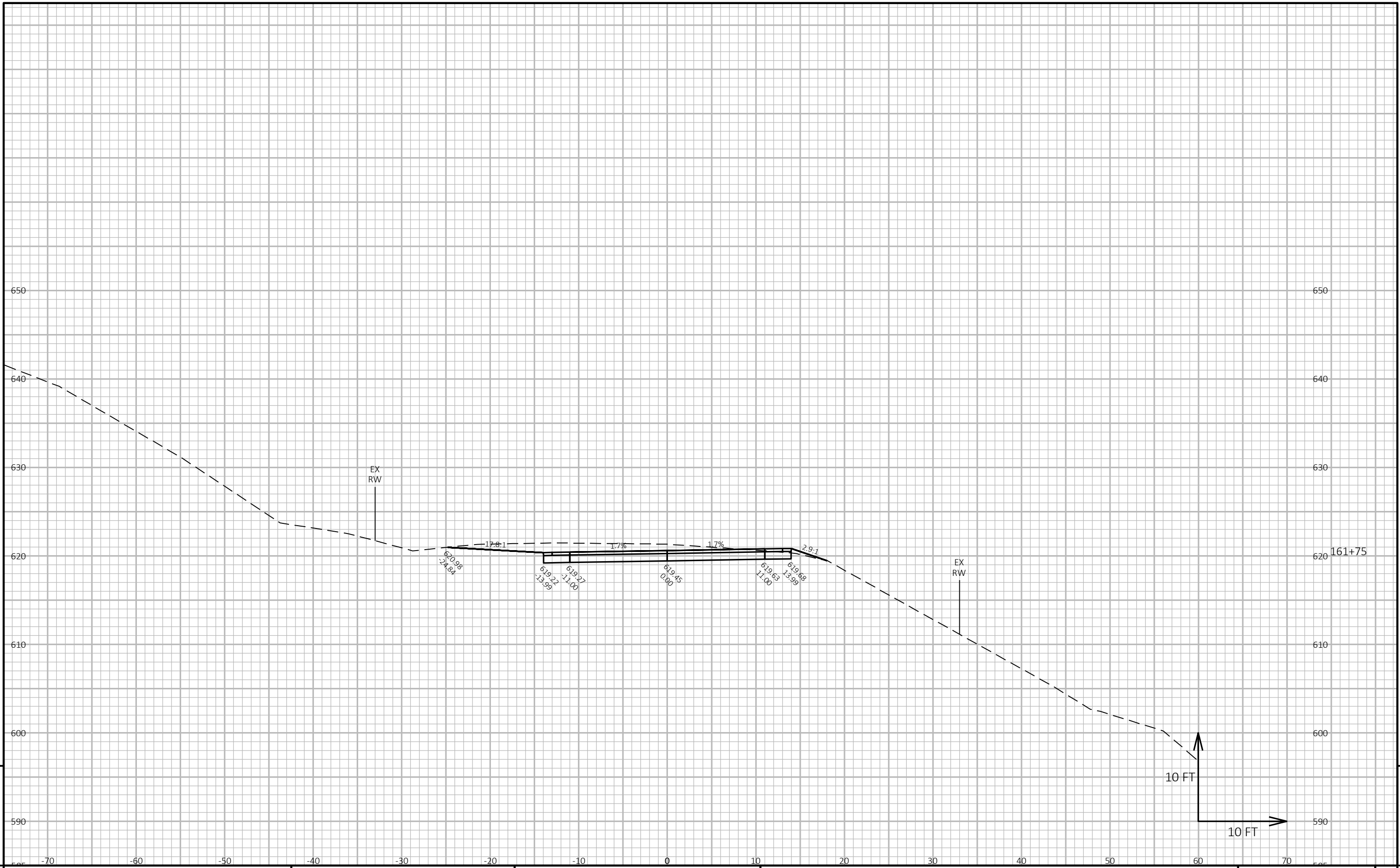

9

9

PROJECT NO: 4390-07-71	HWY: CTH C	COUNTY: KEWAUNEE	CROSS SECTIONS: SUPER SECTION	SHEET E
------------------------	------------	------------------	-------------------------------	---------

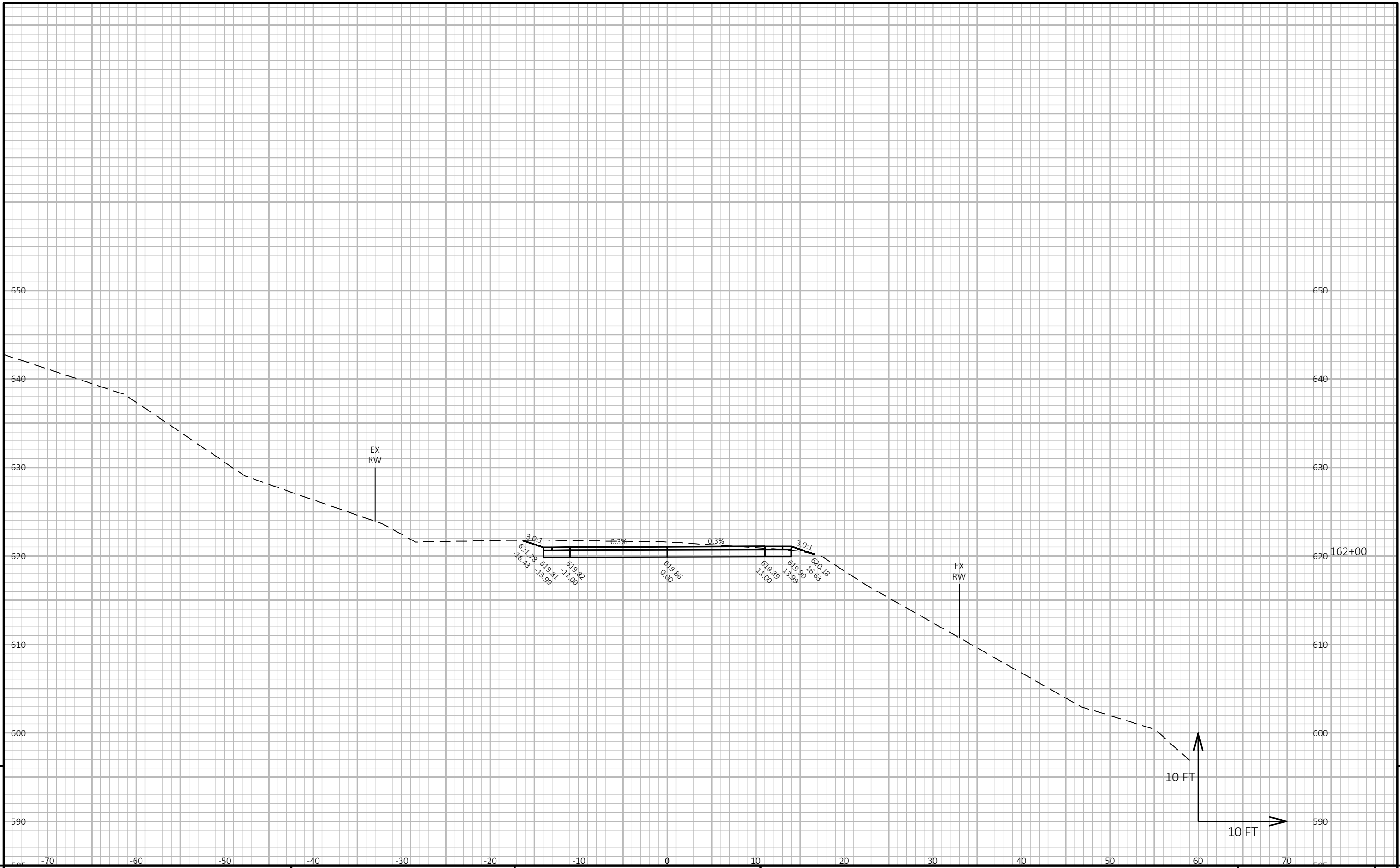

9

9

PROJECT NO: 4390-07-71      HWY: CTH C      COUNTY: KEWAUNEE      CROSS SECTIONS: SUPER SECTION      SHEET E

FILE NAME : I:\45\450511 KEWAUNEE CTH C ROADWAY\C3D\SHEETSPLAN\090201-XS.DWG      PLOT DATE : 1/9/2024 12:16 PM      PLOT BY : GARNICA, BRANDON      PLOT NAME :      PLOT SCALE : 1 IN:10 FT HORZ. / 1 IN:10 FT VERT.      WISDOT/CADD SHEET 49

LAYOUT NAME - 090284-xs

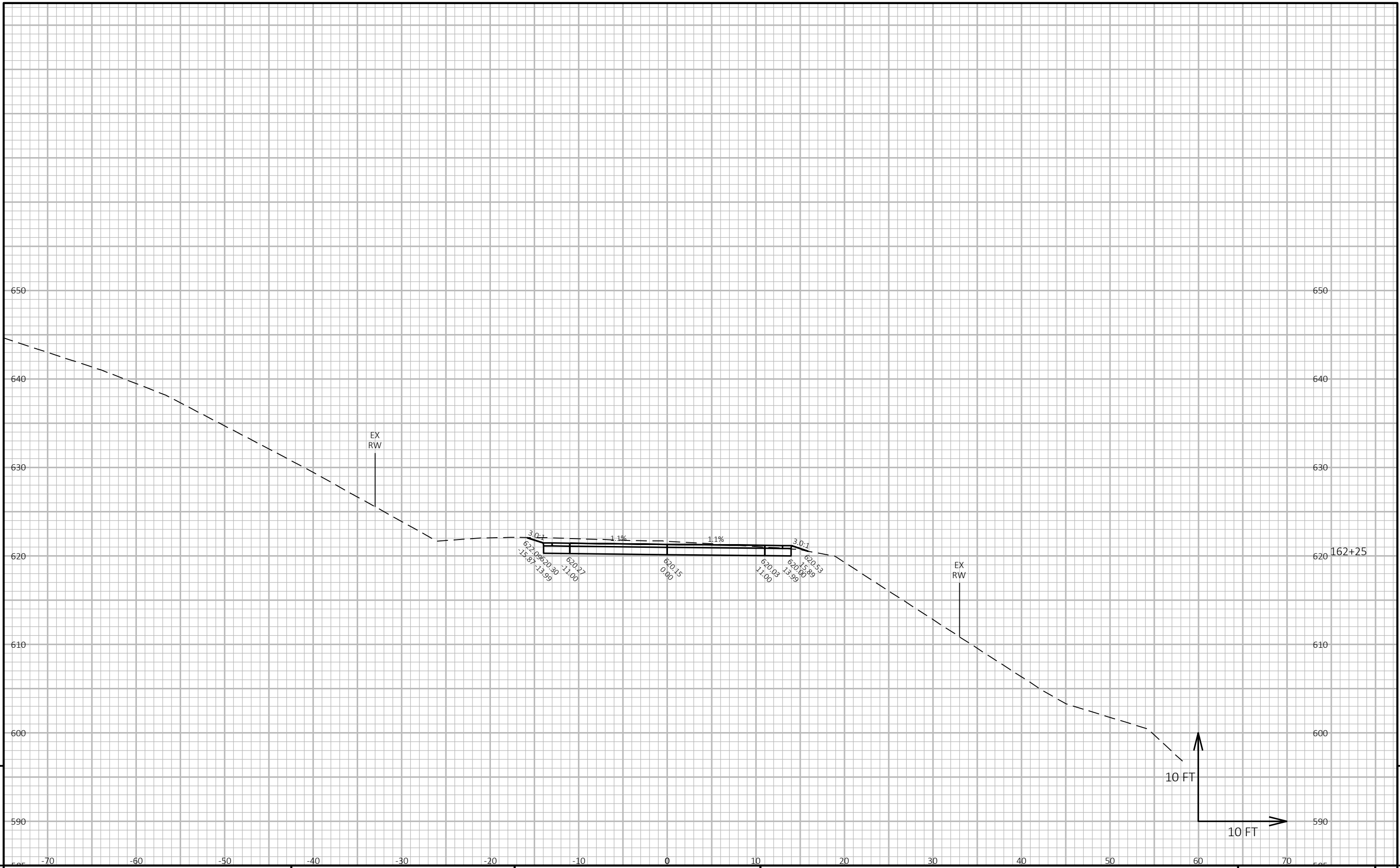

9

9

PROJECT NO: 4390-07-71	HWY: CTH C	COUNTY: KEWAUNEE	CROSS SECTIONS: SUPER SECTION	SHEET E
------------------------	------------	------------------	-------------------------------	---------

FILE NAME : I:\45\450511 KEWAUNEE CTH C ROADWAY\C3D\SHEETSPLAN\090201-XS.DWG PLOT DATE : 1/9/2024 12:16 PM PLOT BY : GARNICA, BRANDON PLOT NAME : PLOT SCALE : 1 IN:10 FT HORZ. / 1 IN:10 FT VERT. WISDOT/CADDs SHEET 49

LAYOUT NAME - 090285-xs



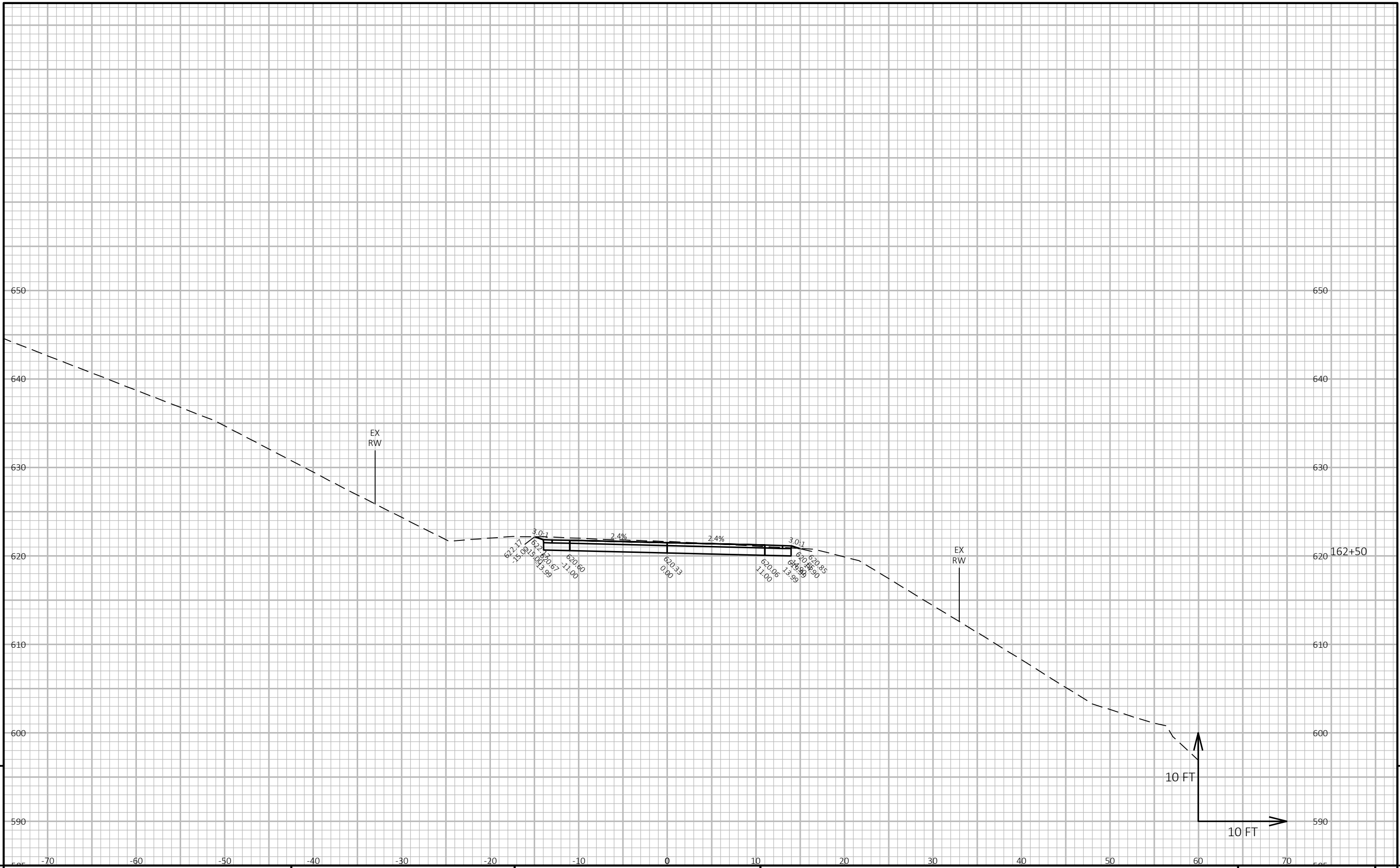

9

9

PROJECT NO: 4390-07-71	HWY: CTH C	COUNTY: KEWAUNEE	CROSS SECTIONS: SUPER SECTION	SHEET	E
------------------------	------------	------------------	-------------------------------	-------	---

FILE NAME : I:\45\450511 KEWAUNEE CTH C ROADWAY\C3D\SHEETSPLAN\090201-XS.DWG  
 LAYOUT NAME - 090286-xs  
 PLOT DATE : 1/9/2024 12:16 PM  
 PLOT BY : GARNICA, BRANDON  
 PLOT NAME :  
 PLOT SCALE : 1 IN:10 FT HORZ. / 1 IN:10 FT VERT.  
 WISDOT/CADD SHEET 49

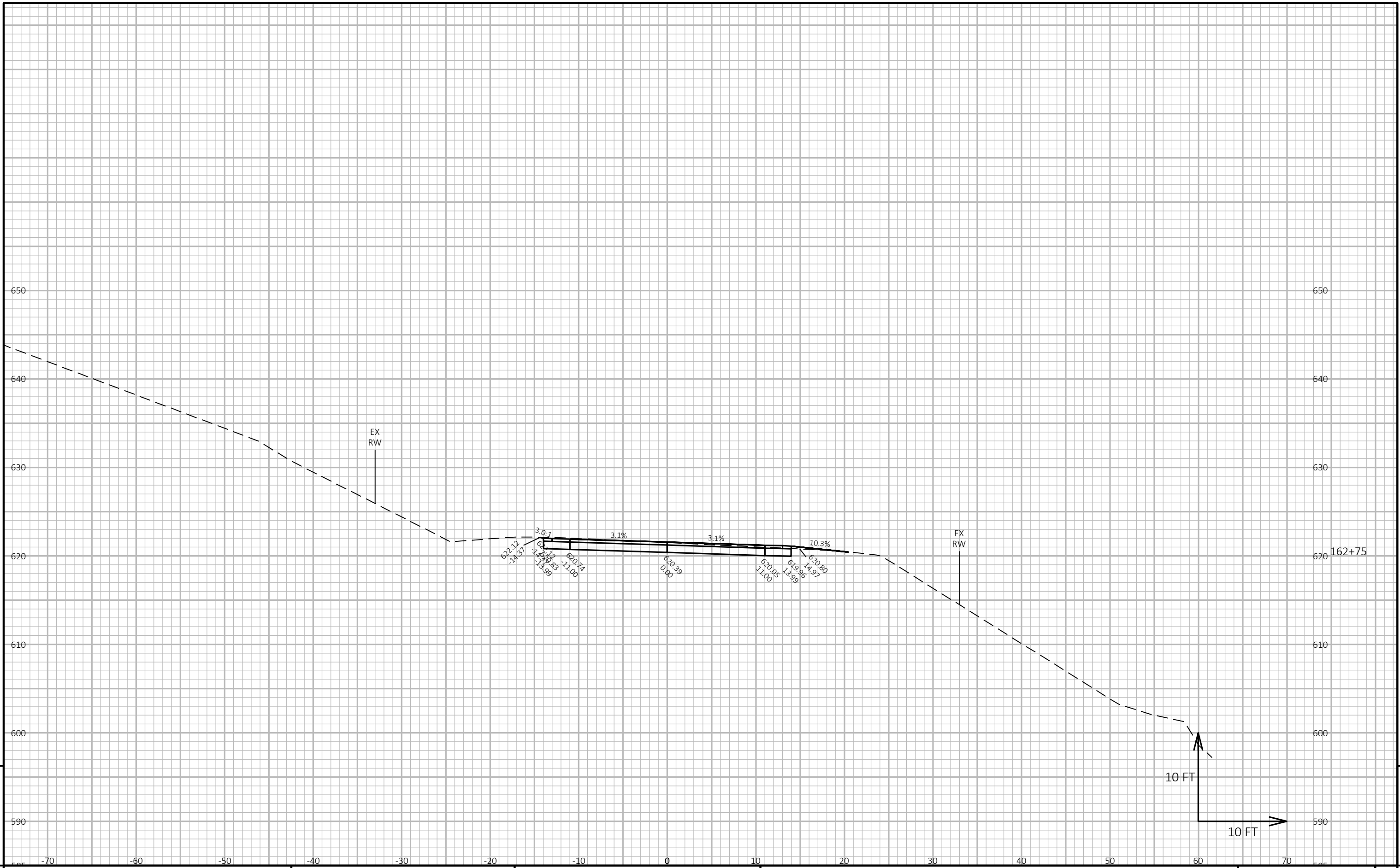

9

9

PROJECT NO: 4390-07-71	HWY: CTH C	COUNTY: KEWAUNEE	CROSS SECTIONS: SUPER SECTION	SHEET	E
------------------------	------------	------------------	-------------------------------	-------	---

FILE NAME : I:\45\450511 KEWAUNEE CTH C ROADWAY\C3D\SHEETSPLAN\090201-XS.DWG  
 LAYOUT NAME - 090287-xs  
 PLOT DATE : 1/9/2024 12:16 PM  
 PLOT BY : GARNICA, BRANDON  
 PLOT NAME :  
 PLOT SCALE : 1 IN:10 FT HORZ. / 1 IN:10 FT VERT.  
 WISDOT/CADDs SHEET 49

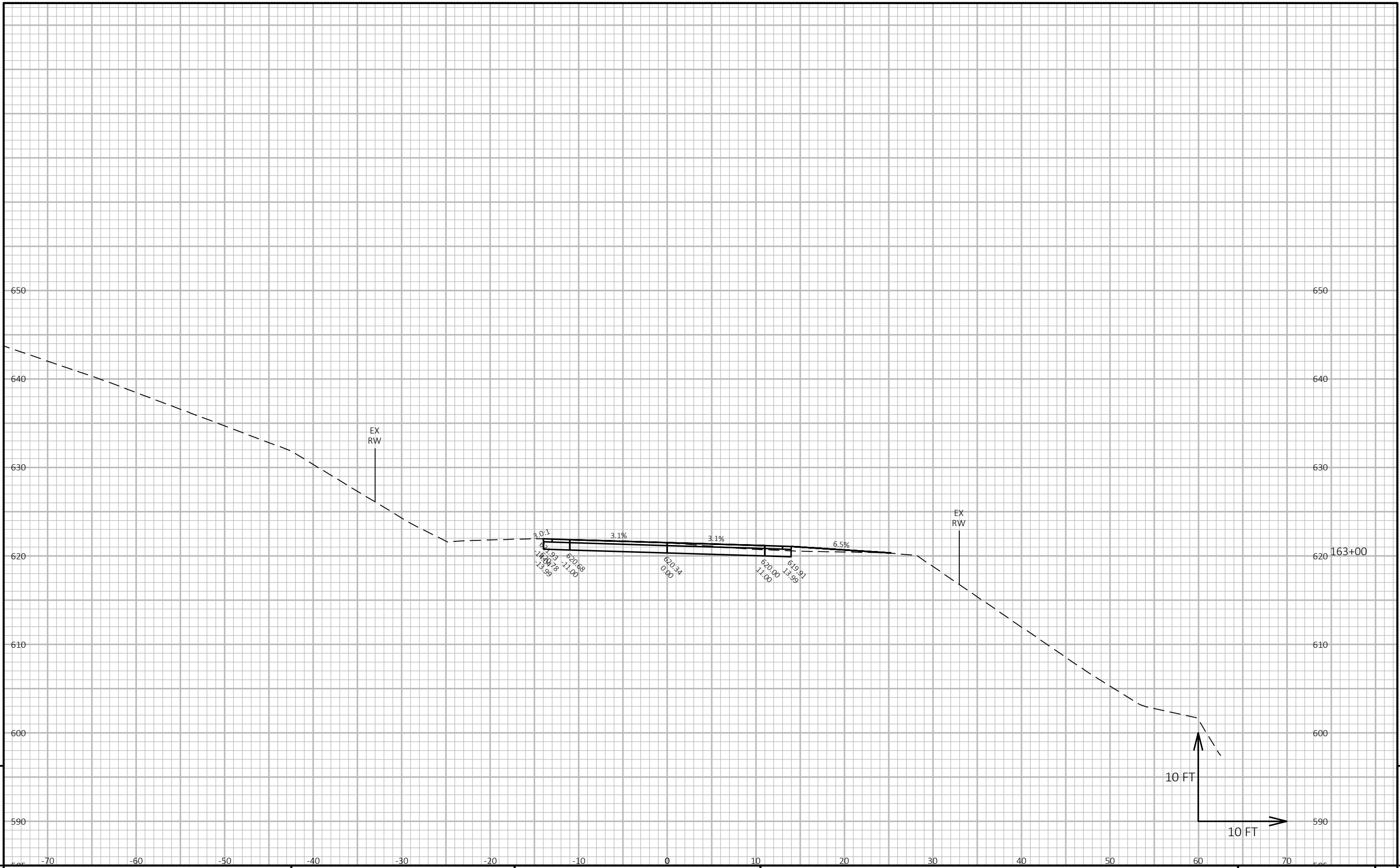

9

9

PROJECT NO: 4390-07-71	HWY: CTH C	COUNTY: KEWAUNEE	CROSS SECTIONS: SUPER SECTION	SHEET E
------------------------	------------	------------------	-------------------------------	---------

FILE NAME : I:\45\450511 KEWAUNEE CTH C ROADWAY\C3D\SHEETSPLAN\090201-XS.DWG  
 LAYOUT NAME - 090288-xs  
 PLOT DATE : 1/9/2024 12:16 PM  
 PLOT BY : GARNICA, BRANDON  
 PLOT NAME :  
 PLOT SCALE : 1 IN:10 FT HORZ. / 1 IN:10 FT VERT.  
 WISDOT/CADDs SHEET 49

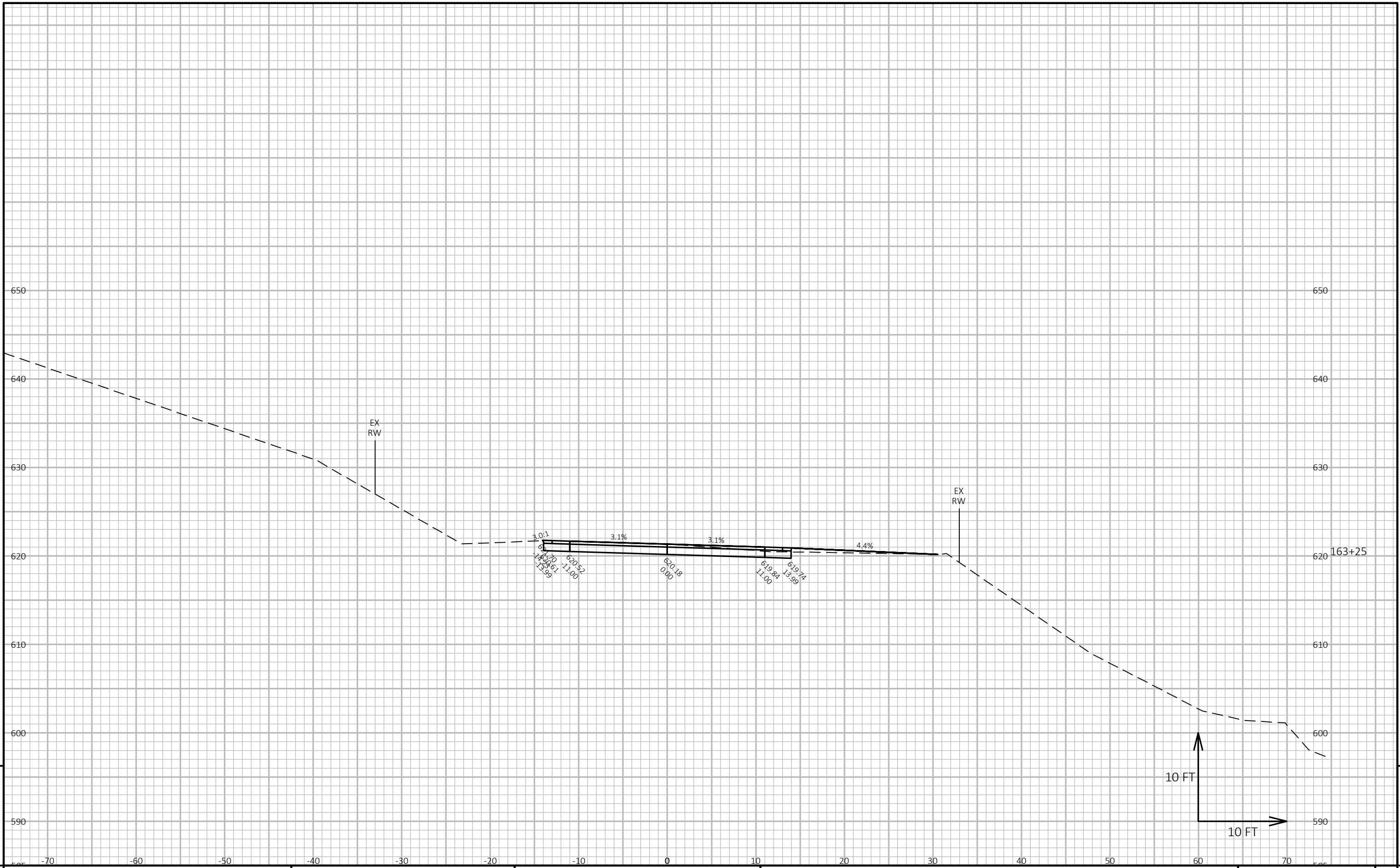

9

9

PROJECT NO: 4390-07-71	HWY: CTH C	COUNTY: KEWAUNEE	CROSS SECTIONS: SUPER SECTION	SHEET	E
------------------------	------------	------------------	-------------------------------	-------	---

FILE NAME : I:\45\450511 KEWAUNEE CTH C ROADWAY\C3D\SHEETSPLAN\090201-XS.DWG  
LAYOUT NAME - 090289-xs

PLOT DATE : 1/9/2024 12:16 PM

PLOT BY : GARNICA, BRANDON

PLOT NAME :

PLOT SCALE : 1 IN:10 FT HORZ. / 1 IN:10 FT VERT.

WISDOT/CADDs SHEET 49

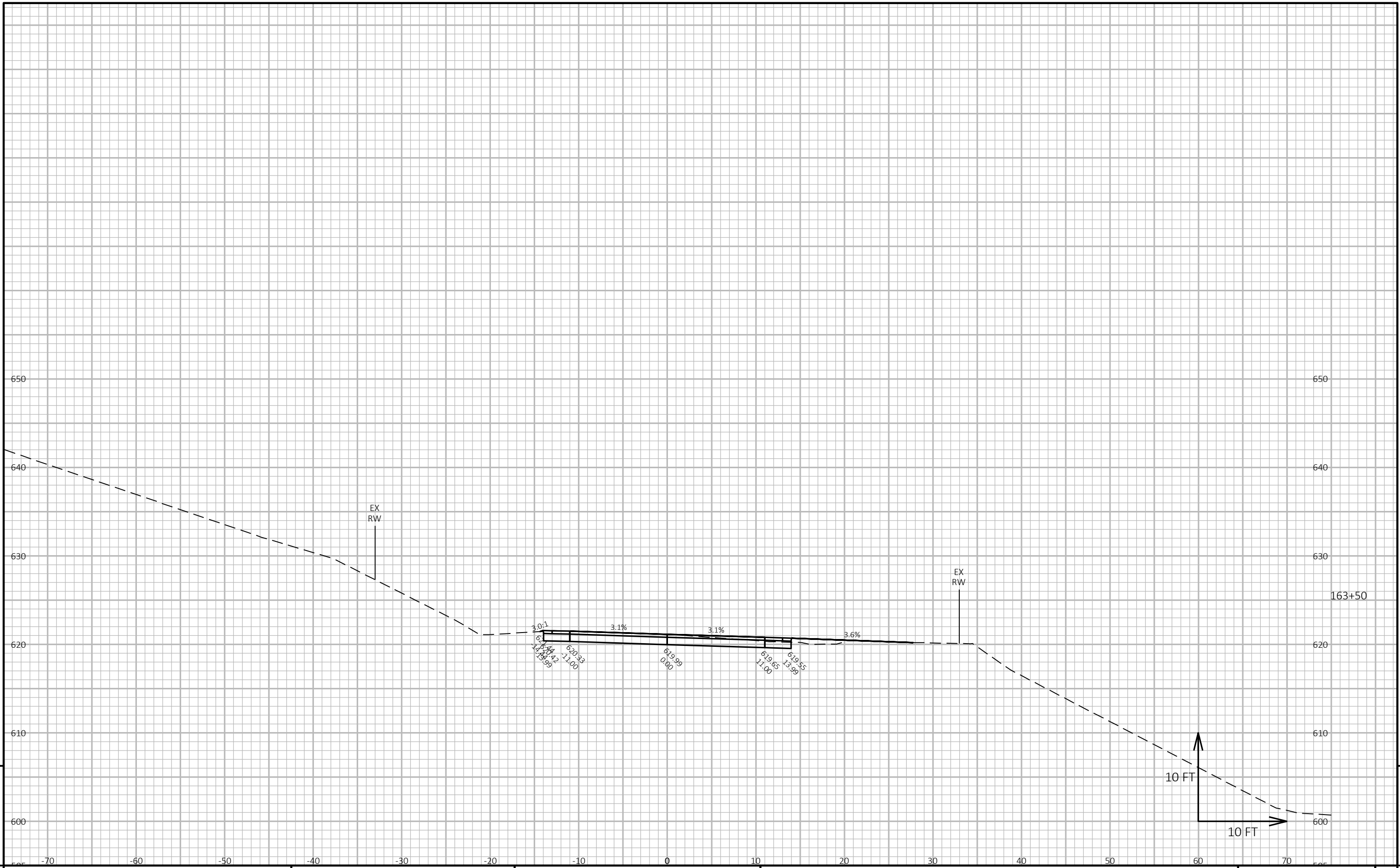

9

9

PROJECT NO: 4390-07-71	HWY: CTH C	COUNTY: KEWAUNEE	CROSS SECTIONS: SUPER SECTION	SHEET E
------------------------	------------	------------------	-------------------------------	---------

FILE NAME : I:\45\450511 KEWAUNEE CTH C ROADWAY\C3D\SHEETSPLAN\090201-XS.DWG PLOT DATE : 1/9/2024 12:17 PM PLOT BY : GARNICA, BRANDON PLOT NAME : PLOT SCALE : 1 IN:10 FT HORZ. / 1 IN:10 FT VERT. WISDOT/CADD SHEET 49

LAYOUT NAME - 090290-xs

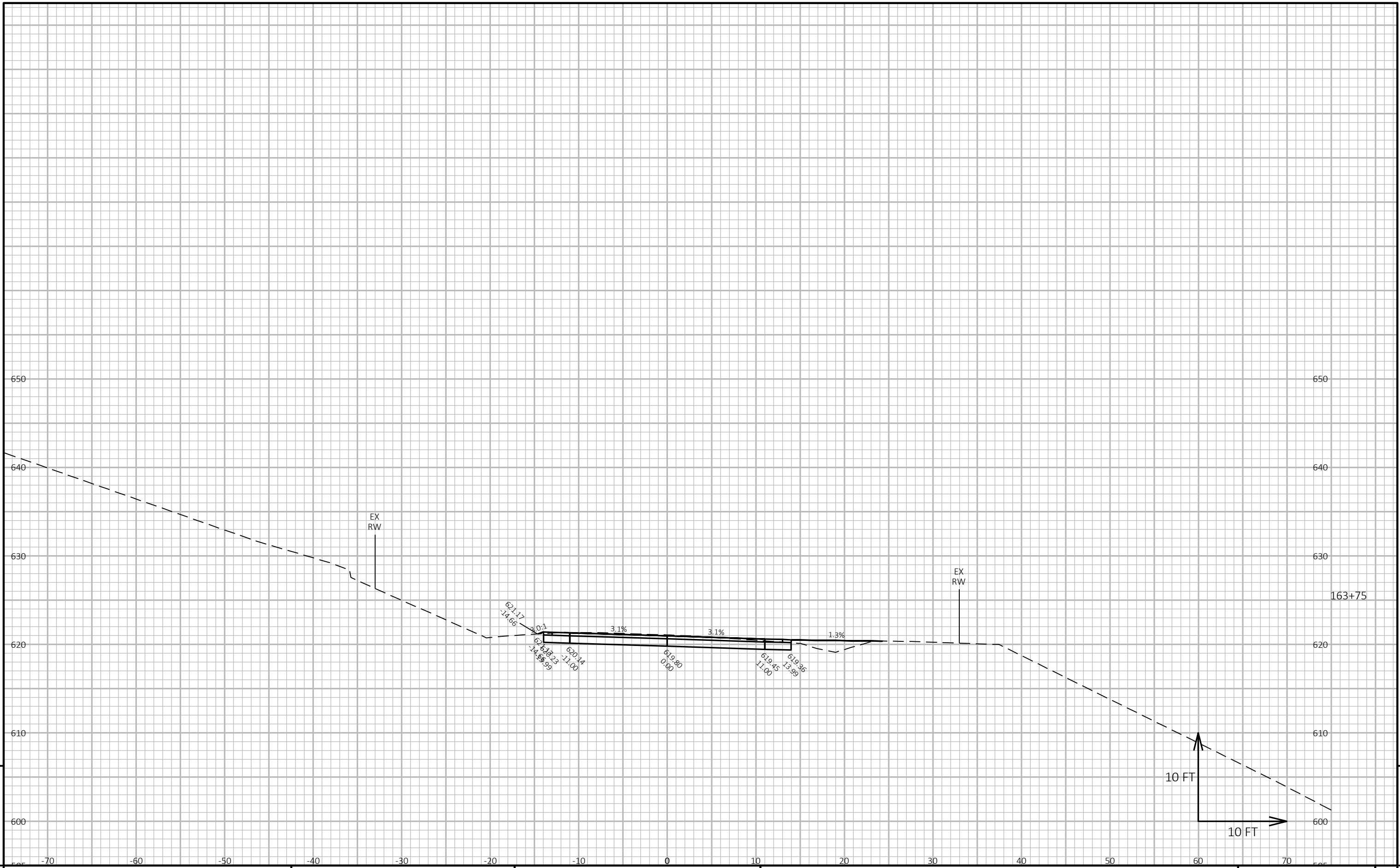

PROJECT NO: 4390-07-71	HWY: CTH C	COUNTY: KEWAUNEE	CROSS SECTIONS: SUPER SECTION	SHEET E
------------------------	------------	------------------	-------------------------------	---------

9

9

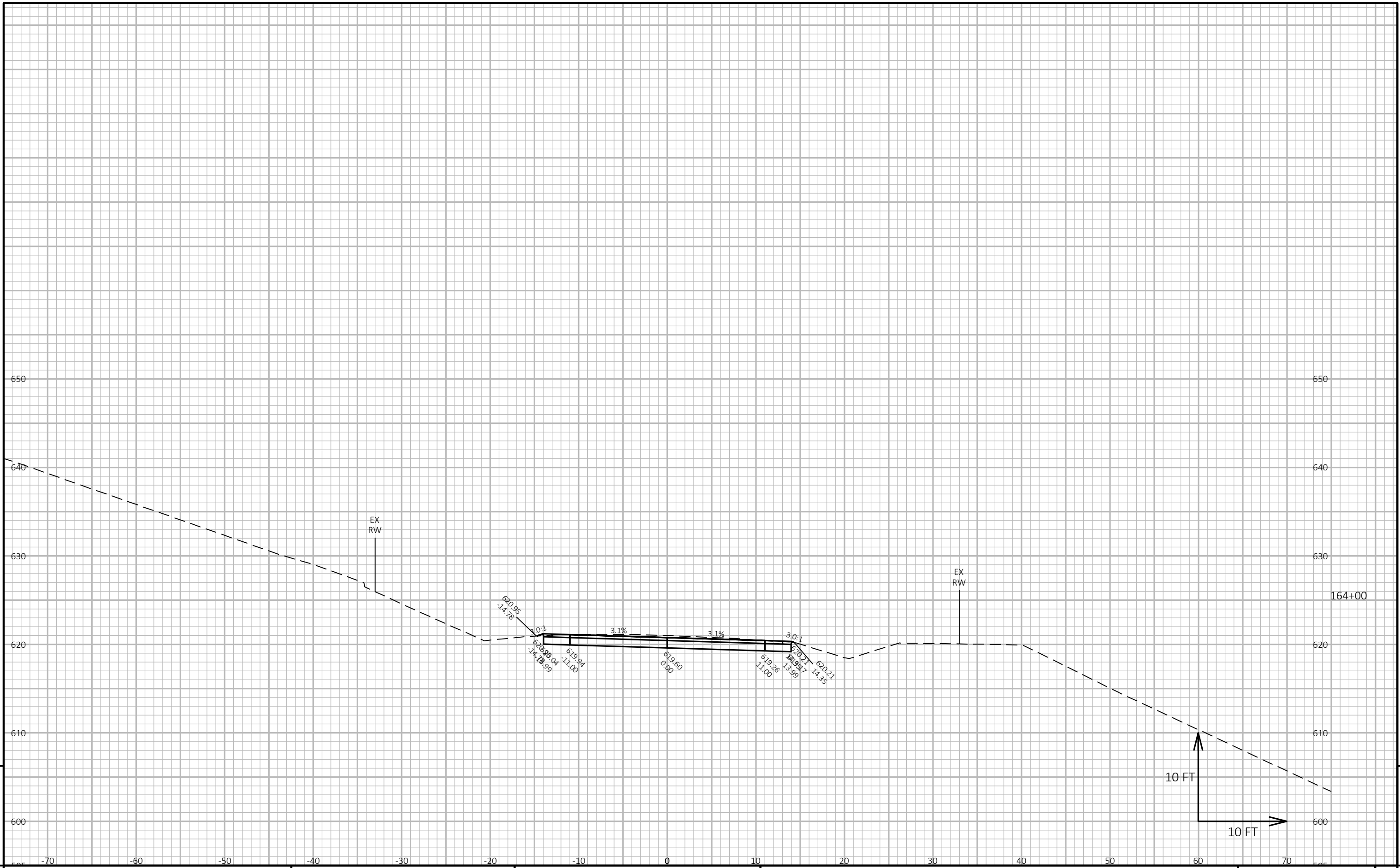

9

9

PROJECT NO: 4390-07-71      HWY: CTH C      COUNTY: KEWAUNEE      CROSS SECTIONS: SUPER SECTION      SHEET E

FILE NAME: I:\45\450511 KEWAUNEE CTH C ROADWAY\C3D\SHEETSPLAN\090201-XS.DWG      PLOT DATE: 1/9/2024 12:17 PM      PLOT BY: GARNICA, BRANDON      PLOT NAME:      PLOT SCALE: 1 IN:10 FT HORZ. / 1 IN:10 FT VERT.      WISDOT/CADD SHEET 49

LAYOUT NAME - 090292-xs

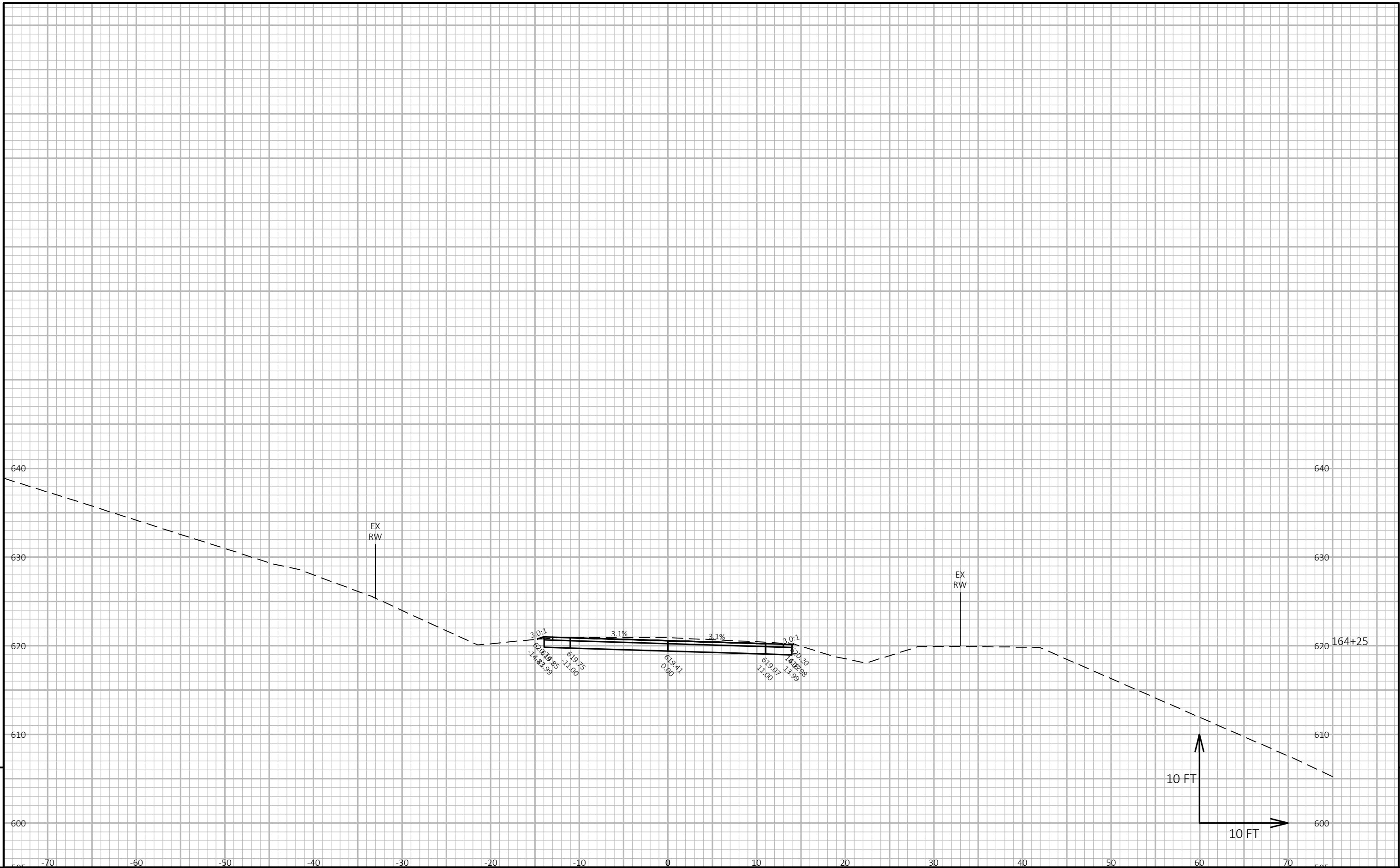

9

9

PROJECT NO: 4390-07-71

HWY: CTH C

COUNTY: KEWAUNEE

CROSS SECTIONS: SUPER SECTION

SHEET

E





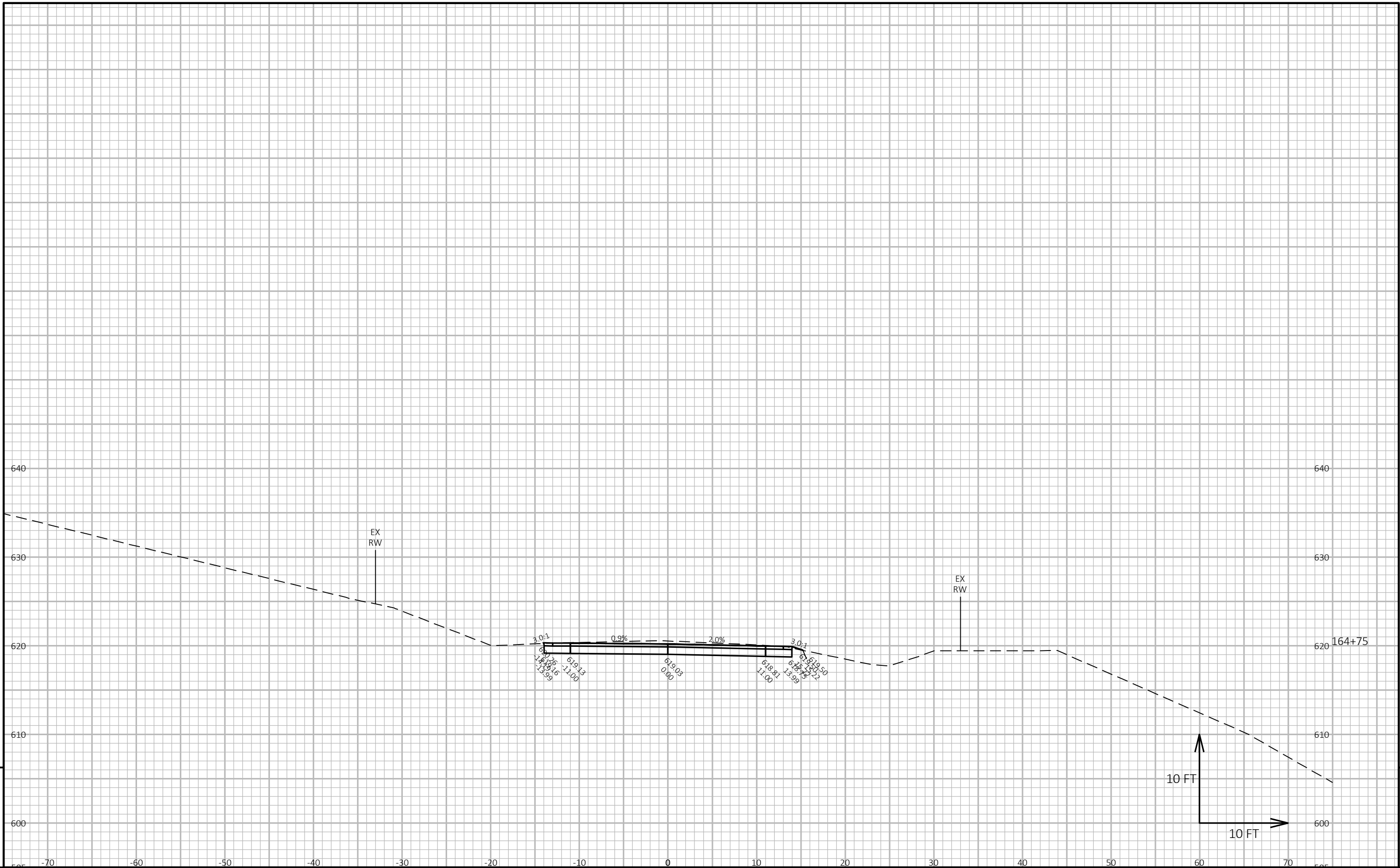

9

9

PROJECT NO: 4390-07-71	HWY: CTH C	COUNTY: KEWAUNEE	CROSS SECTIONS: SUPER SECTION	SHEET E
------------------------	------------	------------------	-------------------------------	---------

FILE NAME : I:\45\450511 KEWAUNEE CTH C ROADWAY\C3D\SHEETSPLAN\090201-XS.DWG  
 LAYOUT NAME - 090295-xs  
 PLOT DATE : 1/9/2024 12:17 PM  
 PLOT BY : GARNICA, BRANDON  
 PLOT NAME :  
 PLOT SCALE : 1 IN:10 FT HORZ. / 1 IN:10 FT VERT.  
 WISDOT/CADDs SHEET 49

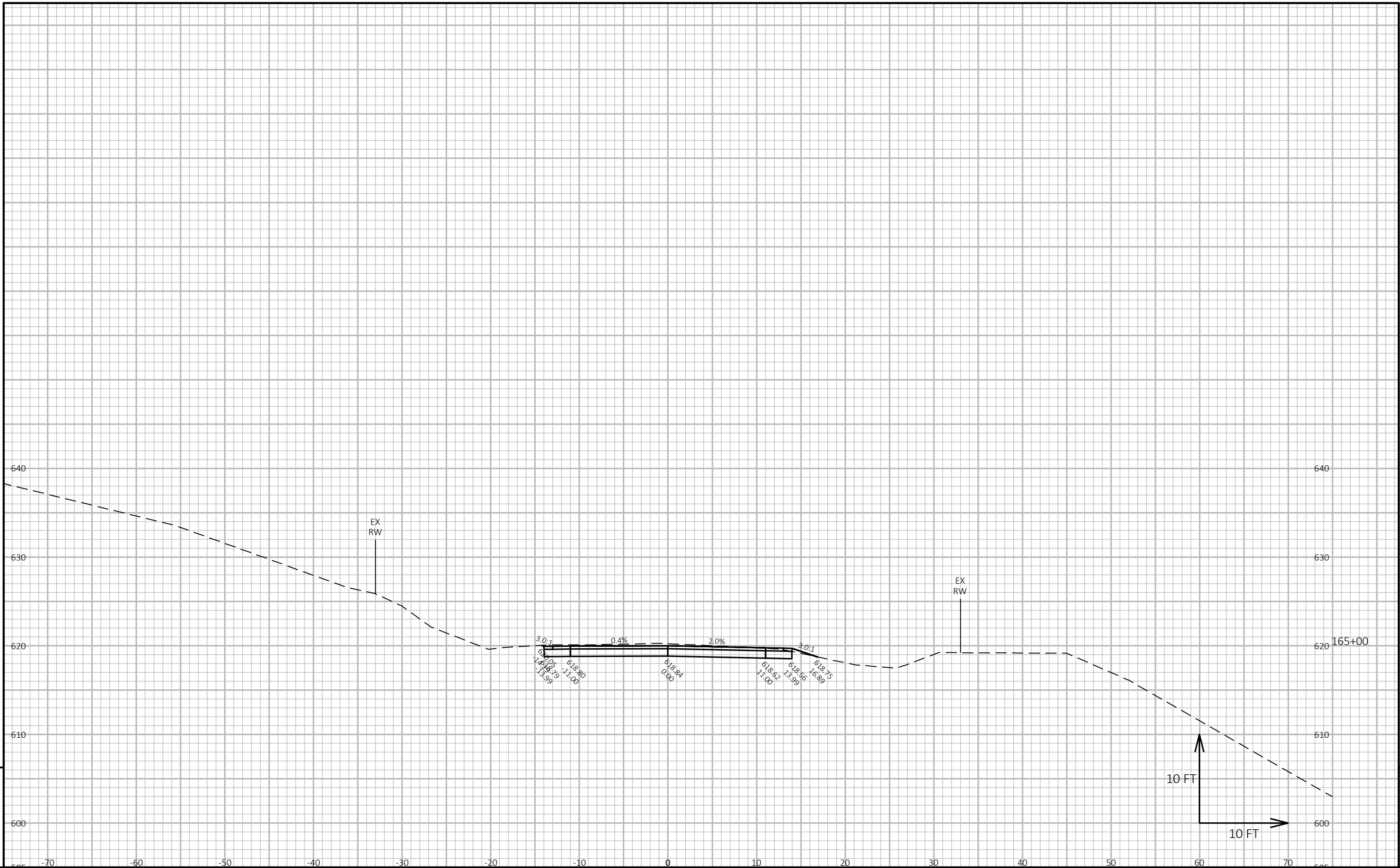

9

9

PROJECT NO: 4390-07-71      HWY: CTH C      COUNTY: KEWAUNEE      CROSS SECTIONS: SUPER SECTION      SHEET E

FILE NAME: I:\45\450511 KEWAUNEE CTH C ROADWAY\C3D\SHEETSPLAN\090201-XS.DWG      PLOT DATE: 1/9/2024 12:17 PM      PLOT BY: GARNICA, BRANDON      PLOT NAME:      PLOT SCALE: 1 IN:10 FT HORZ. / 1 IN:10 FT VERT.      WISDOT/CADD SHEET 49

LAYOUT NAME - 090296-xs

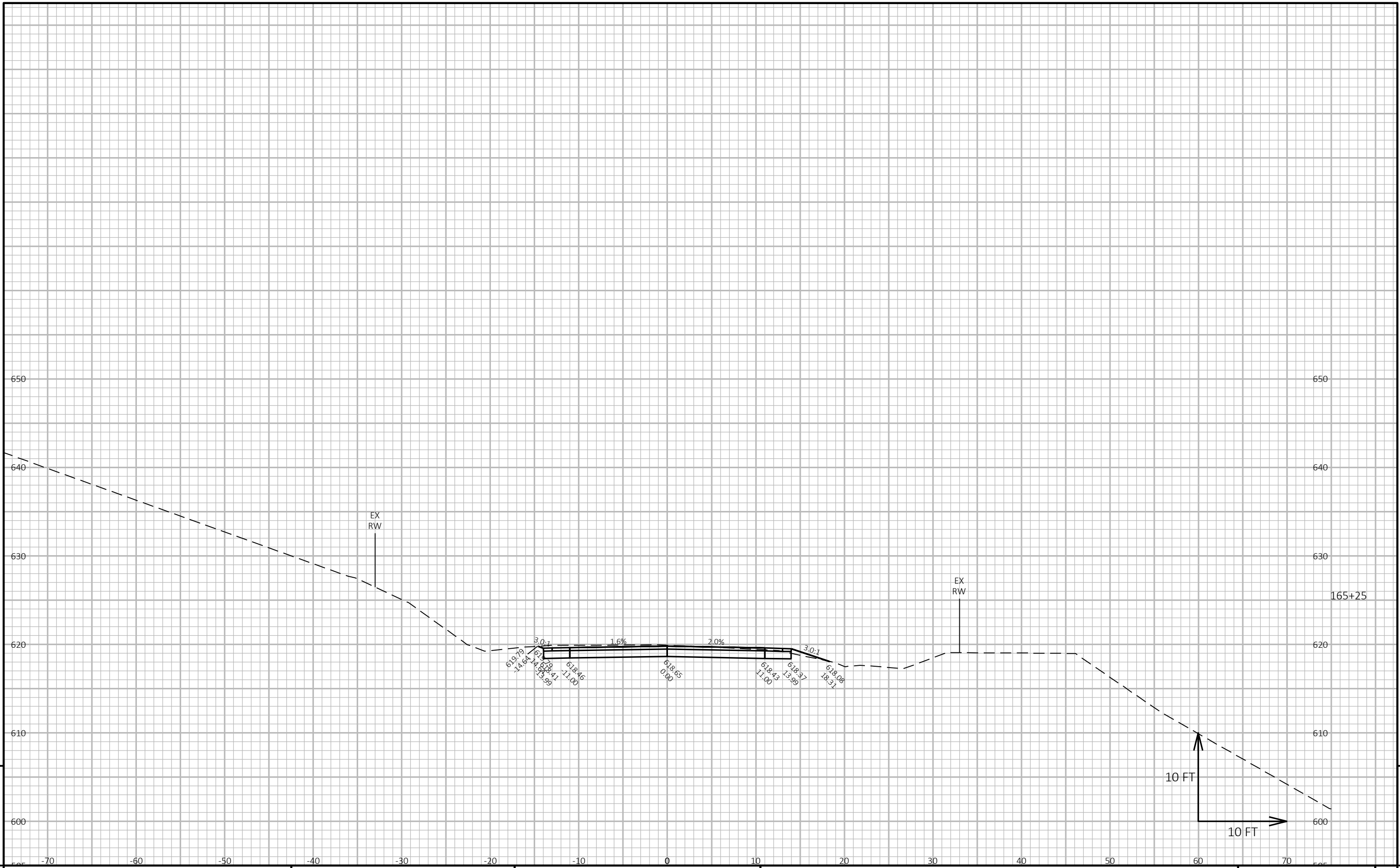

9

9

PROJECT NO: 4390-07-71	HWY: CTH C	COUNTY: KEWAUNEE	CROSS SECTIONS: SUPER SECTION	SHEET	E
------------------------	------------	------------------	-------------------------------	-------	---

FILE NAME : I:\45\450511 KEWAUNEE CTH C ROADWAY\C3D\SHEETSPLAN\090201-XS.DWG  
 LAYOUT NAME - 090297-xs  
 PLOT DATE : 1/9/2024 12:17 PM  
 PLOT BY : GARNICA, BRANDON  
 PLOT NAME :  
 PLOT SCALE : 1 IN:10 FT HORZ. / 1 IN:10 FT VERT.  
 WISDOT/CADD SHEET 49



9

9

PROJECT NO: 4390-07-71	HWY: CTH C	COUNTY: KEWAUNEE	CROSS SECTIONS: SUPER SECTION	SHEET	E
------------------------	------------	------------------	-------------------------------	-------	---

FILE NAME : I:\45\450511 KEWAUNEE CTH C ROADWAY\C3D\SHEETSPLAN\090201-XS.DWG  
 LAYOUT NAME - 090298-xs  
 PLOT DATE : 1/9/2024 12:17 PM  
 PLOT BY : GARNICA, BRANDON  
 PLOT NAME :  
 PLOT SCALE : 1 IN:10 FT HORZ. / 1 IN:10 FT VERT.  
 WISDOT/CADD SHEET 49

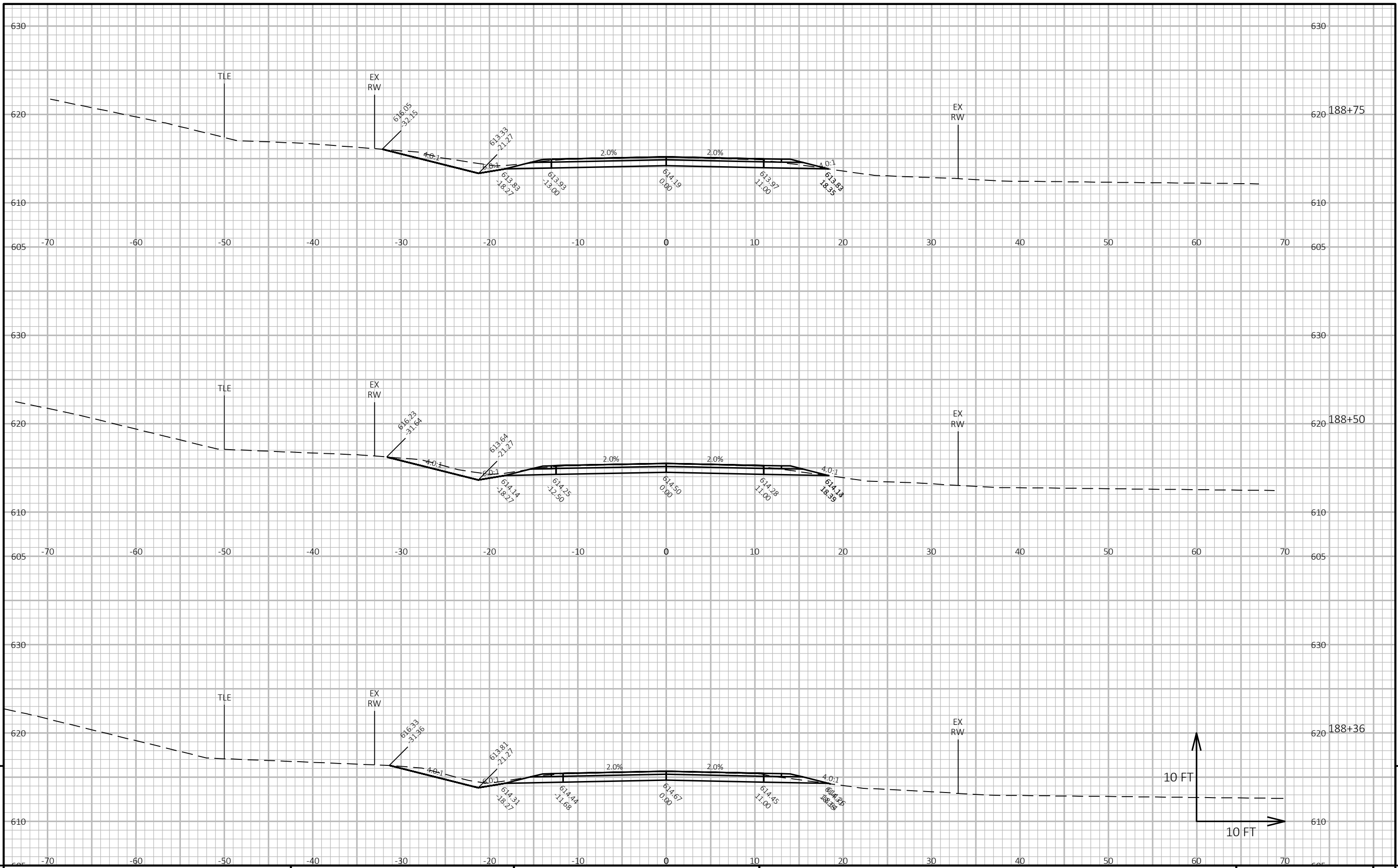

PROJECT NO: 4390-07-71      HWY: CTH C      COUNTY: KEWAUNEE      CROSS SECTIONS: URBAN      SHEET 9

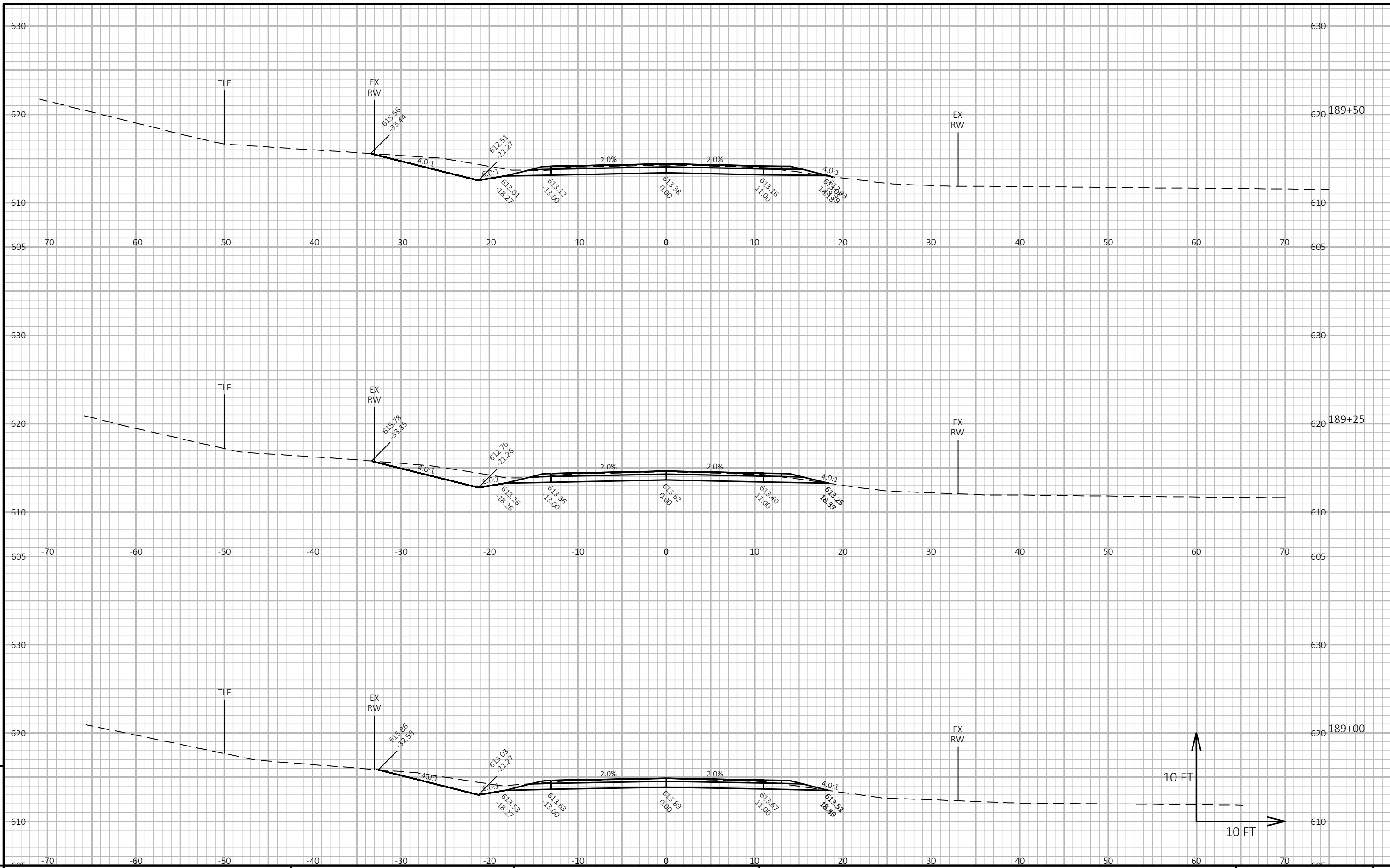

PROJECT NO: 4390-07-71      HWY: CTH C      COUNTY: KEWAUNEE      CROSS SECTIONS: URBAN      SHEET 9

FILE NAME: I:\451450511 KEWAUNEE CTH C ROADWAY\C3D\SHEETSPLAN\090201-XS.DWG      PLOT DATE: 1/9/2024 12:17 PM      PLOT BY: GARNICA, BRANDON      PLOT NAME:      PLOT SCALE: 1 IN:10 FT HORZ. / 1 IN:10 FT VERT.      WISDOT/CADD SHEET 49

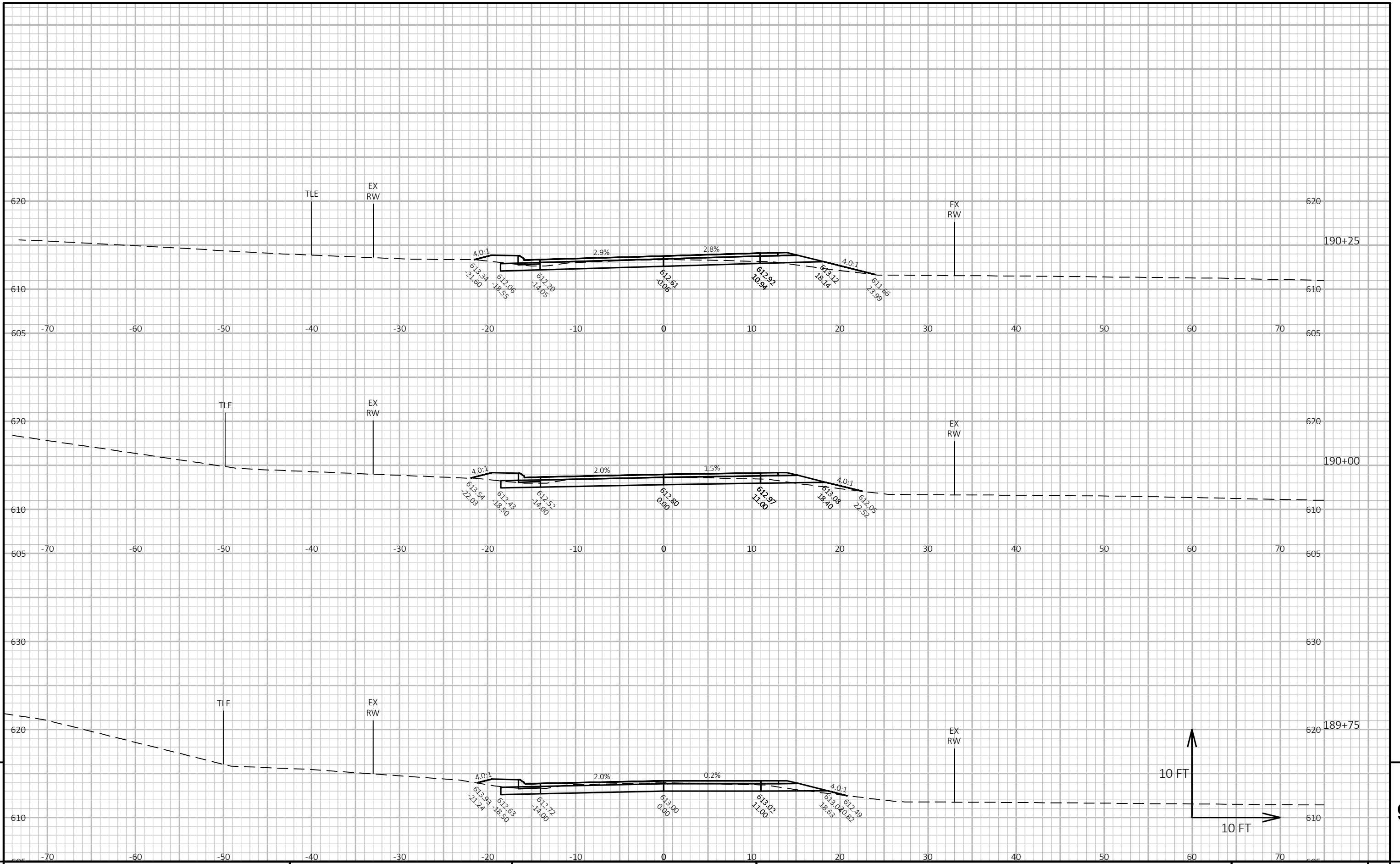

PROJECT NO: 4390-07-71      HWY: CTH C      COUNTY: KEWAUNEE      CROSS SECTIONS: URBAN      SHEET      E



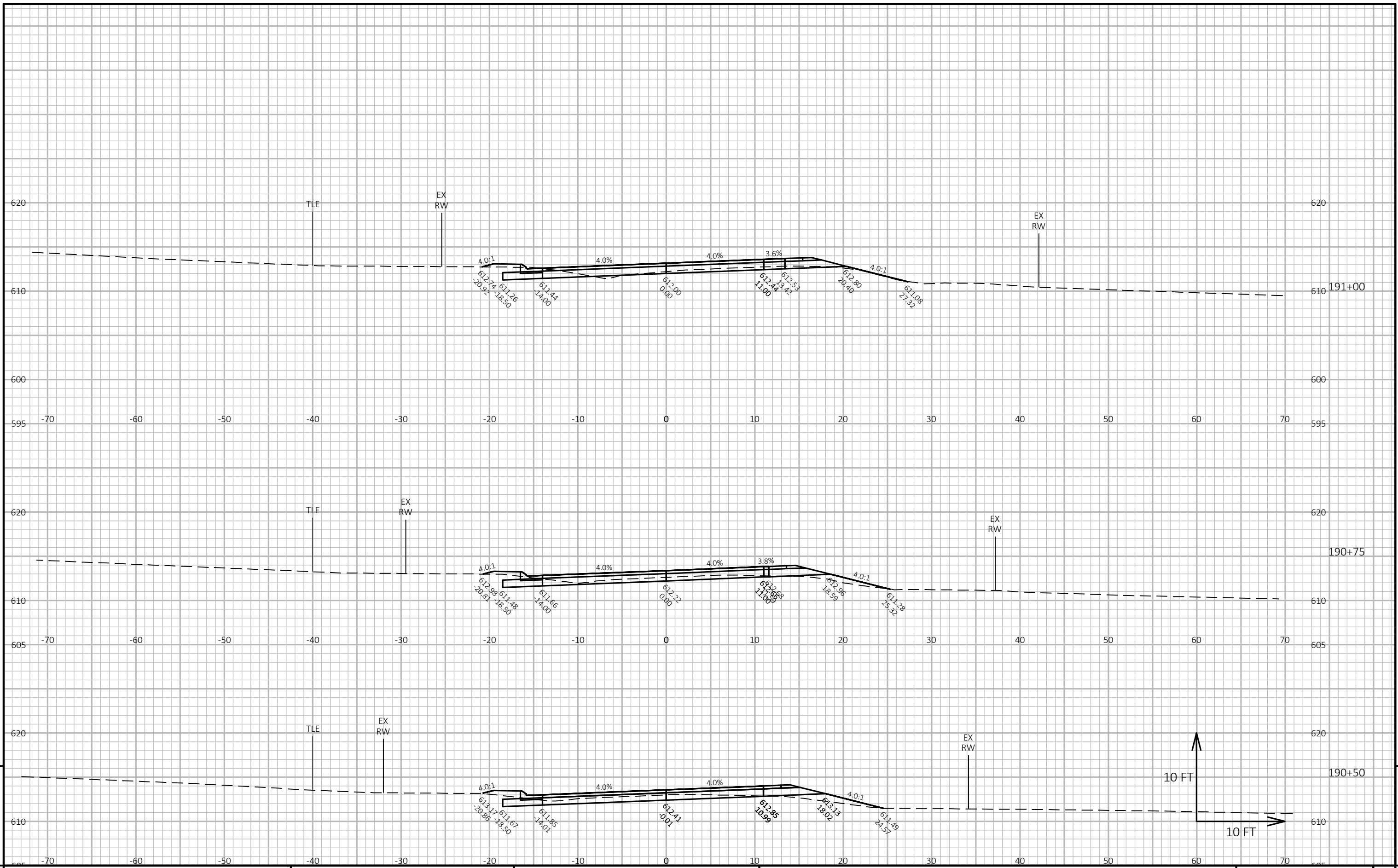

PROJECT NO: 4390-07-71      HWY: CTH C      COUNTY: KEWAUNEE      CROSS SECTIONS: URBAN      SHEET 9

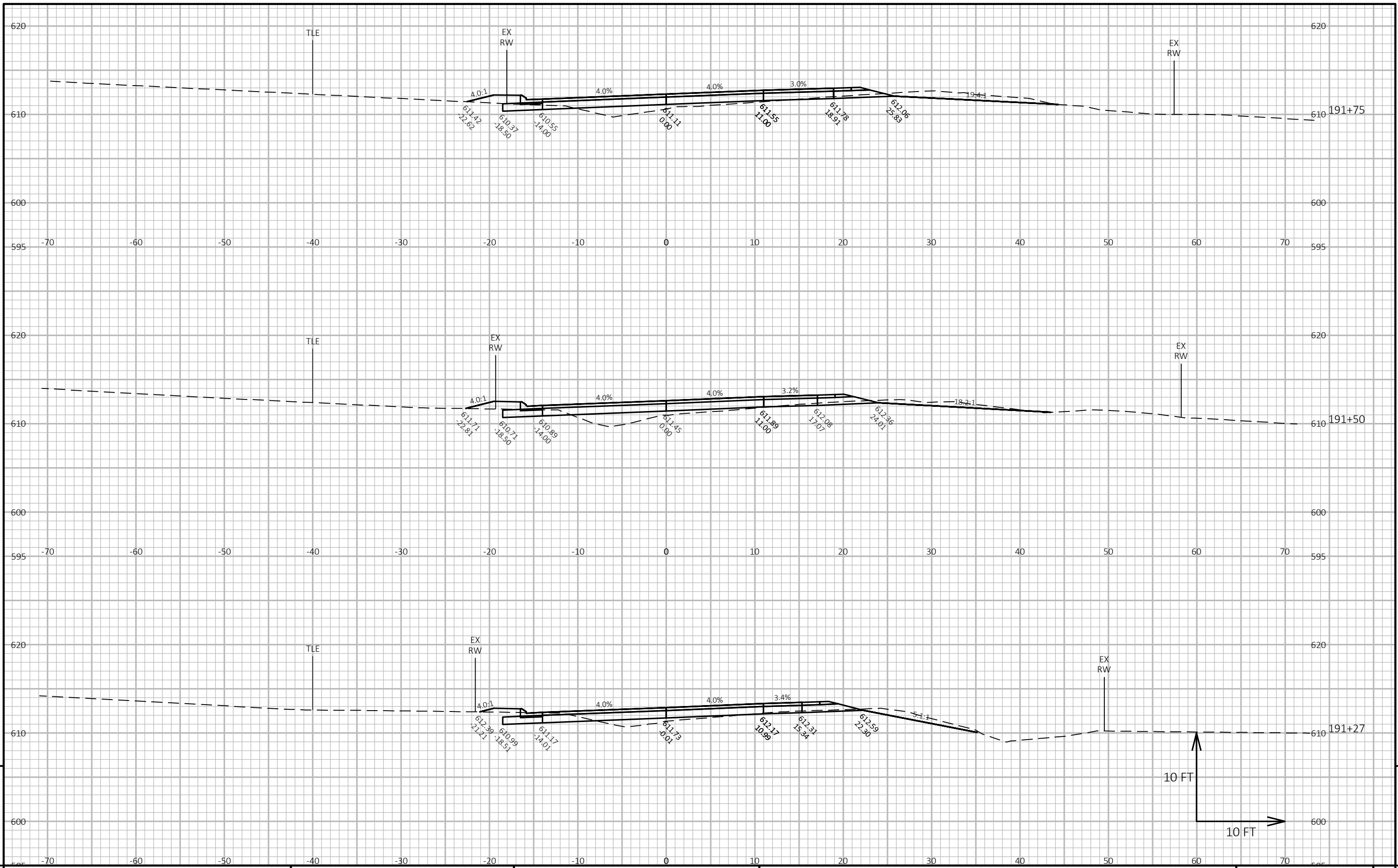

9

9

PROJECT NO: 4390-07-71      HWY: CTH C      COUNTY: KEWAUNEE      CROSS SECTIONS: URBAN      SHEET E

FILE NAME: I:\45\450511 KEWAUNEE CTH C ROADWAY\C3D\SHEETSPLAN\090201-XS.DWG      PLOT DATE: 1/9/2024 12:18 PM      PLOT BY: GARNICA, BRANDON      PLOT NAME:      PLOT SCALE: 1 IN:10 FT HORZ. / 1 IN:10 FT VERT.      WISDOT/CADD SHEET 49

LAYOUT NAME - 090216-xs

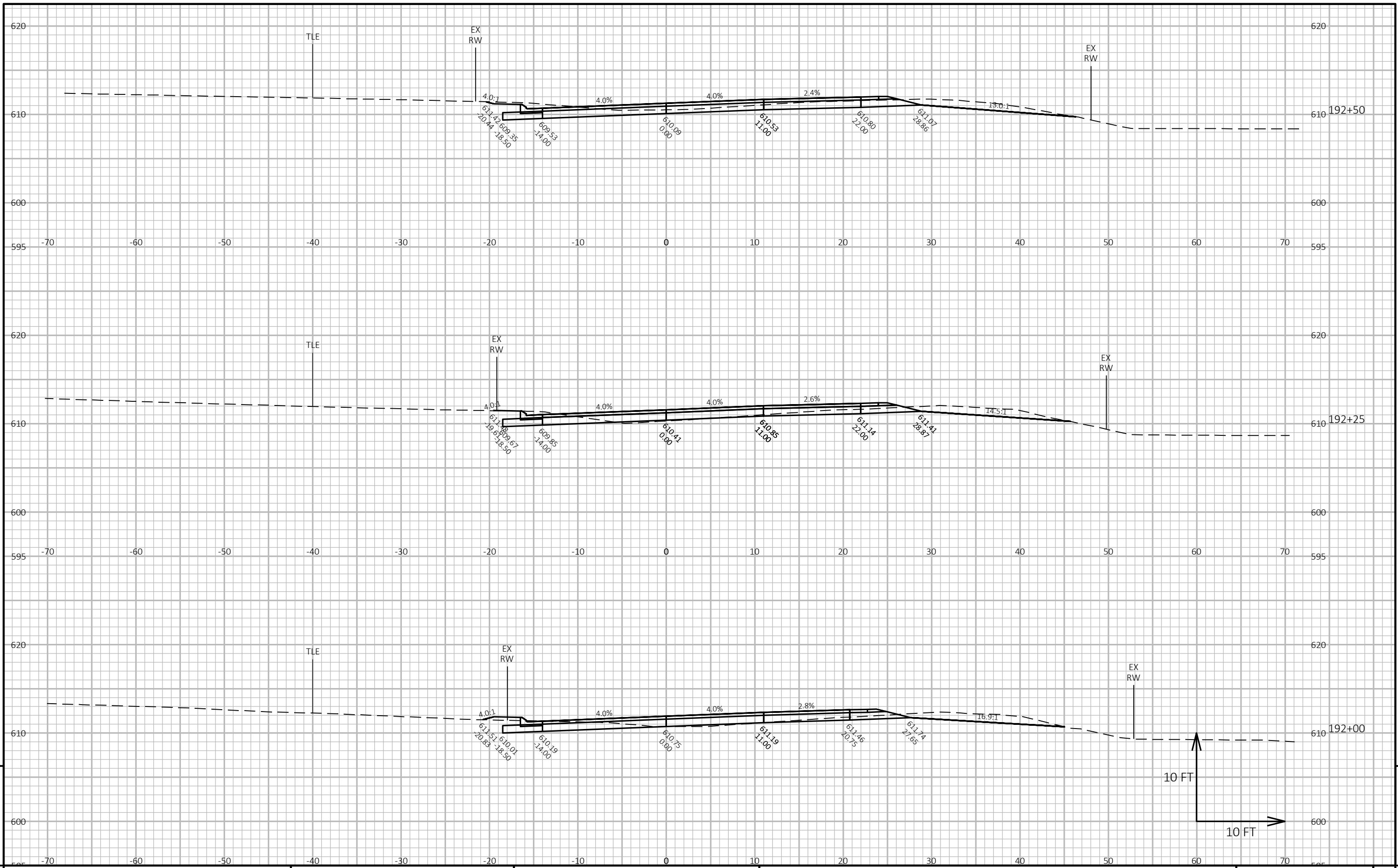

PROJECT NO: 4390-07-71	HWY: CTH C	COUNTY: KEWAUNEE	CROSS SECTIONS: URBAN	SHEET	E
------------------------	------------	------------------	-----------------------	-------	---

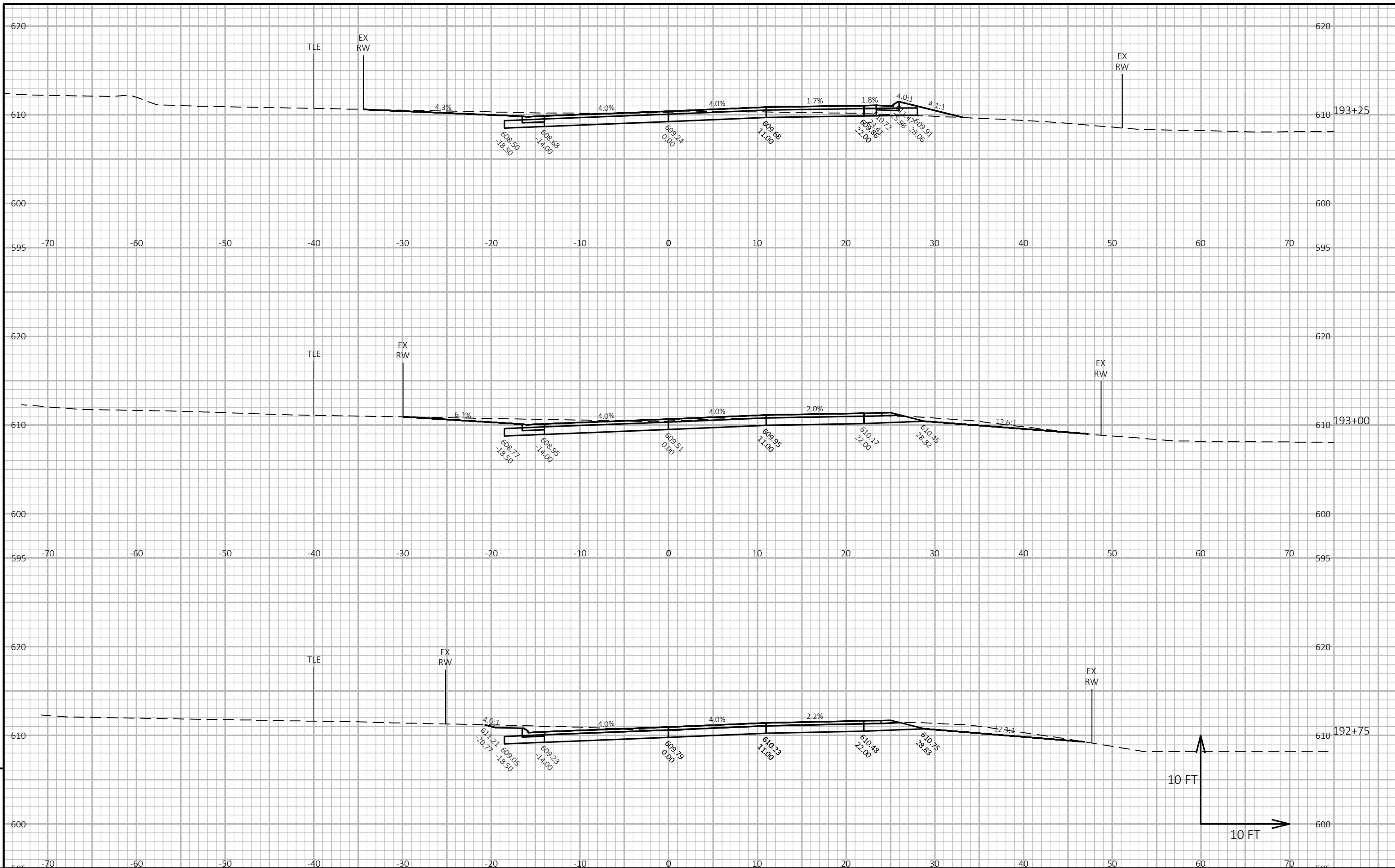

9

9

PROJECT NO: 4390-07-71      HWY: CTH C      COUNTY: KEWAUNEE      CROSS SECTIONS: URBAN      SHEET E

FILE NAME: I:\45\450511 KEWAUNEE CTH C ROADWAY\C3D\SHEETSPLAN\090201-XS.DWG      PLOT DATE: 1/9/2024 12:18 PM      PLOT BY: GARNICA, BRANDON      PLOT NAME:      PLOT SCALE: 1 IN:10 FT HORZ. / 1 IN:10 FT VERT.      WISDOT/CADD SHEET 49

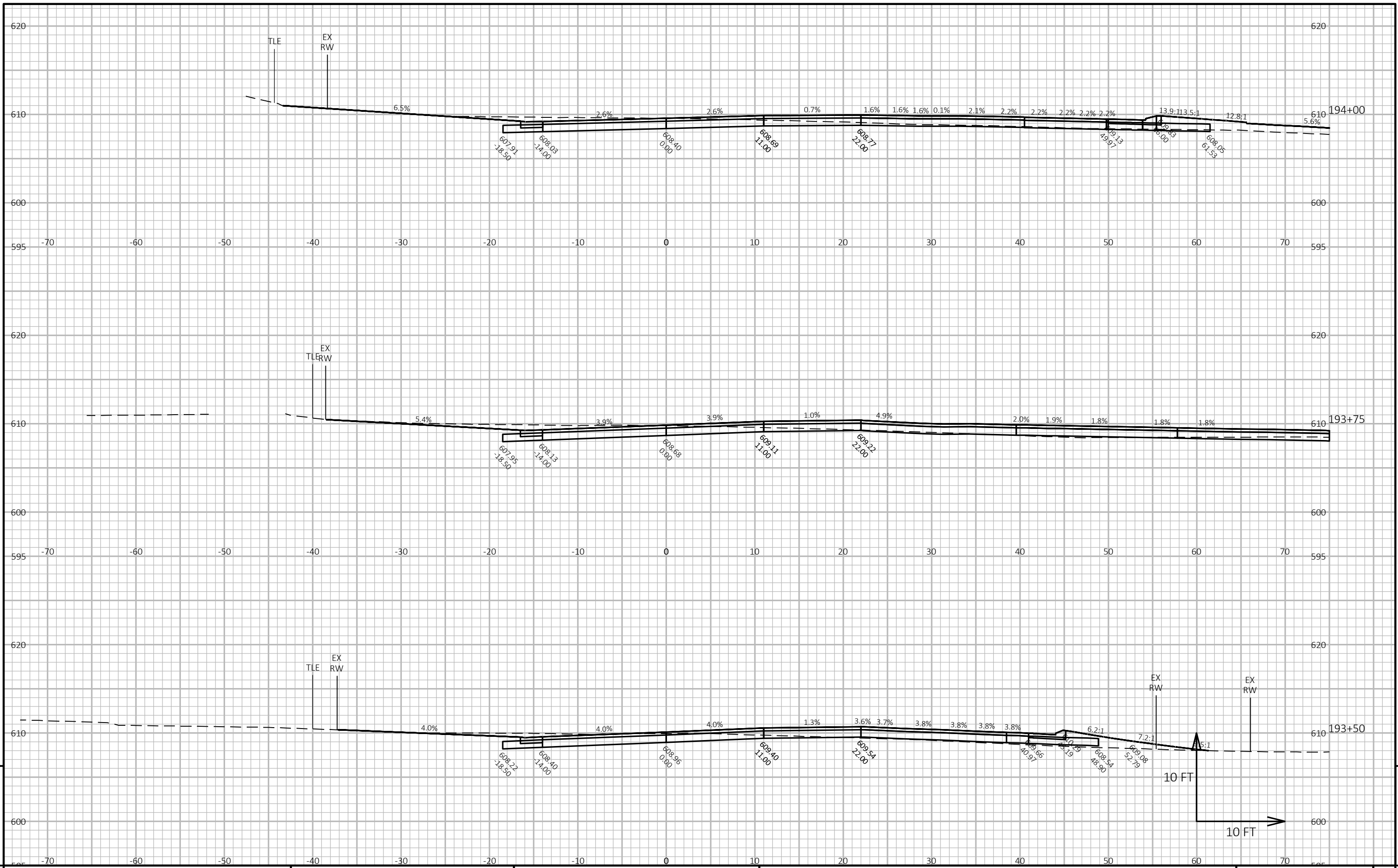

9

9

PROJECT NO: 4390-07-71	HWY: CTH C	COUNTY: KEWAUNEE	CROSS SECTIONS: URBAN	SHEET	E
------------------------	------------	------------------	-----------------------	-------	---

FILE NAME : I:\451450511 KEWAUNEE CTH C ROADWAY\C3D\SHEETSPLAN\090201-XS.DWG PLOT DATE : 1/9/2024 12:18 PM PLOT BY : GARNICA, BRANDON PLOT NAME : LAYOUT NAME - 090219-xs PLOT SCALE : 1 IN:10 FT HORZ. / 1 IN:10 FT VERT. WISDOT/CADD SHEET 49

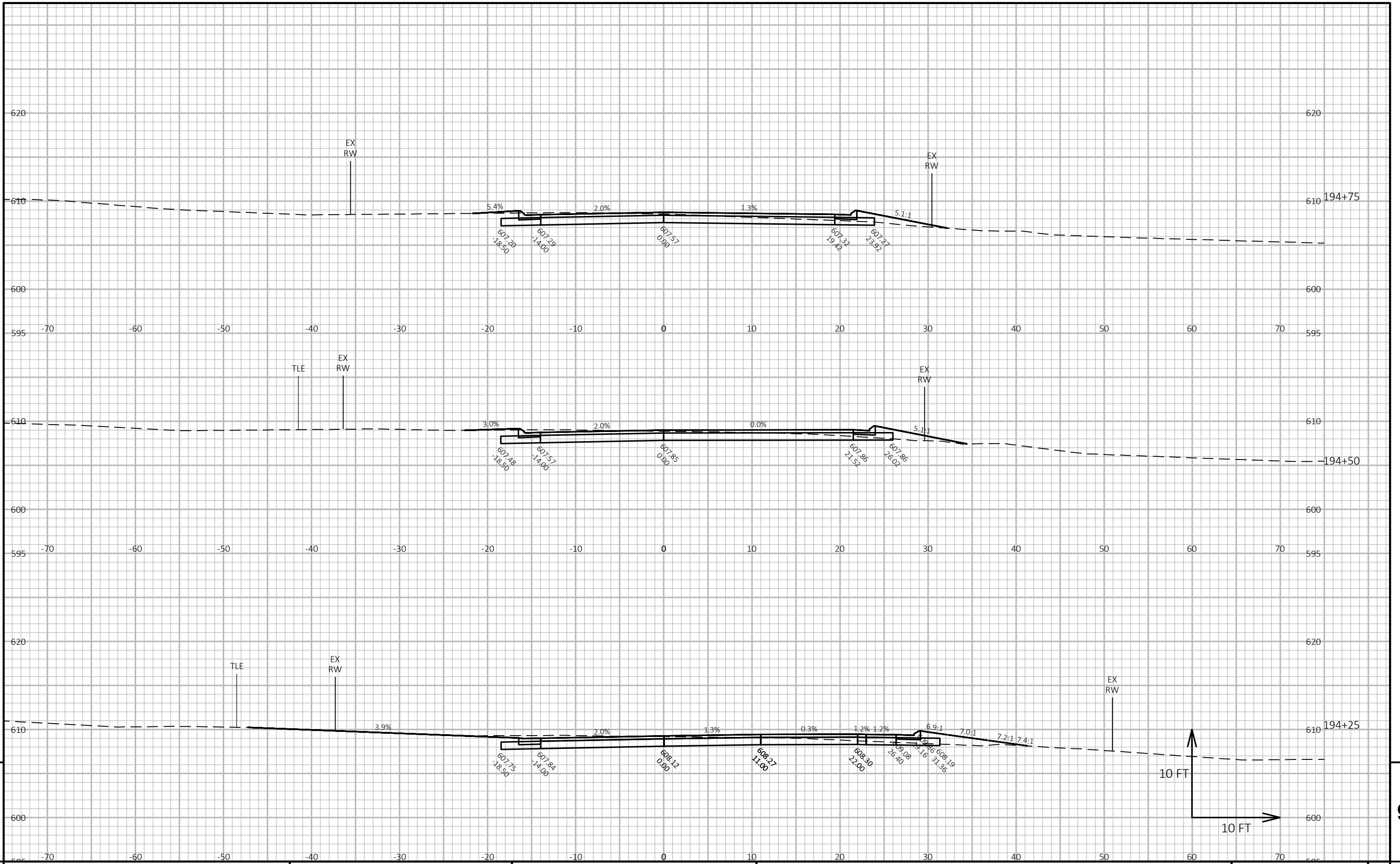

PROJECT NO: 4390-07-71      HWY: CTH C      COUNTY: KEWAUNEE      CROSS SECTIONS: URBAN      SHEET 9

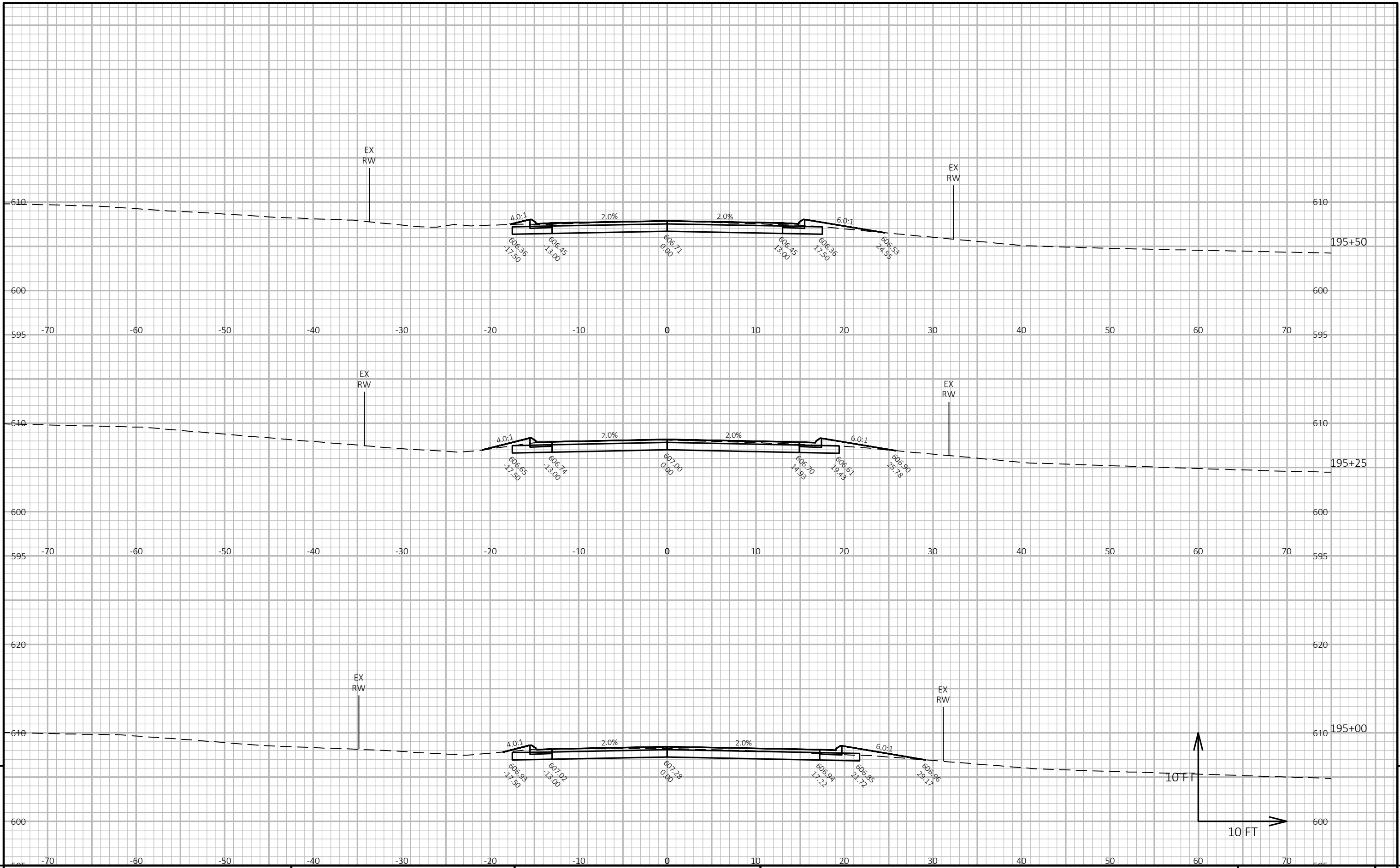

9

9

PROJECT NO: 4390-07-71      HWY: CTH C      COUNTY: KEWAUNEE      CROSS SECTIONS: URBAN      SHEET E

FILE NAME : I:\45\450511 KEWAUNEE CTH C ROADWAY\C3D\SHEETSPLAN\090201-XS.DWG      PLOT DATE : 1/9/2024 12:18 PM      PLOT BY : GARNICA, BRANDON      PLOT NAME :      PLOT SCALE : 1 IN:10 FT HORZ. / 1 IN:10 FT VERT.      WISDOT/CADD SHEET 49

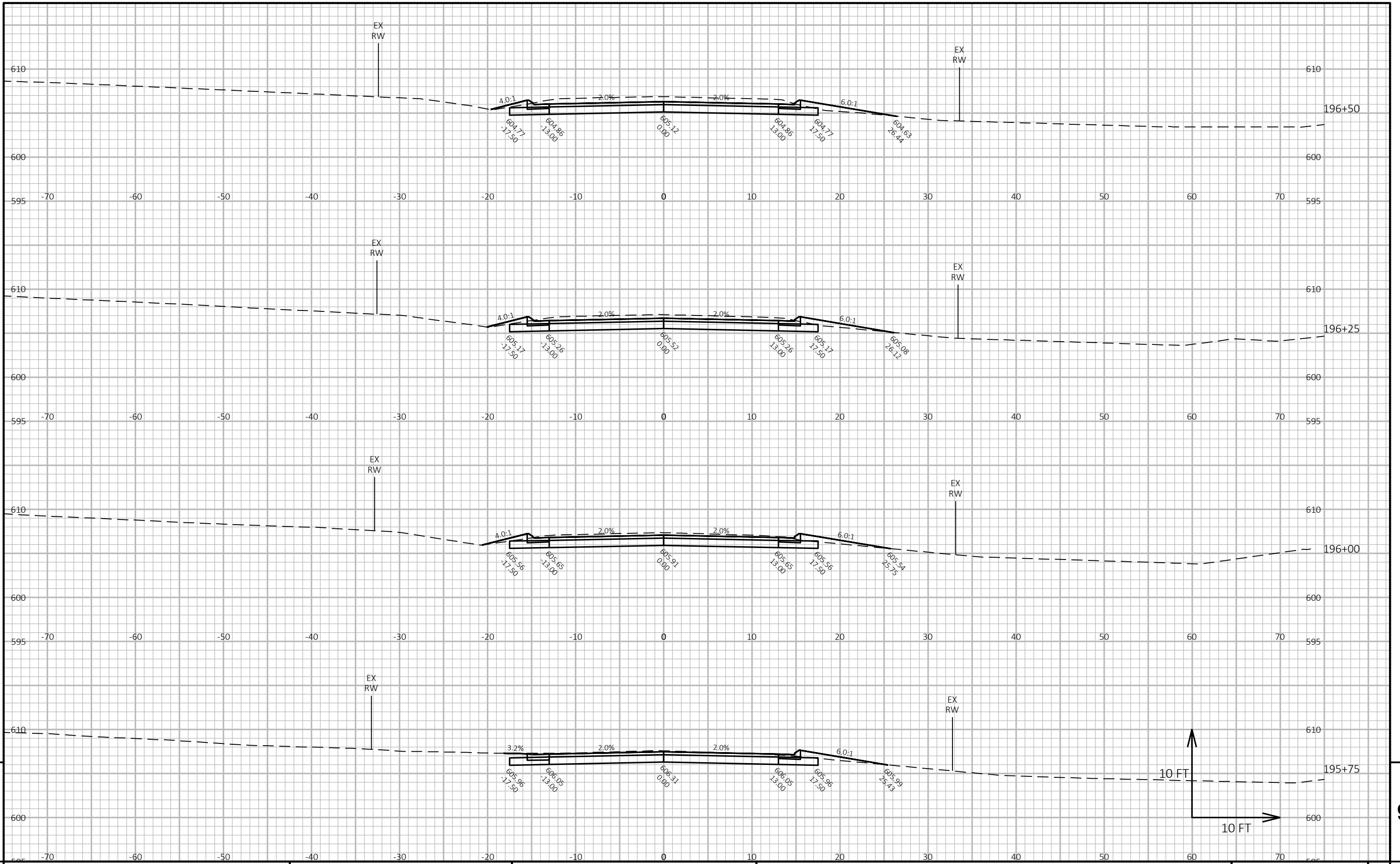

9

9

PROJECT NO: 4390-07-71      HWY: CTH C      COUNTY: KEWAUNEE      CROSS SECTIONS: URBAN      SHEET      E

FILE NAME : I:\45\450511 KEWAUNEE CTH C ROADWAY\C3D\SHEETSPLAN\090201-XS.DWG      PLOT DATE : 1/9/2024 12:18 PM      PLOT BY : GARNICA, BRANDON      PLOT NAME :      PLOT SCALE : 1 IN:10 FT HORZ. / 1 IN:10 FT VERT.      WISDOT/CADD SHEET 49

LAYOUT NAME - 090222-xs



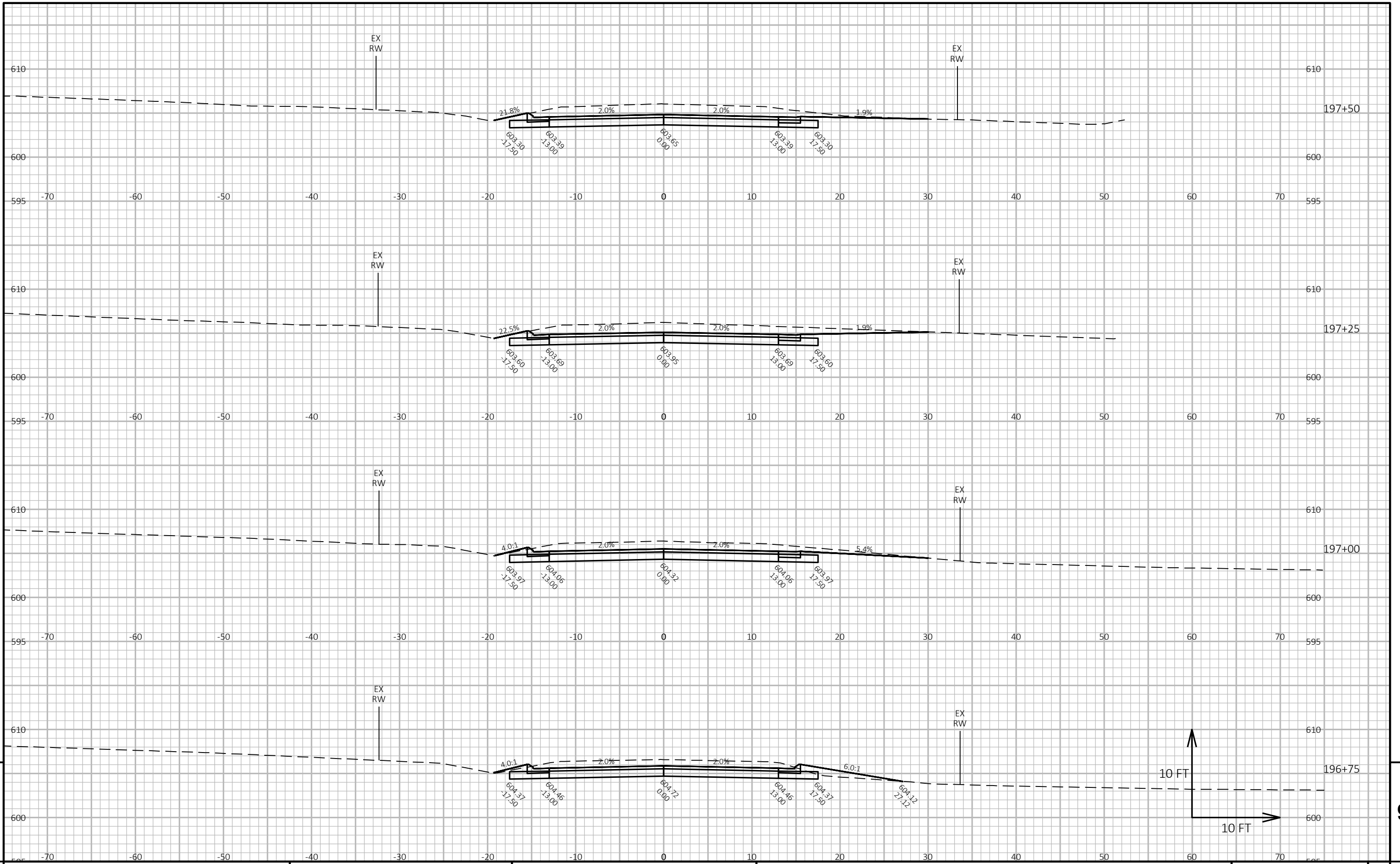

PROJECT NO: 4390-07-71

HWY: CTH C

COUNTY: KEWAUNEE

CROSS SECTIONS: URBAN

SHEET

E

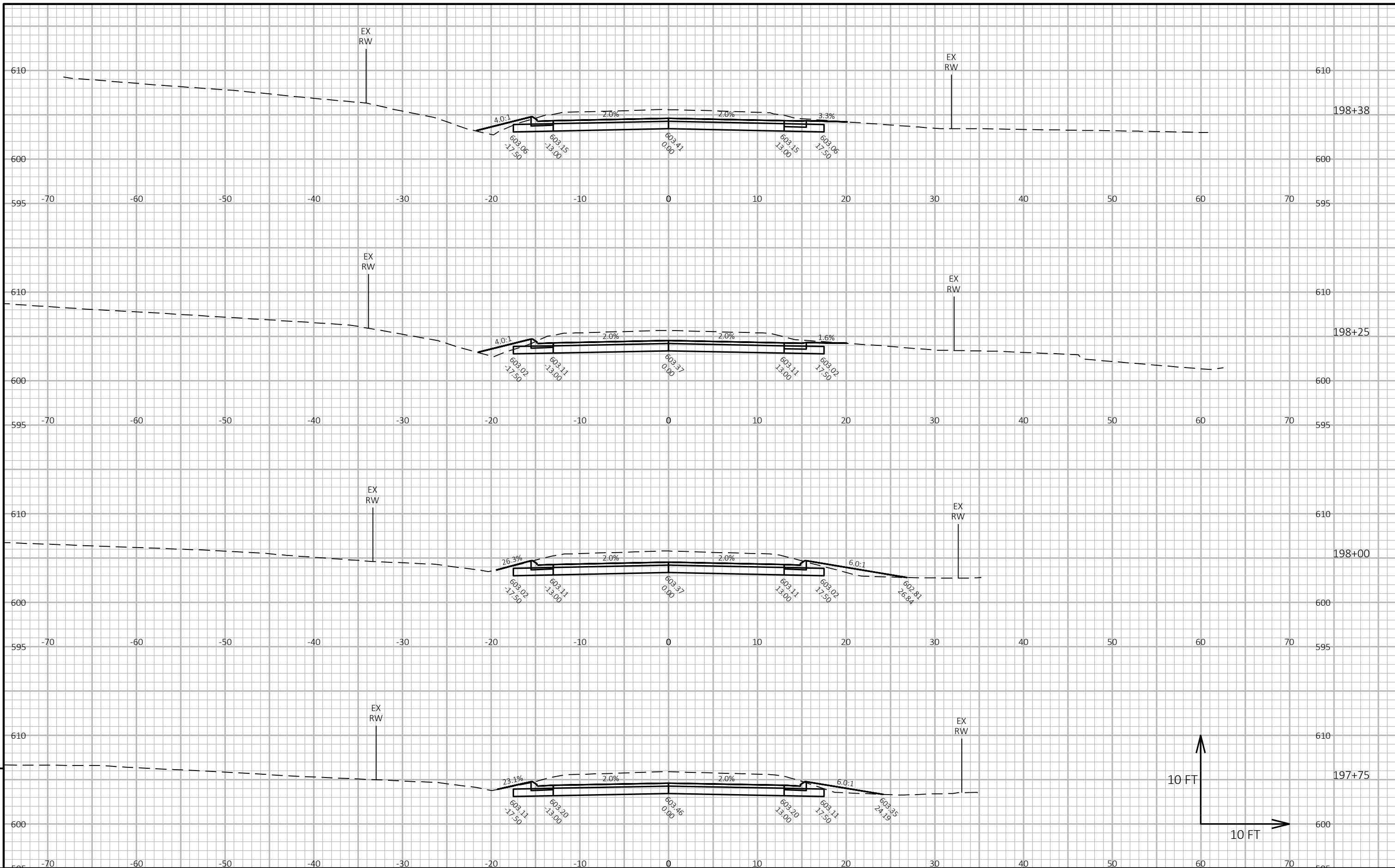

9

9

PROJECT NO: 4390-07-71      HWY: CTH C      COUNTY: KEWAUNEE      CROSS SECTIONS: URBAN      SHEET E

FILE NAME: I:\45\450511 KEWAUNEE CTH C ROADWAY\C3D\SHEETSPLAN\090201-XS.DWG      PLOT DATE: 1/9/2024 12:18 PM      PLOT BY: GARNICA, BRANDON      PLOT NAME:      PLOT SCALE: 1 IN:10 FT HORZ. / 1 IN:10 FT VERT.      WISDOT/CADD SHEET 49

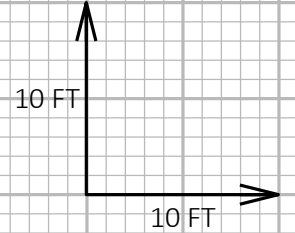

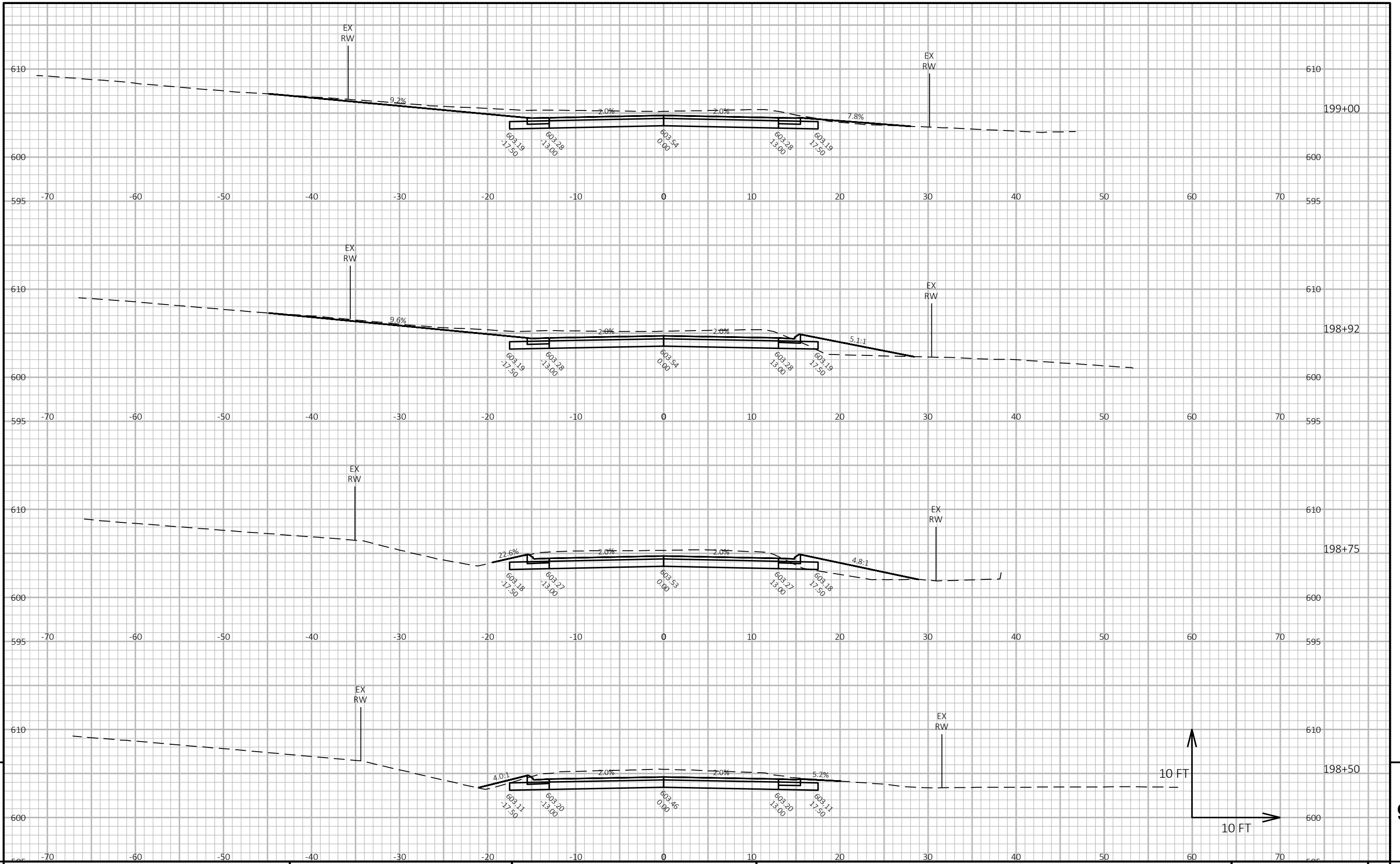

9

9

PROJECT NO: 4390-07-71      HWY: CTH C      COUNTY: KEWAUNEE      CROSS SECTIONS: URBAN      SHEET      E

FILE NAME : I:\451450511 KEWAUNEE CTH C ROADWAY\C3D\SHEETSPLAN\090201-XS.DWG      PLOT DATE : 1/9/2024 12:18 PM      PLOT BY : GARNICA, BRANDON      PLOT NAME :      PLOT SCALE : 1 IN:10 FT HORZ. / 1 IN:10 FT VERT.      WISDOT/CADD SHEET 49

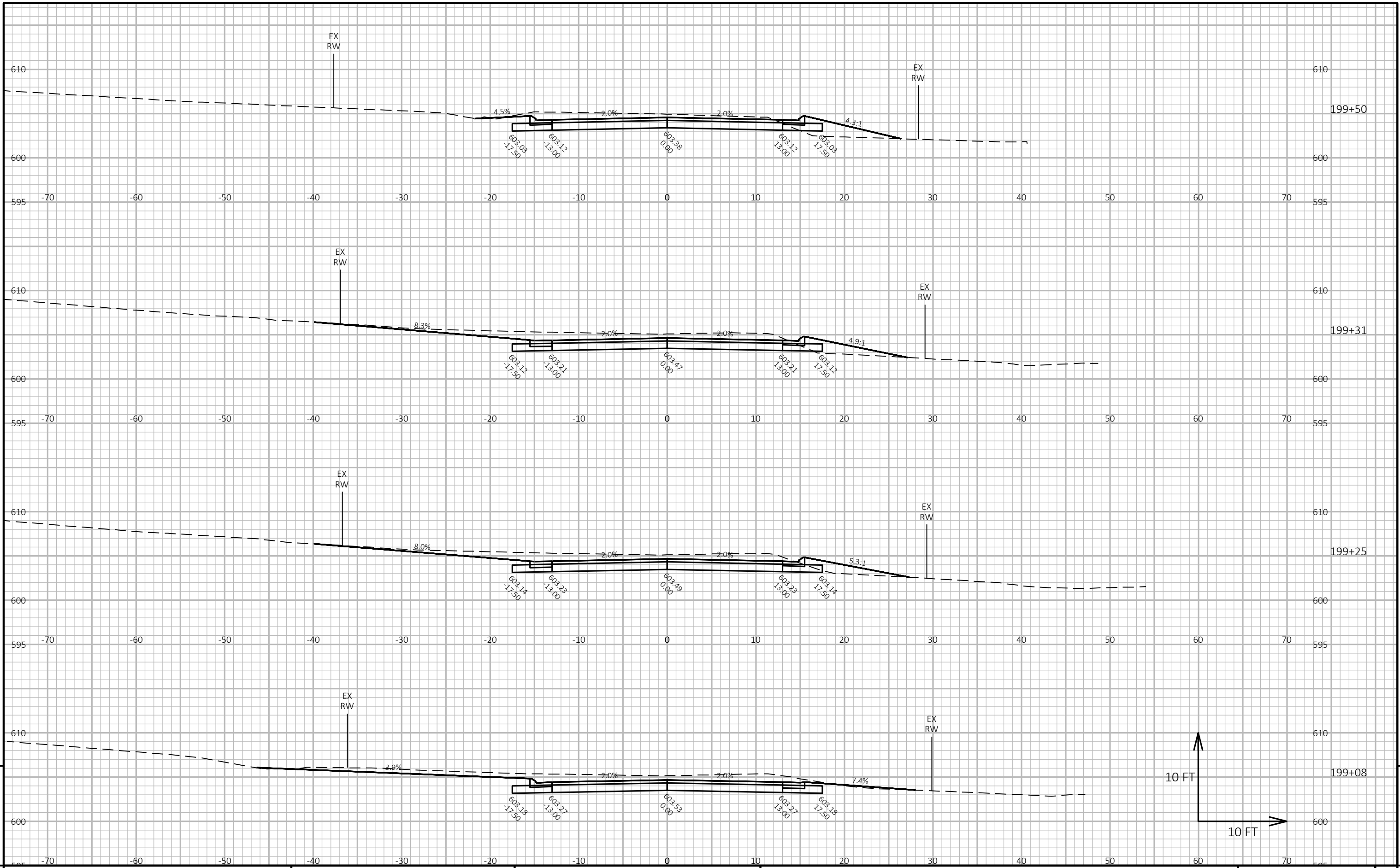

9

9

PROJECT NO: 4390-07-71	HWY: CTH C	COUNTY: KEWAUNEE	CROSS SECTIONS: URBAN	SHEET	E
------------------------	------------	------------------	-----------------------	-------	---

FILE NAME : I:\45\450511 KEWAUNEE CTH C ROADWAY\C3D\SHEETSPLAN\090201-XS.DWG PLOT DATE : 1/9/2024 12:18 PM PLOT BY : GARNICA, BRANDON PLOT NAME : SHEET SCALE : 1 IN:10 FT HORZ. / 1 IN:10 FT VERT. WISDOT/CADD SHEET 49

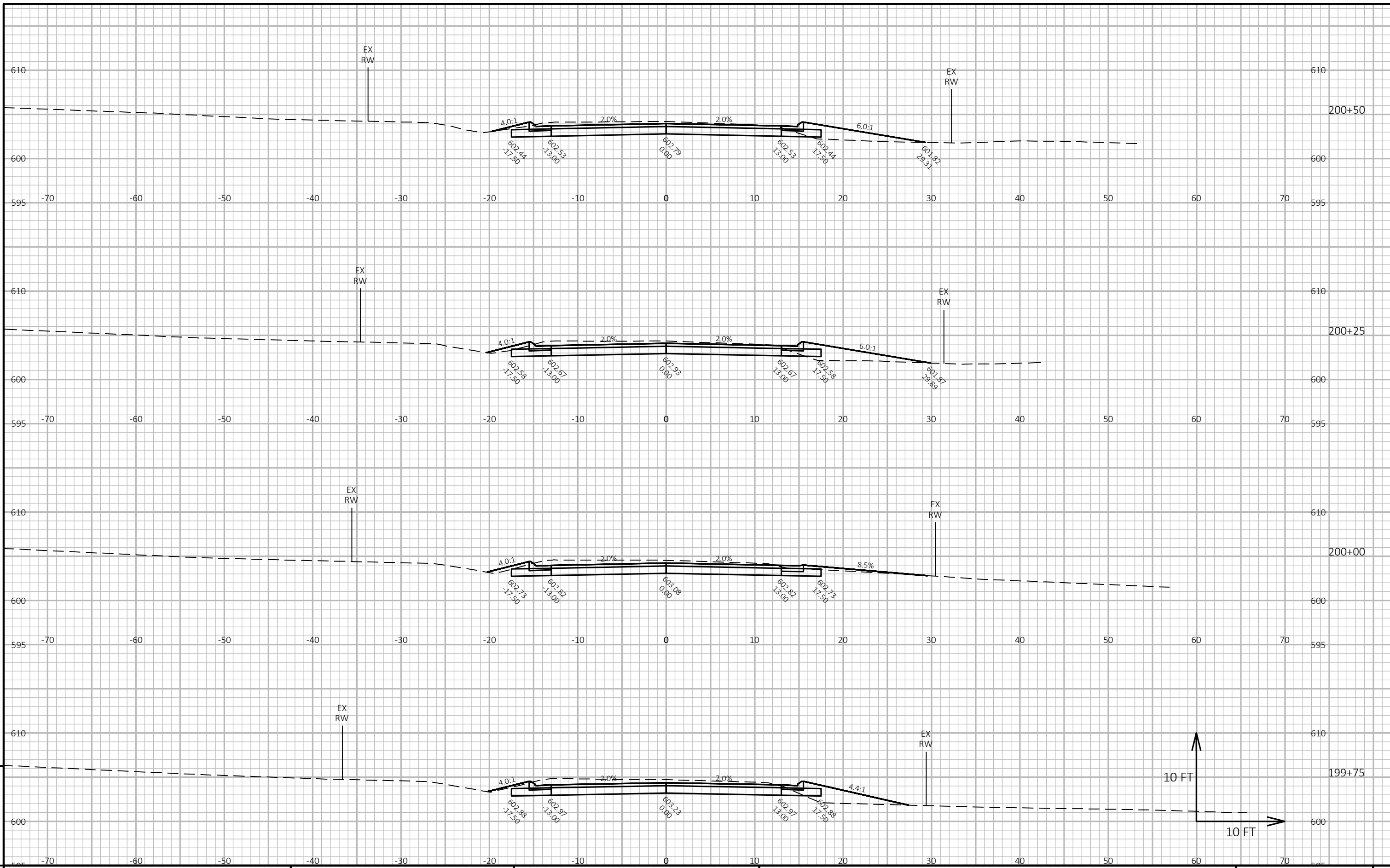

PROJECT NO: 4390-07-71	HWY: CTH C	COUNTY: KEWAUNEE	CROSS SECTIONS: URBAN	SHEET
------------------------	------------	------------------	-----------------------	-------

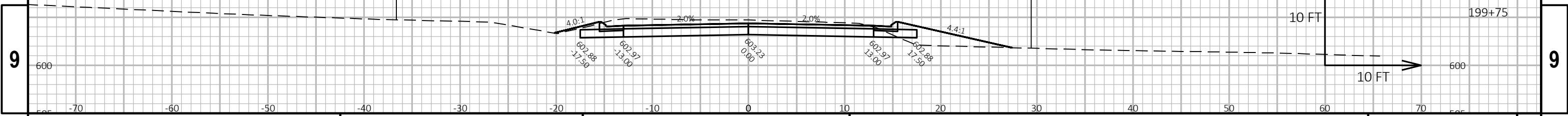

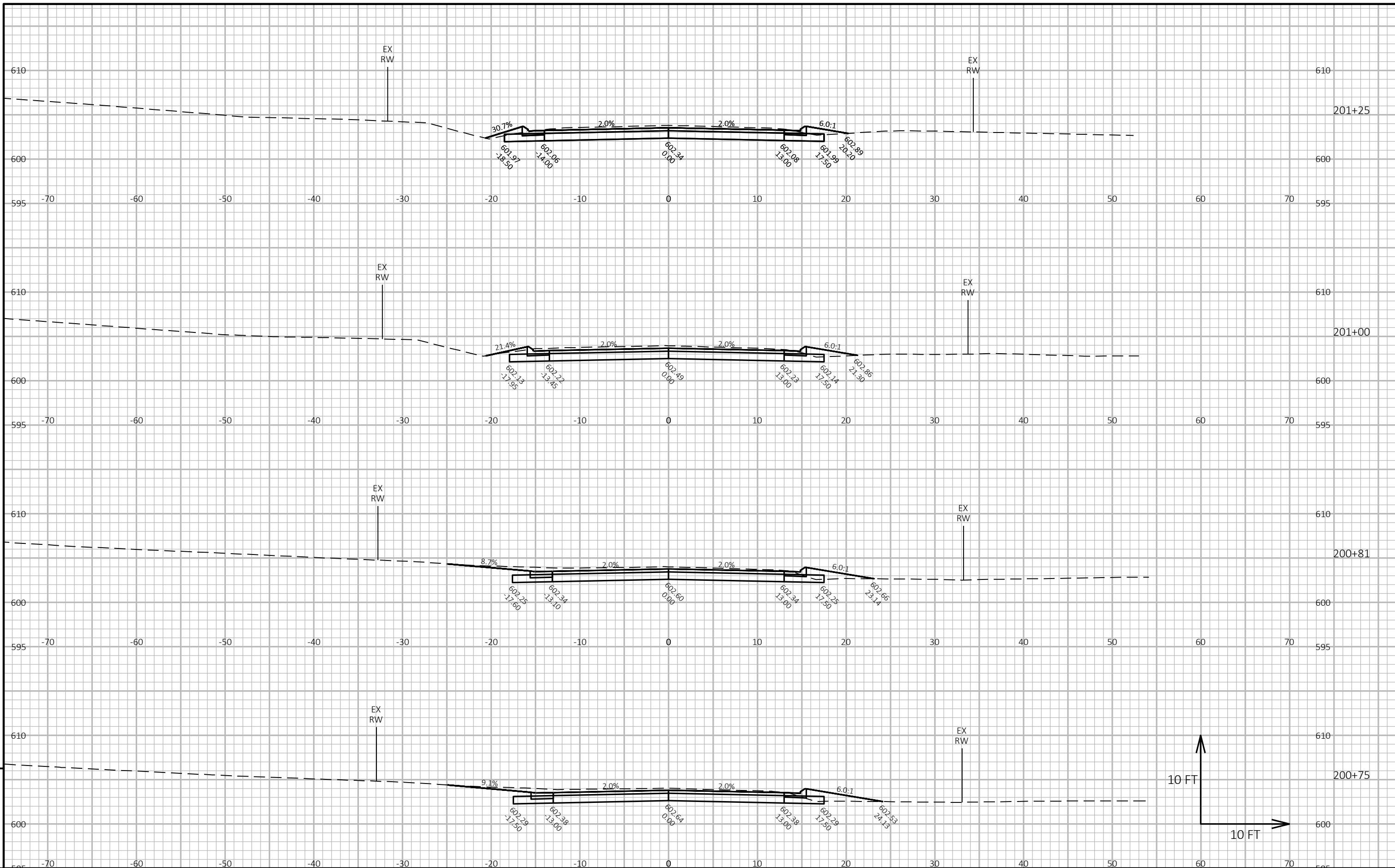

PROJECT NO: 4390-07-71	HWY: CTH C	COUNTY: KEWAUNEE	CROSS SECTIONS: URBAN	SHEET E
------------------------	------------	------------------	-----------------------	---------

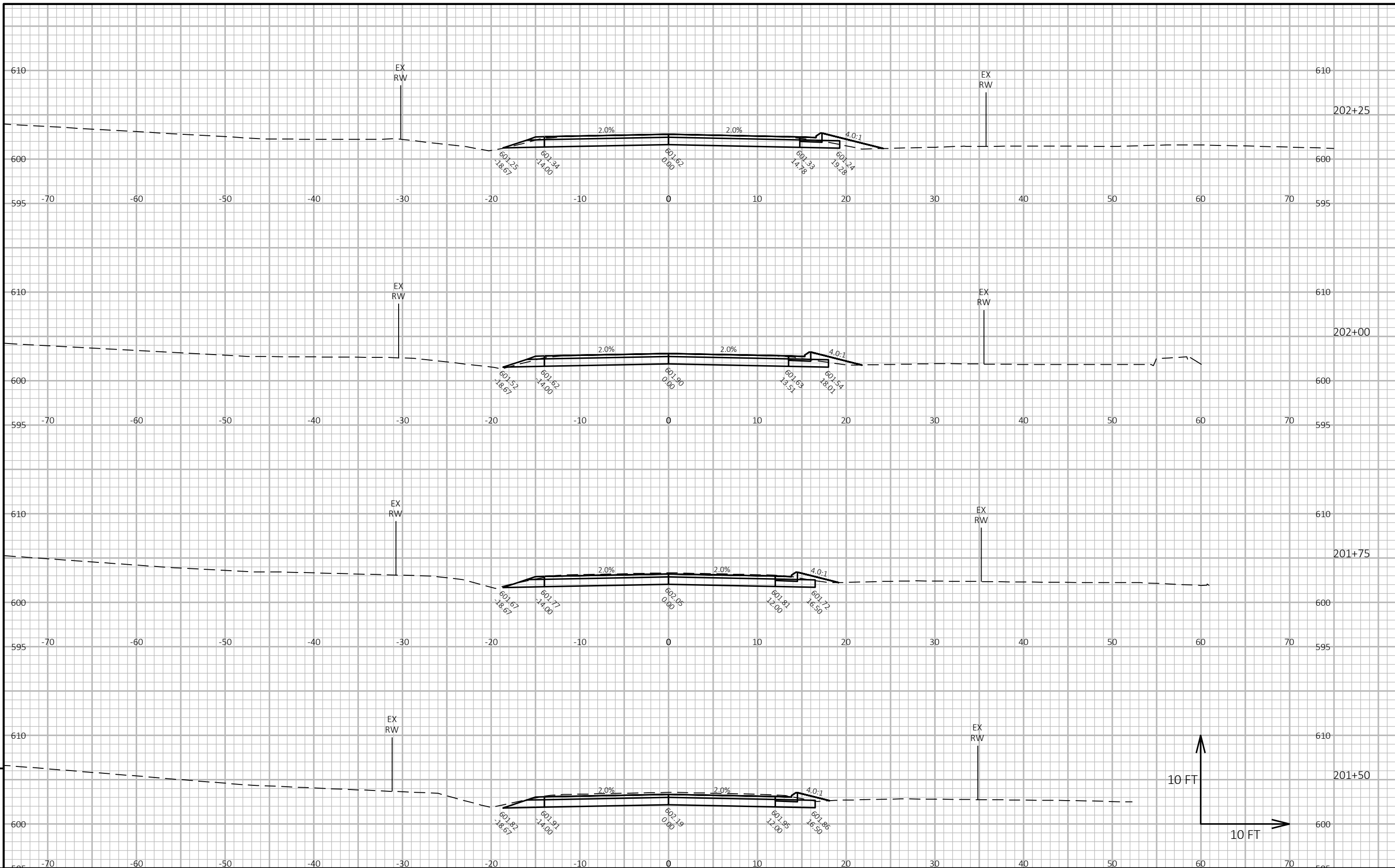

PROJECT NO: 4390-07-71      HWY: CTH C      COUNTY: KEWAUNEE      CROSS SECTIONS: URBAN      SHEET 9

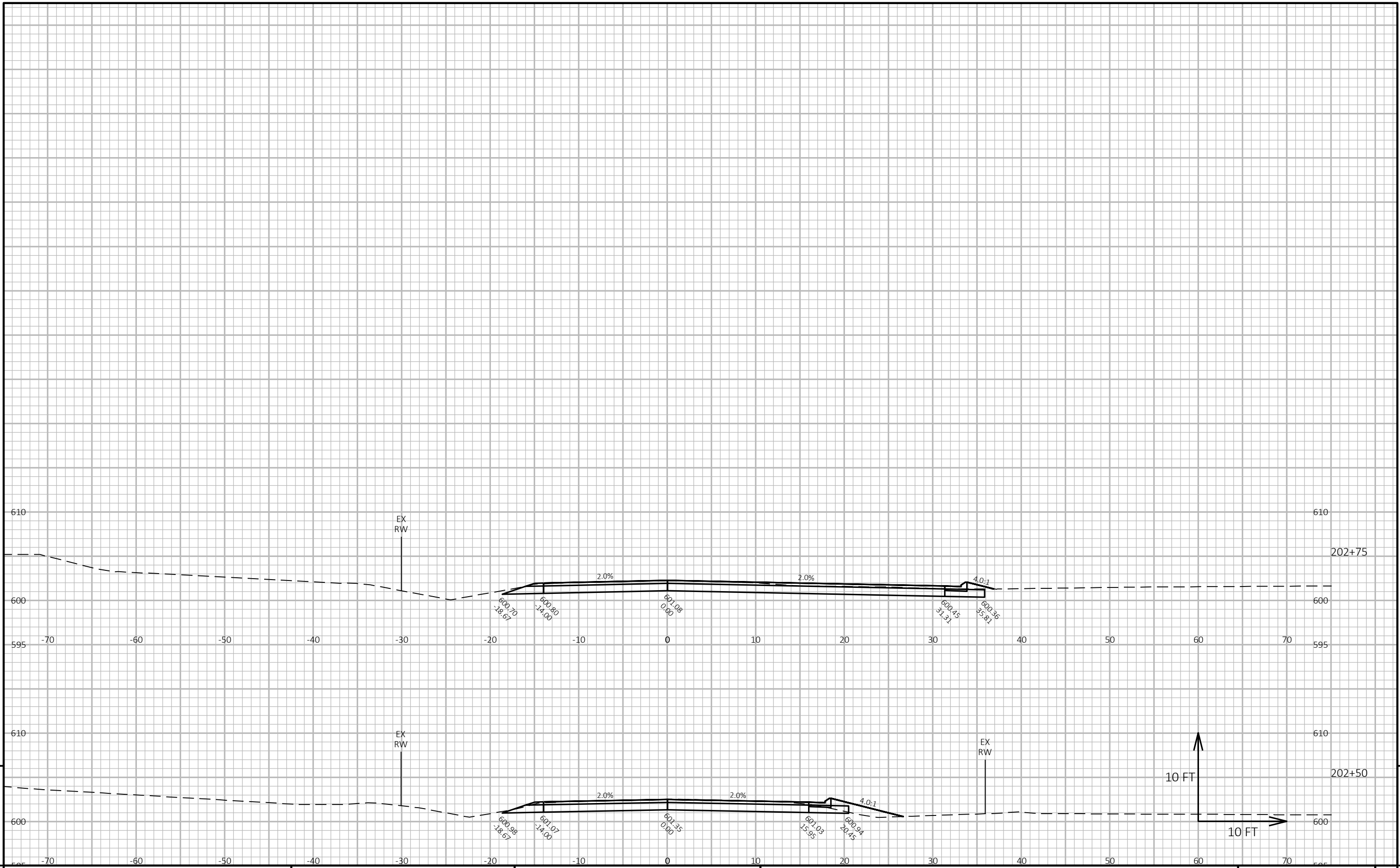

PROJECT NO: 4390-07-71

HWY: CTH C

COUNTY: KEWAUNEE

CROSS SECTIONS: URBAN

SHEET

E



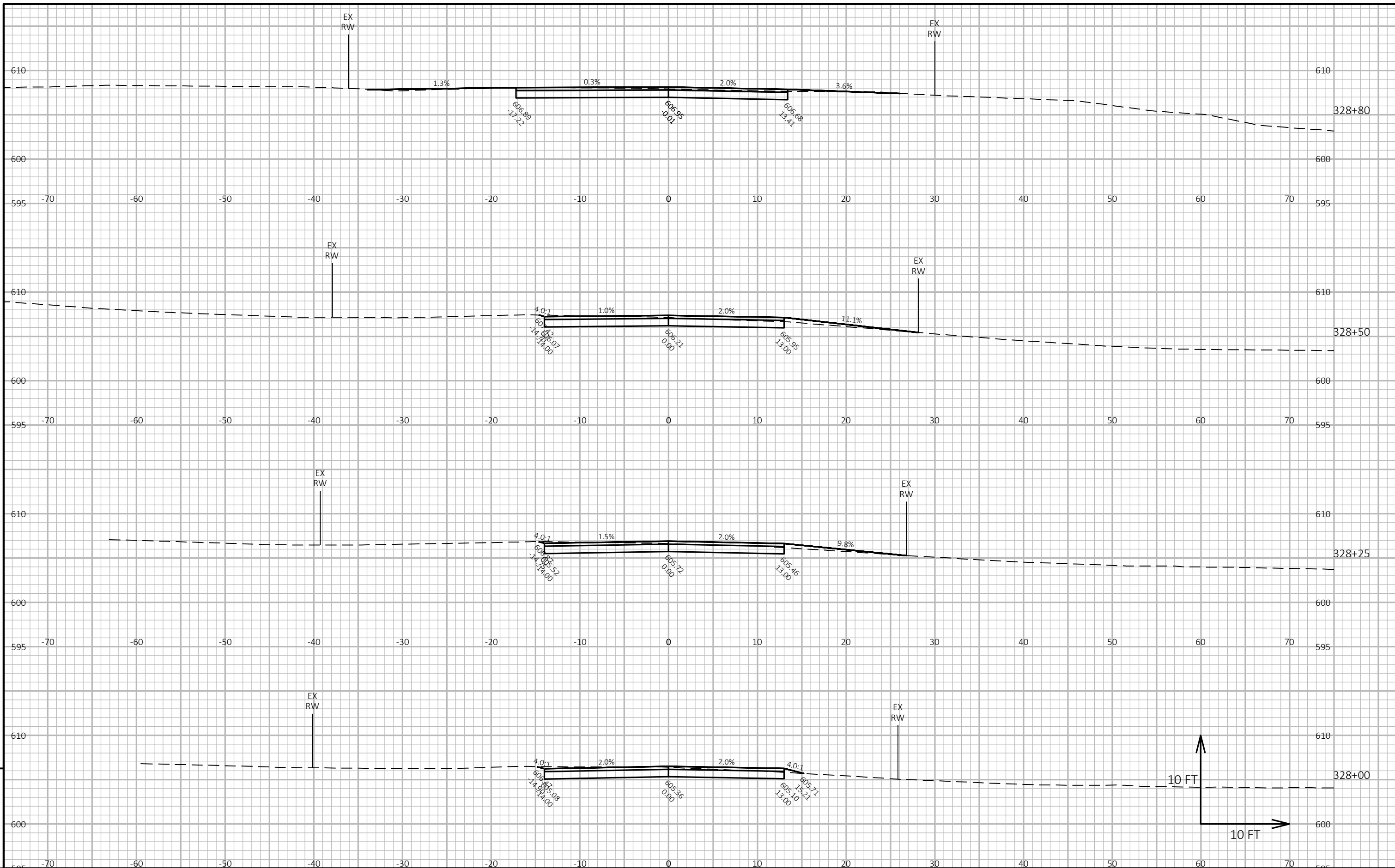

PROJECT NO: 4390-07-71

HWY: CTH C

COUNTY: KEWAUNEE

CROSS SECTIONS: CTH F

SHEET

E

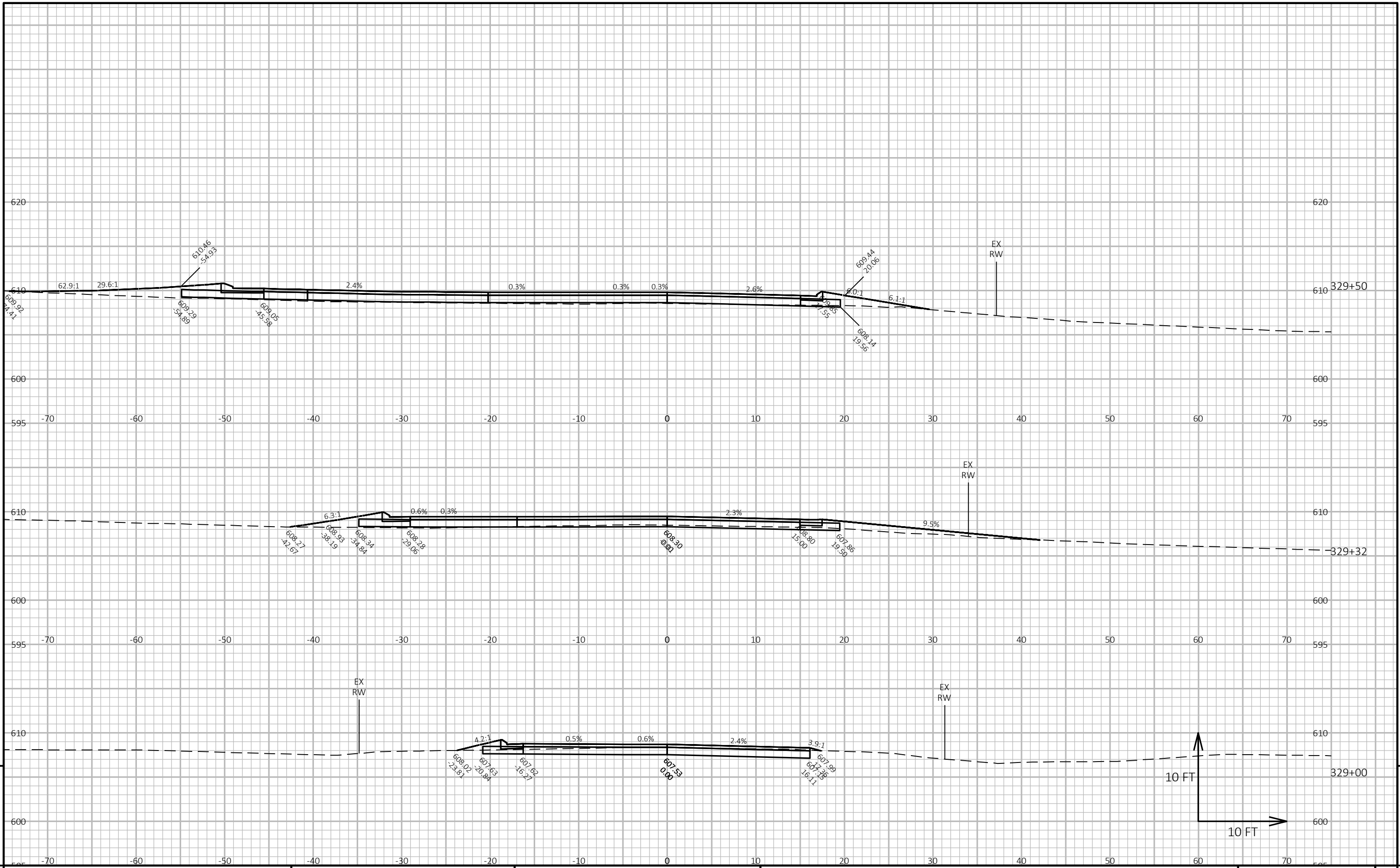

9

9

PROJECT NO: 4390-07-71      HWY: CTH C      COUNTY: KEWAUNEE      CROSS SECTIONS: CTH F      SHEET      E

FILE NAME : I:\45\450511 KEWAUNEE CTH C ROADWAY\C3D\SHEETSPLAN\090201-XS.DWG      PLOT DATE : 1/9/2024 12:19 PM      PLOT BY : GARNICA, BRANDON      PLOT NAME :      PLOT SCALE : 1 IN:10 FT HORZ. / 1 IN:10 FT VERT.      WISDOT/CADD SHEET 49

LAYOUT NAME - 090260-xs

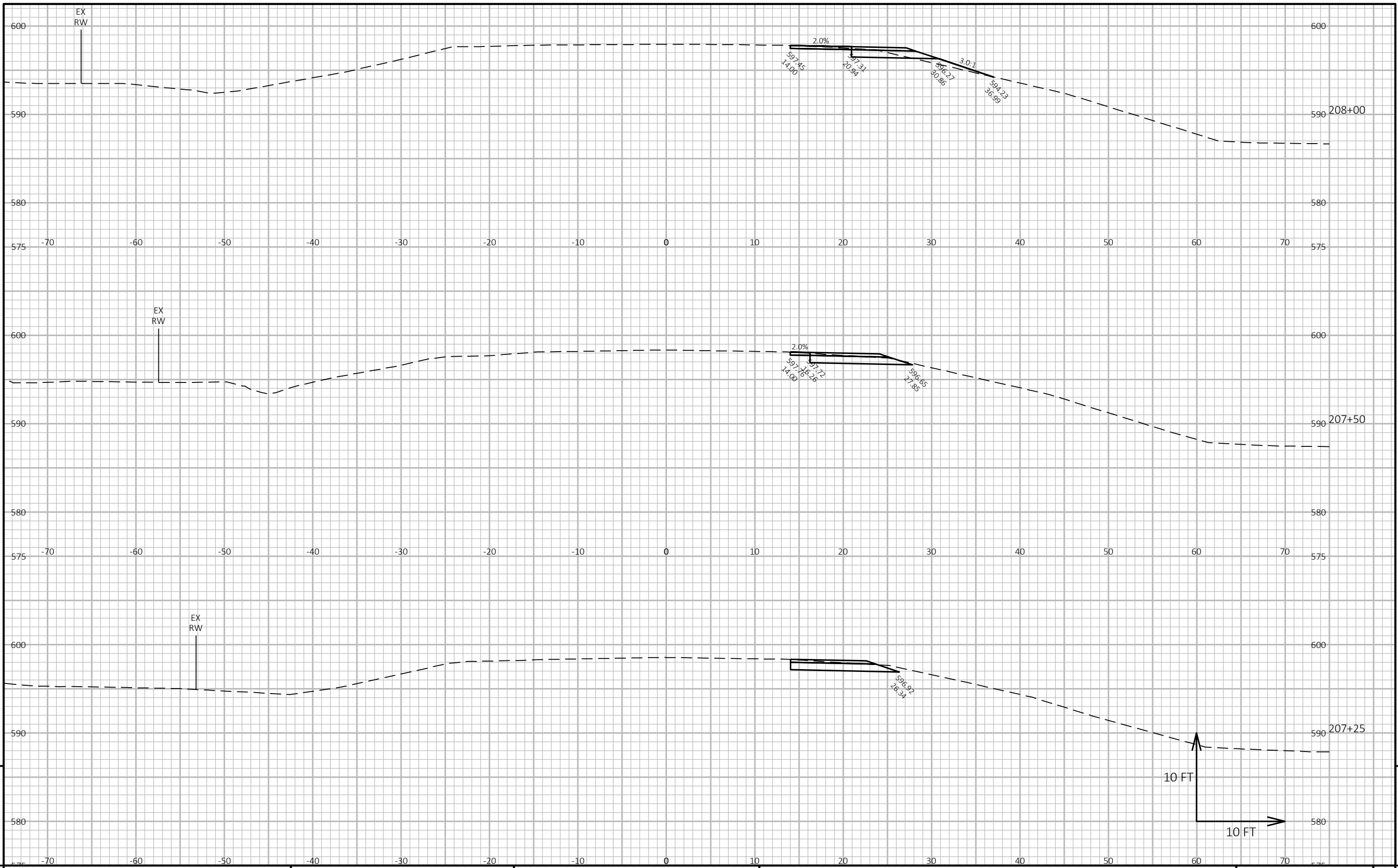

PROJECT NO: 4390-07-71

HWY: CTH C

COUNTY: KEWAUNEE

CROSS SECTIONS: MIDDLE GUARDRAIL

SHEET

E

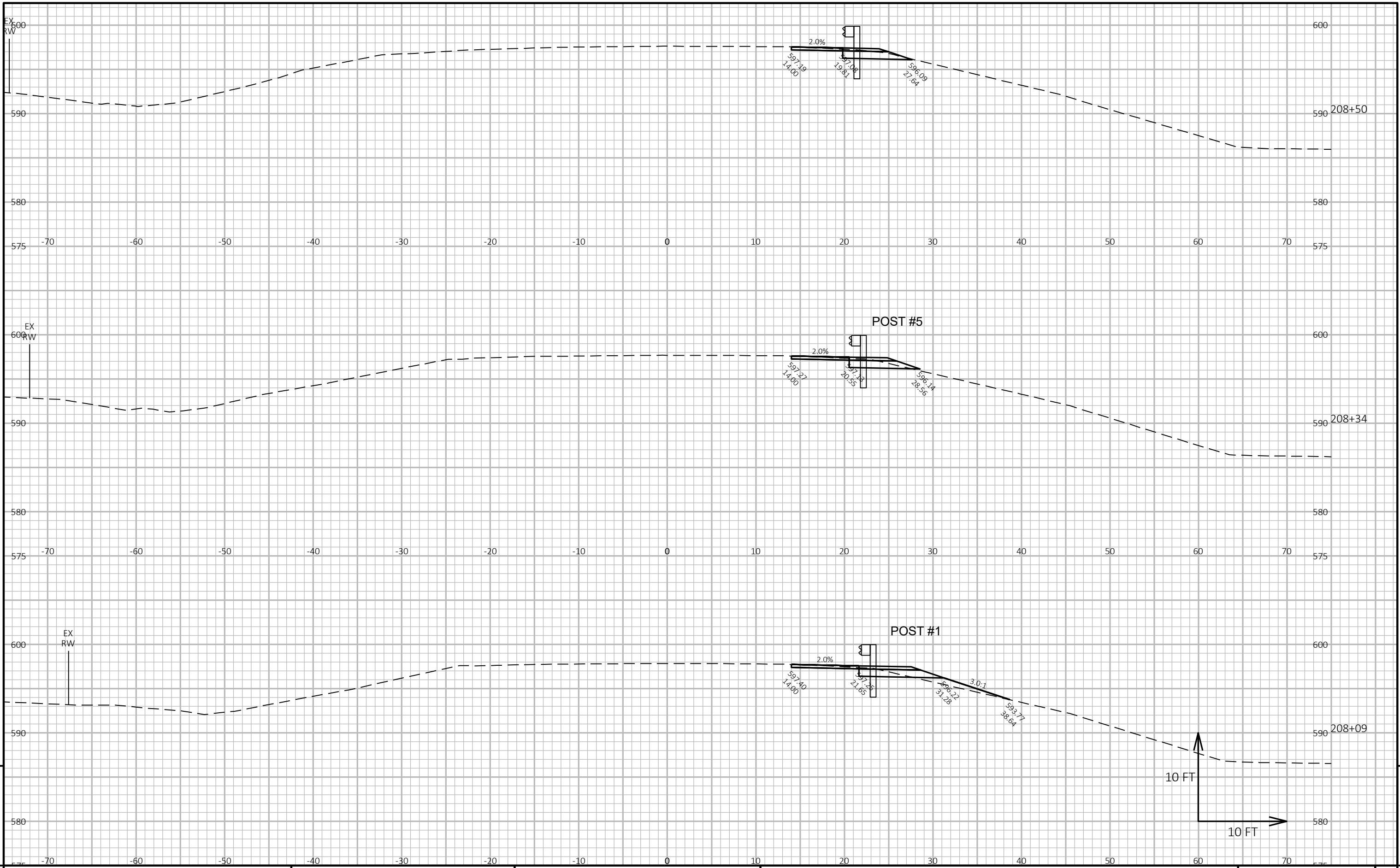

9

9

PROJECT NO: 4390-07-71      HWY: CTH C      COUNTY: KEWAUNEE      CROSS SECTIONS: MIDDLE GUARDRAIL      SHEET E

FILE NAME : I:\451450511 KEWAUNEE CTH C ROADWAY\C3D\SHEETSPLAN\090201-XS.DWG      PLOT DATE : 1/9/2024 12:19 PM      PLOT BY : GARNICA, BRANDON      PLOT NAME :      PLOT SCALE : 1 IN:10 FT HORZ. / 1 IN:10 FT VERT.      WISDOT/CADD SHEET 49

LAYOUT NAME - 090232-xs

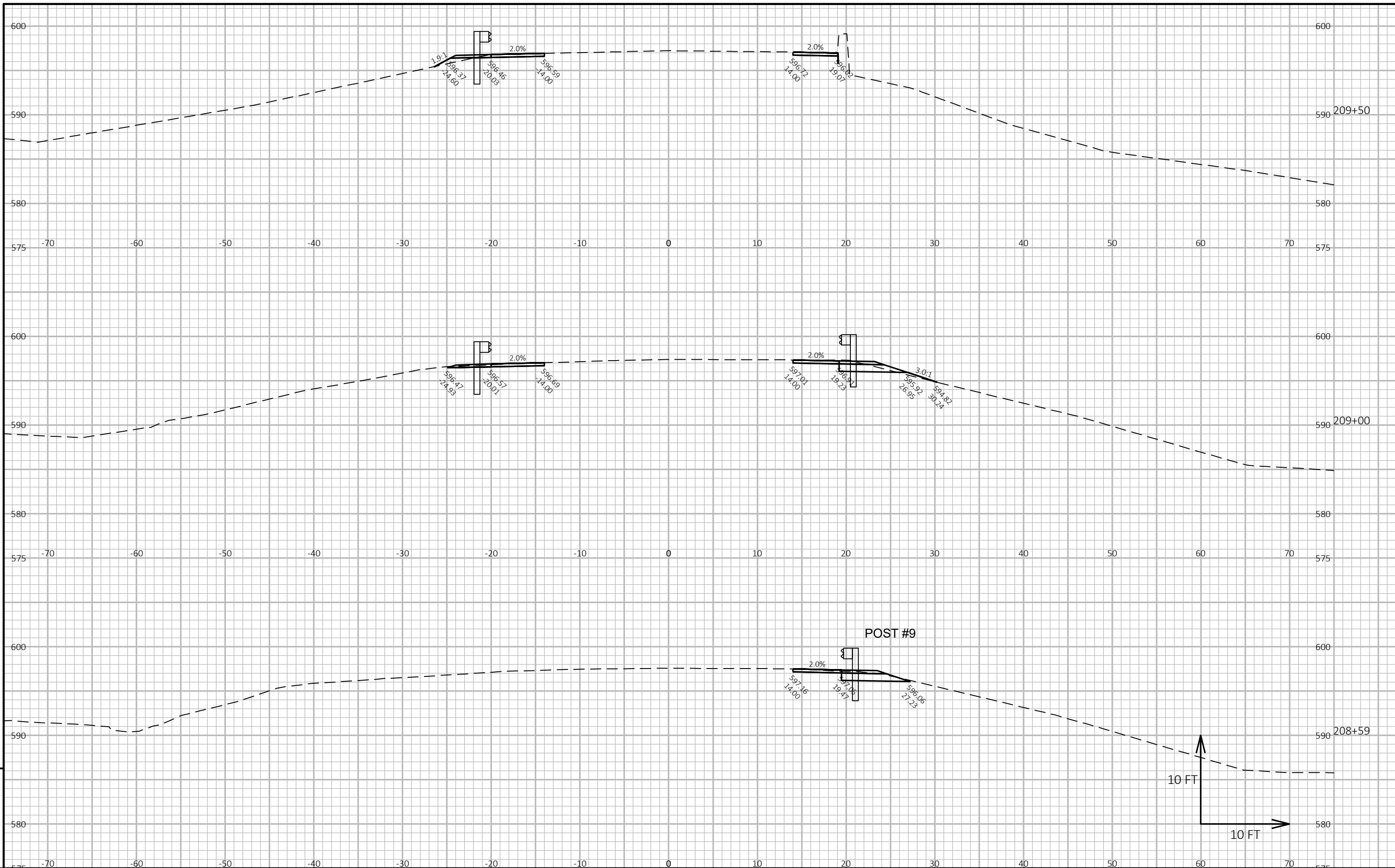

9

9

PROJECT NO: 4390-07-71	HWY: CTH C	COUNTY: KEWAUNEE	CROSS SECTIONS: MIDDLE GUARDRAIL	SHEET	E
------------------------	------------	------------------	----------------------------------	-------	---

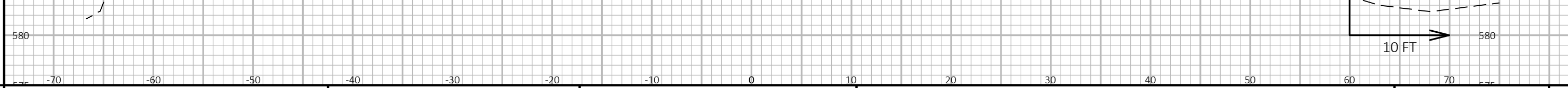
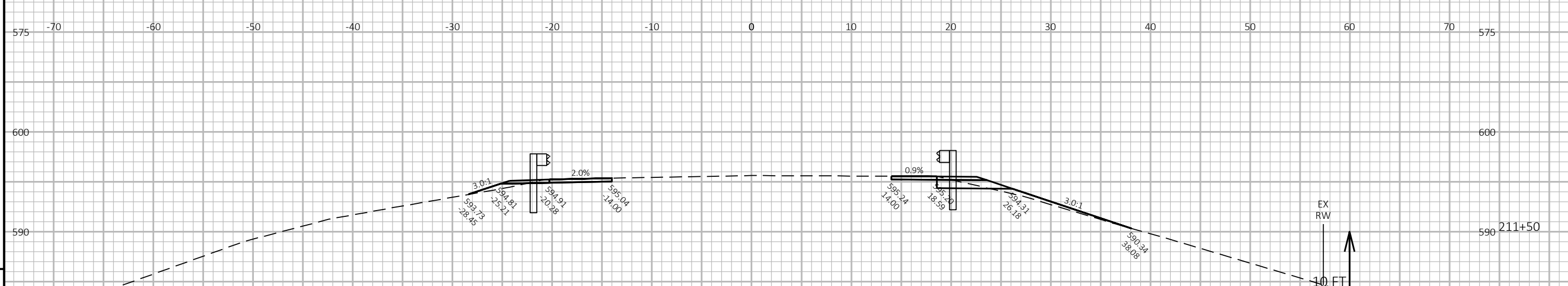
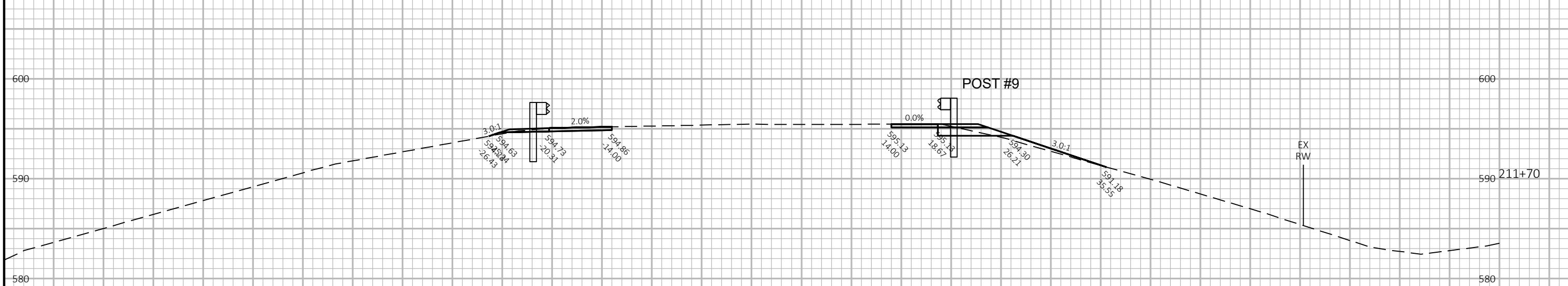
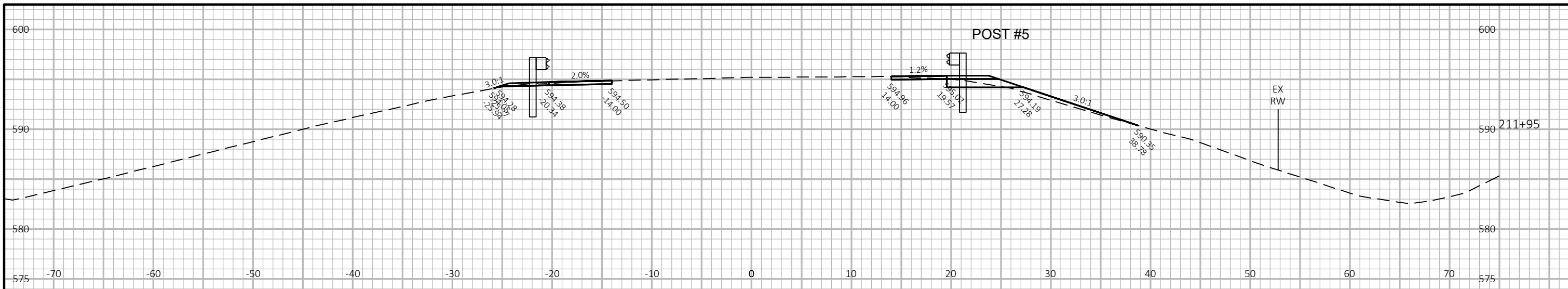

PROJECT NO: 4390-07-71      HWY: CTH C      COUNTY: KEWAUNEE      CROSS SECTIONS: MIDDLE GUARDRAIL      SHEET      E

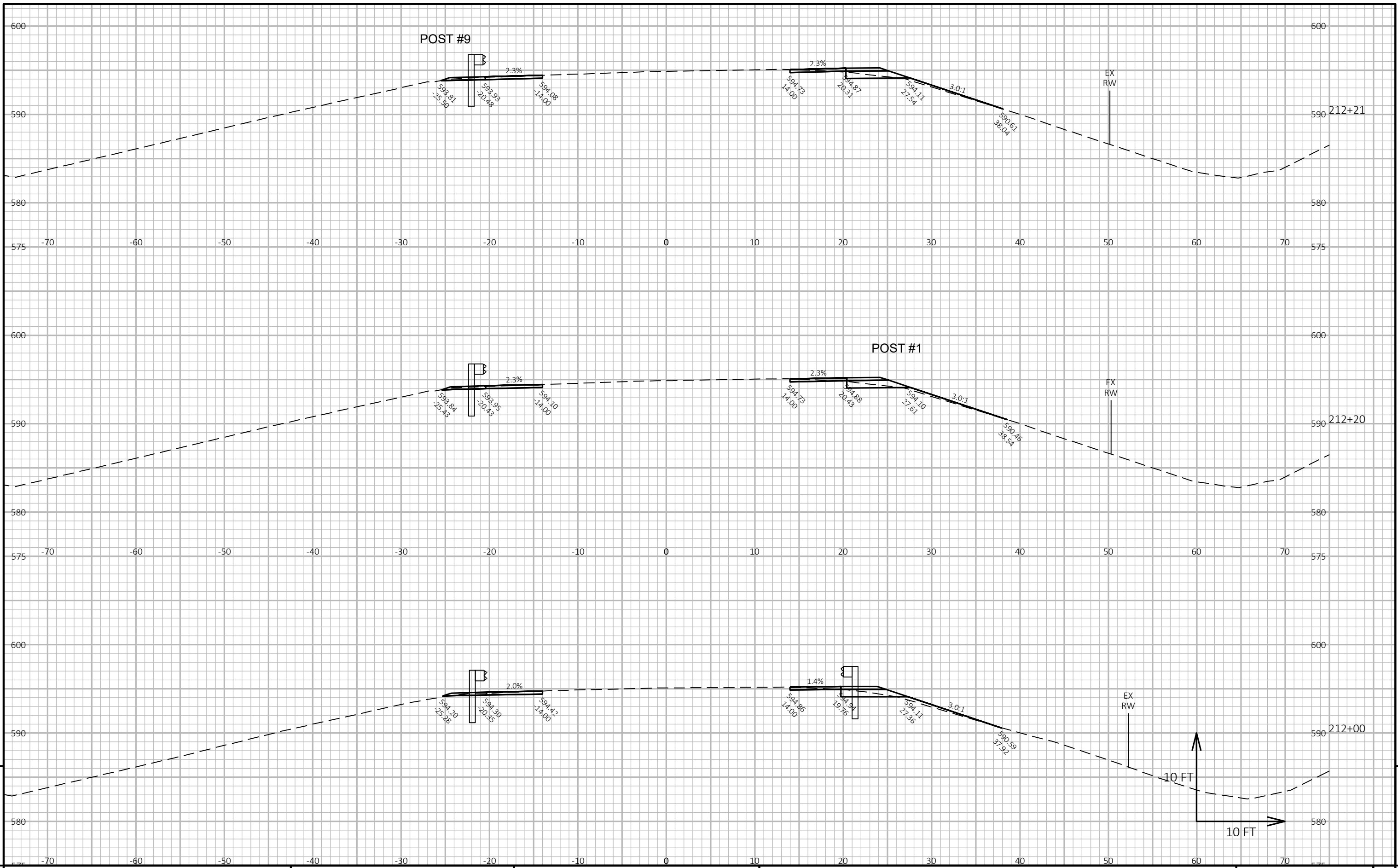

PROJECT NO: 4390-07-71      HWY: CTH C      COUNTY: KEWAUNEE      CROSS SECTIONS: MIDDLE GUARDRAIL      SHEET      E

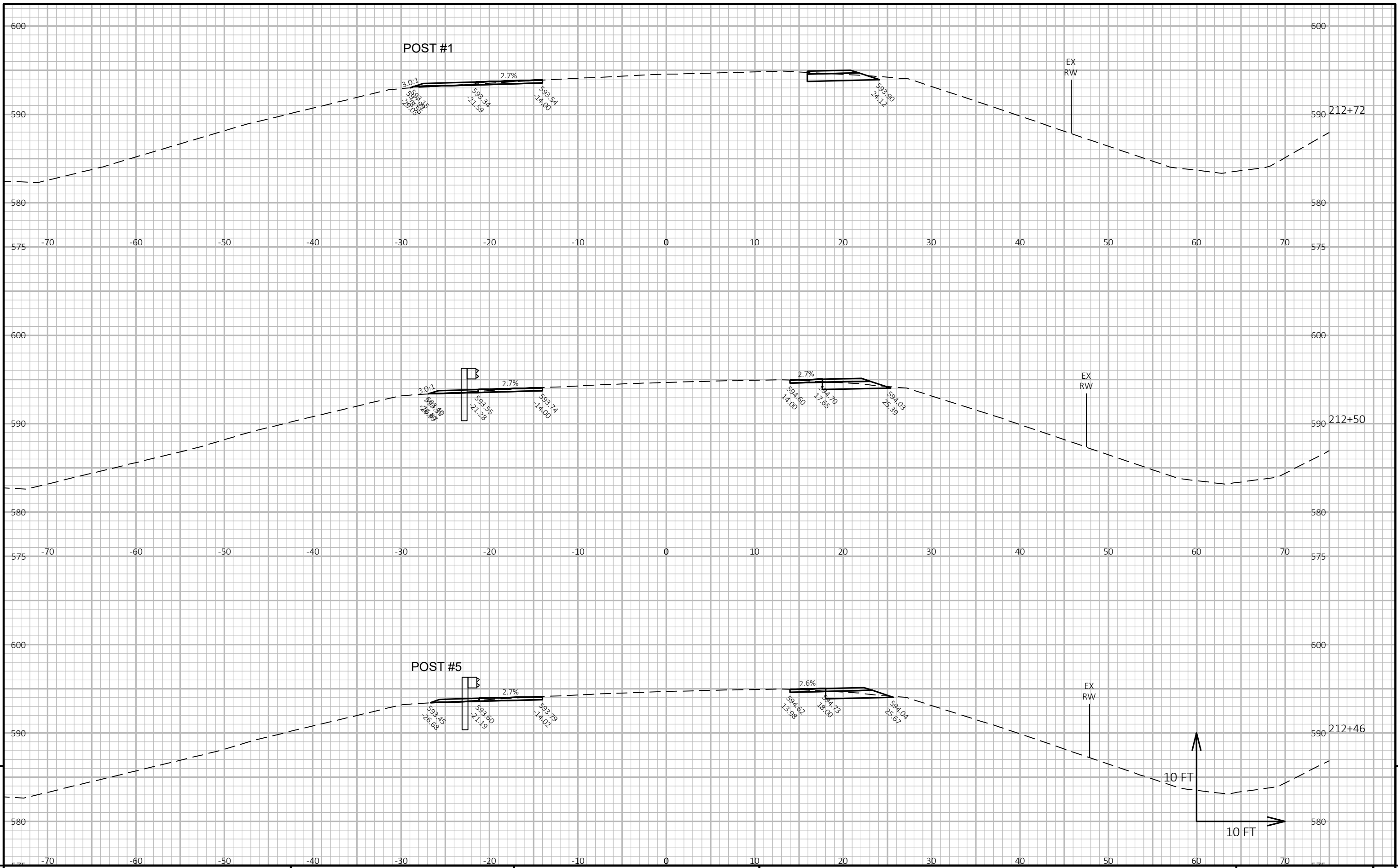

PROJECT NO: 4390-07-71	HWY: CTH C	COUNTY: KEWAUNEE	CROSS SECTIONS: MIDDLE GUARDRAIL	SHEET	E
------------------------	------------	------------------	----------------------------------	-------	---



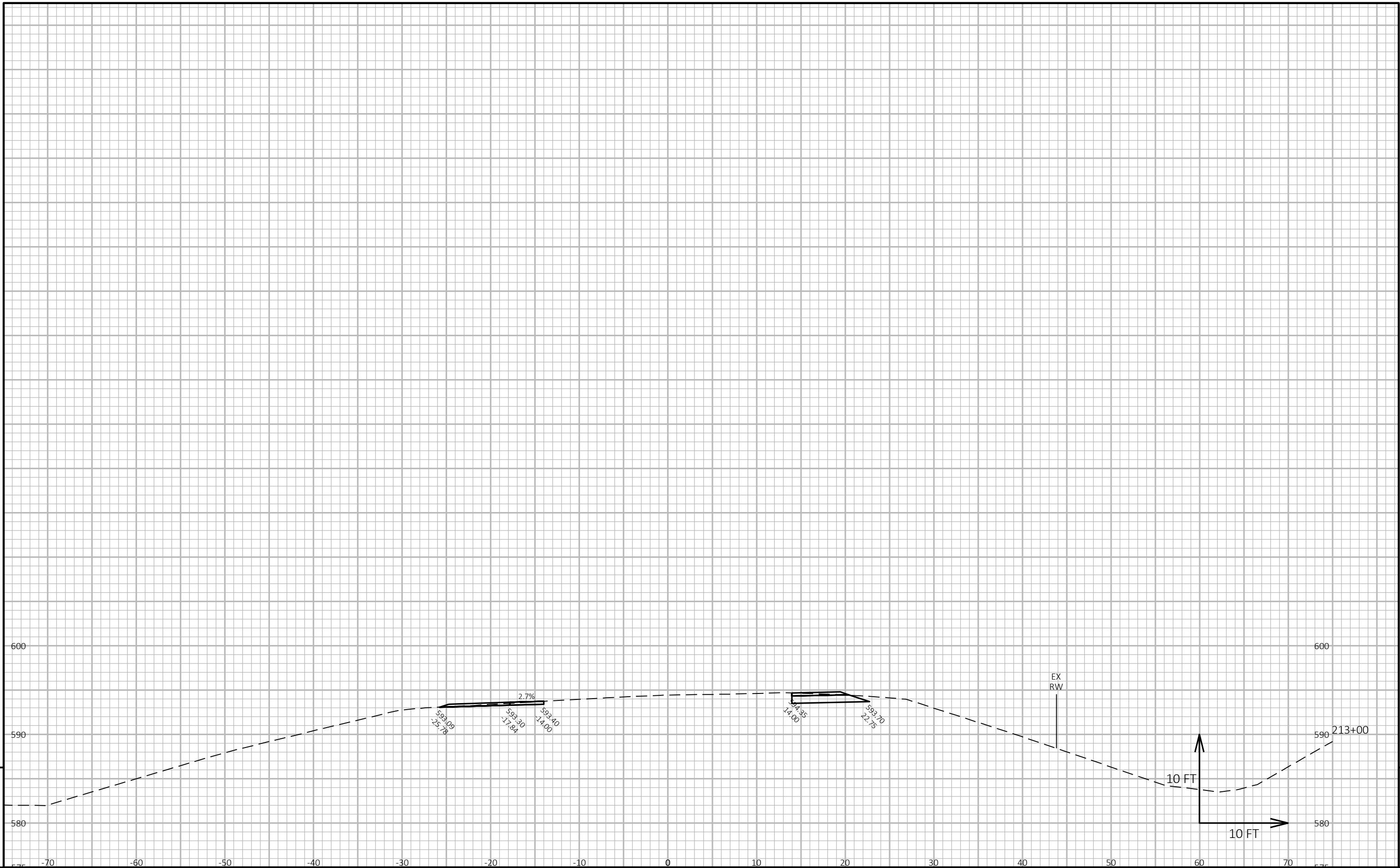

9

9

PROJECT NO: 4390-07-71	HWY: CTH C	COUNTY: KEWAUNEE	CROSS SECTIONS: MIDDLE GUARDRAIL	SHEET E
------------------------	------------	------------------	----------------------------------	---------

FILE NAME : I:\45\450511 KEWAUNEE CTH C ROADWAY\C3D\SHEETSPLAN\090201-XS.DWG  
 LAYOUT NAME - 090237-xs  
 PLOT DATE : 1/9/2024 12:20 PM  
 PLOT BY : GARNICA, BRANDON  
 PLOT NAME :  
 PLOT SCALE : 1 IN:10 FT HORZ. / 1 IN:10 FT VERT.  
 WISDOT/CADDs SHEET 49

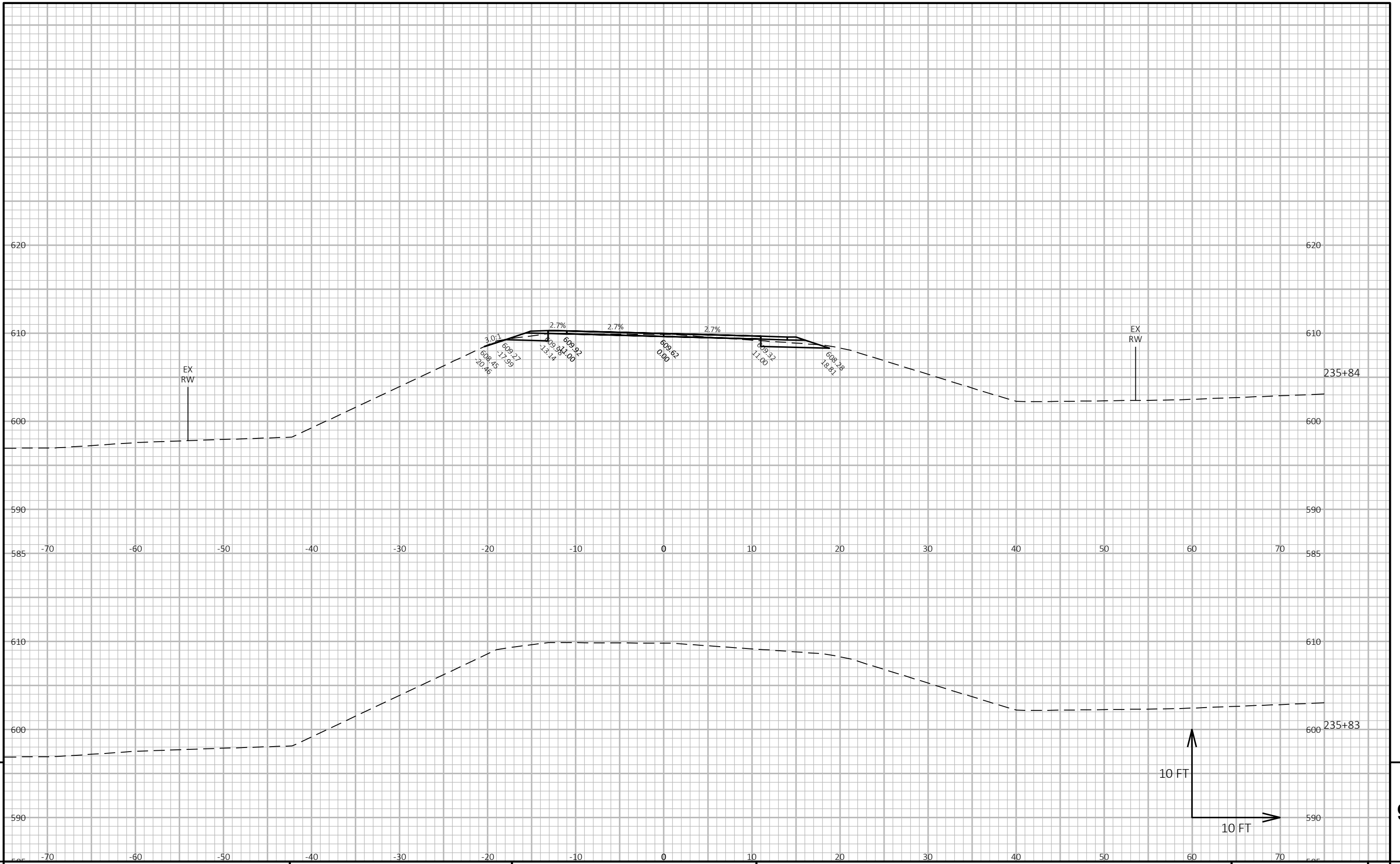

9

9

PROJECT NO: 4390-07-71      HWY: CTH C      COUNTY: KEWAUNEE      CROSS SECTIONS: EAST GUARDRAIL      SHEET      E

FILE NAME: I:\45\450511 KEWAUNEE CTH C ROADWAY\C3D\SHEETSPLAN\090201-XS.DWG      PLOT DATE: 1/9/2024 12:20 PM      PLOT BY: GARNICA, BRANDON      PLOT NAME:      PLOT SCALE: 1 IN:10 FT HORZ. / 1 IN:10 FT VERT.      WISDOT/CADD SHEET 49

LAYOUT NAME - 090238-xs

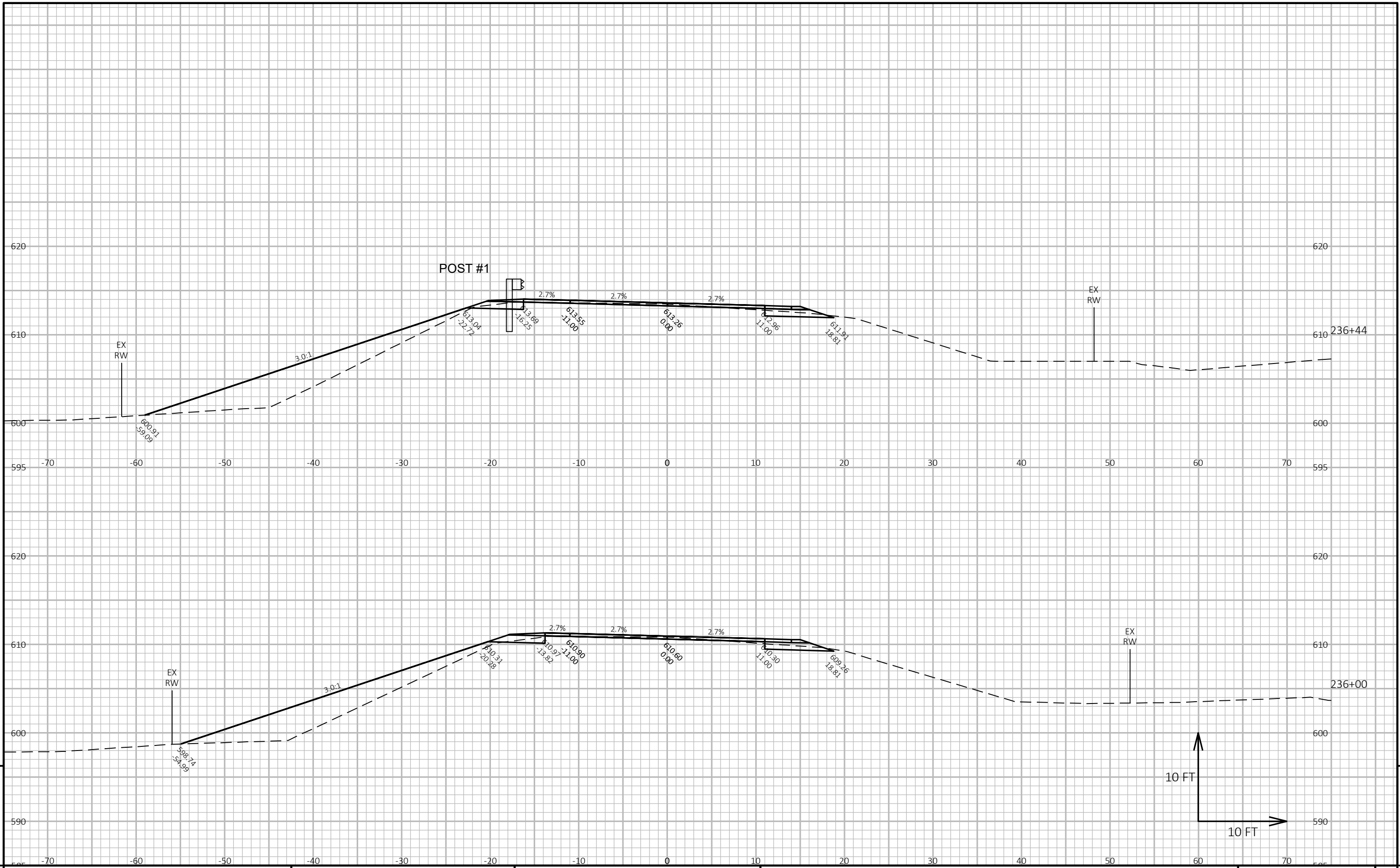

PROJECT NO: 4390-07-71      HWY: CTH C      COUNTY: KEWAUNEE      CROSS SECTIONS: EAST GUARDRAIL      SHEET      E

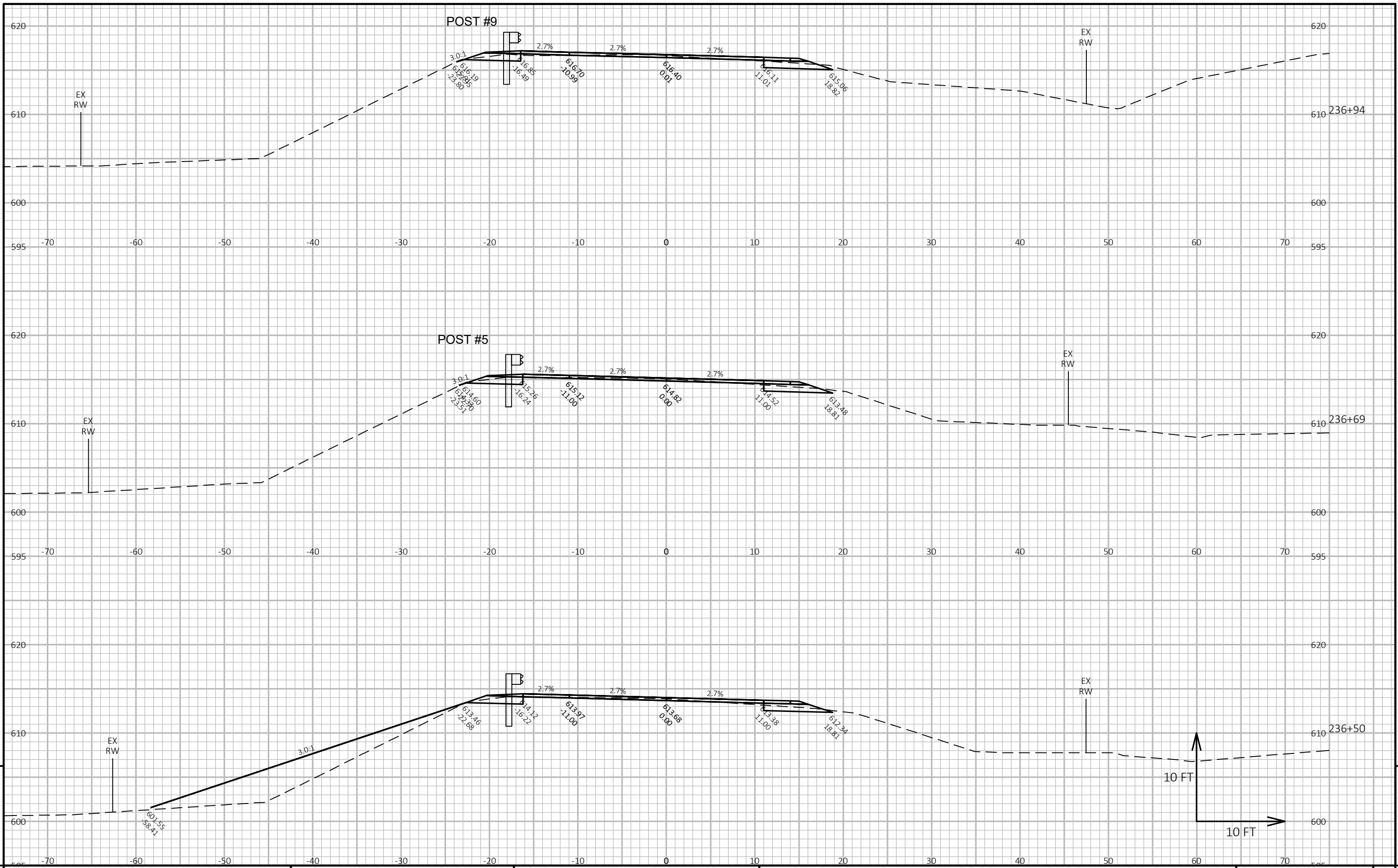

PROJECT NO: 4390-07-71	HWY: CTH C	COUNTY: KEWAUNEE	CROSS SECTIONS: EAST GUARDRAIL	SHEET	<b>9</b>
------------------------	------------	------------------	--------------------------------	-------	----------



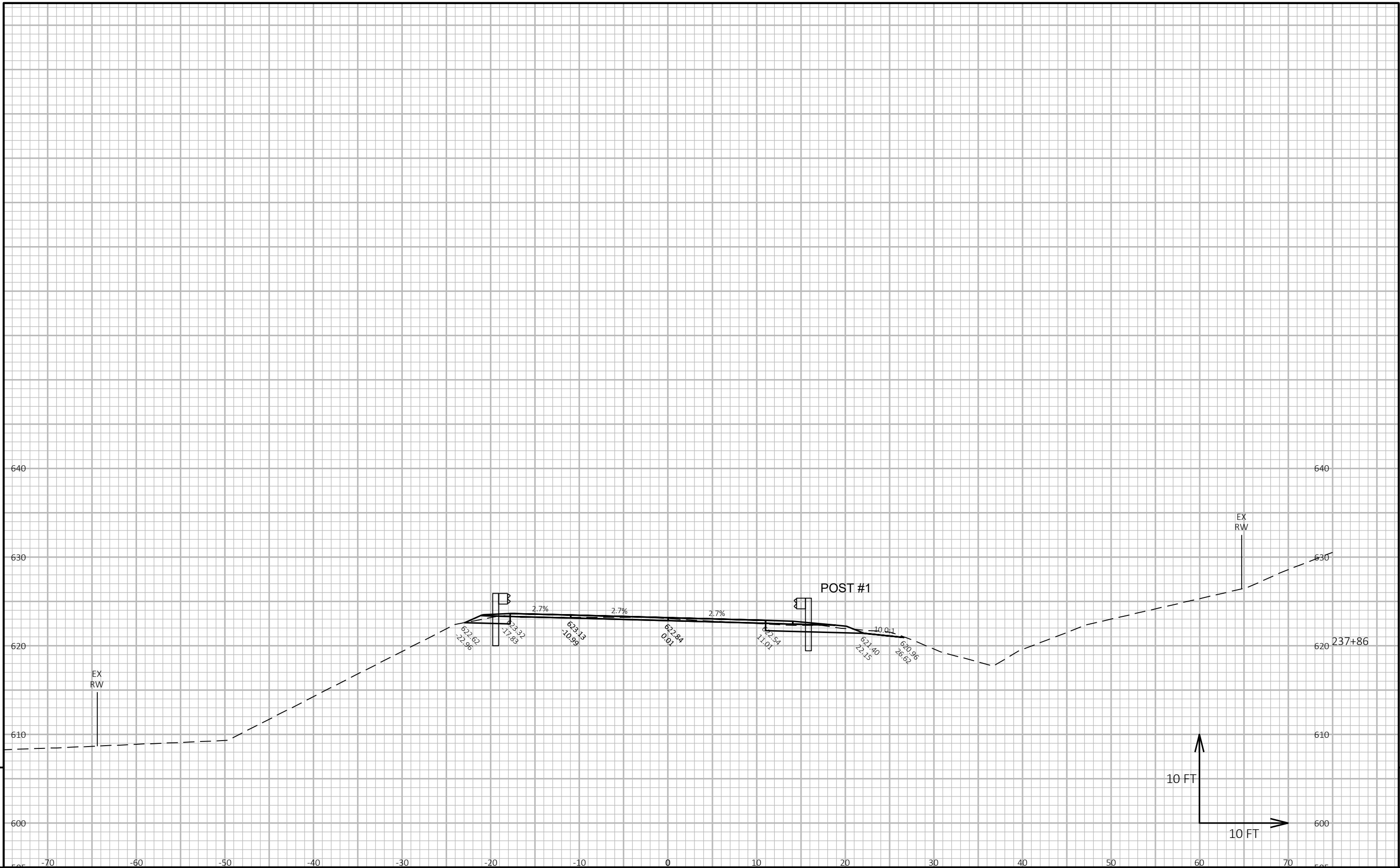

9

9

PROJECT NO: 4390-07-71      HWY: CTH C      COUNTY: KEWAUNEE      CROSS SECTIONS: EAST GUARDRAIL      SHEET E

FILE NAME: I:\45\450511 KEWAUNEE CTH C ROADWAY\C3D\SHEETSPLAN\090201-XS.DWG      PLOT DATE: 1/9/2024 12:20 PM      PLOT BY: GARNICA, BRANDON      PLOT NAME:      PLOT SCALE: 1 IN:10 FT HORZ. / 1 IN:10 FT VERT.      WISDOT/CADD SHEET 49

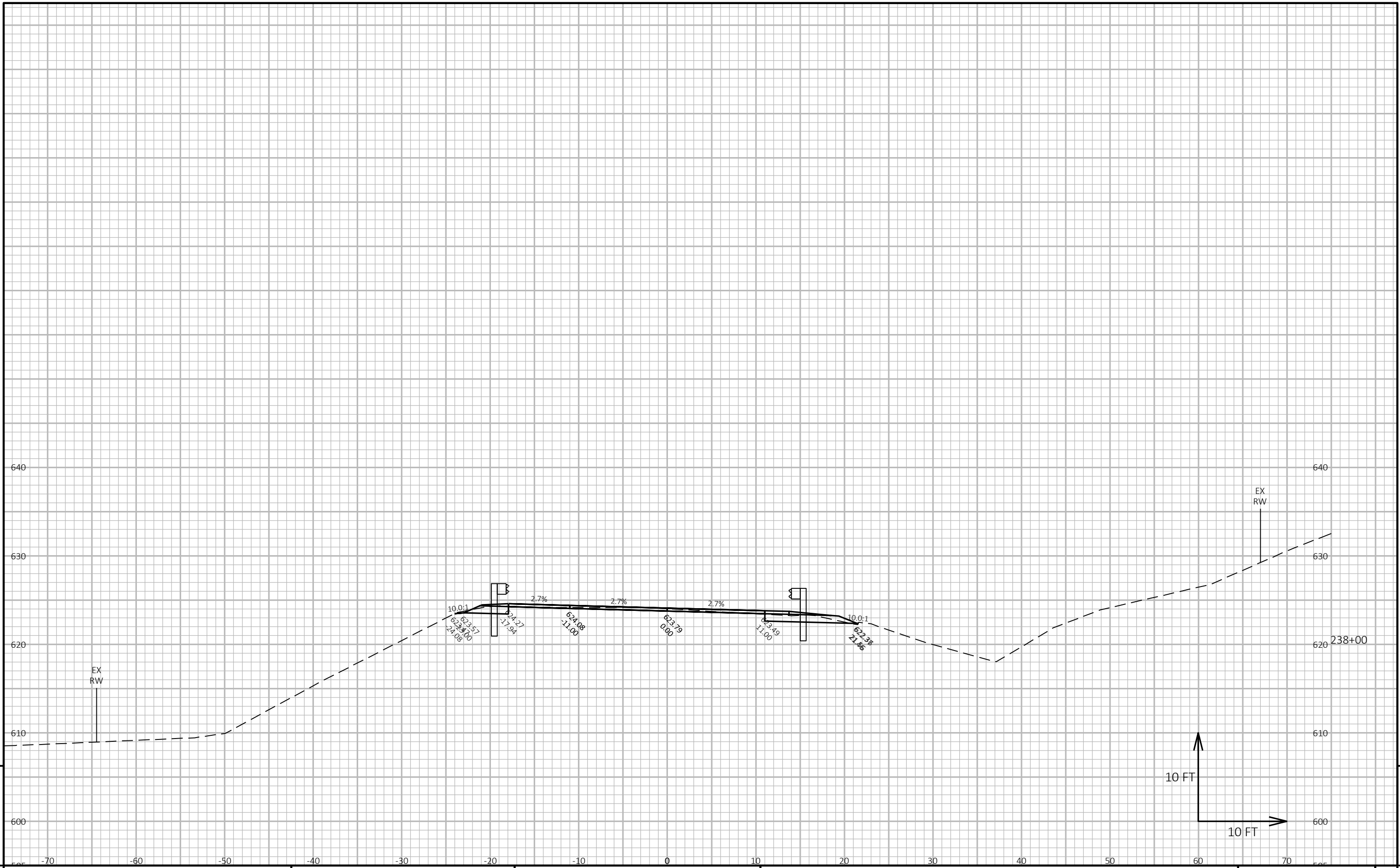

PROJECT NO: 4390-07-71      HWY: CTH C      COUNTY: KEWAUNEE      CROSS SECTIONS: EAST GUARDRAIL      SHEET 9





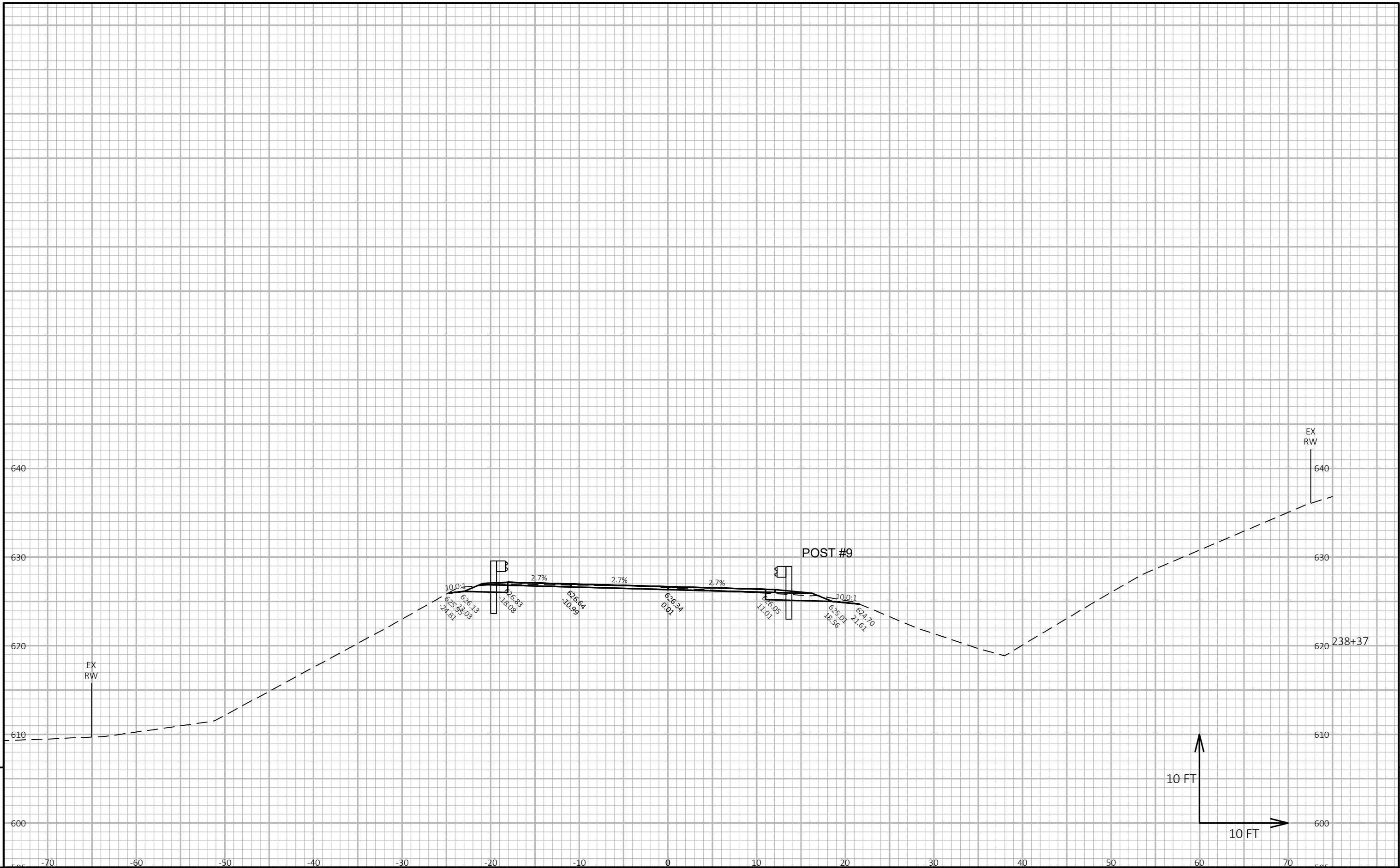

PROJECT NO: 4390-07-71

HWY: CTH C

COUNTY: KEWAUNEE

CROSS SECTIONS: EAST GUARDRAIL

SHEET

E

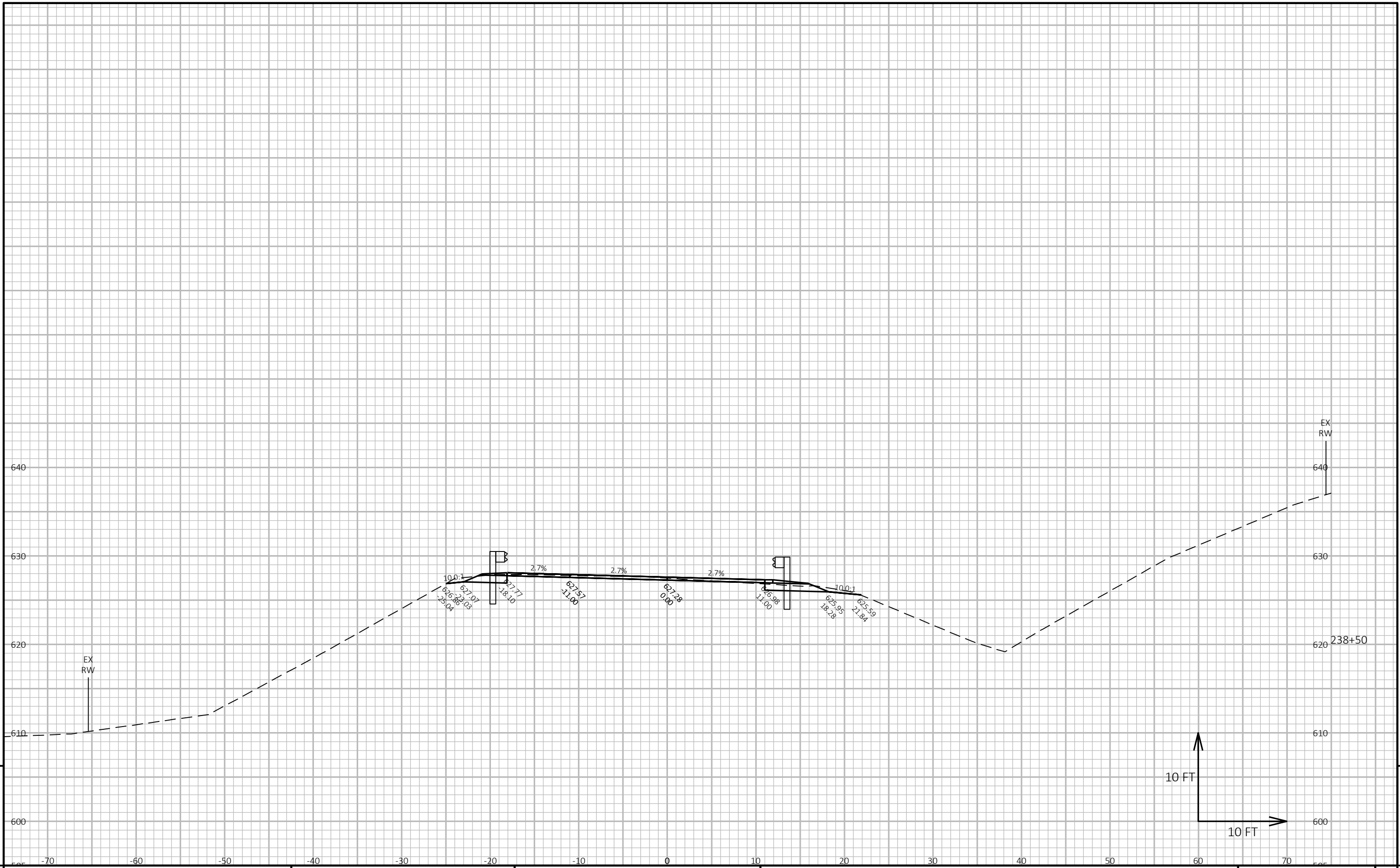

9

9

PROJECT NO: 4390-07-71      HWY: CTH C      COUNTY: KEWAUNEE      CROSS SECTIONS: EAST GUARDRAIL      SHEET      E

FILE NAME : I:\45\450511 KEWAUNEE CTH C ROADWAY\C3D\SHEETSPLAN\090201-XS.DWG      PLOT DATE : 1/9/2024 12:20 PM      PLOT BY : GARNICA, BRANDON      PLOT NAME :      PLOT SCALE : 1 IN:10 FT HORZ. / 1 IN:10 FT VERT.      WISDOT/CADD SHEET 49

LAYOUT NAME - 090246-xs



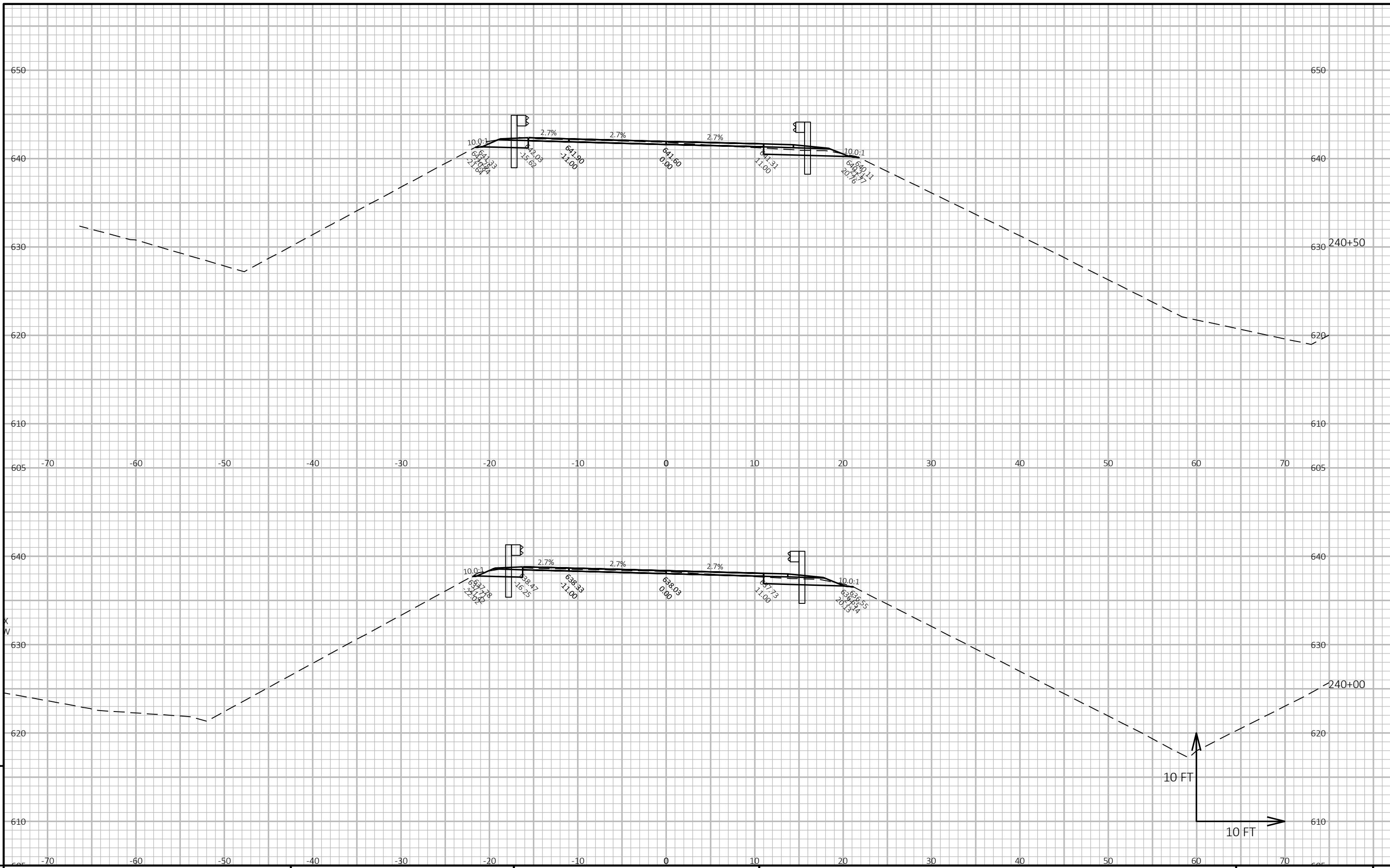

9

9

PROJECT NO: 4390-07-71	HWY: CTH C	COUNTY: KEWAUNEE	CROSS SECTIONS: EAST GUARDRAIL	SHEET E
------------------------	------------	------------------	--------------------------------	---------

FILE NAME : I:\45\450511 KEWAUNEE CTH C ROADWAY\C3D\SHEETSPLAN\090201-XS.DWG  
 PLOT DATE : 1/9/2024 12:20 PM  
 PLOT BY : GARNICA, BRANDON  
 PLOT NAME :  
 PLOT SCALE : 1 IN:10 FT HORZ. / 1 IN:10 FT VERT.  
 WISDOT/CADD SHEET 49

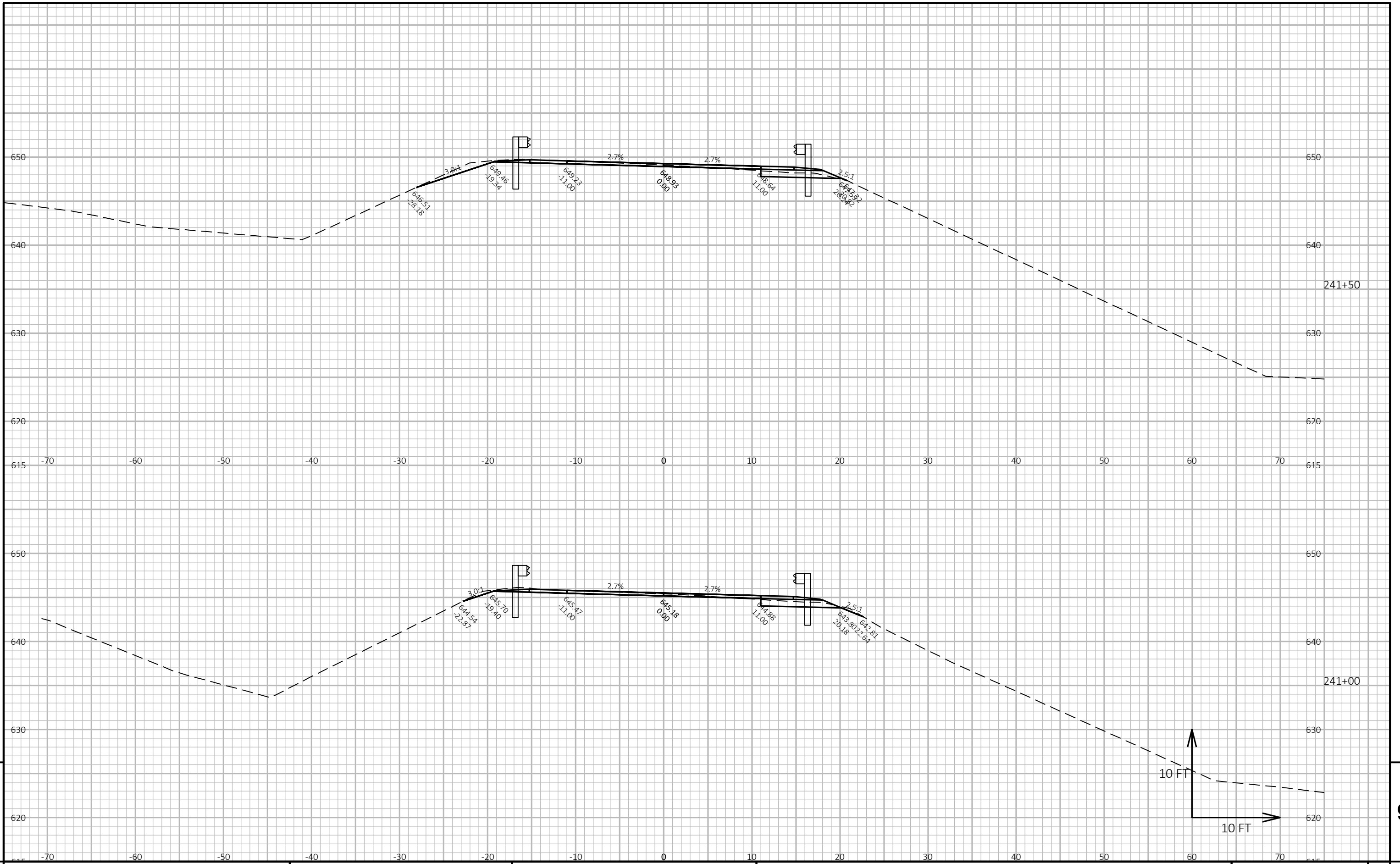

9

9

PROJECT NO: 4390-07-71      HWY: CTH C      COUNTY: KEWAUNEE      CROSS SECTIONS: EAST GUARDRAIL      SHEET      E

FILE NAME: I:\45\450511 KEWAUNEE CTH C ROADWAY\C3D\SHEETSPLAN\090201-XS.DWG      PLOT DATE: 1/9/2024 12:21 PM      PLOT BY: GARNICA, BRANDON      PLOT NAME:      PLOT SCALE: 1 IN:10 FT HORZ. / 1 IN:10 FT VERT.      WISDOT/CADD SHEET 49

LAYOUT NAME - 090249-xs

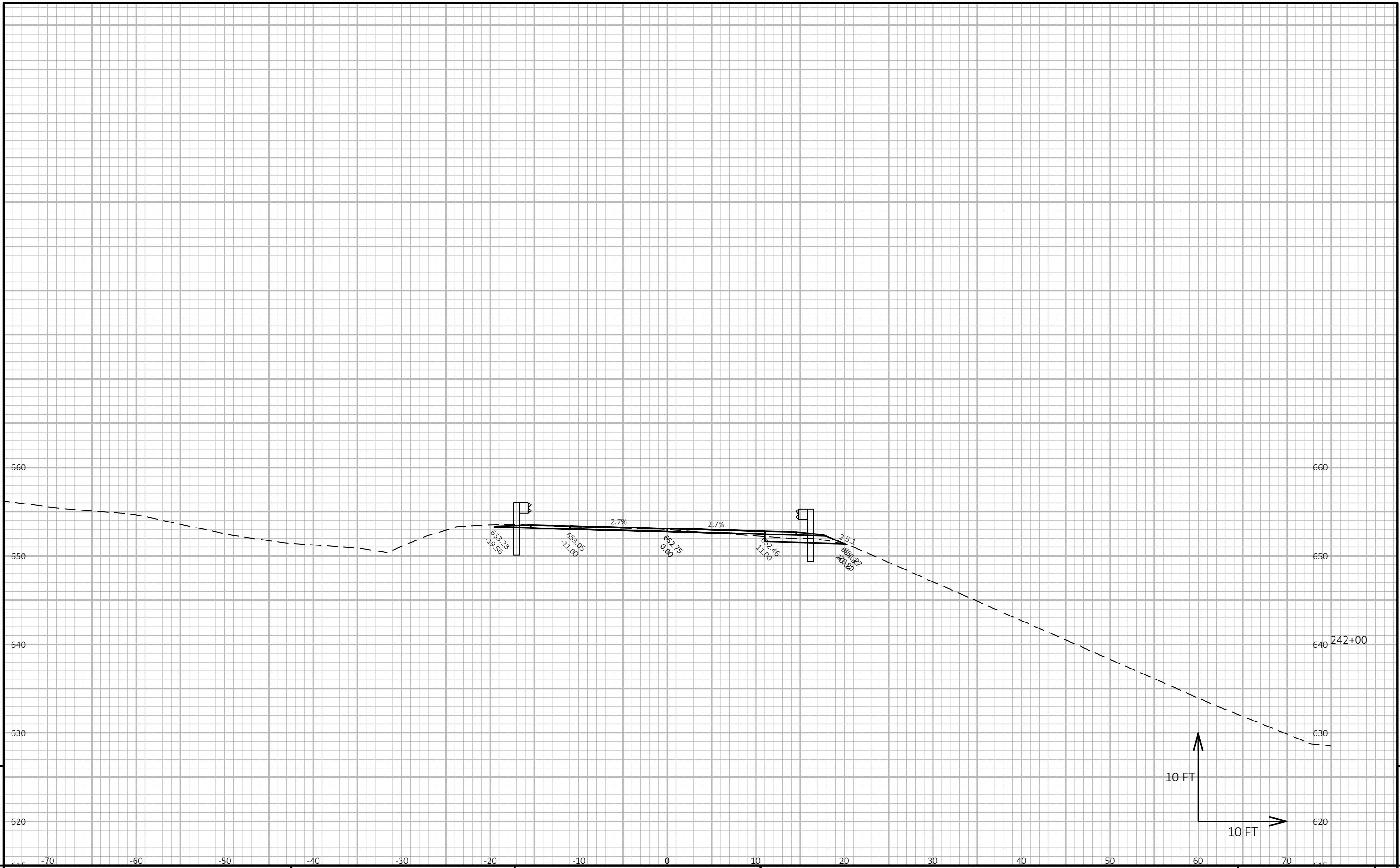

9

9

PROJECT NO: 4390-07-71      HWY: CTH C      COUNTY: KEWAUNEE      CROSS SECTIONS: EAST GUARDRAIL      SHEET E

FILE NAME: I:\45\450511 KEWAUNEE CTH C ROADWAY\C3D\SHEETSPLAN\090201-XS.DWG      PLOT DATE: 1/9/2024 12:21 PM      PLOT BY: GARNICA, BRANDON      PLOT NAME:      PLOT SCALE: 1 IN:10 FT HORZ. / 1 IN:10 FT VERT.      WISDOT/CADD SHEET 49

LAYOUT NAME - 090250-xs

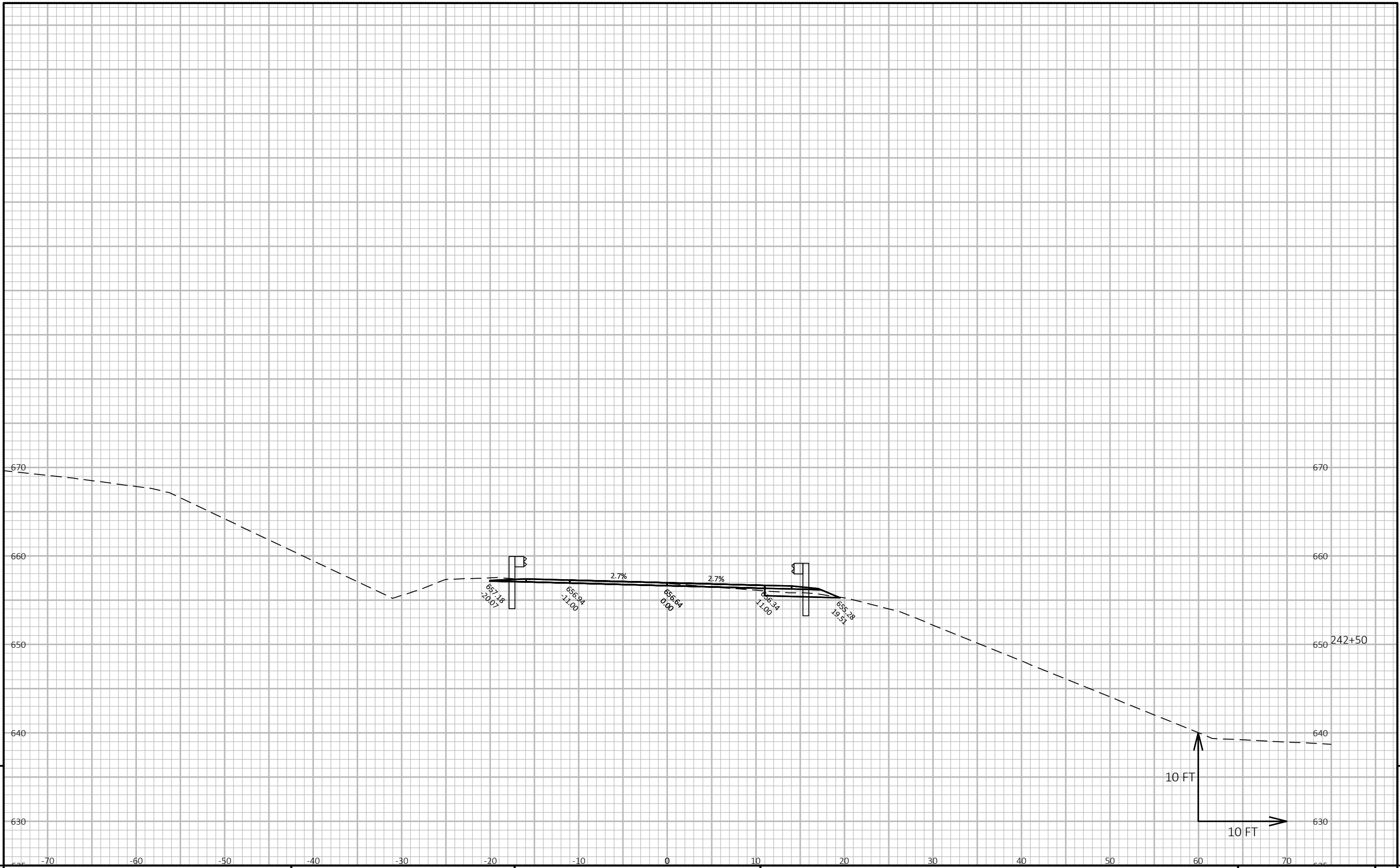

9

9

PROJECT NO: 4390-07-71	HWY: CTH C	COUNTY: KEWAUNEE	CROSS SECTIONS: EAST GUARDRAIL	SHEET	E
------------------------	------------	------------------	--------------------------------	-------	---

FILE NAME : I:\45\450511 KEWAUNEE CTH C ROADWAY\C3D\SHEETSPLAN\090201-XS.DWG  
 LAYOUT NAME - 090251-xs  
 PLOT DATE : 1/9/2024 12:21 PM  
 PLOT BY : GARNICA, BRANDON  
 PLOT NAME :  
 PLOT SCALE : 1 IN:10 FT HORZ. / 1 IN:10 FT VERT.  
 WISDOT/CADDs SHEET 49

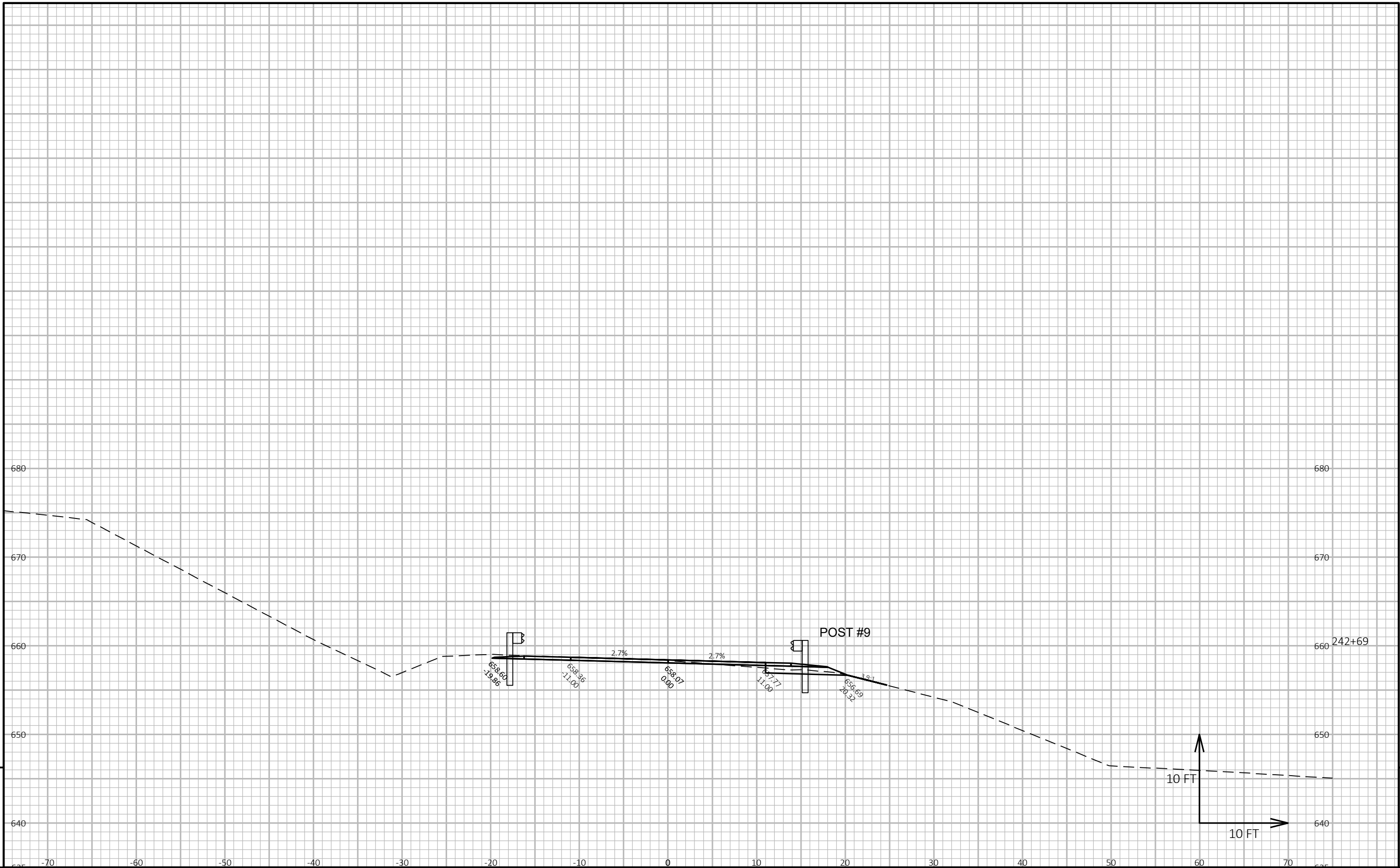

9

9

PROJECT NO: 4390-07-71      HWY: CTH C      COUNTY: KEWAUNEE      CROSS SECTIONS: EAST GUARDRAIL      SHEET E

FILE NAME: I:\45\450511 KEWAUNEE CTH C ROADWAY\C3D\SHEETSPLAN\090201-XS.DWG      PLOT DATE: 1/9/2024 12:21 PM      PLOT BY: GARNICA, BRANDON      PLOT NAME:      PLOT SCALE: 1 IN:10 FT HORZ. / 1 IN:10 FT VERT.      WISDOT/CADD SHEET 49

LAYOUT NAME - 090252-xs



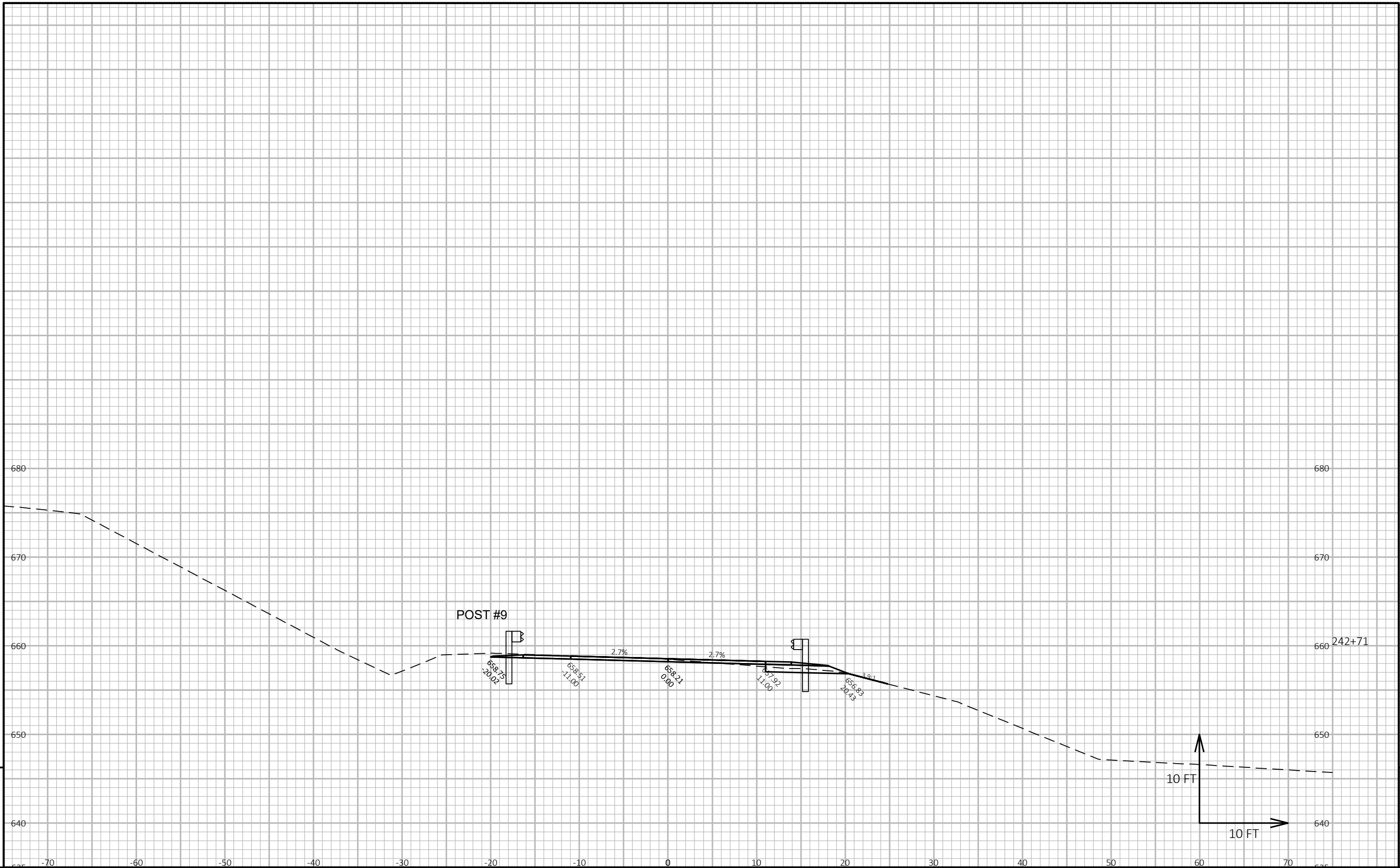

PROJECT NO: 4390-07-71	HWY: CTH C	COUNTY: KEWAUNEE	CROSS SECTIONS: EAST GUARDRAIL	SHEET	E
------------------------	------------	------------------	--------------------------------	-------	---

FILE NAME : I:\45\450511 KEWAUNEE CTH C ROADWAY\C3D\SHEETSPLAN\090201-XS.DWG  
 LAYOUT NAME - 090253-xs

PLOT DATE : 1/9/2024 12:21 PM

PLOT BY : GARNICA, BRANDON

PLOT NAME :

PLOT SCALE : 1 IN:10 FT HORZ. / 1 IN:10 FT VERT.

WISDOT/CADDs SHEET 49

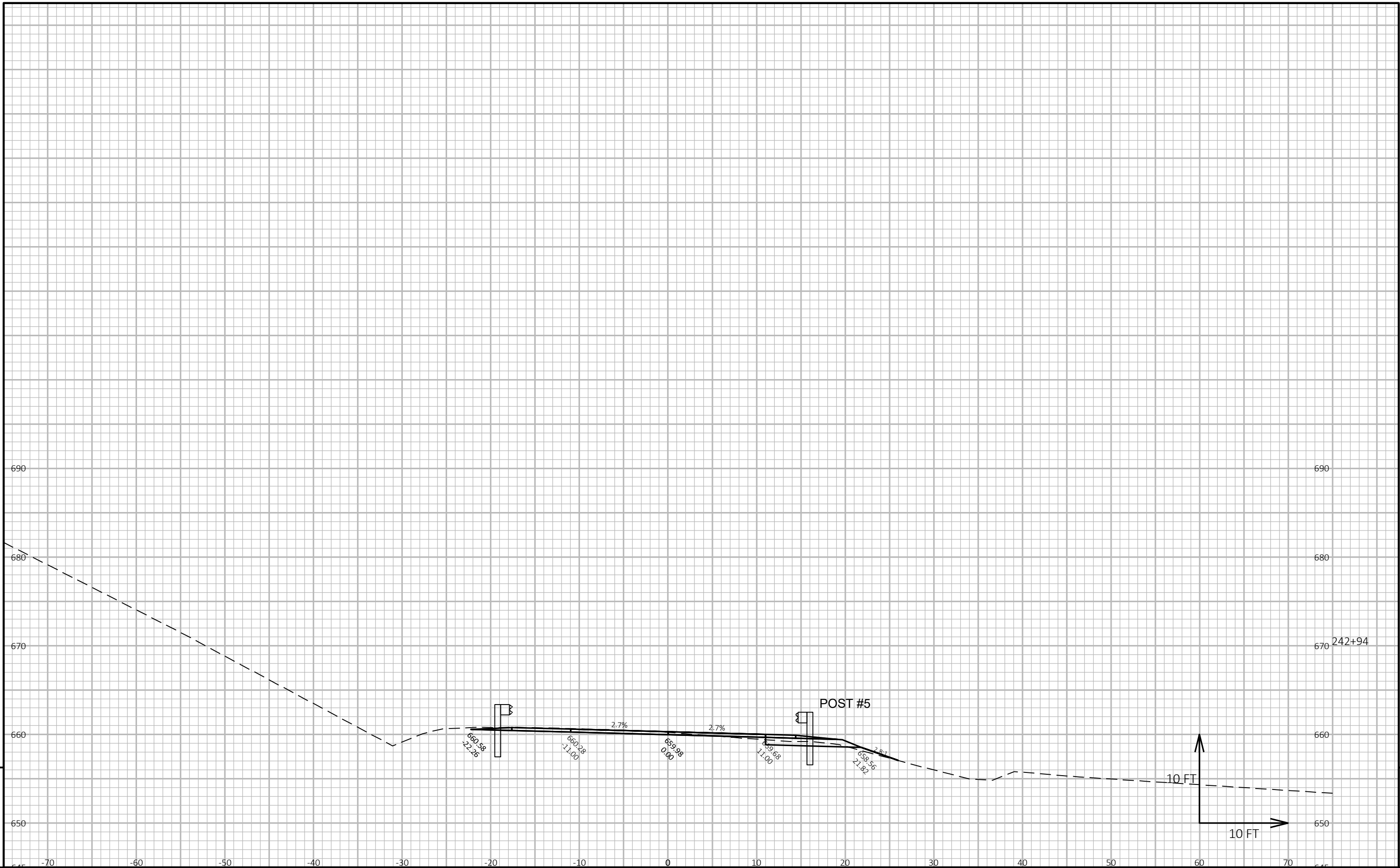

9

9

PROJECT NO: 4390-07-71	HWY: CTH C	COUNTY: KEWAUNEE	CROSS SECTIONS: EAST GUARDRAIL	SHEET	E
------------------------	------------	------------------	--------------------------------	-------	---

FILE NAME : I:\45\450511 KEWAUNEE CTH C ROADWAY\C3D\SHEETSPLAN\090201-XS.DWG  
 LAYOUT NAME - 090254-xs  
 PLOT DATE : 1/9/2024 12:21 PM  
 PLOT BY : GARNICA, BRANDON  
 PLOT NAME :  
 PLOT SCALE : 1 IN:10 FT HORZ. / 1 IN:10 FT VERT.  
 WISDOT/CADD SHEET 49

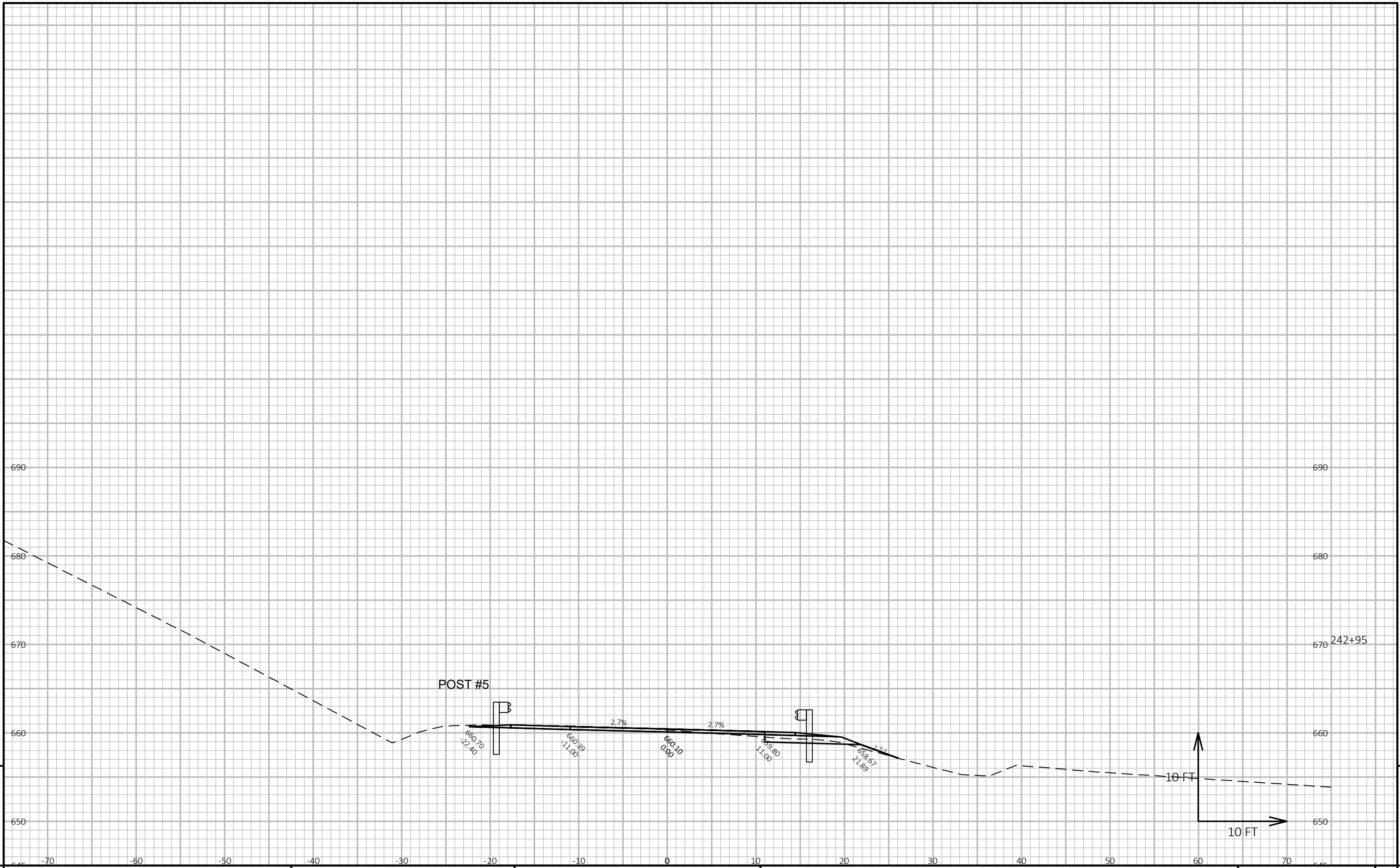

9

9

PROJECT NO: 4390-07-71	HWY: CTH C	COUNTY: KEWAUNEE	CROSS SECTIONS: EAST GUARDRAIL	SHEET	E
------------------------	------------	------------------	--------------------------------	-------	---

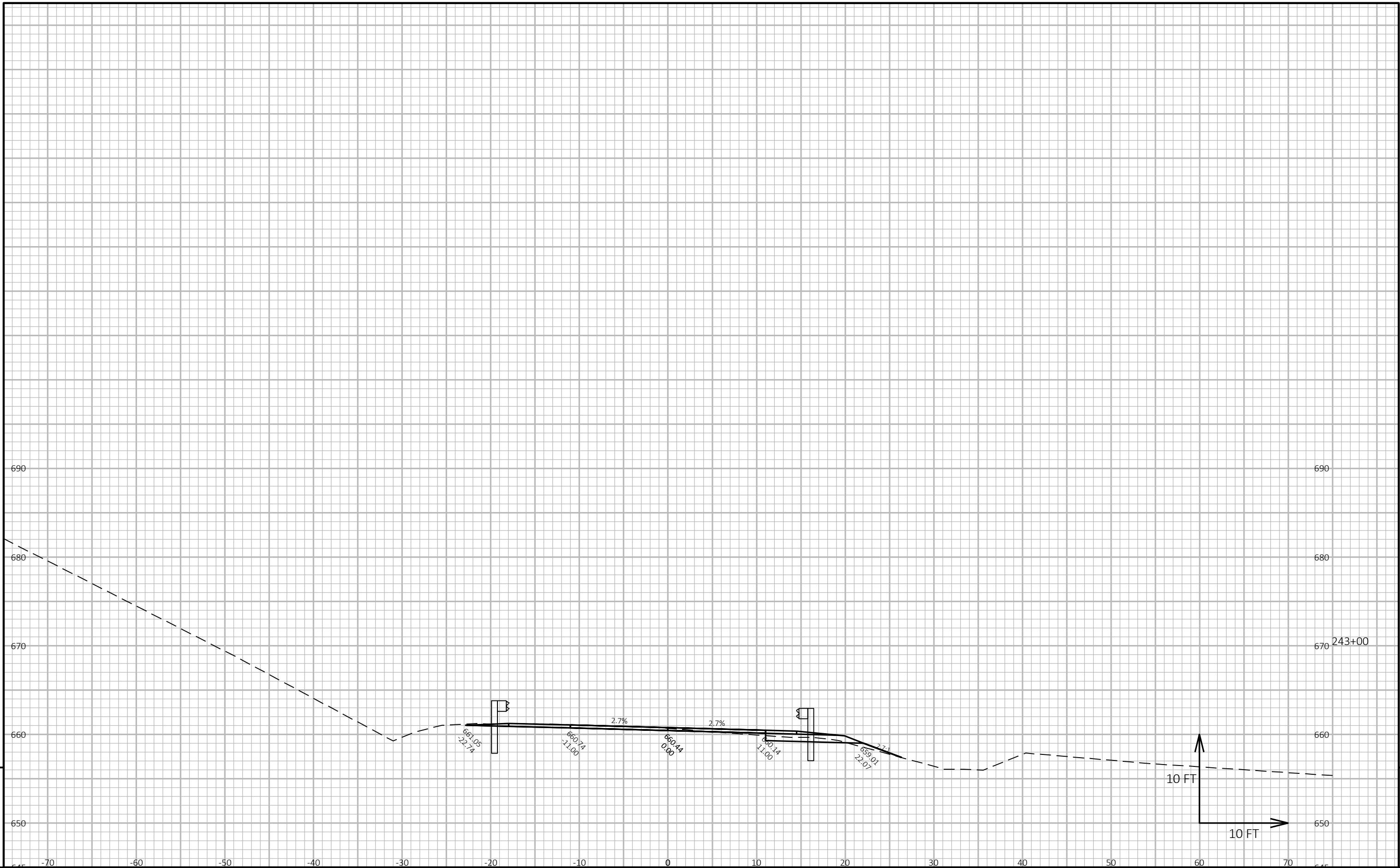

9

9

PROJECT NO: 4390-07-71	HWY: CTH C	COUNTY: KEWAUNEE	CROSS SECTIONS: EAST GUARDRAIL	SHEET	E
------------------------	------------	------------------	--------------------------------	-------	---

FILE NAME : I:\45\450511 KEWAUNEE CTH C ROADWAY\C3D\SHEETSPLAN\090201-XS.DWG  
 LAYOUT NAME - 090256-xs  
 PLOT DATE : 1/9/2024 12:21 PM  
 PLOT BY : GARNICA, BRANDON  
 PLOT NAME :  
 PLOT SCALE : 1 IN:10 FT HORZ. / 1 IN:10 FT VERT.  
 WISDOT/CADD SHEET 49

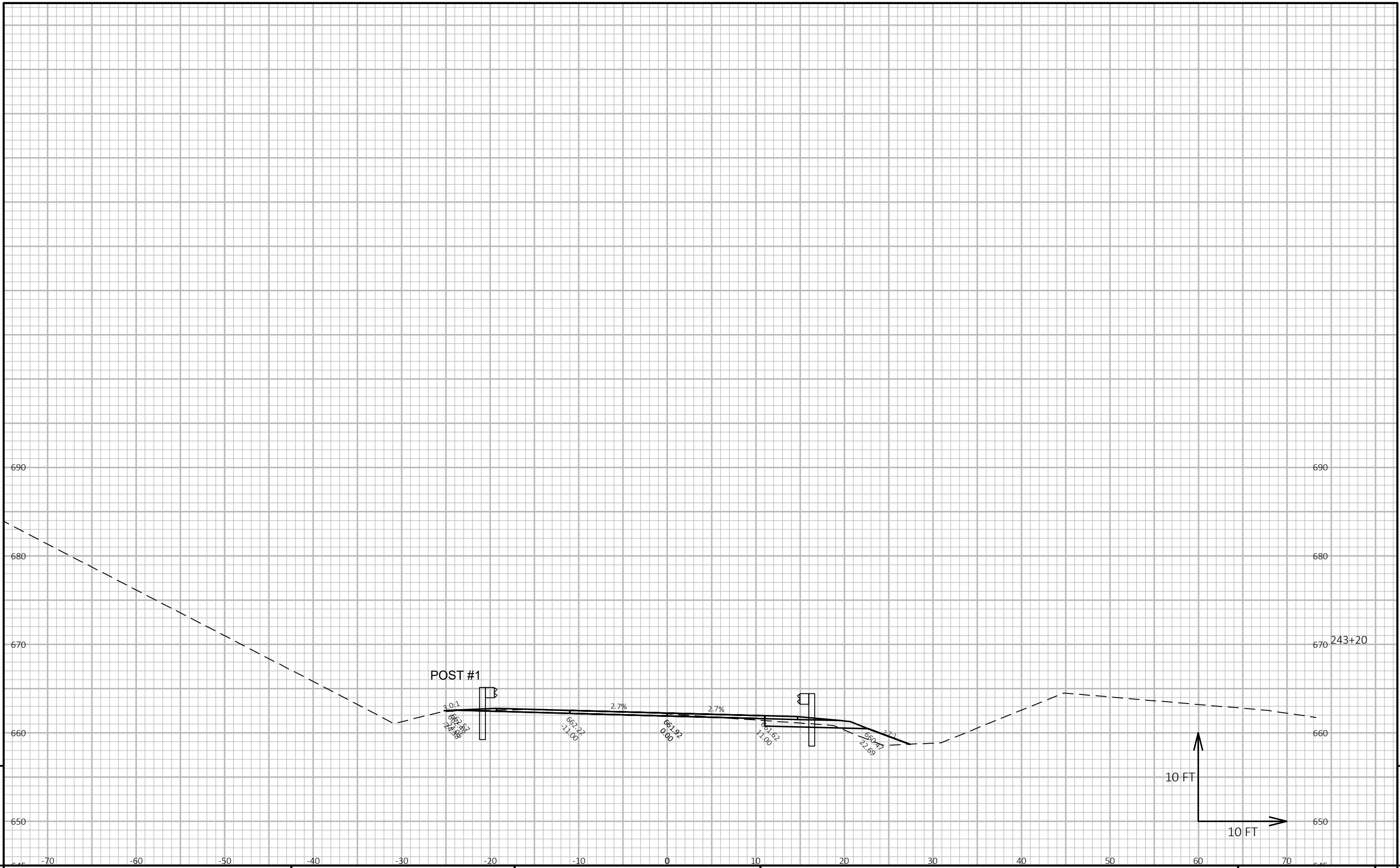

9

9

PROJECT NO: 4390-07-71	HWY: CTH C	COUNTY: KEWAUNEE	CROSS SECTIONS: EAST GUARDRAIL	SHEET	E
------------------------	------------	------------------	--------------------------------	-------	---

FILE NAME : I:\45\450511 KEWAUNEE CTH C ROADWAY\C3D\SHEETSPLAN\090201-XS.DWG PLOT DATE : 1/9/2024 12:21 PM PLOT BY : GARNICA, BRANDON PLOT NAME : PLOT SCALE : 1 IN:10 FT HORZ. / 1 IN:10 FT VERT. WISDOT/CADD SHEET 49

LAYOUT NAME - 090257-xs

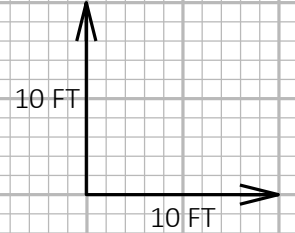
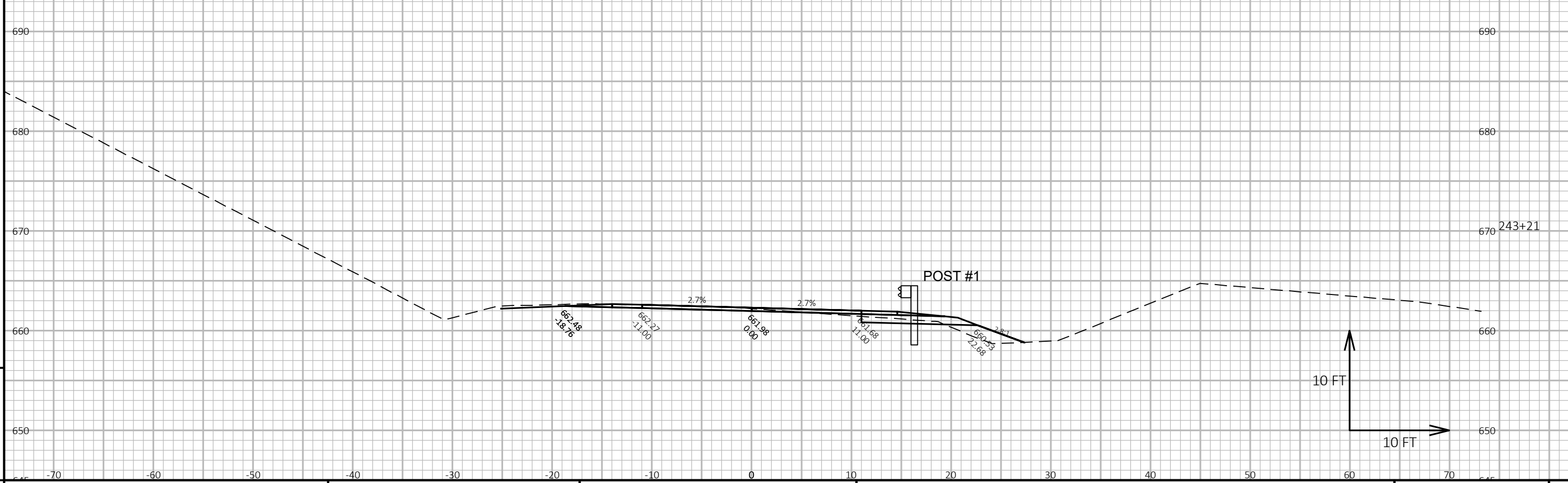
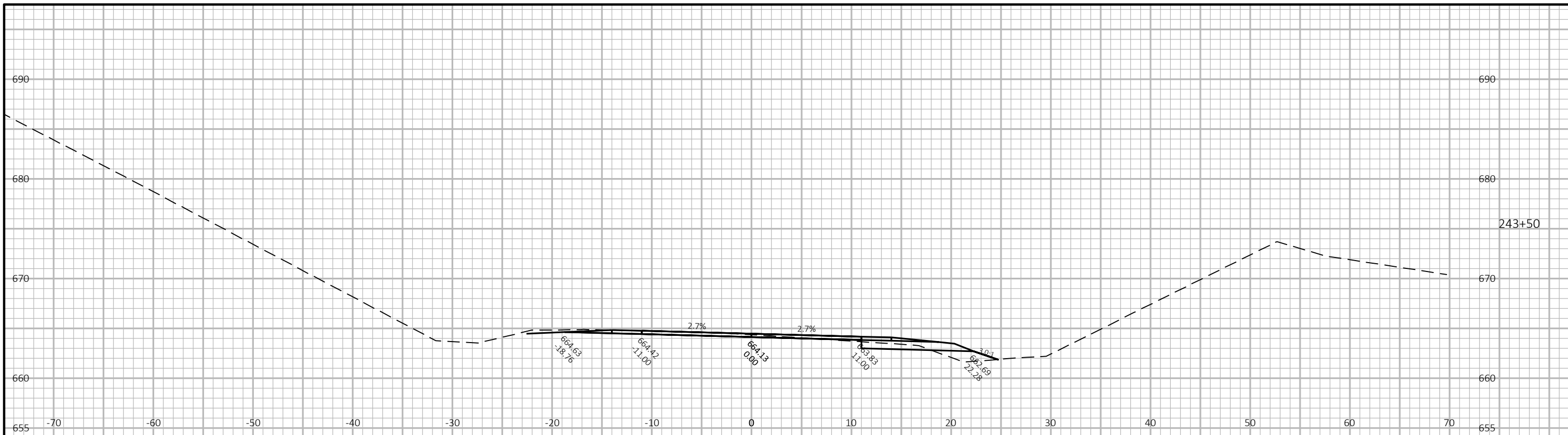

9

9

PROJECT NO: 4390-07-71	HWY: CTH C	COUNTY: KEWAUNEE	CROSS SECTIONS: EAST GUARDRAIL	SHEET	E
------------------------	------------	------------------	--------------------------------	-------	---

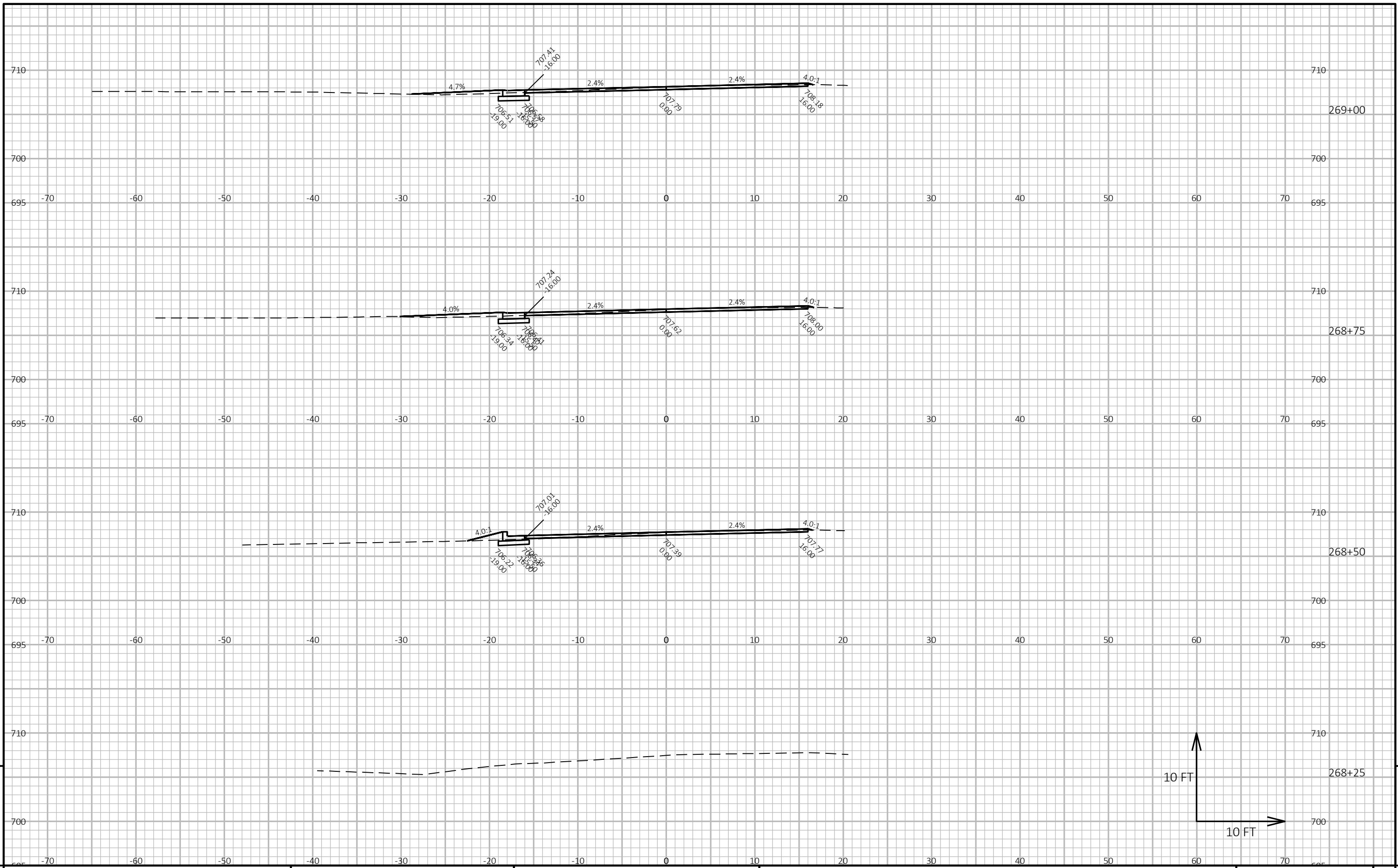

9

9

PROJECT NO: 4390-07-71      HWY: CTH C      COUNTY: KEWAUNEE      CROSS SECTIONS: ELLIS ST      SHEET      E

FILE NAME : I:\45\450511 KEWAUNEE CTH C ROADWAY\C3D\SHEETSPLAN\090201-XS.DWG      PLOT DATE : 1/9/2024 12:21 PM      PLOT BY : GARNICA, BRANDON      PLOT NAME :      PLOT SCALE : 1 IN:10 FT HORZ. / 1 IN:10 FT VERT.      WISDOT/CADD SHEET 49

LAYOUT NAME - 090261-xs

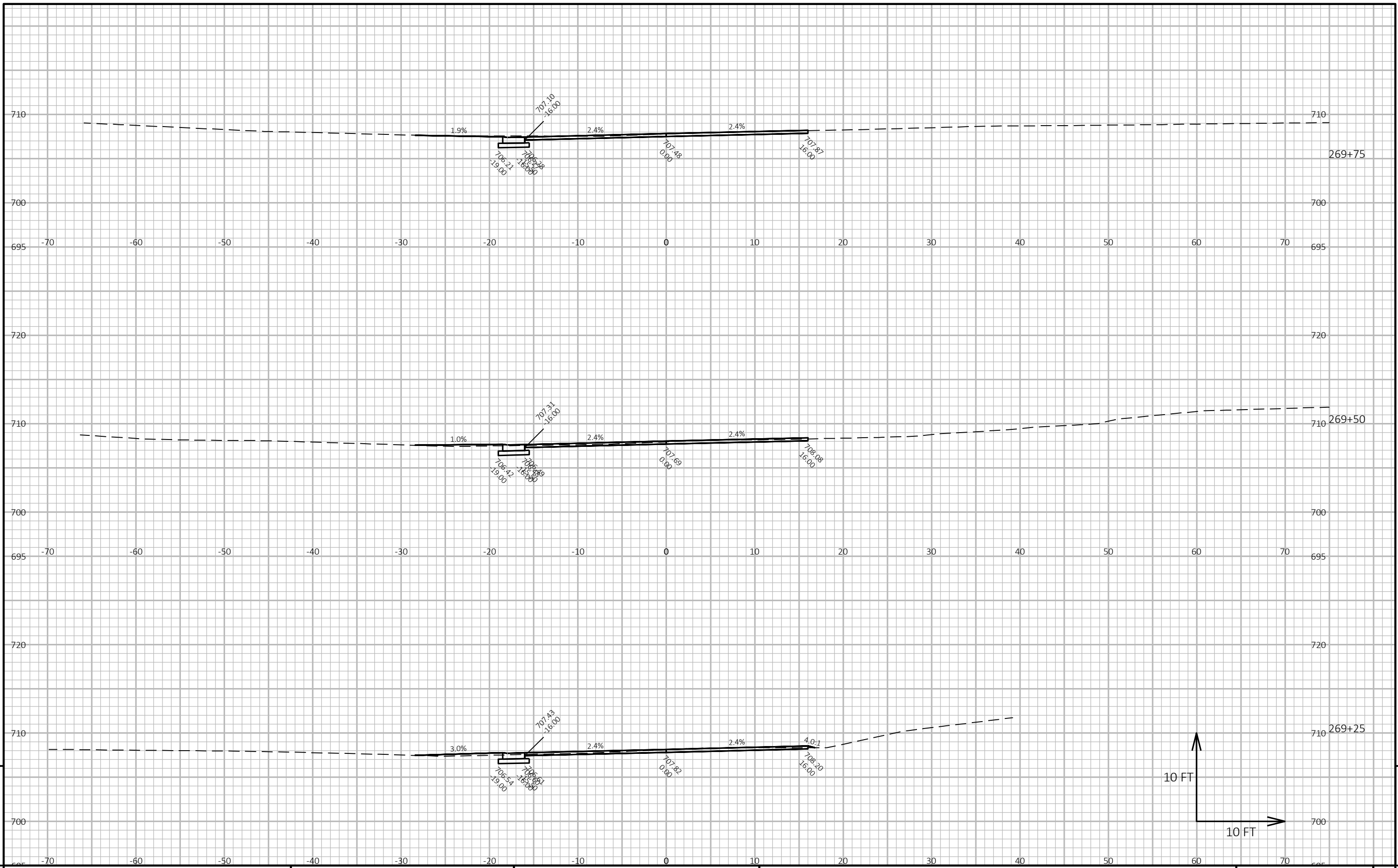

9

9

PROJECT NO: 4390-07-71      HWY: CTH C      COUNTY: KEWAUNEE      CROSS SECTIONS: ELLIS ST      SHEET      E

FILE NAME : I:\45\450511 KEWAUNEE CTH C ROADWAY\C3D\SHEETSPLAN\090201-XS.DWG      PLOT DATE : 1/9/2024 12:21 PM      PLOT BY : GARNICA, BRANDON      PLOT NAME :      PLOT SCALE : 1 IN:10 FT HORZ. / 1 IN:10 FT VERT.      WISDOT/CADD SHEET 49

LAYOUT NAME - 090262-xs



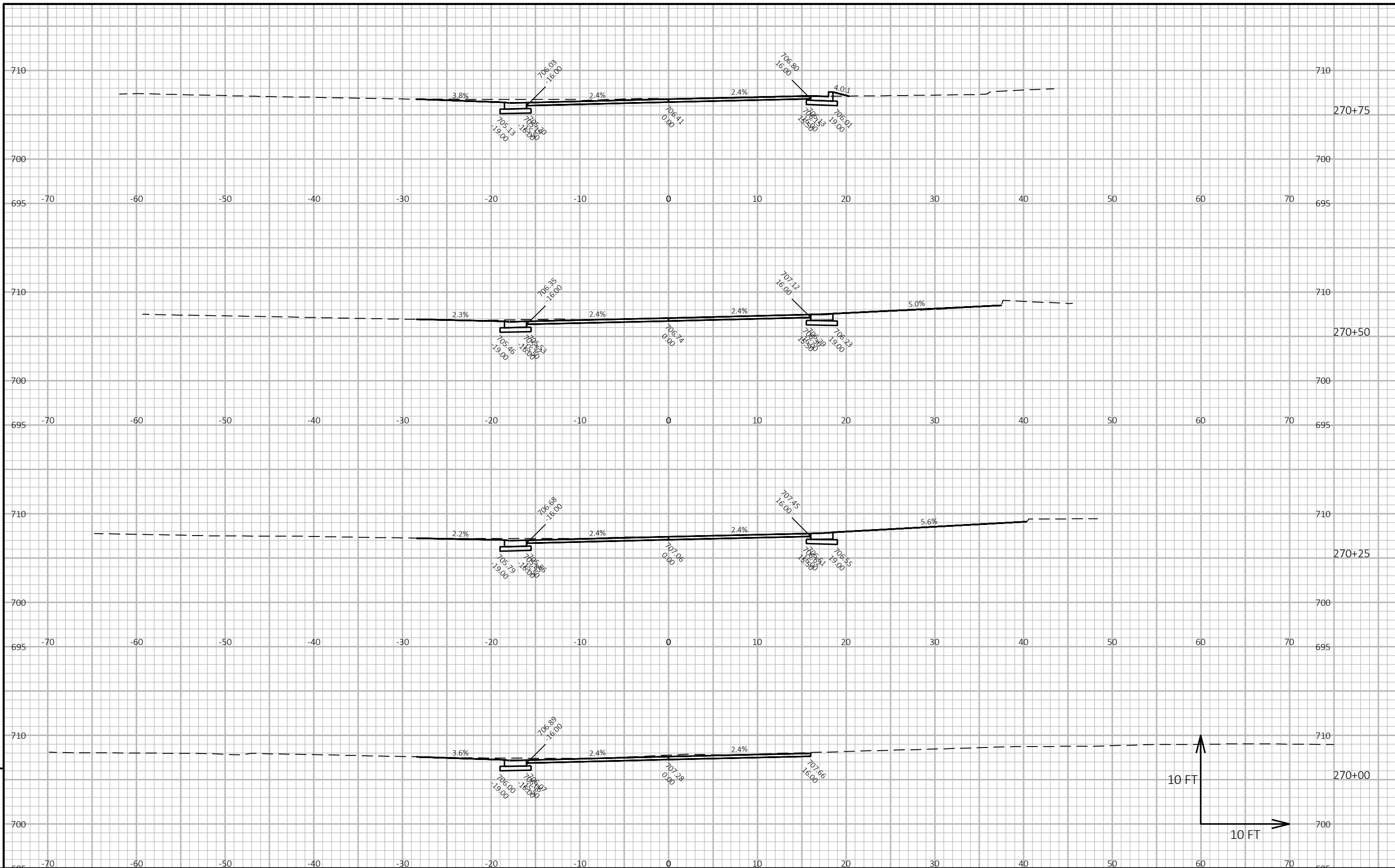

9

9

PROJECT NO: 4390-07-71      HWY: CTH C      COUNTY: KEWAUNEE      CROSS SECTIONS: ELLIS ST      SHEET      E

FILE NAME : I:\451450511 KEWAUNEE CTH C ROADWAY\C3D\SHEETSPLAN\090201-XS.DWG      PLOT DATE : 1/9/2024 12:22 PM      PLOT BY : GARNICA, BRANDON      PLOT NAME :      PLOT SCALE : 1 IN:10 FT HORZ. / 1 IN:10 FT VERT.      WISDOT/CADD SHEET 49

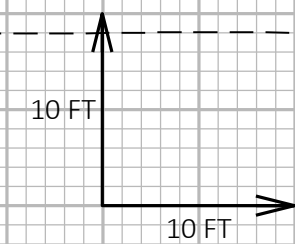

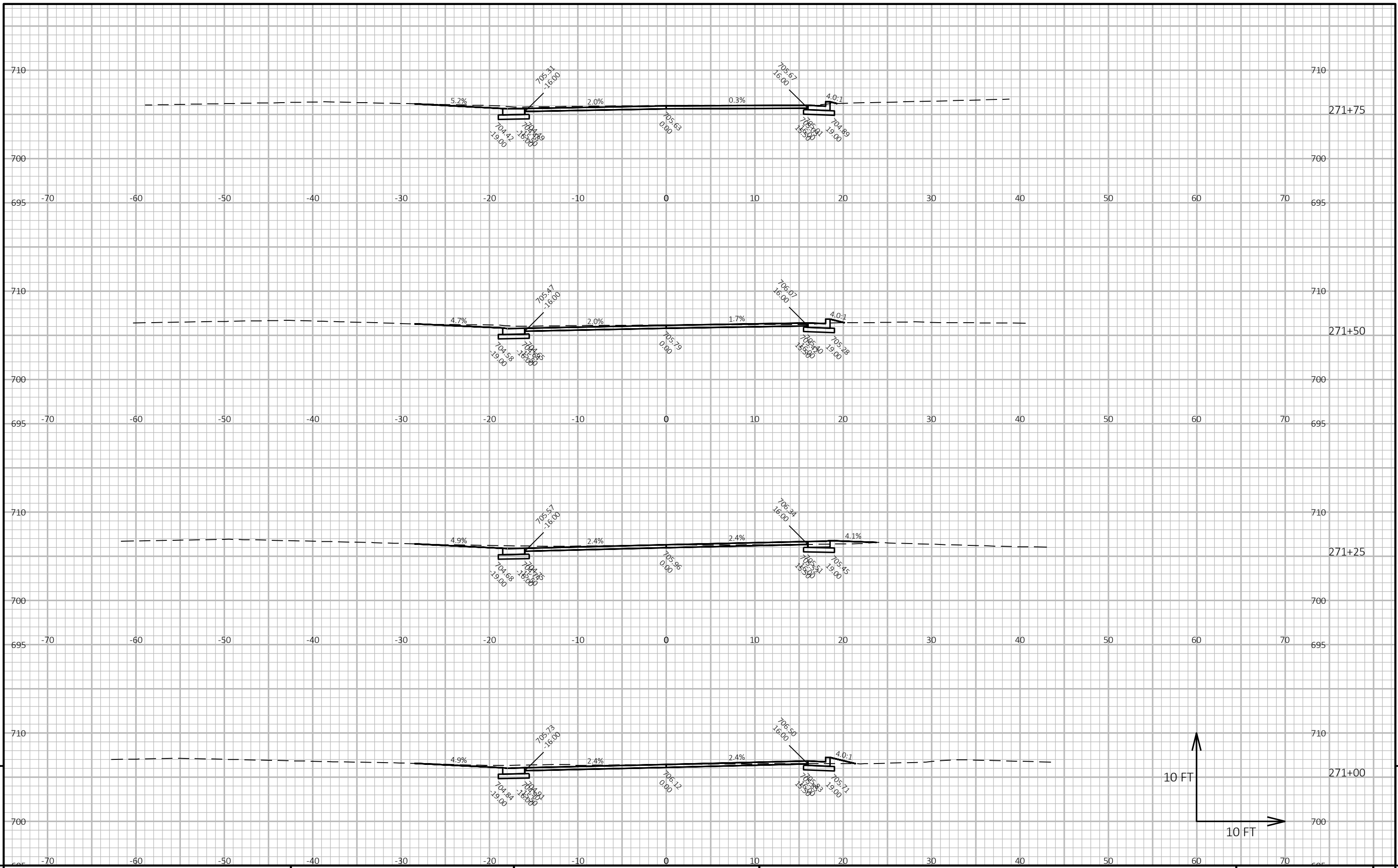

9

9

PROJECT NO: 4390-07-71      HWY: CTH C      COUNTY: KEWAUNEE      CROSS SECTIONS: ELLIS ST      SHEET      E

FILE NAME : I:\45\450511 KEWAUNEE CTH C ROADWAY\C3D\SHEETSPLAN\090201-XS.DWG      PLOT DATE : 1/9/2024 12:22 PM      PLOT BY : GARNICA, BRANDON      PLOT NAME :      PLOT SCALE : 1 IN:10 FT HORZ. / 1 IN:10 FT VERT.      WISDOT/CADDs SHEET 49

LAYOUT NAME - 090264-xs

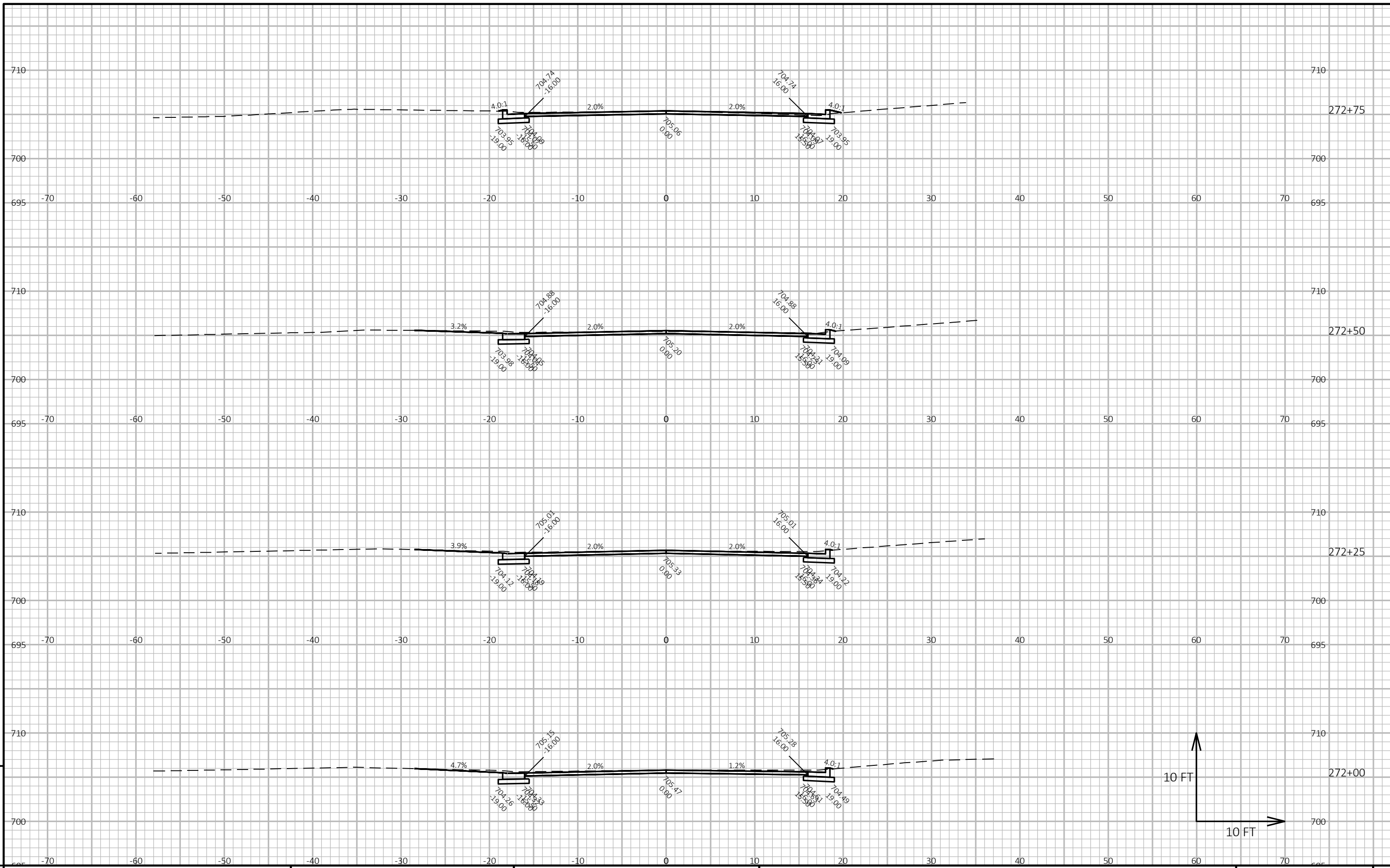

9

9

PROJECT NO: 4390-07-71      HWY: CTH C      COUNTY: KEWAUNEE      CROSS SECTIONS: ELLIS ST      SHEET      E

FILE NAME : I:\45\450511 KEWAUNEE CTH C ROADWAY\C3D\SHEETSPLAN\090201-XS.DWG      PLOT DATE : 1/9/2024 12:22 PM      PLOT BY : GARNICA, BRANDON      PLOT NAME :      PLOT SCALE : 1 IN:10 FT HORZ. / 1 IN:10 FT VERT.      WISDOT/CADD SHEET 49

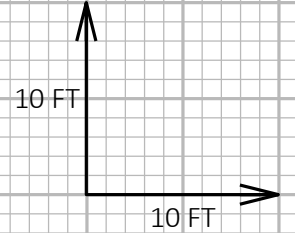

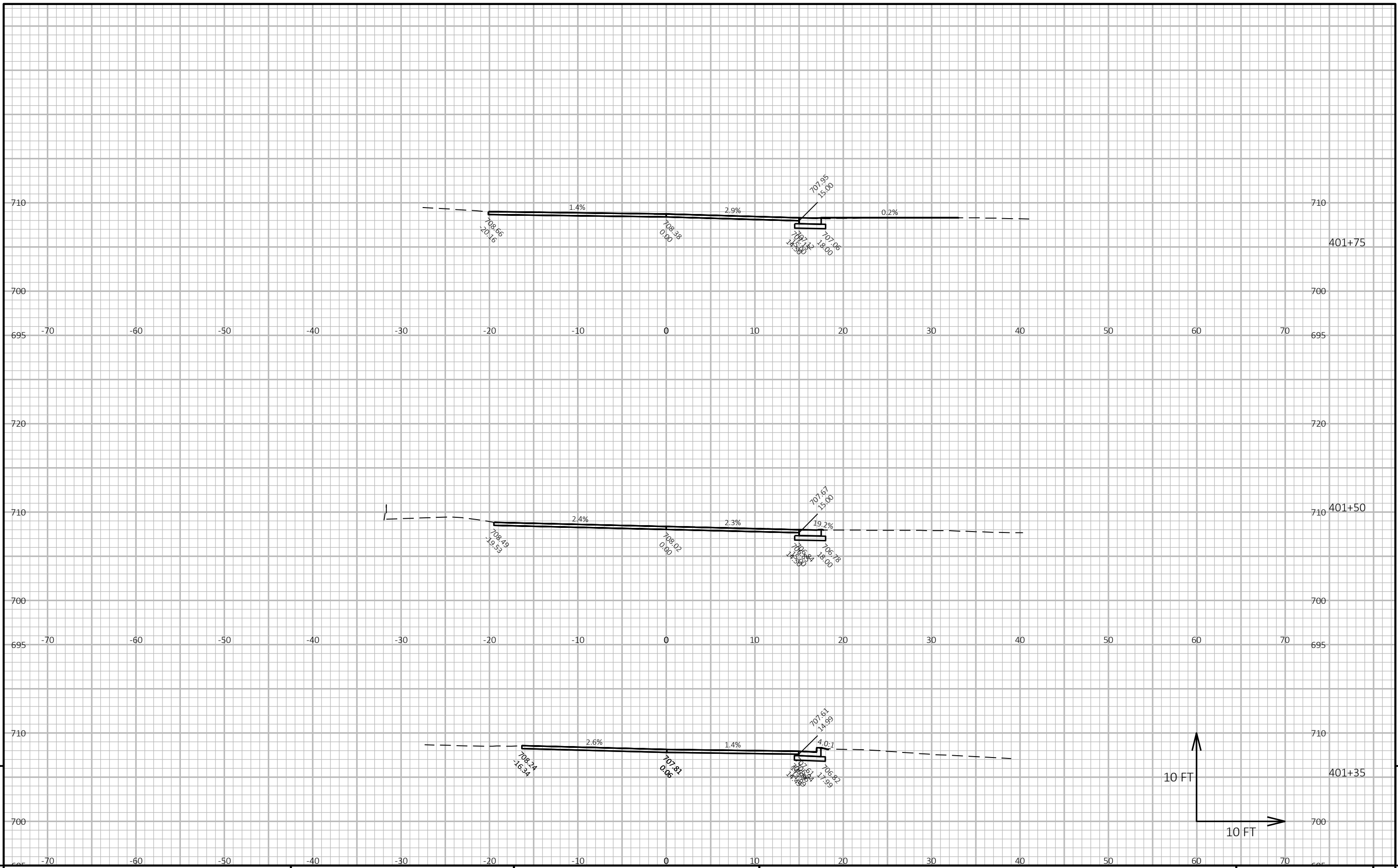

9

9

PROJECT NO: 4390-07-71      HWY: CTH C      COUNTY: KEWAUNEE      CROSS SECTIONS: FRANKLIN ST      SHEET E

FILE NAME : I:\451450511 KEWAUNEE CTH C ROADWAY\C3D\SHEETSPLAN\090201-XS.DWG      PLOT DATE : 1/9/2024 12:22 PM      PLOT BY : GARNICA, BRANDON      PLOT NAME :      PLOT SCALE : 1 IN:10 FT HORZ. / 1 IN:10 FT VERT.      WISDOT/CADD SHEET 49

LAYOUT NAME - 090267-xs

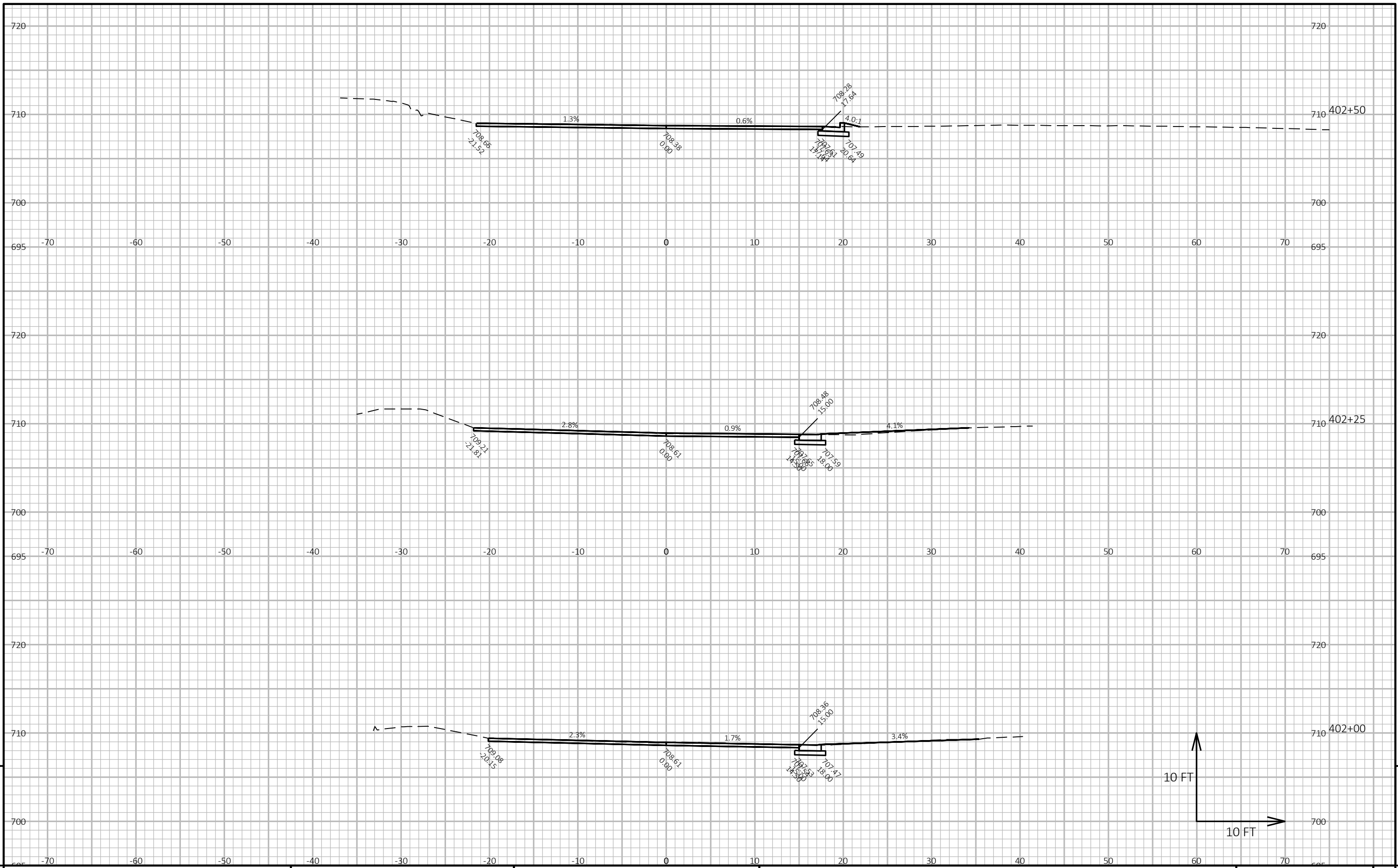

9

9

PROJECT NO: 4390-07-71      HWY: CTH C      COUNTY: KEWAUNEE      CROSS SECTIONS: FRANKLIN ST      SHEET      E

FILE NAME : I:\45\450511 KEWAUNEE CTH C ROADWAY\C3D\SHEETSPLAN\090201-XS.DWG      PLOT DATE : 1/9/2024 12:22 PM      PLOT BY : GARNICA, BRANDON      PLOT NAME :      PLOT SCALE : 1 IN:10 FT HORZ. / 1 IN:10 FT VERT.      WISDOT/CADD SHEET 49

# Notes

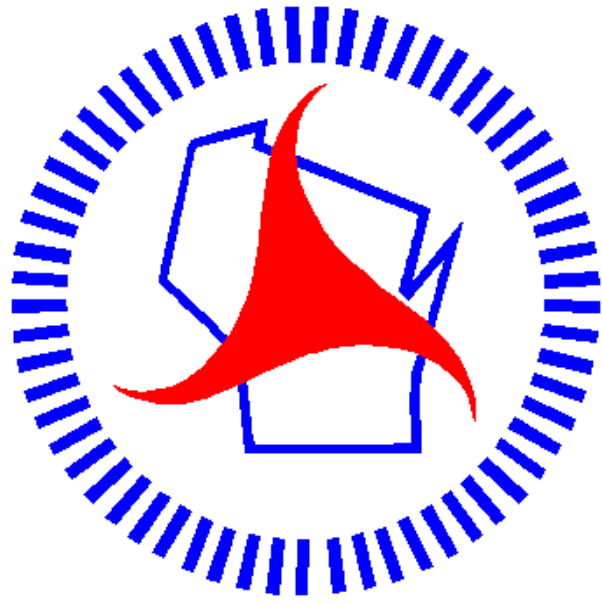

## ***Wisconsin Department of Transportation***

Dedicated people creating transportation solutions through innovation and exceptional service.

<http://www.dot.wisconsin.gov>