

PROJECT ID 1440-13/15-00 FHWA-WI-EIS-04-03-LS SSF
WISCONSIN STATE HIGHWAY 23
FOND DU LAC to PLYMOUTH
FOND DU LAC AND SHEBOYGAN COUNTIES, WISCONSIN

2018 LIMITED SCOPE SUPPLEMENTAL FINAL ENVIRONMENTAL IMPACT STATEMENT,
and RECORD OF DECISION
and Section 4(f) Evaluation

Submitted Pursuant to 42 U.S.C. 4332(2)(c) and 49 U.S.C. 303, and
Public Law 112-141, 126 Stat. 405, Section 1319(b)

By the
U.S. Department of Transportation
Federal Highway Administration
and
Wisconsin Department of Transportation

COOPERATING AGENCY
U.S. Army Corps of Engineers (pursuant to 33 CFR 230)

APPROVALS

10/15/18

Date

Michael Davies, P.E., Division Administrator, FHWA, Wisconsin Division

10/15/18

Date

Dave Ross, Secretary, Wisconsin Department of Transportation

CONTACTS FOR ADDITIONAL INFORMATION ABOUT THIS DOCUMENT

Michael Davies, P.E.
Division Administrator
Federal Highway Administration
525 Junction Road, Suite 8000
Madison, WI 53717-2157
(608) 829-7505

Scott Lawry, P.E.
Bureau of Technical Services, Director
Wisconsin Department of Transportation
4822 Madison Yards Way, 5th Floor
Madison, WI 53705
(608) 266-2186

ABSTRACT

Wisconsin Highway 23 is part of the National Highway System (NHS) and is a rural principal arterial that connects Fond du Lac and Sheboygan in east central Wisconsin. Both west and east ends of the project are located in the growing urban areas of Fond du Lac and Plymouth. At 19.1 miles in length, this highway corridor serves high traffic volumes near the urban areas and lower traffic volumes in rural areas. This document evaluates the No-Build Alternative and several Build Alternatives that have the option to include corridor preservation for potential future transportation improvements.

FHWA and WisDOT have prepared this Limited Scope Supplemental Final Environmental Impact Statement (LS SFEIS) in accordance with 23 Code of Federal Regulations (CFR) 771.130. This LS SFEIS is used to address issues of limited scope associated with the overall project.

This LS SFEIS identifies the Preferred Alternative that reconstructs WIS 23 to a 4-lane divided highway on the existing alignment and creates interchanges, connector roads, and a trail. The Preferred Alternative also includes corridor preservation for potential future transportation improvements.

FHWA is issuing a single LS SFEIS and Record of Decision (ROD) document pursuant to Public Law 112-141, 126 Stat. 405, Section 1319(b). As a result, the 30-day waiting period between the LS SFEIS and ROD, prescribed in 23 CFR 771.127(a) will not occur.

NATIONAL ENVIRONMENTAL POLICY ACT STATEMENT

The National Environmental Policy Act (NEPA), 42 USC 4321-4347, became effective January 1, 1970. This law requires that all federal agencies have prepared for every recommendation or report on proposals for legislation and other major federal actions significantly affecting the quality of the human environment a detailed Environmental Impact Statement (EIS). The Federal Highway Administration (FHWA) is therefore required to have prepared an EIS on proposals that are funded under its authority if the proposal is determined to be a major action significantly affecting the quality of the human environment.

EISs are required for many transportation projects as outlined in NEPA. This Limited Scope Supplemental Environmental Impact Statement (LS SEIS) follows the same procedure as an original EIS, except that scoping is not required [40 CFR 1502.9(c), 23 CFR 771.130]. The processing of the LS SEIS is carried out in two stages: draft and final. The Limited Scope Supplemental Draft EIS (LS SDEIS) is circulated for review and comment to federal, state, and local agencies with jurisdiction by law or special expertise and it is made available to the public. The LS SDEIS must be made available to the public at least 15 days before the public hearing and no later than the first public hearing notice or notice of opportunity for a hearing. A minimum 45-day comment period is provided from the date the LS SDEIS notice of availability is published in the Federal Register. Wisconsin Department of Transportation (WisDOT) must receive agency and public comments on or before the date listed on the front cover of the LS SDEIS unless a time extension is granted by the FHWA and WisDOT. After the comment period for the LS SDEIS has elapsed, preparation of the Limited Scope Supplemental Final EIS (LS SFEIS) can begin. The LS SFEIS includes:

1. Basic content of the Limited Scope Supplemental Draft Environmental Impact Statement, as amended, due to internal agency comments, editing, additional alternatives being considered, and changes due to the time lag between the Draft, Supplemental Draft, and Supplemental Final EIS.
2. Summary of public hearing environmental comments.
3. Copies of comments received on the LS SDEIS.
4. Responses to each substantive comment.
5. Resolution of environmental issues and documentation of compliance with applicable environmental laws and related requirements.

The Draft, Supplemental Draft, and Final EIS are full-disclosure documents, which provide a full description of the proposed project, the existing environment, and an analysis of the anticipated beneficial or adverse environmental effects.

A Record of Decision (ROD) is the administrative action that approves the selected alternative. The ROD presents the basis for the decision, summarizes any mitigation measures that will, or are proposed to be incorporated in the project, and documents required Section 4(f) approvals. Public Law 112-141, 126 Stat. 405, Section 1319(b) states that to the maximum extent practicable, the lead agency shall expeditiously develop a single document that consists of a FEIS and a ROD. This environmental document is a combined LS SFEIS/ROD.

The names, addresses, and telephone numbers of the individuals from whom additional information can be obtained are listed on the cover of this document.

GENERAL REVIEWER INFORMATION

A gray box provided at the beginning of each section provides an introduction to the section and describes what has changed since the 2014 LS SFEIS. Yellow highlight signifies updates since the May 2018 LS SDEIS. Minor changes to grammar, punctuation, and usage are not highlighted. Highlighting of a figure or table title signifies updated or new information.

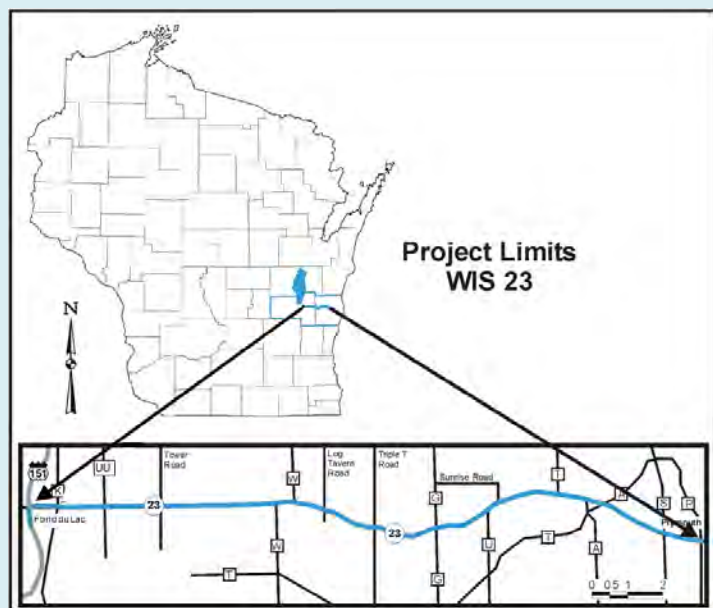

Yellow highlight signifies updates since the May 2018 Limited Scope Supplemental Draft Environmental Impact Statement (LS SDEIS). Page numbers that have changed are not highlighted.

TABLE OF CONTENTS

APPENDICES	Page No.
A Traffic Memoranda.....	A-1
Technical Memorandum: DHV for WIS 23 Evaluation	A-1
Technical Memorandum: Traffic Modeling Methodology	A-15
Attachment A: Schematic Maps of Mainline Alternatives.....	A-36
Attachment B: No-Build and Alternative Segment Length Maps	A-38
Attachment C: WIS 23 Mainline Traffic Analysis Input Worksheets.....	A-42
Attachment D: Access Density Calculations	A-50
Attachment E: No-Passing Zone Calculations	A-54
Attachment F: Projected Intersection Volumes.....	A-59
Attachment G: WisDOT BTO Peer Review	A-86
Attachment H: Traffic Operations Results	A-103
B Traffic Forecasting Memorandum	B-1
Attachment A: Forecast Calculations and Reports (NERTDM only).....	B-19
Attachment B: Forecast Calculations and Reports (TAFIS Incorporated)	B-33
Attachment C: Technical Documentation - NERTDM Version 8 and 8a.....	B-65
C Coordination	C-1
D Conceptual Stage Relocation Plan	D-1
E Indirect and Cumulative Effects Analysis	E-1
Attachment A	E-112
F WIS 23 Preferred Alternative Identification Memorandum.....	F-1

THIS PAGE INTENTIONALLY LEFT BLANK

**APPENDIX A
TRAFFIC MEMORANDA**

THIS PAGE INTENTIONALLY LEFT BLANK

Yellow highlight signifies updates since the May 2018 Limited Scope Supplemental Draft Environmental Impact Statement (LS SDEIS). These updates are related to discussion in this Memorandum and do not affect the analysis and recommendations of this Memorandum.

TECHNICAL MEMORANDUM

To: Bryan Lipke P.E. - Wisconsin Department of Transportation, Northeast Region
Jennifer Murray, AICP - Wisconsin Department of Transportation, Forecasting
Dawn Krahn, P.E. - Wisconsin Department of Transportation, Bureau of State Highway Programs

From: Thomas W. Lynch, P.E., PTOE
Joseph M. Urban, P.E.
Strand Associates, Inc.®

Date: May 11, 2018

Re: ID 1440-13/15-00
Fond du Lac to Plymouth
WIS 23
Fond du Lac and Sheboygan Counties
DHV for WIS 23 Evaluation

May 11, 2018 update: The statistical analysis and recommendations included in this memorandum were completed in September 2017 and were documented in the October 5, 2017 version of this memorandum. WisDOT reviewed and approved the recommendations in the October 5, 2017 memorandum. Updates to this memorandum have been made to reflect changes in the WisDOT FDM implemented on March 16, 2018, to reflect the date of the most current traffic forecasts (April 6, 2018) for the study, and to expand on the background section.

Background

This memorandum documents evaluation of traffic data used to develop inputs for the traffic operations analysis within the Wisconsin State Highway (WIS) 23 2018 Limited Scope Supplemental Environmental Impact Statement (LS SEIS) project limits. The study limits are the US Highway 151 (US 151)/WIS 23 interchange on the west end and County P/Pioneer Road (County P) on the east end. The corridor is mostly a 2-lane rural highway, with relatively short stretches of 4-lane highway on both ends of the corridor. The traffic analysis for this study focuses on the two-lane highway portion of the corridor from County UU to County P, which is nearly 18 miles long.

This **memorandum** focuses on a review of hourly traffic characteristics of roadways near the WIS 23 corridor and provides a recommendation for a K value and directional distribution (DD) factor to determine the Design Hour Volume (DHV). Also reviewed is traffic count data, truck percentage data, Peak Hour Factor (PHF), and the analysis software to use for the traffic analysis. More information on other traffic modeling inputs are located in the Traffic Modeling Methodology memorandum in Appendix A of the 2018 LS SEIS.

The DHV is a design criterion used to design roadway improvements with an appropriate traffic volume. The DHV was developed to promote roadway designs that provide a reasonable Level of Service (LOS) for the majority of the hours within the year. An appropriate DHV is chosen to avoid “Over Building” a roadway to accommodate traffic demands that occur only a few hours of every year.

According to the WisDOT Facilities Development Manual (FDM), Section 11-5-3.5.1.1, it is WisDOT policy to use the 30th highest hour volume (K30) as the DHV for both multilane highways and rural two-lane facilities. The FDM further states:

“There may be unique circumstances where K30 is not realistic to use because of exceptionally high hourly volume peaking characteristics. These conditions may occur on routes with a higher level of recreational traffic or routes that are in close proximity to a stadium, seasonal shopping mall or other special event traffic generator. A higher design hour may be justified when the LOS using the 30th highest hour cannot be achieved because of social and environmental constraints, or if the project is financially cost prohibitive.”

When higher design volumes are justified, the FDM states that LOS evaluation should also consider the 100th highest hour (K100) for rural or small to medium urban areas and the 200th (K200) or 250th highest hour (K250) for highly urbanized areas (>200,000 population) with heavy daily traffic but that the Federal Highway Administration (FHWA) must approve deviations from the K30 design hour on interstate projects.

In the summer of 2017, traffic counts were performed by WisDOT along the WIS 23 study corridor. However, this data does not provide yearly data for use in determining the DHV. There are two continuous count sites, or Automatic Traffic Recorders (ATRs), near the study corridor that could be considered to determine the DHV. The FDM 11-5-3.5.1.1 states:

The design hour evaluation should be made by analyzing the traffic volume data from the most applicable continuous traffic count site locations.

Figure 1 illustrates the study corridor and the two most applicable ATRs that were available to provide data regarding regional travel peaking characteristics.



Figure 1 ATRs used for Review

Methodology

The study took the following steps in its review:

1. Review 2016 ATR traffic profile data for peaking characteristics. Weekday (Monday through Thursday), Friday, and Sunday peaking characteristics are reviewed. This review helps identify the type of traffic using WIS 23, commuter, recreational, or both.
2. Review 2016 ATR data for hourly ranking. For each ATR the 30th and 100th highest hour in each direction is identified, and the corresponding non-peak direction is obtained. From these values a K value and DD is developed.
3. Provide recommendations for K value, and DD to use in the operations analysis.
4. Review hourly turning movement counts to identify the PHF that currently exists for the morning and evening peak hours.
5. Provide recommendations for which PHF to use in the operations analysis.
6. Review available truck data from roadway counts and WIS 23 ATR.
7. Provide recommendations on truck percentages to use in the operations analysis.

Area Background

The 19.1-mile WIS 23 study corridor is largely a rural corridor that connects two metropolitan urban areas, Fond du Lac and Sheboygan. The Fond du Lac core urban statistical area amounts to about 101,600 while the Sheboygan core urban statistical area amounts to 115,500.¹ I-41 is a major north-south corridor that connects the Fond du Lac area to Milwaukee and the Fox Valley and Green Bay. I-43 is a major north-south corridor that serves the Sheboygan area and connects it to Milwaukee and Green Bay. WIS 23 is one of the few, higher mobility, roadways that travel east-west through the region connecting these two interstate highways.

Peak traffic hours for I-41 and I-43 are affected by special events in Green Bay, specifically Packer games. They also provide access to summer vacation destinations in northern Wisconsin, including the Door County peninsula. WIS 23 does not provide a direct route to Green Bay and therefore Packer games probably have a more limited effect. WIS 23 provides access to the two urban areas. It also provides access to, and therefore is influenced by, recreational destinations in the Sheboygan area and Lake Michigan lakefront. These recreational areas include Kohler's Blackwolf Run golf course, Whistling Straights golf course, Kohler-Andreas state park, and Elkhart Lake Road America race track.

The two ATRs being used for this review are located on I-41 (201305) west of the corridor, and on WIS 23 (590608) east of the corridor, as shown in Figure 1.

¹ 2010 OMB Bulletin No 10-02

Hourly Volume Profile

Figure 2 illustrates the hourly volume profile for the I-41 ATR site in both the northbound and southbound directions during the summer months. The grey line shows typical commuting patterns with morning and evening rush hour peaks. The dashed orange and blue lines indicate there is a recreational component for I-41 traffic. This is illustrated by the large northbound movement on Friday evenings, and large southbound movement on Sunday afternoons.

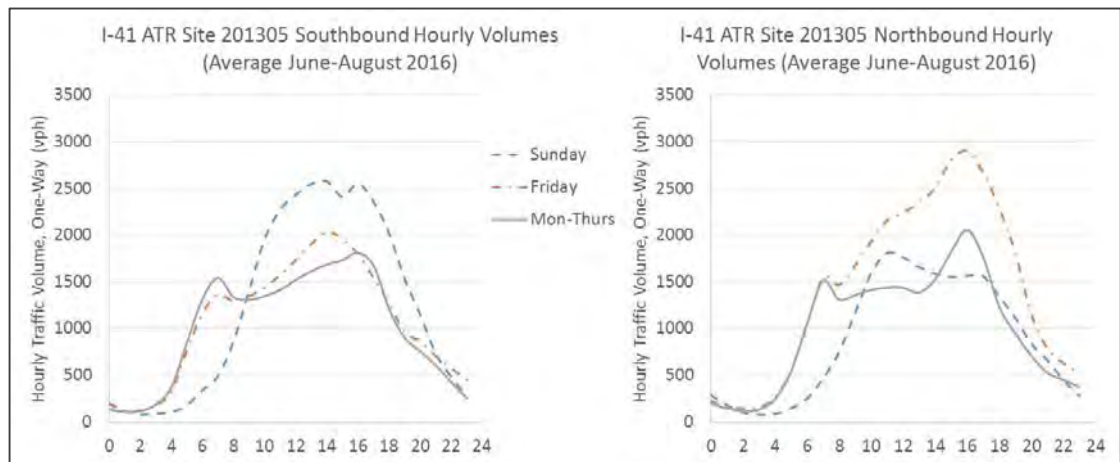

Figure 2 I-41 Traffic Volume Profile - Summer Months (ATR 201305)

Figure 3 illustrates the hourly volume profile for the WIS 23 ATR site in each direction of travel during the summer months. It has a distinctly different profile from that of the I-41 profile. The Friday profile essentially matches the profile of the weekday traffic. And the Sunday volume profile is less pronounced.

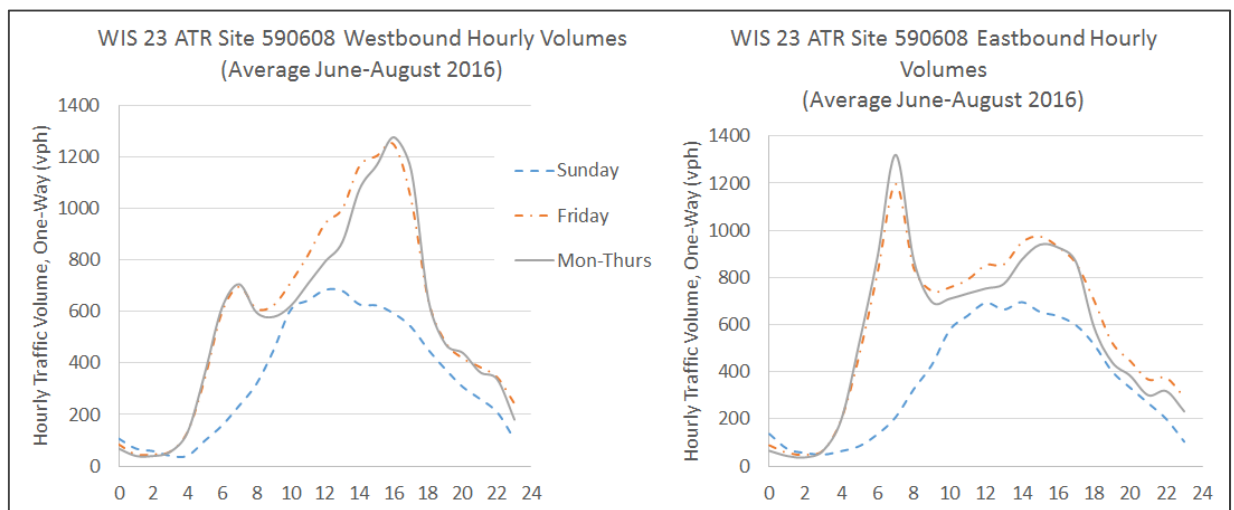

Figure 3 WIS 23 Traffic Volume Profile - Summer Months (ATR 590608)

For reasons previously stated, the study team believes that the WIS 23 ATR provides a better representation of traffic characteristics in the WIS 23 study corridor.

Hourly Volume Ranking

Three types of hourly ranking for K30 and K100 are provided for the two ATR sites. The I-41 ATR site uses 342 days of data in 2016² for analysis, with an AADT volume of 44,446 vehicles per day (vpd). The WIS 23 ATR uses 356 days of data in 2016³ for the analysis. The I-41 ATR had the following 2016 AADT:

Southbound 22,218 vpd
 Northbound 22,228 vpd
 Two-way 44,446 vpd

I -41 Northbound Peak Hours			
K30		K100	
Friday 7/1/16, 7 pm	2,929 vph NB 900 vph SB	Friday 7/1/16, 5 pm	2,552 vph NB 1,657 vph SB
Total	3,829 vph	Total	4,209 vph
Percent of NB AADT	13.18	Percent of NB AADT	11.48
Percent of two- way AADT	8.61	Percent of two- way AADT	9.47
DD	77/23	DD	61/39
Beginning of a three-day summer holiday weekend		Beginning of a three-day summer holiday weekend	
I -41 Southbound Peak Hours			
K30		K100	
Sunday 7/31/16, 12 noon	2,087 vph NB 2,814 vph SB	Monday 9/5/16, 6 pm	953 vph NB 2,404 vph SB
Total	4,901 vph	Total	3,357 vph
Percent of SB AADT	12.67	Percent of SB AADT	10.82
Percent of two- way AADT	11.03	Percent of two- way AADT	7.55
DD	57/43	DD	72/28
Packer Family Night		End of a three-day summer holiday weekend	

² Data was not available for these 2016 dates: 3/13, 4/5, 4/6, 5/27, 6/11-6/24, 9/30, 9/31, 10/1, 11/6 - 2016 was a leap year.

³ Data was not available for these 2016 dates: 1/1, 4/6, 6/7, 9/1, 12/7 - 2016 was a leap year.

I -41 Combined Peak Hours			
K30		K100	
Friday 4/29/16, 4 pm	2,729 vph NB	Sunday 8/7/16, 2 pm	1,714 vph NB
	2,221 vph SB		2,831 vph SB
Total	4,950 vph	Total	4,545 vph
Percent of two-way AADT	11.14	Percent of two-way AADT	10.23
DD	55/45	DD	62/38

The WIS 23 ATR had the following 2016 AADT:

Westbound 11,802 vpd
Eastbound 12,131 vpd
Two-way 23,933 vpd

WIS 23 Eastbound Peak Hours			
K30		K100	
Thurs 12/15/16, 7 am	1,555 vph EB	Thurs 1/28/16, 7 am	1,495 vph EB
	704 vph WB		643 vph WB
Total	2,259 vph	Total	2,138 vph
Percent of EB AADT	12.82	Percent of EB AADT	12.32
Percent of two-way AADT	9.44	Percent of two-way AADT	8.93
DD	69/31	DD	70/30
Winter Weekday		Winter Weekday	

WIS 23 Westbound Peak Hours			
K30		K100	
Sat 6/8/16, 4 pm	1,375 vph WB	Weds 4/13, 4 pm	1,325 vph WB
	896 vph EB		938 vph EB
Total	2,271 vph	Total	2,263 vph
Percent of WB AADT	11.65	Percent of WB AADT	11.23
Percent of two-way AADT	9.49	Percent of two-way AADT	9.46
DD	61/39	DD	59/41
Weekday			

WIS 23 Combined Peak Hours			
K30		K100	
Fri 12/9/16, 4 pm	1,000 vph EB 1,403 vph WB	Weds 11/16, 4 pm	1,014 vph EB 1,326 vph WB
Total	2,403 vph	Total	2,340 vph
Percent of two-way AADT	10.04	Percent of two-way AADT	9.78
DD	58/42	DD	57/43
Weekend		Weekday	

For the WIS 23 ATR, both the peak direction and the combined direction K30 and K100 values are relatively close. The peak direction K30 and K100 had a half percent or less difference. The combined direction K30 and K100 had about a quarter percent difference. Additionally, the K30 and K100 hours do not correspond with typical recreational peak periods, with most of them occurring during a weekday. This suggests that WIS 23 has travel peaking characteristics that are more typical of a commuter route than a recreational route. Figure 4 graphically shows the hourly volume ranking (combined directions) for both I-41 and WIS 23. The shape of the curves illustrates the recreational/special event peaking characteristics of I-41 and the commuter characteristics of WIS 23.

For WIS 23, the peak direction K values may not be as applicable for operations analysis as the combined K value. Two-lane operations analysis uses the non-peak directional volume as it considers opportunities to pass. Therefore, the eastbound K30 and K100 directional distribution of 69/31 percent and 70/30 percent respectively may bias the effect estimate from the two-lane analysis. Conversely, the combined K30 and K100 provide directional distributions of 58/42 percent and 57/43 percent, respectively. These values are likely to provide a better and more representative two-lane operational analysis.

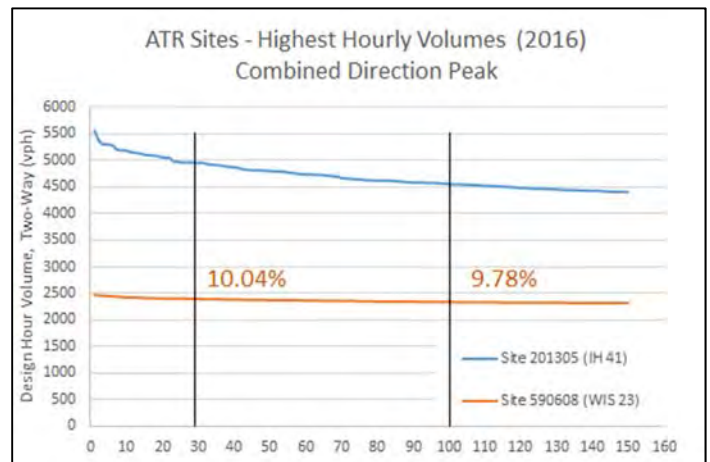

Figure 4 Peak Hour Ranking

Because the WIS 23 ATR (590608) used for the analysis is outside of the study limits, hourly volume trends from sites within the study limits were compared to the ATR hourly volume trends for similar timeframes. The study reviewed four count sites, each of which are 48-hour averages of weekdays in June 2017. ATR 590608 data from two weekdays in June 2016 was used to keep the datasets similar. The roadway counts used in this analysis are two-way volumes and were not factored or seasonally adjusted. Figure 5 shows the results of the ATR hourly volume vs. coverage count hourly volume comparison.

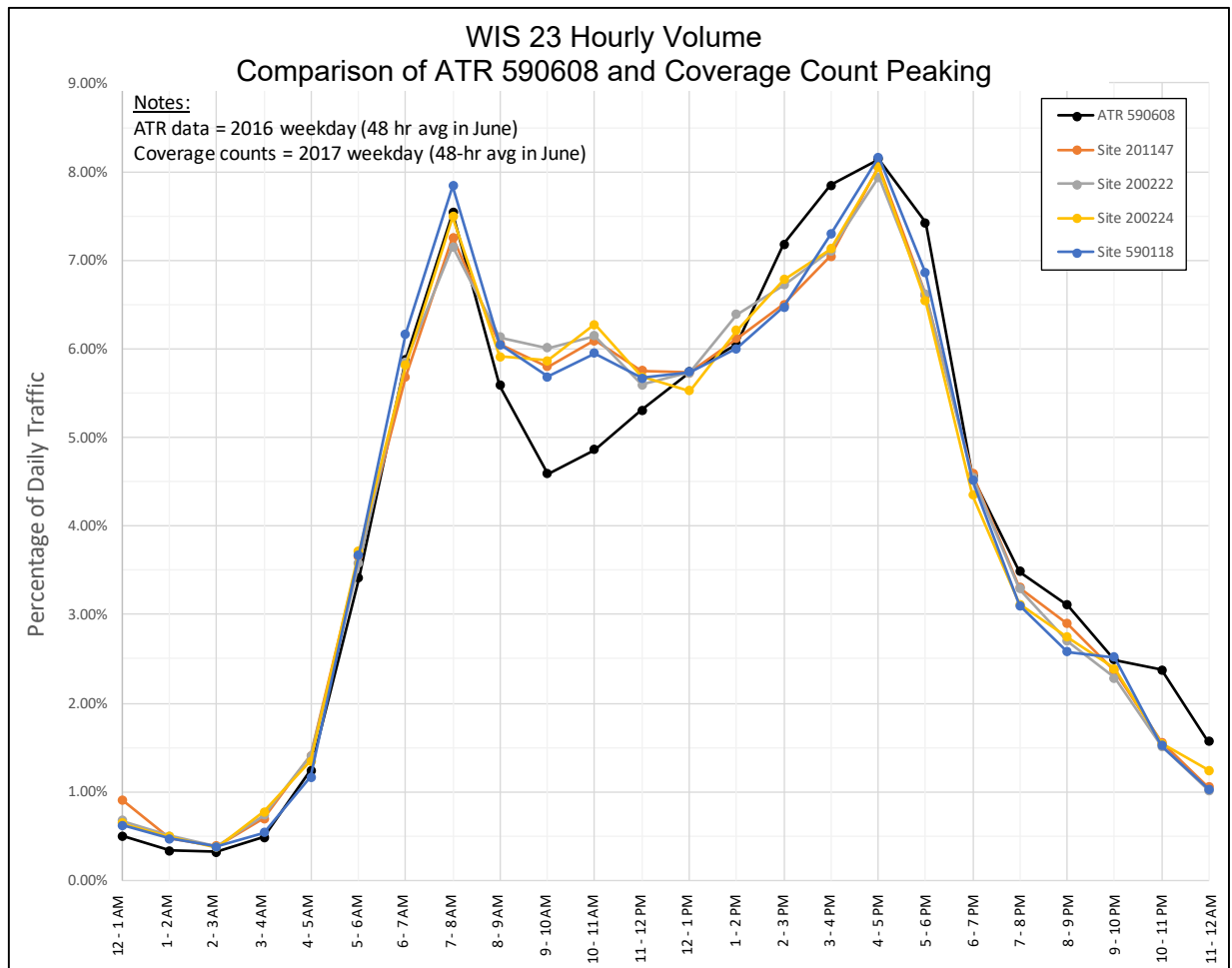

Figure 5 WIS 23 Hourly Volume, ATR vs. Coverage Counts

The results of the ATR hourly volume vs. Coverage Count (i.e. the 48-hour roadway counts performed in June 2017) hourly volume comparison show that the counts within the study corridor are similar to the ATR during peak times (7 to 8 AM and 4 to 5 PM). The ATR hourly volume has more pronounced peaking characteristics, with volumes dropping to a greater amount between 9 AM to 12 PM. However, the difference in mid-day traffic trends are less important when considering the study’s usage of the ATR data for the design hour volume. The study intends to use the ATR data to develop K30 and K100 factors for traffic analysis within the study limits. Further evaluation of the top 30 hours in terms of total roadway volume (i.e. two-way volume) revealed that 23 of the top 30 hours of 2016 occurred from 4 to 5 PM, 5 of the top 30 hours occurred from 3 to 4 PM, and 2 of the top 30 hours occurred from 7 to 8 AM. This data indicates that the ATR is a fair representation of the trends within the study limits because 25 of the top 30 hours (or 83 percent) occurred during the AM and PM peak hours.

If the ATR data was not used to develop the DHV as suggested in FDM 11-5-3.5.1.1, WisDOT forecasting developed K30 factors at three count sites based on statewide averages for the facility type.

These K30 factors were provided in the traffic forecast report dated April 6, 2018. The K30 factors at three locations in Fond du Lac County range from 10.7 percent to 12.3 percent.

This study recommends using a K30 factor of 10.0 percent based on the combined direction 2016 ATR data for the WIS 23 mainline traffic analysis.

Analysis Software

The study used Highway Capacity Software (HCS) Version 7.5 for the traffic operations analysis. This was the most current version of HCS as of April 6, 2018, when the most recent traffic forecasts were completed by WisDOT Traffic Forecasting Section. Since the initial traffic analysis in September 2017, the FDM has been updated to include HCS Version 7 as an accepted software for traffic analysis.⁴ This version of HCS follows practices from the Highway Capacity Manual (HCM) 6th edition.⁵

Traffic Counts

Traffic counts were taken by WisDOT during the summer of 2017 along the WIS 23 study corridor at 11 roadway sites and at 14 intersections. A summary of where and when the roadway counts were taken is shown in the table below.

Location: West to East			Count Data		
County	Site ID	Roadways	Count Length	Count Dates (2017)	Truck data?
Fond du Lac	201185	Wisc American - County K	48 hr	5/08 - 5/10	Yes
	200219	East of County K	48 hr	7/25 - 7/27	No
	201147	County UU - Taft	48 hr	6/27 - 6/29	Yes
	206104	West of County W (S)	48 hr	6/27 - 6/29	Yes
	200222	West of County W (N)	48 hr	6/27 - 6/29	Yes
	200224	Triple T - Hillview	48 hr	6/27 - 6/29	Yes
	201153	West of County G	24 hr	6/27 - 6/28	Yes
Sheboygan	590118	Division - Chickadee	48 hr	6/27 - 6/29	Yes
	591421	County T (S) - Sugarbush	48 hr	6/26 - 6/28	No
	591422	County A - Plank	48 hr	6/26 - 6/28	No
	590195	West of County P	48 hr	7/17 - 7/19	No

Peak period intersection traffic counts were performed in July and August 2017. The intersection counts were performed from 6 to 9 AM and 3 to 6 PM at each location. More information on how the intersection counts were used in the traffic operations analysis is located in the Traffic Modeling Methodology memorandum in Appendix A of the 2018 LS SEIS.

Truck Percentages

In order to determine a truck percentage value to use in the traffic analysis, the study analyzed available truck volume data at the summer 2017 roadway count sites throughout the study corridor and the 2016 ATR 590608 count site along WIS 23. Within the two-lane portion of the study limits (just west of County UU to County P), truck data was available at five sites in Fond du Lac County and at one site in

⁴ FDM 11-5-3.7.1.1: <http://wisconsin.gov/Pages/doing-bus/eng-consultants/cnslt-rsrcs/rdwy/fdm.aspx>, accessed March 26, 2018

⁵ Highway Capacity Manual (Transportation Research board, 6th Edition, 2016)

Sheboygan County. The study analyzed AM peak hour, PM peak hour, and daily truck volumes and truck percentages at each of these sites. The results of this analysis are shown below.

Location: West to East			A	B	C	D	E	F	G
			Truck Volume Information Data (Two-way)						
County	Site ID	Roadways	7-8 AM Truck Vol	7-8 AM Truck %	4-5 PM Truck Vol	4-5 PM Truck %	Total Daily Traffic	Daily Truck Vol	Daily Truck %
Fond du Lac	201185	Wisc Am - County K	120	8.5%	88	7.2%	14,482	1,616	11.2%
	201147	County UU - Taft	127	21.8%	105	16.3%	8,013	1,818	22.7%
	206104	West of County W (S)	144	25.3%	119	18.6%	7,937	2,040	25.7%
	200222	West of County W (N)	133	23.2%	114	17.9%	8,009	1,864	23.3%
	200224	Triple T - Hillview	149	26.6%	97	16.1%	7,488	1,888	25.2%
	201153	West of County G	131	23.8%	101	17.6%	7,065	1,730	24.5%
Sheboygan	590118	Division - Chickadee	119	21.4%	76	13.1%	7,133	1,546	21.7%
	590608 (ATR)	East of WIS 32	111	5.5%	89	4.1%	26,544	1,732	6.5%

Columns A-G represent averages of the available count data (typically a 48-hour period btwn Tues and Thurs).

Columns A-G volume data is not seasonally adjusted and is being used here for vehicle classification purposes.

The analysis shows that the amount of truck traffic from Wisconsin American Drive to east of WIS 32 remains relatively consistent during the AM and PM peak hours. There are fluctuations with daily truck traffic. While the truck volumes are consistent, the truck percentages are lower in the 4-lane sections (Wisconsin American Drive to County K and east of WIS 32) because of the relatively consistent number of trucks, yet higher amount of passenger vehicles at these locations (as shown in Columns E and F of the table above). Daily truck volumes are not used directly in the operations analysis, but provide an overall picture of the mix of traffic along the study corridor.

As mentioned earlier, 23 of the top 30 two-way hourly volumes at ATR 590608 occurred during the PM peak hour (4 to 5 PM) in 2016 and another 5 of the top 30 two-way hourly volumes occurred during the hour before the PM peak hour (3 to 4 PM). For this reason, the study proposes to use the weighted average PM peak hour truck percentages from the field data between County UU and County G for analysis in Fond du Lac County and the truck percentage from **roadway count** Site 590118 for analysis in Sheboygan County. These values correspond to 17.4 percent for Fond du Lac County and 13.1 percent for Sheboygan County. Because HCS software only accepts rounded truck percentage values, the study used 17.0 percent for Fond du Lac County and 13.0 percent for Sheboygan County, in the peak hour traffic operations analysis. See the Traffic Modeling Methodology memorandum in Appendix A of the 2018 LS SEIS for more information on how these truck percentages were applied in the traffic operations analysis.

Peak Hour Factor

The PHF is the hourly volume during the maximum-volume hour of the day divided by the peak 15-minute flow rate within the peak hour; a measure of traffic demand fluctuations within the peak hour. PHF is used in operational analysis to account for the volume fluctuations during a typical rush hour. In rural areas a typical PHF is 0.88 based on default values provided in Chapter 15 of the HCM 6th edition. In urban or more saturated conditions, a PHF can be 0.92 or greater. The FDM 3.5.2.1 policy for PHF on Facility Segments states:

The PHF for the existing conditions can be based on existing field data. If field data does not exist, the recommended HCM default can be used. For design year conditions use a PHF of 1.0.

This policy accounts for the flattening of volume variation within the design hour that occurs as traffic increases and roadways become more congested in the design year. For a highway like WIS 23 that is not saturated, the policy may mute the actual peak hour variations that are likely to occur, even with traffic growth. For this reason, the study performed a sensitivity analysis of the operations results by varying the PHF from the current WisDOT policy. To determine the PHF to use in the sensitivity analysis, the study used peak hour counts that were performed by WisDOT at the majority of intersections along WIS 23 during the summer 2017. While the PHF for each leg of an intersection is important for intersection analysis, the PHF for the WIS 23 mainline is most important for the WIS 23 mainline sensitivity analysis. The following table shows an average WIS 23 PHF of 0.87 for the AM **peak** hour and of 0.89 for the PM **peak** hour. These values represent higher volume variations during the peak hour.

Location	AM Peak Hour					PM Peak Hour				
	SB	WB	NB	EB	Int	SB	WB	NB	EB	Int
WIS 23 & County UU	0.56	0.94	0.68	0.85	0.92	0.50	0.85	0.72	0.91	0.92
WIS 23 & County S	0.25	0.90	0.65	0.80	0.89	0.50	0.86	0.67	0.83	0.85
WIS 23 & Sugarbush Road	0.69	0.92	0.31	0.81	0.87	0.25	0.80	0.50	0.92	0.89
WIS 23 & County A	0.81	0.88	0.61	0.88	0.91	0.65	0.83	0.66	0.95	0.94
WIS 23 & 7 Hills Road	0.67	0.85	0.79	0.86	0.89	0.75	0.88	0.62	0.84	0.90
WIS 23 & American Drive	0.00	0.95	0.57	0.89	0.92	0.00	0.91	0.95	0.93	0.97
WIS 23 & County G	0.94	0.79	0.87	0.95	0.89	0.67	0.94	0.74	0.92	0.94
WIS 23 & County K	0.79	0.97	0.75	0.83	0.91	0.69	0.88	0.71	0.89	0.93
WIS 23 & County U	0.00	0.93	0.70	0.78	0.87	0.00	0.88	0.67	0.90	0.89
WIS 23 & County W/Hinn Road	0.75	0.84	0.81	0.89	0.87	0.37	0.91	0.82	0.92	0.91
WIS 23 & County W/Loehr Road	0.87	0.87	0.67	0.94	0.91	0.78	0.95	0.75	0.88	0.94
WIS 23 & Hillview Road	0.50	0.80	0.50	0.93	0.90	0.50	0.93	0.56	0.87	0.89
WIS 23 & Tower Road	0.52	0.87	0.37	0.82	0.92	0.71	0.94	0.58	0.90	0.91
WIS 23 & Scenic View Road	0.75	0.84	0.00	0.83	0.88	0.50	0.83	0.25	0.89	0.86
Average		0.881		0.863	0.897		0.886		0.897	0.911
		Mainline Average PHF (rounded) = 0.87					Mainline Average PHF (rounded) = 0.89			

As mentioned earlier, 23 of the top 30 two-way hourly volumes at ATR 590608 occurred during the PM peak hour (4 to 5 PM) in 2016 and another 5 of the top 30 two-way hourly volumes occurred during the hour before the PM peak hour (3 to 4 PM). For this reason, the study used the average mainline PM peak hour PHF of 0.89 from the field data in the sensitivity analysis.

K and Peak Hour Factor Sensitivity Analysis

As mentioned, the WIS 23 ATR provides traffic data patterns that best reflect the traffic on the study corridor. Several design hour (K), PHF, and DD combinations were reviewed to see how they would affect the volumes used in the operations analysis. These variables include:

- Using peak K30 for each direction of WIS 23.
- Using K30 for the combined WIS 23 (i.e. both directions of travel).
- Using peak K100 for each direction of WIS 23.
- Using K100 for the combined WIS 23.
- Using PHF of 1.0 per current policy.
- Using measured PHF of 0.89.

Operational analyses are performed for the peak 15 minutes of the peak hour. The following table illustrates the volumes that could be used in the operational analysis using the following assumptions.

1. Using the K30 WB design hour and corresponding EB hour, PHF of 1.0
 Using the K30 EB design hour and corresponding WB hour, PHF of 1.0
2. Using the combined K30 design hour, DD of 58/42, PHF of 1.0
3. Using K100 WB design hour and corresponding EB hour, PHF of 0.89
 Using K100 EB design hour and corresponding WB hour, PHF of 0.89
4. Using combined K100 hour, DD of 57/43, PHF of 0.89

The following table illustrates the 15-minute peak volume that would be used with each option. Note that the example volumes used in this table were not used directly in the WIS 23 operations analysis.

Analysis Options	Direction	AADT	K Factor	DD	PHF	DHV*	15-min Peak
Option 1 K30 EB and WB PHF = 1.0	EB	12,131	12.82%	69	1.00	1,555	389
	WB			31	1.00	704	198
	Total					2,259	587
	WB	11,802	11.65%	61	1.00	1,375	344
	EB			39	1.00	896	252
	Total	--	--	--		2,271	596
Option 2 K30 Two-Way PHF = 1.0	EB	--	--	58	1.00	1,394	348
	WB	--	--	42	1.00	1,009	252
	Total	23,933	10.04%			2,403	601
Option 3 K100 EB and WB PHF 0.89	EB	12,131	12.32%	70	0.89	1,495	420
	WB			30		643	181
	Total					2,138	600
	WB	11,802	11.23%	59	0.89	1,325	372
	EB			41		938	263
	Total	--	--	--		2,263	636
Option 4 K100 Two-Way PHF 0.89	EB	--	--	57	0.89	1,334	375
	WB	--	--	43	0.89	1,006	283
	Total	23,933	9.78%			2,341	658

*Directional DHV Calculation (Options 1 and 3) = $AADT \times K \text{ Factor} / \text{Existing PHF}$
 Existing PHF = 0.89
 PHF = Hourly Volume / (4 x Peak 15-minute Volume)

Summary

Design Hour Volume (K) and Directional Distribution (DD)

The study used the combined K30 factor and the corresponding combined roadway DD of 58/42 for the operations analysis. Reasons for this include the following:

- WIS 23 exhibits peaking patterns that are characteristic of a commuter route. The difference between the K30 and K100 is only a quarter of a percent. Using the K30, as per policy, will not produce peak hour volumes that are unduly influenced (i.e. higher) by special events or recreational traffic.
- The combined K30 produced more balanced DD than the single direction K30 values. In two-lane roadway analysis the non-peak direction influences the LOS. Determining the DD through analyzing single-direction K factors produced unreasonable DD splits. This occurred for the EB direction of travel where the DD for K30 and K100 was closer to 70/30 and was during the AM peak hour. Whereas the combined K30 provided a DD of 58/42, which is more balanced and will provide better two-lane operations analysis.

Peak Hour Factor

The study performed mainline operations analysis using a PHF of 0.89 and 1.0. The operations analysis using a PHF of 1.0 is per WisDOT policy and assumes no variations in demand over the peak hour in the design year. These results were used directly in the body of the 2018 LS SEIS.

An operations sensitivity analysis using a PHF of 0.89 was performed to compare WIS 23's future operation with its existing operation assuming no variations in demand over the peak hour in the design year. These results are included in the Traffic Modeling Methodology memorandum located in Appendix A of the 2018 LS SEIS.

Truck Percentages

The study used a peak hour truck percentage of 17 percent for Fond du Lac County mainline analysis and 13 percent for Sheboygan County mainline analysis. These values are consistent with the peak hour truck percentages obtained from the summer 2017 traffic counts. Because WIS 23 is a commuter route with relatively little difference between K30, K100, and K250, the count site truck percentages provide a reasonable representation of trucks during the K30 design hour. Daily truck volumes along the 2-lane portion of the study corridor range from 22 to 26 percent, but are not used directly in the operations analysis.

Analysis Software

The study used HCS Version 7.5. The Traffic Modeling Methodology memorandum includes discussion on software inputs, assumptions, and the use of the traffic forecasts in the analysis. HCS Version 7 is an accepted WisDOT HCM-Based Deterministic Tool per WisDOT FDM 11-5-3.7.1.1. This separate memorandum is included in Appendix A of the 2018 LS SEIS.

Summary

A summary of the factors that will be used in the WIS 23 mainline operations analysis is below.

K30 = 10.0%

DD = 58/42

Bryan Lipke
Wisconsin Department of Transportation, Northeast Region
ID 1440-13/15-00
Page 14
May 11, 2018

PHF = 1.00, and a PHF = 0.89 as a sensitivity analysis to compare with existing conditions
Mainline truck percentage (Fond du Lac County) = 17.0%
Mainline truck percentage (Sheboygan County) = 13.0%
Analysis Software: HCS Version 7.5

Yellow highlight signifies updates since the May 2018 Limited Scope Supplemental Draft Environmental Impact Statement (LS SDEIS). These updates are related to discussion in this Memorandum and do not affect the analysis and recommendations of this Memorandum.

TECHNICAL MEMORANDUM

To: Bryan Lipke P.E. - Wisconsin Department of Transportation, Northeast Region
Dawn Krahn, P.E. - Wisconsin Department of Transportation, Bureau of State Highway Programs
Ben Rouleau - Wisconsin Department of Transportation, Bureau of Traffic Operations

From: Thomas W. Lynch, P.E., PTOE
Joseph M. Urban, P.E.
Strand Associates, Inc.®

Date: May 11, 2018

Re: ID 1440-13/15-00
Fond du Lac to Plymouth
WIS 23
Fond du Lac and Sheboygan Counties
Traffic Modeling Methodology

Section 1: Background

This memorandum documents the traffic analysis software and methodology used for traffic modeling within the Wisconsin State Highway (WIS 23) 2018 Limited Scope Supplemental Environmental Impact Statement (LS SEIS) project limits. The study limits are the US Highway 151 (US 151)/WIS 23 interchange on the west end and County P/Pioneer Road (County P) on the east end. The corridor is mostly a 2-lane rural highway, with relatively short stretches of 4-lane highway on both ends of the corridor. The traffic analysis for this study focuses on the two-lane highway portion of the corridor from County UU to County P, which is nearly 18 miles long. Figure 1 shows the study limits and sections of two-lane and four-lane mainline within the study limits.

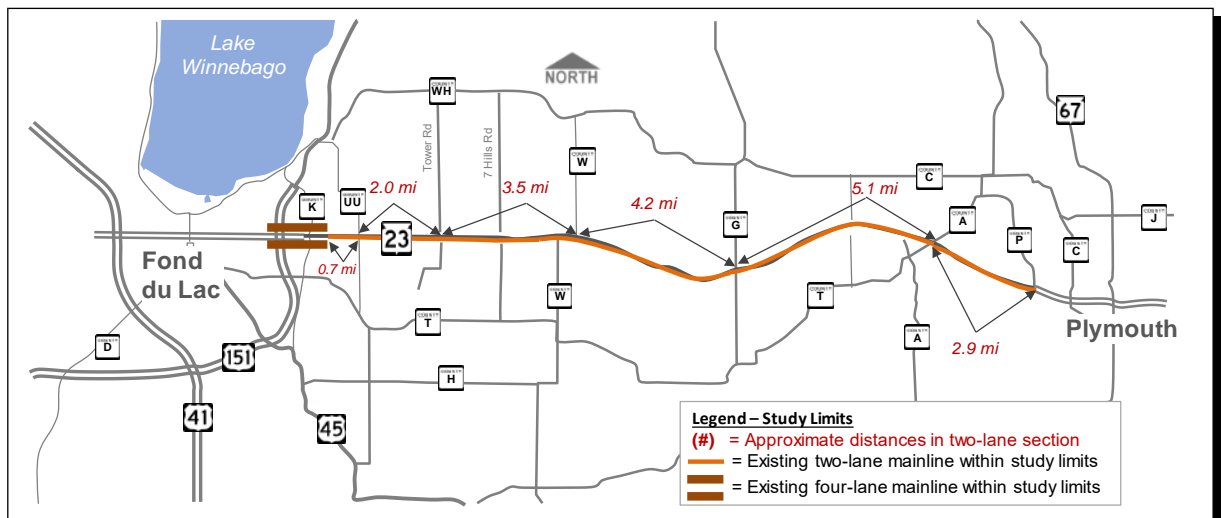

Figure 1 WIS 23 Study Limits

Bryan Lipke
Wisconsin Department of Transportation, Northeast Region
ID 1440-13/15-00
Page 2
May 11, 2018

The alternatives being considered for this study will require the following types of traffic analyses:

1. Two-lane highway analysis
2. Interchange segment analysis
3. Intersection analysis

There are no traffic signal or roundabout-controlled intersections within the existing study corridor and none are proposed along the WIS 23 mainline as part of this study. Roundabout-controlled intersections are included at the ramp terminals for proposed interchanges.

Further information on the alternatives being considered can be found in Section 2 of the 2018 LS SEIS. Schematic maps displaying the alternatives are shown in Attachment A of this memorandum.

Roadway and intersection traffic counts were performed in the summer of 2017 along the study corridor. Traffic forecasts were prepared by Wisconsin Department of Transportation (WisDOT) Traffic Forecasting Section (TFS) on April 6, 2018 using the 2017 count data as the existing conditions, or base year, and 2040 as the design year. The development and results of the traffic forecasts are presented in the traffic forecasting memorandum prepared by WisDOT TFS included in Appendix B of the 2018 LS SEIS.

Mainline traffic forecasts were prepared at 11 locations along the WIS 23 mainline throughout the study corridor for each alternative. Intersection traffic counts were performed for a majority of the corridor's higher-volume intersections. During preliminary design this data was used for intersection turning movement forecasts at select locations that efficiently allowed for comparisons of the detailed intersection operations across a range of alternatives featured in the 2018 LS SEIS. In the next phase of the project, which is final design, the majority of the remaining locations that had intersection traffic counts performed will have turning movement forecasts and detailed operations analysis prepared for the selected alternative. See Section 5 of this memorandum for more detail on the intersection operations analysis.

Section 2: Traffic Analysis Software Selection

According to the WisDOT Facilities Development Manual (FDM), Section 11-5-3.7.3¹, WisDOT prefers the use of Highway Capacity Manual 6th edition² (HCM) based analysis methods for most traffic studies. The policy states “The methodologies of the HCM should be the primary way of determining the performance measures required for a variety of traffic study projects reviewed and/or commissioned by WisDOT”.

Per WisDOT FDM 11-5-3.7.1.1, the supported programs that implement the HCM methodology for capacity analysis are Highway Capacity Software 7 (HCS) - Version 7, Synchro Version 10, and SIDRA Intersection Version 7 (for roundabouts only).

1. Two-Lane Highway Analysis

a. HCM Definition

Two-lane highway analysis is appropriate for the WIS 23 corridor because the study limits consist primarily of two-lane highway (County UU to County P) and there is uninterrupted flow throughout the two-lane portion of the corridor (i.e. no traffic signals, roundabouts, or all-way-stop-controlled intersections). The HCM defines uninterrupted flow as “where there are no traffic control devices that interrupt traffic and where no platoons are formed by upstream traffic signals” (HCM 6th edition 15-1). Furthermore, the HCM states that generally any segment that is 2.0 to 3.0 miles away from the nearest signalized intersection may be considered as an uninterrupted flow segment.

For WIS 23, the nearest signalized intersection to the west of the two-lane study limits are the US 151 ramp terminal intersections, nearly 2 miles west of County UU, and to the east of the two-lane study limits (County P) the nearest signal is over 13 miles away. Because there are no traffic control devices within the two-lane study limits and that signals are far enough away to minimize platooning, two-lane highway analysis is the most appropriate methodology to analyze the mainline operations for WIS 23.

b. Software Selection

WisDOT currently supports HCS and PTV Vissim (a microsimulation program) for two-lane highway analysis, per WisDOT FDM 11-5-3.7.3.11. Because HCS directly implements the HCM methodology for capacity analysis it is more appropriate to use for the two-lane highway analysis than PTV Vissim, which is a form of microscopic traffic simulation software (microsimulation). Microsimulation tools typically require significantly more traffic data, time, and effort for calibration than HCM-based analysis tools, such as HCS, and are not considered necessary for the WIS 23 traffic analysis. HCS also has the ability to model passing lanes using methods directly from the HCM.

¹ FDM source: <http://wisconsin.gov/Pages/doing-bus/eng-consultants/cnslt-rsrcs/rdwy/fdm.aspx>, accessed March 26, 2018

² Highway Capacity Manual (Transportation Research Board, 6th Edition, 2016)

The HCM states on Page 15-11 that there are currently no other alternative deterministic tools (outside of the HCM methodology implemented by HCS) that are in common use for two-lane highway analysis.

For these reasons, the study team used HCS for the two-lane highway analysis.

2. Four-Lane Highway and Interchange Segment Analysis

Similar to the two-lane analysis, HCS is also supported by WisDOT for four-lane highway and interchange analysis per WisDOT FDM 11-5-3.7.3.9. Portions of the proposed alternatives for this study will include merge, diverge, and basic segments.

For consistency in software with the two-lane highway analysis, the study team used HCS for modeling of proposed four-lane highway and interchange segments.

3. Stop-Controlled Intersection Analysis

For stop-controlled intersection analysis the WisDOT FDM indicates in section 3.7.3.2 that HCS, Synchro, and PTV Vissim are supported WisDOT software. Both HCS and Synchro are HCM-based tools that could be used for WIS 23.

For consistency in software with the two-lane highway, four-lane highway, and interchange merge/diverge analyses, the study team used HCS for modeling of existing and proposed stop-controlled intersections.

The study team used HCS Version 7.5 in each of the traffic analyses discussed above. This was the most current version of HCS as of April 6, 2018, when the most recent traffic forecasts for the study were completed by the WisDOT TFS. This version of HCS follows practices from the HCM 6th edition.

Section 3: Two-Lane Highway Analysis

Table 1 shows the different inputs and/or assumptions used in the two-lane highway HCS analysis.

Category	WIS 23 HCS Input Value	Source
Analysis Direction Volume (or DDHV)	Weighted Average AADT x K30 x DD	FDM 11-5-3.5.1.1 Design Hour Volume for Freeways, Multilane Highways, and Two-Lane Highways
Opposing Direction Volume	Weighted Average AADT x K30 x (1 - DD)	
Shoulder Width	No-Build = 8 ft Build Alts (Passing Lanes) = 8 ft	Field conditions and proposed Build conditions
Lane Width	No-Build and Build Alts = 12 ft	Field conditions and proposed Build conditions.
Segment Length	County UU to County G = 9.8 mi County G to County P = 8.0 mi (analyzed length is slightly less) Varying lengths for passing lanes Alts	Base and No-Build: Field conditions. Passing lane effective lengths: HCM 6th Edition (15-31)
Highway Type	Class I Highway	HCM 6th Edition (15-4)
Terrain	Varies between Level and Rolling	FDM 11-5-3.5.5 Rural Roadway Conditions. See "Terrain Type" section below for more information.
Peak Hour Factor	Existing = 0.89 2040 = 1.0 per WisDOT policy and 2040 = 0.89 to compare with existing conditions	"DHV for WIS 23 Evaluation" Memo (originally dated 10/5/2017, finalized 5/11/2018)
Truck and Bus Percentage	Fond du Lac County = 17.0% Sheboygan County = 13.0% Weighted average truck percentages used for overlapping Passing Lane segments	
Recreational Vehicle Percentage	0%	Recreational vehicle volumes not separated in field data.
Access Points	Varies	See Table 6 and exhibits in Attachment D.
Mainline base free-flow speed	60 mph	Assumed to be posted +5 mph, or equivalent to a typical design speed for a highway posted at 55 mph.
No-Passing Zone Percentages	Varies	Measured from field, see Table 7 and Attachment E.

DDHV = Directional Design Hour Volume, AADT = Average Annual Daily Traffic Volume, DD = Directional Distribution

Table 1: Inputs and Assumptions for HCS Two-Lane Analysis

The following describes the factors and assumptions in the traffic analysis shown in Table 1 where further detail is beneficial.

1. Analysis Direction Volume and Opposing Direction Volume

The analysis direction (i.e. the higher-volume direction of travel) and the opposing direction volume were determined for each analysis section using a weighted Average Annual Daily Traffic (AADT) volume derived from traffic forecasts provided by WisDOT TFS. Mainline AADT volumes were provided by WisDOT TFS on April 6, 2018 for base year (2017), design year (2040) conditions, and two future interim year (2020 and 2030) conditions.

Mainline traffic forecast volumes were provided at 11 locations along the study corridor between US 151 and County P. Of the 11 sites, 9 sites are located within the 2-lane highway section of WIS 23 between County UU and County P and 2 sites are located in the 4-lane highway section of WIS 23 between US 151 and Whispering Springs Drive (~2/3 of a mile west of County UU). For the purposes of the two-lane highway operations analysis, the 9 sites located within the 2-lane section of WIS 23 are used to determine the weighted average analysis volumes.

The base conditions and 2040 No-Build analyses are broken up into two sections, County UU to County G (mostly in Fond du Lac County) and County G to County P (mostly in Sheboygan County). The analyses are divided because 2017 volumes are slightly higher east of County G. The steps to determine the weighted average volume for each analysis section are as follows:

- a. Step 1: Calculate Weighted Average AADT Volume (Two-way traffic).
- b. Step 2: Determine Two-Way Design Hour Volume (DHV). This is calculated by applying the K30 factor of 10.0% to the Weighted Average AADT Volume.
- c. Step 3: Apply Directional Distribution (DD) factor of 58% to the Two-Way DHV to determine the Analysis Direction Volume.
- d. Step 4: Apply (1 - DD) factor of 42% to the Two-Way DHV to determine the Opposing Direction Volume.

Table 2 and Figure 2 show a breakdown of the 11 WIS 23 mainline count locations in 2017 where traffic forecasts were provided.

Site ID (West to East)	2017 WIS 23 Mainline Count Location	Roadway Limits AADT Applied to in WIS 23 Two-Lane Traffic Analysis	Approximate Distance (mi) <i>Rounded to nearest hundredth</i>
201185	Wisconsin American Drive to County K	Not used - within 4-lane section	---
201022	East of County K	Not used - within 4-lane section	---
201147	County UU to Taft Road	County UU to Tower Road	1.99
206104	West of County W (south)	Tower Road to County W (south)/Hinn Road	3.03
200222	West of County W (north)	County W (south)/Hinn Road to County W (north)/Loehr Road	0.49
200224	Triple T to Hillview	County W (north)/Loehr Road to Hillview Road	3.22
201153	West of County G	Hillview Road to County G	1.03
Fond du Lac County (County UU to County G) Subtotal			9.75
590118	Division - Chickadee	County G to County T (north)	3.71
591421	County T (south) to Sugarbush	County T (north) to County A	1.41
591422	County A to Plank	County A to County S	1.84
590195	West of County P	County S to County P	1.05
Sheboygan County (County G to County P) Subtotal			8.01

Table 2: WIS 23 Mainline Count Locations and Forecast Sites

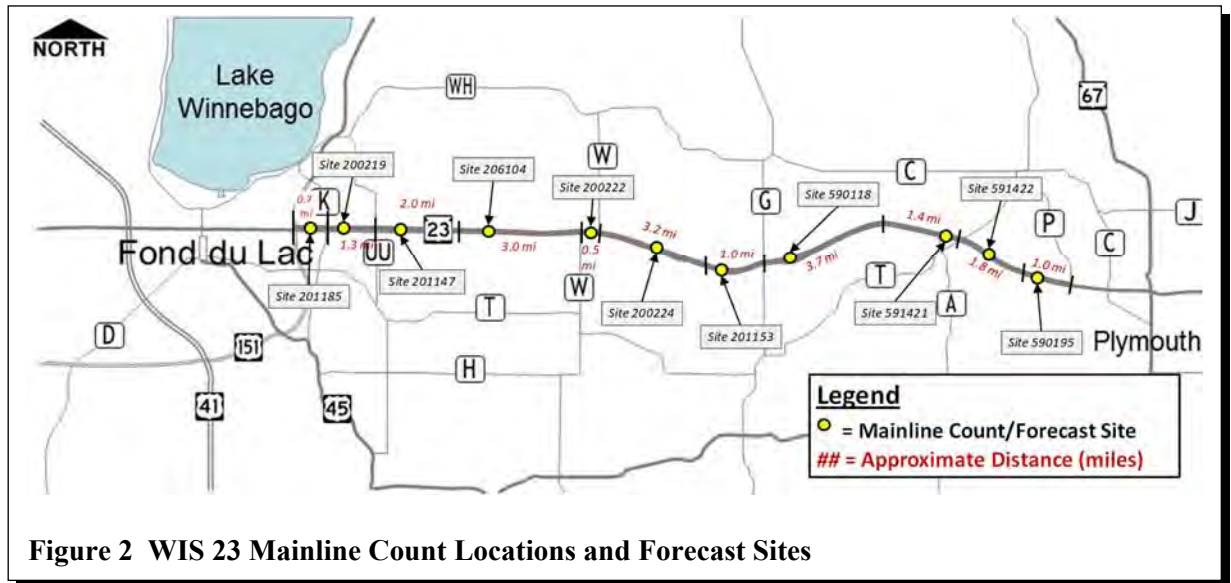

Table 3 shows a breakdown of the base conditions (2017) and projected 2040 No-Build AADT volumes at each of the WIS 23 mainline sites within the two-lane highway analysis sections.

Site ID (West to East)	Roadway Limits	Approximate Distance (mi)	2017 Count AADT	2040 No-Build AADT
201147	County UU to Taft Road	1.99	7,400	8,300
206104	West of County W (south)	3.03	7,300	7,900
200222	West of County W (north)	0.49	7,400	7,800
200224	Triple T to Hillview	3.22	6,900	7,100
201153	West of County G	1.03	6,800	6,900
County UU to County G Weighted Average AADT			7,140	7,610
590118	Division - Chickadee	3.71	6,700	6,800
591421	County T (south) to Sugarbush	1.41	7,800	7,900
591422	County A to Plank	1.84	8,400	8,700
590195	West of County P	1.05	9,400	9,700
County G to County P Weighted Average AADT			7,640	7,810

Table 3: WIS 23 Mainline 2017 and 2040 No-Build AADT Volumes

The weighted average AADT volumes shown in Table 3 are calculated by the following equation:

$$\text{Weighted Average AADT} = \frac{(\text{Length 1} \times \text{AADT 1}) + (\text{Length 2} \times \text{AADT 2}) + \dots}{\text{Total Length}}$$

An example calculation for the County UU to County G weighted average AADT volume in the 2040 No-Build Alternative is shown in the formula below:

$$\text{Weighted Average AADT} = \frac{[(1.99 \times 8,300) + (3.03 \times 7,900) + (0.49 \times 7,800) + (3.22 \times 7,100) + (1.03 \times 6,900)]}{9.75}$$

$$\text{Weighted Average AADT} = 7,610 \text{ vpd}$$

It should be noted that the calculations above are performed in a spreadsheet, where the individual section lengths in the Weighted Average AADT volume calculations are not rounded. The spreadsheet calculation provides a volume of 7,607.09 vehicles per day (vpd), which is rounded to the nearest ten at 7,610 vpd. This may lead to relatively minor differences if comparing values hand-calculated based on the information in this memo and spreadsheet values; however, the spreadsheet calculations are being used in the traffic analysis as they provide a more exact and appropriate evaluation of the weighted average AADT volumes.

Using the weighted average AADT volumes for each analysis section, the Two-Way DHV, Analysis Direction Volume and Opposing Direction Volume can be calculated with units of vehicles per hour (vph). Table 4 shows each of these values for the 2040 No-Build analysis sections. The analysis sections involving climbing lanes are discussed further in the next section.

Analysis Section	2017 Count Weighted Average AADT (vpd)	2040 No-Build Weighted Average AADT (vpd)	2040 No-Build Two-Way DHV (vph) ^[1]	2040 No-Build Analysis Direction Volume (vph) ^[2]	2040 No-Build Opposing Direction Volume (vph) ^[3]
EB/WB: County UU to County G	7,140	7,610	761	441	320
EB: County G to Climbing Lane	7,140	7,260	726	421	305
EB: County G to west of County P	7,570	7,740	774	449	325
WB: Climbing Lane	8,910	9,210	921	534	387
WB: Climbing Lane to County G	7,290	7,430	743	431	312

[1] Two-way DHV = Weighted Average AADT x K30 Factor

[2] Analysis Direction Volume = Two-Way DHV x DD Factor

[3] Opposing Direction Volume = Two-Way DHV x (1.0 - DD Factor)

Note: K30 Factor = 10.0%, DD = 58%

Table 4: WIS 23 Mainline 2040 No-Build Analysis Volumes

Example calculations for the County UU to County G 2040 No-Build Two-Way DHV, Analysis Direction Volume, and Opposing Direction Volume are shown below:

$$\begin{aligned} \text{Two-way DHV} &= 7,610 \text{ vpd} \times 0.10 = 761 \text{ vph} \\ \text{Analysis Direction Volume} &= 761 \text{ vpd} \times 0.58 = 441 \text{ vph} \\ \text{Opposing Direction Volume} &= 761 \text{ vpd} \times (1 - 0.58) = 320 \text{ vph} \end{aligned}$$

The Analysis Direction Volume and Opposing Direction Volume values are directly input into HCS for the two-lane highway operations analysis.

2. Analysis Section Length

For the two-lane highway analysis for the No-Build conditions and for the with passing lanes analysis, effective lengths of the passing lanes and/or climbing lanes need to be calculated. Figure 3 shows the locations of the proposed passing lanes for the Passing Lane Alternative and the locations of the existing climbing lanes.

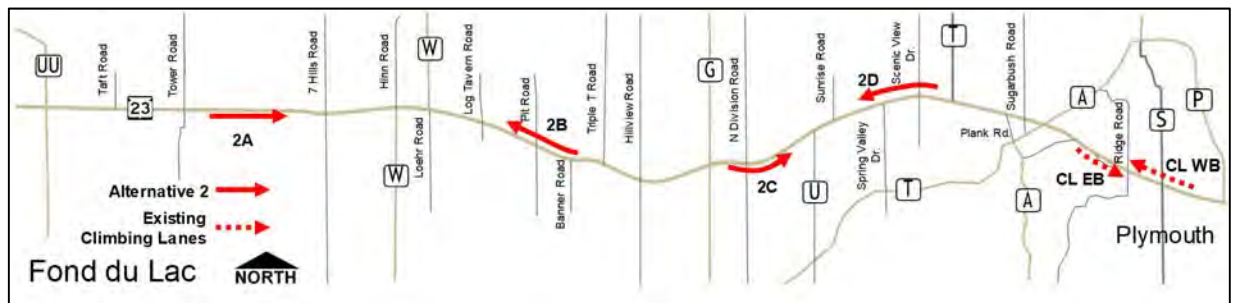

Figure 3: Proposed Passing Lane Locations and Existing Climbing Lane Locations

Section 2 of the 2018 LS SEIS provides more detail on the locations of the existing climbing lanes and the passing lanes proposed within the study limits. Page 15-32 of the HCM defines how to divide a roadway into four regions for a passing lane analysis. These four regions are defined as the following, along with the recommendations for inclusion from the HCM on Page 15-32:

- L_u = Length upstream of the passing lane (optional to include)
- L_{pl} = Length of the passing lane (required)
- L_{de} = Length downstream of the passing lane within its effective length (strongly recommended to include)
- L_d = Length downstream of the passing lane beyond its effective length (optional to include)

The analysis regions are required to add up to the total length of the analysis section. Per the HCM on Page 15-33:

The length of the conventional two-lane highway segment upstream of the passing lane L_u is determined by the actual or planned placement of the passing lane within the analysis segment. The length of the downstream highway segment within the effective

length of the passing lane L_{de} is determined from Exhibit 15-24. Any remaining length of the analysis segment downstream of the passing lane is included in L_d .

Page 15-34 of the HCM advises that the effective downstream distance of a passing lane should generally not be truncated. In cases where the effective downstream distance is truncated, the location at which the distance is truncated should occur where any of the following conditions are met as per Page 15-34 of the HCM:

- *The environment of the highway radically changes, as in the case of entering a small town or developed area from a rural segment;*
- *A major unsignalized intersection is present, leading to a change in the demand flow rate;*
- *A proximate signalized intersection begins to affect the operation of the two-lane segment;*
- *The terrain changes significantly; or*
- *Lane or shoulder widths change significantly.*

Page 15-10 of the HCM states that all segments with grades of 3 percent or more that cover a length of 0.6 miles or more must be analyzed as specific grades, rather than as a general terrain type such as “rolling”. For WIS 23, the climbing lane in the **westbound (WB)** direction of travel between Twinkle Lane and Ridge Road fits this definition with a length of 1.1 miles and an up-grade of approximately 4.6 percent for approximately 0.62 miles. In the **eastbound (EB)** direction of travel, the climbing lane between Plank Road and Ridge Road is approximately 0.5 miles in length with an up-grade of approximately 4 percent. For climbing lanes, the HCM recommends on Pages 15-36 and 15-37 that L_u , L_{de} , and L_d are each set to zero unless the climbing lane ends before the grade does.

Through discussion with WisDOT Bureau of Traffic Operations (BTO), the study team decided to analyze the EB climbing lane as a passing lane in order to be able to appropriately capture the two-lane highway segment downstream of the climbing lane between Ridge Road and County P. If the EB climbing lane is analyzed in isolation as a specific-grade, then a short section (approximately 1.3 miles) of WIS 23 EB between the climbing lane and County P would remain. If this short section of WIS 23 EB is analyzed separately as a two-lane highway analysis, it would not capture the operational effects of the upstream climbing lane. Additionally, the up-grade for the EB climbing lane (4 percent) is less than the WB side (4.6 percent), which was analyzed as a specific grade, and the EB climbing lane length (0.5 miles) is less than the length of 0.6 miles or more required by the HCM for specific-grade analysis.

The four regions (L_u , L_{pl} , L_{de} , and L_d) for each passing lane analysis were calculated following the guidelines indicated in the HCM. The following sections were analyzed in each Alternative:

1. No-Build **Alternative** - Eastbound
 - a. County UU to County G
 - b. County G to Climbing Lane
 - c. Climbing Lane (analyzed as a passing lane)

2. No-Build **Alternative** - Westbound
 - a. Climbing Lane (analyzed as a specific grade)
 - b. Climbing Lane to County G
 - c. County G to County UU
3. Passing Lane Alternative (see Alternative 2 labeling in Figure 5)
 - a. Eastbound: 2A, 2C, and existing climbing lane (as passing lane)
 - b. Westbound: 2B, 2D, and existing climbing lane (as specific grade)
4. Hybrid Alternative (See Alternative 2 labeling in Figure 6)
 - a. Eastbound: 2C, and existing climbing lane (as passing lane)
 - b. Westbound: 2D, and existing climbing lane (as specific grade)

Figure 4 shows the two-lane highway analysis sections along WIS 23 for the base conditions and 2040 No-Build Alternative.

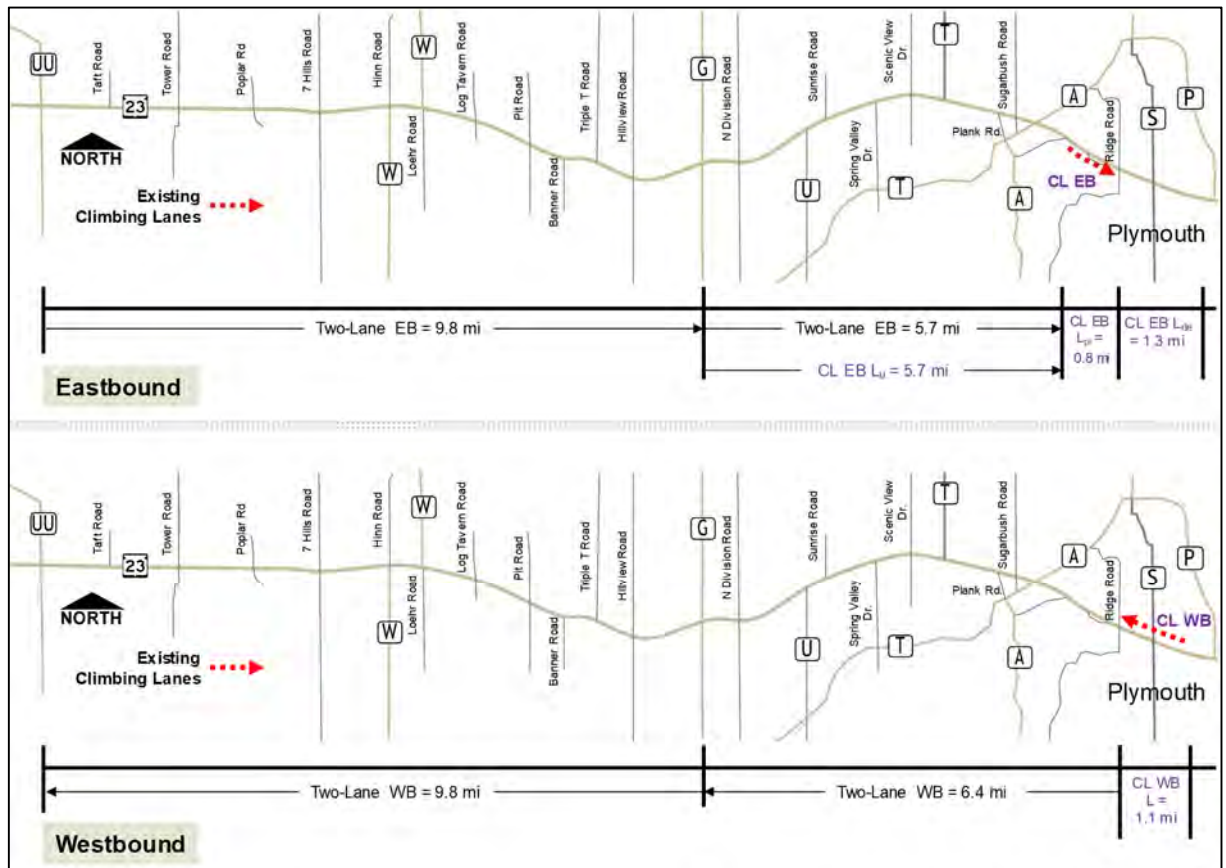

Figure 4: 2017 and 2040 No-Build **Alternative**: Two-Lane Highway Analysis Sections

Table 5 details the four regions for each passing lane analysis in the Passing Lane Alternative. Each of the lengths were originally calculated in feet and are rounded to the nearest tenth of a mile for presentation purposes in Table 5.

Analysis Section	Passing Lane Location (including tapers)	Upstream Length L_u (mi)	Passing Lane Length L_{pl} (mi)	Calculated Downstream Length (mi) ^[1]	Modeled Downstream Length L_{de} (mi)	Total Length $L_u + L_{pl} + L_{de}$ (mi)
2A (EB)	Sta 325+00 to 382+00	2.3 ^[2]	1.1	7.7	6.4 ^[3]	9.8
2B (WB)	Sta 550+50 to 618+00	1.9	1.3	7.7	6.6 ^[4]	9.8
2C (EB)	Sta 730+90 to 793+80	6.6	1.2	7.8	4.2 ^[5]	12.0
2D (WB)	Sta 848+65 to 907+65	2.9	1.1	7.8	4.3 ^[6]	8.3
CL EB	Plank to Ridge	4.2	0.8	7.4	1.3 ^[7]	6.3
CL WB	Twinkle to Ridge	0	0.62	0	0.48	1.1

- [1] Calculated downstream lengths are developed from Exhibit 12-23 of the HCM using Percent Time Spent Following (PTSF) as the performance measure. The directional demand value is based on the 2040 analysis direction volume (i.e. the peak direction) for the Passing Lane Alternative.
- [2] Upstream two-lane length is set to end at County UU due to change in volume and for consistency with the base conditions and No-Build analysis limits. The lane drop from two EB lanes to one EB lane is approximately 0.2 miles west of County UU.
- [3] Modeled length is less than calculated length because the next proposed passing lane is 6.6 miles downstream of the end of the taper for passing lane 2A. This qualifies as a significant change to mainline geometrics and therefore the downstream effective length was truncated to County G, which is a high volume unsignalized intersection approximately 6.4 miles downstream and consistent with the modeling limits of the No-Build analysis.
- [4] Modeled length is less than calculated length because the expansion to two lanes WB along WIS 23 is 7.1 miles downstream of the end of the taper for passing lane 2B. This qualifies as a significant change to mainline geometrics and therefore the downstream effective length was truncated to County UU, which is a high volume unsignalized intersection approximately 6.6 miles downstream and consistent with the modeling limits of the No-Build analysis.
- [5] Modeled length is less than calculated length because the climbing lane along WIS 23 EB is 4.2 miles downstream of the end of the taper for passing lane 2C. This qualifies as a significant change to mainline geometrics.
- [6] Modeled length is less than calculated length because the next proposed passing lane is 4.3 miles downstream of the end of the taper for passing lane 2D.
- [7] Modeled length is less than calculated length because the expansion to 2 lanes EB along WIS 23 is 1.3 miles downstream of the end of the climbing lane.

Table 5: WIS 23 Passing Lane Alternative: Region Lengths

It should be noted that there are overlapping analysis areas when defining the passing lane segments. This is necessary in order to reasonably replicate the downstream effective lengths recommended within HCM methodology. For example, in the Passing Lane Alternative the downstream effective length (L_{de}) for Analysis Section 2A overlaps with the upstream length (L_u) of Analysis Section 2C.

Figure 5 shows the two-lane highway analysis sections along WIS 23 for the 2040 Passing Lane Alternative.

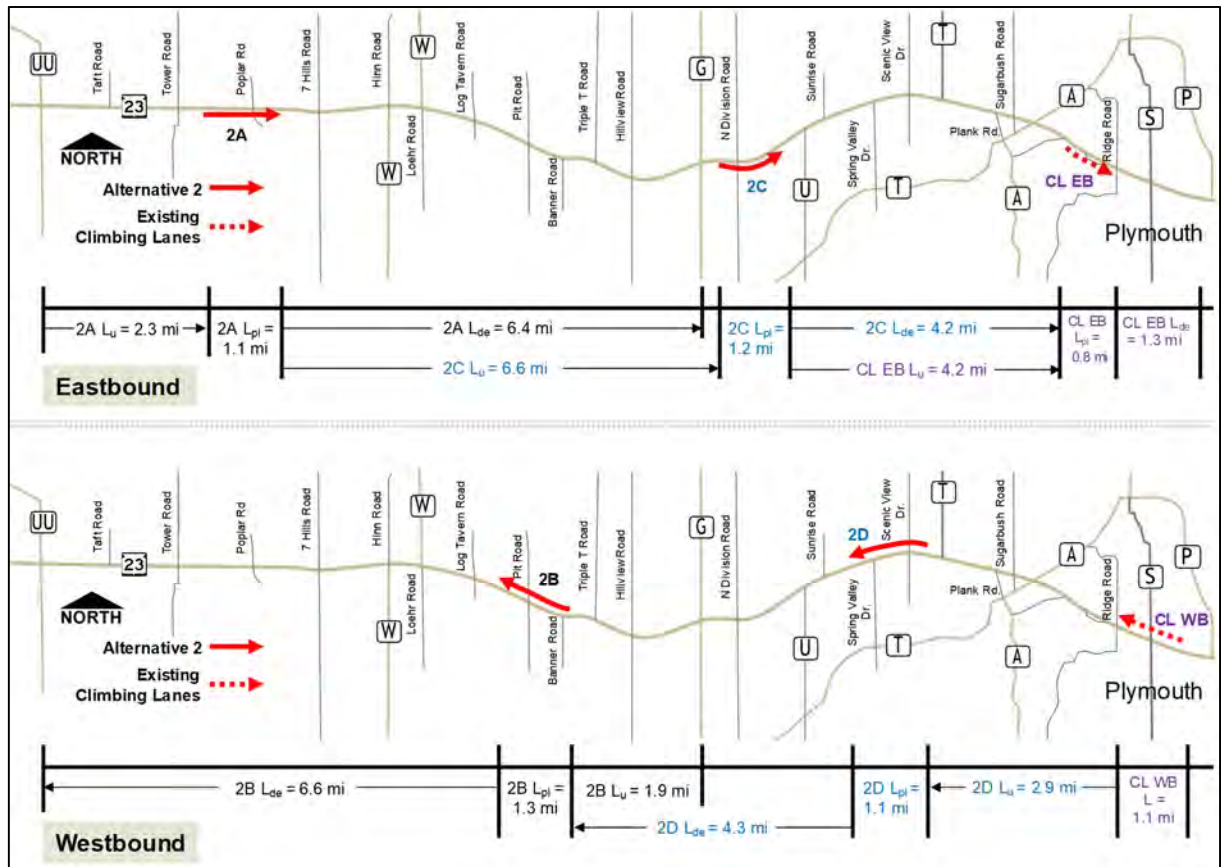

Figure 5: Passing Lane Alternative: Two-Lane Highway Analysis Sections

In the Hybrid Alternative, two different passing lane sections and the existing climbing lanes were analyzed. Table 6 details the four regions for each two-lane highway analysis performed in the Hybrid Alternative.

Analysis Section	Passing Lane Location (including tapers)	Upstream Length L_u (mi)	Passing Lane Length L_{pl} (mi)	Calculated Downstream Length (mi) ^[1]	Modeled Downstream Length L_{de} (mi)	Total Length $L_u + L_{pl} + L_{de}$ (mi)
2C (EB)	Sta 730+90 to 793+80	0.2 ^[2]	1.2	7.4	4.2 ^[3]	5.7
2D (WB)	Sta 848+65 to 907+65	2.9	1.1	7.4	2.5 ^[4]	6.5
CL EB	Plank to Ridge	4.2	0.8	7.0	1.3 ^[5]	6.3
CL WB	Twinkle to Ridge	0	0.62	0	0.48	1.1

[1] Calculated downstream lengths are developed from Exhibit 12-23 of the HCM using PTSF as the performance measure. The directional demand value is based on the 2040 analysis direction volume (i.e. the peak direction) for the Hybrid Alternative. The calculated downstream length for the hybrid alternative is less than those of the Passing Lane Alternative due to higher 2040 analysis direction volumes in the Hybrid Alternative analysis.

[2] Upstream two-lane length is set to end at County G interchange due to significant change in geometry.

[3] Modeled length is less than calculated length because the climbing lane along WIS 23 EB is 4.2 miles downstream of the end of the taper for passing lane 2C. This qualifies as a significant change to mainline geometrics.

[4] Modeled length is less than calculated length because the County G interchange (and 4-lane section west of County G) is 2.5 miles downstream, which constitutes as a significant change in mainline geometry.

[5] Modeled length is less than calculated length miles because the expansion to 2 lanes EB along WIS 23 is 1.3 miles downstream of the end of the climbing lane.

Table 6: WIS 23 Hybrid Alternative: Region Lengths

Figure 6 shows the two-lane highway analysis sections along WIS 23 for the 2040 Hybrid Alternative. The four-lane highway analysis is discussed in Section 4 of this memorandum.

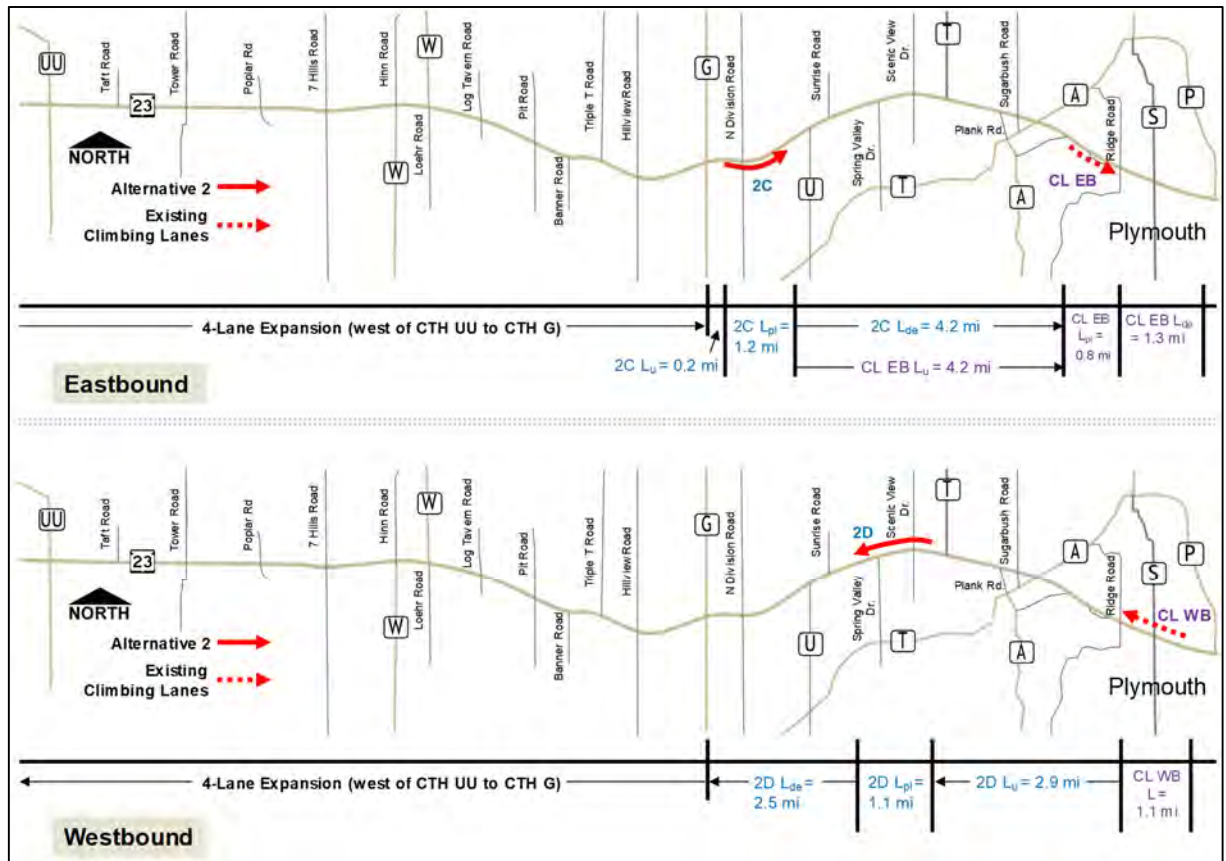

Figure 6: Hybrid Alternative: Two-Lane Analysis Sections

The region lengths discussed in this section include several L_{de} (downstream effective lengths) that are truncated due to significant changes in geometry along the mainline. Explanations for each truncated downstream effective length are in the footnotes of Tables 5 and 6. Because there are several L_{de} that needed to be truncated, the analysis team did not include L_d (downstream length of the passing lane beyond its L_{de}) in any of the region length calculations for consistency in the traffic analysis of each individual passing lane. The HCM indicates on Page 15-32, as stated previously, that L_d is an optional region and inclusion is at the discretion of the analyst.

It should be noted that the weighted average AADT volumes for the No-Build, Passing Lane Alternative and the Hybrid Alternative are based on the total lengths indicated in Figures 4-6 (and shown in Tables 5 and 6). Larger versions of Figures 4, 5, and 6 are included in Attachment B. The weighted average AADT volumes, two-way DHV volumes, analysis direction volumes, opposing direction volumes, and truck percentages for each of the two-lane highway analysis sections of each alternative are shown in Attachment C.

3. Highway Type

WIS 23 is classified as a Class I two-lane highway based on the HCM 6th edition definitions. Per page 15-4 of the HCM:

Class I two-lane highways are highways where motorists expect to travel at relatively high speeds. Two-lane highways that are major intercity routes, primary connectors of major traffic generators, daily commuter routes, or a major link in state or national highway networks are generally assigned to Class I. These facilities serve mostly long-distance trips or provide connections between facilities that serve long-distance trips.

WIS 23 fits the HCM definition of a Class I **two-lane** highway. The nearly 18-mile **two-lane portion of** WIS 23 is largely a rural corridor that connects two metropolitan urban areas, Fond du Lac and Sheboygan. The Fond du Lac core urban statistical area is home to about 101,600 people while the Sheboygan core urban statistical area is home to about 115,500 people³. I-41 is a major north-south corridor that connects the Fond du Lac area to Milwaukee and the Fox Valley and Green Bay. I-43 is a major north-south corridor that serves the Sheboygan area and connects it to Milwaukee and Green Bay. WIS 23 is one of the few higher mobility roadways that travel east-west through the region connecting these two interstate highways.

4. Terrain Type

The HCM allows classifications of level, rolling, or mountainous to be selected for terrain type in a two-lane highway analysis.

Per FDM 11-5-3.5.5 Rural Roadway Conditions on terrain type:

Wisconsin highways use only the level and rolling terrain classifications. Level terrain generally includes corridors that contain grades of no more than 3 percent. These corridors include any combination of horizontal and vertical alignment permitting heavy vehicles to maintain approximately the same speed as passenger cars.

Rolling terrain generally includes grades of significant length greater than 3 percent grade and will cause heavy vehicles to reduce their speed substantially below the speed of passenger cars. Typically, rolling terrain corridors are similar to those found near the Wisconsin River Valley, in the southwestern part of the State.

For WIS 23, level terrain is used for all two-lane highway and passing lane analyses except for the Eastbound Climbing Lane analysis in each alternative. For this analysis, rolling terrain is used because the grades along WIS 23 are over 3 percent within the segment limits. For the Westbound Climbing Lane, as mentioned previously, a specific-grade analysis is performed.

³ 2010 OMB Bulletin No 10-02

5. Access Point Density

Per page 15-16 of the HCM: The access point density is calculated by dividing the total number of unsignalized intersections and driveways on both sides of the roadway segment by the length of the segment (in miles). Table 7 shows a summary of the number of access points and the access point density for each analysis section.

Alternative and Analysis Section	# of Access Points	Access Points per Mile
No-Build: County UU to County G EB	134	14
No-Build: County G to Climbing Lane EB	62	11
No-Build: Climbing Lane EB Analysis - County G to West of County P	81	10
No-Build: Climbing Lane WB Analysis - Twinkle to Ridge	11	10
No-Build: Climbing Lane WB to County G	68	11
No-Build: County G to County UU WB	134	14
Passing Lane 2A: County UU to County G EB	134	14
Passing Lane 2B: County G to County UU WB	134	14
Passing Lane 2C: 2A to Climbing Lane EB	149	12
Passing Lane 2D: Climbing Lane WB to 2B	94	11
Hybrid 2C: County G to Climbing Lane EB	62	11
Hybrid 2D: Climbing Lane WB to County G	68	11
Passing Lane and Hybrid Alts: Climbing Lane EB Analysis - 2C to West of County P	61	10
Passing Lane and Hybrid Alts: Climbing Lane WB Analysis - Twinkle to Ridge	11	10

Table 7: Access Point Density Summary

Attachment D shows a more detailed corridor map used for the access point density calculations along with summary tables for each analysis section.

It should be noted that recent acquisitions since the 2014 LS SFEIS are not included in the access point density calculations used for the operations analysis. The recent acquisitions result in a net change of three fewer access points along the corridor based on a review performed by WisDOT Northeast region staff. The results of the two-lane highway operations analysis are not anticipated to substantially change based on testing performed with the No-Build Alternative.⁴

⁴ For the No-Build Alternative between County UU and County G, the net change in 3 less access points along the corridor results in one less access point per mile. There is no change in access points per mile between County G and County P. Testing performed in HCS with the 2040 No-Build Alternative between County UU and County G showed no change in numeric LOS along the corridor with the slightly lower access point density value.

6. No-Passing Zone Percentages

No-passing zone percentages were calculated for each analysis section using stationing from alignment files provided by WisDOT Northeast Region staff on September 28, 2017, Google Maps aeriels, and Google Street View. As of October 2017, when the no-passing zone percentages were calculated, Google Street View included November 2016 imagery along the WIS 23 corridor.

Two analyses are performed for the Passing Lane Alternative. The first includes no geometric improvements at intersections throughout the corridor. The second includes the addition of mainline left-turn bays at 9 intersections within the two-lane study limits, excluding County UU. The addition of mainline left-turn lanes increases the amount of no-passing zones within the corridor due to increased storage lengths and/or the addition of medians at the proposed intersection improvement locations. Calculations for the no-passing zone percentages for the No-Build Alternative, Passing Lane Alternative (without lefts), Passing Lane Alternative (with lefts), and the Hybrid Alternative (which includes the left-turn improvements at two-lane intersections in Sheboygan County) are shown in Attachment E. A summary of the no-passing zone percentages is shown in Table 8.

Alternative and Analysis Section	No-Passing Zone % (without lefts)	No-Passing Zone % (with lefts)
No-Build: County UU to County G EB	45%	<i>Not Analyzed</i>
No-Build: County G to Climbing Lane EB	32%	
No-Build: Climbing Lane EB Analysis: County G to West of County P	50%	
No-Build: Climbing Lane WB	92%	
No-Build: Climbing Lane WB to County G	35%	
No-Build: County G to County UU WB	47%	
Passing Lane 2A: County UU to County G EB	45%	59%
Passing Lane 2B: County G to County UU WB	47%	60%
Passing Lane 2C: 2A to Climbing Lane EB	44%	66%
Passing Lane 2D: Climbing Lane WB to 2B	40%	57%
Hybrid 2C: County G to Climbing Lane EB	<i>Not Analyzed</i>	63%
Hybrid 2D: Climbing Lane WB to County G		52%
Passing Lane and Hybrid Alts: Climbing Lane EB Analysis - 2C to West of County P	43% (Passing Lane)	71% (Passing Lane and Hybrid)
Passing Lane and Hybrid Alts: Climbing Lane WB Analysis - Twinkle to Ridge	92%	92%

Table 8: Mainline No-Passing Zone Percentage Summary

Section 4: Four-lane Highway and Interchange Merge/Diverge Analysis

The four-lane highway analysis for this study uses controlling (i.e. highest volume) 2040 peak hour volumes to determine the controlling basic, merge or diverge segment to analyze at proposed interchanges. In the **Hybrid and** 4-lane On-alignment Alternatives, interchanges are proposed at WIS 23/County UU and at WIS 23/County G. Attachment C shows a breakdown of the projected 2040 AM and PM peak hour traffic volumes for the WB merge, WB diverge, EB merge, EB diverge, and basic segments at each interchange location. The WB merge during the 2040 PM peak hour was determined to be the controlling interchange segment at each location. At the proposed WIS 23/County G interchange, the EB diverge was reviewed as well due to slightly higher ramp volumes.

For the Hybrid Alternative, a 4-lane roadway, anticipated to have a posted speed of 55 mph, would be provided between US 151 and County G. A free-flow speed of 60 mph was assumed for the 4-lane traffic operations analysis with the Hybrid Alternative to be consistent with the design speed of the facility, which is typically 5 mph over the posted speed limit.

The 4-lane On-alignment Alternative was designed to a 70 mph design speed (typically 5 mph above the posted speed). As a result of the design and expressway designation the facility will be posted at 65 mph, similar to portions of WIS 23 east of the study limits and other nearby 4-lane expressways such as US 151 between Columbus and Fond du Lac.⁵ Wis. Stat. § 345.57(4) defines Wisconsin's fixed speed limits related to expressway designation. A free-flow speed of 70 mph was assumed for the 4-lane traffic operations analysis with the 4-lane On-alignment Alternative to be consistent with the design speed of the facility.

To determine the mainline volume upstream of the WB merge, the K30 Analysis Direction Volume was found from Site 201147 for the County UU interchange and from Site 590118 for the County G interchange. A similar process was used for the EB diverge analysis at County G. The basic sections of WIS 23 east and west of each interchange were also reviewed for the 4-lane highway analysis. The mainline volumes for the HCS analysis are also shown in Attachment C, along with the corresponding ramp volume and upstream or downstream ramp volume for each interchange location. The results for the interchange analysis are intended to show the "worst-case" 4-lane segment within the study corridor.

⁵ The urbanized segment on the west end of the corridor will be posted at 45 mph, the same as existing. Any other areas of posted speed limits below 65 mph will be determined during final design.

Section 5: Intersection Analysis

The intersections being analyzed in this study are County UU, County W/Loehr Road, and County G.

Inputs into the intersection analysis include:

1. Volumes: From WisDOT AM and PM peak hour traffic forecasts prepared April 6, 2018.
2. Peak Hour Factor: Overall intersection value from traffic counts performed in summer 2017 per FDM 11-5-3.5.3.2.2.
3. Truck Percentage: Intersection approach value from traffic counts performed in summer 2017. For the Restricted Crossing U-Turn (RCUT), or J-Turn, analysis, the truck percentages for individual movements were used in order to accurately represent the U-turn movements with this intersection treatment.
4. Headway Factors: Default headway settings were used for the two-way stop control analysis. For the U-turn movements at the proposed J-Turns, critical headway and follow-up headway values were calculated based on guidance from Page 23-77 of the HCM. These calculations are included in Attachment F.
5. Median Storage (No-Build): Per site conditions.
6. Median Storage (Passing Lane with lefts, Hybrid, 4-lane On-alignment): One vehicle.

WisDOT forecasts were provided for the No-Build Alternative and the 4-lane On-alignment Alternative at each location analyzed. For the Passing Lane Alternative, the mainline forecasts are slightly higher than the No-Build Alternative forecasts within the two-lane portion of the corridor. In order to analyze the same intersections with the Passing Lane Alternative, the study team factored the 2040 No-Build Alternative intersection forecasts up (all movements) based on the relationship between the Passing Lane Alternative mainline forecast and No-Build Alternative mainline forecast on both sides of the study intersection. Similarly, for the Hybrid Alternative, the 2040 4-lane On-alignment Alternative forecasts were factored down (all movements) based on the relationship between the Hybrid Alternative and the 4-lane On-alignment Alternative mainline forecasts. These example calculations are shown in Attachment F.

At the proposed interchanges in the Hybrid Alternative and 4-lane On-alignment Alternative, single-lane roundabouts may be incorporated at the ramp terminal intersections. Roundabouts are shown at the interchanges because they have a larger footprint, representing the greatest impacts. Determination of intersection type will be done during final design.

The alternative intersection methodology (HCM Chapter 23) will be used to supplement the control-delay based operations analysis of the proposed RCUT at the County W/Loehr Road intersection in the Hybrid Alternative and 4-lane On-alignment Alternative.

Section 6: Summary

1. WisDOT Review

The study team received approval from the WisDOT BTO on the proposed software (HCS) and modeling methodology for the WIS 23 traffic analysis on October 5, 2017. A peer review of the HCS files were performed by WisDOT BTO in April 2018 based on the April 6, 2018 traffic forecasts. The two-lane mainline analysis and results were approved on April 9, 2018. The four-lane mainline and intersection analyses were approved on April 12, 2018. The peer review documentation is located in Attachment G.

2. Operations Results

Summary tables detailing results of the mainline and intersection operations results are included in Attachment H. The mainline operations analysis contains two sets of results based on varying Peak Hour Factor (PHF) inputs, as described in the “DHV for WIS 23 Evaluation” memo located in Appendix A of the 2018 LS SEIS. The fully uniform analysis (PHF of 1.0) follows WisDOT policy and is used to report operations in the body of the 2018 LS SEIS. The existing peak hour pattern (PHF of 0.89) is a sensitivity analysis used to evaluate 2040 conditions along WIS 23 if peaking patterns remain the same as 2017 conditions.

Analysis of probe data (Global Positioning System [GPS] data from phones or vehicles) for the WIS 23 corridor indicates that travel speeds on WIS 23 vary from those predicted by HCS. The probe data speeds, from the National Performance Management Research Data Set (NPMRDS), were downloaded from June 2017 to coincide with the dates the mainline traffic counts were taken along the two-lane sections of WIS 23. Average speeds from the NPMRDS probe data were found to be approximately 58 miles per hour along WIS 23. Average travel speeds predicted with HCS are around 48 miles per hour for 2017 conditions.

The NPMRDS travel speed data is considered more reliable than HCS by WisDOT for use in evaluating speeds and travel times along WIS 23 because the probe data reflects observed, and not predicted, travel speeds. For the 2040 alternatives analysis, the relative difference in speeds predicted by HCS was used in combination with the 2017 probe data to estimate 2040 speeds and travel times along the corridor. Attachment H shows example calculations of estimated speeds and travel times for the existing conditions and alternatives analysis.

ATTACHMENT A
SCHEMATIC MAPS OF MAINLINE ALTERNATIVES

WIS 23 (US 151 – County P) Alternatives

Passing Lane Alternative

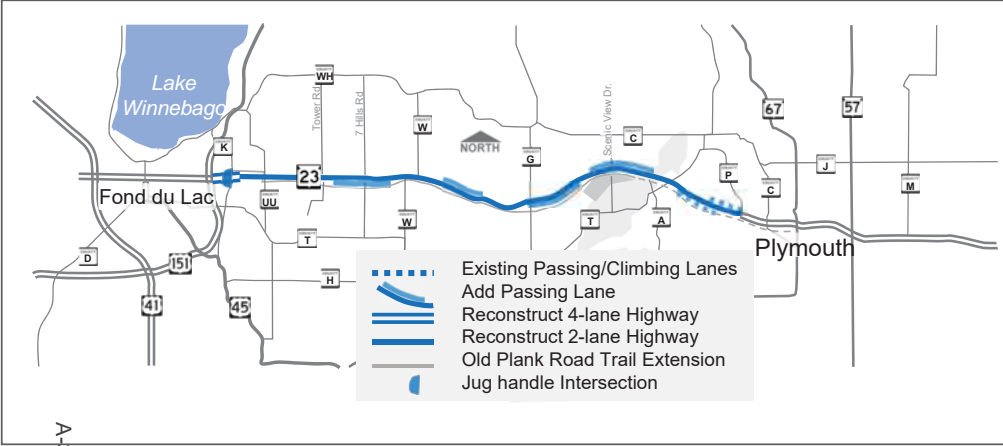

Hybrid Alternative

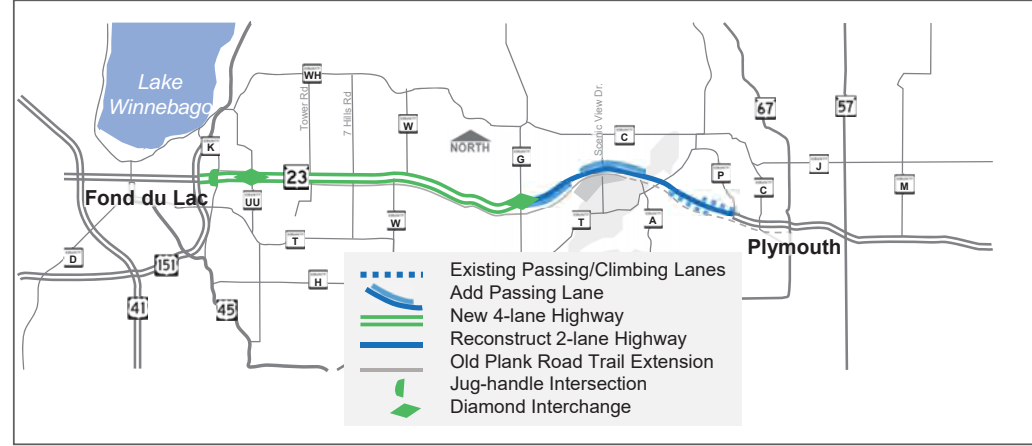

4-lane On-alignment Alternative

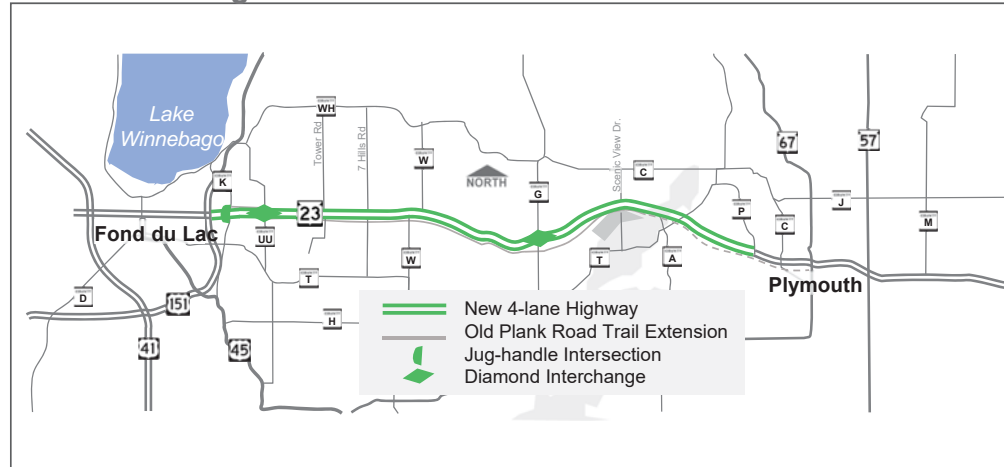

ATTACHMENT B
NO-BUILD AND ALTERNATIVE SEGMENT LENGTH MAPS

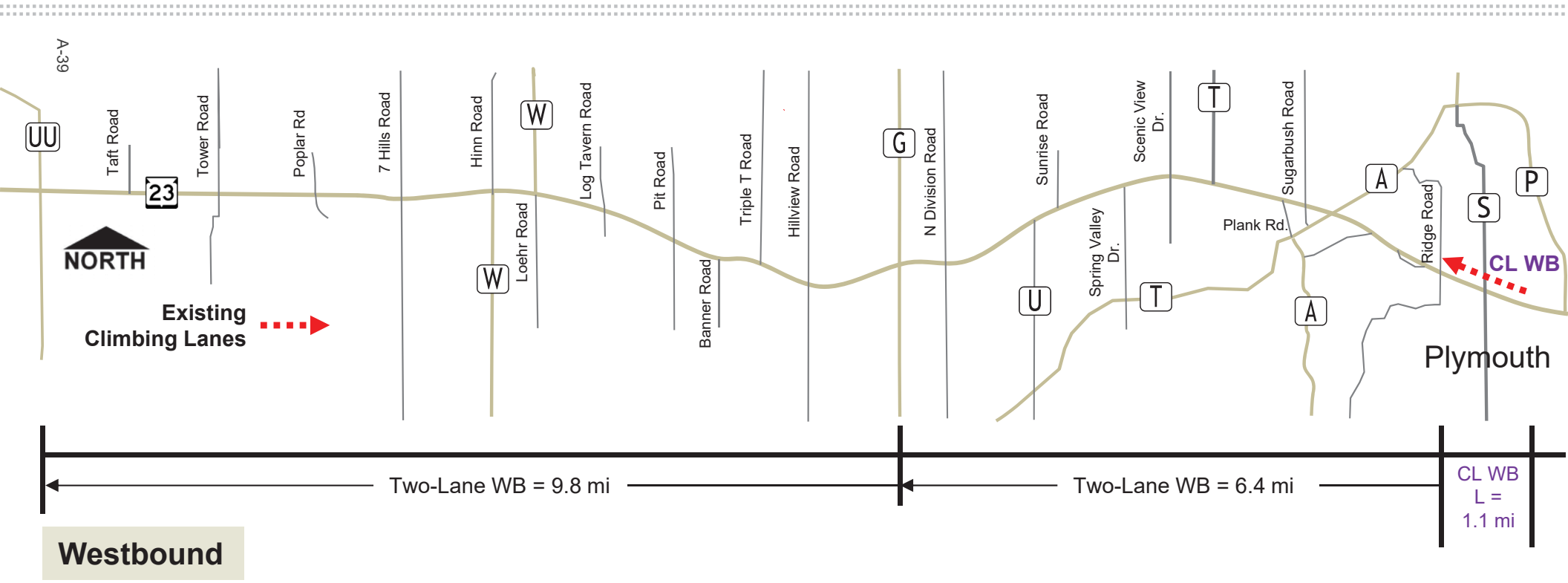
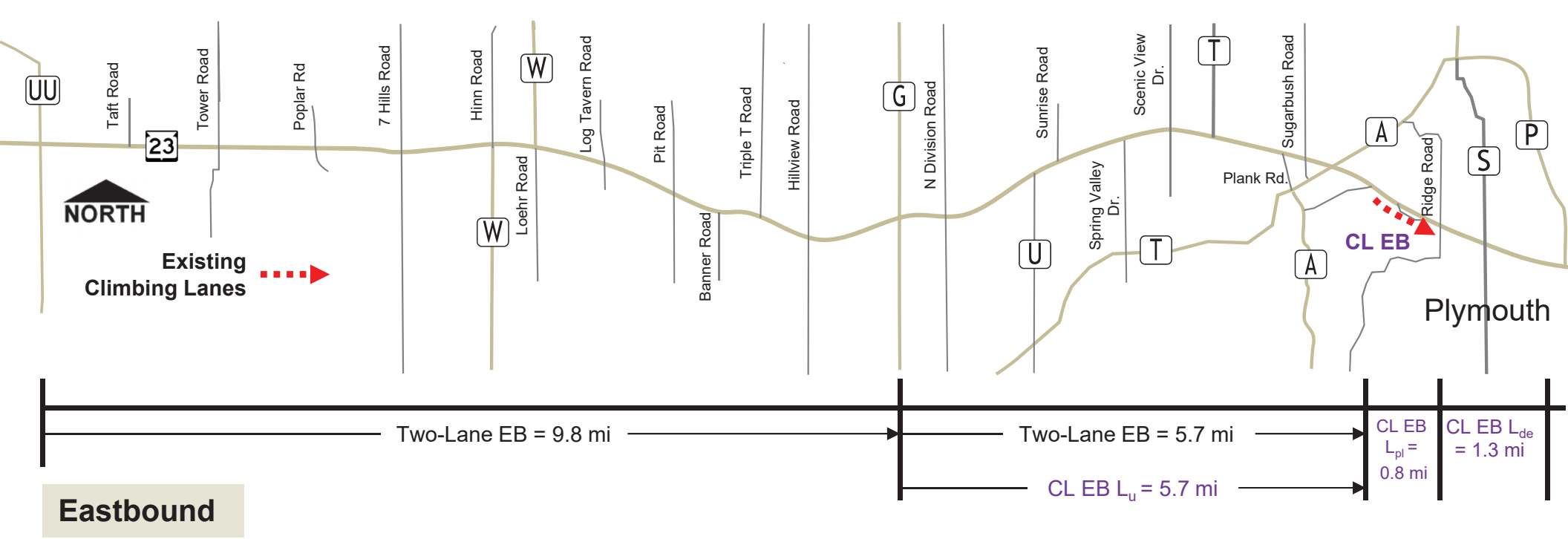

NO-BUILD

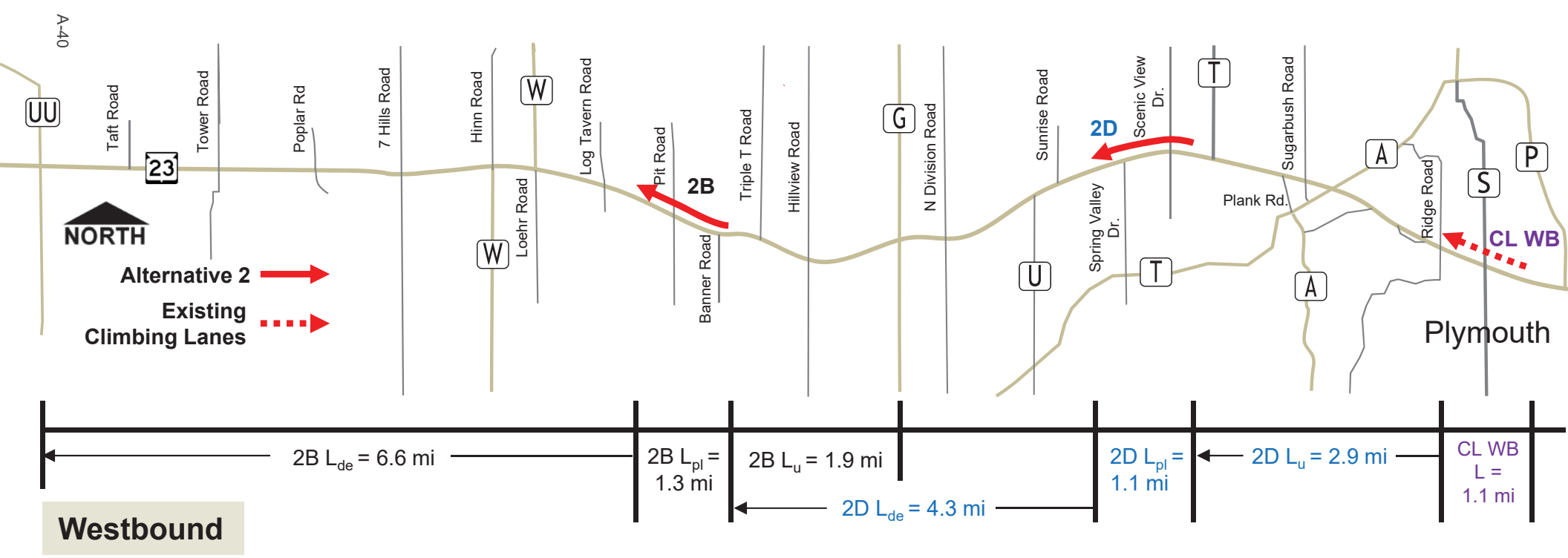
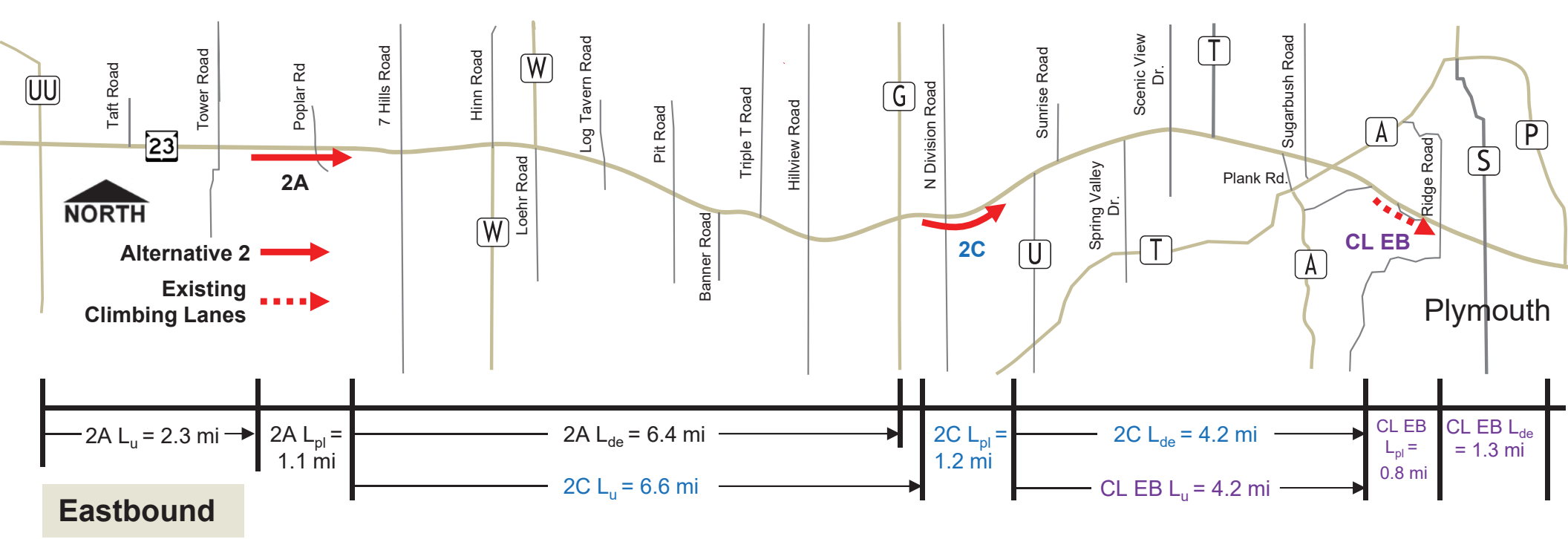

PASSING LANE ALTERNATIVE



4-Lane Expansion (west of CTH UU to CTH G)

$2C L_u = 0.2 \text{ mi}$
 $2C L_{pl} = 1.2 \text{ mi}$
 $2C L_{de} = 4.2 \text{ mi}$
 $CL EB L_u = 4.2 \text{ mi}$
 $CL EB L_{pl} = 0.8 \text{ mi}$
 $CL EB L_{de} = 1.3 \text{ mi}$

Eastbound



4-Lane Expansion (west of CTH UU to CTH G)

$2D L_{de} = 2.5 \text{ mi}$
 $2D L_{pl} = 1.1 \text{ mi}$
 $2D L_u = 2.9 \text{ mi}$
 $CL WB L = 1.1 \text{ mi}$

Westbound

HYBRID ALTERNATIVE

ATTACHMENT C
WIS 23 MAINLINE TRAFFIC ANALYSIS INPUT WORKSHEETS

Projected Traffic Volumes: No Build Alternative

4/9/2018

FOND DU LAC COUNTY

CTH UU to CTH G

Road Segment	Site ID	Distance (ft)	Distance (mi)	Forecast Data			
				2017	2020	2030	2040
CTH UU to Tower	201147	10,490	2.0	7,400	7,500	7,900	8,300
Tower to Hinn/W	206104	15,980	3.0	7,300	7,400	7,600	7,900
Hinn/W to Loehr/W	200222	2,610	0.5	7,400	7,500	7,600	7,800
Loehr/W to Hillview	200224	17,000	3.2	6,900	7,000	7,000	7,100
Hillview to CTH G	201153	5,420	1.0	6,800	6,800	6,800	6,900

Total Dist (ft)	Total Dist (mi)
51,500	9.8 CTH UU to CTH G

Truck % = 17
Terrain = Level (<3%)

	2017	2020	2030	2040
CTH UU to CTH G (used 2017 base conditions and no-build)				
Weighted AADT	7,140	7,230	7,380	7,610
K30	0.10	714	723	738
Peak Dir	0.58	414	419	428
Opp Dir	0.42	300	304	310

SHEBOYGAN COUNTY

CTH G to CTH P

Road Segment	Site ID	Distance (ft)	Distance (mi)	Forecast Data			
				2017	2020	2030	2040
CTH G to CTH T (N)	590118	19,600	3.7	6,700	6,700	6,700	6,800
CTH T (N) to CTH A	591421	7,450	1.4	7,800	7,800	7,800	7,900
CTH A to CTH S	591422	9,730	1.8	8,400	8,500	8,600	8,700
CTH S to CTH P	590195	5,520	1.0	9,400	9,500	9,600	9,700

Total Dist (ft)	Total Dist (mi)
30,010	5.7 CTH G to Climbing Lane

Total Dist (ft)	Total Dist (mi)
40,830	7.7 CTH G to just west of CTH P

Total Dist (ft)	Total Dist (mi)
5,700	1.1 Climbing Lane only

Total Dist (ft)	Total Dist (mi)
34,050	6.4 Climbing Lane to CTH G

Truck % = 13
Terrain = Rolling (>3% in areas)

	2017	2020	2030	2040
EB: CTH G to Climbing Lane				
Weighted AADT	7,140	7,150	7,160	7,260
K30	0.10	714	715	716
Peak Dir	0.58	414	415	415
Opp Dir	0.42	300	300	301

	2017	2020	2030	2040
EB: CTH G to west of CTH P (Climbing Lane analysis)				
Weighted AADT	7,570	7,610	7,640	7,740
K30	0.10	757	761	764
Peak Dir	0.58	439	441	443
Opp Dir	0.42	318	320	321

	2017	2020	2030	2040
WB: Climbing Lane only				
Weighted AADT	8,910	9,010	9,110	9,210
K30	0.10	891	901	911
Peak Dir	0.58	517	523	528
Opp Dir	0.42	374	378	383

	2017	2020	2030	2040
WB: Climbing Lane to CTH G				
Weighted AADT	7,290	7,310	7,330	7,430
K30	0.10	729	731	733
Peak Dir	0.58	423	424	425
Opp Dir	0.42	306	307	308

Note: All AADT volumes reported are from WisDOT forecast completed 4-6-2018, Appendix A (NERTDM only)

Assumptions

K30 from ATR 590608
DD from ATR 590608
Truck % from field data (PM peak)
See DHV for WIS 23 Evaluation memo and Traffic Modeling Methodology memo for more background.

Passing Lane Length, Volume, and Truck Percentage Summary: Passing Lane Alternative and Hybrid Alternative
4/9/2018

FOND DU LAC COUNTY

CTH UU to CTH G - Passing Lane Alternative		Forecast Data					
Road Segment	Site ID	Distance (ft)	Distance (mi)	2017	2020	2030	2040
CTH UU to Tower	201147	10,480	2.0	7,400	7,500	8,000	8,500
Tower to HinnaW	206104	15,980	3.0	7,300	7,400	7,800	8,100
HinnaW to LoehrW	200222	2,610	0.5	7,400	7,500	7,700	8,000
LoehrW to Hillview	200224	17,000	3.2	6,900	7,000	7,100	7,300
Hillview to CTH G	201153	5,420	1.0	6,800	6,800	7,000	7,100

SHEBOYGAN COUNTY

CTH G to CTH P - Passing Lane Alternative		Forecast Data					
Road Segment	Site ID	Distance (ft)	Distance (mi)	2017	2020	2030	2040
CTH G to CTH T (N)	590118	19,600	3.7	6,700	6,700	6,900	7,000
CTH T (N) to CTH A	591421	7,450	1.4	7,800	7,800	8,000	8,100
CTH A to CTH S	591422	9,730	1.8	8,400	8,500	8,700	8,800
CTH S to CTH P	590195	5,520	1.0	9,400	9,500	9,700	9,900

SHEBOYGAN COUNTY

CTH G to CTH P - Hybrid Alternative		Forecast Data					
Road Segment	Site ID	Distance (ft)	Distance (mi)	2017	2020	2030	2040
CTH G to CTH T (N)	590118	19,600	3.7	6,700	6,800	7,400	7,900
CTH T (N) to CTH A	591421	7,450	1.4	7,800	7,900	8,500	9,000
CTH A to CTH S	591422	9,730	1.8	8,400	8,800	9,100	9,600
CTH S to CTH P	590195	5,520	1.0	9,400	9,600	10,100	10,600

TRUCK PERCENTAGES

Fond du Lac County	17.0%	from field data
Sheboyan County	13.0%	from field data

Weighted Average Truck Percentages for Passing Lane Analysis

Scenario	FDL dist (mi)	Sheb dist (mi)	Truck %	HCM Exhibit 15-23 Downstream Length		
				Directional Demand	PTSF (mi)	ATS (mi)
2A - Passing Lane Alt	9.8	0.0	17.0%	<200	13.0	1.7
2B - Passing Lane Alt	9.8	0.0	17.0%	300	11.6	1.7
2C - Passing Lane Alt	6.4	5.7	15.1%	400	8.1	1.7
2D - Passing Lane Alt	1.9	6.4	13.9%	500	7.3	1.7
CL EB - Passing Lane Alt	0.0	6.3	13.0%	600	6.5	1.7
CL WB - Passing Lane Alt	0.0	1.1	13.0%	700	6.7	1.7
2D - Hybrid Alt	0.0	6.5	13.0%	800	5.0	1.7
CL EB - Hybrid Alt	0.0	6.3	13.0%	900	4.3	1.7
CL WB - Hybrid Alt	0.0	1.1	13.0%	>1,000	3.6	1.7

Divider for FDL vs. Sheb measured from CTH G, just west of actual county line.

2A - Passing Lane Alternative

Category	Length	Limits	Total
Upstream	2.3	E of Tower to CTH UU	
Passing Lane	4300	Sta 332+00 to 375+00	
Passing Lane Tapers	700	700' on each end	
Passing Lane Length + Tapers	1.1		
Downstream Eff. Length	6.4	to CTH G	
Downstream Eff. Length (HCM)	7.7	based on 453 vph	

2C - Passing Lane Alternative

Category	Length	Limits	Total
Upstream	6.6	to end of 2A (East of Poplar)	
Passing Lane	4890	Sta 737+90 to 786+80	
Passing Lane Tapers	700	700' on each end	
Passing Lane Length + Tapers	1.2		
Downstream Eff. Length (L ₉₀)	4.2	end of PL to Climbing Lane	
Downstream Eff. Length (HCM)	7.8	based on 434 vph	

2C - Hybrid Alternative

Category	Length	Limits	Total
Upstream	0.2	to CTH G (4-lane)	
Passing Lane	4890	Sta 737+90 to 786+80	
Passing Lane Tapers	700	700' on each end	
Passing Lane Length + Tapers	1.2		
Downstream Eff. Length (L ₉₀)	4.2	end of PL to Climbing Lane	
Downstream Eff. Length (HCM)	7.4	based on 484 vph	

CL EB - Passing Lane Alternative

Category	Length	Limits	Total
Upstream	4.2	end of PL to Climbing Lane	
Passing Lane	3890		
Passing Lane Tapers (1)	140	Only on west end	
Passing Lane Length + Tapers	0.8		
Downstream Eff. Length	1.3		
Downstream Eff. Length (HCM)	7.4	based on 483 vph	

CL EB - Hybrid Alternative

Category	Length	Limits	Total
Upstream	4.2		
Passing Lane	3890		
Passing Lane Tapers	140	Only on west end	
Passing Lane Length + Tapers	0.8		
Downstream Eff. Length	1.3		
Downstream Eff. Length (HCM)	7.0	based on 532 vph	

CL WB - Passing Lane and Hybrid Alternative

Category	Length	Limits	Total
Upstream	0.0	HCM recommended = 0	
Passing Lane	5700		
Passing Lane Length + Tapers	1.1		
Downstream Eff. Length	0	HCM recommended = 0	
Downstream Eff. Length (HCM)	0	HCM recommended = 0	

2D - Passing Lane Alternative

Category	Length	Limits	Total
Upstream	2.9	Sta 907+65 to end of Climbing Lane	
Passing Lane	4500	Sta 855+65 to 900+65	
Passing Lane Tapers	700	700' on each end	
Passing Lane Length + Tapers	1.1		
Downstream Eff. Length (L ₉₀)	4.3	to start of 2B (East of Banner Rd)	
Downstream Eff. Length (HCM)	7.8	based on 436 vph	

2D - Hybrid Alternative

Category	Length	Limits	Total
Upstream	2.9	Sta 907+65 to end of Climbing Lane	
Passing Lane	4500	Sta 855+65 to 900+65	
Passing Lane Tapers	700	700' on each end	
Passing Lane Length + Tapers	1.1		
Downstream Eff. Length	2.5	to CTH G (4-lane)	
Downstream Eff. Length (HCM)	7.4	based on 492 vph	

2B - Passing Lane Alternative

Category	Length	Limits	Total
Upstream	1.9	E of Pit to CTH G	
Passing Lane	5350	Sta 557+50 to 611+00	
Passing Lane Tapers	700	700' on each end	
Passing Lane Length + Tapers	1.3		
Downstream Eff. Length	6.6	to CTH UU	
Downstream Eff. Length (HCM)	7.7	based on 453 vph	

TOTAL SEGMENT LENGTHS

2A - Passing Lane Alternative	
Total Dist (ft)	51,500
Total Dist (mi)	9.8 CTH UU to CTH G

2C - Passing Lane Alternative	
Total Dist (ft)	63,600
Total Dist (mi)	12.0 East of Poplar (End of 2A) to Start of CL EB

2C - Hybrid Alternative	
Total Dist (ft)	30,010
Total Dist (mi)	6.7 CTH G to Start of CL EB

CL EB - Passing Lane Alternative and Hybrid Alternative	
Total Dist (ft)	33,350
Total Dist (mi)	6.3

CL WB - Passing Lane Alternative and Hybrid Alternative	
Total Dist (ft)	6,700
Total Dist (mi)	1.1 Climbing Lane: Twinkle to Ridge

2D - Passing Lane Alternative	
Total Dist (ft)	43,920
Total Dist (mi)	8.3 End of Climbing Lane (Ridge Rd) to East of Banner Rd

2D - Hybrid Alternative	
Total Dist (ft)	34,350
Total Dist (mi)	6.5 End of Climbing Lane (Ridge Rd) to CTH G

2B - Passing Lane Alternative	
Total Dist (ft)	51,500
Total Dist (mi)	9.8 CTH G to CTH UU

WEIGHTED AVERAGE VOLUMES (EASTBOUND)

	2017	2020	2030	2040	
Weighted ADT	7,140	7,230	7,520	7,810	
K30	0.10	714	723	752	781
Peak Dir	0.58	414	419	436	453
Opp Dir	0.42	300	304	316	328

	2017	2020	2030	2040	
Weighted ADT	7,080	7,130	7,330	7,490	
K30	0.10	708	713	733	749
Peak Dir	0.58	411	414	425	434
Opp Dir	0.42	297	299	308	315

	2017	2020	2030	2040	
Weighted ADT	7,140	7,250	7,840	8,340	
K30	0.10	714	725	784	834
Peak Dir	0.58	414	421	455	484
Opp Dir	0.42	300	304	329	350

	2017	2020	2030	2040	
Weighted ADT	7,970	8,020	8,220	8,330	
K30	0.10	797	802	822	833
Peak Dir	0.58	462	465	477	483
Opp Dir	0.42	335	337	345	350

	2017	2020	2030	2040	
Weighted ADT	7,370	8,120	8,670	9,170	
K30	0.10	737	812	867	917
Peak Dir	0.58	462	471	503	532
Opp Dir	0.42	335	341	364	385

WEIGHTED AVERAGE VOLUMES (WESTBOUND)

	2017	2020	2030	2040	
Weighted ADT	8,910	9,010	9,210	9,360	
K30	0.10	891	901	921	936
Peak Dir	0.58	517	523	534	543
Opp Dir	0.42	374	378	387	393

	2017	2020	2030	2040	
Weighted ADT	8,910	9,110	9,610	10,110	
K30	0.10	891	911	961	1,011
Peak Dir	0.58	517	528	557	586
Opp Dir	0.42	374	383	404	425

	2017	2020	2030	2040	
Weighted ADT	7,190	7,220	7,410	7,520	
K30	0.10	719	722	741	752
Peak Dir	0.58	417	419	430	436
Opp Dir	0.42	302	303	311	316

	2017	2020	2030	2040	
Weighted ADT	7,290	7,410	7,990	8,490	
K30	0.10	729	741	799	849
Peak Dir	0.58	423	430	463	492
Opp Dir	0.42	306	311	336	357

	2017	2020	2030	2040	
Weighted ADT	7,140	7,230	7,520	7,810	
K30	0.10	714	723	752	781
Peak Dir	0.58	414	419	436	453
Opp Dir	0.42	300	304	316	328

Note: All AADT volumes reported are from WisDOT forecast completed 4-6-2018, Appendix A (NERTDM only)

Assumptions

K30 from ATR 590608
DD from ATR 590608
Truck % from field data (PM peak)
See DHV for WIS 23 Evaluation memo and Traffic Modeling Methodology memo for more background.

Projected Traffic Volumes: 4-Lane On-Alignment Alternative (4 lanes CTH G to CTH P)

4/9/2018

FOND DU LAC COUNTY

CTH UU to CTH G

Road Segment	Site ID	Distance (ft)	Distance (mi)	Forecast Data			
				2017	2020	2030	2040
CTH UU to Tower	201147	10,490	2.0	7,400	8,000	10,000	11,900
Tower to Hinn/W	206104	15,980	3.0	7,300	7,900	9,800	11,700
Hinn/W to Loehr/W	200222	2,610	0.5	7,400	7,900	9,600	11,200
Loehr/W to Hillview	200224	17,000	3.2	6,900	7,300	8,700	10,100
Hillview to CTH G	201153	5,420	1.0	6,800	7,200	8,500	9,900

	2017	2020	2030	2040
CTH UU to CTH G - not used in 4-lane operations analysis				
Weighted AADT	7,140	7,650	9,330	11,000
K30	0.10	714	765	933
Peak Dir	0.58	414	444	541
Opp Dir	0.42	300	321	392

Total Dist (ft)	Total Dist (mi)
51,500	9.8 CTH UU to CTH G

Truck % = 17
Terrain = Level (<3%)

Mainline E of CTH UU (Site ID 201147: K30, peak dir)
Mainline W of CTH UU (Site ID 200219: K30, peak dir)
2040 Hybrid W of CTH UU (Site ID 200219: K30, peak dir)

CTH UU forecast (2040 volumes)

	AM	PM
WB merge	33	39
WB diverge	8	32
EB merge	20	31
EB diverge	17	31
	690	
	969	
	905	

WB Merge Analysis (2040 PM ramp vols)	
Mainline Vol	658
Ramp Vol	39

EB Diverge Analysis (2040 PM ramp vols)	
Mainline Vol	969
Ramp Vol	31

SHEBOYGAN COUNTY

CTH G to CTH P

Road Segment	Site ID	Distance (ft)	Distance (mi)	Forecast Data			
				2017	2020	2030	2040
CTH G to CTH T (N)	590118	19,600	3.7	6,700	7,100	8,300	9,500
CTH T (N) to CTH A	591421	7,450	1.4	7,800	8,200	9,500	10,900
CTH A to CTH S	591422	9,730	1.8	8,400	8,800	10,000	11,200
CTH S to CTH P	590195	5,520	1.0	9,400	9,800	11,100	12,300

	2017	2020	2030	2040
CTH G to CTH P - not used in 4-lane operations analysis				
Weighted AADT	7,640	8,040	9,270	10,500
K30	0.10	764	804	927
Peak Dir	0.58	443	466	538
Opp Dir	0.42	321	338	441

Total Dist (ft)	Total Dist (mi)
42,300	8.0 CTH G to CTH P

Truck % = 13
Terrain = Rolling (>3% in areas)

Mainline E of CTH G (Site ID 590118: K30, peak dir)
Mainline W of CTH G (Site ID 201153: K30, peak dir)

	AM	PM
WB merge	52	60
WB diverge	14	32
EB merge	17	27
EB diverge	51	71
	551	
	574	

WB Merge Analysis (2040 PM ramp vols)	
Mainline Vol	519
Ramp Vol	60

EB Diverge Analysis (2040 PM ramp vols)	
Mainline Vol	574
Ramp Vol	71

Note: All AADT volumes reported are from WisDOT forecast completed 4-6-2018, Appendix A (NERTDM only)

Assumptions

K30 from ATR 590608

DD from ATR 590608

Truck % from field data (PM peak)

See DHV for WIS 23 Evaluation memo and Traffic Modeling Methodology memo for more background.

A-45

WisDOT TRAFFIC FORECAST REPORT

Region/COUNTY(IES): NE / Fond du Lac & Sheboygan

Developed by: Chris Chritton

PROJECT ID(S): 1440-13-00 & 1440-15-00

LOCATION: USH 151 - CTH P

Phone: (608) 266-0194

ROUTE(S): STH 23 (No-Build Alternative - NERTDM Only)

COMPLETED: April 6, 2018

FAX: (608) 267-0294

E-Mail: chris.chritton@dot.wi.gov



Traffic Forecasting Section; Bureau of Planning and Economic Development; Division of Transportation Investment Management

Site(s)	Route(s)	Volume(s)	Site Growth %	Design Values (%)							Truck Classification						Total %
				K250	K100	K30	P	D(Dsgn. Hr.)	T(DHV)	T(PHV)	AADTT	2D	3AX	2S1+2S2	3-S2	DBL-BTM	
201147	STH 23	8300	0.53%	9.3	10.0	10.7	12.4	60/40	19.1	10.2	1680	9.6	2.6	2.1	8.1	0.2	22.7%
206104		7890	0.34%	9.3	10.0	10.7	12.4	60/40	21.6	11.6	1880	12.1	3.3	2.1	8.0	0.2	25.7%
200222		7810	0.23%	9.3	10.0	10.7	12.5	60/40	19.6	10.5	1730	9.8	2.7	2.2	8.4	0.2	23.3%

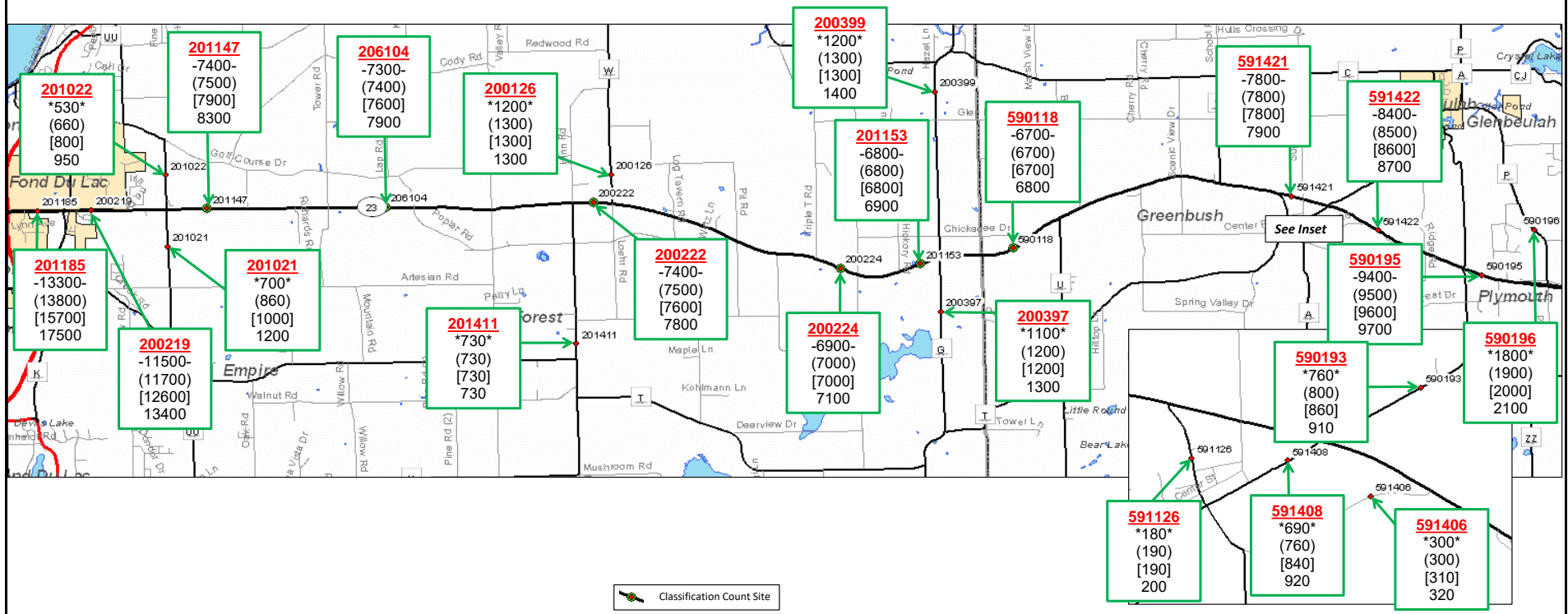

A-46

Full Vehicle Classification																
Site(s)	Route(s)	MC	CARS	SU2-4	BUSES	SU2-6	SU3	SU4+	ST4-	ST5	ST6+	MU5-	MU6	MU7+	TRUCKS	TOTAL
201147	STH 23	0.5	58.6	18.2	2.1	7.6	1.8	0.8	2.1	7.6	0.5	0.1	0.0	0.0	22.7	100.0
206104		0.5	56.4	17.5	2.6	9.5	2.3	1.0	2.1	7.5	0.5	0.1	0.0	0.0	25.7	100.0
200222		0.5	58.2	18.1	2.1	7.7	1.9	0.8	2.2	7.9	0.5	0.1	0.0	0.0	23.3	100.0
200224		0.5	56.7	17.6	2.8	10.3	2.5	1.1	1.7	6.2	0.4	0.1	0.0	0.0	25.2	100.0
201153		0.5	57.3	17.8	2.2	8.0	1.9	0.8	2.3	8.5	0.5	0.1	0.1	0.0	24.5	100.0
590118		0.5	58.9	18.3	1.6	5.9	1.4	0.6	2.6	9.4	0.6	0.1	0.1	0.0	22.3	100.0



SITE ID = Colored, bolded, and underlined

NOTES ON THE FORECAST:

1. This projection assumes that no major new traffic generators will be added to the development already included in the 2010/2045 Northeast Regional Travel Demand Model.
2. Design values provided on forecast report are statewide average values. Design values employed in operational analysis are specific to the STH 23 corridor.
3. Single-unit and combination-unit truck percentages were taken from observed 2017 Wisconsin vehicle classification data. Statewide average data (RoadRunner 2016 AC14 report) were used to assign percentages to individual vehicle classifications.
4. From USH 151 to CTH UU, STH 23 is a Factor Group II (Urban-Other) roadway (indicating low to moderate fluctuation in traffic from a seasonal perspective). From CTH UU to CTH P, STH 23 is a Factor Group IV (Rural-Other) roadway (indicating low to moderate fluctuation in traffic from a seasonal perspective). From USH 151 to CTH UU, STH 23 is functionally classified as an Urban Principal Arterial (14) for count purposes. From CTH UU to CTH P, STH 23 is functionally classified as a Rural Principal Arterial (2) for count purposes.
5. The 2010/2045 Northeast Regional Travel Demand Model was used to complete this forecast.
6. With the exception of the STH 23 Majors project (Four-Lane Build Alternative), roadway improvements coded within the existing plus committed (E+C) network of the 2010/2045 Northeast Regional Travel Demand Model were assumed to be in place for the purposes of developing this forecast.

Symbol	Count	Symbol	Forecast
-000-	2017 Count	(000)	2020 AADT
000	2011 Count	[000]	2030 AADT
+000+	2005 Count	000	2040 AADT

WisDOT TRAFFIC FORECAST REPORT

PROJECT ID(S): 1440-13-00 & 1440-15-00

ROUTE(S): STH 23 (Passing Lanes Alternative - NERTDM Only)

Region/COUNTY(IES): NE / Fond du Lac & Sheboygan

LOCATION: USH 151 - CTH P

COMPLETED: April 6, 2018

Developed by: Chris Chritton

Phone: (608) 266-0194

FAX: (608) 267-0294

E-Mail: chris.chritton@dot.wi.gov



Traffic Forecasting Section; Bureau of Planning and Economic Development; Division of Transportation Investment Management

Site(s)	Route(s)	Volume(s)	Site Growth %	Design Values (%)							Truck Classification						
				K250	K100	K30	P	D(Dsgn. Hr.)	T(DHV)	T(PHV)	AADTT	2D	3AX	2S1+2S2	3-S2	DBL-BTM	Total %
201147	STH 23	8520	0.66%	9.3	10.0	10.7	12.4	60/40	19.1	10.2	1680	9.6	2.6	2.1	8.1	0.2	22.7%
206104		8120	0.48%	9.3	10.0	10.7	12.4	60/40	20.6	11.0	1790	10.1	2.8	2.3	9.0	0.2	24.5%
200222		7990	0.34%	9.3	10.0	10.7	12.5	60/40	18.7	10.0	1650	7.5	2.1	2.6	9.9	0.2	22.3%

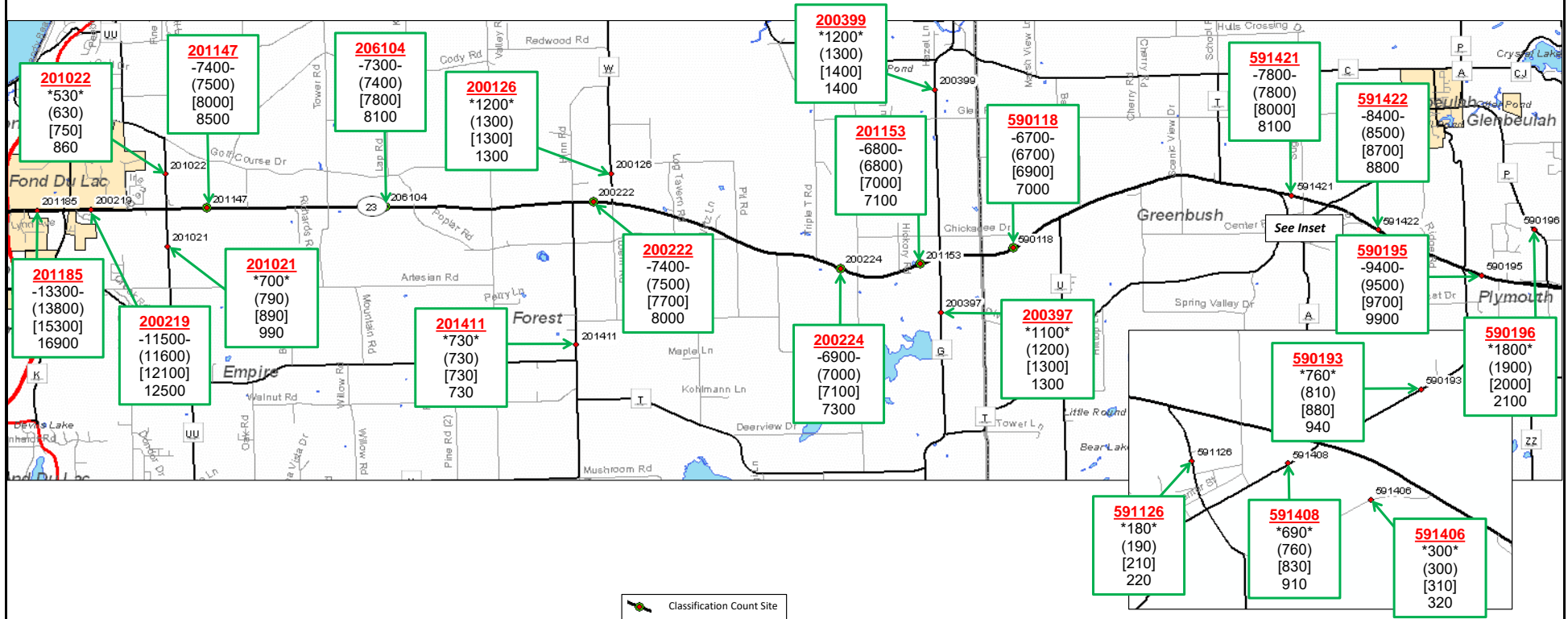

Site(s)	Route(s)	Full Vehicle Classification														TOTAL
		MC	CARS	SU2-4	BUSES	SU2-6	SU3	SU4+	ST4-	ST5	ST6+	MU5-	MU6	MU7+	TRUCKS	
201147	STH 23	0.5	58.6	18.2	2.1	7.6	1.8	0.8	2.1	7.6	0.5	0.1	0.0	0.0	22.7	100.0
206104		0.5	56.4	17.5	2.6	9.5	2.3	1.0	2.1	7.5	0.5	0.1	0.0	0.0	25.7	100.0
200222		0.5	58.2	18.1	2.1	7.7	1.9	0.8	2.2	7.9	0.5	0.1	0.0	0.0	23.3	100.0
200224		0.5	56.7	17.6	2.8	10.3	2.5	1.1	1.7	6.2	0.4	0.1	0.0	0.0	25.2	100.0
201153		0.5	57.3	17.8	2.2	8.0	1.9	0.8	2.3	8.5	0.5	0.1	0.1	0.0	24.5	100.0
590118		0.5	58.9	18.3	1.6	5.9	1.4	0.6	2.6	9.4	0.6	0.1	0.1	0.0	22.3	100.0



SITE ID = Colored, bolded, and underlined

NOTES ON THE FORECAST:

1. This projection assumes that no major new traffic generators will be added to the development already included in the 2010/2045 Northeast Regional Travel Demand Model.
2. Design values provided on forecast report are statewide average values. Design values employed in operational analysis are specific to the STH 23 corridor.
3. Single-unit and combination-unit truck percentages were taken from observed 2017 Wisconsin vehicle classification data. Statewide average data (RoadRunner 2016 AC14 report) were used to assign percentages to individual vehicle classifications.
4. From USH 151 to CTH UU, STH 23 is a Factor Group II (Urban-Other) roadway (indicating low to moderate fluctuation in traffic from a seasonal perspective). From CTH UU to CTH P, STH 23 is a Factor Group IV (Rural-Other) roadway (indicating low to moderate fluctuation in traffic from a seasonal perspective). From USH 151 to CTH UU, STH 23 is functionally classified as an Urban Principal Arterial ([14] - in the STH 23 Majors - Passing Lanes Alternative) for count purposes. From CTH UU to CTH P, STH 23 is functionally classified as a Rural Principal Arterial ([2] in the STH 23 Majors - Passing Lanes Alternative) for count purposes.
5. The 2010/2045 Northeast Regional Travel Demand Model was used to complete this forecast.
6. Roadway improvements coded within the existing plus committed (E+C) network of the 2010/2045 Northeast Regional Travel Demand Model (in addition to the STH 23 Majors Project - Passing Lanes Alternative) were assumed to be in place for the purposes of developing this forecast.

Symbol	Count	Symbol	Forecast
-000-	2017 Count	(000)	2020 AADT
000	2011 Count	[000]	2030 AADT
		000	2040 AADT

WisDOT TRAFFIC FORECAST REPORT

Region/COUNTY(IES): NE / Fond du Lac & Sheboygan

Developed by: Chris Chritton



PROJECT ID(S): 1440-13-00 & 1440-15-00

LOCATION: USH 151 - CTH P

Phone: (608) 266-0194

ROUTE(S): STH 23 (Hybrid Alternative - NERTDM Only)

COMPLETED: April 6, 2018

FAX: (608) 267-0294

E-Mail: chris.chritton@dot.wi.gov

Traffic Forecasting Section; Bureau of Planning and Economic Development; Division of Transportation Investment Management

Site(s)	Route(s)	Design Values (%)										Truck Classification					
		Volume(s)	Site Growth %	K250	K100	K30	P	D(Dsgn. Hr.)	T(DHV)	T(PHV)	AADTT	2D	3AX	2S1+2S2	3-S2	DBL-BTM	Total %
201147	STH 23	11030	2.14%	10.0	11.2	12.2	14.9	60/40	19.1	10.2	1680	9.6	2.6	2.1	8.1	0.2	22.7%
206104		10800	2.07%	10.0	11.2	12.2	14.9	60/40	20.6	11.0	1790	10.1	2.8	2.3	9.0	0.2	24.5%
200222		10290	1.69%	10.0	11.2	12.3	15.0	60/40	18.7	10.0	1650	7.5	2.1	2.6	9.9	0.2	22.3%

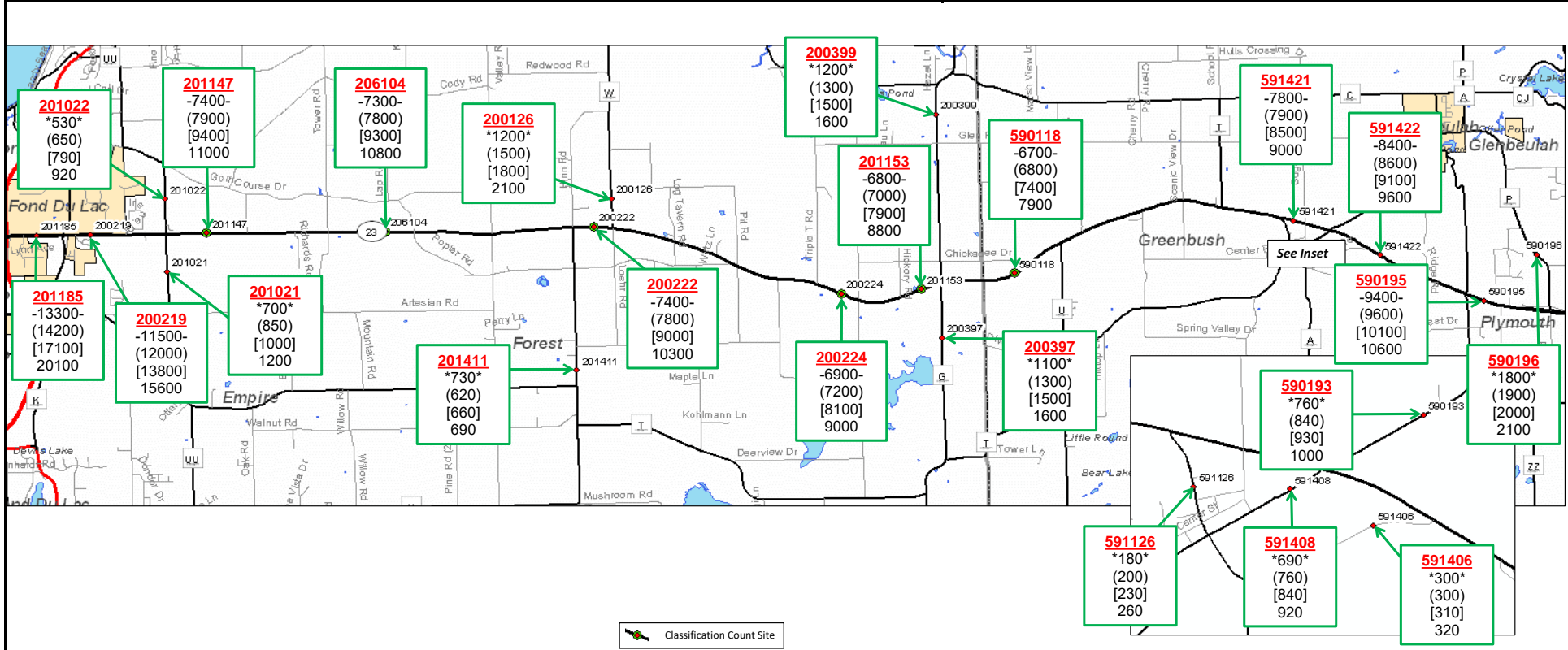

Site(s)	Route(s)	Full Vehicle Classification														TOTAL
		MC	CARS	SU2-4	BUSES	SU2-6	SU3	SU4+	ST4-	ST5	ST6+	MU5-	MU6	MU7+	TRUCKS	
201147	STH 23	0.5	58.6	18.2	2.1	7.6	1.8	0.8	2.1	7.6	0.5	0.1	0.0	0.0	22.7	100.0
206104		0.5	56.4	17.5	2.6	9.5	2.3	1.0	2.1	7.5	0.5	0.1	0.0	0.0	25.7	100.0
200222		0.5	58.2	18.1	2.1	7.7	1.9	0.8	2.2	7.9	0.5	0.1	0.0	0.0	23.3	100.0
200224		0.5	56.7	17.6	2.8	10.3	2.5	1.1	1.7	6.2	0.4	0.1	0.0	0.0	25.2	100.0
201153		0.5	57.3	17.8	2.2	8.0	1.9	0.8	2.3	8.5	0.5	0.1	0.1	0.0	24.5	100.0
590118		0.5	58.9	18.3	1.6	5.9	1.4	0.6	2.6	9.4	0.6	0.1	0.1	0.0	22.3	100.0

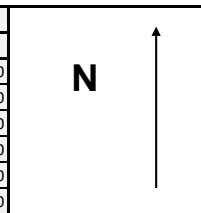

SITE ID = Colored, bolded, and underlined

NOTES ON THE FORECAST:

Symbol	Count	Symbol	Forecast
-000-	2017 Count	(000)	2020 AADT
000	2011 Count	[000]	2030 AADT
		000	2040 AADT

1. This projection assumes that no major new traffic generators will be added to the development already included in the 2010/2045 Northeast Regional Travel Demand Model.
2. Design values provided on forecast report are statewide average values. Design values employed in operational analysis are specific to the STH 23 corridor.
3. Single-unit and combination-unit truck percentages were taken from observed 2017 Wisconsin vehicle classification data. Statewide average data (RoadRunner 2016 AC14 report) were used to assign percentages to individual vehicle classifications.
4. From USH 151 to CTH UU, STH 23 is a Factor Group II (Urban-Other) roadway (indicating low to moderate fluctuation in traffic from a seasonal perspective). From CTH UU to CTH P, STH 23 is a Factor Group IV (Rural-Other) roadway (indicating low to moderate fluctuation in traffic from a seasonal perspective). From USH 151 to CTH G, STH 23 is functionally classified as an expressway [4] in the STH 23 Majors - Hybrid Alternative) for count purposes. From CTH G to CTH P, STH 23 is functionally classified as a Rural Principal Arterial [2] in the STH 23 Majors - Hybrid Alternative) for count purposes.
5. The 2010/2045 Northeast Regional Travel Demand Model was used to complete this forecast.
6. Roadway improvements coded within the existing plus committed (E+C) network of the 2010/2045 Northeast Regional Travel Demand Model (in addition to the STH 23 Majors Project - Hybrid Alternative) were assumed to be in place for the purposes of developing this forecast.

WisDOT TRAFFIC FORECAST REPORT

Region/COUNTY(IES): NE / Fond du Lac & Sheboygan

Developed by: Chris Chritton
 Phone: (608) 266-0194
 FAX: (608) 267-0294
 E-Mail: chris.chritton@dot.wi.gov



PROJECT ID(S): 1440-13-00 & 1440-15-00

LOCATION: USH 151 - CTH P

ROUTE(S): STH 23 (Four-Lane Build Alternative - NERTDM Only)

COMPLETED: April 6, 2018

Traffic Forecasting Section; Bureau of Planning and Economic Development; Division of Transportation Investment Management

Site(s)	Route(s)	Volume(s)	Site Growth %	Design Values (%)							Truck Classification						
				K250	K100	K30	P	D(Dsgn. Hr.)	T(DHV)	T(PHV)	AADTT	2D	3AX	2S1+2S2	3-S2	DBL-BTM	Total %
201147	STH 23	11940	2.67%	9.9	11.1	12.1	14.8	60/40	19.1	10.2	1680	9.6	2.6	2.1	8.1	0.2	22.7%
206104		11730	2.62%	9.9	11.1	12.1	14.8	60/40	21.6	11.6	1880	12.1	3.3	2.1	8.0	0.2	25.7%
200222		11230	2.24%	10.0	11.2	12.2	14.8	60/40	19.6	10.5	1730	9.8	2.7	2.2	8.4	0.2	23.3%

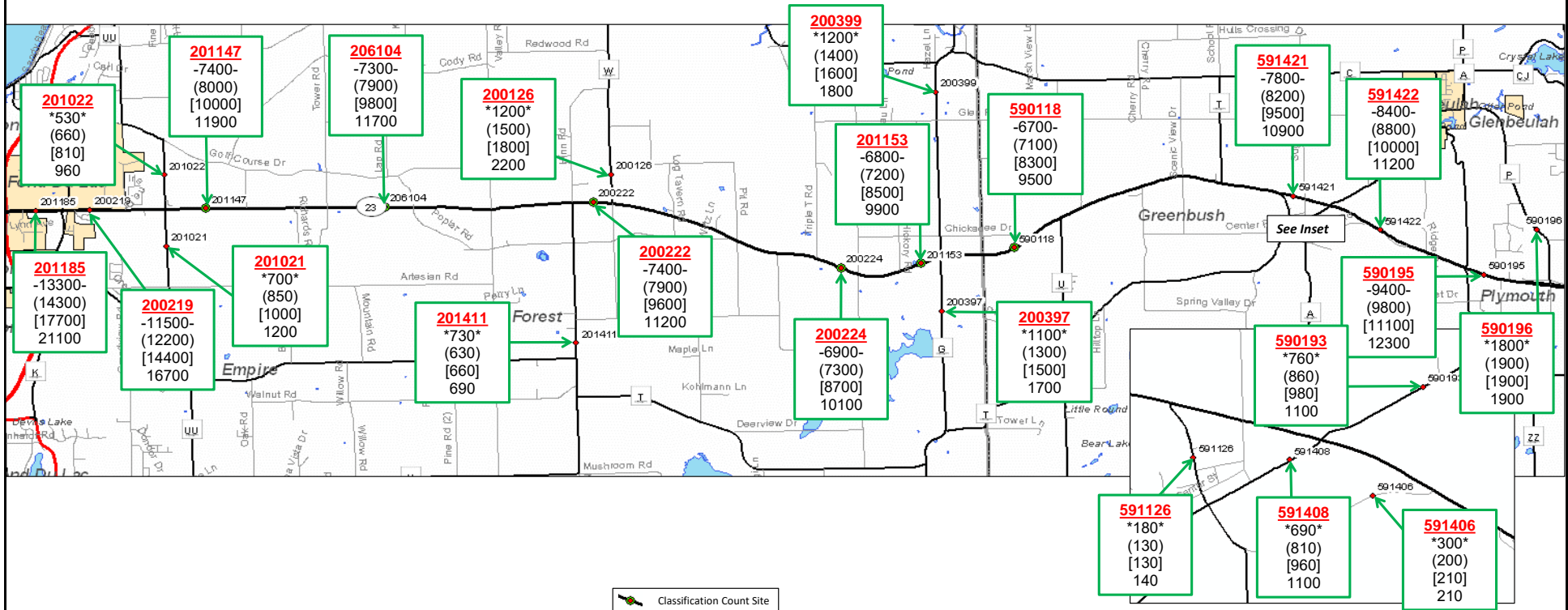

Full Vehicle Classification																
Site(s)	Route(s)	MC	CARS	SU2-4	BUSES	SU2-6	SU3	SU4+	ST4-	ST5	ST6+	MU5-	MU6	MU7+	TRUCKS	TOTAL
201147	STH 23	0.5	58.6	18.2	2.1	7.6	1.8	0.8	2.1	7.6	0.5	0.1	0.0	0.0	22.7	100.0
206104		0.5	56.4	17.5	2.6	9.5	2.3	1.0	2.1	7.5	0.5	0.1	0.0	0.0	25.7	100.0
200222		0.5	58.2	18.1	2.1	7.7	1.9	0.8	2.2	7.9	0.5	0.1	0.0	0.0	23.3	100.0
200224		0.5	56.7	17.6	2.8	10.3	2.5	1.1	1.7	6.2	0.4	0.1	0.0	0.0	25.2	100.0
201153		0.5	57.3	17.8	2.2	8.0	1.9	0.8	2.3	8.5	0.5	0.1	0.1	0.0	24.5	100.0
590118		0.5	58.9	18.3	1.6	5.9	1.4	0.6	2.6	9.4	0.6	0.1	0.1	0.0	22.3	100.0

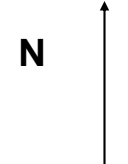

Symbol	Count	Symbol	Forecast
-000-	2017 Count	(000)	2020 AADT
000	2011 Count	[000]	2030 AADT
+000+	2005 Count	000	2040 AADT

NOTES ON THE FORECAST:

- This projection assumes that no major new traffic generators will be added to the development already included in the 2010/2045 Northeast Regional Travel Demand Model.
- Design values provided on forecast report are statewide average values. Design values employed in operational analysis are specific to the STH 23 corridor.
- Single-unit and combination-unit truck percentages were taken from observed 2017 Wisconsin vehicle classification data. Statewide average data (RoadRunner 2016 AC14 report) were used to assign percentages to individual vehicle classifications.
- From USH 151 to CTH UU, STH 23 is a Factor Group II (Urban-Other) roadway (indicating low to moderate fluctuation in traffic from a seasonal perspective). From CTH UU to CTH P, STH 23 is a Factor Group IV (Rural-Other) roadway (indicating low to moderate fluctuation in traffic from a seasonal perspective). From USH 151 to CTH P, STH 23 is functionally classified as an expressway (in the STH 23 Majors - Four-Lane Build Alternative) for count purposes.
- The 2010/2045 Northeast Regional Travel Demand Model was used to complete this forecast.
- Roadway improvements coded within the existing plus committed (E+C) network of the 2010/2045 Northeast Regional Travel Demand Model (including the STH 23 Majors Project - Four-Lane Build) were assumed to be in place for the purposes of developing this forecast.

ATTACHMENT D
ACCESS DENSITY CALCULATIONS

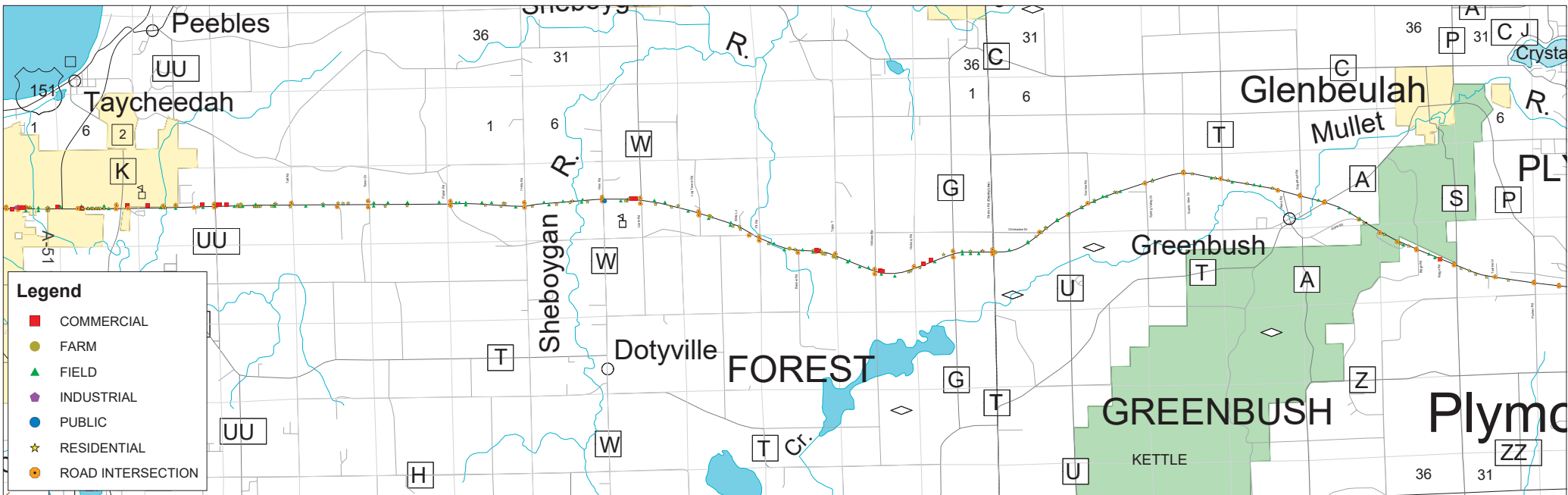

FOREST

GREENBUSH

KETTLE

Plymou

Crysta R.

Mullet R.

Sheboygan R.

Peebles

Taycheedah

Glenbeulah

Dotyville

Greenbush

Legend

- COMMERCIAL
- FARM
- FIELD
- INDUSTRIAL
- PUBLIC
- RESIDENTIAL
- ROAD INTERSECTION

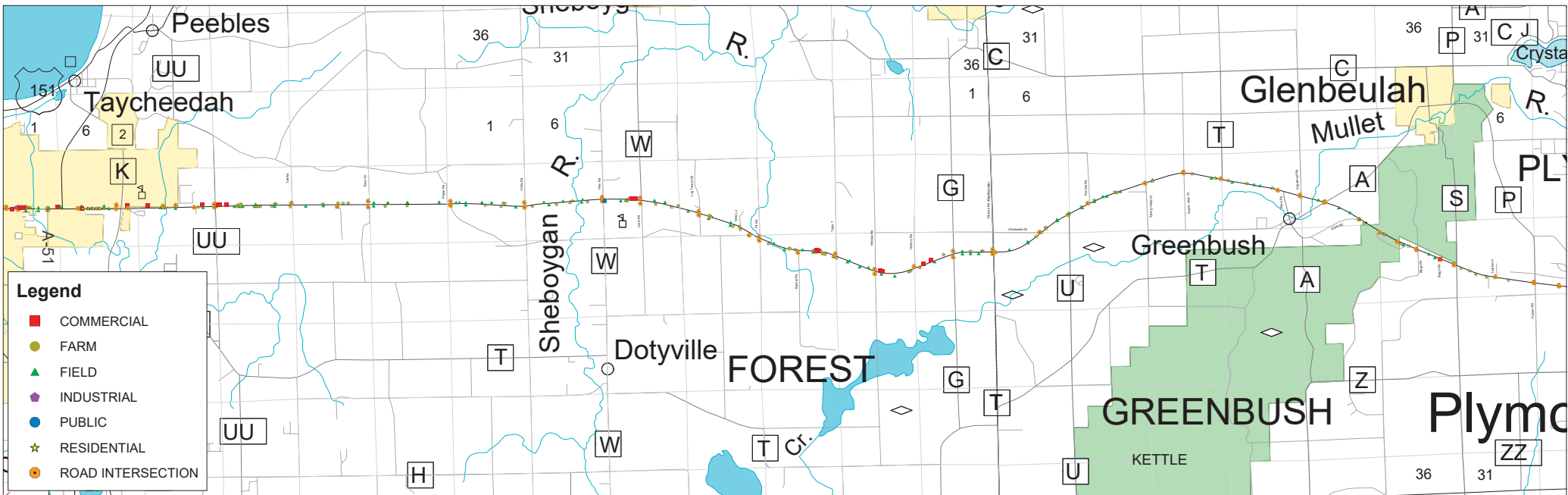

WIS 23 Two-Lane Highway Analysis: Access Point Summary

October 2, 2017

"starting" limit included in each segment

Access Point Summary: EB Analyses

Sideroads or Landmarks		Lengths by Stations			# of Access Points	Access Points	
Start	End	STA (start)	STA (end)	Total (ft)		Dist (mi)	per Mile
CTH UU	Tower Rd	203+50	308+40	10,490	32	2.0	16
Tower Rd	2A start	308+40	325+00	1,660	6	0.3	19
2A start	2A end	325+00	382+00	5,700	9	1.1	8
2A end	7 Hills Rd	382+00	415+00	3,300	9	0.6	14
Tower Rd	7 Hills Rd	308+40	415+00	10,660	24	2.0	12
7 Hills Rd	W (S)	415+00	468+00	5,300	12	1.0	12
W (S)	W (N)	468+00	494+25	2,625	9	0.5	18
W (N)	Log Tavern	494+25	535+10	4,085	8	0.8	10
Log Tavern	Pit	535+10	580+00	4,490	11	0.9	13
Pit	Banner	580+00	607+60	2,760	7	0.5	13
Banner	Triple T	607+60	633+50	2,590	11	0.5	22
Triple T	Hillview	633+50	662+60	2,910	6	0.6	11
Hillview	CTH G	662+60	718+50	5,590	14	1.1	13
CTH G	2C start	718+50	730+90	1,240	6	0.2	26
2C start	2C end	730+90	793+80	6,290	14	1.2	12
2C end	CTH U	793+80	804+50	1,070	2	0.2	10
CTH G	Division Rd	718+50	745+50	2,700	9	0.5	18
Division Rd	CTH U	745+50	804+50	5,900	13	1.1	12
CTH U	Spring Valley Dr	804+50	861+25	5,675	12	1.1	11
Spring Valley Dr	Scenic View Dr	861+25	888+80	2,755	4	0.5	8
Scenic View Dr	CTH T (N)	888+80	914+90	2,610	5	0.5	10
CTH T (N)	Sugarbush Rd	914+90	970+10	5,520	8	1.0	8
Sugarbush Rd	CTH A	970+10	988+00	1,790	3	0.3	9
CTH A	CL start	988+00	1018+00	3,000	8	0.6	14
CL start	CL end	1018+00	1058+00	4,000	6	0.8	8
CL end	CTH S	1058+00	1086+00	2,800	5	0.5	9
CTH S	W of CTH P	1086+00	1126+50	4,050	8	0.8	10
No-Build - CTH UU to CTH G					134	10	14
No-Build - CTH G to Climbing Lane Start					62	6	11
No-Build - Climbing Lane Analysis: CTH G to W of CTH P					81	8	10
Passing Lane Alt 2A - CTH UU to CTH G					134	10	14
Passing Lane Alt 2C - End of 2A to Climbing Lane Start					149	12	12
Passing Lane Alt - Climbing Lane Analysis: End of 2C to W of CTH P					61	6	10
Hybrid Alt - CTH UU to CTH G (4-Lane)					---	---	---
Hybrid Alt 2C - CTH G to Climbing Lane Start					62	6	11
Hybrid Alt - Climbing Lane Analysis: End of 2C to W of CTH P					61	6	10

Note: Starting sideroad included in each segment, counted from west to east.

WIS 23 Two-Lane Highway Analysis: Access Point Summary

October 2, 2017

"starting" limit included in each segment

Access Point Summary: WB Analyses

Sideroads or Landmarks		Lengths by Stations			# of Access Points	Access Points	
Start	End	STA (start)	STA (end)	Total (ft)		Dist (mi)	per Mile
CTH UU	Tower Rd	203+50	308+40	10,490	32	2.0	16
Tower Rd	7 Hills Rd	308+40	415+00	10,660	24	2.0	12
7 Hills Rd	W (S)	415+00	468+00	5,300	12	1.0	12
W (S)	W (N)	468+00	494+25	2,625	9	0.5	18
W (N)	Log Tavern	494+25	535+10	4,085	8	0.8	10
Log Tavern	Pit	535+10	580+00	4,490	11	0.9	13
Log Tavern	2B end	535+10	550+50	1,540	5	0.3	17
2B end	2B start	550+50	618+00	6,750	18	1.3	14
2B start	Triple T	618+00	633+50	1,550	6	0.3	20
Pit	Banner	580+00	607+60	2,760	7	0.5	13
Banner	Triple T	607+60	633+50	2,590	11	0.5	22
Triple T	Hillview	633+50	662+60	2,910	6	0.6	11
Hillview	CTH G	662+60	718+50	5,590	14	1.1	13
CTH G	Division Rd	718+50	745+50	2,700	9	0.5	18
Division Rd	CTH U	745+50	804+50	5,900	13	1.1	12
CTH U	Spring Valley Dr	804+50	861+25	5,675	12	1.1	11
CTH U	2D end	804+50	848+65	4,415	12	0.8	14
2D end	2D start	848+65	907+65	5,900	7	1.1	6
2D start	CTH T (N)	907+65	914+90	725	2	0.1	15
Spring Valley Dr	Scenic View Dr	861+25	888+80	2,755	4	0.5	8
Scenic View Dr	CTH T (N)	888+80	914+90	2,610	5	0.5	10
CTH T (N)	Sugarbush Rd	914+90	970+10	5,520	8	1.0	8
Sugarbush Rd	CTH A	970+10	988+00	1,790	3	0.3	9
CTH A	CL end (Ridge)	988+00	1058+00	7,000	14	1.3	11
CL end	CTH S	1058+00	1086+00	2,800	5	0.5	9
CTH S	CL start (Twinkle)	1086+00	1115+00	2,900	6	0.5	11
Twinkle	W of CTH P	1115+00	1126+50	1,150	2	0.2	9
No-Build - CTH G to CTH UU					134	10	14
No-Build - Climbing Lane End to CTH G					68	6	11
No-Build - Climbing Lane Analysis: Twinkle to Ridge					11	1	10
Passing Lane Alt 2B - CTH G to CTH UU					134	10	14
Passing Lane Alt 2D - Climbing Lane End to Start of 2B					94	8	11
Passing Lane Alt - Climbing Lane Analysis: Twinkle to Ridge					11	1	10
Hybrid Alt - CTH G to CTH UU (4-Lane)					---	---	---
Hybrid Alt 2D - Climbing Lane End to CTH G					68	6	11
Hybrid Alt - Climbing Lane Analysis: Twinkle to Ridge					11	1	10

Note: Starting sideroad included in each segment, counted from west to east.

**ATTACHMENT E
NO-PASSING ZONE CALCULATIONS**

WIS 23 Two-Lane Highway Analysis: No-Passing Zone Summary

October 2, 2017

Eastbound No-Passing Zone Calcs

Sideroads or Landmarks		Lengths by Stations			Measured from Google Aerials and Street View (Nov 2016)								Total Distances (ft)			No Passing %				
Start	End	STA (start)	STA (end)	Total (ft)	Length 1 (ft) Westernmost	Length 2 (ft)	Length 3 (ft)	Length 4 (ft)	Length 5 (ft)	Length 6 (ft)	Length 7 (ft)	Length 8 (ft)	Passing	No Passing	Total					
CTH UU	Tower Rd	203+50	308+40	10,490	1,050	NP	3,360	Pass	820	NP	2,150	Pass	880	NP	2,230	Pass	7,740	2,750	10,490	26%
Tower Rd	2A start	308+40	325+00	1,660	1,660	Pass											1,660	0	1,660	0%
2A start	2A end	325+00	382+00	5,700	2,320	Pass	1,400	NP	1,700	Pass	280	NP					4,020	1,680	5,700	29%
2A end	7 Hills Rd	382+00	415+00	3,300	3,300	NP											0	3,300	3,300	100%
Tower Rd	7 Hills Rd	308+40	415+00	10,660	1,660	Pass	2,320	Pass	1,400	NP	1,700	Pass	3,580	NP			5,680	4,980	10,660	47%
7 Hills Rd	W (S)	415+00	468+00	5,300	770	NP	4,460	Pass	70	NP							4,460	840	5,300	16%
W (S)	W (N)	468+00	494+25	2,625	2,625	NP											0	2,625	2,625	100%
W (N)	Log Tavern	494+25	535+10	4,085	240	NP	2,180	Pass	1,665	NP							2,180	1,905	4,085	47%
Log Tavern	Pit	535+10	580+00	4,490	1,660	Pass	1,230	NP	1,600	Pass							3,260	1,230	4,490	27%
Pit	Banner	580+00	607+60	2,760	690	Pass	1,540	NP	530	Pass							1,220	1,540	2,760	56%
Banner	Triple T	607+60	633+50	2,590	440	Pass	2,150	NP									440	2,150	2,590	83%
Triple T	Hillview	633+50	662+60	2,910	1,740	Pass	1,170	NP									1,740	1,170	2,910	40%
Hillview	CTH G	662+60	718+50	5,590	2,740	NP	1,650	Pass	1,200	NP							1,650	3,940	5,590	70%
CTH G	2C start	718+50	730+90	1,240	1,240	NP											0	1,240	1,240	100%
2C start	2C end	730+90	793+80	6,290	1,460	NP	2,110	NP	1,330	Pass	1,160	NP	230	Pass			1,560	4,730	6,290	75%
2C end	CTH U	793+80	804+50	1,070	1,070	Pass											1,070	0	1,070	0%
CTH G	Division Rd	718+50	745+50	2,700	2,700	NP											0	2,700	2,700	100%
Division Rd	CTH U	745+50	804+50	5,900	2,110	NP	1,330	Pass	1,160	NP	1,300	Pass					2,630	3,270	5,900	55%
CTH U	Spring Valley Dr	804+50	861+25	5,675	5,675	Pass											5,675	0	5,675	0%
Spring Valley Dr	Scenic View Dr	861+25	888+80	2,755	170	Pass	2,585	NP									170	2,585	2,755	94%
Scenic View Dr	CTH T (N)	888+80	914+90	2,610	520	NP	2,090	Pass									2,090	520	2,610	20%
CTH T (N)	Sugarbush Rd	914+90	970+10	5,520	5,520	Pass											5,520	0	5,520	0%
Sugarbush Rd	CTH A	970+10	988+00	1,790	1,790	Pass											1,790	0	1,790	0%
CTH A	CL start	988+00	1018+00	3,000	2,490	Pass	510	NP									2,490	510	3,000	17%
CL start	CL end	1018+00	1058+00	4,000	4,000	NP											0	4,000	4,000	100%
CL end	CTH S	1058+00	1086+00	2,800	2,800	NP											0	2,800	2,800	100%
CTH S	W of CTH P	1086+00	1126+50	4,050	4,050	NP											0	4,050	4,050	100%
													<i>No-Build - CTH UU to CTH G</i>			28,370	23,130	51,500	45%	
													<i>No-Build - CTH G to Climbing Lane Start</i>			20,365	9,585	29,950	32%	
													<i>No-Build - Climbing Lane Analysis: CTH G to W of CTH P</i>			20,365	20,435	40,800	50%	
													<i>Passing Lane Alt 2A - CTH UU to CTH G</i>			28,370	23,130	51,500	45%	
													<i>Passing Lane Alt 2C - End of 2A to Climbing Lane Start</i>			35,315	28,285	63,600	44%	
													<i>Passing Lane Alt - Climbing Lane Analysis: End of 2C to W of CTH P</i>			18,805	14,465	33,270	43%	
													<i>Hybrid Alt - CTH UU to CTH G (4-Lane)</i>			---	---	---	---	
													<i>Hybrid Alt 2C - CTH G to Climbing Lane Start</i>			---	---	---	---	
													<i>Hybrid Alt - Climbing Lane Analysis: End of 2C to W of CTH P</i>			18,805	14,465	33,270	43%	

A-55

WIS 23 Two-Lane Highway Analysis: No-Passing Zone Summary

October 2, 2017

Westbound No-Passing Zone Calcs

Sideroads or Landmarks		Lengths by Stations			Measured from Google Aerials and Street View (Nov 2016)										Total Distances (ft)			No Passing %						
Start	End	STA (start)	STA (end)	Total (ft)	Length 1 (ft) <i>Easternmost</i>		Length 2 (ft)		Length 3 (ft)		Length 4 (ft)		Length 5 (ft)		Length 6 (ft)		Length 7 (ft)		Length 8 (ft)		Passing	No Passing	Total	
CTH UU	Tower Rd	203+50	308+40	10,490	860	Pass	1,280	NP	3,060	Pass	2,830	Pass	2,460	NP							6,750	3,740	10,490	36%
Tower Rd	7 Hills Rd	308+40	415+00	10,660	2,210	NP	1,670	Pass	1,340	NP	5,440	Pass									7,110	3,550	10,660	33%
7 Hills Rd	W (S)	415+00	468+00	5,300	3,160	Pass	2,140	NP													3,160	2,140	5,300	40%
W (S)	W (N)	468+00	494+25	2,625	1,300	NP	1,325	NP													0	2,625	2,625	100%
W (N)	Log Tavern	494+25	535+10	4,085	200	NP	2,280	Pass	1,605	NP											2,280	1,805	4,085	44%
Log Tavern	Pit	535+10	580+00	4,490	1,680	NP	1,440	Pass	1,370	NP											1,440	3,050	4,490	68%
Log Tavern	2B end	535+10	550+50	1,540	1,540	NP															0	1,540	1,540	100%
2B end	2B start	550+50	618+00	6,750	290	Pass	750	NP	330	NP	1,680	Pass	750	NP	1,370	NP	1,440	Pass	140	NP	3,410	3,340	6,750	49%
2B start	Triple T	618+00	633+50	1,550	940	NP	610	Pass													610	940	1,550	61%
Pit	Banner	580+00	607+60	2,760	750	NP	1,680	Pass	330	NP											1,680	1,080	2,760	39%
Banner	Triple T	607+60	633+50	2,590	750	NP	900	Pass	940	NP											900	1,690	2,590	65%
Triple T	Hillview	633+50	662+60	2,910	1,500	Pass	1,410	NP													1,500	1,410	2,910	48%
Hillview	CTH G	662+60	718+50	5,590	2,270	Pass	3,120	NP	200	Pass											2,470	3,120	5,590	56%
CTH G	Division Rd	718+50	745+50	2,700	2,530	NP	170	Pass													170	2,530	2,700	94%
Division Rd	CTH U	745+50	804+50	5,900	990	NP	1,310	Pass	3,600	NP											1,310	4,590	5,900	78%
CTH U	Spring Valley Dr	804+50	861+25	5,675	5,525	Pass	150	NP													5,525	150	5,675	3%
CTH U	2D end	804+50	848+65	4,415	4,265	Pass	150	NP													4,265	150	4,415	3%
2D end	2D start	848+65	907+65	5,900	1,260	Pass	1,120	NP	2,135	Pass	1,385	NP									3,395	2,505	5,900	42%
2D start	CTH T (N)	907+65	914+90	725	725	NP															0	725	725	100%
Spring Valley Dr	Scenic View Dr	861+25	888+80	2,755	1,120	NP	1,635	Pass													1,635	1,120	2,755	41%
Scenic View Dr	CTH T (N)	888+80	914+90	2,610	500	Pass	2,110	NP													500	2,110	2,610	81%
CTH T (N)	Sugarbush Rd	914+90	970+10	5,520	5,520	Pass															5,520	0	5,520	0%
Sugarbush Rd	CTH A	970+10	988+00	1,790	1,790	Pass															1,790	0	1,790	0%
CTH A	CL end (Ridge)	988+00	1058+00	7,000	340	Pass	1,550	NP	5,110	Pass											5,450	1,550	7,000	22%
CL end	CTH S	1058+00	1086+00	2,800	2,320	NP	480	Pass													480	2,320	2,800	83%
CTH S	CL start (Twinkle)	1086+00	1115+00	2,900	2,900	NP															0	2,900	2,900	100%
Twinkle	W of CTH P	1115+00	1126+50	1,150	1,150	NP															0	1,150	1,150	100%
No-Passing Zone Calculations for HCS Analysis											<i>No-Build - CTH G to CTH UU</i>										27,290	24,210	51,500	47%
											<i>No-Build - Climbing Lane End to CTH G</i>										21,900	12,050	33,950	35%
											<i>No-Build - Climbing Lane Analysis: Twinkle to Ridge</i>										480	5,220	5,700	92%
											<i>Passing Lane Alt 2B - CTH G to CTH UU</i>										27,290	24,210	51,500	47%
											<i>Passing Lane Alt 2D - Climbing Lane End to Start of 2B</i>										26,480	17,520	44,000	40%
											<i>Passing Lane Alt - Climbing Lane Analysis: Twinkle to Ridge</i>										480	5,220	5,700	92%
											<i>Hybrid Alt - CTH G to CTH UU (4-Lane)</i>										---	---	---	---
											<i>Hybrid Alt 2D - Climbing Lane End to CTH G</i>										---	---	---	---
											<i>Hybrid Alt - Climbing Lane Analysis: Twinkle to Ridge</i>										480	5,220	5,700	92%

A-57

ATTACHMENT F
PROJECTED INTERSECTION VOLUMES

WIS 23/CTH UU Intersection Forecast Volumes

April 9, 2018

2040 No Build: AM Peak
 Intersection volumes from WisDOT forecast (4-6-2018)

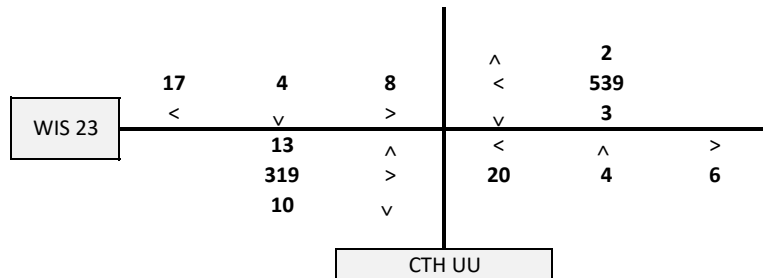

2040 No Build: PM Peak
 Intersection volumes from WisDOT forecast (4-6-2018)

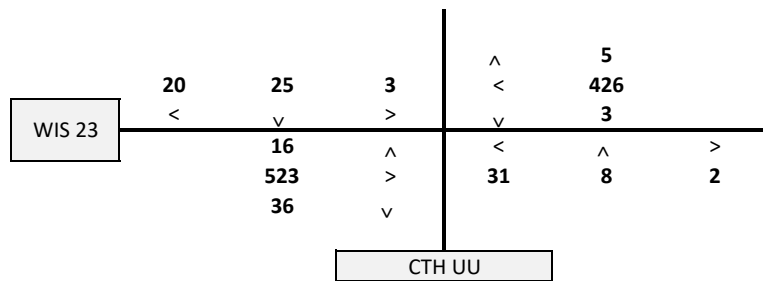

2040 Passing Lane Alt: AM Peak
 Intersection volumes factored up based on WIS 23 mainline trends

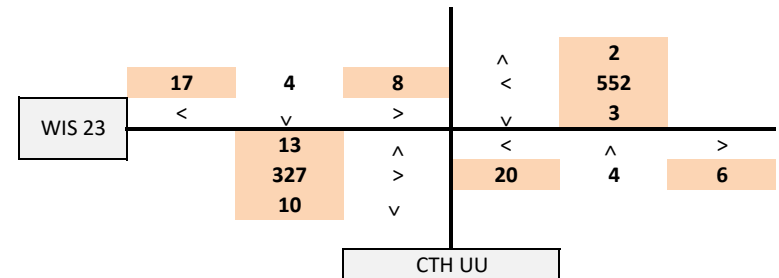

2040 Passing Lane Alt: PM Peak
 Intersection volumes factored up based on WIS 23 mainline trends

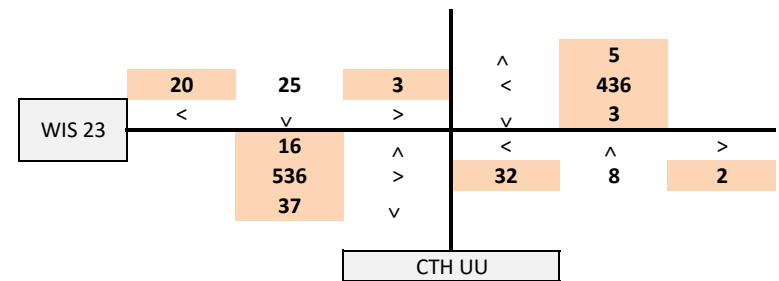

A-60

Location		2040 AADT		Growth Factor
		No-Build	Passing Lane	
Site 201147	CTH UU to Tower	8,300	8,500	2.4%
		Average		2.4%

Note: Site east of CTH K not used due to access changes as part of passing lane alternative.

WIS 23/CTH W (N) Intersection Forecast Volumes

April 9, 2018

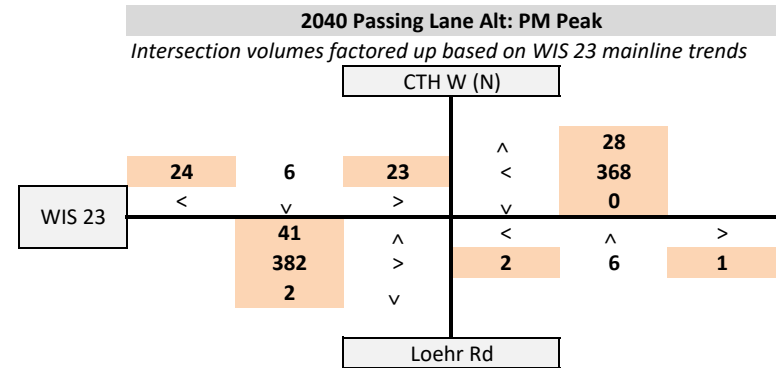
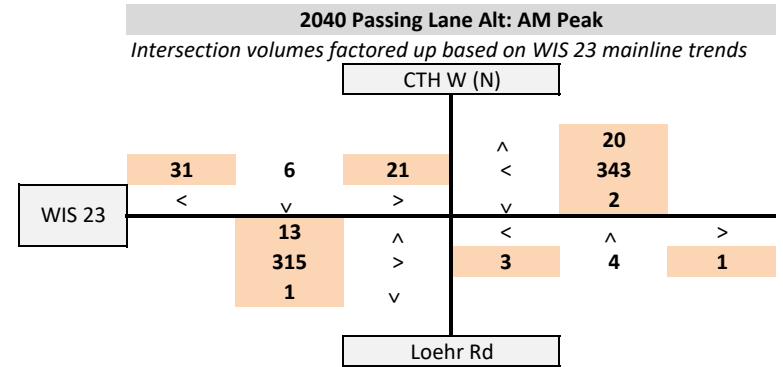
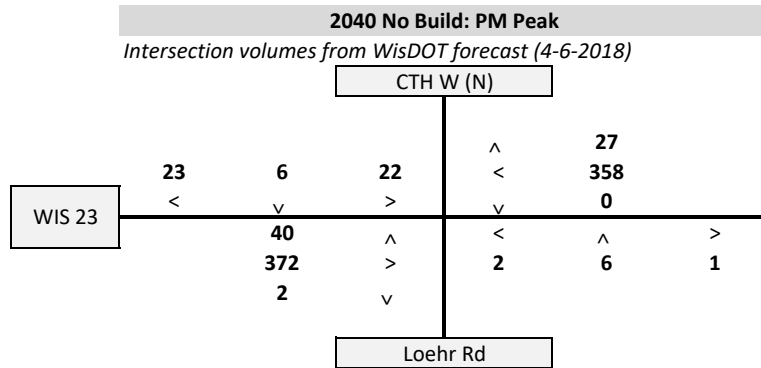
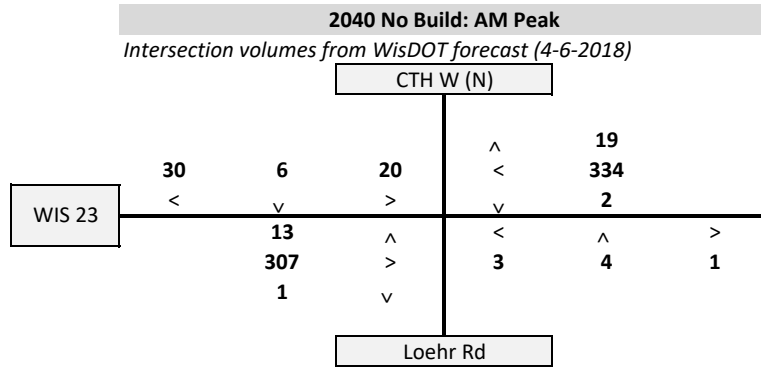

A-61

Location		2040 AADT		Growth Factor
		No-Build	Passing Lane	
Site 200222	W (S) to W (N)	7,800	8,000	2.6%
Site 200224	W (N) to Hillview	7,100	7,300	2.8%
		Average		2.7%

WIS 23/CTH G Intersection Forecast Volumes

April 9, 2018

2040 No Build: AM Peak
Intersection volumes from WisDOT forecast (4-6-2018)

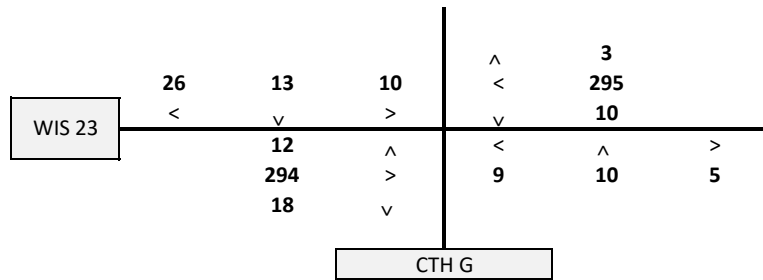

2040 No Build: PM Peak
Intersection volumes from WisDOT forecast (4-6-2018)

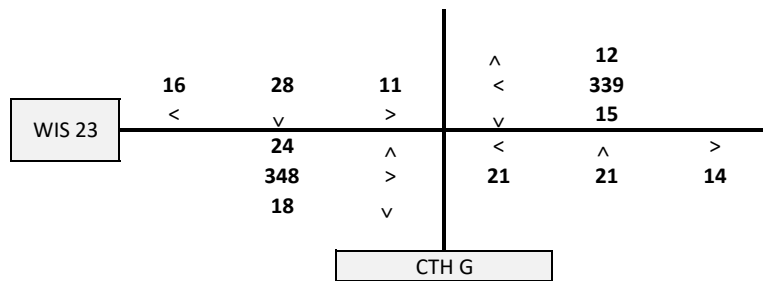

2040 Passing Lane Alt: AM Peak
Intersection volumes factored up based on WIS 23 mainline trends

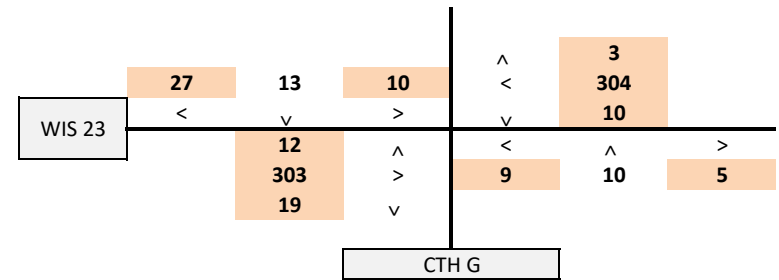

2040 Passing Lane Alt: PM Peak
Intersection volumes factored up based on WIS 23 mainline trends

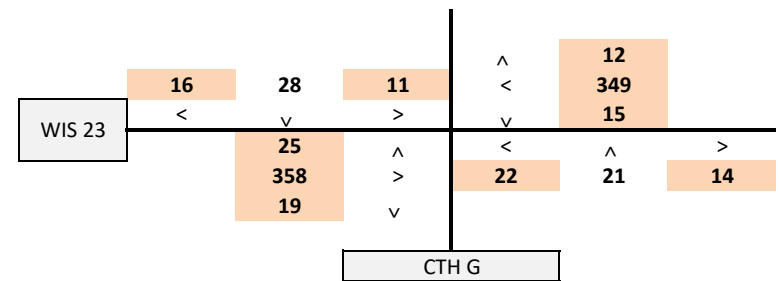

A-62

Location		2040 AADT		Growth Factor
		No-Build	Passing Lane	
Site 201153	Hillview to CTH G	6,900	7,100	2.9%
Site 590118	CTH G to CTH T (N)	6,800	7,000	2.9%
		Average		2.9%

WIS 23/CTH W - J-Turn Volume development (4-Lane On-Alignment and Hybrid)

April 9, 2018

AM PEAK HOUR

4-lane On-Alignment Alternative Volumes (2040)

Intersection volumes from WisDOT forecast (4-6-2018)

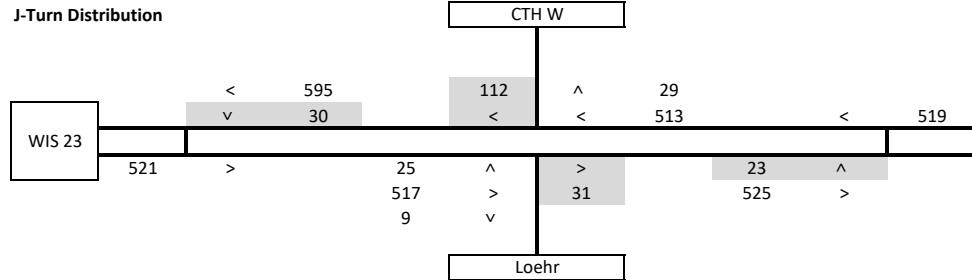
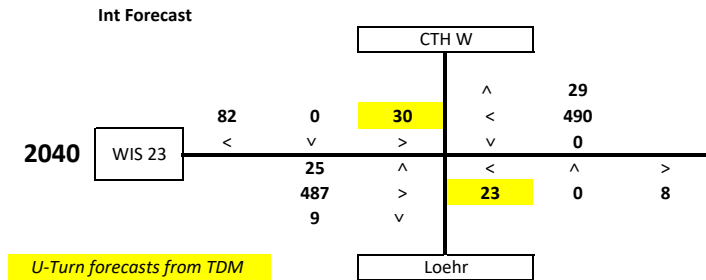

4-lane On-Alignment and Hybrid Reduction Factor Development

Location		2040 AADT		Factor
		4-Lane	Hybrid	
Site 200222	West of CTH W/Loehr	11,200	10,300	92.0%
Site 200224	East of CTH W/Loehr	10,100	9,000	89.1%
Average				90.5%

U-Turn Heavy Truck% 7.7%
 Critical Headway 4.55 s
 Follow Up Headway 2.68 s
 CTH W to west U-Turn 1,300 ft
 WB U-Turn storage 450 ft

U-Turn Heavy Truck% 0.0%
 Critical Headway 4.40 s
 Follow Up Headway 2.60 s
 Loehr Rd to east U-Turn 1,150 ft
 EB U-Turn storage 450 ft

Note: EB to WB U-turn includes CTH W/Hinn NBL & NBT in truck % calc.

Hybrid Alternative Factored Volumes (2040)

Intersection volumes factored down based on WIS 23 mainline trends

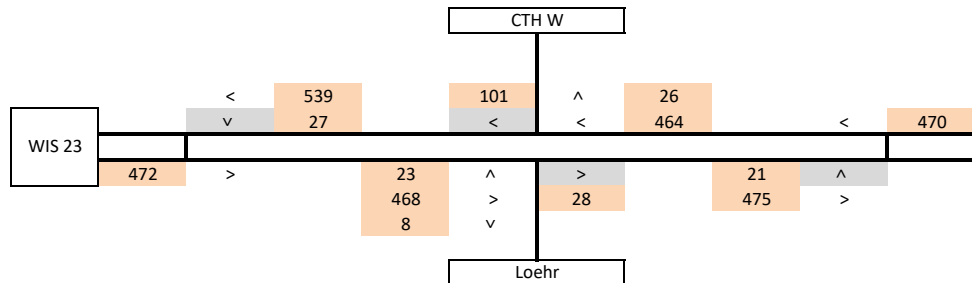
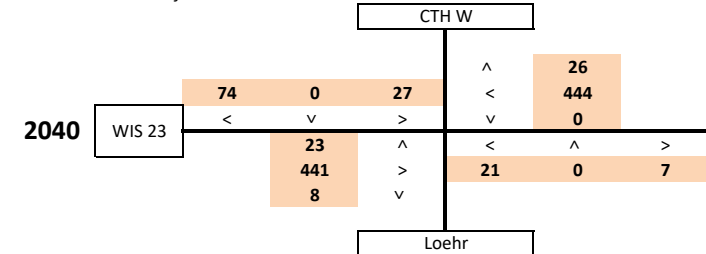

A-63

WIS 23/CTH W - J-Turn Volume development (4-Lane On-Alignment and Hybrid)

April 9, 2018

PM PEAK HOUR

4-lane On-Alignment Alternative Volumes (2040)

Intersection volumes from WisDOT forecast (4-6-2018)

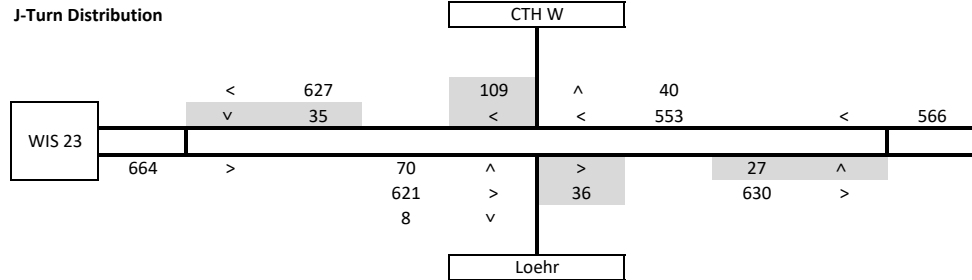
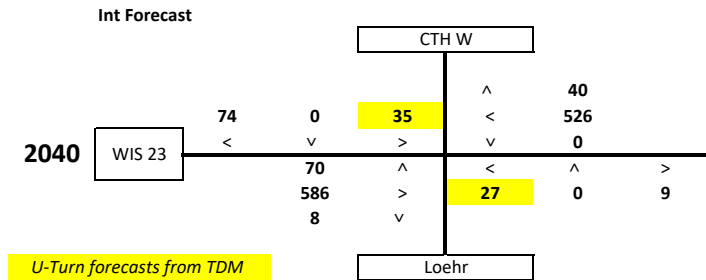

U-Turn Heavy Truck% 14.3%
 Critical Headway 4.69 s
 Follow Up Headway 2.74 s
 CTH W to west U-Turn 1,300 ft
 WB U-Turn storage 450 ft

U-Turn Heavy Truck% 17.2%
 Critical Headway 4.74 s
 Follow Up Headway 2.77 s
 Loehr Rd to east U-Turn 1,150 ft
 EB U-Turn storage 450 ft

Note: EB to WB U-turn includes CTH W/Hinn NBL & NBT in truck % calc.

Hybrid Alternative Factored Volumes (2040)

Intersection volumes factored down based on WIS 23 mainline trends

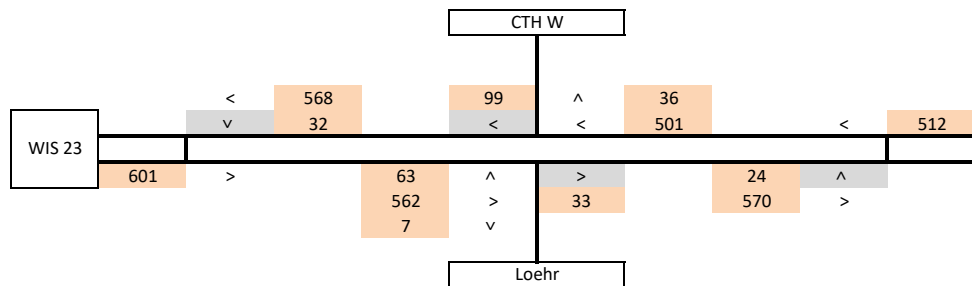
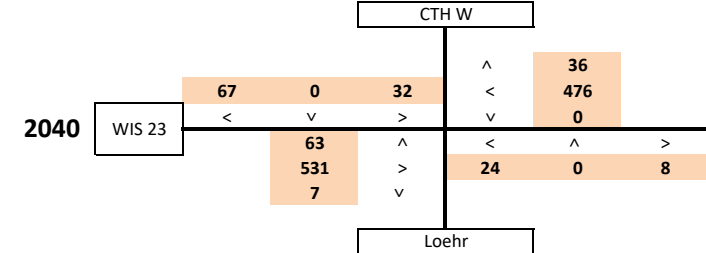

A-64

WIS 23/CTH UU Interchange Volumes: 4-Lane On-Alignment and Hybrid Alternatives
 April 9, 2018

Location		2040 AADT		Factor
		4-Lane	Hybrid	
Site 200219	West of CTH UU	16,700	15,600	93.4%
Site 201147	East of CTH UU	11,900	11,000	92.4%
		Average		92.9%

2040 4-Lane On-Alignment: AM Peak
 Intersection volumes from WisDOT forecast (4-6-2018)

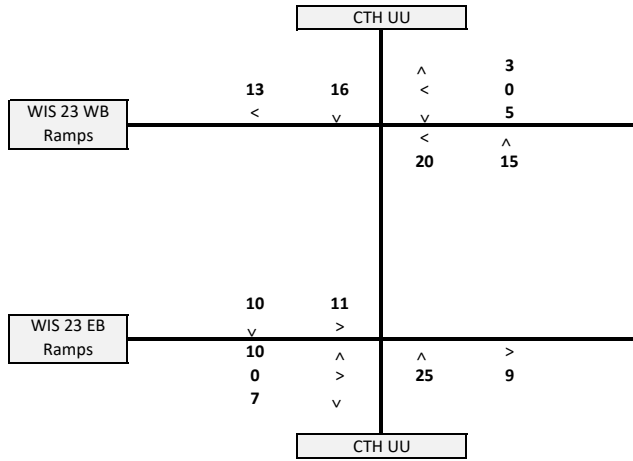

2040 Hybrid: AM Peak
 Int volumes factored down based on WIS 23 mainline trends

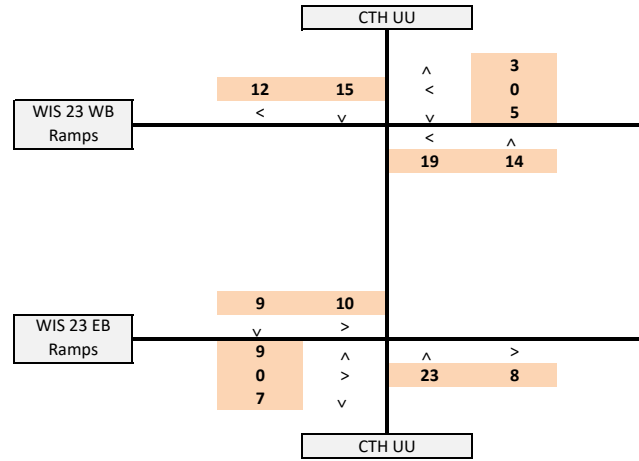

2040 4-Lane On-Alignment: PM Peak
 Intersection volumes from WisDOT forecast (4-6-2018)

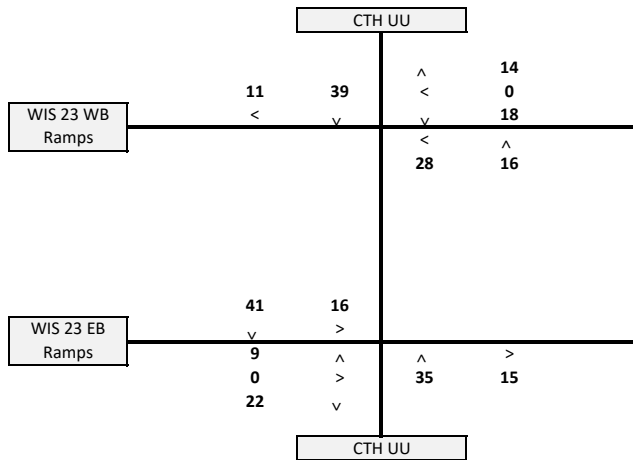

2040 Hybrid: PM Peak
 Int volumes factored down based on WIS 23 mainline trends

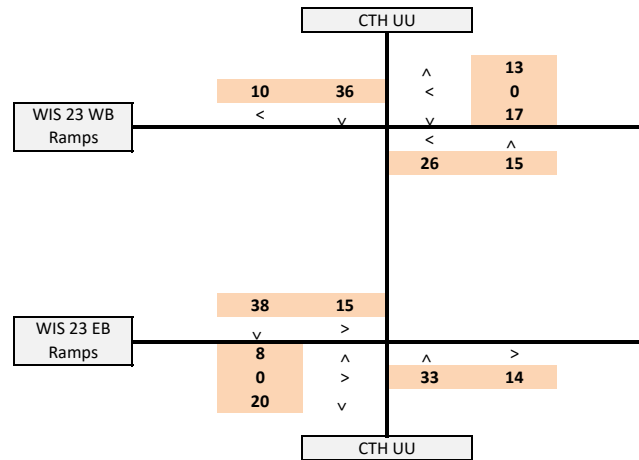

A-65

WIS 23/CTH G Interchange Volumes: 4-Lane On-Alignment and Hybrid Alternatives
 April 9, 2018

Location		2040 AADT		Factor
		4-Lane	Hybrid	
Site 201153	West of CTH G	9,900	8,800	88.9%
Site 590118	East of CTH G	9,500	7,900	83.2%
Average				86.0%

2040 4-Lane On-Alignment: AM Peak
 Intersection volumes from WisDOT forecast (4-6-2018)

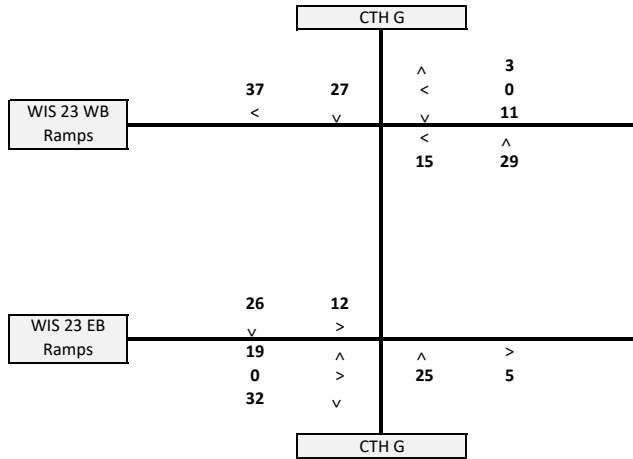

2040 4-Lane On-Alignment: PM Peak
 Intersection volumes from WisDOT forecast (4-6-2018)

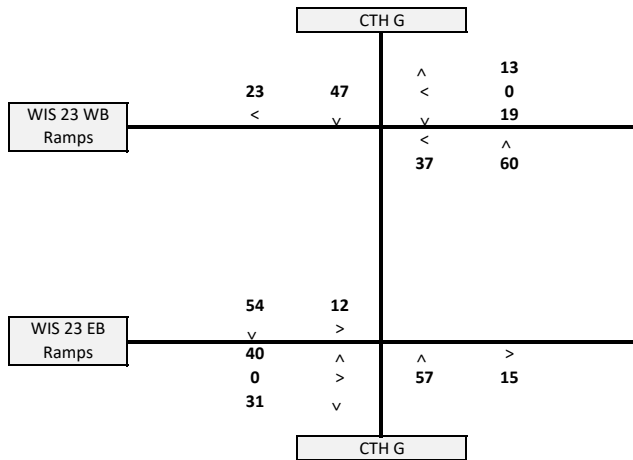

2040 Hybrid: AM Peak
 Int volumes factored down based on WIS 23 mainline trends

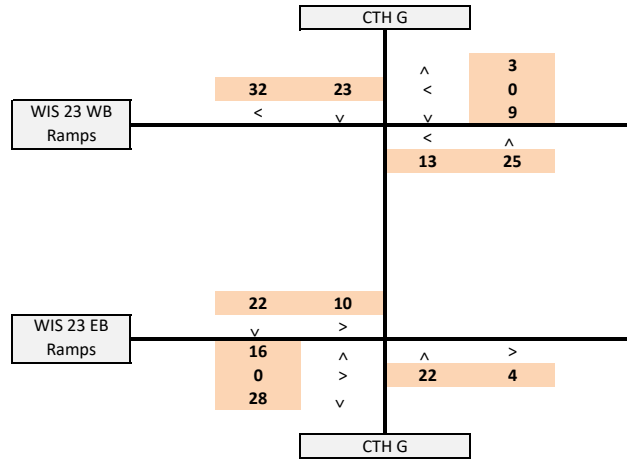

2040 Hybrid: PM Peak
 Int volumes factored down based on WIS 23 mainline trends

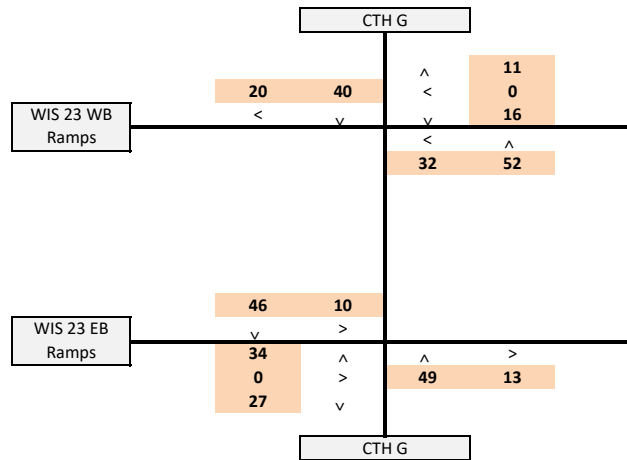

A-66

WisDot Bureau of Planning
 Traffic Forecasting Section
 Forecast by: Chris Chritton
 Phone: 608-266-0194
 Email: chris.chritton@dot.wi.gov

Projected AM Design Hour Traffic Volumes

 Indicates roundabout

Design Hour: 7:00-8:00am

Forecast Completed: 4/6/2018

Project Description

Project ID(s): 1440-13-00 (15-00) (No-Build)
 Route(s): STH 23
 Region/COUNTY(IES): NE / Fond du Lac - Sheboygan
 Location: @ CTH UU

Design Hour Turning Movement Data

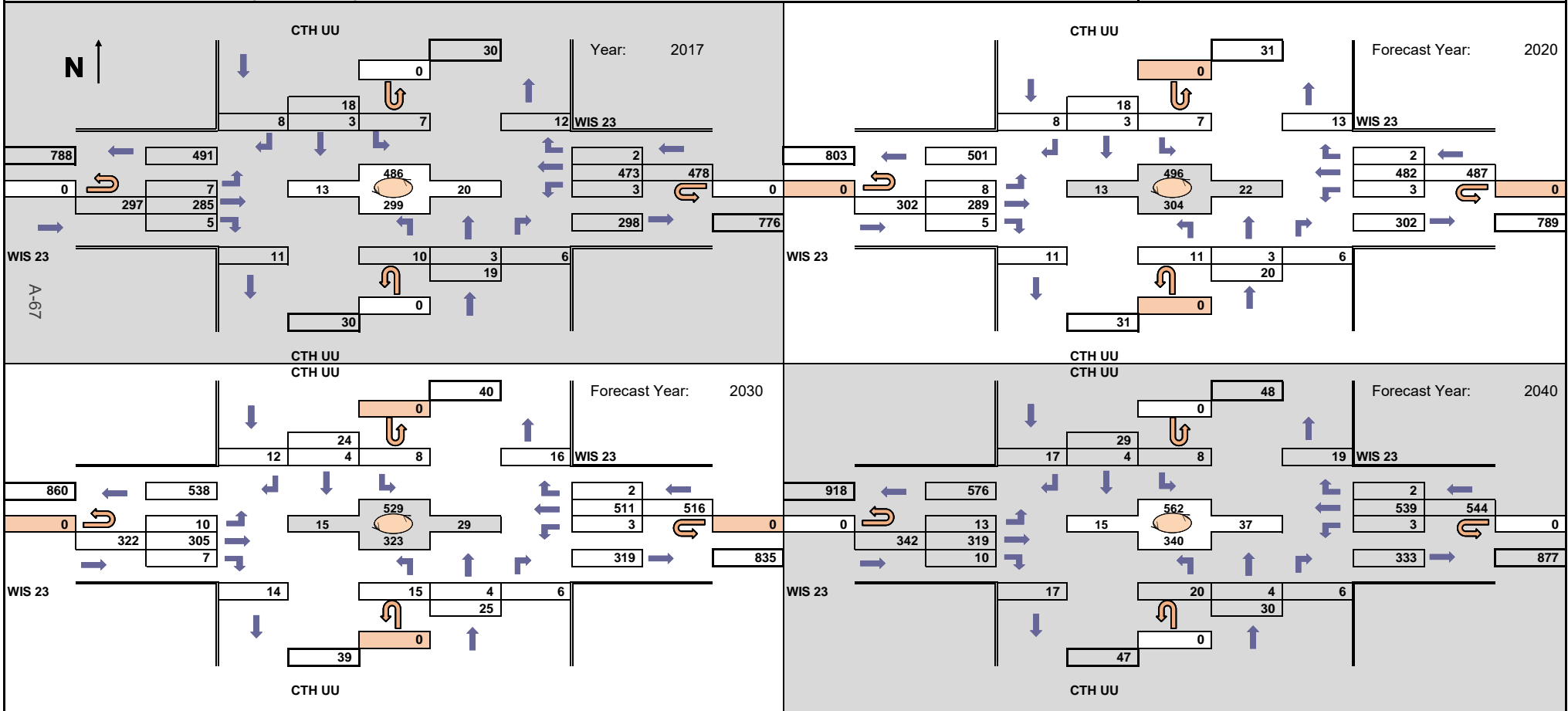

WisDot Bureau of Planning
 Traffic Forecasting Section
 Forecast by: Chris Chritton
 Phone: 608-266-0194
 Email: chris.chritton@dot.wi.gov

Projected PM Design Hour Traffic Volumes

 Indicates roundabout

Design Hour: 4:00-5:00pm

Forecast Completed: 4/6/2018

Project Description

Project ID(s): 1440-13-00 (15-00) (No-Build)
 Route(s): STH 23
 Region/COUNTY(IES): NE / Fond du Lac - Sheboygan
 Location: @ CTH UU

Design Hour Turning Movement Data

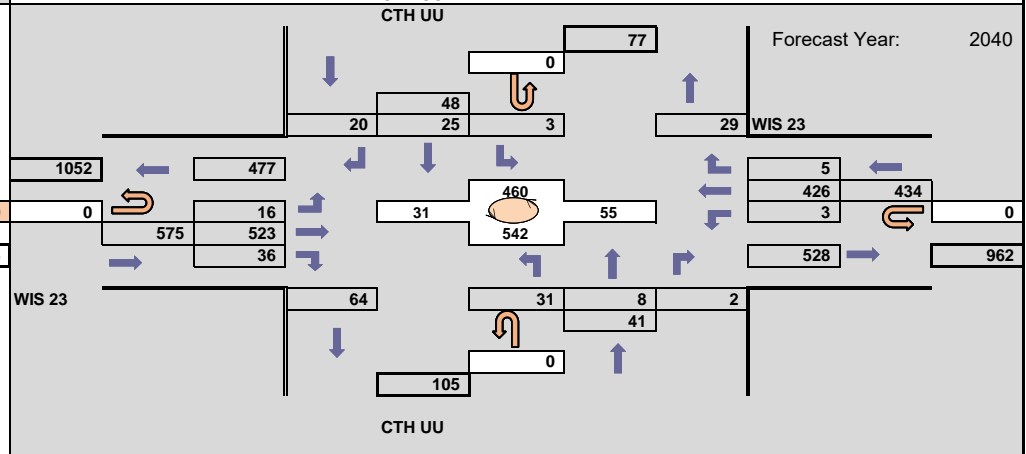
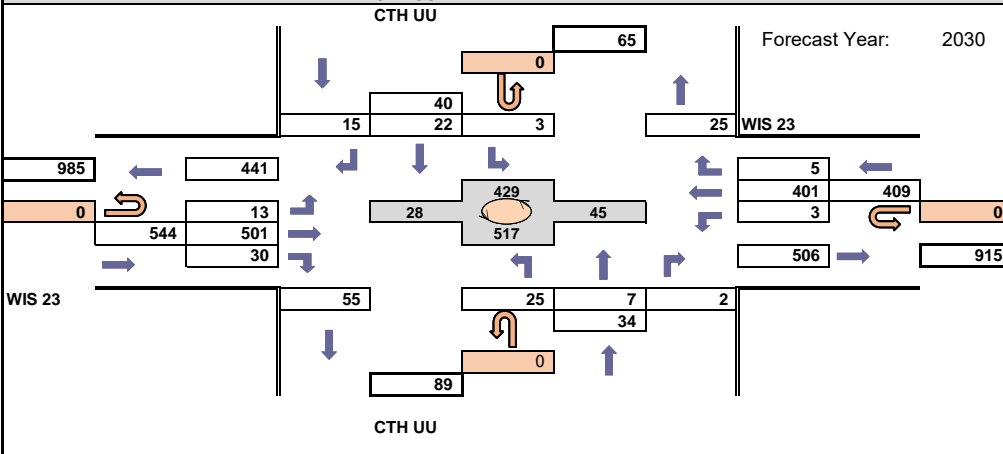
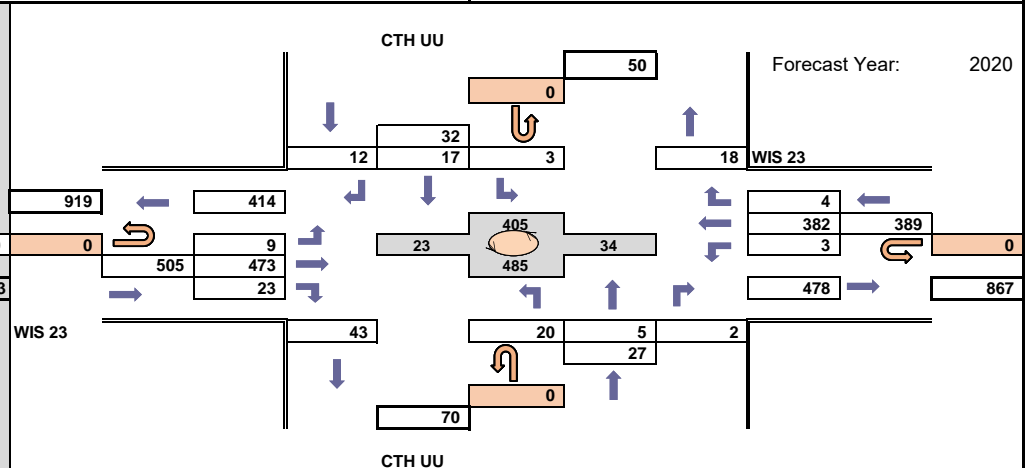
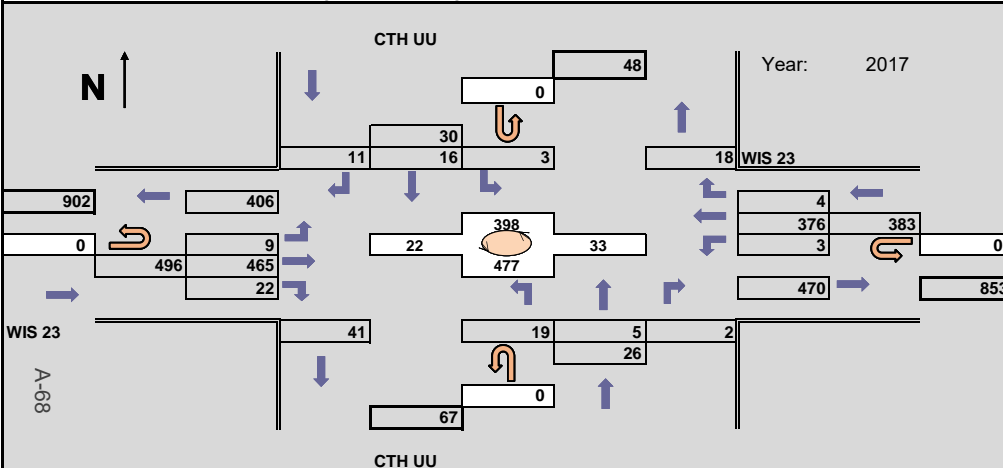

WisDot Bureau of Planning
 Traffic Forecasting Section
 Forecast by: Chris Chritton
 Phone: 608-266-0194
 Email: chris.chritton@dot.wi.gov

Projected AM Design Hour Traffic Volumes

 Indicates roundabout

Design Hour: 6:45-7:45am

Forecast Completed: 4/6/2018

Project Description

Project ID(s): 1440-13-00 (15-00) (No-Build)
 Route(s): STH 23
 Region/COUNTY(IES): NE / Fond du Lac - Sheboygan
 Location: @ CTH W - Loehr

Design Hour Turning Movement Data

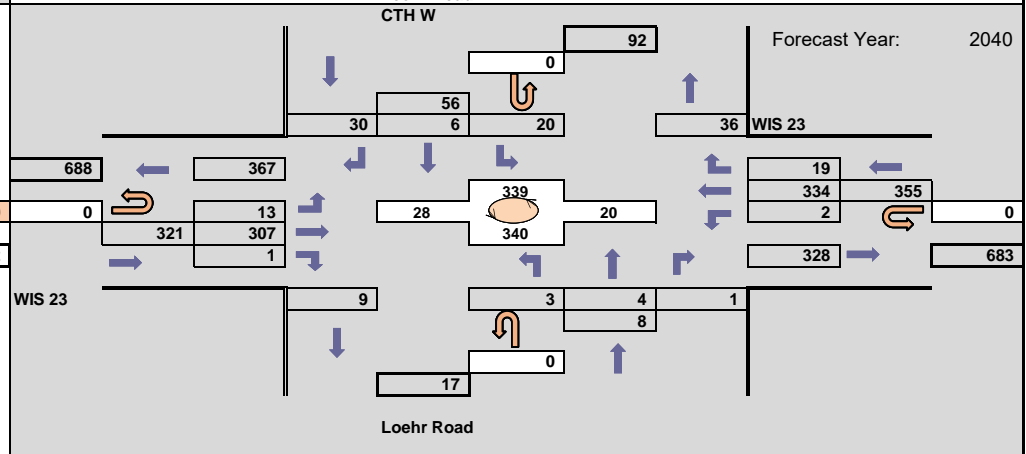
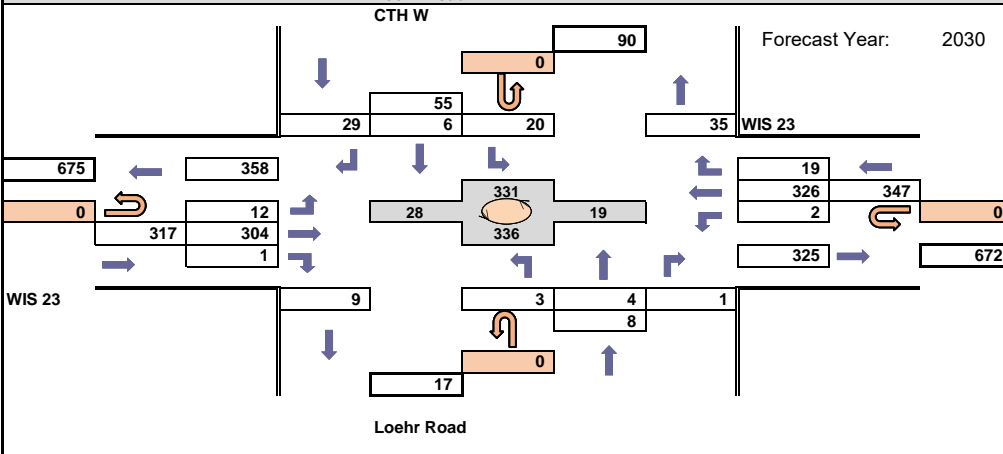
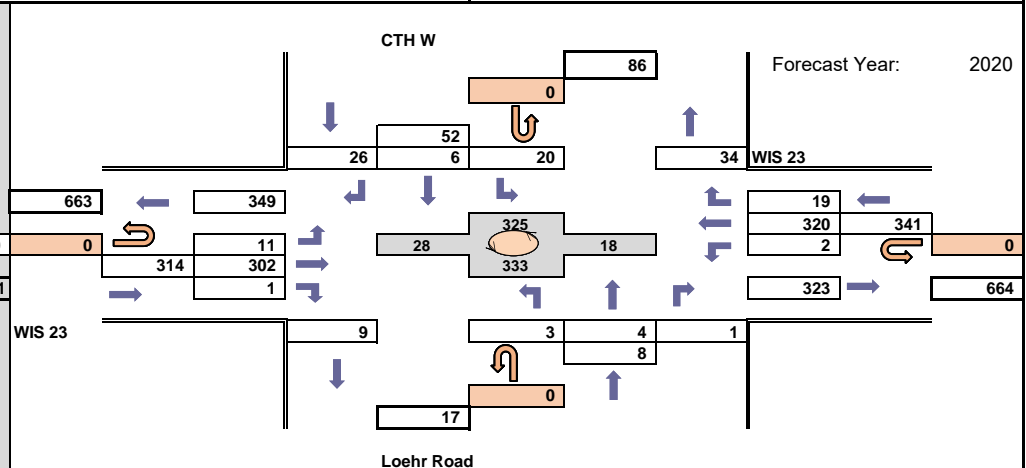
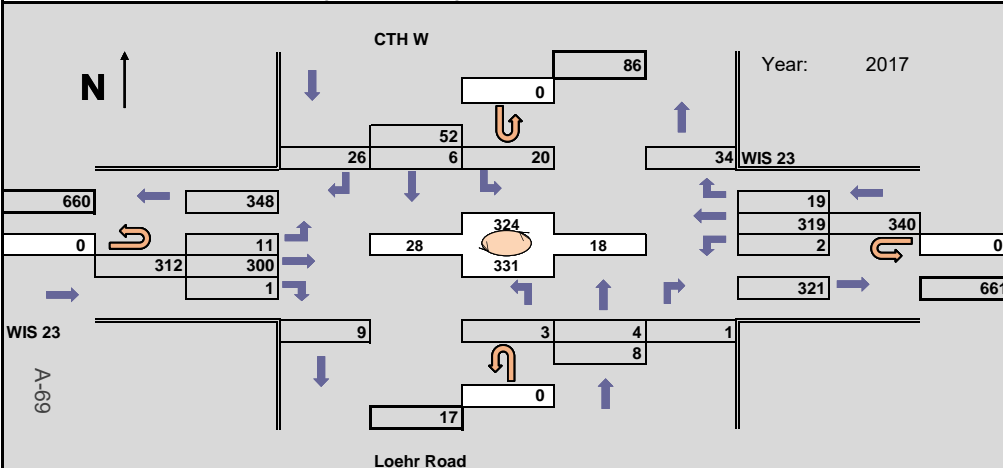

WisDot Bureau of Planning
 Traffic Forecasting Section
 Forecast by: Chris Chritton
 Phone: 608-266-0194
 Email: chris.chritton@dot.wi.gov

Projected PM Design Hour Traffic Volumes

 Indicates roundabout

Design Hour: 4:15-5:15pm

Forecast Completed: 4/6/2018

Project Description

Project ID(s): 1440-13-00 (15-00) (No-Build)
 Route(s): STH 23
 Region/COUNTY(IES): NE / Fond du Lac - Sheboygan
 Location: @ CTH W - Loehr

Design Hour Turning Movement Data

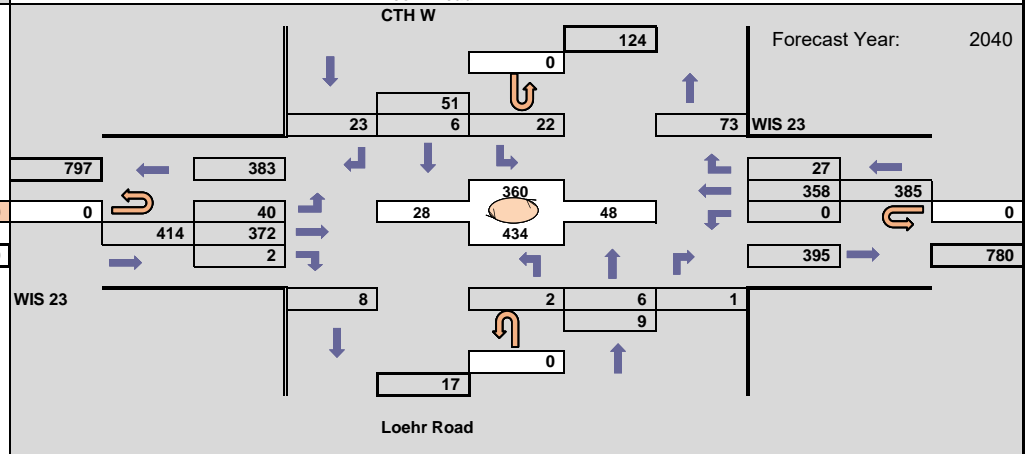
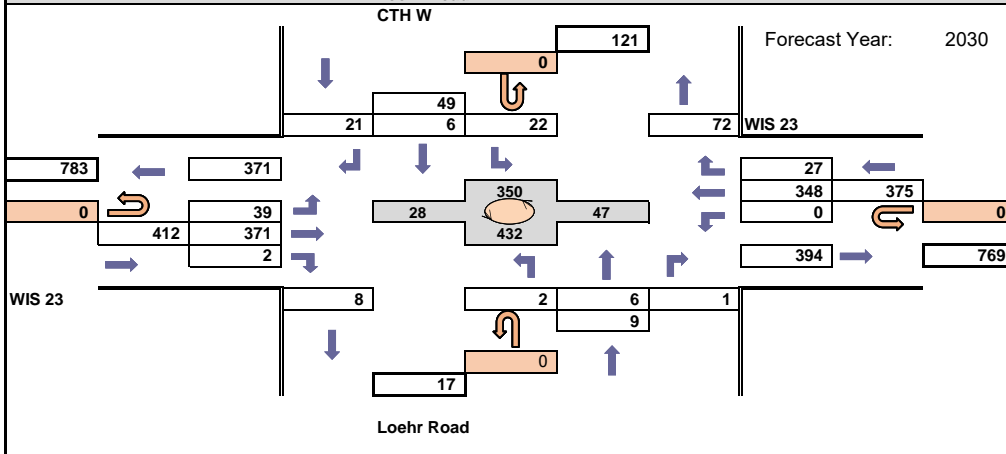
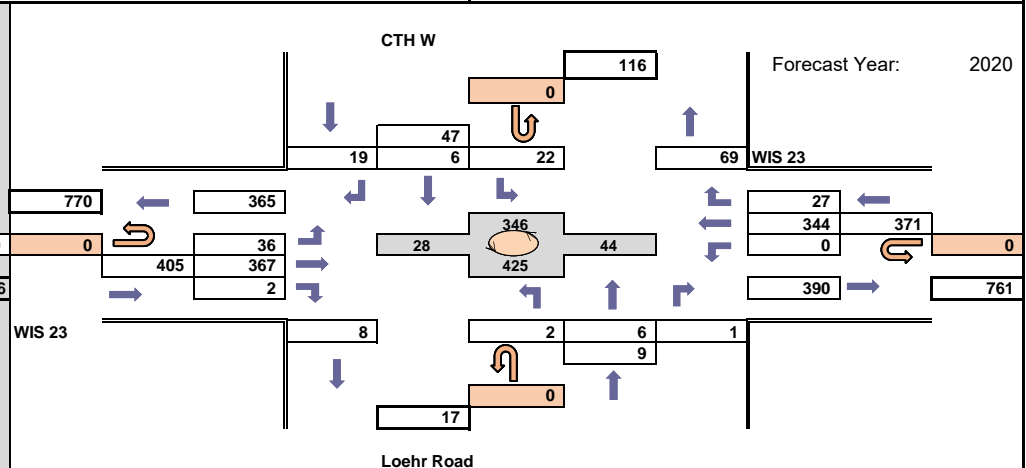
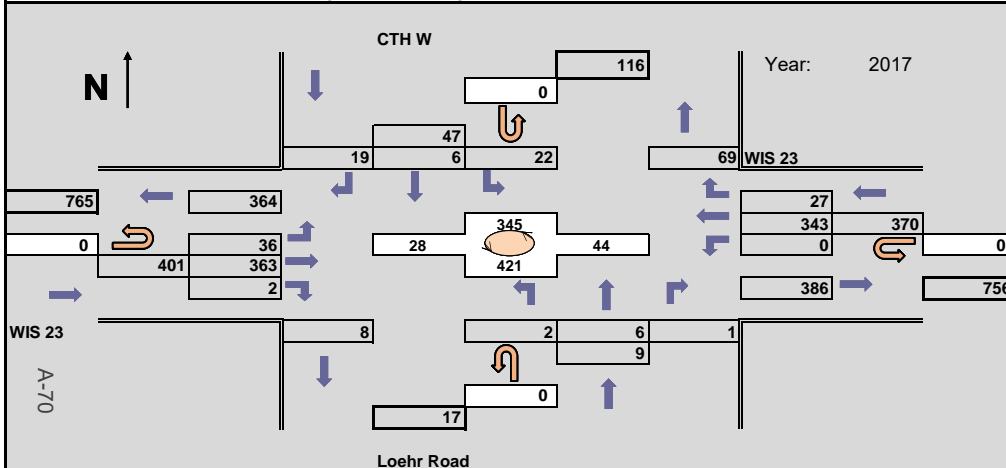

WisDot Bureau of Planning
 Traffic Forecasting Section
 Forecast by: Chris Chritton
 Phone: 608-266-0194
 Email: chris.chritton@dot.wi.gov

Projected AM Design Hour Traffic Volumes

 Indicates roundabout

Design Hour: 6:45-7:45am

Forecast Completed: 4/6/2018

Project Description
 Project ID(s): 1440-13-00 (15-00) (No-Build)
 Route(s): STH 23
 Region/COUNTY(IES): NE / Fond du Lac - Sheboygan
 Location: @ CTH G

Design Hour Turning Movement Data

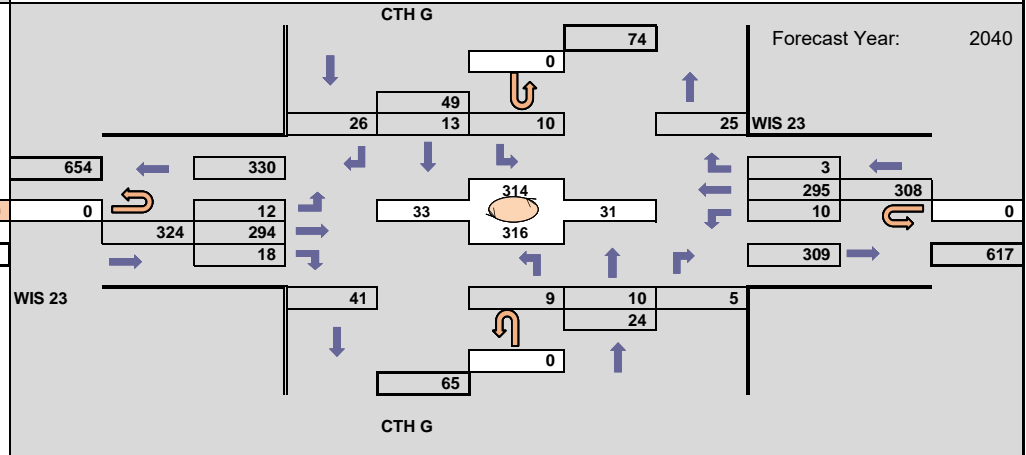
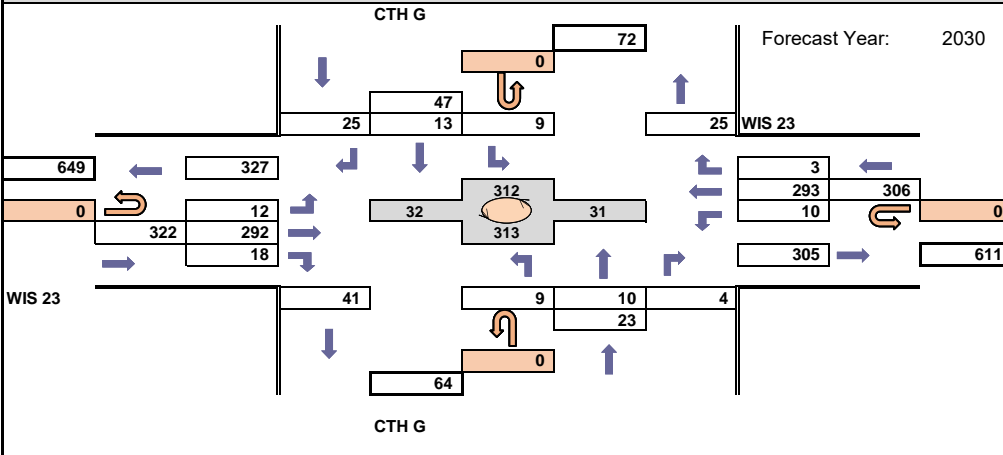
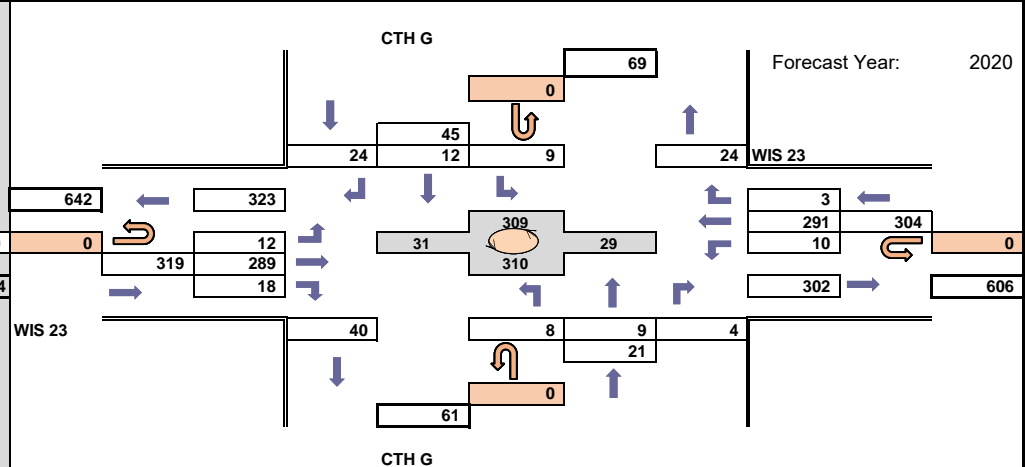
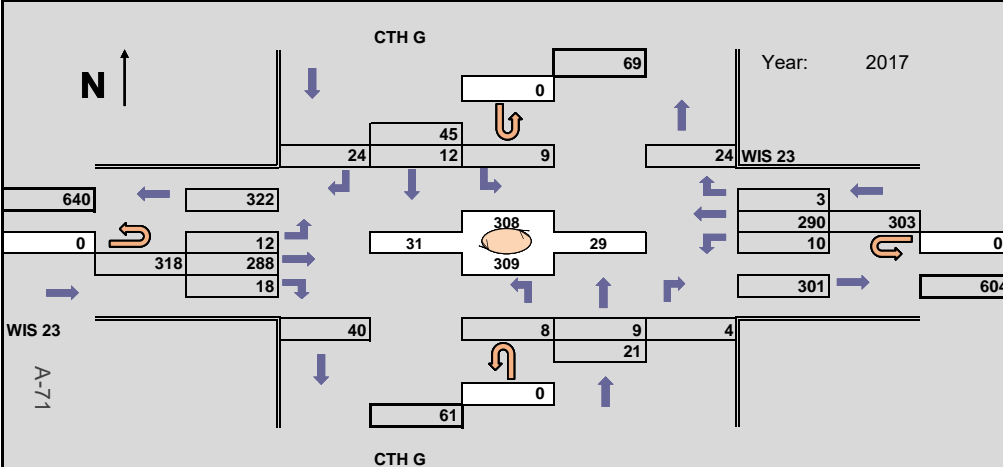

WisDot Bureau of Planning
 Traffic Forecasting Section
 Forecast by: Chris Chritton
 Phone: 608-266-0194
 Email: chris.chritton@dot.wi.gov

Projected PM Design Hour Traffic Volumes

 Indicates roundabout

Design Hour: 4:15-5:15pm

Forecast Completed: 4/6/2018

Project Description
 Project ID(s): 1440-13-00 (15-00) (No-Build)
 Route(s): STH 23
 Region/COUNTY(IES): NE / Fond du Lac - Sheboygan
 Location: @ CTH G

Design Hour Turning Movement Data

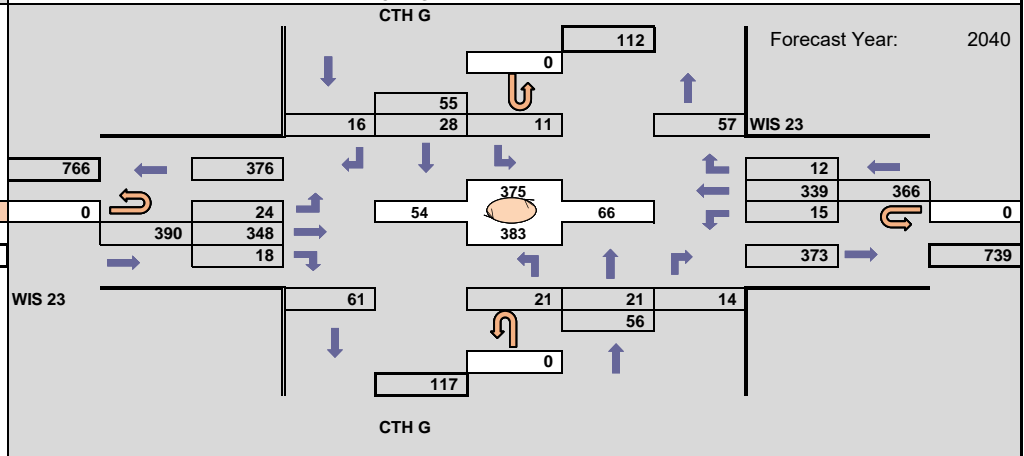
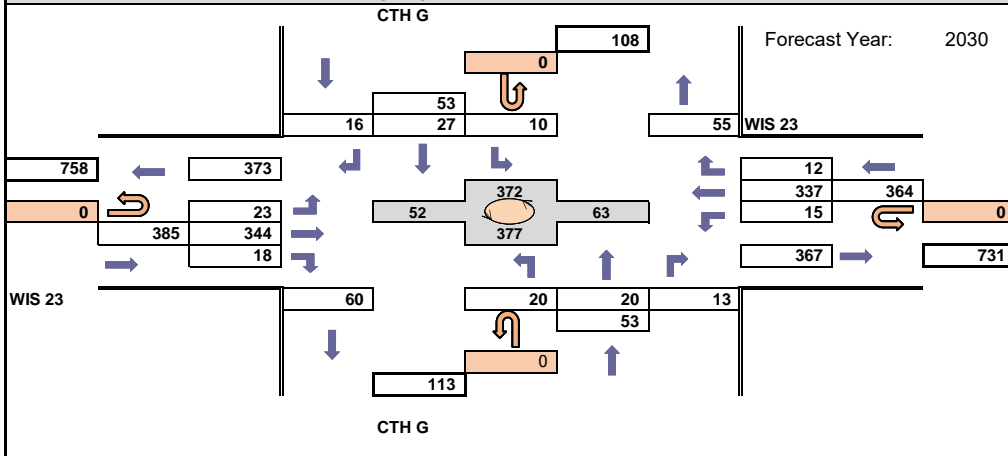
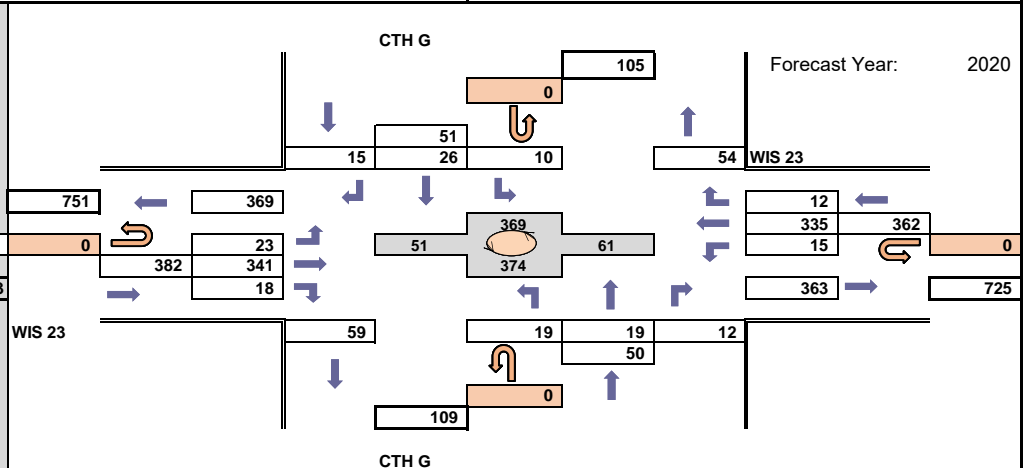
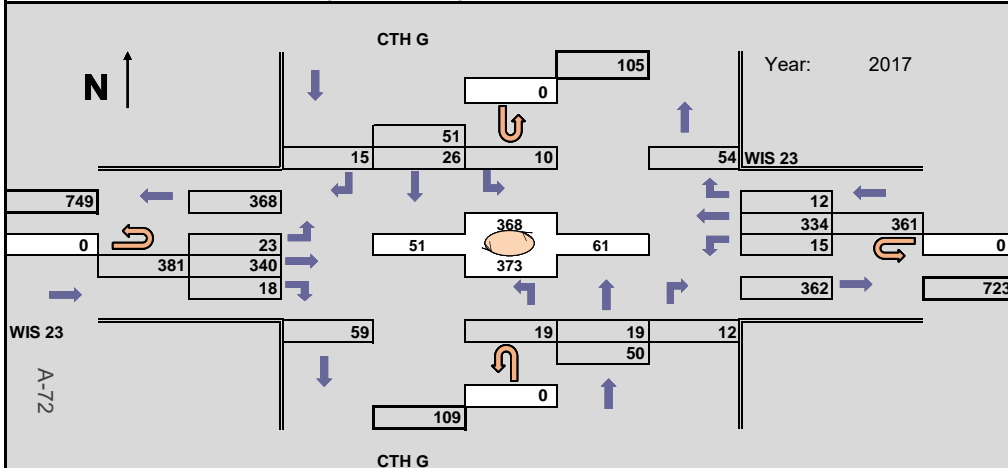

WisDot Bureau of Planning
 Traffic Forecasting Section
 Forecast by: Chris Chritton
 Phone: 608-266-0194
 Email: chris.chritton@dot.wi.gov

Projected AM Design Hour Traffic Volumes

 Indicates roundabout

Design Hour: 7:00-8:00am

Forecast Completed: 4/6/2018

Project Description

Project ID(s): 1440-13-00 (15-00) (4-Lane Build)
 Route(s): STH 23
 Region/COUNTY(IES): NE / Fond du Lac - Sheboygan
 Location: @ CTH UU - North Roundabout

Design Hour Turning Movement Data

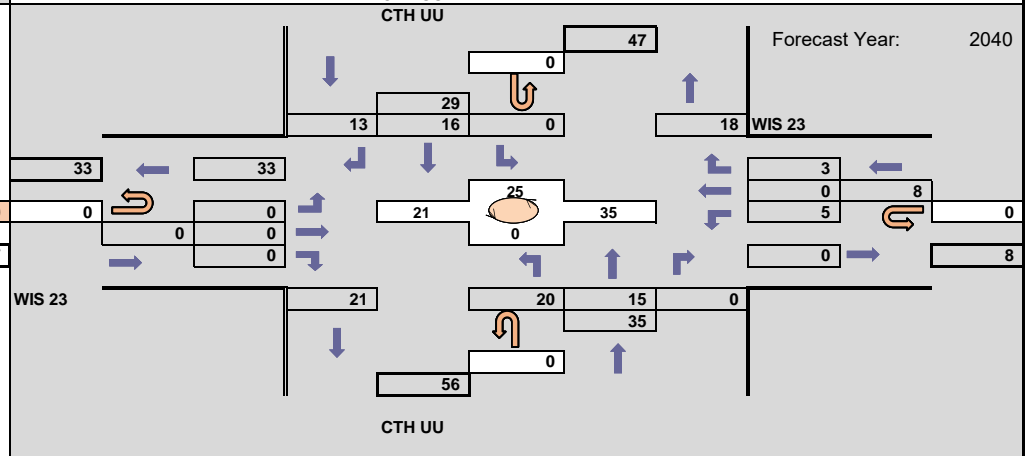
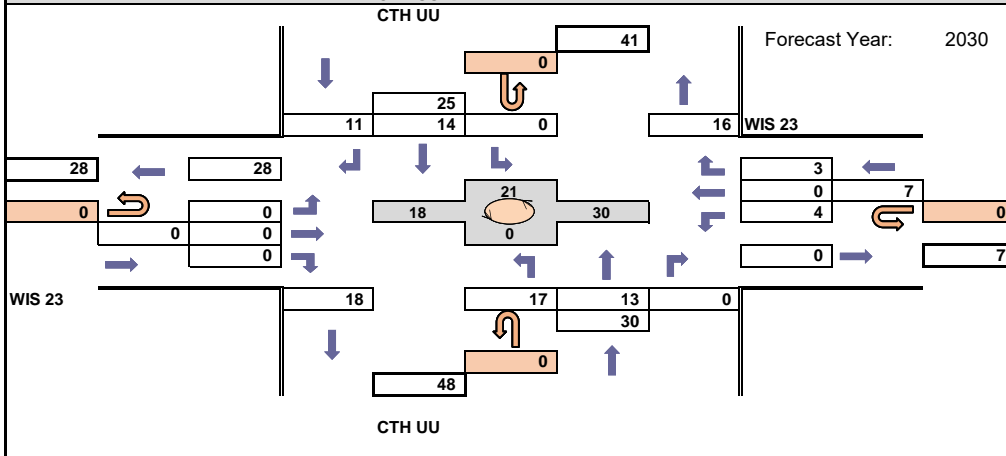
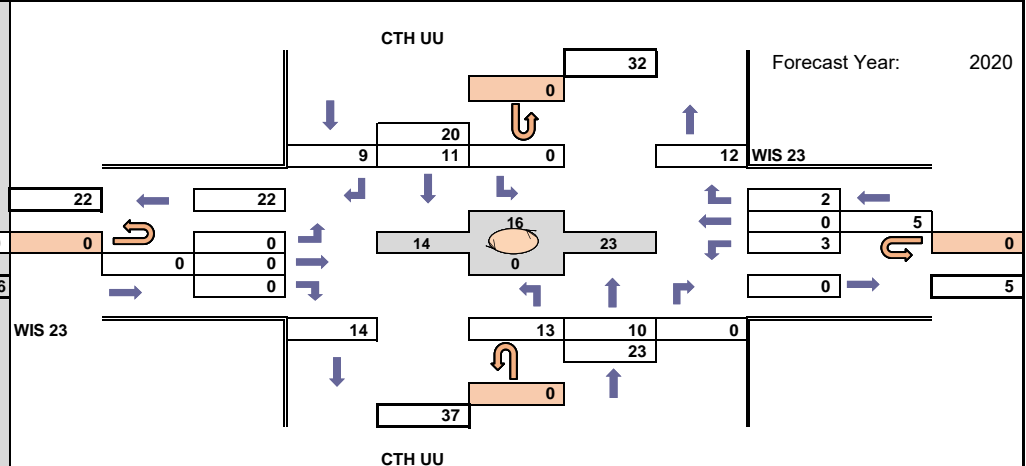
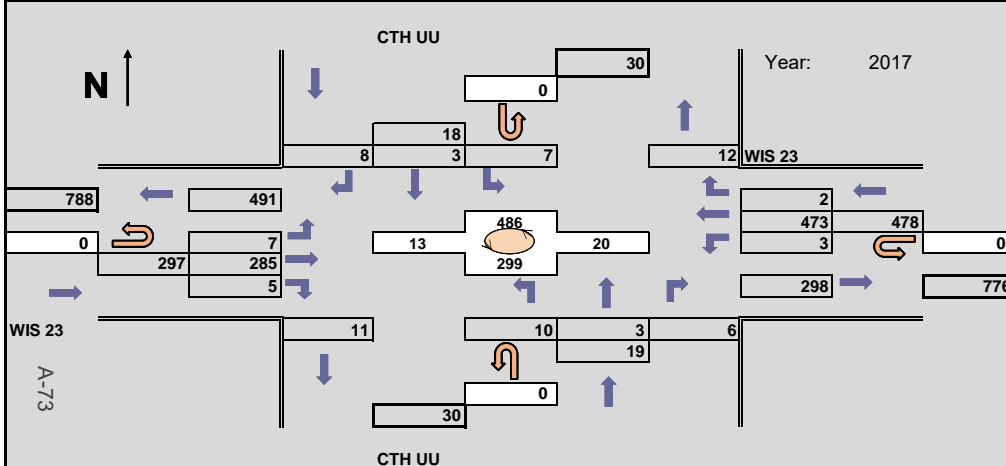

WisDot Bureau of Planning
 Traffic Forecasting Section
 Forecast by: Chris Chritton
 Phone: 608-266-0194
 Email: chris.chritton@dot.wi.gov

Projected PM Design Hour Traffic Volumes

 Indicates roundabout

Design Hour: 4:00-5:00pm

Forecast Completed: 4/6/2018

Project Description
 Project ID(s): 1440-13-00 (15-00) (4-Lane Build)
 Route(s): STH 23
 Region/COUNTY(IES): NE / Fond du Lac - Sheboygan
 Location: @ CTH UU - North Roundabout

Design Hour Turning Movement Data

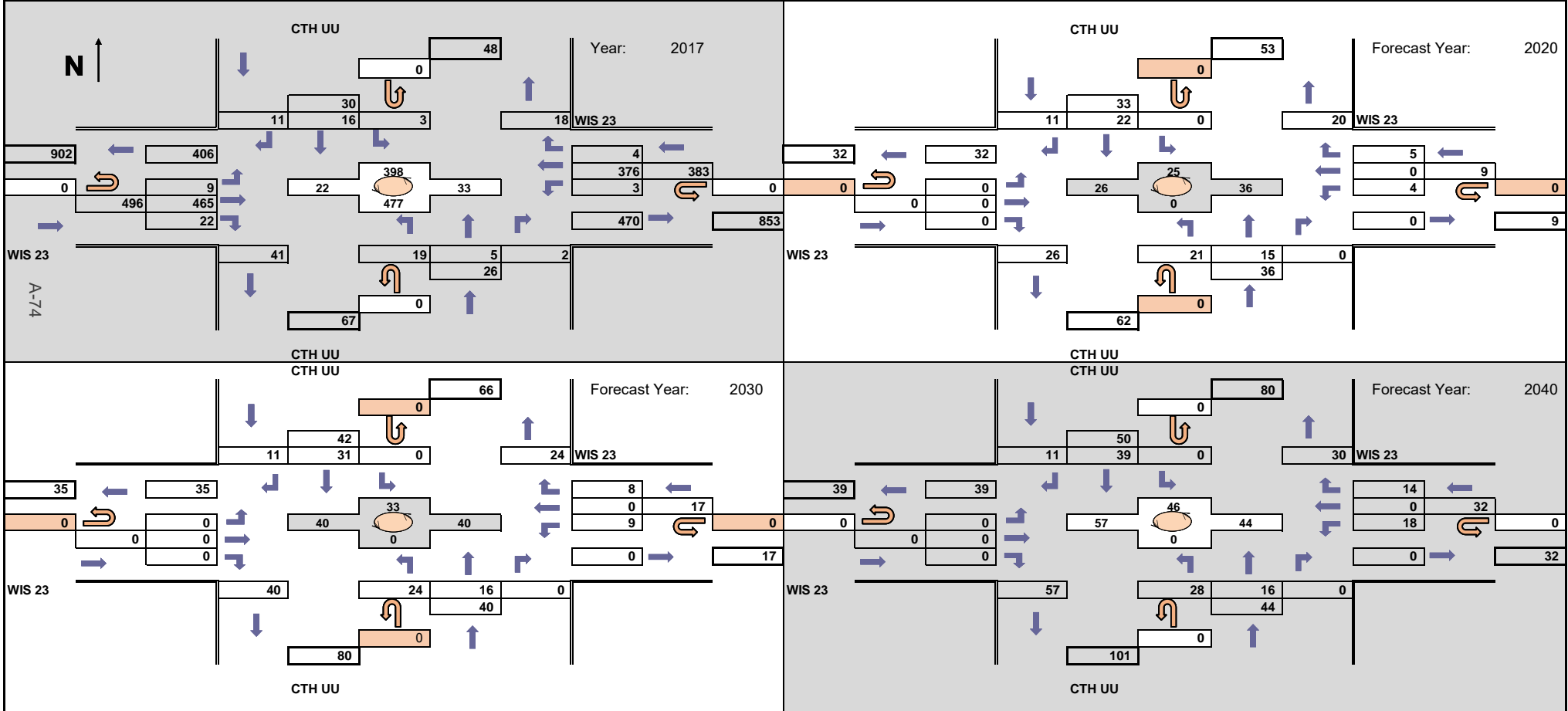

WisDot Bureau of Planning
 Traffic Forecasting Section
 Forecast by: Chris Chritton
 Phone: 608-266-0194
 Email: chris.chritton@dot.wi.gov

Projected AM Design Hour Traffic Volumes

 Indicates roundabout

Design Hour: 7:00-8:00am

Forecast Completed: 4/6/2018

Project Description

Project ID(s): 1440-13-00 (15-00) (4-Lane Build)
 Route(s): STH 23
 Region/COUNTY(IES): NE / Fond du Lac - Sheboygan
 Location: @ CTH UU - South Roundabout

Design Hour Turning Movement Data

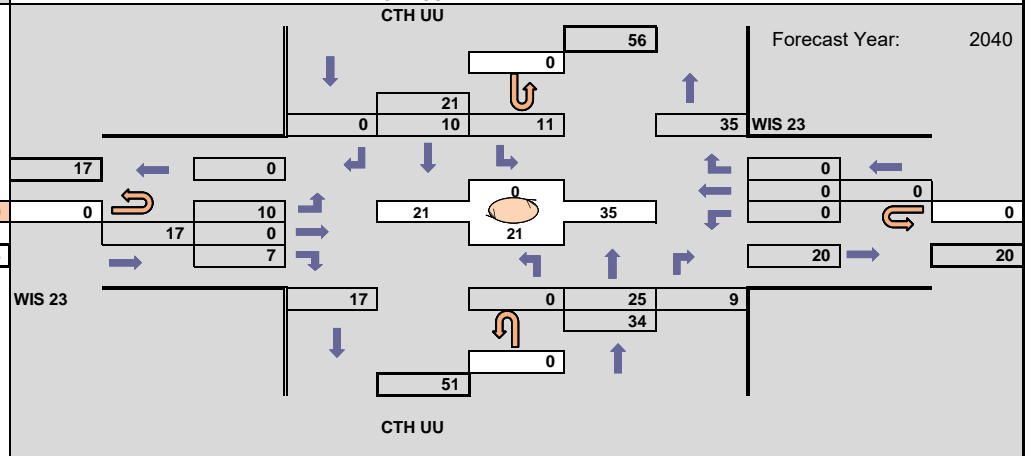
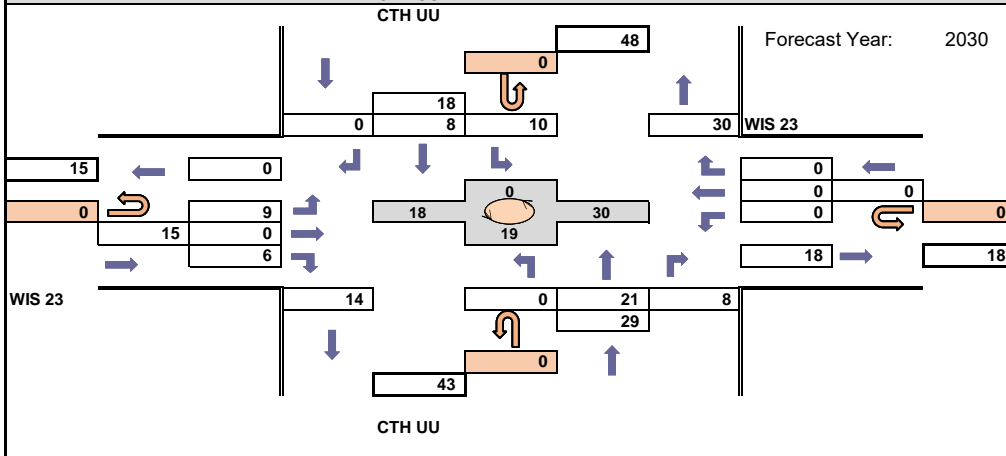
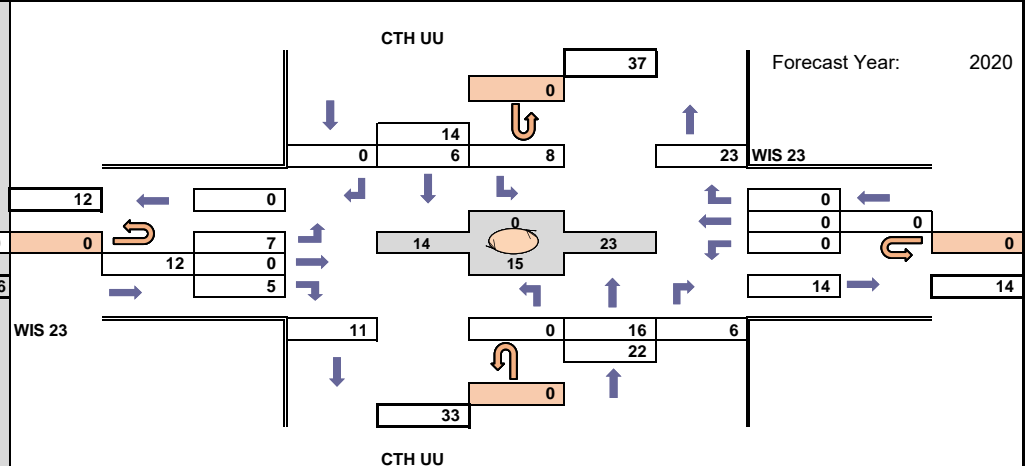
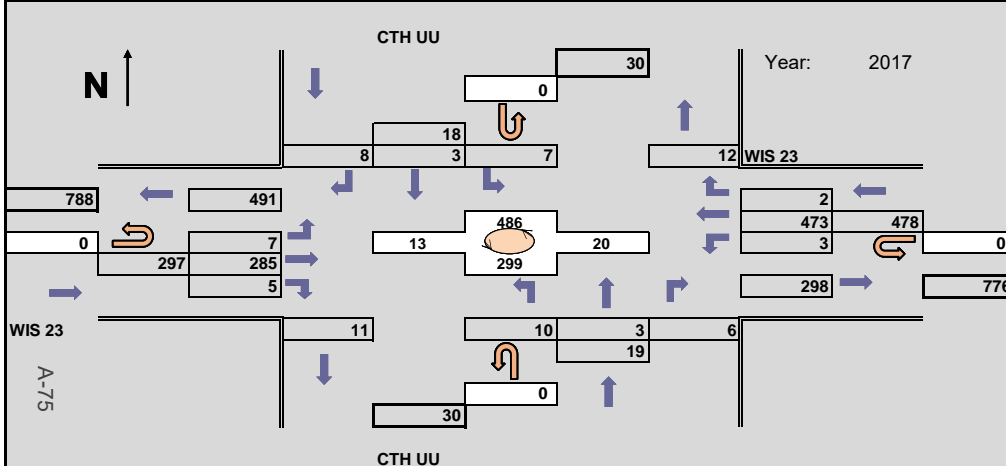

WisDot Bureau of Planning
 Traffic Forecasting Section
 Forecast by: Chris Chritton
 Phone: 608-266-0194
 Email: chris.chritton@dot.wi.gov

Projected PM Design Hour Traffic Volumes

 Indicates roundabout

Design Hour: 4:00-5:00pm

Forecast Completed: 4/6/2018

Project Description

Project ID(s): 1440-13-00 (15-00) (4-Lane Build)
 Route(s): STH 23
 Region/COUNTY(IES): NE / Fond du Lac - Sheboygan
 Location: @ CTH UU - South Roundabout

Design Hour Turning Movement Data

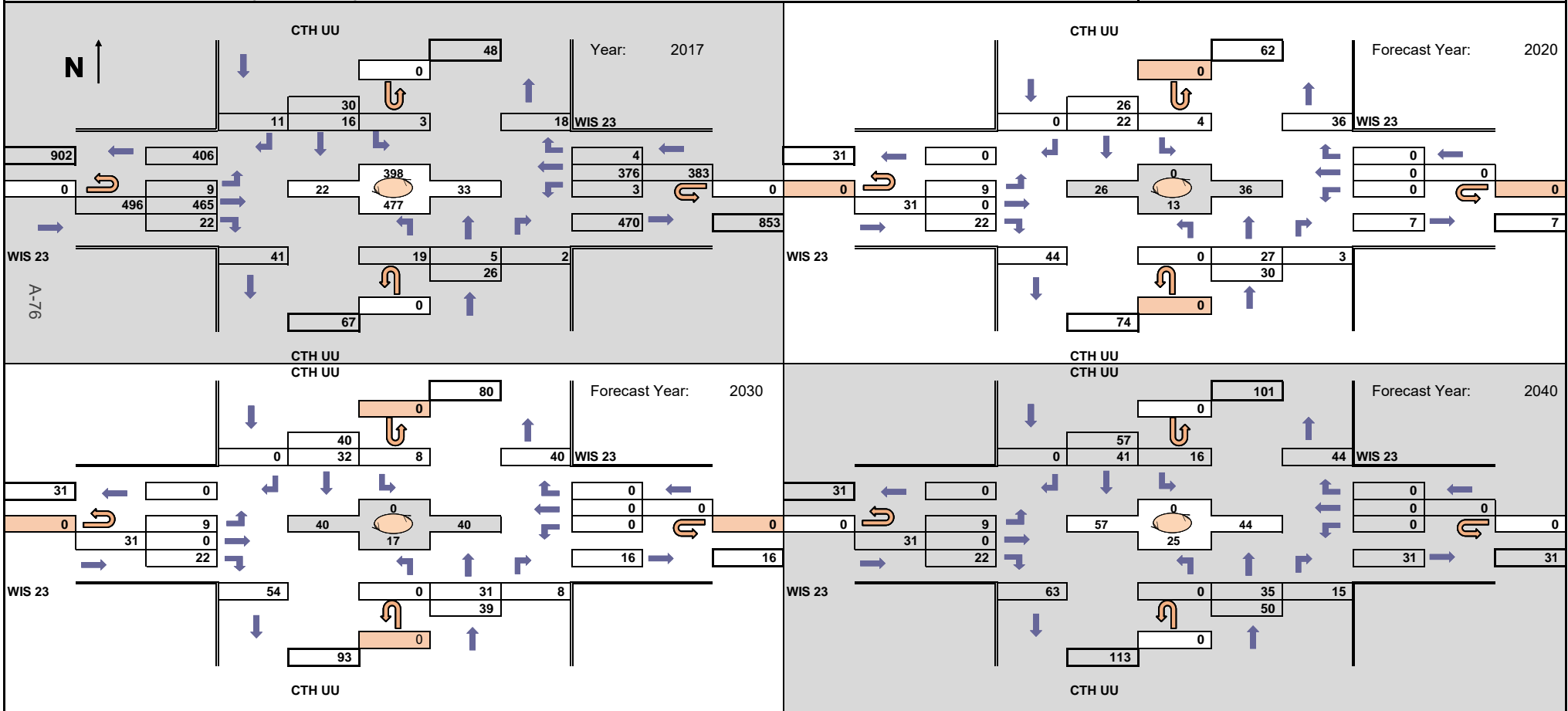

WisDot Bureau of Planning
 Traffic Forecasting Section
 Forecast by: Chris Chritton
 Phone: 608-266-0194
 Email: chris.chritton@dot.wi.gov

Projected AM Design Hour Traffic Volumes

 Indicates roundabout

Design Hour: 6:45-7:45am

Forecast Completed: 4/6/2018

Project Description

Project ID(s): 1440-13-00 (15-00) (4-Lane Build)
 Route(s): STH 23
 Region/COUNTY(IES): NE / Fond du Lac - Sheboygan
 Location: @ Hinn - CTH W South

Design Hour Turning Movement Data

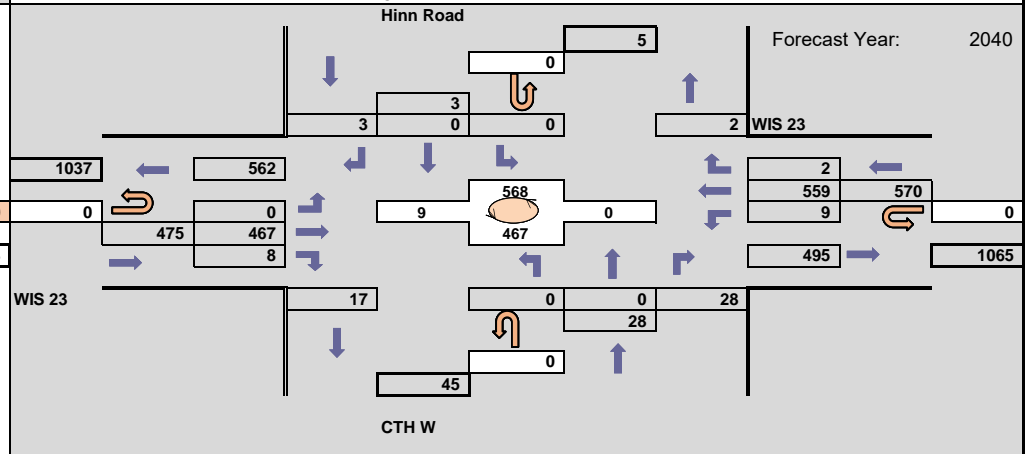
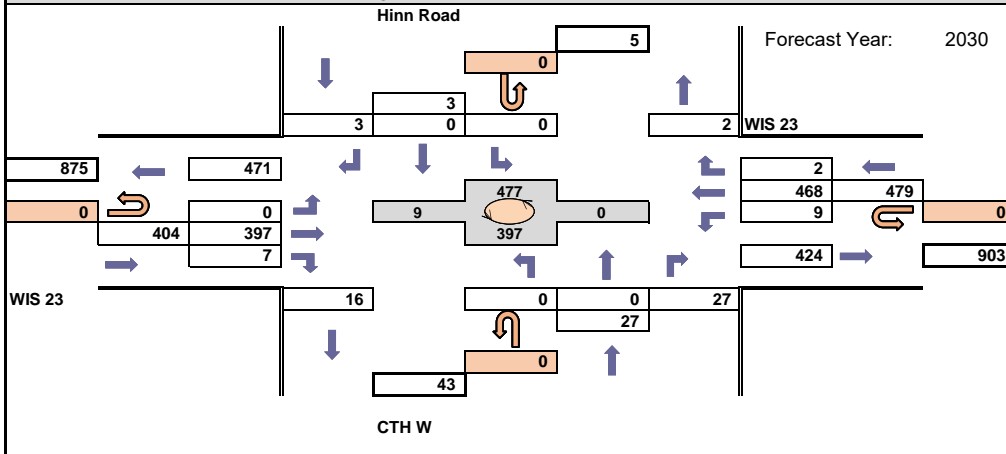
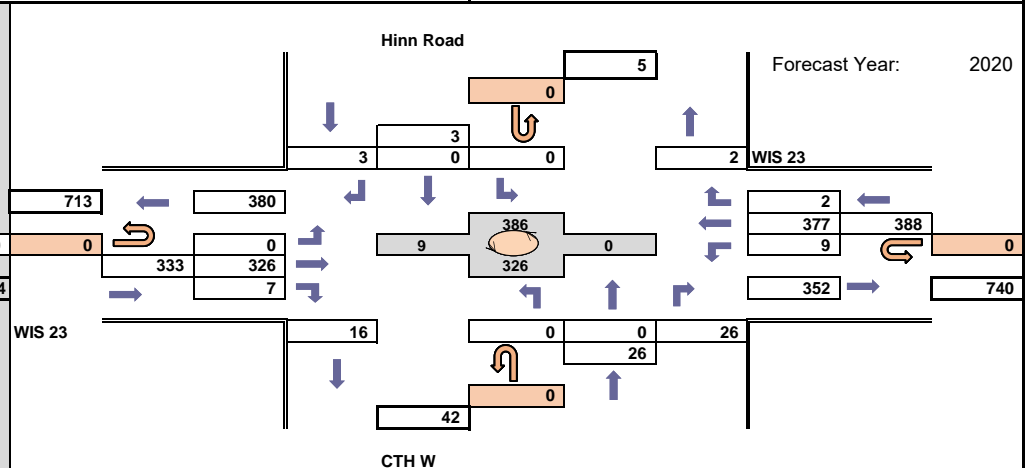
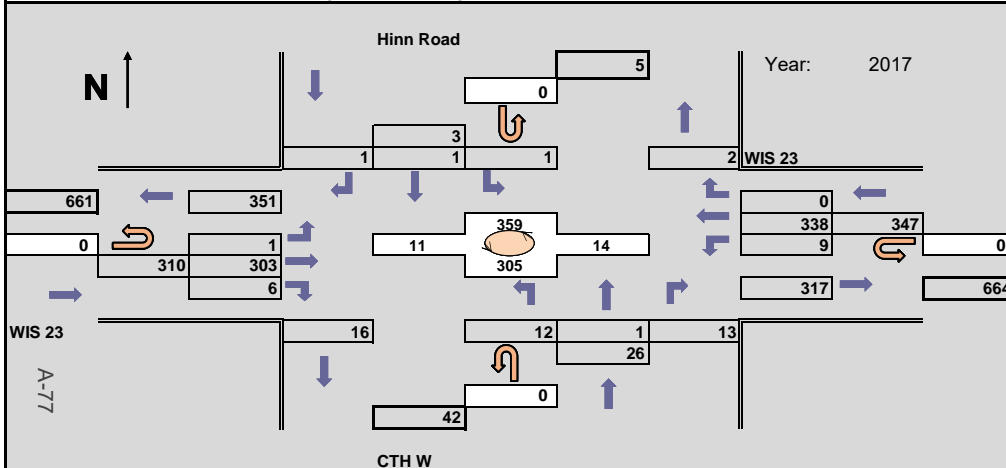

WisDot Bureau of Planning
 Traffic Forecasting Section
 Forecast by: Chris Chritton
 Phone: 608-266-0194
 Email: chris.chritton@dot.wi.gov

Projected PM Design Hour Traffic Volumes

 Indicates roundabout

Design Hour: 4:15-5:15pm

Forecast Completed: 4/6/2018

Project Description

Project ID(s): 1440-13-00 (15-00) (4-Lane Build)
 Route(s): STH 23
 Region/COUNTY(IES): NE / Fond du Lac - Sheboygan
 Location: @ Hinn - CTH W South

Design Hour Turning Movement Data

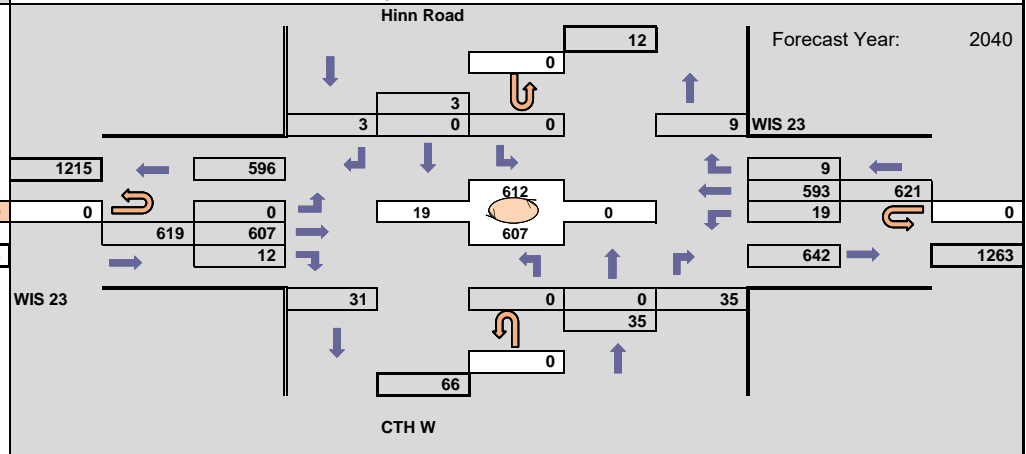
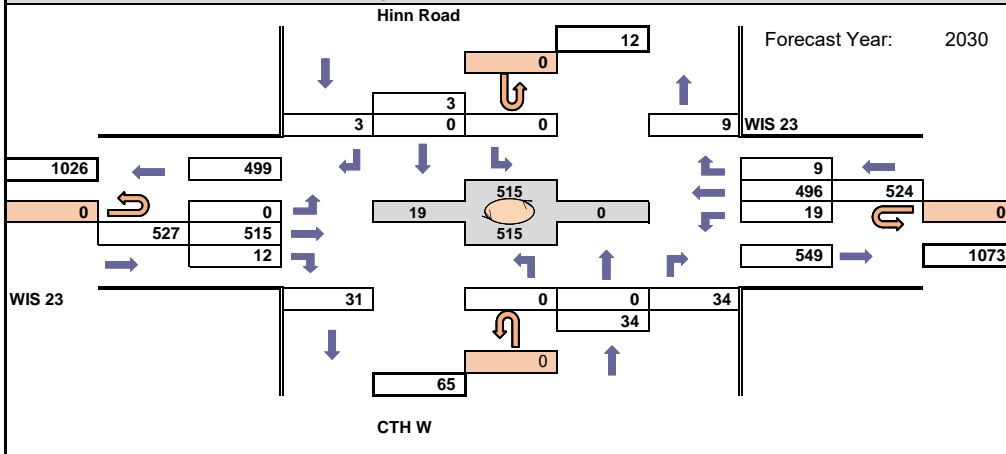
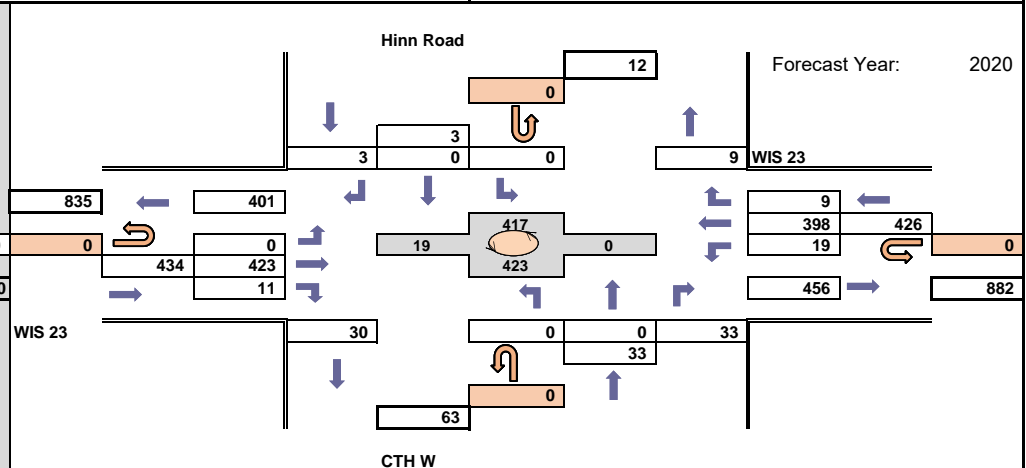
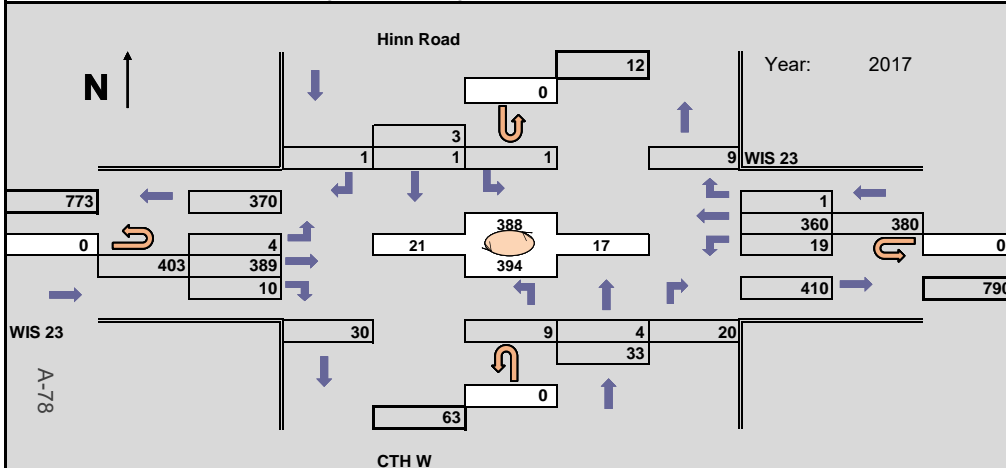

WisDot Bureau of Planning
 Traffic Forecasting Section
 Forecast by: Chris Chritton
 Phone: 608-266-0194
 Email: chris.chritton@dot.wi.gov

Projected AM Design Hour Traffic Volumes

 Indicates roundabout

Design Hour: 6:45-7:45am

Forecast Completed: 4/6/2018

Project Description

Project ID(s): 1440-13-00 (15-00) (4-Lane Build)
 Route(s): STH 23
 Region/COUNTY(IES): NE / Fond du Lac - Sheboygan
 Location: @ CTH W - Loehr

Design Hour Turning Movement Data

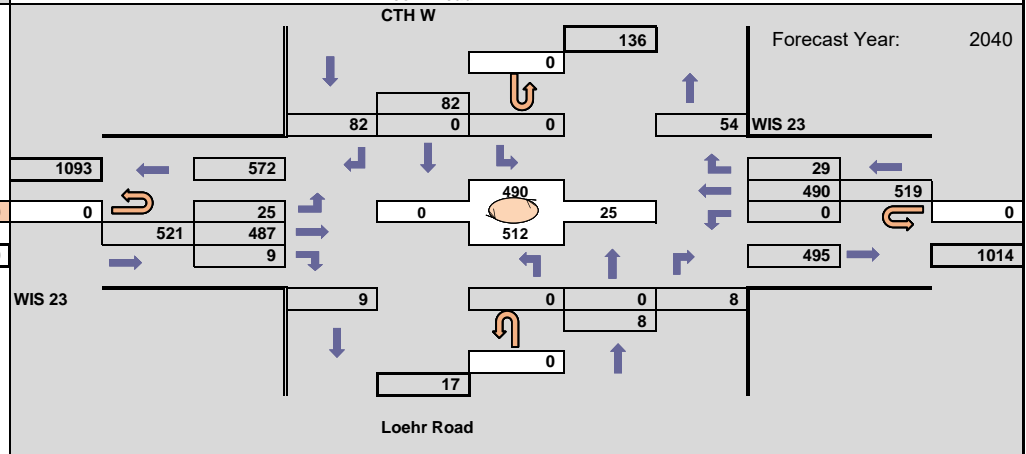
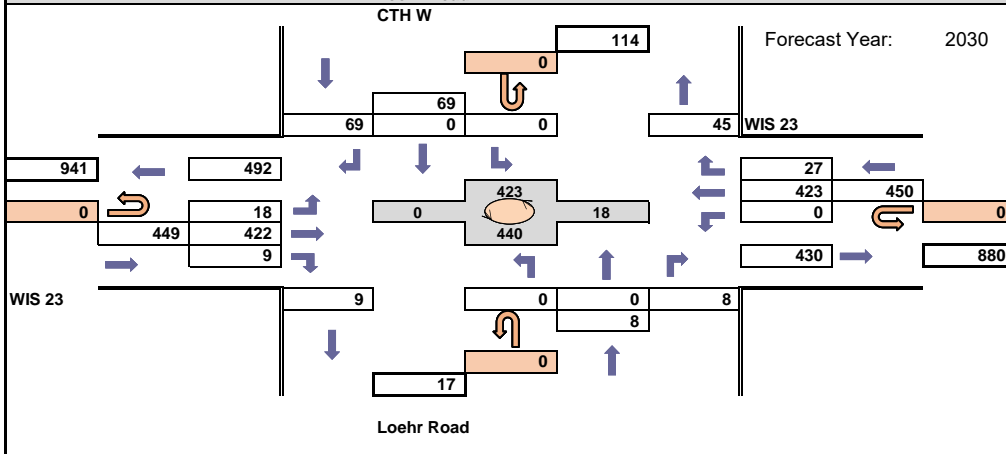
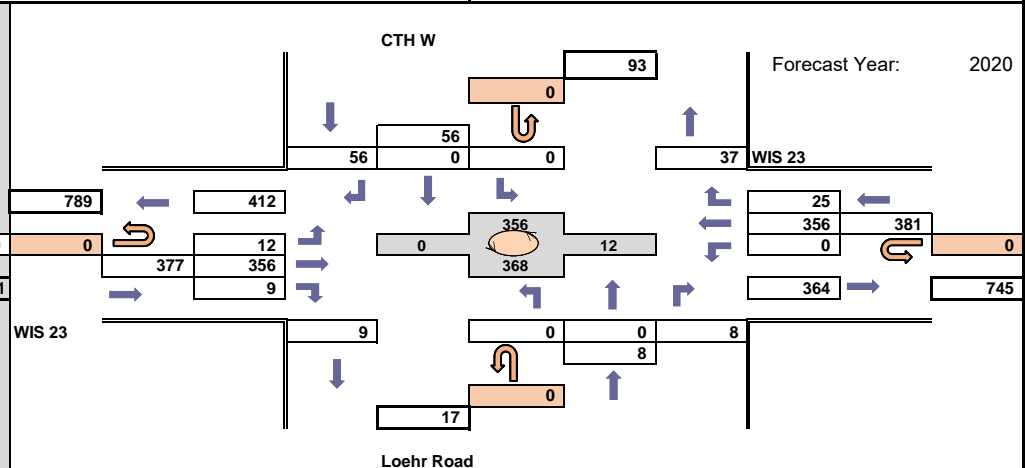
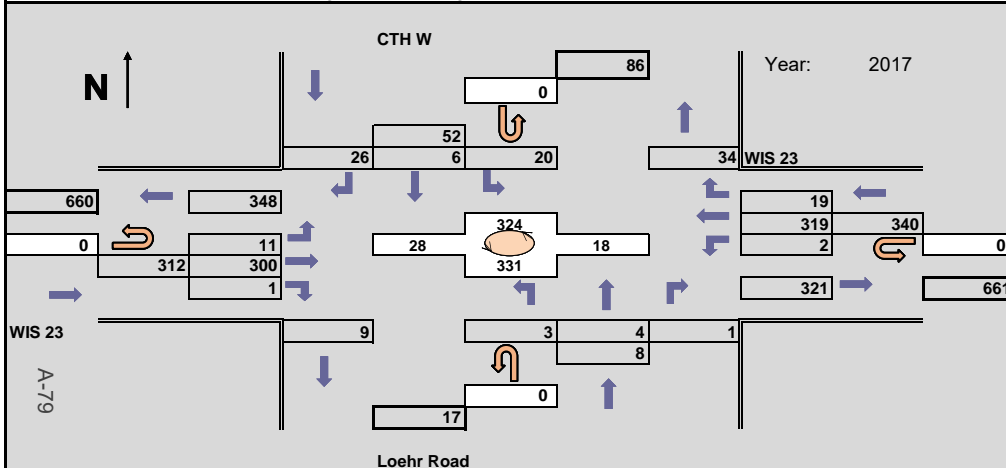

WisDot Bureau of Planning
 Traffic Forecasting Section
 Forecast by: Chris Chritton
 Phone: 608-266-0194
 Email: chris.chritton@dot.wi.gov

Projected PM Design Hour Traffic Volumes

 Indicates roundabout

Design Hour: 4:15-5:15pm

Forecast Completed: 4/6/2018

Project Description

Project ID(s): 1440-13-00 (15-00) (4-Lane Build)
 Route(s): STH 23
 Region/COUNTY(IES): NE / Fond du Lac - Sheboygan
 Location: @ CTH W - Loehr

Design Hour Turning Movement Data

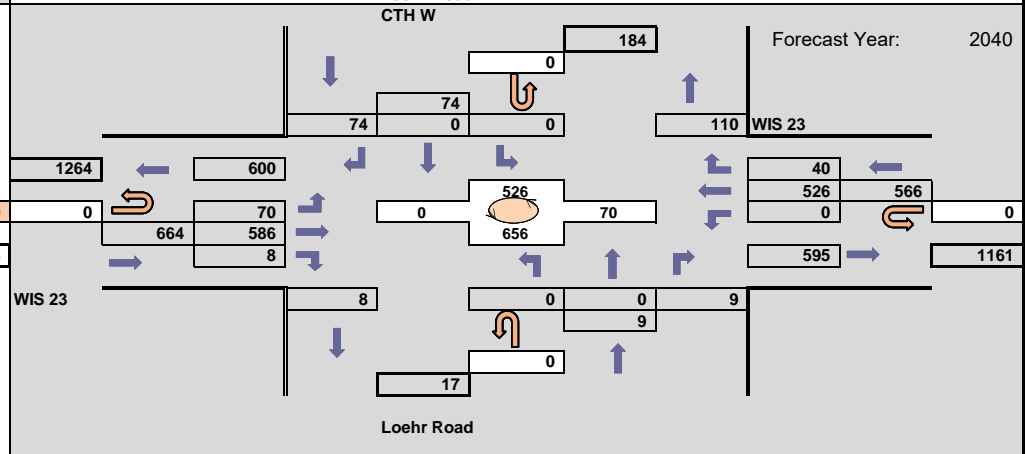
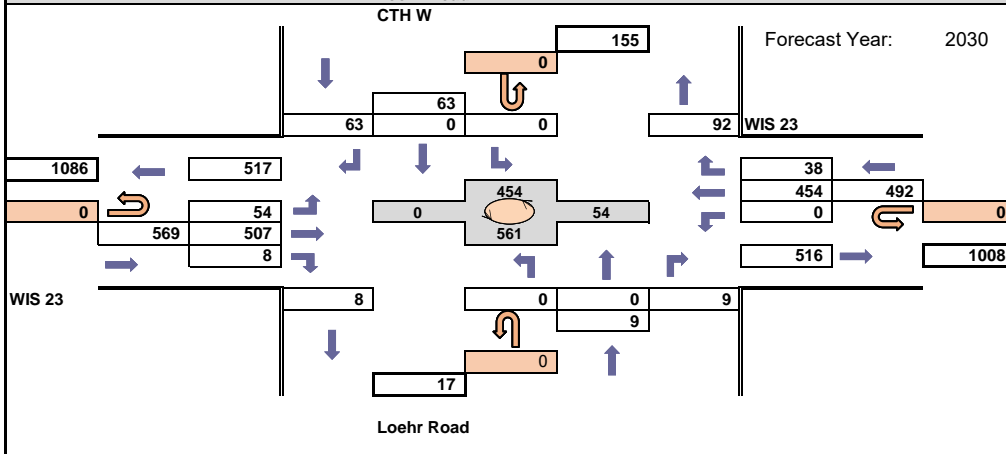
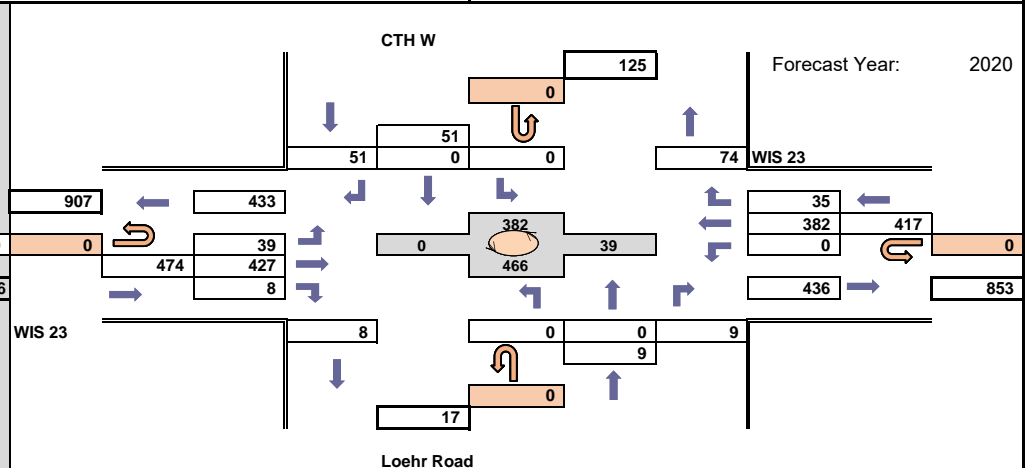
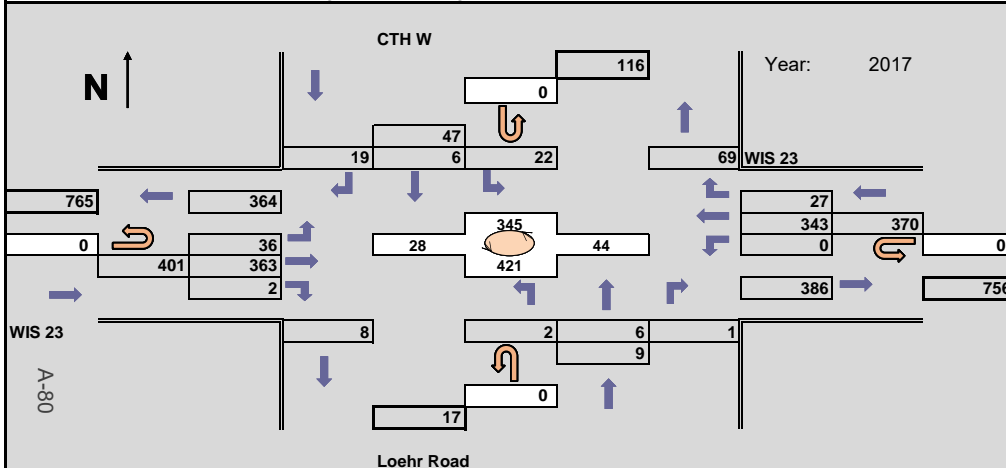

WisDot Bureau of Planning
 Traffic Forecasting Section
 Forecast by: Chris Chritton
 Phone: 608-266-0194
 Email: chris.chritton@dot.wi.gov

Projected AM Design Hour Traffic Volumes

 Indicates roundabout

Design Hour: 6:45-7:45am

Forecast Completed: 4/6/2018

Project Description

Project ID(s): 1440-13-00 (15-00) (4-Lane Build)
 Route(s): STH 23
 Region/COUNTY(IES): NE / Fond du Lac - Sheboygan
 Location: @ CTH G - North Roundabout

Design Hour Turning Movement Data

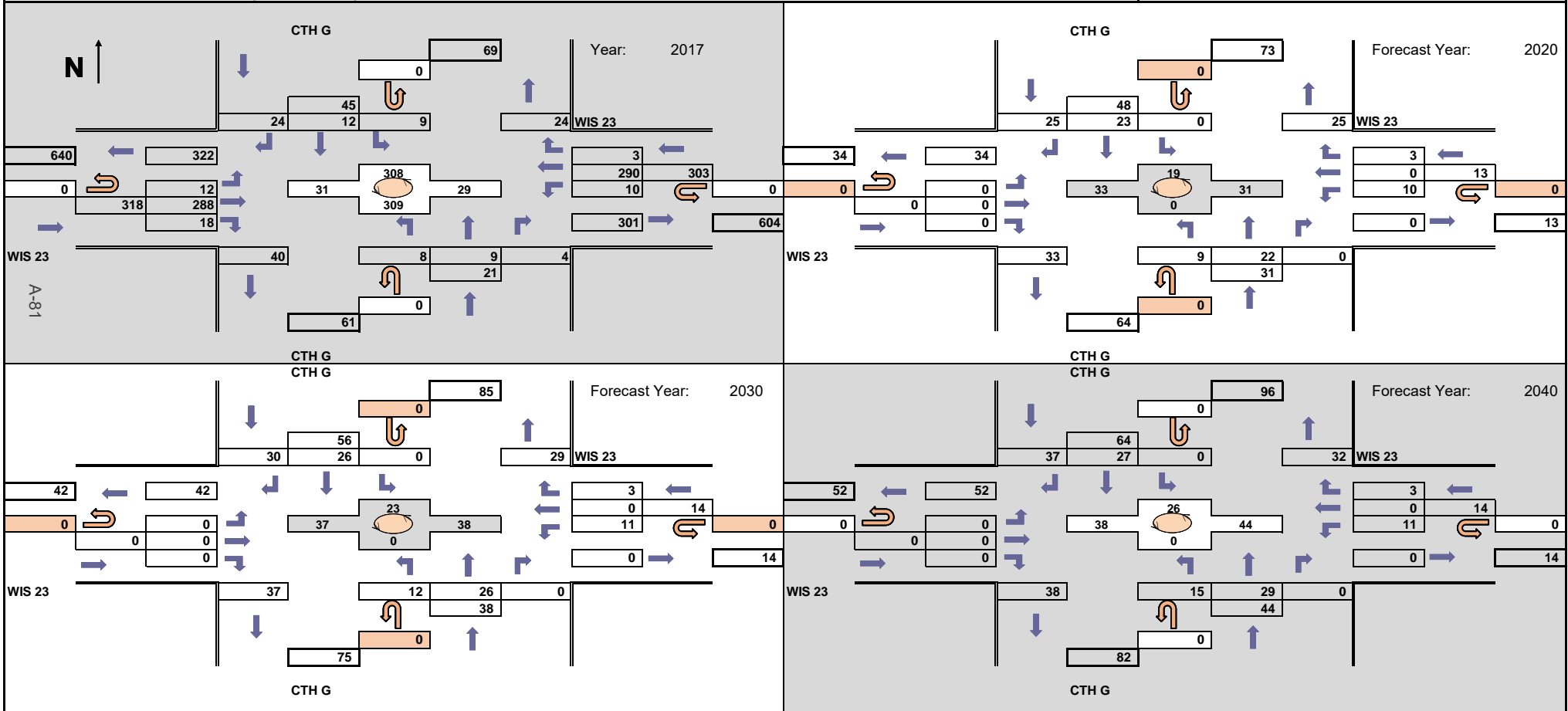

WisDot Bureau of Planning
 Traffic Forecasting Section
 Forecast by: Chris Chritton
 Phone: 608-266-0194
 Email: chris.chritton@dot.wi.gov

Projected PM Design Hour Traffic Volumes

 Indicates roundabout

Design Hour: 4:15-5:15pm

Forecast Completed: 4/6/2018

Project Description

Project ID(s): 1440-13-00 (15-00) (4-Lane Build)
 Route(s): STH 23
 Region/COUNTY(IES): NE / Fond du Lac - Sheboygan
 Location: @ CTH G - North Roundabout

Design Hour Turning Movement Data

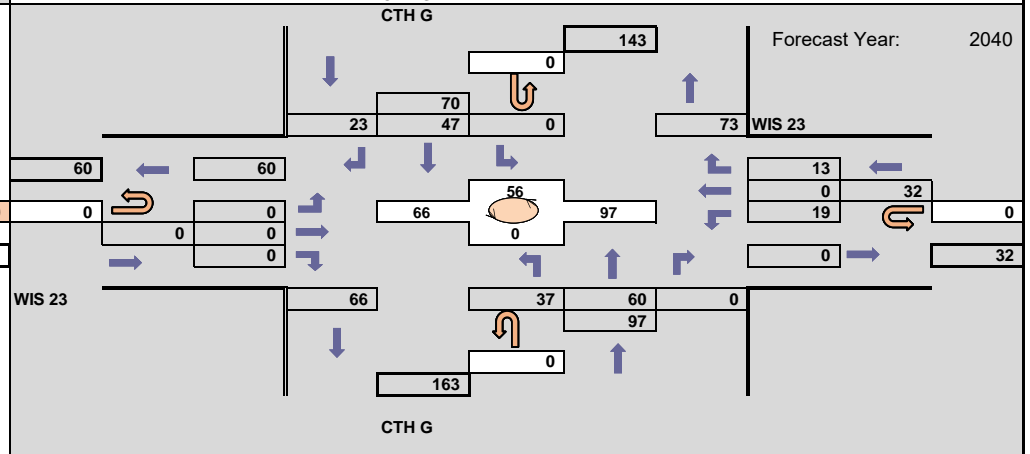
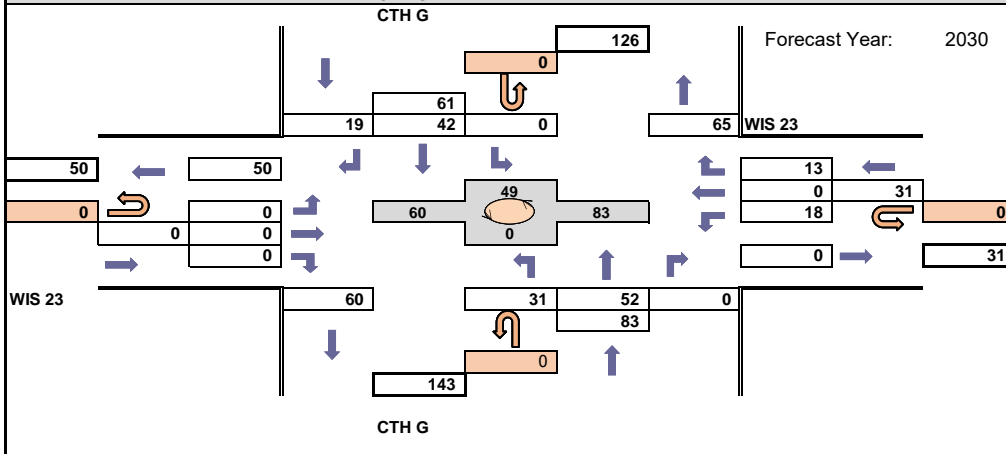
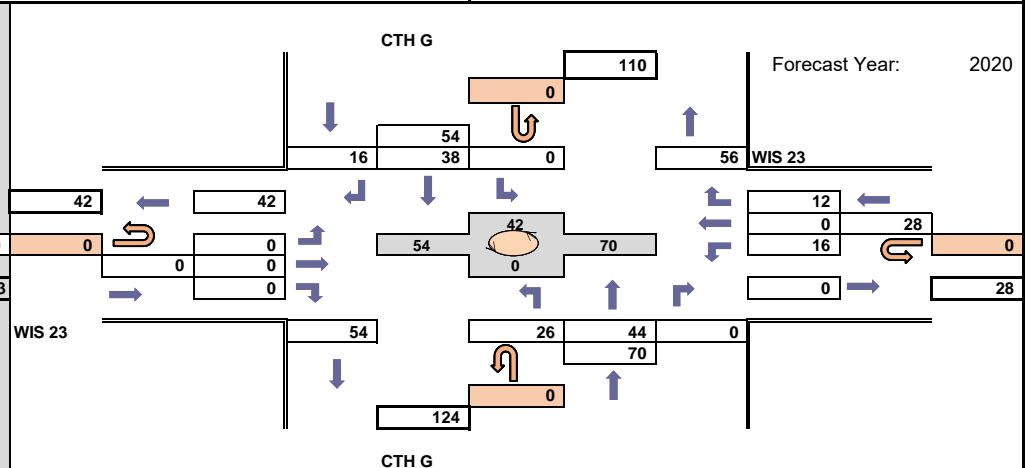
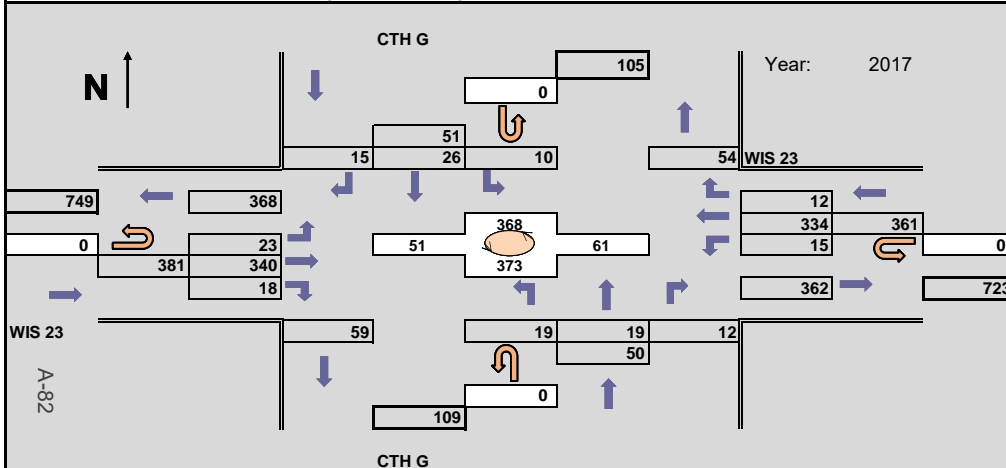

WisDot Bureau of Planning
 Traffic Forecasting Section
 Forecast by: Chris Chritton
 Phone: 608-266-0194
 Email: chris.chritton@dot.wi.gov

Projected AM Design Hour Traffic Volumes

 Indicates roundabout

Design Hour: 6:45-7:45am

Forecast Completed: 4/6/2018

Project Description

Project ID(s): 1440-13-00 (15-00) (4-Lane Build)
 Route(s): STH 23
 Region/COUNTY(IES): NE / Fond du Lac - Sheboygan
 Location: @ CTH G - South Roundabout

Design Hour Turning Movement Data

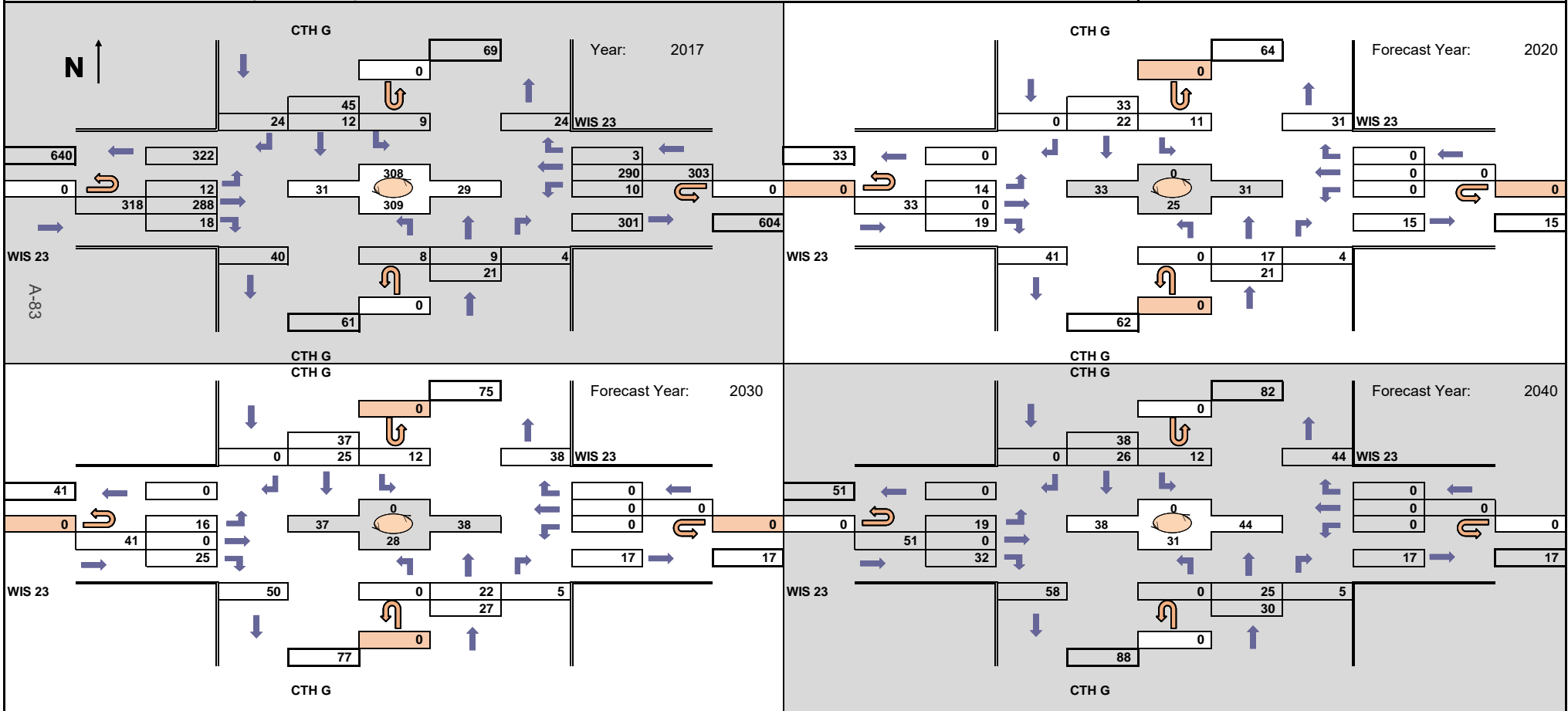

WisDot Bureau of Planning
 Traffic Forecasting Section
 Forecast by: Chris Chritton
 Phone: 608-266-0194
 Email: chris.chritton@dot.wi.gov

Projected PM Design Hour Traffic Volumes

 Indicates roundabout

Design Hour: 4:15-5:15pm

Forecast Completed: 4/6/2018

Project Description

Project ID(s): 1440-13-00 (15-00) (4-Lane Build)
 Route(s): STH 23
 Region/COUNTY(IES): NE / Fond du Lac - Sheboygan
 Location: @ CTH G - South Roundabout

Design Hour Turning Movement Data

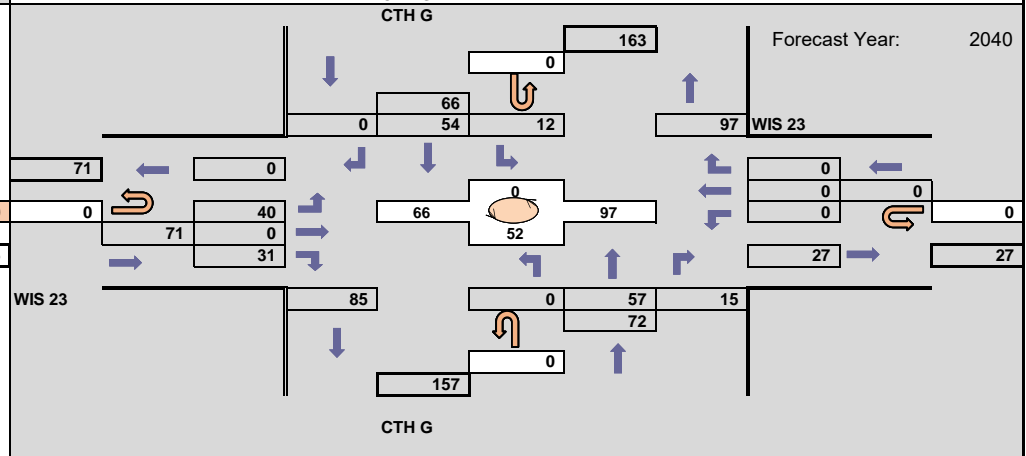
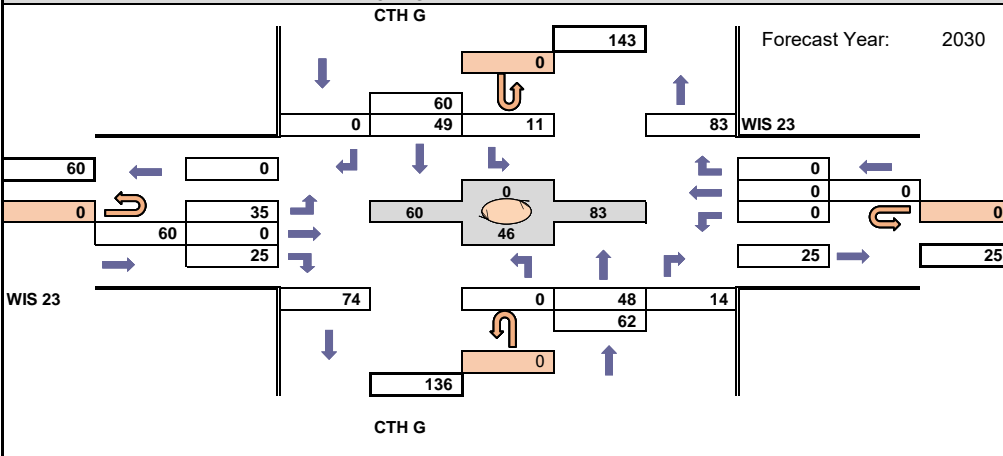
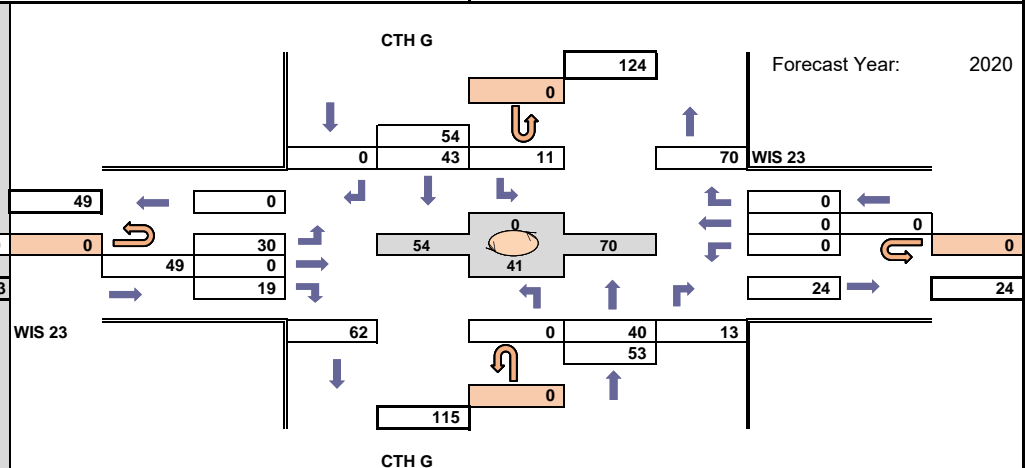
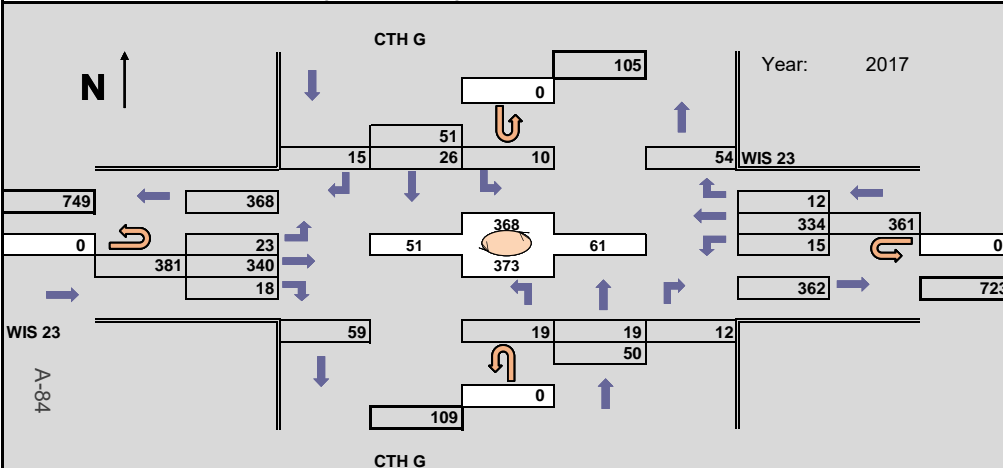

CTH W North/Loehr Rd (AM)		
Year	West J-Turn	East J-Turn
2020	28	21
2030	29	22
2040	30	23

CTH W North/Loehr Rd (PM)		
Year	West J-Turn	East J-Turn
2020	30	25
2030	33	26
2040	35	27

West J-Turn has existing CTH W North/Loehr Rd SBT and SBL

East J-Turn has existing CTH W North/Loehr Rd NBT and NBL as well as CTH W South/Hinn Rd NBT, NBL, and EBL

**ATTACHMENT G
WISDOT BTO PEER REVIEW**

From: Rouleau, Benjamin M - DOT
To: [Urban, Joseph M.](#); [Lipke, Bryan - DOT](#); [Michaelson, Jill - DOT](#)
Cc: [DOT WIS 23-Major 1440-13/15-00/01](#); [Lynch, Tom](#); [Petersen, Joan](#); [Kobryn, Jennifer](#); [DOT Traffic Analysis & Modeling](#); [Szymkowski, Rebecca - DOT](#)
Subject: RE: WIS 23 - 2-Lane Operations Results (Draft 3-26-2018)
Date: Thursday, April 12, 2018 3:56:16 PM
Attachments: [image001.png](#)
[dt1887_4-lane_4-12-18_2nd_review.docx](#)
[dt1887_Intersections_4-12-18_2nd_review.docx](#)

Joe,

Sounds good on everything. See attached for final DT1887s.

On the J-Turns, Vicki and I have discussed this and it's a little bit unclear what speed (posted or design or something else) should actually be used for calculating the EDTT. But 60 and 65 (ceiling) seem fine.

Ben

From: Urban, Joseph M. [mailto:Joseph.Urban@strand.com]
Sent: Thursday, April 12, 2018 9:57 AM
To: Rouleau, Benjamin M - DOT <Benjamin.Rouleau@dot.wi.gov>; Lipke, Bryan - DOT <Bryan.Lipke@dot.wi.gov>; Michaelson, Jill - DOT <Jill.Michaelson@dot.wi.gov>
Cc: DOT WIS 23-Major 1440-13/15-00/01 <DOTWIS23-Major1440-13/15-00/01@dot.wi.gov>; Lynch, Tom <Tom.Lynch@strand.com>; Petersen, Joan <Joan.Petersen@strand.com>; Kobryn, Jennifer <Jennifer.kobryn@strand.com>; DOT Traffic Analysis & Modeling <DOTTrafficAnalysisModeling@dot.wi.gov>; Szymkowski, Rebecca - DOT <Rebecca.Szymkowski@dot.wi.gov>
Subject: RE: WIS 23 - 2-Lane Operations Results (Draft 3-26-2018)

Thanks again for the quick turnaround on the comments Ben.

We've reviewed and have made a couple of revisions to the J-turn analysis files and results, mainly with the speeds associated with the Hybrid Alternative. Overall, the results are similar in terms of delay, travel time, and LOS. Please see the attached DT1887 responses for more discussion on the intersection revisions and for the 4-lane analysis at CTH G.

For the TWSC at the interchange ramp terminals, we propose making a note in the environmental document that roundabouts or TWSC could be considered (as design progresses).

Let me know if you want to discuss or if you have any questions. Thanks,

Joe

From: Rouleau, Benjamin M - DOT <Benjamin.Rouleau@dot.wi.gov>
Sent: Wednesday, April 11, 2018 4:26 PM

To: Urban, Joseph M. <Joseph.Urban@strand.com>; Lipke, Bryan - DOT <Bryan.Lipke@dot.wi.gov>; Michaelson, Jill - DOT <Jill.Michaelson@dot.wi.gov>
Cc: DOT WIS 23-Major 1440-13/15-00/01 <DOTWIS23-Major1440-13/15-00/01@dot.wi.gov>; Lynch, Tom <Tom.Lynch@strand.com>; Petersen, Joan <Joan.Petersen@strand.com>; Kobryn, Jennifer <Jennifer.Kobryn@strand.com>; DOT Traffic Analysis & Modeling <DOTTrafficAnalysisModeling@dot.wi.gov>; Szymkowski, Rebecca - DOT <Rebecca.Szymkowski@dot.wi.gov>
Subject: RE: WIS 23 - 2-Lane Operations Results (Draft 3-26-2018)

Joe and Bryan,

See attached. Overall, the files are looking good – but I do have a few questions and comments.

Also, I'm not sure if I've brought this up before, but with the volumes included for them, I would imagine that TWSC would be more than sufficient for control at the interchange ramp terminals.

Thanks,

Ben

Benjamin M. Rouleau, E. I.
Traffic Operations and Analysis Engineer
Wisconsin Department of Transportation
Bureau of Traffic Operations
4822 Madison Yards Way, 5th Floor South
Madison, WI 53705
Office: 608.266.7717
Cell: 802.272.8782
Email: benjamin.rouleau@dot.wi.gov

From: Urban, Joseph M. [<mailto:Joseph.Urban@strand.com>]
Sent: Tuesday, April 10, 2018 1:01 PM
To: Rouleau, Benjamin M - DOT <Benjamin.Rouleau@dot.wi.gov>; Lipke, Bryan - DOT <Bryan.Lipke@dot.wi.gov>; Michaelson, Jill - DOT <Jill.Michaelson@dot.wi.gov>
Cc: DOT WIS 23-Major 1440-13/15-00/01 <DOTWIS23-Major1440-13/15-00/01@dot.wi.gov>; Lynch, Tom <Tom.Lynch@strand.com>; Petersen, Joan <Joan.Petersen@strand.com>; Kobryn, Jennifer <Jennifer.kobryn@strand.com>; DOT Traffic Analysis & Modeling <DOTTrafficAnalysisModeling@dot.wi.gov>; Szymkowski, Rebecca - DOT <Rebecca.Szymkowski@dot.wi.gov>
Subject: RE: WIS 23 - 2-Lane Operations Results (Draft 3-26-2018)

Thanks Ben for the quick review on the two-lane mainline files. I've addressed the comment on Page 17 of the memo that you noted below.

Strand has completed updates to the four-lane highway and intersection analyses as well. Attached are the following files:

- An update to the “01” file from the previous emails with revisions to the 4-lane volume development worksheet.
- **“2018-04-10 WIS 23 Traffic Modeling Tech Memo (Draft with Attachments).pdf”** - draft tech memo still with highlighted changes and attachments. The intersection analysis section and Attachment F have been revised since the previous version.
- Zip files that contain draft 4-lane highway and draft intersection HCS files based on the 4/6/2018 forecasts. The intersection analysis files include the following for the 2040 AM and PM peak hours:
 - No-Build and Passing Lane Alternatives: two-way stop controlled analysis at 3 intersections.
 - Hybrid and 4-Lane Alternatives: single-lane roundabout analysis at interchange ramp terminals (4 total intersections). RCUT, or J-Turn, analysis at 1 intersection.
 - General intersection two-way stop controlled analysis with varying turning movement volumes for a two-lane and four-lane scenario.
- **“2018-04-10 Draft Operations Analysis Results.zip”** - contains a summary of the mainline MOEs and a summary of the intersection MOEs.

I believe your review in November covered most of the same files. The only modeling difference may be that the RCUT analysis/results for the County W/Loehr Road J-Turn are updated to reflect the guidance in the HCM6. Some other improvements were made to the presentation of the materials in Attachment F of the memo and the corresponding MOE tables to better align with how information may be presented in the environmental document.

Let me know if you have any questions during your review or if you need anything else. Thanks!

Joe

From: Rouleau, Benjamin M - DOT <Benjamin.Rouleau@dot.wi.gov>
Sent: Monday, April 9, 2018 4:29 PM
To: Urban, Joseph M. <Joseph.Urban@strand.com>; Lipke, Bryan - DOT <Bryan.Lipke@dot.wi.gov>; Michaelson, Jill - DOT <Jill.Michaelson@dot.wi.gov>
Cc: DOT WIS 23-Major 1440-13/15-00/01 <DOTWIS23-Major1440-13/15-00/01@dot.wi.gov>; Lynch, Tom <Tom.Lynch@strand.com>; Petersen, Joan <Joan.Petersen@strand.com>; Kobryn, Jennifer <Jennifer.Kobryn@strand.com>; DOT Traffic Analysis & Modeling <DOTTrafficAnalysisModeling@dot.wi.gov>; Szymkowski, Rebecca - DOT <Rebecca.Szymkowski@dot.wi.gov>
Subject: RE: WIS 23 - 2-Lane Operations Results (Draft 3-26-2018)

Joe, Bryan, and Jill,

See attached for the DT1887 form. I have reviewed the files and everything appears to be in order. The HCM equations appear to bounce around a bit with these small changes, but I have checked into it some and don't see any red flags.

I did note that, in the memo, item #7 on page 17 ends with an incomplete sentence. It looks like this was also the case in the 3/26 memo – sorry for having overlooked that previously.

Let me know when the other files are ready for review.

If there are any questions, just let me know.

Ben

Ben Rouleau
Traffic Operations and Analysis Engineer
WisDOT Bureau of Traffic Operations
608.266.7717

From: Urban, Joseph M. [<mailto:Joseph.Urban@strand.com>]
Sent: Monday, April 09, 2018 10:19 AM
To: Rouleau, Benjamin M - DOT <Benjamin.Rouleau@dot.wi.gov>; DOT Traffic Analysis & Modeling <DOTTrafficAnalysisModeling@dot.wi.gov>; Szymkowski, Rebecca - DOT <Rebecca.Szymkowski@dot.wi.gov>
Cc: Lipke, Bryan - DOT <Bryan.Lipke@dot.wi.gov>; Michaelson, Jill - DOT <Jill.Michaelson@dot.wi.gov>; DOT WIS 23-Major 1440-13/15-00/01 <DOTWIS23-Major1440-13/15-00/01@dot.wi.gov>; Lynch, Tom <Tom.Lynch@strand.com>; Petersen, Joan <Joan.Petersen@strand.com>; Kobryn, Jennifer <Jennifer.kobryn@strand.com>
Subject: RE: WIS 23 - 2-Lane Operations Results (Draft 3-26-2018)

Hi Ben,

Strand has completed updates to the WIS 23 two-lane mainline operations analysis based on the revised TDM-only forecasts from 4/6/2018. Please see below a description of the attached files, which are similar to the 3/26 submittal.

- **“01 - Traffic Volumes - 2018 April 6th Forecasts_App A”** - Volume development sheets for each alternative.
- **“02 - _Segment Forecasts (4-6-2018) - NERTDM only”** - The NERTDM-only segment forecast reports extracted from Appendix A of the forecast document, provided by TFS to Strand on 4/6/2018.
- **“03 - __Two-Lane Analysis Checklist 4-08-2018”** - Revised two-lane mainline input checklist with the 4/6/2018 traffic volumes.
- **“04a and 04b” Files** - Draft operations results for the two-lane analysis. The “04a” file is a summary that shows the worst-case segment in each direction. The “04b” file shows a more detailed breakdown of the results from each individual HCS file.
- **“05 - WIS 23 Two-Lane HCS Files (04-08-2018 Final Draft).zip”** - The two-lane HCS files revised to reflect the latest traffic forecasts.
- **“06 - 2018-04-09 WIS 23 Traffic Modeling Tech Memo (Draft changes).pdf”** - Similar memo from your last review on 3/26 that includes highlighted changes in comparison to the 11/9/2017 version of the memo. References to the traffic forecast date and the mainline

AADT/DHV volumes have been revised. See the email below regarding some detail on the check related to the version of HCS. For this analysis Version 7.5 was used.

The intersection and 4-lane operations modeling is in progress based on the AM and PM intersection forecasts received yesterday. I'd expect to be submitting the analysis files tomorrow for your review.

Let me know if you have any questions or if you need anything else. Thanks!

Joe

From: Urban, Joseph M.
Sent: Tuesday, April 3, 2018 10:31 AM
To: Lipke, Bryan - DOT <Bryan.Lipke@dot.wi.gov>; Michaelson, Jill - DOT <Jill.Michaelson@dot.wi.gov>
Cc: DOT WIS 23-Major 1440-13/15-00/01 <DOTWIS23-Major1440-13/15-00/01@dot.wi.gov>; Lynch, Tom <Tom.Lynch@strand.com>; Petersen, Joan <Joan.Petersen@strand.com>; Kobryn, Jennifer <Jennifer.Kobryn@strand.com>
Subject: RE: WIS 23 - 2-Lane Operations Results (Draft 3-26-2018)

Hi Bryan and Jill,

Strand has updated the two-lane operations analysis files to reflect the most recent version of HCS (version 7.5) that BTO used in their review. We've confirmed that there are no changes in operations compared to the previously submitted analysis files, which were completed in HCS version 7.3.

Attached are the HCS version 7.5 two-lane analysis files and revised checklist for your records. Let me know if you have any questions, otherwise these files could be passed on to BTO if needed to close out the two-lane peer review.

Thanks,

Joe

From: Rouleau, Benjamin M - DOT <Benjamin.Rouleau@dot.wi.gov>
Sent: Tuesday, March 27, 2018 3:43 PM
To: Lipke, Bryan - DOT <Bryan.Lipke@dot.wi.gov>; DOT Traffic Analysis & Modeling <DOTTrafficAnalysisModeling@dot.wi.gov>; Szymkowski, Rebecca - DOT <Rebecca.Szymkowski@dot.wi.gov>
Cc: DOT WIS 23-Major 1440-13/15-00/01 <DOTWIS23-Major1440-13/15-00/01@dot.wi.gov>; Lynch, Tom <Tom.Lynch@strand.com>; Petersen, Joan <Joan.Petersen@strand.com>; Kobryn, Jennifer <Jennifer.Kobryn@strand.com>; Urban, Joseph M. <Joseph.Urban@strand.com>; Michaelson, Jill - DOT <Jill.Michaelson@dot.wi.gov>
Subject: RE: WIS 23 - 2-Lane Operations Results (Draft 3-26-2018)

Bryan,

See attached for the DT1887. I didn't find any issues with the analysis. However, a couple things to note:

- Page 3 of the tech memo notes that the most recent version of HCS is 7.3 as of March 19, 2018. However, version 7.5 was released on 2/28/18, I believe. This is the version that I used to review the model. I didn't come across any differences in results due to the different versions, but this should be updated.
- The "Two-Lane Analysis Checklist" file has Lu and Lde switched for Hybrid 2C: CTH G to CL EB. It is correct in Table 6 of the tech memo and, most importantly, in the HCS files. This error appears to have been present in previous iterations of this checklist table.

If you or Strand have any questions, please let me know.

Thanks,

Ben

Benjamin M. Rouleau, E. I.
Traffic Operations and Analysis Engineer
Wisconsin Department of Transportation
Bureau of Traffic Operations
4822 Madison Yards Way, 5th Floor South
Madison, WI 53705
Office: 608.266.7717
Cell: 802.272.8782
Email: benjamin.rouleau@dot.wi.gov

From: Lipke, Bryan - DOT
Sent: Monday, March 26, 2018 4:33 PM
To: DOT Traffic Analysis & Modeling <DOTTrafficAnalysisModeling@dot.wi.gov>; Szymkowski, Rebecca - DOT <Rebecca.Szymkowski@dot.wi.gov>; Rouleau, Benjamin M - DOT <Benjamin.Rouleau@dot.wi.gov>
Cc: DOT WIS 23-Major 1440-13/15-00/01 <DOTWIS23-Major1440-13/15-00/01@dot.wi.gov>; Lynch, Tom <Tom.Lynch@strand.com>; Petersen, Joan <Joan.Petersen@strand.com>; Kobryn, Jennifer <Jennifer.Kobryn@strand.com>; Urban, Joseph M. <Joseph.Urban@strand.com>; Michaelson, Jill - DOT <Jill.Michaelson@dot.wi.gov>
Subject: FW: WIS 23 - 2-Lane Operations Results (Draft 3-26-2018)

Ben and Rebecca,

Transmitting Strands updated run of WIS 23 Traffic Operations based off the new traffic forecast information. Please keep me in the loop but work directly with Joe Urban if the questions or follow-up by phone or email can expedite BTO/Traffic Analysis Groups review. Again, this is the mainline only and we will reengage you for review of the side-road analysis soon when developed. Thank you for your review.

Bryan Lipke, P.E.

Planning Project Manager
Wisconsin Department of Transportation
Northeast Region
Phone: (920) 492-5703
Cell Phone: (920) 360-9196
Bryan.Lipke@dot.wi.gov
wisconsin.gov

If this is related to a records request, please email: dotdtsdnerecords@dot.wi.gov

From: Urban, Joseph M. [<mailto:Joseph.Urban@strand.com>]

Sent: Monday, March 26, 2018 4:18 PM

To: Lipke, Bryan - DOT <Bryan.Lipke@dot.wi.gov>; Michaelson, Jill - DOT <Jill.Michaelson@dot.wi.gov>

Cc: DOT WIS 23-Major 1440-13/15-00/01 <DOTWIS23-Major1440-13/15-00/01@dot.wi.gov>; Lynch, Tom <Tom.Lynch@strand.com>; Petersen, Joan <Joan.Petersen@strand.com>; Kobryn, Jennifer <Jennifer.Kobryn@strand.com>

Subject: [WARNING: ATTACHMENT(S) MAY CONTAIN MALWARE]WIS 23 - 2-Lane Operations Results (Draft 3-26-2018)

Hi Bryan and Jill,

Strand has completed updates to the 2-lane mainline operations analysis for WIS 23 based on the forecast documentation provided by WisDOT TFS on 3/19/2018. The volumes used in the operations analysis were from Appendix A of the forecasting document, which are based only on the Northeast Region Travel Demand Model (NERTDM). I've attached several files for WisDOT BTO's reference and review, a description of each is below.

- **"01 - Traffic Volumes - 2018 Mar 19th Forecasts_App A"** - Volume development sheets that are updated for the No-Build, Passing Lane, and Hybrid alternatives. The 4-Lane worksheet will be updated once intersection traffic forecasts are received because service ramp volumes are included in the 4-lane analyses.
- **"02 - App A_Segment Forecasts (TDM only).pdf"** - The NERTDM-only segment forecast reports extracted from Appendix A of the 3/19/2018 forecast document.
- **"03 - __Two-Lane Analysis Checklist 3-23-2018"** - Two-lane analysis input checklist provided for the first BTO review that has been updated for traffic volumes.
- **"04a and 04b" Files** - Draft operations results for the two-lane analysis. The "04a" file is a summary that shows the worst-case segment in each direction. The "04b" file shows a more detailed breakdown of the results from each individual HCS file.
- **"05 - WIS 23 Two-Lane HCS Files (03-26-2018 Draft).zip"** - The updated draft two-lane HCS files based on the NERTDM-only segment forecasts from 3/19/2018.
- **"06 - 2018-03-26 WIS 23 Traffic Modeling Tech Memo (Draft changes).pdf"** - Draft updates to the traffic modeling tech memo based on the 3/16/2018 WisDOT FDM updates and the 3/19/2018 traffic forecasts. Changes from the 11/9/2017 version of the memo are highlighted or struck out at this time. Please note that the last page and attachments to the memo are a

work in progress and will be updated once the intersection traffic forecasts are received and the intersection/4-lane operations analysis is completed.

Let me know if you have any questions prior to the transmittal. Thanks!

Joe



Joseph Urban, P.E.

Strand Associates, Inc.®

608.251.4843 ext. 1091

joseph.urban@strand.com | www.strand.com

Excellence in Engineering Since 1946.



HCM ANALYSIS REVIEW CHECKLIST

Wisconsin Department of Transportation (WisDOT)
DT1887 8/2015

Project ID(s) 1440-13-00		Region: NE		Date Reviewed (m/d/yyyy)		
Project Name/Description WIS 23, Fond du Lac to Plymouth		Highway(s) WIS 23		1 st Review 4/9/2017	2 nd Review	3 rd Review
Reviewed By: WisDOT BTO		Lead Reviewer		Lead Analyst		
Name (First, MI, Last) Ben Rouleau		Name (First, MI, Last) Joe Urban		Name (First, MI, Last) Bryan Lipke		
Organization/Firm WisDOT BTO		Organization/Firm Strand Associates		Region/Bureau NE Region		
(Area Code) Telephone Number (608) 266-7717		(Area Code) Telephone Number (608) 251-4843		(Area Code) Telephone Number (920) 492-5703		
Email Address benjamin.rouleau@dot.wi.gov		Email Address joseph.urban@strand.com		Email Address bryan.lipke@dot.wi.gov		

TRAFFIC MODEL DESCRIPTION

Model Completion/Revision Date (m/d/yyyy) 4/8/2018	Analysis Year(s) 2017, 2040	Analysis Scenario/Alternative 2-lane analysis: Existing, No-Build, Passing Lanes (w/ and w/o lefts), Hybrid
---	--------------------------------	--

A-95 Scope of Model (intersections, ramps, corridors, etc. being reviewed)
WIS 23 from County UU (Fond du Lac) to County P (Sheboygan)

Analysis Time Period (s)

Weekday AM Peak
 Weekday Midday Peak
 Weekday PM Peak
 Fri Peak
 Sat Peak
 Sun Peak
 Other: K30

Hours: _____ Hours: _____ Hours: _____ Hours: _____ Hours: _____ Hours: _____ Hours: _____

Analysis Tool(s) Utilized

HCS - Version: 7.5
 Synchro - Version/Build: _____
 Sidra - Version: _____
 Other: _____ - Version: _____

SUMMARY OF REVIEW

Item Reviewed	Overall Model Acceptability	Revision Required	Reviewer Comment(s)	Analyst Response(s)
Traffic Analysis Tool/Version	<input checked="" type="checkbox"/> <input type="checkbox"/> <input type="checkbox"/> Acceptable <input type="checkbox"/> <input type="checkbox"/> <input type="checkbox"/> Unacceptable <input type="checkbox"/> <input type="checkbox"/> <input type="checkbox"/> Conditionally Acceptable	<input checked="" type="checkbox"/> <input type="checkbox"/> <input type="checkbox"/> No <input type="checkbox"/> <input type="checkbox"/> <input type="checkbox"/> Yes	HCS 7.5 used for review.	
Lane Geometry	<input checked="" type="checkbox"/> <input type="checkbox"/> <input type="checkbox"/> Acceptable <input type="checkbox"/> <input type="checkbox"/> <input type="checkbox"/> Unacceptable <input type="checkbox"/> <input type="checkbox"/> <input type="checkbox"/> Conditionally Acceptable	<input checked="" type="checkbox"/> <input type="checkbox"/> <input type="checkbox"/> No <input type="checkbox"/> <input type="checkbox"/> <input type="checkbox"/> Yes		
	<input checked="" type="checkbox"/> <input type="checkbox"/> <input type="checkbox"/> Acceptable <input type="checkbox"/> <input type="checkbox"/> <input type="checkbox"/> Unacceptable	<input checked="" type="checkbox"/> <input type="checkbox"/> <input type="checkbox"/> No		

HCM ANALYSIS REVIEW CHECKLIST *(continued)*

Wisconsin Department of Transportation (WisDOT) **DT1887**

Traffic Volumes, % Trucks, Peak Hour Factor (PHF)	<input type="checkbox"/> <input type="checkbox"/> <input type="checkbox"/> Conditionally Acceptable	<input checked="" type="checkbox"/> <input type="checkbox"/> <input type="checkbox"/> Yes	PHF = 1 and PHF = 0.89 scenarios both reviewed for future conditions	
---	---	---	--	--

(continued on reverse side)

SUMMARY OF REVIEW *(continued)*

Item Reviewed	Overall Model Acceptability	Revision Required	Reviewer Comment(s)	Analyst Response(s)
Signal Parameters (including RTOR)	<input type="checkbox"/> <input type="checkbox"/> <input type="checkbox"/> Acceptable <input type="checkbox"/> <input type="checkbox"/> <input type="checkbox"/> Unacceptable <input type="checkbox"/> <input type="checkbox"/> <input type="checkbox"/> Conditionally Acceptable <input type="checkbox"/> <input type="checkbox"/> <input checked="" type="checkbox"/> N/A	<input checked="" type="checkbox"/> <input type="checkbox"/> <input type="checkbox"/> No <input type="checkbox"/> <input type="checkbox"/> <input type="checkbox"/> Yes		
Stop-Control/Roundabout Parameters	<input type="checkbox"/> <input type="checkbox"/> <input type="checkbox"/> Acceptable <input type="checkbox"/> <input type="checkbox"/> <input type="checkbox"/> Unacceptable <input type="checkbox"/> <input type="checkbox"/> <input type="checkbox"/> Conditionally Acceptable <input type="checkbox"/> <input type="checkbox"/> <input checked="" type="checkbox"/> N/A	<input checked="" type="checkbox"/> <input type="checkbox"/> <input type="checkbox"/> No <input type="checkbox"/> <input type="checkbox"/> <input type="checkbox"/> Yes		
Freeway/Highway Parameters	<input checked="" type="checkbox"/> <input type="checkbox"/> <input type="checkbox"/> Acceptable <input type="checkbox"/> <input type="checkbox"/> <input type="checkbox"/> Unacceptable <input type="checkbox"/> <input type="checkbox"/> <input type="checkbox"/> Conditionally Acceptable <input type="checkbox"/> <input type="checkbox"/> <input type="checkbox"/> N/A	<input checked="" type="checkbox"/> <input type="checkbox"/> <input type="checkbox"/> No <input type="checkbox"/> <input type="checkbox"/> <input type="checkbox"/> Yes		
Measures of Effectiveness (MOEs)	<input checked="" type="checkbox"/> <input type="checkbox"/> <input type="checkbox"/> Acceptable <input type="checkbox"/> <input type="checkbox"/> <input type="checkbox"/> Unacceptable <input type="checkbox"/> <input type="checkbox"/> <input type="checkbox"/> Conditionally Acceptable <input type="checkbox"/> <input type="checkbox"/> <input type="checkbox"/> N/A	<input checked="" type="checkbox"/> <input type="checkbox"/> <input type="checkbox"/> No <input type="checkbox"/> <input type="checkbox"/> <input type="checkbox"/> Yes		
Other:	<input type="checkbox"/> <input type="checkbox"/> <input type="checkbox"/> Acceptable <input type="checkbox"/> <input type="checkbox"/> <input type="checkbox"/> Unacceptable <input type="checkbox"/> <input type="checkbox"/> <input type="checkbox"/> Conditionally Acceptable	<input type="checkbox"/> <input type="checkbox"/> <input type="checkbox"/> No <input type="checkbox"/> <input type="checkbox"/> <input type="checkbox"/> Yes		
Overall Model	<input checked="" type="checkbox"/> <input type="checkbox"/> <input type="checkbox"/> Acceptable <input type="checkbox"/> <input type="checkbox"/> <input type="checkbox"/> Unacceptable <input type="checkbox"/> <input type="checkbox"/> <input type="checkbox"/> Conditionally Acceptable	<input checked="" type="checkbox"/> <input type="checkbox"/> <input type="checkbox"/> No <input type="checkbox"/> <input type="checkbox"/> <input type="checkbox"/> Yes		

A-96



HCM ANALYSIS REVIEW CHECKLIST

Wisconsin Department of Transportation (WisDOT)
DT1887 8/2015

Project ID(s) 1440-13-00		Region: NE		Date Reviewed (m/d/yyyy)		
Project Name/Description WIS 23, Fond du Lac to Plymouth		Highway(s) WIS 23		1 st Review 4/11/2018	2 nd Review 4/12/2018	3 rd Review
Reviewed By: WisDOT BTO						
Lead Reviewer	Name (First, MI, Last) Ben Rouleau	Lead Analyst	Name (First, MI, Last) Joe Urban	Region Contact	Name (First, MI, Last) Bryan Lipke	
	Organization/Firm WisDOT BTO		Organization/Firm Strand Associates		Region/Bureau NE Region	
	(Area Code) Telephone Number (608) 266-7717		(Area Code) Telephone Number (608) 251-4843		(Area Code) Telephone Number (920) 492-5703	
	Email Address benjamin.rouleau@dot.wi.gov		Email Address joseph.urban@strand.com		Email Address bryan.lipke@dot.wi.gov	

TRAFFIC MODEL DESCRIPTION

Model Completion/Revision Date (m/d/yyyy) 4/11/2018	Analysis Year(s) 2040	Analysis Scenario/Alternative Build
--	--------------------------	--

Scope of Model (intersections, ramps, corridors, etc. being reviewed)
WIS 23 from County UU (Fond du Lac) to County P (Sheboygan); CTH G WB merge, CTH G EB diverge, CTH UU WB merge, CTH UU EB diverge, east of CTH UU basic, east of CTH G basic

Analysis Time Period (s)

Weekday AM Peak
 Weekday Midday Peak
 Weekday PM Peak
 Fri Peak
 Sat Peak
 Sun Peak
 Other: K30

Hours: _____ Hours: _____ Hours: _____ Hours: _____ Hours: _____ Hours: _____ Hours: _____

Analysis Tool(s) Utilized

HCS - Version: 7.5
 Synchro - Version/Build: _____
 Sidra - Version: _____
 Other: _____ - Version: _____

SUMMARY OF REVIEW

Item Reviewed	Overall Model Acceptability	Revision Required	Reviewer Comment(s)	Analyst Response(s)
Traffic Analysis Tool/Version	<input checked="" type="checkbox"/> <input checked="" type="checkbox"/> <input type="checkbox"/> Acceptable <input type="checkbox"/> <input type="checkbox"/> <input type="checkbox"/> Unacceptable <input type="checkbox"/> <input type="checkbox"/> <input type="checkbox"/> Conditionally Acceptable	<input checked="" type="checkbox"/> <input checked="" type="checkbox"/> <input type="checkbox"/> No <input type="checkbox"/> <input type="checkbox"/> <input type="checkbox"/> Yes		
Lane Geometry	<input checked="" type="checkbox"/> <input checked="" type="checkbox"/> <input type="checkbox"/> Acceptable <input type="checkbox"/> <input type="checkbox"/> <input type="checkbox"/> Unacceptable <input type="checkbox"/> <input type="checkbox"/> <input type="checkbox"/> Conditionally Acceptable	<input checked="" type="checkbox"/> <input checked="" type="checkbox"/> <input type="checkbox"/> No <input type="checkbox"/> <input type="checkbox"/> <input type="checkbox"/> Yes		
	<input type="checkbox"/> <input checked="" type="checkbox"/> <input type="checkbox"/> Acceptable <input type="checkbox"/> <input type="checkbox"/> <input type="checkbox"/> Unacceptable	<input checked="" type="checkbox"/> <input checked="" type="checkbox"/> <input type="checkbox"/> No		

A-97

HCM ANALYSIS REVIEW CHECKLIST *(continued)*

Wisconsin Department of Transportation (WisDOT) DT1887

<p>Traffic Volumes, % Trucks, Peak Hour Factor (PHF)</p>	<p><input checked="" type="checkbox"/> <input type="checkbox"/> <input type="checkbox"/> Conditionally Acceptable</p>	<p><input type="checkbox"/> <input type="checkbox"/> <input type="checkbox"/> Yes</p>	<p>PHF = 1 and PHF = 0.89 scenarios both reviewed</p> <p>In the 4-lane tab of the App A Excel spreadsheet, the terrain is noted as "rolling". Should this apply to those analyses using the 13% HVs also mentioned in the spreadsheet? The proposals are acceptable.</p>	<p>The excel spreadsheet has been updated to address the difference in terrain. The rolling terrain occurs further east of the proposed CTH G interchange so a "level" analysis is probably appropriate here. No changes to HCS files are proposed, please confirm.</p> <p>For truck percentages, the data has been broken down in weighted averages to be 17% from CTH UU to CTH G and 13% from CTH G to CTH P. The more conservative 17% value of the two weighted average truck percentages is used in this analysis. No changes are proposed, please confirm.</p>
--	---	---	--	---

(continued on reverse side)

SUMMARY OF REVIEW *(continued)*

Item Reviewed	Overall Model Acceptability	Revision Required	Reviewer Comment(s)	Analyst Response(s)
<p>A-98 Signal Parameters (including RTOR)</p>	<p><input type="checkbox"/> <input type="checkbox"/> <input type="checkbox"/> Acceptable <input type="checkbox"/> <input type="checkbox"/> <input type="checkbox"/> Unacceptable <input type="checkbox"/> <input type="checkbox"/> <input type="checkbox"/> Conditionally Acceptable <input type="checkbox"/> <input type="checkbox"/> <input checked="" type="checkbox"/> N/A</p>	<p><input checked="" type="checkbox"/> <input checked="" type="checkbox"/> <input type="checkbox"/> No <input type="checkbox"/> <input type="checkbox"/> <input type="checkbox"/> Yes</p>		
<p>Stop-Control/Roundabout Parameters</p>	<p><input type="checkbox"/> <input type="checkbox"/> <input type="checkbox"/> Acceptable <input type="checkbox"/> <input type="checkbox"/> <input type="checkbox"/> Unacceptable <input type="checkbox"/> <input type="checkbox"/> <input type="checkbox"/> Conditionally Acceptable <input type="checkbox"/> <input type="checkbox"/> <input checked="" type="checkbox"/> N/A</p>	<p><input checked="" type="checkbox"/> <input checked="" type="checkbox"/> <input type="checkbox"/> No <input type="checkbox"/> <input type="checkbox"/> <input type="checkbox"/> Yes</p>		
<p>Freeway/Highway Parameters</p>	<p><input type="checkbox"/> <input checked="" type="checkbox"/> <input type="checkbox"/> Acceptable <input type="checkbox"/> <input type="checkbox"/> <input type="checkbox"/> Unacceptable <input checked="" type="checkbox"/> <input type="checkbox"/> <input type="checkbox"/> Conditionally Acceptable <input type="checkbox"/> <input type="checkbox"/> <input type="checkbox"/> N/A</p>	<p><input checked="" type="checkbox"/> <input checked="" type="checkbox"/> <input type="checkbox"/> No <input type="checkbox"/> <input type="checkbox"/> <input type="checkbox"/> Yes</p>	<p>The FFS in the previous round of 4-lane files was 60 MPH. Now it is 70 MPH. Please confirm that the planned posted speed limit is now 65 MPH. Thank you.</p>	<p>Posted speed assumptions for the 4-Lane and Hybrid Alternatives were confirmed WisDOT NE Region staff on 3/28/2018. Hybrid Alternative posted = 55 mph (freeflow = 60 mph) 4-Lane Alternative posted = 65 mph (freeflow = 70 mph)</p>
<p>Measures of Effectiveness (MOEs)</p>	<p><input checked="" type="checkbox"/> <input checked="" type="checkbox"/> <input type="checkbox"/> Acceptable <input type="checkbox"/> <input type="checkbox"/> <input type="checkbox"/> Unacceptable <input type="checkbox"/> <input type="checkbox"/> <input type="checkbox"/> Conditionally Acceptable <input type="checkbox"/> <input type="checkbox"/> <input type="checkbox"/> N/A</p>	<p><input checked="" type="checkbox"/> <input checked="" type="checkbox"/> <input type="checkbox"/> No <input type="checkbox"/> <input type="checkbox"/> <input type="checkbox"/> Yes</p>		
<p>Other:</p>	<p><input type="checkbox"/> <input type="checkbox"/> <input type="checkbox"/> Acceptable <input type="checkbox"/> <input type="checkbox"/> <input type="checkbox"/> Unacceptable <input type="checkbox"/> <input type="checkbox"/> <input type="checkbox"/> Conditionally Acceptable</p>	<p><input type="checkbox"/> <input type="checkbox"/> <input type="checkbox"/> No <input type="checkbox"/> <input type="checkbox"/> <input type="checkbox"/> Yes</p>		
<p>Overall Model</p>	<p><input type="checkbox"/> <input checked="" type="checkbox"/> <input type="checkbox"/> Acceptable <input type="checkbox"/> <input type="checkbox"/> <input type="checkbox"/> Unacceptable</p>	<p><input checked="" type="checkbox"/> <input checked="" type="checkbox"/> <input type="checkbox"/> No</p>		



HCM ANALYSIS REVIEW CHECKLIST

Wisconsin Department of Transportation (WisDOT)

DT1887 8/2015

	<input checked="" type="checkbox"/> <input type="checkbox"/> <input type="checkbox"/> Conditionally Acceptable	<input type="checkbox"/> <input type="checkbox"/> <input type="checkbox"/> Yes	Could of things to look into and confirm. Overall, looking pretty good - LOS not a concern. The 4-lane models are acceptable.	JMU 4-12-2018: Please see discussion above related to truck percentages and confirm the modeling approach.
--	--	--	--	--



HCM ANALYSIS REVIEW CHECKLIST

Wisconsin Department of Transportation (WisDOT)
DT1887 8/2015

Project ID(s) 1440-13-00		Region: NE		Date Reviewed (m/d/yyyy)		
Project Name/Description WIS 23, Fond du Lac to Plymouth		Highway(s) WIS 23		1 st Review 4/11/2018	2 nd Review 4/12/2018	3 rd Review
Reviewed By: WisDOT BTO						
Lead Reviewer	Name (First, MI, Last) Ben Rouleau	Lead Analyst	Name (First, MI, Last) Joe Urban	Region Contact	Name (First, MI, Last) Bryan Lipke	
	Organization/Firm WisDOT BTO		Organization/Firm Strand Associates		Region/Bureau NE Region	
	(Area Code) Telephone Number (608) 266-7717		(Area Code) Telephone Number (608) 251-4843		(Area Code) Telephone Number (920) 492-5703	
	Email Address benjamin.rouleau@dot.wi.gov		Email Address joseph.urban@strand.com		Email Address bryan.lipke@dot.wi.gov	

TRAFFIC MODEL DESCRIPTION

Model Completion/Revision Date (m/d/yyyy) 11/2/2017	Analysis Year(s) 2040	Analysis Scenario/Alternative 4-Lane, Hybrid, No-Build, Passing Lane (w/ and w/o lefts), General Intersections
--	--------------------------	--

A-100

Scope of Model (intersections, ramps, corridors, etc. being reviewed)
WIS 23 from County UU (Fond du Lac) to County P (Sheboygan); CTH UU, CTH G, CTH W Loehr intersections

Analysis Time Period (s)

Weekday AM Peak
 Weekday Midday Peak
 Weekday PM Peak
 Fri Peak
 Sat Peak
 Sun Peak
 Other: K30

Hours: various
 Hours: _____
 Hours: various
 Hours: _____
 Hours: _____
 Hours: _____
 Hours: various

Analysis Tool(s) Utilized

HCS - Version: 7.5
 Synchro - Version/Build: _____
 Sidra - Version: _____
 Other: _____ - Version: _____

SUMMARY OF REVIEW

Item Reviewed	Overall Model Acceptability	Revision Required	Reviewer Comment(s)	Analyst Response(s)
Traffic Analysis Tool/Version	<input checked="" type="checkbox"/> <input checked="" type="checkbox"/> <input type="checkbox"/> Acceptable <input type="checkbox"/> <input type="checkbox"/> <input type="checkbox"/> Unacceptable <input type="checkbox"/> <input type="checkbox"/> <input type="checkbox"/> Conditionally Acceptable	<input checked="" type="checkbox"/> <input checked="" type="checkbox"/> <input type="checkbox"/> No <input type="checkbox"/> <input type="checkbox"/> <input type="checkbox"/> Yes		
Lane Geometry	<input checked="" type="checkbox"/> <input checked="" type="checkbox"/> <input type="checkbox"/> Acceptable <input type="checkbox"/> <input type="checkbox"/> <input type="checkbox"/> Unacceptable <input type="checkbox"/> <input type="checkbox"/> <input type="checkbox"/> Conditionally Acceptable	<input checked="" type="checkbox"/> <input checked="" type="checkbox"/> <input type="checkbox"/> No <input type="checkbox"/> <input type="checkbox"/> <input type="checkbox"/> Yes		
Traffic Volumes, % Trucks, Peak Hour Factor (PHF)	<input checked="" type="checkbox"/> <input checked="" type="checkbox"/> <input type="checkbox"/> Acceptable <input type="checkbox"/> <input type="checkbox"/> <input type="checkbox"/> Unacceptable <input type="checkbox"/> <input type="checkbox"/> <input type="checkbox"/> Conditionally Acceptable	<input checked="" type="checkbox"/> <input checked="" type="checkbox"/> <input type="checkbox"/> No <input type="checkbox"/> <input type="checkbox"/> <input type="checkbox"/> Yes		

HCM ANALYSIS REVIEW CHECKLIST *(continued)*

(continued on reverse side)

SUMMARY OF REVIEW <i>(continued)</i>				
Item Reviewed	Overall Model Acceptability	Revision Required	Reviewer Comment(s)	Analyst Response(s)
Signal Parameters (including RTOR)	<input type="checkbox"/> <input type="checkbox"/> <input type="checkbox"/> Acceptable <input type="checkbox"/> <input type="checkbox"/> <input type="checkbox"/> Unacceptable <input type="checkbox"/> <input type="checkbox"/> <input type="checkbox"/> Conditionally Acceptable <input type="checkbox"/> <input type="checkbox"/> <input checked="" type="checkbox"/> N/A	<input checked="" type="checkbox"/> <input checked="" type="checkbox"/> <input type="checkbox"/> No <input type="checkbox"/> <input type="checkbox"/> <input type="checkbox"/> Yes		
Stop-Control/Roundabout Parameters	<input type="checkbox"/> <input checked="" type="checkbox"/> <input type="checkbox"/> Acceptable <input type="checkbox"/> <input type="checkbox"/> <input type="checkbox"/> Unacceptable <input checked="" type="checkbox"/> <input type="checkbox"/> <input type="checkbox"/> Conditionally Acceptable <input type="checkbox"/> <input type="checkbox"/> <input type="checkbox"/> N/A	<input type="checkbox"/> <input checked="" type="checkbox"/> <input type="checkbox"/> No <input checked="" type="checkbox"/> <input type="checkbox"/> <input type="checkbox"/> Yes	<p>The base critical headway for the J-turn analyses is set to 4.3. Even though this value isn't used, it should be 4.4 (HCM6, 23-77). The changes are acceptable.</p>	<p>The base critical headway settings have been revised to 4.4 seconds for the U-turn movements at the crossover intersections. Strand confirmed that the control delay results remain the same.</p>
A-101 Freeway/Highway Parameters	<input type="checkbox"/> <input checked="" type="checkbox"/> <input type="checkbox"/> Acceptable <input type="checkbox"/> <input type="checkbox"/> <input type="checkbox"/> Unacceptable <input checked="" type="checkbox"/> <input type="checkbox"/> <input type="checkbox"/> Conditionally Acceptable <input type="checkbox"/> <input type="checkbox"/> <input type="checkbox"/> N/A	<input checked="" type="checkbox"/> <input checked="" type="checkbox"/> <input type="checkbox"/> No <input type="checkbox"/> <input type="checkbox"/> <input type="checkbox"/> Yes	<p>To confirm - the mainline through the J-turn will be posted at 65 MPH? This is set as the "Major Street Free-Flow Speed". The changes are acceptable.</p>	<p>In the 4-Lane Alternative the mainline would be posted at 65 mph (with a freeflow speed of 70 mph) and in the Hybrid Alternative the mainline would be posted at 55 mph (with a freeflow speed of 60 mph). These posted speeds were confirmed by WisDOT NE Region staff on 3/28/2018. - Upon further review, the Hybrid Alternative J-Turn analysis has been updated with the 60 mph free-flow speed (was previously set at 65 mph). Results have been updated. - With the 4-Lane Alternative, HCS does not allow a speed of 70 mph to be entered (software caps the speed at 65 mph). The HCS output could be post-processed to represent 70 mph, but the difference in travel time between the primary intersection and U-turns should be minimal. No changes to 4-Lane output based on 70 mph freeflow speed is proposed, please confirm.</p>
	<input type="checkbox"/> <input checked="" type="checkbox"/> <input type="checkbox"/> Acceptable <input type="checkbox"/> <input type="checkbox"/> <input type="checkbox"/> Unacceptable	<input checked="" type="checkbox"/> <input checked="" type="checkbox"/> <input type="checkbox"/> No		



HCM ANALYSIS REVIEW CHECKLIST

Wisconsin Department of Transportation (WisDOT)

DT1887 8/2015

<p>Measures of Effectiveness (MOEs)</p>	<p> <input checked="" type="checkbox"/> <input type="checkbox"/> <input type="checkbox"/> Conditionally Acceptable <input type="checkbox"/> <input type="checkbox"/> <input type="checkbox"/> N/A </p>	<p><input type="checkbox"/> <input type="checkbox"/> <input type="checkbox"/> Yes</p>	<p>For the J-turn analyses, recommend presenting results by movement. The changes are acceptable.</p>	<p>Results have been updated to show individual movements for the NBR + EB U-turn and the SBR + WB U-turn, along with the NB and SB approaches. The mainline left-turn movements are shown in the tables above. Please see revised MOE table provided with this review.</p>
<p>Other:</p>	<p> <input type="checkbox"/> <input type="checkbox"/> <input type="checkbox"/> Acceptable <input type="checkbox"/> <input type="checkbox"/> <input type="checkbox"/> Unacceptable <input type="checkbox"/> <input type="checkbox"/> <input type="checkbox"/> Conditionally Acceptable </p>	<p> <input type="checkbox"/> <input type="checkbox"/> <input type="checkbox"/> No <input type="checkbox"/> <input type="checkbox"/> <input type="checkbox"/> Yes </p>		
<p>Overall Model</p>	<p> <input type="checkbox"/> <input checked="" type="checkbox"/> <input type="checkbox"/> Acceptable <input type="checkbox"/> <input type="checkbox"/> <input type="checkbox"/> Unacceptable <input checked="" type="checkbox"/> <input type="checkbox"/> <input type="checkbox"/> Conditionally Acceptable </p>	<p> <input checked="" type="checkbox"/> <input checked="" type="checkbox"/> <input type="checkbox"/> No <input type="checkbox"/> <input type="checkbox"/> <input type="checkbox"/> Yes </p>	<p>Some things to check into on the J-Turn analyses. Otherwise, looking good. The intersection models are acceptable.</p>	<p>JMU 4-12-2018: A few revisions have been made per the responses above.</p>

**ATTACHMENT H
TRAFFIC OPERATIONS RESULTS**

		County UU to County G									
		2-Lane No Build		Passing Lane Alternatives						4-Lane On-Alignment	
				Passing Lanes Without Left Turn Lanes		Passing Lanes With Left Turn Lanes		Hybrid			
		Eastbound	Westbound	Eastbound	Westbound	Eastbound	Westbound	Eastbound*	Westbound*	Eastbound*	Westbound*
File Peak Hour Pattern	HCS Average Speed (mph) 2017	47.8	47.7	--	--	--	--	--	--	--	--
	% Following 2017	67.5%	67.7%	--	--	--	--	--	--	--	--
	LOS 2017 (Numeric)	4.17	4.18	--	--	--	--	--	--	--	--
	LOS 2017	D	D	--	--	--	--	--	--	--	--
	HCS Average Speed (mph) 2040	48.0	47.9	48.8	48.8	48.4	48.4	60.0	60.0	70.0	70.0
	% Following 2040	66.3%	66.6%	53.1%	52.8%	54.8%	54.3%	--	--	--	--
	LOS 2040 (Numeric)	4.09	4.11	3.21	3.19	3.32	3.29	--	--	--	--
	LOS 2040	D	D	C	C	C	C	A	A	A	A
	Year LOS passes from C to D	2017	2017	2060+	2060+	2060+	2060+	--	--	--	--
	First Year C to D (either direction)	2017		2060+		2060+		--		--	

*4-Lane Freeway Analysis

Existing Peak Hour Pattern	HCS Average Speed (mph) 2040	47.5	47.4	48.2	48.2	47.8	47.9	60.0	60.0	70.0	70.0
	% Following 2040	69.3%	69.6%	56.5%	56.1%	58.1%	57.5%	--	--	--	--
	LOS 2040 (Numeric)	4.29	4.31	3.43	3.41	3.54	3.50	--	--	--	--
	LOS 2040	D	D	C	C	C	C	A	A	A	A
	Year LOS passes from C to D	2017	2017	2060+	2060+	2060+	2060+	--	--	--	--
	First Year C to D (either direction)	2017		2060+		2060+		--		--	

*4-Lane Freeway Analysis

A-104

		County G to County P									
		2-Lane No Build		Passing Lane Alternatives						4-Lane On-Alignment	
				Passing Lanes Without Left Turn Lanes		Passing Lanes With Left Turn Lanes		Hybrid			
		Eastbound	Westbound	Eastbound	Westbound	Eastbound	Westbound	Eastbound	Westbound	Eastbound*	Westbound*
File Peak Hour Pattern	HCS Average Speed (mph) 2017	48.4	48.8	--	--	--	--	--	--	--	--
	% Following 2017	64.2%	66.3%	--	--	--	--	--	--	--	--
	LOS 2017 (Numeric)	3.95	4.09	--	--	--	--	--	--	--	--
	LOS 2017	C	D	--	--	--	--	--	--	--	--
	HCS Average Speed (mph) 2040	48.8	49.2	48.9	50.1	48.4	49.5	48.0	49.4	70.0	70.0
	% Following 2040	62.0%	64.9%	62.0%	52.6%	64.2%	54.7%	65.7%	55.7%	--	--
	LOS 2040 (Numeric)	3.80	3.99	3.80	3.17	3.95	3.31	4.05	3.38	--	--
	LOS 2040	C	C	C	C	C	C	D	C	A	A
	Year LOS passes from C to D	2060+	2017	2060+	2060+	2060+	2060+	2039	2060+	--	--
	First Year C to D (either direction)	2017		2060+		2060+		2039		--	

*4-Lane Freeway Analysis

Existing Peak Hour Pattern	HCS Average Speed (mph) 2040	48.3	48.7	48.4	49.5	47.9	49.0	47.4	48.9	70.0	70.0
	% Following 2040	64.7%	66.4%	63.7%	54.0%	65.8%	55.9%	67.6%	58.9%	--	--
	LOS 2040 (Numeric)	3.98	4.09	3.91	3.27	4.05	3.39	4.17	3.59	--	--
	LOS 2040	C	D	C	C	D	C	D	C	A	A
	Year LOS passes from C to D	2054	2017	2060+	2060+	2025	2060+	2020	2060+	--	--
	First Year C to D (either direction)	2017		2060+		2025		2020		--	

*4-Lane Freeway Analysis

Alpha and Numeric Level of Service (LOS) Scale

LOS	A	B	C	D	E	F
% Following	≤ 35%	35 - 50%	50 - 65%	65 - 80%	> 80%	volume/capacity > 1.0
Numeric LOS	1.01 - 2.00	2.01 - 3.00	3.01 - 4.00	4.01 - 5.00	5.01 - 6.00	6.01+
Average Travel Speed (mph)	> 55	> 50 - 55	> 45 - 50	> 40 - 45	≤ 40	volume/capacity > 1.0

Note: Results are based on WisDOT traffic forecasts completed on April 6, 2018 (Appendix A, NERTDM only) using Highway Capacity Software (HCS) Version 7. See "DHV for WIS 23 Evaluation" memo and "Traffic Modeling Methodology" memo for more information on analysis inputs and assumptions. See "WIS 23 Travel Time Estimation" tables in this appendix for further speed and travel time analysis.

County UU to County G										
Distance (mi) 9.8										
	2-Lane No Build		Passing Lane Alternatives						4-Lane On-Alignment	
			Passing Lanes Without Left Turn Lanes		Passing Lanes With Left Turn Lanes		Hybrid			
	Eastbound	Westbound	Eastbound	Westbound	Eastbound	Westbound	Eastbound*	Westbound*	Eastbound*	Westbound*
HCS Average Speed (mph) 2017	47.8	47.7	--	--	--	--	--	--	--	--
Observed Travel Speed (mph) 2017	58.0	58.0	--	--	--	--	--	--	--	--
Average Travel Time (s) 2017	608	608	--	--	--	--	--	--	--	--
HCS Average Speed (mph) 2040	48.0	47.9	48.8	48.8	48.4	48.4	60.0	60.0	70.0	70.0
Adjusted Travel Speed (mph) 2040	58.2	58.2	59.0	59.1	58.6	58.7	60.0	60.0	70.0	70.0
Average Travel Time (s) 2040	606	606	598	597	602	601	588	588	504	504

*4-Lane Freeway Analysis

County G to County P										
Distance (mi) 8.0										
	2-Lane No Build		Passing Lane Alternatives						4-Lane On-Alignment	
			Passing Lanes Without Left Turn Lanes		Passing Lanes With Left Turn Lanes		Hybrid			
	Eastbound	Westbound	Eastbound	Westbound	Eastbound	Westbound	Eastbound	Westbound	Eastbound*	Westbound*
HCS Average Speed (mph) 2017	48.4	48.8	--	--	--	--	--	--	--	--
Observed Travel Speed (mph) 2017	58.0	58.0	--	--	--	--	--	--	--	--
Average Travel Time (s) 2017	497	497	--	--	--	--	--	--	--	--
HCS Average Speed (mph) 2040	48.8	49.2	48.9	50.1	48.4	49.5	48.0	49.4	70.0	70.0
Adjusted Travel Speed (mph) 2040	58.4	58.4	58.5	59.3	58.0	58.7	57.6	58.6	70.0	70.0
Average Travel Time (s) 2040	493	493	492	486	497	491	500	491	411	411

*4-Lane Freeway Analysis

Travel Time Differences (s) County UU to County G					
Eastbound (Flat Peak Hour Pattern)					
2017	No-Build	PL no L	PL w L	Hybrid	4-Lane
608	606	598	602	588	504
Diff vs 2017	-2	-10	-6	-20	-104
Diff vs 2040 No-Build	-8	-4	-18	-102	

Westbound (Flat Peak Hour Pattern)					
2017	No-Build	PL no L	PL w L	Hybrid	4-Lane
608	606	597	601	588	504
Diff vs 2017	-2	-11	-7	-20	-104
Diff vs 2040 No-Build	-9	-5	-18	-102	

Travel Time Differences (s) County G to County P					
Eastbound (Flat Peak Hour Pattern)					
2017	No-Build	PL no L	PL w L	Hybrid	4-Lane
497	493	492	497	500	411
Diff vs 2017	-3	-4	0	3	-85
Diff vs 2040 No-Build	-1	3	7	-82	

Westbound (Flat Peak Hour Pattern)					
2017	No-Build	PL no L	PL w L	Hybrid	4-Lane
497	493	486	491	491	411
Diff vs 2017	-3	-11	-6	-5	-85
Diff vs 2040 No-Build	-7	-3	-2	-82	

A-105

Notes:

#	Description:
1	Observed speeds are based on National Performance Management Research Data Set (NPMRDS) data from June 27-29, 2017 (3 weekdays), coinciding with the week of traffic volume counts for the study.
2	Highway Capacity Software (HCS) results are based on WisDOT traffic forecasts completed on April 6, 2018 (Appendix A) using HCS Version 7.
3	See "DHV for WIS 23 Evaluation" memo and "Traffic Modeling Methodology" memo for more information on HCS analysis inputs and assumptions.
4	4-Lane section freeflow speed assumed to be 5 mph above expected posted speeds. Modeling confirms no reduction in freeflow speed for 4-lane sections.
5	Adjusted travel speeds for the 2-lane sections of the 2040 No-Build and Build Alternatives are developed by using the relative difference predicted by HCS and applying it to the 2017 observed speed data. For example, if a segment's 2040 alternative travel speed is predicted to be 1 mph faster than the segment's 2017 existing condition travel speed in HCS, the segment's adjusted travel speed for the 2040 alternative = 58 mph (Observed Speed) + 1 mph (Difference Predicted by HCS) = 59 mph (Adjusted Travel Speed). See Page 2 for all HCS difference calculations.

Travel Time Summary (s) vs. 2040 No-Build				
Direction	PL no L	PL w L	Hybrid	4-Lane
WB	17	8	20	184
EB	9	1	11	184
Average	13	4	16	184
Travel Time Savings	10-15s	0-10s	10-20s	3 min 5s

Travel time savings rounded to nearest 5s

	County UU to County G										Notes and Assumptions	
	2-Lane No Build		Passing Lane Alternatives						4-Lane On-Alignment			
			Passing Lanes Without Left Turn Lanes		Passing Lanes With Left Turn Lanes		Hybrid					
	Eastbound	Westbound	Eastbound	Westbound	Eastbound	Westbound	Eastbound*	Westbound*	Eastbound*	Westbound*		
HCS Average Speed (mph) 2017	47.8	47.7	--	--	--	--	--	--	--	--	--	Modeled 2017 existing conditions HCS travel speed
Observed Travel Speed (mph) 2017	58.0	58.0	--	--	--	--	--	--	--	--	--	
HCS Average Speed (mph) 2040	48.0	47.9	48.8	48.8	48.4	48.4	60.0	60.0	70.0	70.0		Modeled 2040 HCS travel speed
HCS DIFFERENCE (2040 - 2017)	0.2	0.2	1.0	1.1	0.6	0.7	--	--	--	--		Difference between 2040 HCS travel speed and 2017 HCS travel speed
Adjusted Travel Speed (mph) 2040	58.2	58.2	59.0	59.1	58.6	58.7	60.0	60.0	70.0	70.0		

*4-Lane Freeway Analysis

	County G to County P										Notes and Assumptions	
	2-Lane No Build		Passing Lane Alternatives						4-Lane On-Alignment			
			Passing Lanes Without Left Turn Lanes		Passing Lanes With Left Turn Lanes		Hybrid					
	Eastbound	Westbound	Eastbound	Westbound	Eastbound	Westbound	Eastbound	Westbound	Eastbound*	Westbound*		
HCS Average Speed (mph) 2017	48.4	48.8	--	--	--	--	--	--	--	--	--	Modeled 2017 existing conditions HCS travel speed
Observed Travel Speed (mph) 2017	58.0	58.0	--	--	--	--	--	--	--	--	--	
HCS Average Speed (mph) 2040	48.8	49.2	48.9	50.1	48.4	49.5	48.0	49.4	70.0	70.0		Modeled 2040 HCS travel speed
HCS DIFFERENCE (2040 - 2017)	0.4	0.4	0.5	1.3	0.0	0.7	-0.4	0.6	--	--		Difference between 2040 HCS travel speed and 2017 HCS travel speed
Adjusted Travel Speed (mph) 2040	58.4	58.4	58.5	59.3	58.0	58.7	57.6	58.6	70.0	70.0		

*4-Lane Freeway Analysis

A-101

Notes:

#	Description:
1	Observed speeds are based on National Performance Management Research Data Set (NPMRDS) data from June 27-29, 2017 (3 weekdays), coinciding with the week of traffic volume counts for the study.
2	Highway Capacity Software (HCS) results are based on WisDOT traffic forecasts completed on April 6, 2018 (Appendix A) using HCS Version 7.
3	See "DHV for WIS 23 Evaluation" memo and "Traffic Modeling Methodology" memo for more information on HCS analysis inputs and assumptions.
4	4-Lane section freeflow speed assumed to be 5 mph above expected posted speeds. Modeling confirms no reduction in freeflow speed for 4-lane sections.
5	Adjusted travel speeds for the 2-lane sections of the 2040 No-Build and Build Alternatives are developed by using the relative difference predicted by HCS and applying it to the 2017 observed speed data. For example, if a segment's 2040 alternative travel speed is predicted to be 1 mph faster than the segment's 2017 existing condition travel speed in HCS, the segment's adjusted travel speed for the 2040 alternative = 58 mph (Observed Speed) + 1 mph (Difference Predicted by HCS) = 59 mph (Adjusted Travel Speed).

No Build Side Street LOS																
Intersection	2040 AM PEAK								2040 PM PEAK							
	NBL/TH		NBR		SBL/TH		SBR		NBL/TH		NBR		SBL/TH		SBR	
	Delay (s)	LOS	Delay (s)	LOS	Delay (s)	LOS	Delay (s)	LOS	Delay (s)	LOS	Delay (s)	LOS	Delay (s)	LOS	Delay (s)	LOS
County UU	24.5	C	10.4	B	22.1	C	12.4	B	39.1	E	12.7	B	27.9	D	11.6	B
County W/Loehr	16.7	C	10.1	B	17.2	C	10.7	B	20.5	C	10.9	B	21.3	C	10.8	B
County G	17.6	C	10.4	B	16.9	C	10.3	B	22.0	C	10.6	B	20.6	C	10.5	B

Passing Lane Alternative without Left-Turn Lanes																
Intersection	2040 AM PEAK								2040 PM PEAK							
	NBL/TH		NBR		SBL/TH		SBR		NBL/TH		NBR		SBL/TH		SBR	
	Delay (s)	LOS	Delay (s)	LOS	Delay (s)	LOS	Delay (s)	LOS	Delay (s)	LOS	Delay (s)	LOS	Delay (s)	LOS	Delay (s)	LOS
County UU	25.4	D	10.4	B	22.7	C	12.6	B	41.8	E	12.8	B	29.0	D	11.7	B
County W/Loehr	17.0	C	10.1	B	17.7	C	10.7	B	21.1	C	11.0	B	22.1	C	10.9	B
County G	18.1	C	10.5	B	17.3	C	10.4	B	22.9	C	10.7	B	21.3	C	10.6	B

Passing Lane Alternative with Left-Turn Lanes																
Intersection	2040 AM PEAK								2040 PM PEAK							
	NBL/TH		NBR		SBL/TH		SBR		NBL/TH		NBR		SBL/TH		SBR	
	Delay (s)	LOS	Delay (s)	LOS	Delay (s)	LOS	Delay (s)	LOS	Delay (s)	LOS	Delay (s)	LOS	Delay (s)	LOS	Delay (s)	LOS
County UU	17.3	C	10.4	B	16.0	C	12.6	B	21.2	C	12.8	B	18.5	C	11.7	B
County W/Loehr	13.8	B	10.1	B	14.1	B	10.7	B	16.0	C	11.0	B	15.9	C	10.9	B
County G	14.5	B	10.5	B	14.1	B	10.4	B	16.4	C	10.7	B	15.8	C	10.6	B

NBL = Northbound Left, NBR = Northbound Right
 SBL = Southbound Left, SBR = Southbound Right
 TH = Through, LOS = Level of Service

Notes: No-Build operations are based on April 6, 2018 traffic forecasts (App. A of traffic forecasting memo, NERTDM only). Passing Lane operations are based on volumes factored up from No-Build forecast. See Traffic Modeling Methodology Memo attachments for more detail on the inputs used for the intersection operations analysis.

A-107

Intersection	Alternative	Hybrid and 4-Lane Alternatives: County UU															
		2040 AM PEAK								2040 PM PEAK							
		EB Approach		WB Approach		NB Approach		SB Approach		EB Approach		WB Approach		NB Approach		SB Approach	
		Delay (s)	LOS	Delay (s)	LOS	Delay (s)	LOS	Delay (s)	LOS	Delay (s)	LOS	Delay (s)	LOS	Delay (s)	LOS	Delay (s)	LOS
County UU WB Ramp Terminal Roundabout	Hybrid	---	---	3.2	A	3.4	A	3.2	A	---	---	3.5	A	4.1	A	3.8	A
	4-Lane	---	---	3.2	A	3.4	A	3.3	A	---	---	3.5	A	4.1	A	3.9	A
County UU EB Ramp Terminal Roundabout	Hybrid	3.5	A	---	---	3.4	A	3.1	A	3.4	A	---	---	4.2	A	3.7	A
	4-Lane	3.5	A	---	---	3.4	A	3.1	A	3.4	A	---	---	4.3	A	3.8	A

Intersection	Alternative	Hybrid and 4-Lane Alternatives: County G															
		2040 AM PEAK								2040 PM PEAK							
		EB Approach		WB Approach		NB Approach		SB Approach		EB Approach		WB Approach		NB Approach		SB Approach	
		Delay (s)	LOS	Delay (s)	LOS	Delay (s)	LOS	Delay (s)	LOS	Delay (s)	LOS	Delay (s)	LOS	Delay (s)	LOS	Delay (s)	LOS
County G WB Ramp Terminal Roundabout	Hybrid	---	---	3.5	A	3.7	A	3.4	A	---	---	3.5	A	3.8	A	3.6	A
	4-Lane	---	---	3.5	A	3.7	A	3.5	A	---	---	3.5	A	3.9	A	3.7	A
County G EB Ramp Terminal Roundabout	Hybrid	3.7	A	---	---	3.6	A	3.1	A	3.7	A	---	---	3.8	A	3.4	A
	4-Lane	3.7	A	---	---	3.7	A	3.2	A	3.8	A	---	---	3.9	A	3.5	A

Intersection	Alternative	Hybrid and 4-Lane Alternatives: County W/Loehr Road J-Turn (Primary Intersection Control Delay)															
		2040 AM PEAK								2040 PM PEAK							
		EBL		WBL		NBR		SBR		EBL		WBL		NBR		SBR	
		Delay (s)	LOS	Delay (s)	LOS	Delay (s)	LOS	Delay (s)	LOS	Delay (s)	LOS	Delay (s)	LOS	Delay (s)	LOS	Delay (s)	LOS
County W/Loehr Middle Intersection	Hybrid	8.8	A	0.0	A	9.8	A	10.4	B	8.9	A	0.0	A	10.1	B	10.6	B
	4-Lane	9.0	A	0.0	A	10.0	A	10.7	B	9.2	A	0.0	A	10.3	B	11.0	B

Intersection	Alternative	Hybrid and 4-Lane Alternatives: County W/Loehr Road J-Turn (Crossover Intersection Control Delay)															
		2040 AM PEAK								2040 PM PEAK							
		EBT		WB to EB U-turn		WBT		EB to WB U-turn		EBT		WB to EB U-turn		WBT		EB to WB U-turn	
		Delay (s)	LOS	Delay (s)	LOS	Delay (s)	LOS	Delay (s)	LOS	Delay (s)	LOS	Delay (s)	LOS	Delay (s)	LOS	Delay (s)	LOS
County W/Loehr West Crossover	Hybrid	0.0	A	9.5	A	---	---	---	---	0.0	A	10.4	B	---	---	---	---
	4-Lane	0.0	A	9.7	A	---	---	---	---	0.0	A	10.8	B	---	---	---	---
County W/Loehr East Crossover	Hybrid	---	---	---	---	0.0	A	9.2	A	---	---	---	---	0.0	A	9.9	A
	4-Lane	---	---	---	---	0.0	A	9.4	A	---	---	---	---	0.0	A	10.2	B

Intersection	Alternative	Hybrid and 4-Lane Alternatives: County W/Loehr Road J-Turn (HCM6 Alternative Intersection Analysis Results)															
		2040 AM PEAK								2040 PM PEAK							
		NBR + EB U-turn		SBR + WB U-turn		NB Approach		SB Approach		NBR + EB U-turn		SBR + WB U-turn		NB Approach		SB Approach	
		ETT (s)	LOS	ETT (s)	LOS	ETT (s)	LOS	ETT (s)	LOS	ETT (s)	LOS	ETT (s)	LOS	ETT (s)	LOS	ETT (s)	LOS
County W/Loehr Middle Intersection	Hybrid	45.1	D	49.4	D	36.0	D	20.9	C	46.1	D	50.5	D	36.8	D	23.5	C
	4-Lane	43.5	D	47.7	D	34.6	C	20.6	C	44.7	D	49.0	D	35.9	D	23.1	C

LOS = Level of Service, ETT = Experienced Travel Time, EB = Eastbound, WB = Westbound, NB = Northbound, SB = Southbound

Notes: 4-Lane Alternative operations are based on April 6, 2018 traffic forecasts (App. A of traffic forecasting memo, NERTDM only). Hybrid Alternative operations are based on volumes factored down from 4-Lane Alternative forecast. The LOS scale for Alternative Intersections is different from unsignalized intersections and is based on Exhibit 23-13 of the HCM6. See Traffic Modeling Methodology Memo attachments for more detail on the inputs used for the intersection operations analysis.