

TRANS. & LONGIT. SLAB BAR REINFORCEMENT TO BE CUT A MAX. OF 1" CL. FROM DRAIN FRAME. DISPLACE BARS WHERE POSSIBLE.

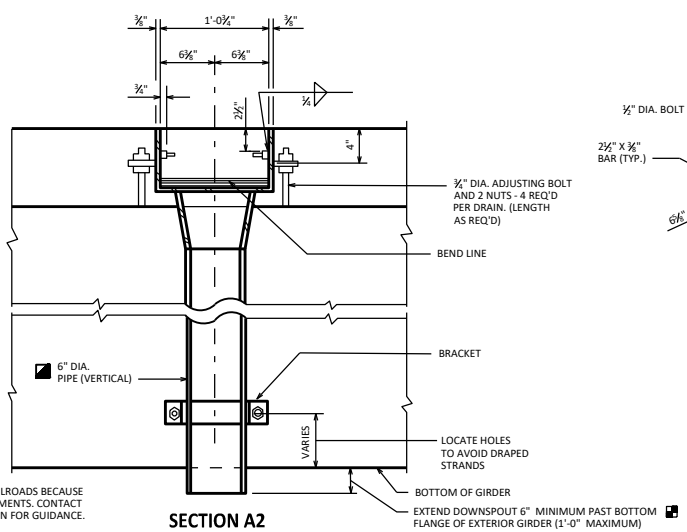

DETAIL NOT TO BE USED OVER RAILROADS BECAUSE IT VIOLATES CLEARANCE REQUIREMENTS. CONTACT RAILROADS AND HARBORS SECTION FOR GUIDANCE.

BRACKET DETAIL

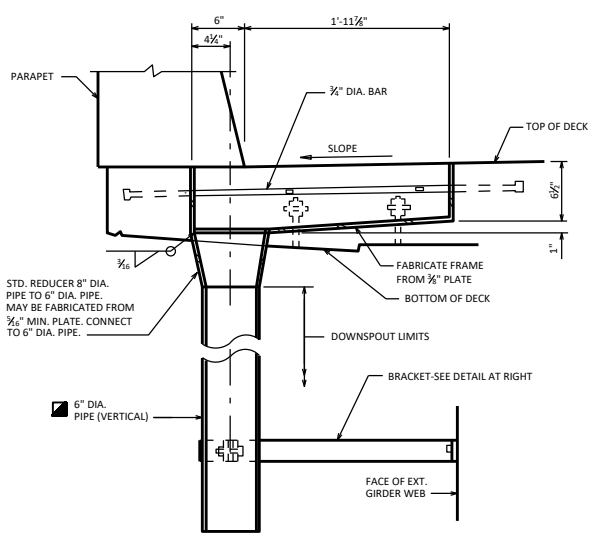
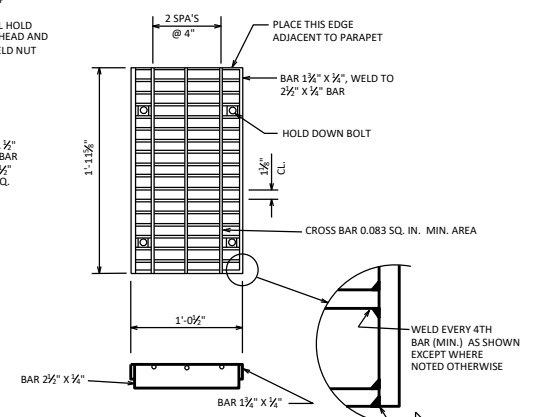
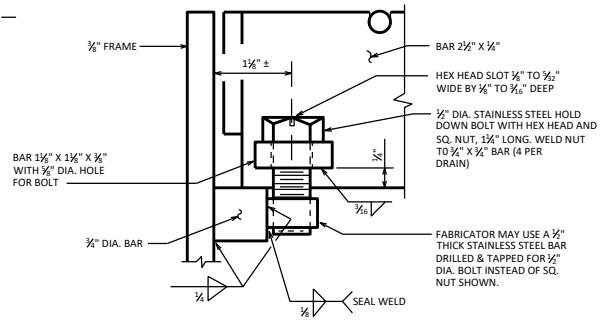
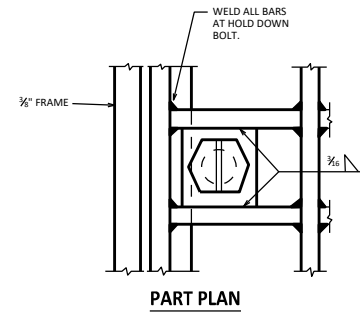
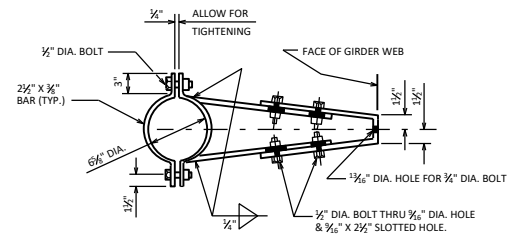

FLOOR DRAIN TYPE 'H'

BUREAU OF STRUCTURES

APPROVED: *Laura Shadewald*

DATE: 1-20

NOTES

- ALL DRAIN MATERIAL INCLUDING GRATE, EXCLUDING PIPE & GRATE HOLD DOWN BOLTS, SHALL BE ASTM A36 STEEL.
- MATERIAL FOR BRACKETS SHALL CONFORM TO ASTM A36.
- ALTERNATE BRACKETS ARE NOT ALLOWED.
- ALL STEEL SHALL BE GALVANIZED. WELDS SHALL BE MADE WITH LOW HYDROGEN ELECTRODES.
- ALL MATERIAL FOR FLOOR DRAINS TO BE INCLUDED IN THE BID ITEM "FLOOR DRAINS TYPE H".
- ALL MATERIAL FOR DOWNSPOUTS, DOWNSPOUT CONNECTIONS, AND BRACKETS TO BE INCLUDED IN THE BID ITEM "DOWNSPOUT 6-INCH".
- SEAL WELD INSIDE OF DRAIN.
- PRIOR TO GALVANIZING A NO. 6 BLAST CLEANING IS REQ'D.
- FLANGED 6" DIA. DOWNSPOUTS SHALL BE REINFORCED THERMOSETTING RESIN PIPE (TRP) OR GALVANIZED STANDARD PIPE CONFORMING TO ASTM A53.

DESIGNER NOTE

ON THE PRESTRESSED GIRDER SHEET, SHOW LOCATION OF HOLES FOR BRACKET ANCHORAGE FROM TOP/BOTTOM AND END OF GIRDER.