

DESIGNER NOTES

DIMENSIONS SHOWN APPLY TO CUT OR FILL SITUATIONS.

DECK DRAINS OR DOWN SPOUTS SHALL NOT DISCHARGE ONTO RAILROAD TRACK BED.

SINGLE SLOPE PARAPET SHALL BE USED. PEDESTRIAN RAILING WILL ONLY BE PROVIDED IF THERE IS A SIDEWALK. SEE CHAPTER 38 OF THE BRIDGE MANUAL.

- △ VERTICAL CLEARANCE MUST BE AT LEAST 23'-0" AFTER CONSTRUCTION. USE A STRAIGHT-LINE INTERPOLATION BETWEEN TOP OF BEARINGS TO DETERMINE THE CLEARANCE, PROVIDED THAT POSITIVE CAMBER IS REALIZED. LL DEFLECTION NEED NOT BE CONSIDERED WITH THE STRAIGHT-LINE APPROACH. DESIGN FOR (APPROX.) 23'-2" TO AVOID GOING BELOW THE MINIMUM DURING CONSTRUCTION. MAXIMUM ALLOWABLE VERTICAL CLEARANCE OF 23'-3/4" IS ALLOWED BY FHWA. VERTICAL CLEARANCE LESS THAN 23'-0" MAY BE PROVIDED IN SOME SITUATIONS WITH APPROVAL OF THE OFFICE OF THE COMMISSIONER OF RAILROADS. CONSULT WITH CENTRAL OFFICE RAILROAD UNIT.

** VARIABLE DISTANCE WHICH IS FOUND FROM FIELD SURVEY.

* SITE SPECIFIC JUSTIFICATION REQUIRED FOR GREATER DISTANCES. LATERAL CLEARANCES SHALL BE ESTABLISHED BASED ON SITE SPECIFIC CONDITIONS AND ECONOMICAL STRUCTURE DESIGN; CONSULT WITH CENTRAL OFFICE RAILROAD UNIT. SEE 23 CODE OF FEDERAL REGULATIONS PT 646, SUBPT. B APPENDIX.

▲ FOR OFFSETS UP TO, AND INCLUDING 25'-0", A CRASH WALL OR HAMMERHEAD PIER DESIGNED TO AREMA STANDARDS (30 SQ. FT. MIN. X-SECT) IS REQUIRED. CP RAIL REQUIRES CRASH WALLS BE DESIGNED TO RESIST A 600 KIP EXTREME EVENT FORCE APPLIED 6 FEET ABOVE THE GROUND. THE CRASH WALLS SHOWN ON THIS STANDARD ARE NOT DESIGNED TO ACCOUNT FOR THIS LOAD.

▲ ACCOMMODATION FOR ADDITIONAL TRACKS REQUIRES DEPARTMENT APPROVAL. CONFER WITH STATEWIDE RAILROAD STRUCTURE AND TRACK ENGINEER IN CENTRAL OFFICE RAILROADS AND HARBORS SECTION AT (608) 266-0233.

▲ HORIZONTAL CLEARANCES LESS THAN 18'-0" SHOULD BE REVIEWED WITH THE STATEWIDE RAILROAD AND TRACK ENGINEER IN THE CENTRAL OFFICE RAILROADS AND HARBORS SECTION. 18'-0" CLEARANCE IS MEASURED TO THE NEAREST ENCRACING ELEMENT (PIER CAPS, MSE WALL COPING, ETC.)

TEMPORARY CONSTRUCTION CLEARANCES ARE 21'-6" VERTICAL (21'-6" FOR BNSF AND UP RAILROADS) AND 12'-0" HORIZONTAL (15'-0" FOR BNSF AND UP RAILROADS) FROM CENTERLINE OF TRACK TO FALSEWORK. UNLESS INSTRUCTED OTHERWISE, A CONSTRUCTION CLEARANCE DETAIL SHOULD NOT BE INCLUDED IN THE PLANS AS CONSTRUCTION CLEARANCES ARE STATED IN SECTION 107.17.1 OF THE STANDARD SPECIFICATIONS.

DESIGNER SHALL SHOW HORIZONTAL LOCATION OF SHORING NEEDED IN PLAN VIEW. INCLUDE BID ITEM "TEMPORARY SHORING RAILROAD" WHEN SHORING ENCRACHES ZONE A OR B.

☆ 6'-6" MIN. NOT REQ'D IF BEDROCK IS PRESENT.

THIS STANDARD IS TO MEET WISDOT REQUIREMENTS ONLY. THE DESIGN ENGINEER SHALL CONTACT THE RAILROAD FOR THEIR REQUIREMENTS.

■ BNSF AND UP RAILROADS HAVE GREATER REQUIREMENTS THAN SHOWN. CONFER WITH STATEWIDE RAILROAD STRUCTURE AND TRACK ENGINEER IN CENTRAL OFFICE RAILROADS AND HARBORS SECTION. DESIGNER SHOULD CONSIDER FIELD TOLERANCES AND CONTINGENCIES WHEN SHOWING SHORING REQUIREMENTS. REFER TO "GUIDELINES FOR TEMPORARY SHORING" PUBLICATION BY UP AND BNSF FOR ADDITIONAL INFORMATION.

● BNSF AND UP RAILROAD REQUIRE A DEPTH OF FOOTING 6'-0" MIN. FROM BASE OF RAIL TO TOP OF FOOTING. IN LOCATIONS WHERE BEDROCK IS PRESENT, COORDINATE FOOTING DEPTHS WITH RAILROAD PROJECT COORDINATION ENGINEER.

● LIMITS OF RAILROAD RIGHT-OF-WAY. LOCATIONS SHOWN ARE FOR REFERENCE ONLY AND NEED NOT BE DIMENSIONED.

■ AESTHETICS SHALL NOT BE EMPLOYED ALONG RAILROAD TRACKS.

NOTES

FINAL LOCATION AND TYPE OF SHORING SYSTEM TO BE DETERMINED BY THE CONTRACTOR. THE CONTRACTOR SHALL SUBMIT ALL DESIGN DRAWINGS AND CALCULATIONS DIRECTLY TO THE RAILROAD. SHORING COVERED BY BID ITEM "TEMPORARY SHORING RAILROAD".

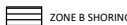
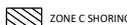
-  ZONE A SHORING
-  ZONE B SHORING
-  ZONE C SHORING

HIGHWAY OVER RAILROAD DESIGN REQUIREMENTS



BUREAU OF
STRUCTURES

APPROVED: *Laura Shadewald*

DATE:
7-17

STANDARD 38.01

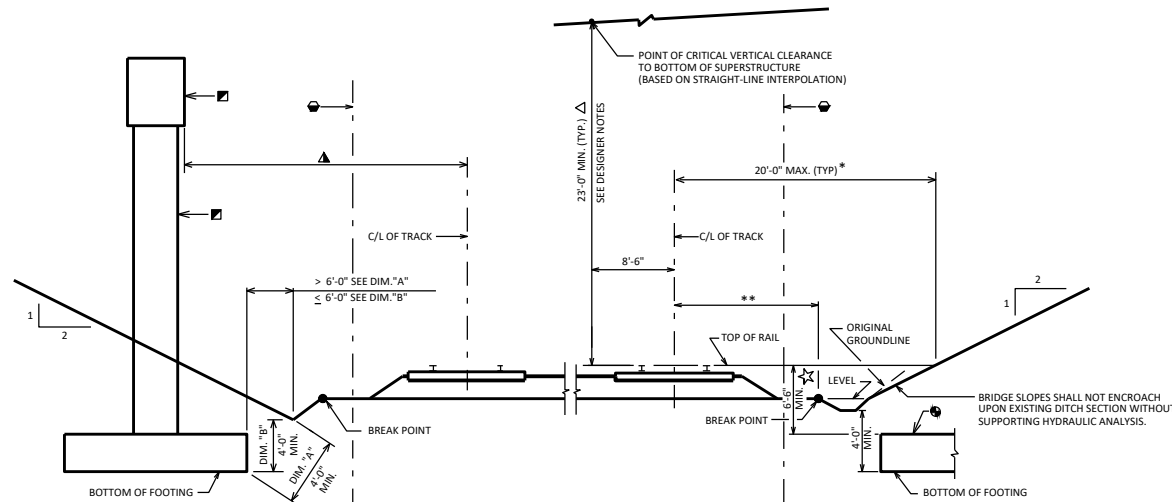

RAILROAD IN FILL

RAILROAD CROSS SECTIONS

RAILROAD IN CUT

	PIER LOCATION	HEIGHT OF CRASH WALL ABOVE TOP OF RAIL
GENERAL AREMA REQUIREMENT	PIERS < 12'-0" FROM C/L TRACK	12'-0"
	PIERS 12'-0" TO 25'-0"	6'-0"
CP RAIL REQUIREMENT	PIERS < 15'-0" FROM C/L TRACK	12'-0"
	PIERS ≥ 15'-0" TO 25'-0"	8'-0"

TABLE C

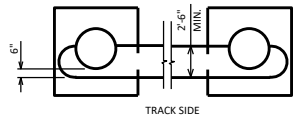

SECTION C-C

TRACK ON ONE SIDE OF COLUMNS

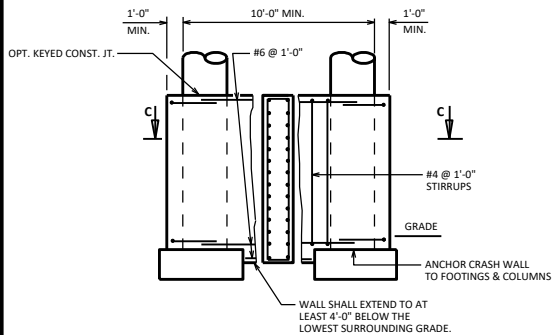

ELEVATION

CRASH WALL DETAILS

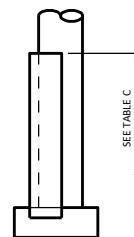

END VIEW

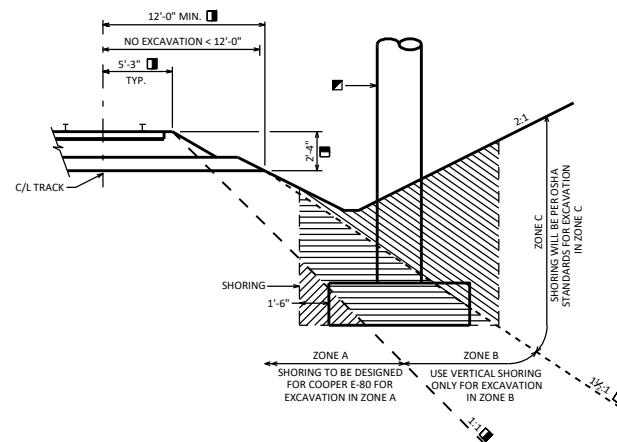

LIMITS BEFORE SHORING REQUIRED