

TOP PLATE "A"

LUBRICATED BRONZE PLATE "B"

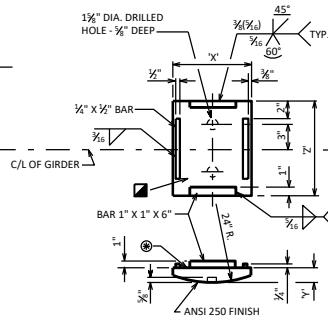

ROCKER PLATE "C"

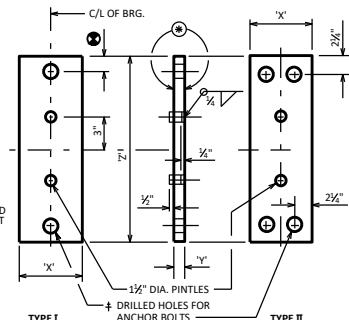

MASONRY PLATE "D"

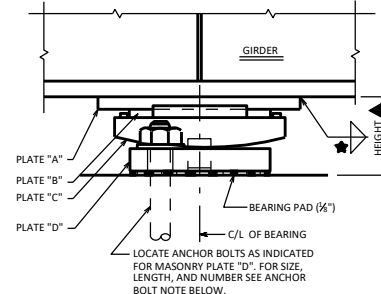

EXPANSION BEARING ASSEMBLY

NOTES

FOR BEARING NOTES, CLEARANCE DIAGRAM, AND WHEN TO BEVEL ROCKER PLATES, SEE STANDARD 27.02.

FINISH THESE SURFACES ANSI 250 IF DIMENSION 'Y' IS GREATER THAN 2\".

ANCHOR BOLTS, NUTS AND WASHERS SHALL BE GALVANIZED AS REQUIRED BY ASTM DESIGNATION A153, CLASS "C". PLATE "C" & "D" SHALL BE GALVANIZED. FOR UNPAINTED STRUCTURES PLATE "C" & "D" SHALL BE SHOP PAINTED AFTER GALVANIZING. PLATE "A" SHALL BE SHOP PAINTED. USE WELDABLE PRIMER ON PLATE "A\".

AT ABUTMENTS WHEN THE "X" DIMENSION OF PLATE "A" EXCEEDS 11" INCREASE STANDARD DISTANCE FROM C/L BRG. TO END OF GIRDER.

ALL MATERIAL INCLUDING SHIMS, BUT EXCLUDING STAINLESS STEEL SHEET, BRONZE PLATE, PINTLES, ANCHOR BOLTS, NUTS AND WASHERS SHALL CONFORM TO ASTM A709 GRADE 50W.

WELD SIZE, REFER TO STANDARD 24.2.

ADJUST HEIGHT IF TAPERED BEARINGS ARE REQUIRED.

FABRICATOR MAY INCREASE PLATE "A" OR PLATE "D" THICKNESS AS AN ALTERNATE TO SHIMS.

DIMENSION IS 2" WHEN 1/2\"/>

FOR NEW OR REPLACEMENT STEEL BEARINGS, INCLUDING STEEL BEARINGS USED FOR BRIDGE WIDENINGS, USE TYPE "A-T" AS SHOWN ON STANDARD 27.08. THIS STANDARD IS FOR INFORMATIONAL PURPOSES ONLY.

PROVIDE A METHOD FOR HANDLING PLATE "C" DURING GALVANIZING.

10" BEARING

CAP. KIPS	PLATE A		PLATE B		PLATE C			PLATE D			HEIGHT FEET
	X	Z	X	Z	X	Y	Z	X	Y	Z	
75	9"	10"	5"	10"	7"	1 1/2"	1'-0 1/4"	8"	1 1/2"	1'-8"	.354
105	11"	10"	7"	10"	9"	1 1/2"	1'-0 1/4"	8"	1 1/2"	1'-8"	.375
135	1'-1"	10"	9"	10"	11"	1 1/2"	1'-0 1/4"	8"	1 1/2"	1'-8"	.396
160	1'-3"	10"	11"	10"	1'-1"	2 3/4"	1'-0 1/4"	9"	1 1/2"	1'-8"	.432
190	1'-5"	10"	1'-1"	10"	1'-3"	2 1/4"	1'-0 1/4"	10"	1 1/2"	1'-8"	.495
220	1'-7"	10"	1'-3"	10"	1'-5"	3 1/4"	1'-0 1/4"	1'-0"	2"	1'-8"	.599
250	1'-9"	10"	1'-5"	10"	1'-7"	3 1/4"	1'-0 1/4"	1'-1"	2 3/4"	1'-8"	.630
280	1'-11"	10"	1'-7"	10"	1'-9"	4 1/4"	1'-0 1/4"	1'-3"	2 3/4"	1'-8"	.755
310	2'-1"	10"	1'-9"	10"	1'-11"	4 1/4"	1'-0 1/4"	1'-4"	2 3/4"	1'-8"	.755

12" BEARING

CAP. KIPS	PLATE A		PLATE B		PLATE C			PLATE D			HEIGHT FEET
	X	Z	X	Z	X	Y	Z	X	Y	Z	
90	9"	1'-0"	5"	1'-0"	7"	1 1/2"	1'-2 1/4"	8"	1 1/2"	1'-10"	.354
125	11"	1'-0"	7"	1'-0"	9"	1 1/2"	1'-2 1/4"	8"	1 1/2"	1'-10"	.375
160	1'-1"	1'-0"	9"	1'-0"	11"	1 1/2"	1'-2 1/4"	8"	1 1/2"	1'-10"	.396
195	1'-3"	1'-0"	11"	1'-0"	1'-1"	2 3/4"	1'-2 1/4"	9"	1 1/2"	1'-10"	.432
230	1'-5"	1'-0"	1'-1"	1'-0"	1'-3"	2 3/4"	1'-2 1/4"	11"	2"	1'-10"	.516
265	1'-7"	1'-0"	1'-3"	1'-0"	1'-5"	3 1/4"	1'-2 1/4"	1'-1"	2 3/4"	1'-10"	.630
300	1'-9"	1'-0"	1'-5"	1'-0"	1'-7"	3 1/4"	1'-2 1/4"	1'-2"	2 3/4"	1'-10"	.630
335	1'-11"	1'-0"	1'-7"	1'-0"	1'-9"	4 1/4"	1'-2 1/4"	1'-4"	2 3/4"	1'-10"	.755
370	2'-1"	1'-0"	1'-9"	1'-0"	1'-11"	4 1/4"	1'-2 1/4"	1'-5"	2 3/4"	1'-11"	.755

14" BEARING

CAP. KIPS	PLATE A		PLATE B		PLATE C			PLATE D			HEIGHT FEET
	X	Z	X	Z	X	Y	Z	X	Y	Z	
105	9"	1'-2"	5"	1'-2"	7"	1 1/2"	1'-4 1/4"	8"	1 1/2"	2'-0"	.354
145	11"	1'-2"	7"	1'-2"	9"	1 1/2"	1'-4 1/4"	8"	1 1/2"	2'-0"	.375
185	1'-1"	1'-2"	9"	1'-2"	11"	1 1/2"	1'-4 1/4"	8"	1 1/2"	2'-0"	.396
225	1'-3"	1'-2"	11"	1'-2"	1'-1"	2 3/4"	1'-4 1/4"	10"	1 1/2"	2'-0"	.453
270	1'-5"	1'-2"	1'-1"	1'-2"	1'-3"	2 3/4"	1'-4 1/4"	1'-0"	2"	2'-0"	.516
310	1'-7"	1'-2"	1'-3"	1'-2"	1'-5"	3 1/4"	1'-4 1/4"	1'-1"	2 3/4"	2'-0"	.630
350	1'-9"	1'-2"	1'-5"	1'-2"	1'-7"	3 1/4"	1'-4 1/4"	1'-3"	2 3/4"	2'-1"	.672
390	1'-11"	1'-2"	1'-7"	1'-2"	1'-9"	4 1/4"	1'-4 1/4"	1'-4"	2 3/4"	2'-1"	.755
435	2'-1"	1'-2"	1'-9"	1'-2"	1'-11"	4 1/4"	1'-4 1/4"	1'-6"	3 1/4"	2'-1"	.838

16" BEARING

CAP. KIPS	PLATE A		PLATE B		PLATE C			PLATE D			HEIGHT FEET
	X	Z	X	Z	X	Y	Z	X	Y	Z	
120	9"	1'-4"	5"	1'-4"	7"	1 1/2"	1'-6 1/4"	8"	1 1/2"	2'-2"	.354
165	11"	1'-4"	7"	1'-4"	9"	1 1/2"	1'-6 1/4"	8"	1 1/2"	2'-2"	.375
215	1'-1"	1'-4"	9"	1'-4"	11"	1 1/2"	1'-6 1/4"	9"	1 1/2"	2'-2"	.396
260	1'-3"	1'-4"	11"	1'-4"	1'-1"	2 3/4"	1'-6 1/4"	11"	2"	2'-2"	.474
310	1'-5"	1'-4"	1'-1"	1'-4"	1'-3"	2 3/4"	1'-6 1/4"	1'-0"	2"	2'-2"	.516
355	1'-7"	1'-4"	1'-3"	1'-4"	1'-5"	3 1/4"	1'-6 1/4"	1'-2"	2 3/4"	2'-3"	.630
400	1'-9"	1'-4"	1'-5"	1'-4"	1'-7"	3 1/4"	1'-6 1/4"	1'-3"	2 3/4"	2'-3"	.672
450	1'-11"	1'-4"	1'-7"	1'-4"	1'-9"	4 1/4"	1'-6 1/4"	1'-5"	2 3/4"	2'-3"	.755
500	2'-1"	1'-4"	1'-9"	1'-4"	1'-11"	4 1/4"	1'-6 1/4"	1'-7"	3 1/4"	2'-3"	.838

18" BEARING

CAP. KIPS	PLATE A		PLATE B		PLATE C			PLATE D			HEIGHT FEET
	X	Z	X	Z	X	Y	Z	X	Y	Z	
135	9"	1'-6"	5"	1'-6"	7"	1 1/2"	1'-8 1/4"	8"	1 1/2"	2'-4"	.354
185	11"	1'-6"	7"	1'-6"	9"	1 1/2"	1'-8 1/4"	8"	1 1/2"	2'-4"	.375
240	1'-1"	1'-6"	9"	1'-6"	11"	1 1/2"	1'-8 1/4"	9"	1 1/2"	2'-4"	.396
295	1'-3"	1'-6"	11"	1'-6"	1'-1"	2 3/4"	1'-8 1/4"	11"	2"	2'-4"	.474
350	1'-5"	1'-6"	1'-1"	1'-6"	1'-3"	2 3/4"	1'-8 1/4"	1'-1"	2 3/4"	2'-5"	.547
400	1'-7"	1'-6"	1'-3"	1'-6"	1'-5"	3 1/4"	1'-8 1/4"	1'-2"	2 3/4"	2'-5"	.630
455	1'-9"	1'-6"	1'-5"	1'-6"	1'-7"	3 1/4"	1'-8 1/4"	1'-4"	2 3/4"	2'-5"	.672
505	1'-11"	1'-6"	1'-7"	1'-6"	1'-9"	4 1/4"	1'-8 1/4"	1'-6"	3 1/4"	2'-5"	.838
560	2'-1"	1'-6"	1'-9"	1'-6"	1'-11"	4 1/4"	1'-8 1/4"	1'-8"	3 1/4"	2'-5"	.838

20" BEARING

CAP. KIPS	PLATE A		PLATE B		PLATE C			PLATE D			HEIGHT FEET
	X	Z	X	Z	X	Y	Z	X	Y	Z	
150	9"	1'-8"	5"	1'-8"	7"	1 1/2"	1'-10 1/4"	8"	1 1/2"	2'-6"	.354
210	11"	1'-8"	7"	1'-8"	9"	1 1/2"	1'-10 1/4"	8"	1 1/2"	2'-6"	.375
270	1'-1"	1'-8"	9"	1'-8"	11"	1 1/2"	1'-10 1/4"	10"	1 1/2"	2'-6"	.417
325	1'-3"	1'-8"	11"	1'-8"	1'-1"	2 3/4"	1'-10 1/4"	11"	2"	2'-6"	.474
385	1'-5"	1'-8"	1'-1"	1'-8"	1'-3"	2 3/4"	1'-10 1/4"	1'-1"	2 3/4"	2'-7"	.547
445	1'-7"	1'-8"	1'-3"	1'-8"	1'-5"	3 1/4"	1'-10 1/4"	1'-3"	2 3/4"	2'-7"	.672
505	1'-9"	1'-8"	1'-5"	1'-8"	1'-7"	3 1/4"	1'-10 1/4"	1'-5"	2 3/4"	2'-7"	.672
565	1'-11"	1'-8"	1'-7"	1'-8"	1'-9"	4 1/4"	1'-10 1/4"	1'-7"	3 1/4"	2'-7"	.838
625	2'-1"	1'-8"	1'-9"	1'-8"	1'-11"	4 1/4"	1'-10 1/4"	1'-9"	3 1/4"	2'-7"	.838

ANCHOR BOLT NOTES:

FOR SPAN LENGTHS UP TO 100'-0", USE A TYPE I MASONRY PLATE "D" WITH (2) 1 1/2" DIA. X 1'-5" LONG ANCHOR BOLTS.

FOR SPAN LENGTHS FROM 100'-0" TO 150'-0", USE A TYPE I MASONRY PLATE "D" WITH (2) 1 1/2" DIA. X 1'-10" LONG ANCHOR BOLTS.

FOR SPAN LENGTHS GREATER THAN 150'-0", USE A TYPE II MASONRY PLATE "D" WITH (4) 1 1/2" DIA. X 1'-10" LONG ANCHOR BOLTS.

DRILLED HOLES FOR ANCHOR BOLTS IN MASONRY PLATE "D" SHALL HAVE A DIAMETER 1/8" LARGER THAN ANCHOR BOLT.

EXPANSION BEARING DETAILS TYPE 'A' - STEEL GIRDERS



APPROVED: *Laura Shadewald*

DATE: 7-16