



Traffic Signal Design Manual

ORIGINATOR Director, Bureau of Highway Operations	7-1-2
CHAPTER 7	Sequence of Operations
SECTION 1	General
SUBJECT 2	NEMA Operations

Traffic signal phasing **shall** be in accordance with NEMA TS-1 standards for actuated signal controllers. Under NEMA phase designations, there can be a total of eight phases, which are grouped in two rings as illustrated below.

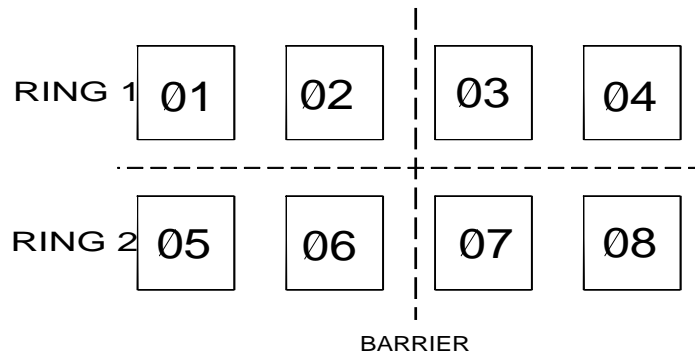

Figure 1
Ring Barrier Diagram

The phases are separated by what is referred to as a barrier, which prohibits servicing of conflicting phases that are in separate rings simultaneously.

For standard traffic signal phasing the vehicular movements **shall** be referenced to the associated NEMA phase numbers as designated below. The NEMA phase designation diagram represents an eight-phase signal operation with protected/permissive or protected-only left turns on all approaches. Pedestrian phasing, where applicable, *should* be designated by the complementary through movement phase associated with the specific pedestrian movement.

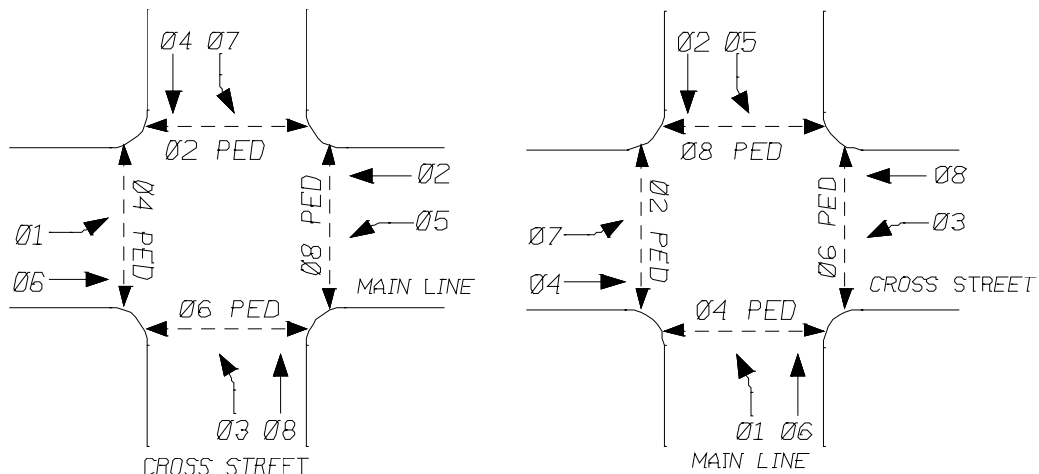

Figure 2
NEMA Phase Diagram

Phase 6 *should* normally be oriented in the mainline northbound or eastbound through direction for plan preparation purposes, with the remaining phases oriented according to the relationship illustrated on the previous page.

For signals on a state trunk highway, NEMA phase designation shall be used. For example, mainline east-west through movements *should* be called out as Ø6 and Ø2, not just Ø2 (or just Ø6), and cross street through movements should be called out as Ø8 and Ø4, not just Ø8 or Ø4. In addition, left turn phasing may be added in the future. Due to this, eight-phase dual-ring controllers shall be used at state-owned signals.

On local road systems, four-phase controllers *may* function efficiently at some locations, although their limited flexibility and capability *should* be evaluated prior to installation. Locations requiring future modifications such as left turn lanes *may* require additional phases, which a four-phase controller *may not* be capable of handling. Lead phasing as well as split phasing *may not* be possible due to the limited capability of a four-phase controller. In certain cases, due to their slightly lower cost and smaller physical size, four-phase controllers *may* be used.