



Wisconsin Department of Transportation

April 19, 2016

Division of Transportation Systems Development

Bureau of Project Development
 4802 Sheboygan Avenue, Rm 601
 P O Box 7916
 Madison, WI 53707-7916

Telephone: (608) 266-1631
 Facsimile (FAX): (608) 266-8459

NOTICE TO ALL CONTRACTORS:

**Proposal #47: 1610-03-62, WISC 2016 191
 Medford - Westboro
 STH 102 to North County Line
 STH 13
 Taylor County**

Letting of May 10, 2016

This is Addendum No. 01, which provides for the following:

Special Provisions

Revised Special Provisions	
Article No.	Description
3	Prosecution and Progress

Added Special Provisions	
Article No.	Description
33	Base Repair for CIR Pavement, Item SPV.0035.01
34	Prepare Foundation for CIR Pavement 1610-03-62, Item SPV.0105.03
35	Prepare Foundation for HMA Upper Layer 1610-03-62, Item SPV.0105.04
36	Cold-In-Place Recycling (CIR) Pavement Partial Depth, Item SPV.0180.01; Asphalt Stabilizing Agent Item SPV.0195.04

Deleted Special Provisions	
Article No.	Description
13	Preparation of Foundation for Asphaltic Paving
32	HMA Longitudinal Crack Repair, Item SPV.0195.03

Schedule of Items

Revised Bid Item Quantities					
Bid Item	Item Description	Unit	Old Quantity	Revised Quantity	Proposal Total
465.0105	Asphaltic Surface	Ton	1,560	150	1,710
643.0900	Traffic Control Signs	Day	1,081	621	1,702
649.0402	Temporary Pavement Marking Paint 4-Inch	LF	10,430	10,430	20,860

Added Bid Item Quantities					
Bid Item	Item Description	Unit	Old Quantity	Revised Quantity	Proposal Total
SPV.0035.01	Base Repair for CIR Pavement	CY	0	250	250
SPV.0105.03	Prepare Foundation for CIR Pavement 1610-03-62	LS	0	1	1
SPV.0105.04	Prepare Foundation for HMA Upper Layer 1610-03-62	LS	0	1	1
SPV.0180.01	Cold-In-Place Recycling (CIR) Pavement Partial Depth	SY	0	98200	98200
SPV.0195.04	Asphalt Stabilizing Agent	Ton	0	549	549

Deleted Bid Item Quantities					
Bid Item	Item Description	Unit	Old Quantity	Revised Quantity	Proposal Total
211.0100	Prepare Foundation for Asphaltic Paving (project) 01. 1610-03-62	LS	1	-1	0
SPV.0195.03	HMA Longitudinal Crack Repair	Ton	750	-750	0

Plan Sheets

Revised Plan Sheets	
Plan Sheet	Plan Sheet Title (brief description of changes to sheet)
3	Typical Sections. Added Cold-In-Place Recycling (CIR) Pavement Partial Depth to the finished typical section.
29	Miscellaneous Quantities. Added additional quantity to Asphaltic Surface
31	Miscellaneous Quantities. Added additional quantity to Traffic Control Signs
34	Miscellaneous Quantities. Added additional quantity to Temp Pavement Marking Paint 4-Inch
36	Miscellaneous Quantities. Removed HMA Longitudinal Crack Repair Item. Added Base Repair for CIR Pavement item. Added Cold-In-Place Recycling (CIR) Pavement Partial Depth item. Added Asphalt Stabilizing Agent item.

Added Plan Sheets	
Plan Sheet	Plan Sheet Title (brief description of why sheet was added)
3A	Pavement Core Log. Added pavement core log data to the plan.

Other

Revise the contract time for completion from 30 working days to 45 working days (an increase in 15 working days).

The responsibility for notifying potential subcontractors and suppliers of these changes remains with the prime contractor.

Sincerely,

Mike Coleman

Proposal Development Specialist
Proposal Management Section

ADDENDUM NO. 01

1610-03-62

April 19, 2016

Special Provisions

3. Prosecution and Progress.

Replace paragraph four with the following:

The contractor shall coordinate construction activities so that traffic does not travel on the milled asphaltic surface for longer than 10 (ten) calendar days prior to the Cold-In-Place Recycling (CIR) Pavement layer being completed. Commencing the day that milling operations begin, the contractor shall install and maintain "Grooved Pavement" (W8-15) signs in each direction of travel at a spacing not to exceed 1 mile throughout the milled area. The signs shall remain in place until the CIR pavement layer has been completed. The installation and maintenance of the "Grooved Pavement" signs is incidental to the Removing Asphaltic Surface Milling bid item. Placement of the HMA Pavement 4 SMA 58-34 V Special shall be started no later than five calendar days after optimal curing of the CIR has been achieved. This paving operation shall be completed as continuous as practical to avoid excessive damage to the cured CIR base from highway traffic.

13. DELETED.

32. DELETED.

33. Base Repair for CIR Pavement, Item SPV.0035.01

A Description

This special provision describes Base Repair for CIR Pavement in accordance with Preparation of Foundation for CIR Pavement and Preparation of Foundation for HMA Upper Layer areas in accordance with Section 211 of the Standard Specifications.

B (Vacant)

C Construction

Section 211.3.5 of the Standard Specifications is supplemented as follows:

Prior to and during the placement of the CIR Pavement the contractor shall also be responsible for the work covered under this item.

Perform work under this bid item in accordance with Section 205 of the Standard Specifications.

Remove soft and/or yielding areas of base to a maximum depth of 2-feet. All areas will be documented and information will be provided to the project engineer. If areas are found after paving operation begin, the project engineer will be notified of locations. Excavated area will be filled and compacted with material that meets the material requirements of Section 305 and Base Aggregate Dense 1 ¼-inch or Section 306 and Salvaged Asphaltic Pavement Base or Section 465 and Asphaltic Surface. Do not exceed plan quantity without written approval of the project engineer.

D Measurement

The department will measure Base Repair for CIR Pavement by the CY acceptably completed.

E Payment

The department will pay for measured quantities at the contract unit price under the following bid item:

ITEM NUMBER	DESCRIPTION	UNIT
SPV.0035.01	Base Repair for CIR Pavement	CY

Payment is full compensation for removing/excavating areas of base to a maximum of 2-feet, any saw cuts, providing, placing, and compacting dense graded base course and/or Salvaged Asphaltic Pavement Base, and traffic control.

34. Prepare Foundation for CIR Pavement 1610-03-62, Item SPV.0105.03

A Description

This special provision describes Preparation of Foundation for work required prior to Cold-In-Place Recycling (CIR) in accordance to standard spec 211 and as hereinafter provided.

B (Vacant)

C Construction

After any contract required surface mill, the engineer and contractor shall visually inspect the milled surface for yielding areas.

Yielding areas will then be repaired prior to the CIR process. The identified yielding areas will be excavated to a maximum of two feet and repaired with base course and a minimum of 5" Salvaged Asphaltic Pavement Base to the top of the milled surface.

- After any contract required surface milling, and immediately prior to commencing CIR operations, remove from the roadway, and up to one inch below the milled surface, any vegetation, standing water, loose crack filler, and any other deleterious materials.

D Measurement

The department will measure Prepare Foundation for CIR Pavement 1610-03-62 by the lump sum, acceptably completed.

E Payment

The department will pay for measured quantities at the contract unit price under the following bid item:

ITEM NUMBER	DESCRIPTION	UNIT
SPV.0105.03	Prepare Foundation for CIR Pavement 1610-03-62	LS

Omit and replace standard spec 211.5.1 (4) with the following:

Payment is full compensation for brooming, crack fill removal, any saw cuts, any additional milling, any test rolling, and for placement of acceptable material into these areas.

The department will pay separately for the following work associated with yielding areas under this item under the following contract items:

- Base Repair for CIR Pavement

35. Prepare Foundation for HMA Upper Layer 1610-03-62, Item SPV.0105.04.

A Description

This special provision describes preparation of foundation for work required prior to placement of the HMA upper layer after completion of Cold-In-Place Recycling (CIR) in accordance to standard spec 211 and as hereinafter provided.

B (Vacant)

C Construction

Prior to placement of the HMA upper layer, the engineer and contractor shall visually inspect the CIR layer for distresses including, but not limited to raveled areas, rutted areas, areas of excess or deficient stabilizing agent, yielding areas, or deficient surface tolerance areas.

Raveled areas, non-structural related rutted areas, areas of excess or deficient stabilizing agent, and deficient surface tolerance areas shall be re-processed or repaired at no additional cost to the department.

Yielding areas will be excavated to a maximum depth of two feet and repaired with base course and a minimum of 5" Asphaltic Surface to the top of the CIR Layer.

Prior to the upper HMA layer being placed, the contractor shall monitor and the test the CIR layer for moisture content. The contractor shall provide to the engineer results demonstrating that the CIR layer throughout the project meets the requirements of C.9.1 Curing of the Cold In-Place Recycling (CIR) Pavement Partial Depth SPV.

D Measurement

The department will measure Prepare Foundation for HMA Upper Layer 1610-03-62 by the lump sum, acceptably completed.

E Payment

The department will pay for measured quantities at the contract unit price under the following bid item:

ITEM NUMBER	DESCRIPTION	UNIT
SPV.0105.04	Prepare Foundation for HMA Upper Layer 1610-03-62	LS

Omit and replace standard spec 211.5.1 (4) with the following:

Payment is full compensation for furnishing all work under this item including moisture testing and correcting surface tolerance deviations; and for furnishing all labor, tools, equipment, materials, and incidentals necessary to complete the contract work.

The department will pay separately for the following work associated with yielding areas under this item under the following pertinent contract items:

- Asphaltic Surface for mix placed under this item to correct yielding areas
- Base Repair for CIR Pavement.

36. Cold-In-Place Recycling (CIR) Pavement Partial Depth, Item SPV.0180.01; Asphalt Stabilizing Agent Item SPV.0195.04

A Description

This work consists of the partial depth milling, crushing, and screening (as necessary) of the existing HMA pavement to the width and depth specified on the plans. The processed material shall be blended with engineered emulsified or foamed asphalt stabilizing agent, water, and other additives as necessary, and required by the mix design, for placement and compaction of this mixture in accordance with the plans and specifications.

B Materials

B.1 Reclaimed Asphalt Pavement (RAP) Material

The RAP shall be milled from the existing roadway and processed in-place.

The RAP shall be free of contamination of base material, shoulder material, concrete, silt, clay, or other deleterious materials.

Rubberized crack filler, pavement markers, loop wires, fabric, or other materials shall be removed as observed from the roadway during the recycling process. Any residual materials shall be appropriately sized and homogeneously blended with the RAP.

The milled and processed material shall conform to the following gradation prior to addition of the stabilizing agent:

<u>Sieve Size</u>	<u>Percent Passing</u>
1 1/2" (37.5 mm)	100
1"	95 to 100

B.2 Stabilizing Agent

The asphalt stabilizing agent shall be the contractor's option of:

- Foamed asphalt
- Emulsion

B.2.1 Foamed Asphalt

Foamed asphalt shall be produced with a performance graded asphalt binder; without polymer modification; in accordance with Standard Specification 455.

Asphalt binder performance grade for foamed asphalt shall be PG 46-34 or PG 52-34

Asphalt binder shall be sufficiently heated to meet the mix design expansion and half-life criteria; not to exceed 375° F.

Asphalt binder shall produce asphalt foam with a minimum expansion ratio of 8 and half-life of no less than 6 seconds.

B.2.2 Emulsion

Emulsion type shall be determined by the mix design.

B.2.3 Water

Water may be added to the RAP at the milling head and/or in a mixing chamber.

Water added to the RAP, used for foaming asphalt, or incorporated with the asphalt emulsion shall meet the requirements of Standard Specification 501.2.4.

B.3 Mixture Design

The contractor will be responsible for obtaining milled samples and/or cores for the project mix design.

Develop and submit a material sampling plan to the engineer; for review with and approval by the Bureau of Technical Services Materials Management Section; 5 business days prior to obtaining milled and/or cored samples.

Material sampling prior to receipt of the engineers notice to proceed shall require submittal and approval of an Application/Permit to Work on Highway Right-of-Way (DT1812).

During material sampling operations; contractor insurance will be as specified in section 107 of the Standard Specifications; traffic control requirements will be as specified in sections 107 and 643 of the Standard Specifications and in the contract special provisions.

Develop and submit a Job Mix Formula (JMF) for approval 10 business days prior to the start of the CIR operation. The JMF will be developed according to the applicable portions of Mix Design Method 1559, as described in WisDOT CMM 8.65; and conforming to the requirements of Table B.3. The JMF will be submitted to the engineer for review with and approval by the Bureau of Technical Services Materials Management Section.

Table B.3 – Minimum Mix Design Requirements

	Test Method	Specification	Criteria	
Mix Design Requirements for All Stabilizing Agents	Gradation of RAP (Sieve Analysis of Aggregates)	WisDOT Mix Design Method 1559; CMM 8-65.5	See Section B.1.(4)	
	Bulk Specific Gravity of Compacted Samples		Report Only; Ndes=30	
	Maximum Theoretical Specific Gravity		Report Only	
	% Air Voids in Compacted Dense and Open Bituminous Paving Mixtures		Report Only	
	Tensile Strength (Resistance of Compacted Mixture to Moisture)		Dry, psi Wet (conditioned), psi Ratio (TSR), %	Minimum 45 Minimum 30 Minimum 0.70
	RAP Coating Test			
	Minimum Virgin Asphalt Content			1.5%
	Mix Design Requirements for Foamed Asphalt		Foamed Asphalt Expansion Ratio	
Foamed Asphalt Half-life			Minimum 6.0 Seconds	
Mix Design Requirements for Emulsified Asphalt	Emulsion sieve test, % of sample weight	AASHTO T 59(1)	Maximum 0.1	
	Emulsion Residue by Distillation, %	AASHTO T 59 (1)	Minimum 60	
	Emulsion Distillation Penetration, 25°C, 100 g, 5s	AASHTO T 49	Minimum 75 Maximum 200	
	Maximum Emulsified Asphalt Temperature		Report Only	

Modify AASHTO T 59 procedure – distillation temperature of 175°C ± 5°C with a 20 minute hold.

The mix design JMF shall be the baseline measure for the rate of stabilizing agent application and water blended with the RAP to construct the CIR mixture. The mix design shall indicate the allowable tolerance for field adjustments for the stabilizing agent and/or water so as not to jeopardize the performance of the mix in regards to Table B.3, but allow the contractor to adjust the mix in response to field conditions.

The mix design report shall contain the following minimum information:

- Gradation of RAP
- Density, maximum specific gravity, air void content, indirect dry tensile strength, indirect wet (conditioned) tensile strength, and tensile strength ratio at each recycling agent content iteration (minimum of 4; inclusive of recommended moisture and stabilizing contents) and at the recommended moisture and stabilizing agent contents
- Recommended water content range as a percentage of dry RAP
- Optimum stabilizing agent content as a percentage of dry RAP
- Stabilizing agent designation, PG grading of asphalt binder if applicable, supplier name and location, emulsified asphalt residue asphalt content if applicable, and certificates of compliance
- Application means of recycling agent
- RAP coating test results for emulsified asphalt recycling agent
- Allowable tolerances for field adjustments for stabilizing agent and/or water.

B.4 Quality Management Program

B.4.1 Quality Control Plan

Submit a comprehensive written quality control plan to the engineer no later than 10 business days before beginning CIR activities. Construct the project as the plan provides.

Do not change the quality control plan without the engineer's review and acceptance. Update the plan with changes as they become effective. Provide a current copy of the plan to the engineer and post in the contractor's laboratory as changes are adopted. Ensure that the plan provides the following elements:

- An organizational chart with names, telephone numbers, current certifications and/or titles, and roles and responsibilities of QC personnel.
- The process used to disseminate QC information and corrective action efforts to the appropriate persons. Include a list of recipients, the communication process that will be used, and action time frames.
- A list of suppliers for all stabilizing agents.
- A list of source locations for all water.
- An outline for resolving a process control problem. Include responsible personnel, required documentation, and appropriate communication steps.
- Location of the QC laboratory, retained sample storage, and other documentation.
- A summary of locations or quantities, selected randomly using ASTM Method D3665, to be tested under this provision.

B.4.2 Personnel

Provide HTCP Nuclear Density Technician I, or ACT certified technician, for performance of field density and field moisture content testing.

If an ACT is performing sampling or testing, a certified technician must coordinate and take responsibility for the work an ACT performs. Have a certified technician ensure that all sampling and testing is performed correctly, analyze test results, and post resulting data. No more than one ACT can work under a single certified technician.

B.4.3 Equipment

Furnish the necessary equipment and supplies for performing quality control testing. Ensure that all testing equipment conforms to the equipment specifications applicable to the required testing methods. The engineer may inspect the measuring and testing devices to confirm both calibration and condition. Calibrate all testing equipment according to the CMM and applicable AASHTO and/or ASTM specifications and maintain a calibration record at the laboratory.

Furnish nuclear gauges from the department's approved product list at:

<http://www.dot.wisconsin.gov/business/engrserv/approvedprod.htm>

Ensure that the nuclear gauge manufacturer or an approved calibration service calibrates the gauge the same calendar year it is used on the project. Retain a copy of the calibration certificate with the gauge.

Conform to ASTM D 6938 and CMM 8.15 for density testing and gauge monitoring methods.

B.4.4 Quality Control (QC) Testing

Roadway production lots will be defined as 4000 lane feet. Each roadway production lot will consist of two- 2000 lane feet sublots.

Roadway samples shall be taken at a minimum frequency of 1 per lot of production.

Samples shall be taken representative of the full recycled depth, immediately prior to application of the stabilizing agent.

For each roadway sample report the gradation of material, determined in accordance with AASTHO T27, for the Number 4 (4.75mm) sieve and larger.

Report stabilizing agent foaming properties, if applicable, (i.e. half life and expansion ratio) at a minimum frequency of 1 per lot of production.

Conduct and report density testing at a minimum frequency of 3 random tests per sublot.

Conduct and report mill depth checks at a minimum frequency of 1 per sublot.

Report stabilizing agent temperature and application rate at a minimum frequency of 1 per sublot.

The contractor shall provide a Daily Inspection Report to the engineer summarizing the: daily beginning and ending stations, applicable mix design, sublot test (mill depth check, density test, stabilizing agent temperature and application rate) locations and values, lot roadway sample locations, and any adjustments to the application rate of the stabilizing agent or water.

If at any time during production, stabilizing agent adjustments for mixing and placement exceed the allowable limits defined in B.3.(6) or reduce the stabilizing agent application rate below the 1.5% mix design minimum specified in Table B.3, based on a single test or meter adjustment, from the Job Mix Formula (JMF) value, re-evaluation of the entire process must be completed. Approval by the engineer granted before production can resume.

B.4.5 Department Testing

B.4.5.1 General

The department will conduct verification testing to validate the quality of the product and independent assurance testing to evaluate the sampling and testing. The department will provide the contractor with a listing of names and telephone numbers of all QV and IA personnel for the project, and provide test results to the contractor within 5 business days after the department obtains the sample.

B.4.5.2 Quality Verification (QV) Testing

The department will have a technician, or ACT working under a technician, perform QV sampling and testing. Department verification testing personnel must meet the same certification level requirements specified in B.4.2 for contractor testing personnel for each test result being verified. The department will notify the contractor before sampling so the contractor can observe QV sampling.

The department will conduct QV tests at the minimum frequency of 10% of the required QC tests.

The department will locate gradation, mill depth check, roadway sample, and density test samples, at locations independent of the contractor's QC work, collecting one sample at each QV location. The department will split each QV sample, test half for QV, and retain the remaining half for 7 calendar days.

The department will conduct QV tests in a separate laboratory and with separate equipment from the contractor's QC tests. The department will use the same methods specified for QC testing.

The department will assess QV results by comparing to the appropriate specification limits. If QV test results conform to this special provision, the department will take no further action. If QV test results are nonconforming, re-evaluation of the entire process must be completed before production can resume.

The department reserves the right to adjust the rate of the asphalt stabilizing agent at any time. The department will accept any risk to the CIR layer associated any adjustments made by the department.

B.4.5.3 Independent Assurance (IA)

Independence assurance is unbiased testing the department performs to evaluate the department's QV and the contractor's QC sampling and testing, including personnel qualifications, procedures, and equipment. The department will perform an IA review according to the department's independent assurance program. That review may include one or more of the following:

1. Split sample testing.
2. Proficiency sample testing.
3. Witnessing sampling and testing.
4. Test equipment calibration checks.
5. Requesting that testing personnel perform additional sampling and testing.

If the department identifies a deficiency, and after further investigation confirms it, correct that deficiency. If the contractor does not correct or fails to cooperate in resolving identified deficiencies, the engineer may suspend placement until action is taken. Resolve disputes as specified in B.4.5.4.

B.4.5.4 Dispute Resolution

The engineer and contractor should make every effort to avoid conflict. If a dispute between some aspect of the contractor's and the engineer's testing program does occur, seek a solution mutually agreeable to the project personnel. The department and contractor shall review the data, examine data reduction and analysis methods, evaluate sampling and testing methods/procedures, and perform additional testing. Use ASTM E 178 to evaluate potential statistically outlying data.

Production test results, and results from other process control testing, may be considered when resolving a dispute.

If project personnel cannot resolve a dispute, and the dispute affects payment or could result in incorporating non-conforming product or work, the department will use third party testing to resolve the dispute. The department's central office laboratory, or a mutually agreed on independent testing laboratory, will provide this testing. The engineer and contractor will abide by the results of the third party tests. The party in error will pay service charges incurred for testing by an independent

laboratory. The department may use third party test results to evaluate the quality of questionable materials and determine the appropriate payment. The department may reject material or otherwise determine the final disposition of nonconforming material as specified in standard spec 106.5.

C Construction

C.1 General

Unless the contract provides otherwise, keep the road open to traffic during construction.

Perform CIR operations; only between the dates of May 1 and October 1; when the air temperature approximately 3 feet above grade, in shade, and away from artificial heat sources is above 50°F and when the nighttime ambient air temperature is above 45°F the night prior and following; unless approved otherwise by the engineer.

Do not perform CIR operations during inclement weather; such as rain or fog; that will not allow proper mixing, placing, and/or compacting of the mixture.

CIR operations and recycled pavement curing shall be completed to allow adequate time for placement of surfacing in accordance with calendar requirements of Standard Specification section 450.3.2.1.

C.2 Equipment

Equipment used for CIR shall be subject to approval by the engineer.

Tankers supplying hot stabilizing agent components shall be equipped to constantly monitor temperature within the tank.

C.2.1 Milling Machine

Milling units; not inclusive of pre-mill/wedge-cut milling units; shall be capable of milling the existing pavement full lane width to the depth shown on the plans, specified in the contract or directed by the engineer, in a single pass.

The units shall be equipped with automatic depth control, shall maintain constant cutting depth and width, uniform grade, and uniform slope.

For processes not incorporating additional screening, sizing, or crushing; the milling unit shall be capable of producing RAP sized as specified in B.1.

Use of a heating device to soften the pavement is not permitted.

C.2.2 Screening, Crushing, and Sizing Equipment

Processes requiring additional screening, sizing, or crushing, shall include a unit with a closed circuit system capable of continuously returning oversized material to the crusher until all milled material entering the screening, crushing, or sizing equipment meets the gradation requirements of section B.1.

C.2.3 Mixing Unit

Processed RAP shall be mixed with the stabilizing agent and water in a mixing unit; defined as the milling machine cutter housing, a separate mixing chamber, or a pugmill.

The asphalt stabilizing agent shall be applied; using a computer controlled additive system; uniformly at the predetermined application rate. The metering of the stabilizing agent must be monitored through a calibrated pump providing a continuous readout of quantities.

The additive system shall contain separate pumping systems for adding stabilizing agent and water. Each system shall have an inspection or test nozzle for stabilizing agent and/or water sampling.

The system shall be capable of producing a uniformly mixed homogeneous recycled pavement mixture.

C.2.4 Paving Equipment

The placement and shaping of the recycled pavement mixture shall be completed using a self-propelled paver or screed integral to the recycling equipment meeting the requirements of Standard Specification section 450.3.1.4; revised to exclude the requirement of an activated screed or strike-off assembly.

The screed shall not be heated.

If utilizing a self-propelled paver, the material shall be transferred directly into the paver hopper from the recycling equipment or with a pick-up device. When a pick-up device is used, the entire windrow shall be removed from the milled surface and transferred to the paver hopper.

C.2.5 Compaction Equipment

Compaction equipment shall be self-propelled and meet the requirements of Standard Specification 450.3.1.5

The number, weight, and types of rollers shall be as necessary to achieve the specified compaction.

C.3 Constructing CIR

C.3.1 Preparation

After any contract required surface milling, and immediately prior to commencing CIR operations, remove from the roadway, and up to one inch below the milled surface, any vegetation, standing water, loose crack filler, and any other deleterious materials.

Inspect the pavement surface, after any contract required surface milling, for areas of yielding subgrade. Yielding areas will be repaired prior to CIR operations and paid for in accordance with the Prepare Foundation for CIR Pavement SPV item.

Blade the existing base aggregate roadway shoulders away from the asphaltic surface edge to minimize contamination of the CIR pavement.

C.3.2 Processing and Placement of Recycled Pavement Mixture

Mill the existing pavement to the required depth and width indicated on the plans.

Further process the milled RAP material as necessary by crushing, screening, and/or sizing to the gradation requirements of B.1.

Blend the RAP material with the mix design specified proportions of stabilizing agent and water; produce a uniform and homogeneous recycled mixture.

Spread the recycled mixture to the grade, elevations, and slopes specified on the plans; avoiding tearing or scarring of the recycled pavement surface.

Ensure proper material transfer, handling, and spreading to prevent particle segregation.

Longitudinal joints between successive CIR operations shall be overlapped a minimum of 3 inches. Transverse joints between successive CIR operations shall be overlapped a minimum of 2 feet.

C.4 Compaction

C.4.1 Control Strip Construction

On the first day of production, construct a control strip to identify the target wet density for the CIR layer. The control strip construction and density testing will occur under the direct observation and/or assistance of the department QV personnel.

Unless the Engineer approves otherwise, construct control strips to a minimum dimension of 500 feet long and one full lane width.

Completed control strips may remain in-place to be incorporated into the final roadway cross-section.

Construct additional control strips, at a minimum, when:

- The CIR layer thickness changes in excess of 2.0 inches.
- The percent of target density is less than 90% or exceeds 105.0%; and is outside the range of the 10 random measurements defining the control strip; on three consecutive sublots.
- Construct control strips using equipment and methods representative of the operations to be used for constructing the CIR layer.
- After compacting the control strip with a minimum of 2 passes, mark and take density measurements at 3 random locations, at least 1 ½ feet from the edge of the CIR layer. Subsequent density measurements will be taken at the same 3 locations.
- After each subsequent pass of compaction equipment over the entirety of the control strip, take density measurements at the 3 marked locations. Continue compacting and testing until the increase in density measurements is less than 2.0 lb/ft³, or the density measurements begin to decrease.
- Upon completion of control strip compaction, take 10 randomly located density measurements within the limits of the control strip, at least 1 ½ feet from the edge of the base. The final measurements recorded at the 3 locations under article paragraph (6) of this section may be included as 3 of the 10 measurements. Average the 10 measurements to obtain the control strip target density.

C.4.2 Compaction Requirements

Compact the CIR layer to a required density of 93% of the target density.

C.5 Surface Requirements

Test the pavement surface at regular intervals, and engineer selected locations, using a 10-foot straightedge or other engineer specified device.

The engineer may direct the repair of surface deviations greater than 1/4 inch between two surface contact points. High points shall be corrected by reworking, rerolling, trimming, milling, or grinding. Depressions may be corrected by reworking or have a tack coat applied and be filled with HMA immediately prior to placement of the surface treatment.

C.6 Maintaining the Work

After compaction is complete, the contractor will determine when the CIR is stable to open to traffic.

After opening to traffic, and prior to placing a surface treatment, the surface of the recycled pavement shall be maintained in a condition suitable for safe movement of traffic.

The recycled pavement surface shall be protected and maintained from standing water, deleterious substances, and/or other damage.

Any damage to the recycled pavement shall be repaired by the contractor prior to placement of the upper layer at no additional cost to the department; unless otherwise specified in the "Preparation of Foundation for HMA Upper Layer" SPV item.

C.9 Curing and Surfacing

C.9.1 Curing

Application of a surface treatment will not be allowed until the moisture content of the CIR layer is not more than 1.5%.

If the moisture content of the CIR layer does not reduce to 1.5%; the surface treatment may be applied after the change in moisture content is less than 0.10 percentage points for three consecutive calendar days.

C.9.2 Tack Coat

The surface shall be prepared and tack coat applied meeting the requirements of Standard Specification section 455.3.2.

Minimum tack coat application rate shall be 0.05 gal/SY

A hot asphaltic cement tack coat shall not be used.

C.9.3 Surfacing

Surfacing materials, equipment, and construction methods shall be in accordance with the applicable sections of the Standard Specifications or contract special provisions.

D Measurement

The department will measure the Asphalt Stabilizing Agent incorporated into the work by the ton; as metered through a calibrated pump, or through delivered ticket quantity.

The department will measure the Cold-In-Place (CIR) Pavement Partial Depth bid item as acceptably completed by the Square Yard (SY).

E Payment

The department will pay for the measured quantities at the contract unit price under the following bid item:

ITEM NUMBER	DESCRIPTION	UNIT
SPV.0180.02	Cold-In-Place Recycling (CIR) Pavement Partial Depth	SY
SPV.0195.02	Asphalt Stabilizing Agent	Ton

Payment is full compensation for measured quantities as specified above; all material including mixing and milling water; equipment necessary for milling and sizing, mixing, paving, compacting the completed CIR; and for furnishing all labor, tools, and incidentals necessary to the conduct mix design; including sampling and sampling traffic control; mill the existing pavement for recycling, size the milled RAP, inject and mix the RAP with the stabilizing agent, place or pave, compact, and maintain the completed CIR.

Preparation work and repair of yielding areas will be paid for under the Prepare Foundation for CIR Pavement and Prepare Foundation for HMA Upper Layer SPV items.

Removing or blading away of the adjacent shoulder material will be paid for under the Standard Specifications Shaping Shoulders (305.0500).

Surfacing treatments, including tack coat, will be constructed and paid for under the applicable specifications and contract items.

Schedule of Items

Attached, dated April 19, 2016, are the revised Schedule of Items Pages 1 – 7.

Plan Sheets

The following 8½ x 11-inch sheets are attached and made part of the plans for this proposal:

Revised: 3, 29, 31, 34 and 36.

Added: 3A.

END OF ADDENDUM

Addendum No. 01
ID 1610-03-62
Revised Sheet 3
April 19, 2016

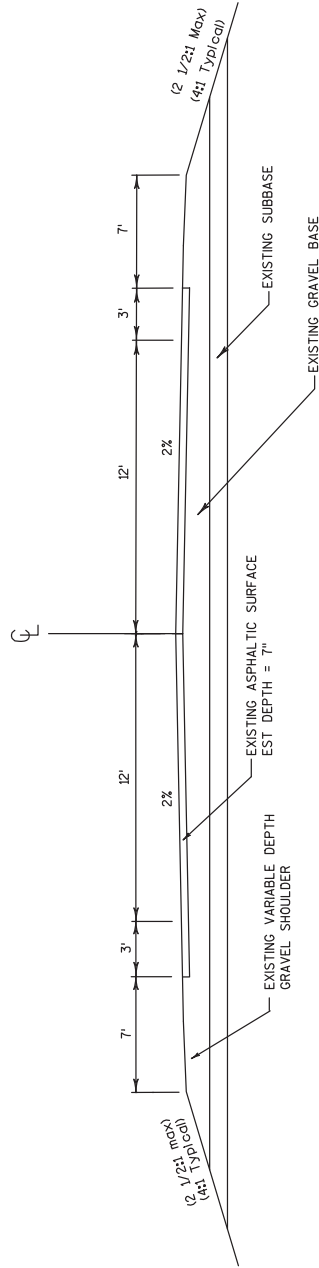

TYPICAL EXISTING SECTION

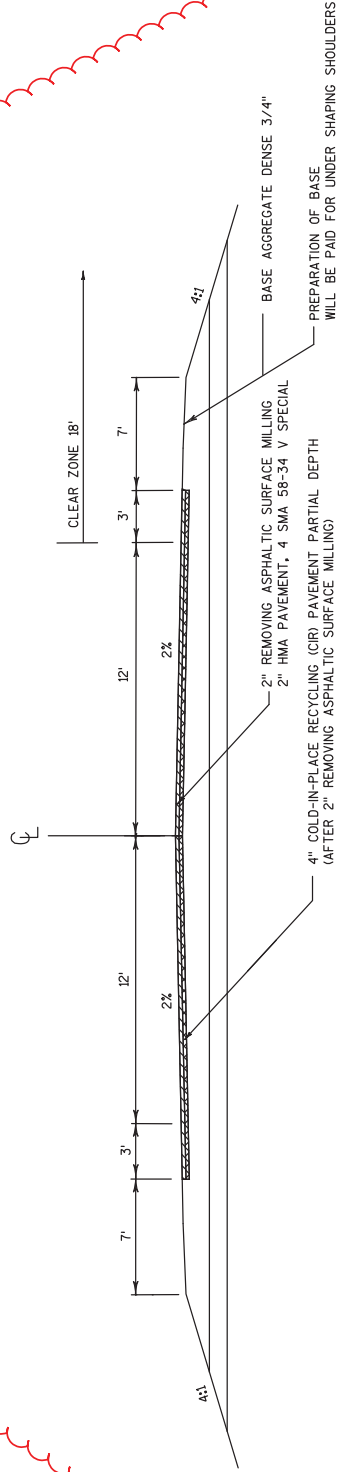

FINISHED TYPICAL SECTION

NOTE: SEE PAVEMENT CORE LOG SHEET FOR EXISTING PAVEMENT DEPTHS.
 CORE DEPTHS WERE SUPPLEMENTED WITH GROUND PENETRATING RADAR.
 GROUND PENETRATING RADAR DATA SHOWING ASPHALTIC SURFACE LAYER THICKNESS IS AVAILABLE BY CONTACTING PHIL KEEPPERS (715)395-3027.

Addendum No. 01
ID 1610-03-62
Added Sheet 3A
April 19, 2016

CORE NUMBER	PAVEMENT CORE LOG		*EXISTING ASPHALTIC SURFACE DEPTH
	APPROXIMATE STATION	OFFSET	
1	465+00	9' RT	** 3.75 "
2	478+00	4' LT	8.00 "
3	491+50	6' RT	5.50 "
4	504+50	6' LT	8.00 "
5	518+00	4' RT	5.50 "
6	531+00	9' LT	6.00 "
7	544+00	9' RT	4.75 "
8	557+50	4' LT	7.50 "
9	570+50	6' RT	** 9.88 "
10	585+00	6' LT	7.00 "
11	597+00	4' RT	5.75 "
12	610+00	9' LT	6.75 "
13	623+50	9' RT	** 9.75 "
14	636+50	4' LT	** 9.50 "
15	651+00	6' RT	6.00 "
16	663+00	6' LT	7.75 "
17	676+00	4' RT	8.00 "
18	689+50	9' LT	7.25 "
19	702+50	9' RT	6.50 "
20	715+00	4' LT	5.50 "
21	729+00	6' RT	7.50 "
22	742+00	6' LT	7.25 "
23	752+50	4' RT	6.50 "

PAVEMENT CORE DATA COLLECTED ON MARCH 22, 2016.

*EXISTING ASPHALTIC SURFACE DEPTH VARIES THROUGHOUT THE LENGTH OF THE PROJECT. THE DEPTHS LISTED ON THIS CORE LOG ARE FOR THE LISTED LOCATIONS ONLY.

**UNABLE TO RECOVER ENTIRE PAVEMENT CORE, DEPTH LISTED IS FOR THE PORTION OF THE CORE THAT WAS RECOVERED.

Removing Asphaltic Surface Butt Joints

CAT	STATION TO	STATION	LOCATION	SY
				204.0115
0010	454+50 -	455+00		167
0010	604+10 -	604+60		167
0010	606+70 -	607+20		167
0010	648+54 -	649+04		167
0010	650+34 -	650+84		167
0010	755+00 -	755+50	Intersections	167
0010	454+50 -	755+50	Intersections	750
			TOTAL 0010	1752

REMOVING APRON ENDWALLS

CATEGORY	STATION	LOCATION	EACH
			204.9060. S
0010	458+65	Rt	1
0010	586+86	Rt	1
0010	592+05	Lt	1
0010	679+05	Lt	1
0010	746+80	Lt	1
		TOTAL 0010	5

Backfill Granular

CAT	STATION	LOCATION	CY
			209.0100
0010	458+60	Rt	5
0010	586+86	Rt	10
0010	592+05	Lt & Rt	20
0010	679+05	Lt	5
0010	746+80	Rt	5
		TOTAL 0010	45

Removing Asphaltic Surface Milling

CAT	STATION TO	STATION	LOCATION	SY
				204.0120
0010	455+00 -	604+10	Mainline	49700
0010	607+20 -	648+54		13780
0010	650+84 -	755+00		34720
0010	Intersections,	Turn Lanes & PES		6400
		TOTAL 0010		104600

Removing Curb & Gutter

CAT	STATION TO	STATION	LOCATION	LF
				204.0150
0010	611+15 -	611+30	Lt	45
0010	611+50 -	612+10	Rt	65
0010	611+65 -	612+35	Lt	75
		TOTAL 0010		185

Tack Coat

CAT	STATION TO	STATION	LOCATION	GAL
				455.0605
0010	454+50 -	755+50	Mainline	6944
0010	454+50 -	755+50	Intersections, Turn Lanes & PES	500
0010			Levelling	300
		TOTAL 0010		7744

Asphaltic Surface

CAT	STATION TO	STATION	LOCATION	TON
				465.0105
0010	454+50 -	755+50	Levelling	500
0010	Intersections,	Turn Lanes & PES		800
0010	Beam Guard	Shoulder Paving		210
0010		Prep of Foundation		200
		TOTAL 0010		1710

ASPHALT CENTER LINE RUMBLE STRIPS 2-LANE RURAL

CATEGORY	STATION	TO	STATION	LF
				465.0475
0010	454+50	-	751+00	26010
			TOTAL 0010	26010

Addendum No. 01
ID 1610-03-62
Revised Sheet 29
April 19, 2016

Fertilizer Type B

CAT	STATION	LOCATION	CWT
0010	458+65	Lt & Rt	0.1
0010	460+80	Lt & Rt	0.1
0010	468+55	Lt & Rt	0.1
0010	500+55	Lt & Rt	0.1
0010	512+65	Lt & Rt	0.1
0010	545+05	Lt & Rt	0.1
0010	554+52	Lt & Rt	0.1
0010	586+86	Lt & Rt	0.2
0010	592+05	Lt & Rt	0.3
0010	668+05	Rt	0.1
0010	679+05	Lt & Rt	0.1
0010	692+35	Lt	0.1
0010	714+35	Lt & Rt	0.1
0010	746+80	Lt & Rt	0.1
TOTAL 0010			1.7

Markers Culvert End

CAT	STATION	LOCATION	EACH
0010	458+65	Lt & Rt	2
0010	460+80	Lt & Rt	2
0010	468+55	Lt & Rt	2
0010	500+55	Lt & Rt	2
0010	512+65	Lt & Rt	2
0010	519+05	Lt & Rt	2
0010	545+05	Lt & Rt	2
0010	554+52	Lt & Rt	2
0010	586+86	Lt & Rt	2
0010	592+05	Lt & Rt	2
0010	599+05	Lt & Rt	2
0010	668+05	Lt & Rt	2
0010	679+05	Lt & Rt	2
0010	692+35	Lt & Rt	2
0010	714+35	Lt & Rt	2
0010	746+80	Lt & Rt	2
TOTAL 0010			32

Seeding Mixture No. 10

CAT	STATION	LOCATION	LB
0010	458+65	Lt & Rt	1
0010	460+80	Lt & Rt	1
0010	468+55	Lt & Rt	1
0010	500+55	Lt & Rt	1
0010	512+65	Lt & Rt	1
0010	545+05	Lt & Rt	1
0010	554+52	Lt & Rt	1
0010	586+86	Lt & Rt	4
0010	592+05	Lt & Rt	7
0010	668+05	Rt	1
0010	679+05	Lt & Rt	1
0010	692+35	Lt	1
0010	714+35	Lt & Rt	1
0010	746+80	Lt & Rt	1
TOTAL 0010			23

TRAFFIC CONTROL SIGNS

CATEGORY	STATION	LOC SIGN CODE	SIGN MESSAGE	SIZE	DAY
0010	434+50	RT W20-1	ROAD WORK AHEAD	48x48	74
0010	444+50	RT W20-1C	ROAD WORK 1000 FT	48x48	74
0010	449+50	RT W20-1D	ROAD WORK 500 FT	48x48	74
0010	452+00	RT G20-1	ROAD WORK NEXT 6 MILES	60x24	74
0010	452+00	LT G20-2A	END ROAD WORK	42x24	74
0010	STH 102	RT W20-1	ROAD WORK AHEAD	48x48	74
0010	Fawn Ave	LT W20-1	ROAD WORK AHEAD	48x48	74
0010	Fawn Ave	RT W20-1	ROAD WORK AHEAD	48x48	74
0010	Gunmar Ave	LT W20-1	ROAD WORK AHEAD	48x48	74
0010	Old 13 Rd	RT W20-1	ROAD WORK AHEAD	48x48	74
0010	Fischer Creek Rd	LT W20-1	ROAD WORK AHEAD	48x48	74
0010	Business 13	RT W20-1	ROAD WORK AHEAD	48x48	74
0010	Business 13	LT W20-1	ROAD WORK AHEAD	48x48	74
0010	CTH D	RT W20-1	ROAD WORK AHEAD	48x48	74
0010	Peterson Lane	LT W20-1	ROAD WORK AHEAD	48x48	74
0010	Peterson Lane	RT W20-1	ROAD WORK AHEAD	48x48	74
0010	Business 13	RT W20-1	ROAD WORK AHEAD	48x48	74
0010	Johnson Ave	LT W20-1	ROAD WORK AHEAD	48x48	74
0010	758+00	RT G20-1	ROAD WORK NEXT 6 MILES	60x24	74
0010	758+00	LT G20-2A	END ROAD WORK	42x24	74
0010	760+50	LT W20-1D	ROAD WORK 500 FT	48x48	74
0010	765+50	LT W20-1C	ROAD WORK 1000 FT	48x48	74
0010	775+50	LT W20-1	ROAD WORK AHEAD	48x48	74
TOTAL 0010					1702

TRAFFIC CONTROL DRUMS

CATEGORY	STATION TO	STATION	LOCATION	DAY	REMARKS
0010	611+15	-	611+30	Lt	50
0010	611+50	-	612+10	Rt	50
0010	611+65	-	612+35	Lt	50
TOTAL 0010				150	

Pavement Marking Epoxy 4-1/2 inch

CAT	STATION TO	STATION	LOCATION	LF	REMARKS
0010	454+50	-	755+50	Mainline	15325
0010	454+50	-	755+50	Mainline	60190
0010			CTH D West	320	Centerline, after rumble strips have been milled
0010			CTH D East	320	Edgeline
0010			CTH D West	320	Centerline
0010			CTH D East	320	Edgeline
0010			CTH D West	320	Edgeline
0010			CTH D East	320	Edgeline
TOTAL 0010				76795	

Pavement Marking Epoxy 8-1/2 inch

CAT	LOCATION	LF
0010	Wayside Rt Turn Lane	100
0010	CTH D East Rt Turn Lane	175
0010	CTH D West Rt Turn Lane	175
TOTAL 0010		450

PAVEMENT MARKING STOP LINE EPOXY 18-INCH

CATEGORY	STATION	LOCATION	LF
0010	658+10	Lt	20
0010	658+30	Lt	15
0010	658+45	Rt	15
0010	658+70	Rt	20
TOTAL 0010			70

Addendum No. 01
 ID 1610-03-62
 Revised Sheet 31
 April 19, 2016

634. 0616 POSTS WOOD 4' x6' x16' 637. 2210 SIGNS TYPE II REFLECTIVE TYPE H 637. 2230 SIGNS TYPE II REFLECTIVE TYPE F 638. 2602 REMOVE SIGNS TYPE II 638. 3000 REMOVE SMALL SIGN SUPPORTS

CAT NO.	STATION TO	STATION CODE	SIZE	LOC	EACH	SF	SF	EACH	EACH	MESSAGE
0010	71	693+49 - 693+49	M1-94	72" x15"	RT	2	11.00	1	2	PETERSON LA
0010	72	693+49 - 693+49	D1-61	66" x24"	RT	2	11.00	1	2	PETERSON LN [DBA]
0010	73	698+75 - 698+75	R1-1	30" x30"	LT	1	5.18	1	1	STOP
0010	74	699+75 - 699+75	R1-1	30" x30"	RT	1	5.18	1	1	STOP
0010	75	705+86 - 705+86	M1-94	72" x15"	LT	2	11.00	1	2	PETERSON LA
0010	76	705+86 - 705+86	D1-61	66" x24"	LT	2	11.00	1	2	PETERSON LN [DBA]
0010	77	710+39 - 710+39	M1-94	96" x15"	RT	2	8.75	1	2	BUSINESS HWY 13
0010	78	710+39 - 710+39	D1-1	84" x15"	RT	2	8.75	1	2	BUSINESS HWY 13 [RA]
0010	79	712+14 - 712+14	D7-62	60" x42"	LT	2	17.50	1	2	ROAD TO NAT'L FOREST CAMPGROUND 1 MILE
0010	80	716+25 - 716+25	R1-1	30" x30"	RT	1	5.18	1	1	STOP
0010	81	722+75 - 722+75	M1-94	96" x15"	LT	2	8.75	1	2	BUSINESS HWY 13
0010	82	722+75 - 722+75	D1-1	84" x15"	LT	2	8.75	1	2	[LA] BUS HWY 13
0010	83	747+35 - 747+35	M1-94	60" x15"	RT	2	9.38	1	2	JOHNSON AVE
0010	84	747+35 - 747+35	D1-1	90" x15"	RT	2	9.38	1	2	[LA] JOHNSON AVE
0010	85	751+21 - 751+21	I-55-56	30" x36"	LT	1	7.50	1	1	ADOPT-A-HIGHWAY (WESTBORO FISH AND WILDLIFE INC)
0010	86	753+68 - 753+68	I-2-2	54" x15"	RT	1	5.63	1	1	PRICE CO
0010	87	753+85 - 753+85	I-2-2	54" x15"	LT	1	5.63	1	1	TAYLOR CO
0010	88	752+85 - 752+85	R1-1	30" x30"	LT	1	5.18	1	1	STOP

PAGE TOTAL 19 105.86 0.00 13 19
 PROJECT TOTAL 0010 97 596.66 42.00 75 97

Pavement Marking Same Day Epoxy 4-1 Inch

Locating No-Passing Zones

Temporary Pavement Marking Paint 4-1 Inch

CAT	STATION TO	STATION	LOC	REMARKS	LF	LF	REMARKS
0010	454+50 - 755+50	Mainline	15325	Centerline	15325	648.0100	
0010	454+50 - 755+50	Project	6		6		
TOTAL 0010					15325	648.0100	
0010	454+50 - 755+50	Mainline	10430	Millred Surface	10430		
0010	454+50 - 755+50	Mainline	10430	CIR Surface	10430		
TOTAL 0010					20860		

Addendum No. 01
 ID 1610-03-62
 Revised Sheet 34
 April 19, 2016

Special 05. Temporary Portable Rumble Strip Array

CAT	LOCATION	SPV. 0060. 05 EACH
0010	Undr stri buted	4
TOTAL 0010		4

SPECIAL 01. CONCRETE CURB AND GUTTER CURE AND SEAL TREATMENT

CATEGORY	STATION TO	LOCATION	SPV. 0090. 01 LF
0010	611+15 -	611+30 Lt	45
0010	611+50 -	612+10 Rt	65
0010	611+65 -	612+35 Lt	75
TOTAL 0010			185

Special 01. Reheating HMA Pavement Longitudinal Joints Special

CAT	STATION TO	LOCATION	STA	REMARKS	SPV. 0170. 01 CY
0010	454+50 -	755+50	Project	301	
TOTAL 0010					301

Special 01. Base Repair for CIR Pavement

CAT	STATION TO	LOCATION	SPV. 0035. 01 CY
0010	454+50 -	755+50 Project	250
TOTAL 0010			250

Special 01. HMA Pavement 4 SMA 58-34 V Special

CAT	STATION TO	LOCATION	SPV. 0195. 01 TON
0010	454+50 -	755+50 Project	11235
TOTAL 0010			11235

Special 02. SMA Pavement Compaction Acceptance

CAT	STATION TO	LOCATION	Project	SPV. 0195. 02 TON
0010	454+50 -	755+50	Project	11235
TOTAL 0010				11235

Special 01. Cold-In-Place Recycling (CIR) Pavement Partial Depth

CAT	STATION TO	LOCATION	SPV. 0180. 01 SY
0010	455+00 -	604+10 Mainline	49700
0010	607+20 -	648+54 Mainline	13780
0010	650+84 -	755+00 Mainline	34720
TOTAL 0010			98200

Special 04. Asphalt Stabilizing Agent

CAT	STATION TO	LOCATION	SPV. 0195. 04 TON
0010	455+00 -	604+10 Mainline	278
0010	607+20 -	648+54 Mainline	77
0010	650+84 -	755+00 Mainline	194
TOTAL 0010			549

Addendum No. 01
ID 1610-03-62
Revised Sheet 36
April 19, 2016

SCHEDULE OF ITEMS

REVISED:

CONTRACT:
20160510047

PROJECT(S):
1610-03-62

FEDERAL ID(S):
WISC 2016191

CONTRACTOR : _____

LINE NO	ITEM DESCRIPTION	APPROX. QUANTITY AND UNITS	UNIT PRICE		BID AMOUNT	
			DOLLARS	CTS	DOLLARS	CTS

SECTION 0001 Contract Items

0010	204.0115 Removing Asphaltic Surface Butt Joints	1,752.000 SY
0020	204.0120 Removing Asphaltic Surface Milling	104,600.000 SY
0030	204.0150 Removing Curb & Gutter	185.000 LF
0040	204.9060.S Removing (item description) 01. Apron Endwalls	5.000 EACH
0050	209.0100 Backfill Granular	45.000 CY
0070	213.0100 Finishing Roadway (project) 01. 1610-03-62	1.000 EACH
0080	305.0110 Base Aggregate Dense 3/4-Inch	6,169.000 TON
0090	305.0500 Shaping Shoulders	596.000 STA
0100	440.4410 Incentive IRI Ride	9,136.000 DOL	1.00000	.	9136.00	.
0110	455.0605 Tack Coat	7,744.000 GAL

SCHEDULE OF ITEMS

REVISED:

CONTRACT:
20160510047PROJECT(S):
1610-03-62FEDERAL ID(S):
WISC 2016191

CONTRACTOR : _____

LINE NO	ITEM DESCRIPTION	APPROX. QUANTITY AND UNITS	UNIT PRICE		BID AMOUNT	
			DOLLARS	CTS	DOLLARS	CTS
0120	465.0105 Asphaltic Surface	1,710.000 TON
0130	465.0475 Asphalt Center Line Rumble Strips 2-Lane Rural	26,010.000 LF
0140	520.8000 Concrete Collars for Pipe	5.000 EACH
0150	522.1024 Apron Endwalls for Culvert Pipe Reinforced Concrete 24-Inch	3.000 EACH
0160	522.1030 Apron Endwalls for Culvert Pipe Reinforced Concrete 30-Inch	1.000 EACH
0170	522.1036 Apron Endwalls for Culvert Pipe Reinforced Concrete 36-Inch	1.000 EACH
0180	601.0557 Concrete Curb & Gutter 6-Inch Sloped 36-Inch Type D	185.000 LF
0190	614.0370 Steel Plate Beam Guard Energy Absorbing Terminal	3.000 EACH
0200	614.0950 Replacing Guardrail Posts and Blocks	35.000 EACH
0210	618.0100 Maintenance And Repair of Haul Roads (project) 01.1610-03-62	1.000 EACH

SCHEDULE OF ITEMS

REVISED:

CONTRACT:
20160510047PROJECT(S):
1610-03-62FEDERAL ID(S):
WISC 2016191

CONTRACTOR : _____

LINE NO	ITEM DESCRIPTION	APPROX. QUANTITY AND UNITS	UNIT PRICE		BID AMOUNT	
			DOLLARS	CTS	DOLLARS	CTS
0220	619.1000 Mobilization	1.000 EACH	.		.	
0230	628.1504 Silt Fence	1,050.000 LF	.		.	
0240	628.1520 Silt Fence Maintenance	1,050.000 LF	.		.	
0250	628.1905 Mobilizations Erosion Control	2.000 EACH	.		.	
0260	628.1910 Mobilizations Emergency Erosion Control	2.000 EACH	.		.	
0270	628.2008 Erosion Mat Urban Class I Type B	1,490.000 SY	.		.	
0280	629.0210 Fertilizer Type B	1.700 CWT	.		.	
0290	630.0110 Seeding Mixture No. 10	23.000 LB	.		.	
0300	633.5200 Markers Culvert End	32.000 EACH	.		.	
0310	634.0616 Posts Wood 4x6-Inch X 16-FT	97.000 EACH	.		.	
0320	637.2210 Signs Type II Reflective H	596.660 SF	.		.	

SCHEDULE OF ITEMS

REVISED:

CONTRACT:
20160510047PROJECT(S):
1610-03-62FEDERAL ID(S):
WISC 2016191

CONTRACTOR : _____

LINE NO	ITEM DESCRIPTION	APPROX. QUANTITY AND UNITS	UNIT PRICE		BID AMOUNT	
			DOLLARS	CTS	DOLLARS	CTS
0330	637.2230 Signs Type II Reflective F	42.000 SF
0340	638.2602 Removing Signs Type II	75.000 EACH
0350	638.3000 Removing Small Sign Supports	97.000 EACH
0360	642.5001 Field Office Type B	1.000 EACH
0370	643.0100 Traffic Control (project) 01.1610-03-62	1.000 EACH
0380	643.0300 Traffic Control Drums	150.000 DAY
0390	643.0900 Traffic Control Signs	1,702.000 DAY
0400	646.0106 Pavement Marking Epoxy 4-Inch	76,795.000 LF
0410	646.0126 Pavement Marking Epoxy 8-Inch	450.000 LF
0420	646.0406 Pavement Marking Same Day Epoxy 4-Inch	15,325.000 LF
0430	647.0566 Pavement Marking Stop Line Epoxy 18-Inch	70.000 LF

SCHEDULE OF ITEMS

REVISED:

CONTRACT:
20160510047PROJECT(S):
1610-03-62FEDERAL ID(S):
WISC 2016191

CONTRACTOR : _____

LINE NO	ITEM DESCRIPTION	APPROX. QUANTITY AND UNITS	UNIT PRICE		BID AMOUNT	
			DOLLARS	CTS	DOLLARS	CTS
0440	648.0100 Locating No-Passing Zones	6.000 MI
0450	649.0402 Temporary Pavement Marking Paint 4-Inch	20,860.000 LF
0460	650.5500 Construction Staking Curb Gutter and Curb & Gutter	185.000 LF
0470	650.8000 Construction Staking Resurfacing Reference	30,100.000 LF
0480	650.9910 Construction Staking Supplemental Control (project) 01. 1610-03-62	LUMP	LUMP	.	.	.
0490	ASP.1T0A On-the-Job Training Apprentice at \$5.00/HR	1,200.000 HRS	5.00000	.	6000.00	.
0500	ASP.1T0G On-the-Job Training Graduate at \$5. 00/HR	300.000 HRS	5.00000	.	1500.00	.
0510	SPV.0060 Special 01. Resetting Culvert Sections	8.000 EACH
0520	SPV.0060 Special 02. Cleaning Culvert Pipes Minimal	14.000 EACH
0530	SPV.0060 Special 03. Cleaning Culvert Pipes Full	9.000 EACH

SCHEDULE OF ITEMS

REVISED:

CONTRACT:
20160510047PROJECT(S):
1610-03-62FEDERAL ID(S):
WISC 2016191

CONTRACTOR : _____

LINE NO	ITEM DESCRIPTION	APPROX. QUANTITY AND UNITS	UNIT PRICE		BID AMOUNT	
			DOLLARS	CTS	DOLLARS	CTS
0540	SPV.0060 Special 04. Barrier System Grading Shaping Finishing Special	3.000 EACH
0550	SPV.0060 Special 05. Temporary Portable Rumble Strip Array	4.000 EACH
0560	SPV.0090 Special 01. Concrete Curb and Gutter Cure and Seal Treatment	185.000 LF
0570	SPV.0105 Special 01. Material Transfer Vehicle	LUMP	LUMP	.	.	.
0580	SPV.0105 Special 02. Milling and Removing Temporary Joint	LUMP	LUMP	.	.	.
0590	SPV.0170 Special 01. Reheating HMA Pavement Longitudinal Joints Special	301.000 STA
0600	SPV.0195 Special 01. HMA Pavement 4 SMA 58-34 V Special	11,235.000 TON
0610	SPV.0195 Special 02. SMA Pavement Compaction Acceptance	11,235.000 TON
0630	SPV.0035 Special 01. Base Repair for CIR Pavement	250.000 CY
0640	SPV.0105 Special 03. Prepare Foundation for CIR Pavement 1610-03-62	LUMP	LUMP	.	.	.

SCHEDULE OF ITEMS

REVISED:

CONTRACT:
20160510047

PROJECT(S):
1610-03-62

FEDERAL ID(S):
WISC 2016191

CONTRACTOR : _____

LINE NO	ITEM DESCRIPTION	APPROX. QUANTITY AND UNITS	UNIT PRICE		BID AMOUNT	
			DOLLARS	CTS	DOLLARS	CTS
0650	SPV.0105 Special 04. Prepare Foundation for HMA Upper Layer 1610-03-62	LUMP	LUMP			.
0660	SPV.0180 Special 01. Cold-In-Place Recycling (CIR) Pavement Partial Depth	98,200.000 SY		.		.
0670	SPV.0195 Special 04. Asphalt Stabilizing Agent	549.000 TON		.		.
	SECTION 0001 TOTAL					.
	TOTAL BID					.