

EAU
PROJECT ID:
WITH: N/A

7823-07-73

COUNTY:
EAU CLAIRE

MAY 2022

ORDER OF SHEETS

Section No.	1	Title
Section No.	2	Typical Sections and Details
Section No.	3	Estimate of Quantities
Section No.	3	Miscellaneous Quantities
Section No.	4	Right of Way Plat
Section No.	5	Plan and Profile
Section No.	6	Standard Detail Drawings
Section No.	7	Sign Plates
Section No.	8	Structure Plans
Section No.	9	Computer Earthwork Data
Section No.	9	Cross Sections

TOTAL SHEETS = 110

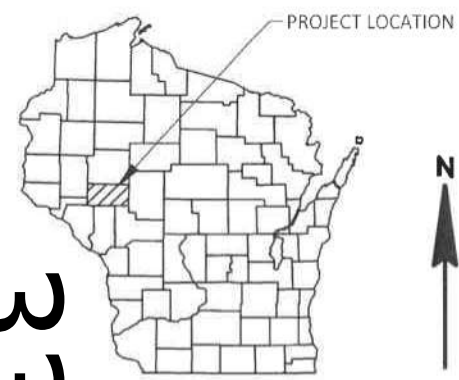

DESIGN DESIGNATION

A.A.D.T. (2022)	=	340
A.A.D.T. (2042)	=	375
D.H.V.	=	N/A
D.D.	=	50/50
T.	=	14.7%
DESIGN SPEED	=	55 MPH
ESALS	=	102,200

CONVENTIONAL SYMBOLS

PLAN	PROFILE
CORPORATE LIMITS	GRADE LINE
PROPERTY LINE	ORIGINAL GROUND
LOT LINE	MARSH OR ROCK PROFILE (To be noted as such)
LIMITED HIGHWAY EASEMENT	SPECIAL DITCH
EXISTING RIGHT OF WAY	GRADE ELEVATION
PROPOSED OR NEW R/W LINE	CULVERT (Profile View)
SLOPE INTERCEPT	UTILITIES
REFERENCE LINE	ELECTRIC
EXISTING CULVERT	FIBER OPTIC
PROPOSED CULVERT (Box or Pipe)	GAS
COMBUSTIBLE FLUIDS	SANITARY SEWER
MARSH AREA	STORM SEWER
WOODED OR SHRUB AREA	TELEPHONE
	WATER
	UTILITY PEDESTAL
	POWER POLE
	TELEPHONE POLE

STATE OF WISCONSIN
 DEPARTMENT OF TRANSPORTATION
 PLAN OF PROPOSED IMPROVEMENT
 FALL CREEK - NCL
 CTH XX TO STH 27
 CTH D
 EAU CLAIRE COUNTY

STATE PROJECT NUMBER
 7823-07-73

BEGIN PROJECT
 STA 9+73.36
 Y = 282,458.04
 X = 415,339.85

END PROJECT
 STA 204+98.10

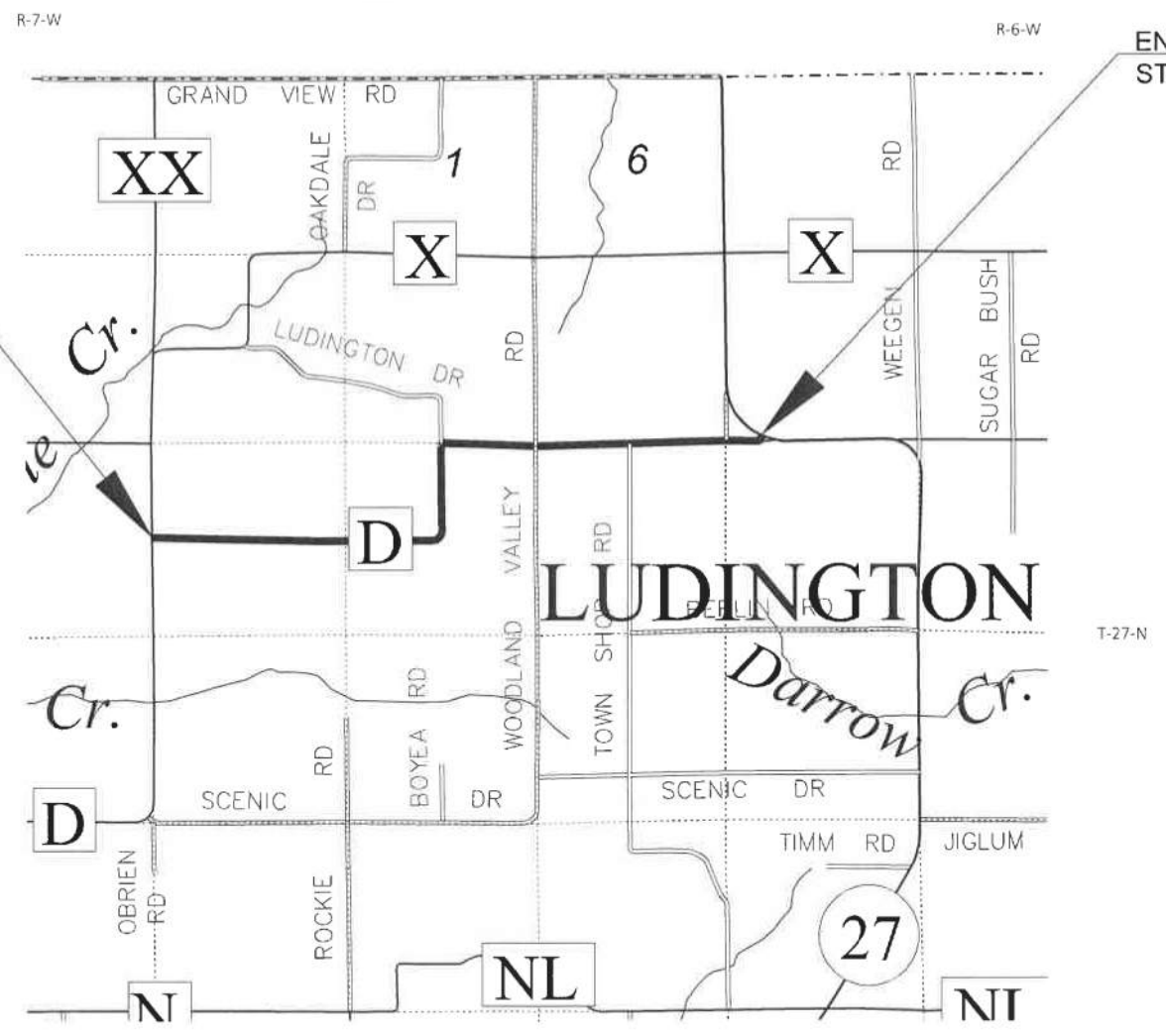

LAYOUT
 SCALE 0 1 MI
 TOTAL NET LENGTH OF CENTERLINE = 3.698 MI

HORIZONTAL POSITIONS SHOWN ON THIS PLAN ARE WISCONSIN COORDINATE REFERENCE SYSTEM (WISCRS), EAU CLAIRE COUNTY, NAD83 (2011), IN U.S. SURVEY FEET. POSITIONS SHOWN ARE GRID COORDINATES, GRID BEARINGS, AND GRID DISTANCES. GRID DISTANCES ARE THE SAME AS GROUND DISTANCES. ELEVATIONS ARE REFERENCED TO NAVD 88 (2012). GPS DERIVED ELEVATIONS ARE BASED ON GEOID 12A.

STATE PROJECT	FEDERAL PROJECT	
	PROJECT	CONTRACT
7823-07-73	WISC 2022259	1

ACCEPTED FOR
 EAU CLAIRE COUNTY
 Date 10/11/21 *Jan Johnson* Commissioner
 (Signature and Title of Official)

ORIGINAL PLANS PREPARED BY
CORRE
 ENGINEERING

PROFESSIONAL ENGINEER
 KEVIN L. MEYER
 E-39309-008
 ELK MOUND WI
 10/11/21

DATE: _____
 (Professional Engineer Signature)

STATE OF WISCONSIN
 DEPARTMENT OF TRANSPORTATION
 PREPARED BY
 Surveyor CORRE, INC.
 Designer CORRE, INC.
 Project Manager MATTHEW THORNSEN, PE
 Regional Examiner TOLU YANG, PE
 Regional Supervisor TYLER RONGSTAD, PE

APPROVED FOR THE DEPARTMENT
 DATE: 10/12/2021 *[Signature]*
 (Signature)

E

GENERAL NOTES

WHEN THE QUANTITY OF BASE AGGREGATE OR ASPHALTIC SURFACE IS MEASURED FOR PAYMENT BY THE TON OR CUBIC YARD, THE DEPTH OR THICKNESS OF THE LAYER SHOWN ON THE PLANS IS APPROXIMATE AND THE ACTUAL THICKNESS WILL DEPEND ON THE DISTRIBUTION OF THE MATERIAL AS DIRECTED BY THE ENGINEER.

THE LOCATION OF EXISTING AND PROPOSED UTILITY INSTALLATIONS AS SHOWN ON THE PLANS IS APPROXIMATE. THERE MAY BE OTHER UTILITY INSTALLATIONS WITHIN THE PROJECT AREA THAT ARE NOT SHOWN.

SECTION CORNER MONUMENTS WILL BE IMPACTED BY THE PROJECT AND ARE SHOWN WITHIN THE CONSTRUCTION PLANS. THE EAU CLAIRE COUNTY SURVEYOR'S OFFICE WILL PERPETUATE AND RE-MONUMENT ANY EFFECTED CORNERS OUTSIDE OF THE PROJECT. CONTACT THE SURVEYORS OFFICE PRIOR TO CONSTRUCTION AND AGAIN AT THE COMPLETION OF PAVING OPERATIONS SO THE SURVEYOR'S OFFICE CAN PLAN THEIR RE-MONUMENTATION WORK.

NO TREES OR SHRUBS ARE TO BE REMOVED WITHOUT THE APPROVAL OF THE ENGINEER.

THE EXACT LOCATION OF THE EROSION CONTROL DEVICES SHALL BE DETERMINED IN THE FIELD.

ALL CURB AND GUTTER RADII, PAVEMENT DIMENSIONS AND STATIONS ARE SHOWN TO THE EDGE OF PAVEMENT UNLESS NOTED OTHERWISE.

ALL SIDE ROAD EARTHWORK QUANTITIES ARE INCLUDED IN MAINLINE EARTHWORK QUANTITIES.

A VERTICAL SAWCUT SHALL BE MADE THROUGH EXISTING DRIVEWAYS AND PAVEMENTS AT REMOVAL LIMITS.

EXCAVATION BELOW SUBGRADE (EBS) IS NOT USED TO BALANCE YARDAGE AND IS SHOWN ON THE CROSS SECTIONS BUT IS MEASURED AND PAID FOR AS COMMON EXCAVATION.

CTH D BORINGS LOG

BORING NO	STATION	ASPHALTIC PAVEMENT DEPTH (IN)	BASE DEPTH (IN)
B-1	30+00 (WB LANE)	3.25	10.5
B-2	77+00 (EB LANE)	3.5	4.5
B-4	165+00 (WB LANE)	4.5	3.5
B-5	196+00 (EB LANE)	3.5	8

UTILITY CONTACTS

LUMEN - COMMUNICATIONS
 BRIAN HUHN
 425 ELLINGSON AVE
 HAWKINS, WI 54530
 PHONE: (715) 563-8294
 EMAIL: BRIAN.HUHN@LUMEN.COM

EAU CLAIRE ENERGY COOPERATIVE - ELECTRICITY
 JOSH VANINGAN
 8214 HWY 12
 FALL CREEK, WI 54742-0368
 PHONE: (715) 832-1603
 EMAIL: JVANINGAN@ECEC.COM

VIKING GAS TRANSMISSION COMPANY - GAS
 ANTHONY RICCI
 13506 COUNTY HIGHWAY OO
 CHIPPEWA FALLS, WI 54729
 PHONE: (715) 559-8011
 EMAIL: ANTHONY.RICCI@ONEOK.COM

RUNOFF COEFFICIENT TABLE

	HYDROLOGIC SOIL GROUP											
	A			B			C			D		
	SLOPE RANGE (PERCENT)			SLOPE RANGE (PERCENT)			SLOPE RANGE (PERCENT)			SLOPE RANGE (PERCENT)		
LAND USE:	0-2	2-6	6 & OVER	0-2	2-6	6 & OVER	0-2	2-6	6 & OVER	0-2	2-6	6 & OVER
ROW CROPS	.08 .22	.16 .30	.22 .38	.12 .26	.20 .34	.27 .44	.15 .30	.24 .37	.33 .50	.19 .34	.28 .41	.38 .56
MEDIAN STRIP-TURF	.19 .24	.20 .26	.24 .30	.19 .25	.22 .28	.26 .33	.20 .26	.23 .30	.30 .37	.20 .27	.25 .32	.30 .40
SIDE SLOPE-TURF			.25 .32			.27 .34			.28 .36			.30 .38
PAVEMENT:												
ASPHALT	.70 - .95											
CONCRETE	.80 - .95											
BRICK	.70 - .80											
DRIVES, WALKS	.75 - .85											
ROOFS	.75 - .95											
GRAVEL ROADS, SHOULDERS	.40 - .60											

TOTAL PROJECT AREA = 31.92 ACRES
 TOTAL AREA EXPECTED TO BE DISTURBED BY CONSTRUCTION ACTIVITIES = 2.01 ACRES

WISDOT CONTACT

NORTHWEST REGION
 MATTHEW THORNSEN
 718 WEST CLAIREMONT AVE
 EAU CLAIRE, WI 54701-5108
 PHONE: (715) 225-4159
 EMAIL: MATTHEW.THORNSEN@DOT.WI.GOV

COUNTY CONTACT

HIGHWAY COMMISSIONER
 JON JOHNSON
 2000 SPOONER AVE
 ALTOONA, WI 54702
 PHONE: (715) 839-2952
 EMAIL: JON.JOHNSON@CO.EAUCLAIRE.WI.US

COUNTY SURVEYOR

EAU CLAIRE COUNTY SURVEYOR
 DEAN ROTH
 721 OXFORD AVE. SUITE 3344
 EAU CLAIRE, WI 54703
 PHONE: (715) 839-4742
 EMAIL: DEAN.ROTH@CO.EAU-CLAIRE.WI.US

DNR CONTACT

DNR WEST CENTRAL REGION HEADQUARTERS
 LEAH NICOL
 1300 WEST CLAIREMONT AVE
 EAU CLAIRE, WI 54701
 PHONE: (715) 836-6571
 EMAIL: LEAH.NICOL@WISCONSIN.GOV

DESIGN CONTACT

CORRE, INC.
 KEVIN MEYER
 1802 WARDEN ST
 EAU CLAIRE, WI 54703
 PHONE: (715) 299-1894
 EMAIL: KMEYER@CORREINC.COM





PROJECT NO: 7823-07-73	HWY: CTH D	COUNTY: EAU CLAIRE	PROJECT OVERVIEW	SHEET	E
------------------------	------------	--------------------	------------------	-------	---

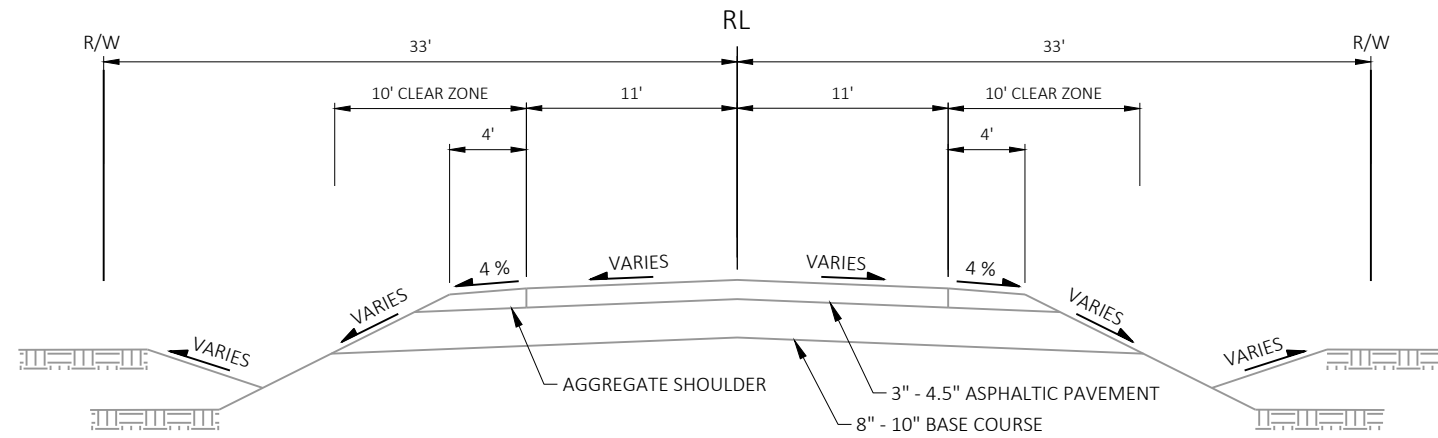

EXISTING TYPICAL SECTION - CTH D

STA 9+73.36 - 204+98

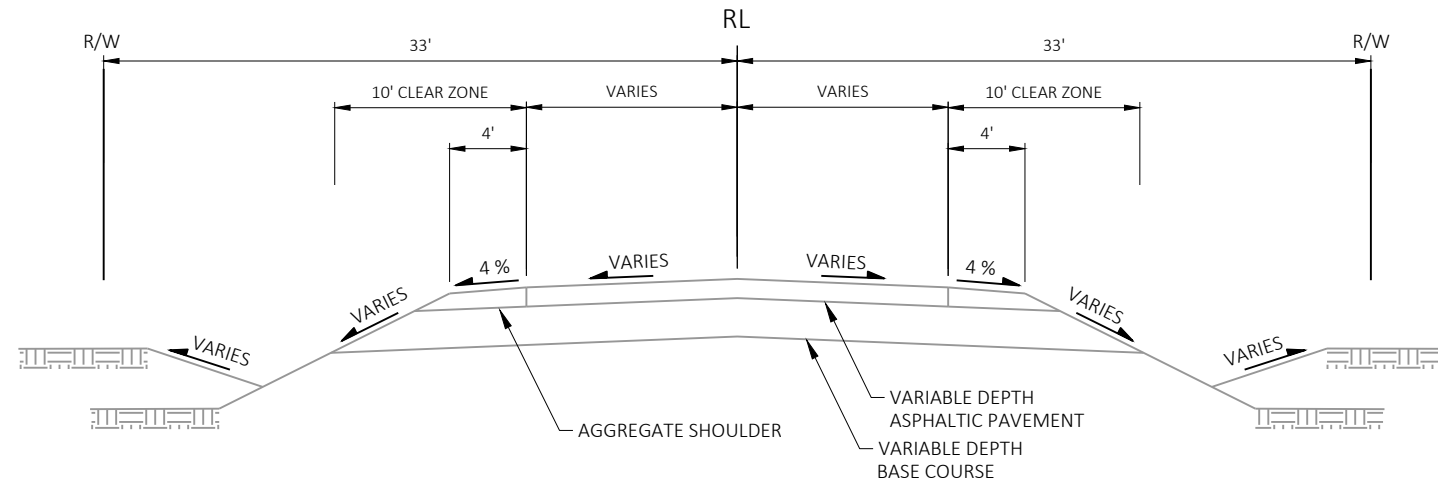

EXISTING TYPICAL SECTION - LUDINGTON DRIVE

STA 300+00 - 301+65

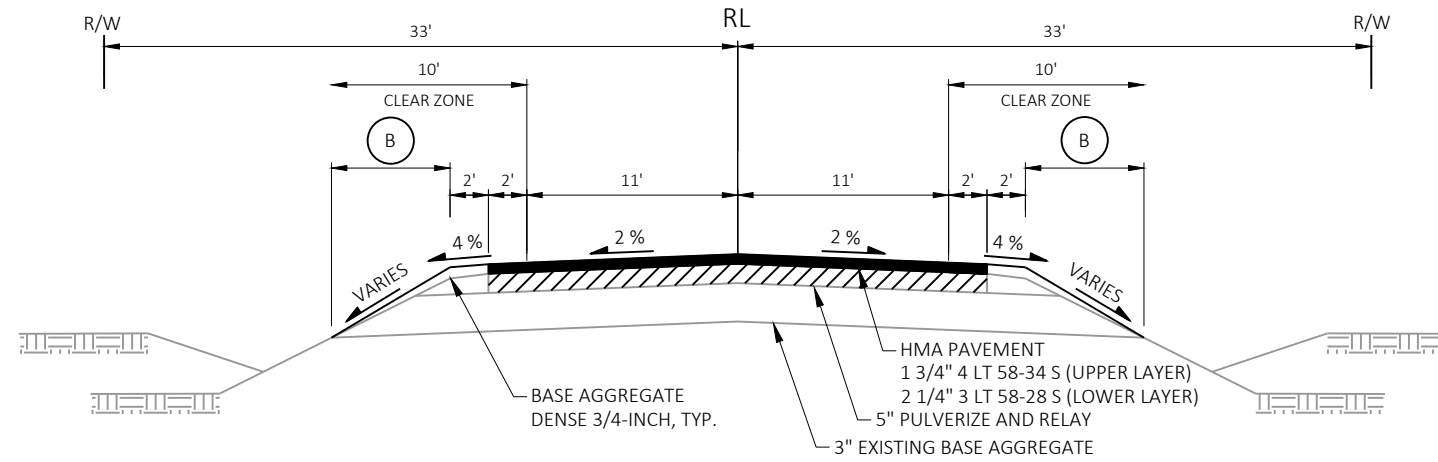

FINISHED TYPICAL SECTION - CTH D

STA 9+73.36 - 112+50
STA 118+00 - 198+50

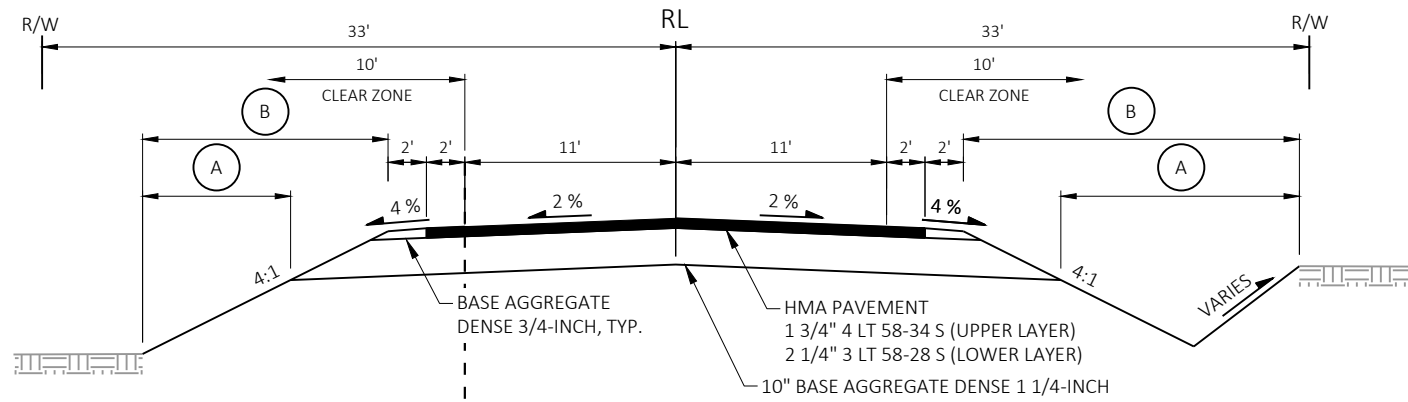

FINISHED TYPICAL SECTION - CTH D

STA 112+50 - 118+00
STA 198+50 - 204+98

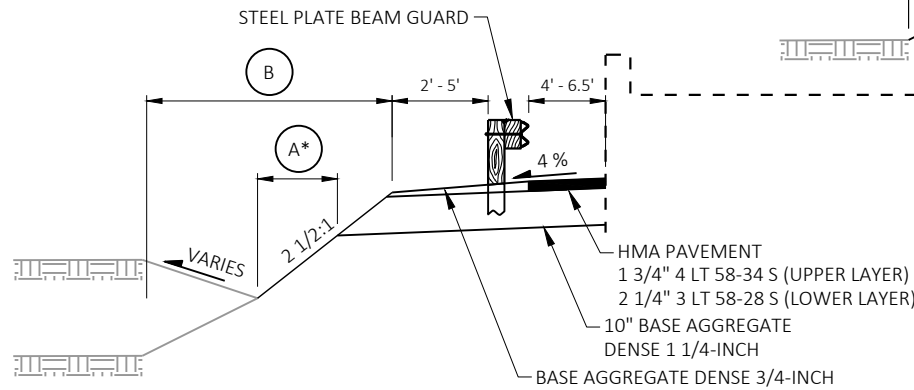

FINISHED TYPICAL BEAMGUARD SECTION - CTH D

STA 202+79.90 - 204+98

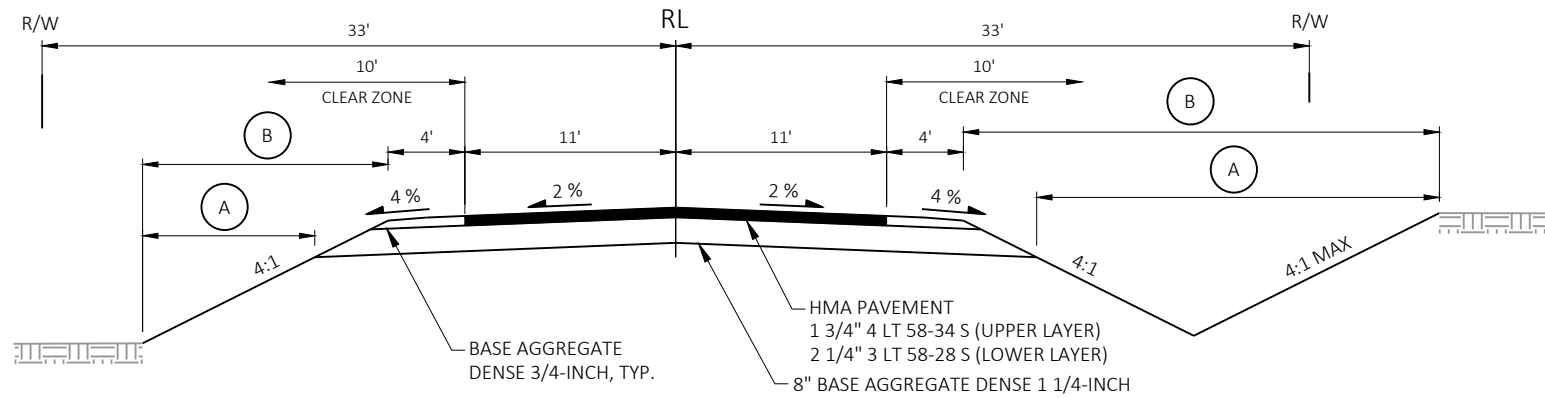

FINISHED TYPICAL SECTION - LUDINGTON DRIVE

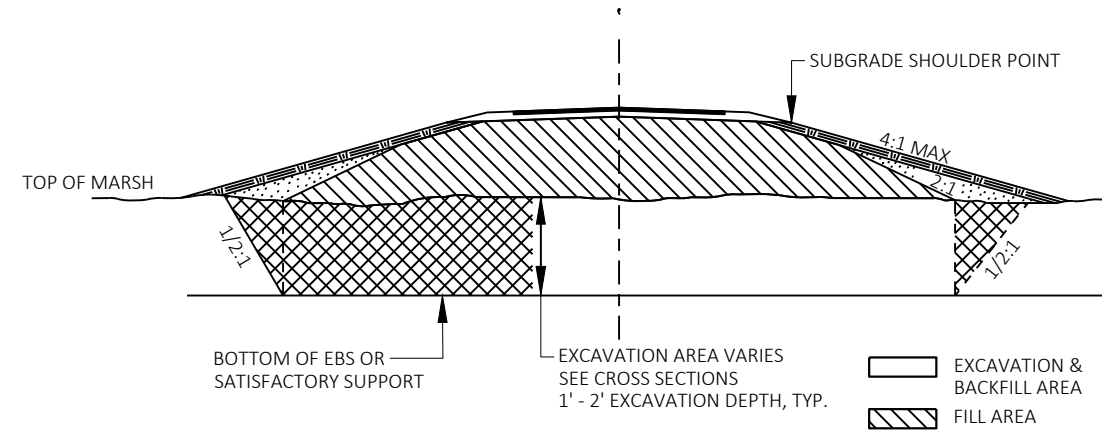

STA 300+00 - 301+65

- (A) SALVAGED TOPSOIL & MULCH
- (A*) SALVAGED TOPSOIL & EROSION MAT CLASS I TYPE B
- (B) SEEDING MIXTURE NO. 20 & FERTILIZER TYPE B

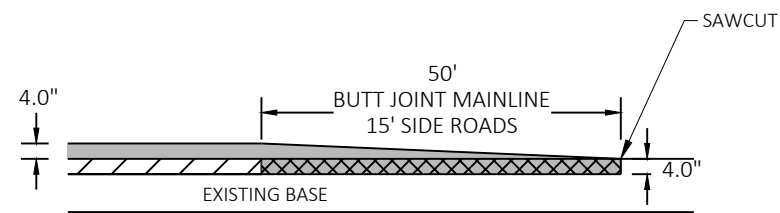

TYPICAL EXCAVATION BELOW SUBGRADE SECTION



-  HMA PAVEMENT
-  PULVERIZE AND RELAY
-  REMOVING ASPHALTIC SURFACE BUTT JOINTS

BUTT JOINT

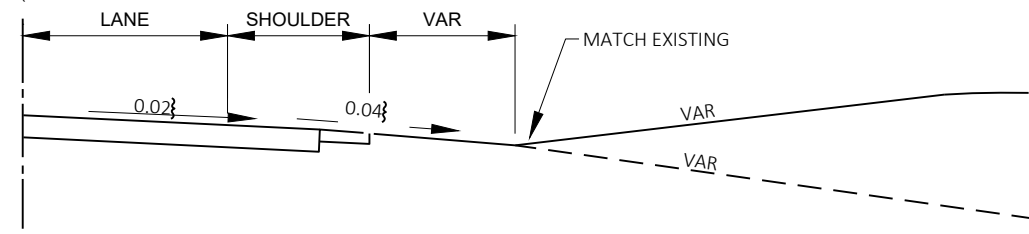

TYPICAL PROFILE VIEW

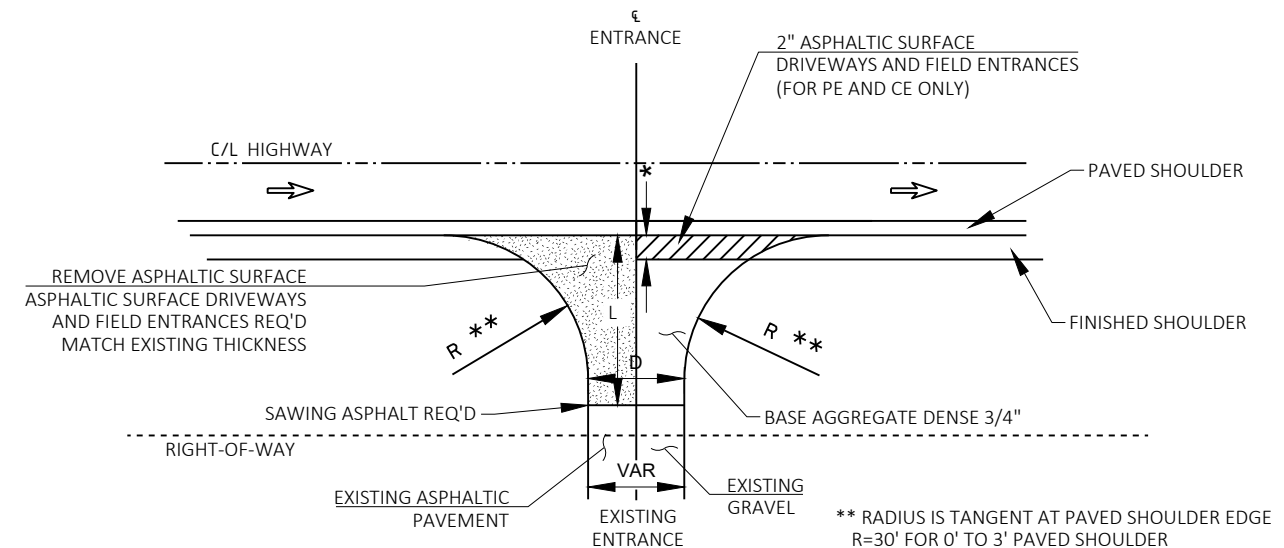

L=VARIABLE, EXACT LENGTH TO BE DETERMINED IN THE FIELD BY THE ENGINEER

D=DRIVEWAY WIDTH
 D=20'TYP(PE & FE) (16'MIN-24'MAX)
 D=28'TYP(CE & FARM ENT) (24'MIN-35'MAX)

** RADIUS IS TANGENT AT PAVED SHOULDER EDGE
 R=30' FOR 0' TO 3' PAVED SHOULDER
 R=25' FOR GREATER THAN 3' PAVED SHOULDER

* 3' MIN OR TO FINISHED SHOULDER WHICH EVER IS GREATER

PLAN VIEW

RURAL DRIVEWAY INTERSECTION (PE, FE & CE)

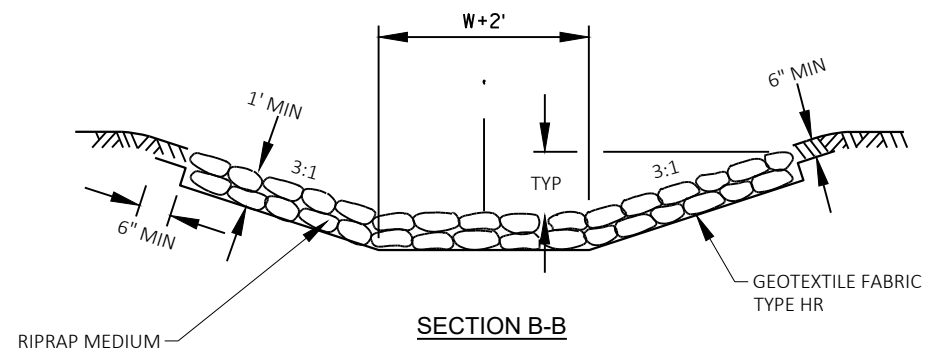
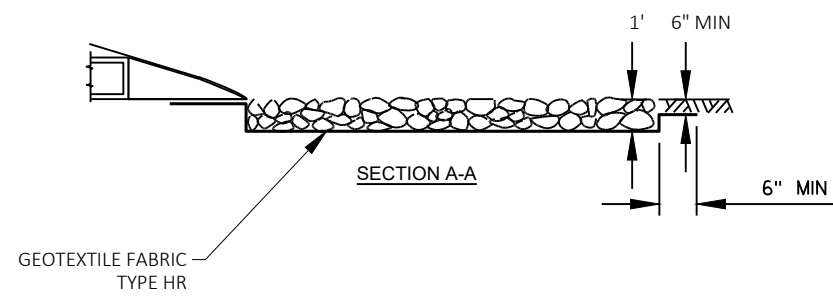
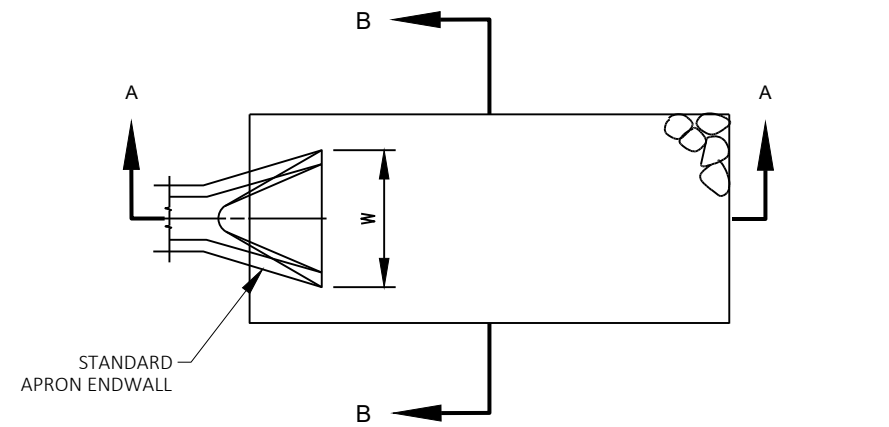

RIP RAP AND GEOTEXTILE

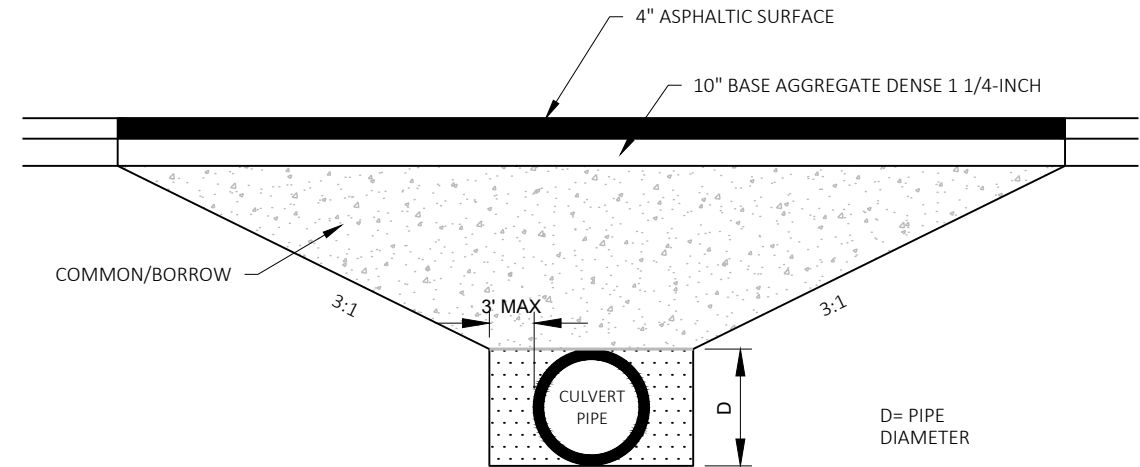

CULVERT PIPE BACKFILL DETAIL

*PLACE ASPHALTIC SURFACE
PRIOR TO PULVERIZING

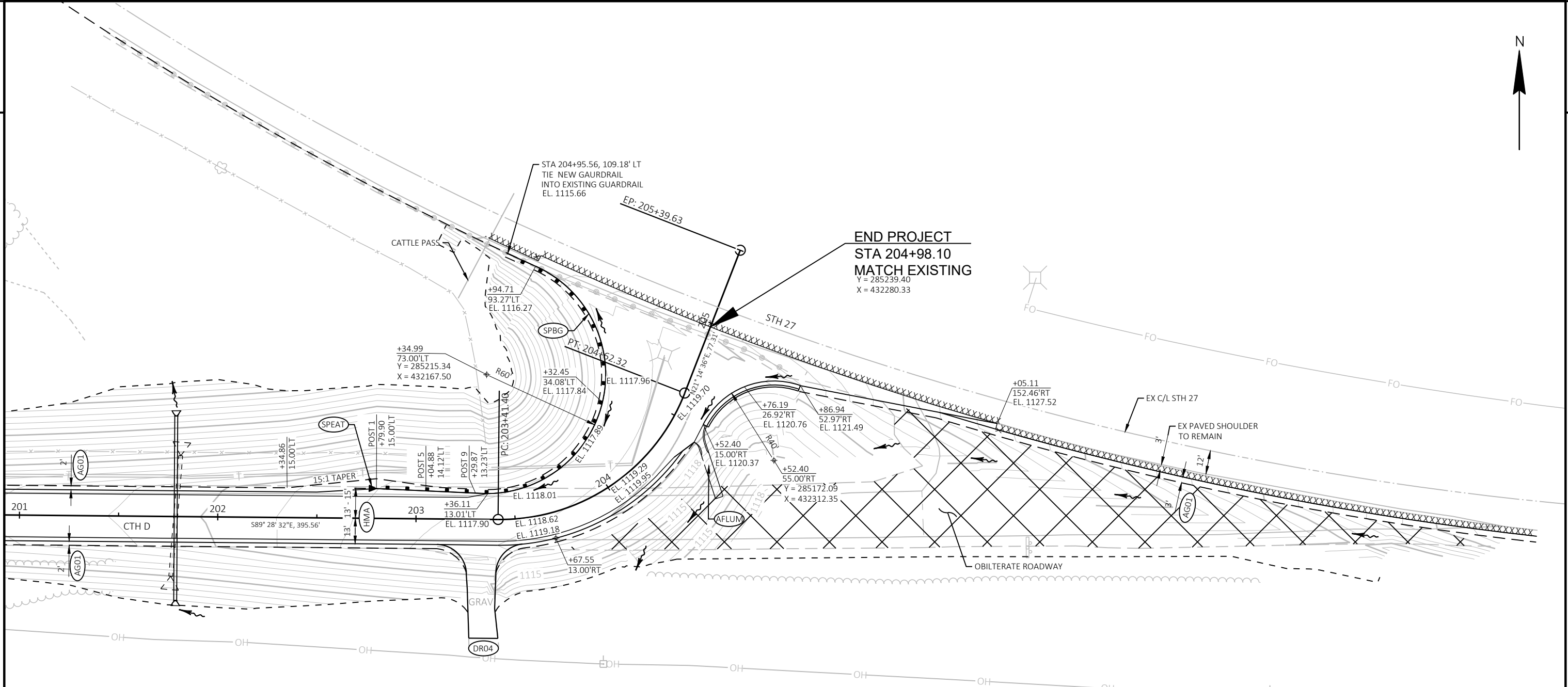

END PROJECT
STA 204+98.10
MATCH EXISTING
 Y = 285239.40
 X = 432280.33

PI STA = 204+10.49
 Y = 285141.656
 X = 432242.328
 DELTA = 69°16'53"
 D = 57°17'45"
 T = 69.09'
 L = 120.92'
 R = 100.00'
 PC STA = 203+41.40
 PT STA = 204+62.32
 SE 6.0%

- LEGEND**
- (AG01) BASE AGGREGATE DENSE 3/4-INCH
 - (CG36) CONCRETE CURB & GUTTER 6-INCH SLOPED 36-INCH TYPE D
 - (DR02) ASPHALTIC SURFACE DRIVEWAY AND FIELD ENTRANCE, 2 - INCH BUTT JOINT
 - (DR04) AGGREGATE DRIVEWAY, BASE AGGREGATE DENSE 3/4 - INCH, 6 - INCH
 - (HMA) HMA PAVEMENT
 - (HMA2) 5" PULVERIZE AND RELAY, OVERLAY 4" HMA PAVEMENT
 - (SPEAT) STEEL PLATE BEAM GUARD ENERGY ABSORBING TERMINAL
 - (SPBG) STEEL PLATE BEAM GUARD CLASS A
 - (AFLUM) ASPHALT FLUMES
 - XXXXXX SAWING ASPHALT

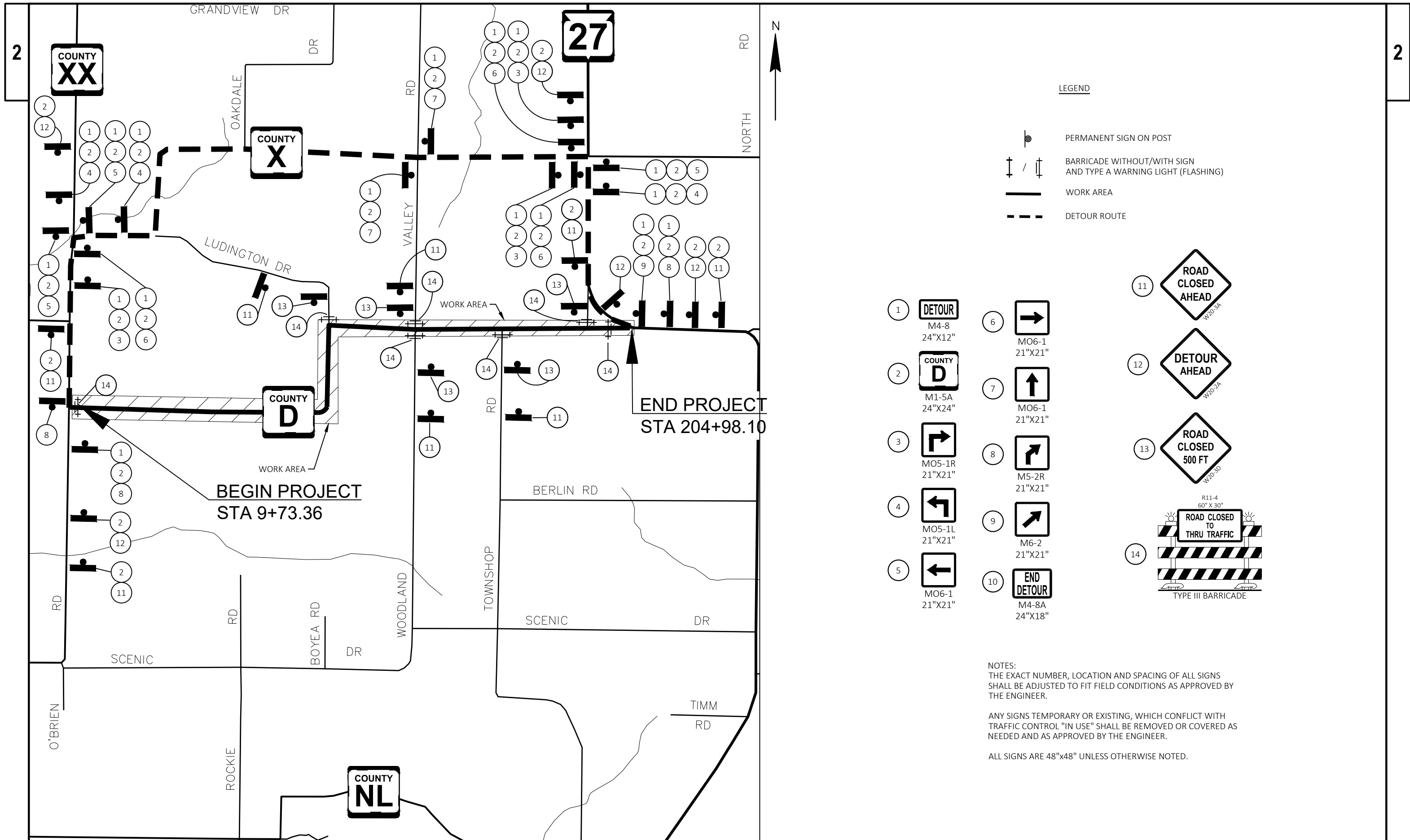

LEGEND

- PERMANENT SIGN ON POST
- BARRICADE WITHOUT/WITH SIGN AND TYPE A WARNING LIGHT (FLASHING)
- WORK AREA
- DETOUR ROUTE

- 1 **DETOUR**
M4-8
24"x12"
- 2 **COUNTY D**
M1-5A
24"x24"
- 3 M05-1R
21"x21"
- 4 M05-1L
21"x21"
- 5 M06-1
21"x21"
- 6 M06-1
21"x21"
- 7 M06-1
21"x21"
- 8 M5-2R
21"x21"
- 9 M6-2
21"x21"
- 10 **END DETOUR**
M4-8A
24"x18"

- 11 **ROAD CLOSED AHEAD**
W20-3A
- 12 **DETOUR AHEAD**
W20-2A
- 13 **ROAD CLOSED 500 FT**
W20-3D
- 14 **ROAD CLOSED TO THRU TRAFFIC**
R11-4
60" X 30"
TYPE III BARRICADE

NOTES:
 THE EXACT NUMBER, LOCATION AND SPACING OF ALL SIGNS SHALL BE ADJUSTED TO FIT FIELD CONDITIONS AS APPROVED BY THE ENGINEER.
 ANY SIGNS TEMPORARY OR EXISTING, WHICH CONFLICT WITH TRAFFIC CONTROL "IN USE" SHALL BE REMOVED OR COVERED AS NEEDED AND AS APPROVED BY THE ENGINEER.
 ALL SIGNS ARE 48"x48" UNLESS OTHERWISE NOTED.

BEGIN PROJECT
STA 9+73.36

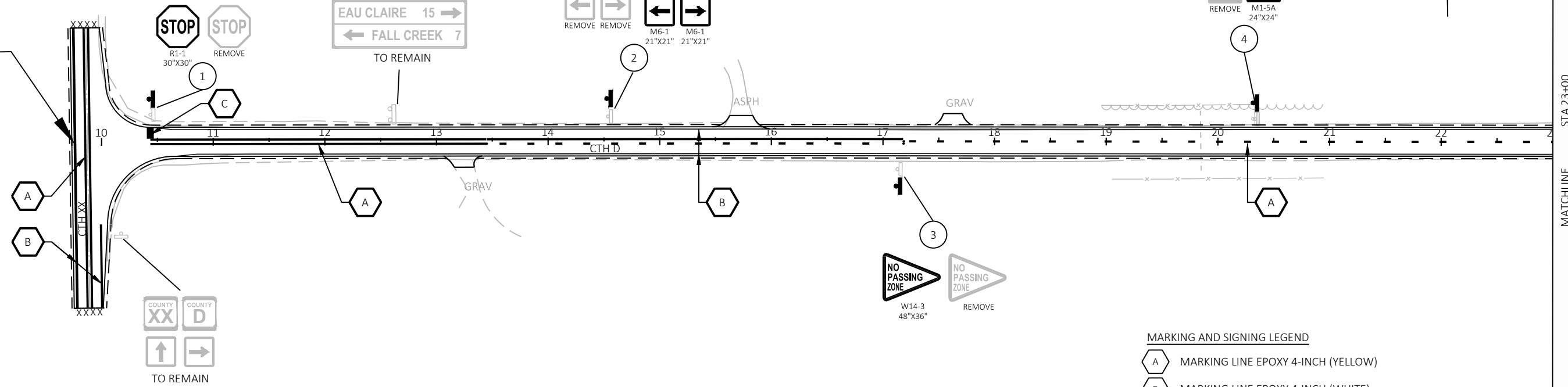

MARKING AND SIGNING LEGEND

- MARKING LINE EPOXY 4-INCH (YELLOW)
- MARKING LINE EPOXY 4-INCH (WHITE)
- MARKING STOP LINE EPOXY 18-INCH
- EXISTING SIGN MOUNTED ON POST(S)
- PROPOSED SIGN MOUNTED ON POST(S)
- DENOTES SIGN NUMBER



MATCHLINE
STA 23+00



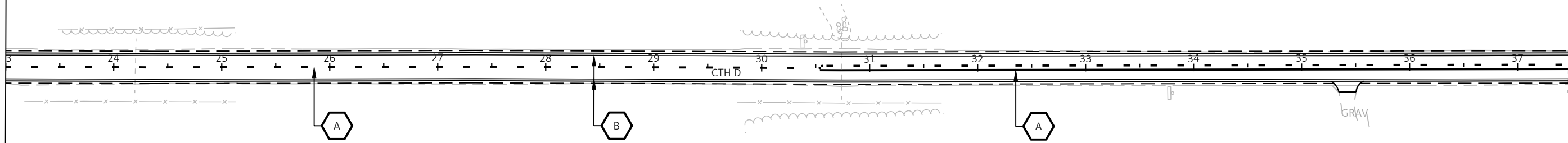



MATCHLINE
STA 37+50

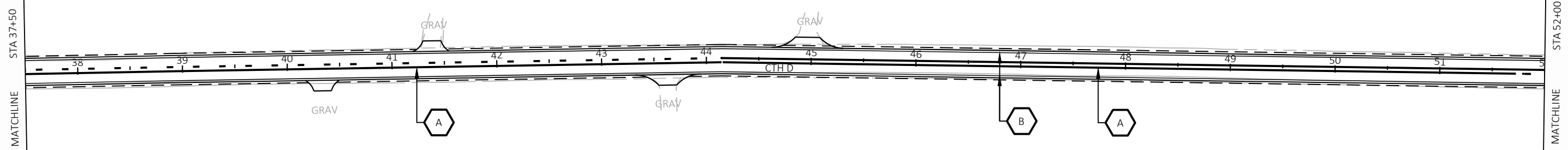

2

2



- MARKING AND SIGNING LEGEND**
-  MARKING LINE EPOXY 4-INCH (YELLOW)
 -  MARKING LINE EPOXY 4-INCH (WHITE)
 -  MARKING STOP LINE EPOXY 18-INCH
 -  EXISTING SIGN MOUNTED ON POST(S)
 -  PROPOSED SIGN MOUNTED ON POST(S)
 -  DENOTES SIGN NUMBER

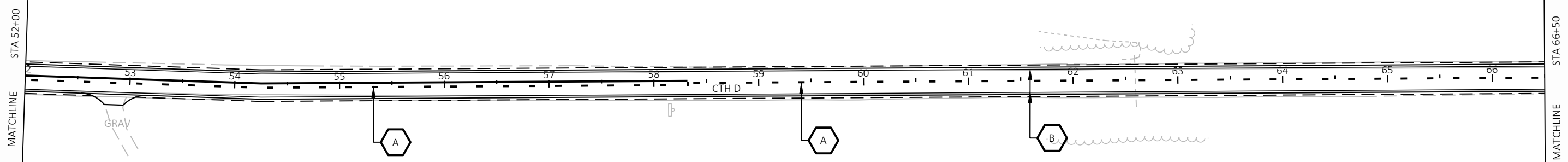



STA 66+50
MATCHLINE

STA 81+50
MATCHLINE

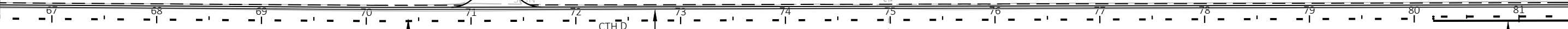

- MARKING AND SIGNING LEGEND**
- MARKING LINE EPOXY 4-INCH (YELLOW)
 - MARKING LINE EPOXY 4-INCH (WHITE)
 - MARKING STOP LINE EPOXY 18-INCH
 - EXISTING SIGN MOUNTED ON POST(S)
 - PROPOSED SIGN MOUNTED ON POST(S)
 - DENOTES SIGN NUMBER

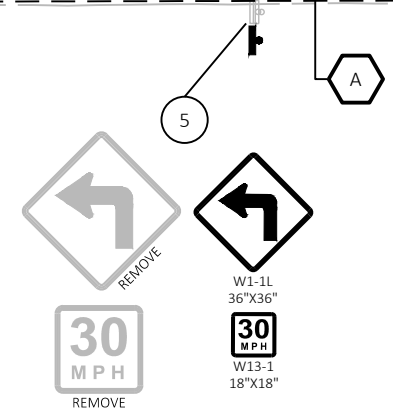

MATCHLINE
STA 81+50

MATCHLINE
STA 95+00

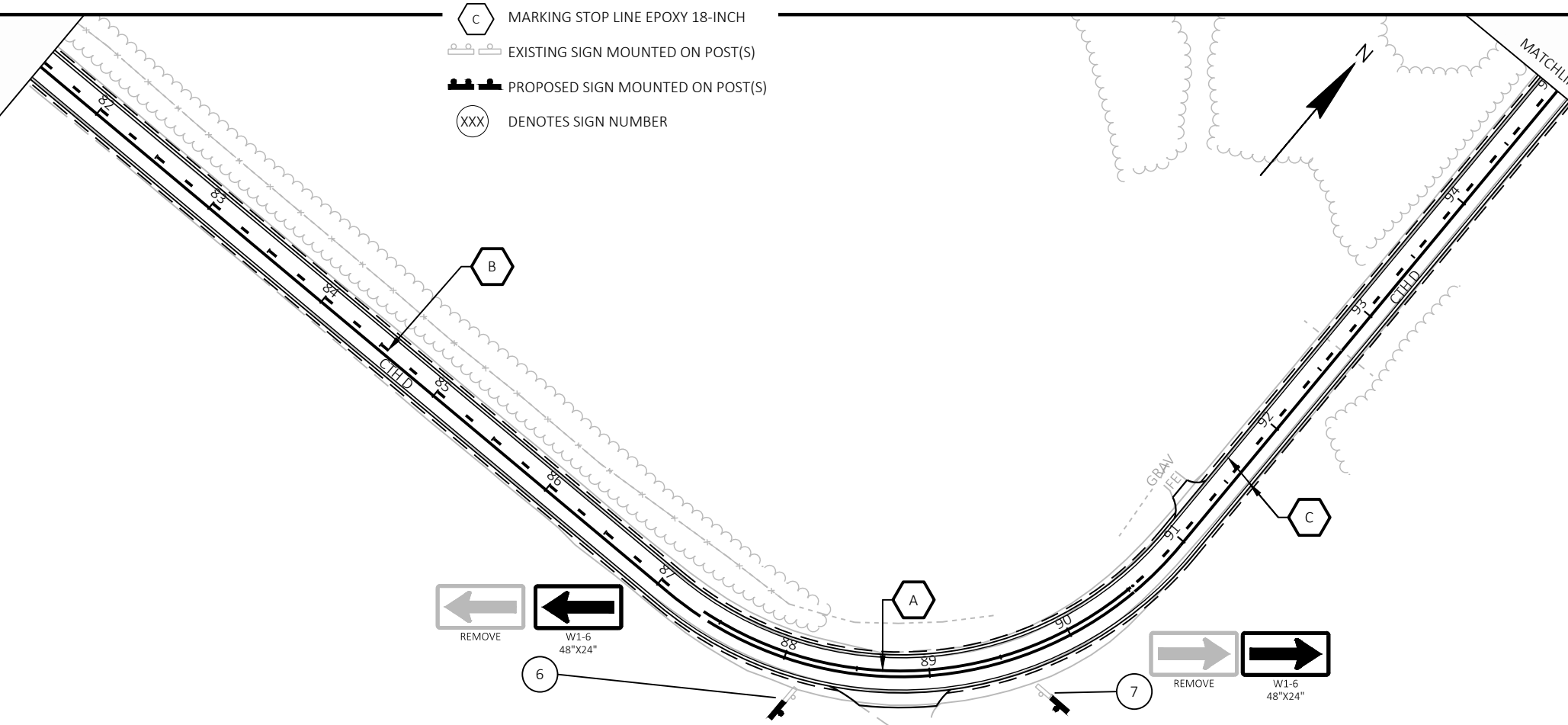
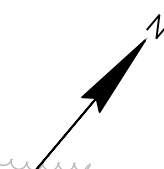

6

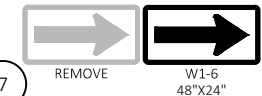

7

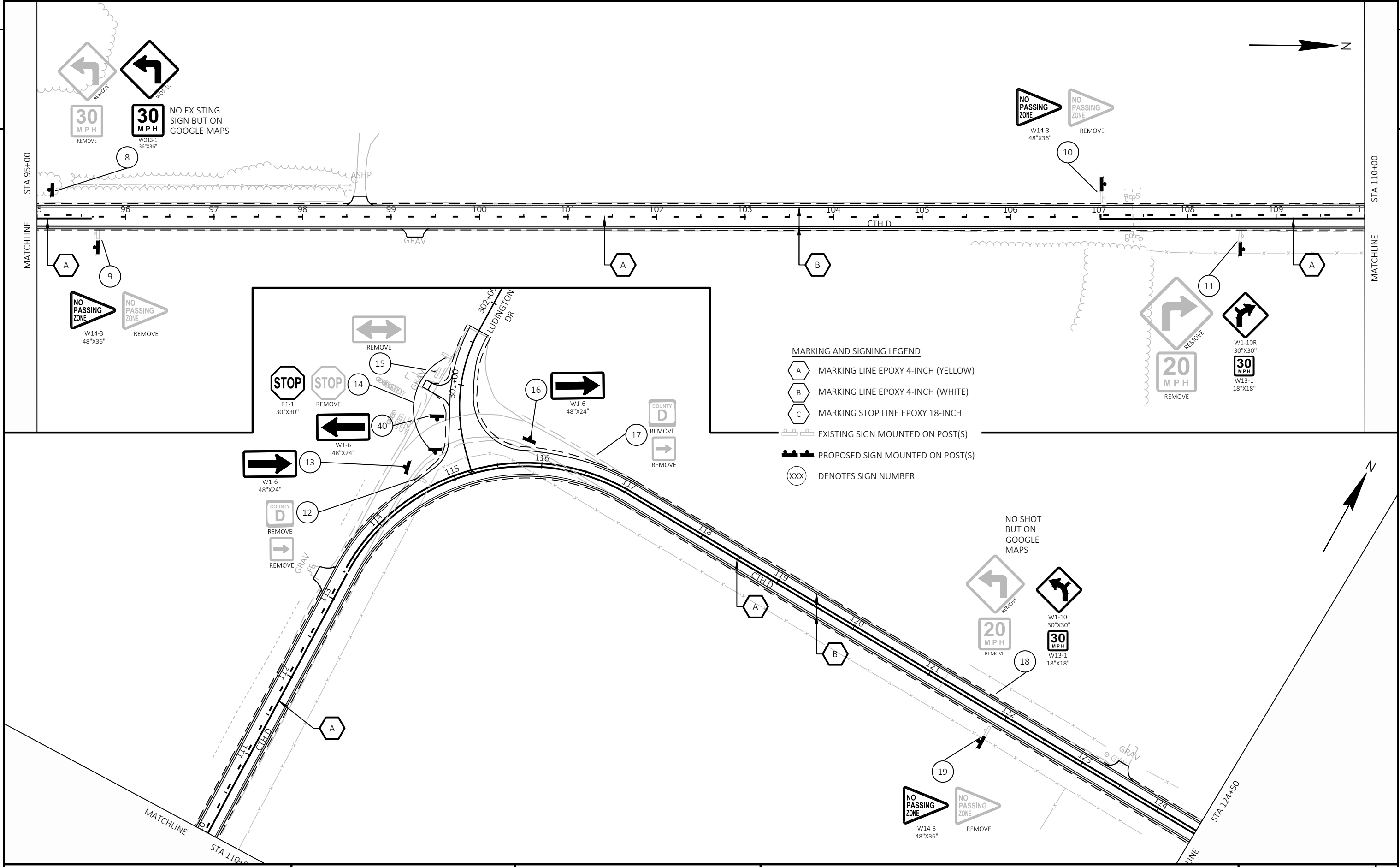

MARKING AND SIGNING LEGEND

- (A) MARKING LINE EPOXY 4-INCH (YELLOW)
- (B) MARKING LINE EPOXY 4-INCH (WHITE)
- (C) MARKING STOP LINE EPOXY 18-INCH
- EXISTING SIGN MOUNTED ON POST(S)
- PROPOSED SIGN MOUNTED ON POST(S)
- (XXX) DENOTES SIGN NUMBER

MATCHLINE STA 124+50

MATCHLINE STA 139+00

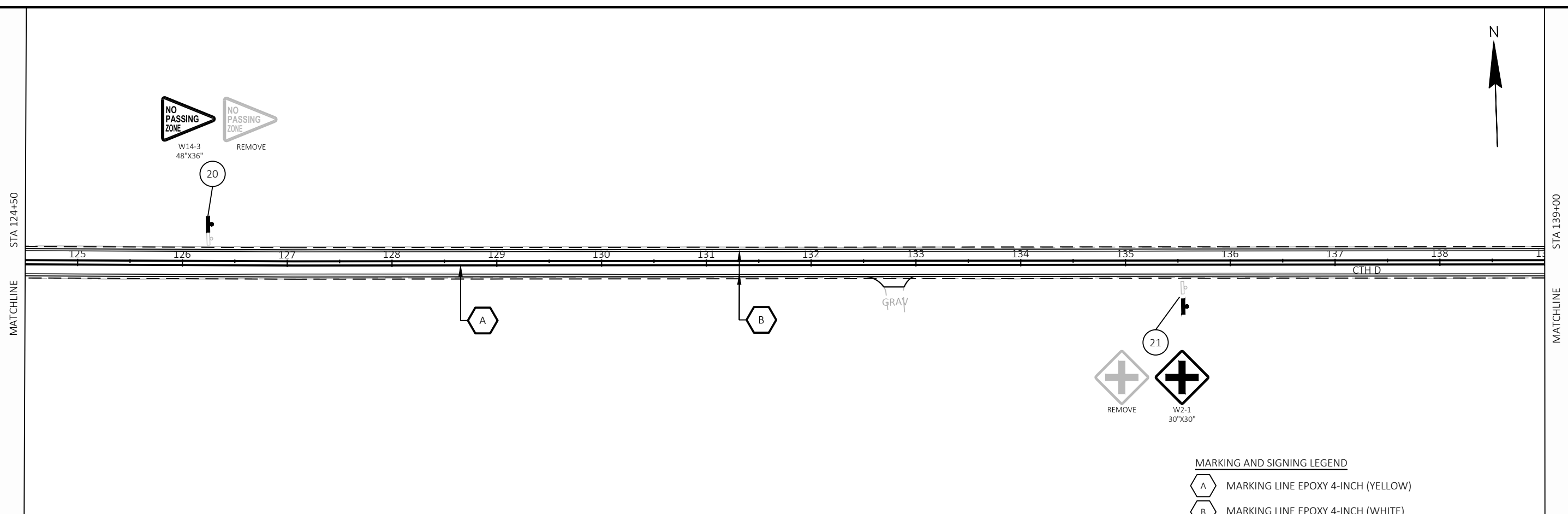

- MARKING AND SIGNING LEGEND**
- MARKING LINE EPOXY 4-INCH (YELLOW)
 - MARKING LINE EPOXY 4-INCH (WHITE)
 - MARKING STOP LINE EPOXY 18-INCH
 - EXISTING SIGN MOUNTED ON POST(S)
 - PROPOSED SIGN MOUNTED ON POST(S)
 - DENOTES SIGN NUMBER

MATCHLINE STA 139+00

MATCHLINE STA 153+50

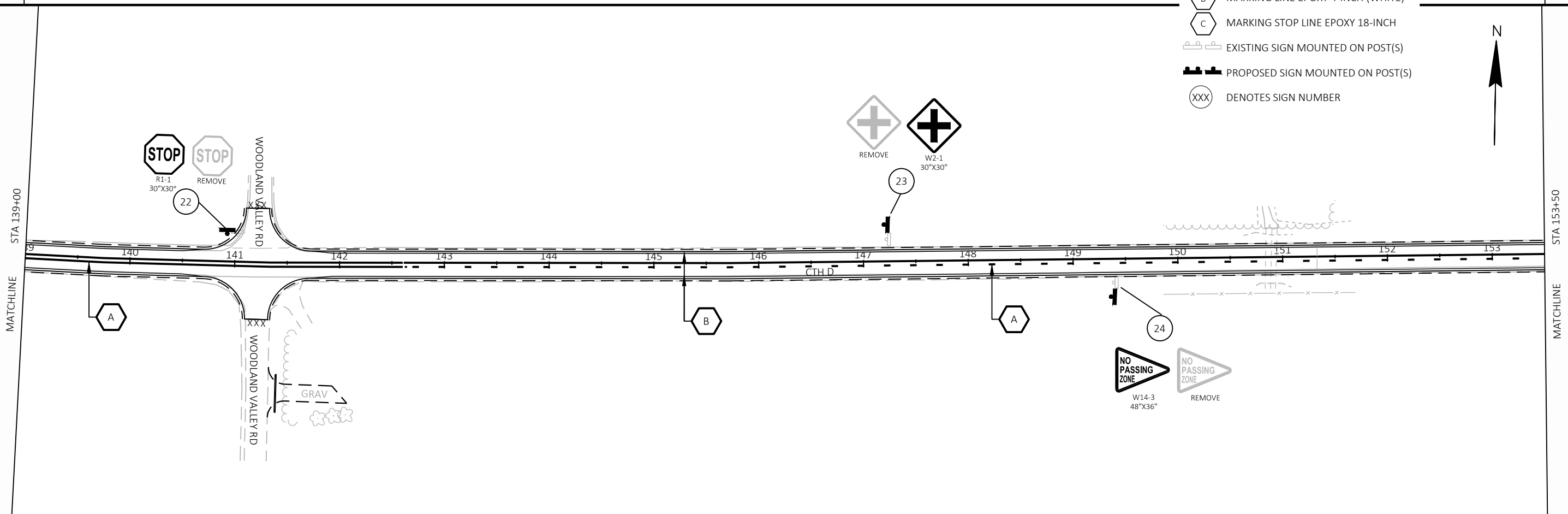

STA 153+50
MATCHLINE

STA 168+00
MATCHLINE

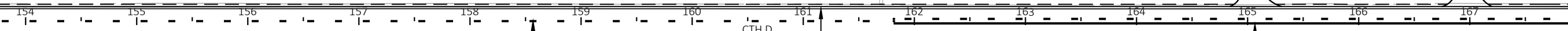

- MARKING AND SIGNING LEGEND**
- MARKING LINE EPOXY 4-INCH (YELLOW)
 - MARKING LINE EPOXY 4-INCH (WHITE)
 - MARKING STOP LINE EPOXY 18-INCH
 - EXISTING SIGN MOUNTED ON POST(S)
 - PROPOSED SIGN MOUNTED ON POST(S)
 - DENOTES SIGN NUMBER

STA 168+00
MATCHLINE

STA 182+50
MATCHLINE



STA 182+50
MATCHLINE

STA 197+00
MATCHLINE

- MARKING AND SIGNING LEGEND**
- MARKING LINE EPOXY 4-INCH (YELLOW)
 - MARKING LINE EPOXY 4-INCH (WHITE)
 - MARKING STOP LINE EPOXY 18-INCH
 - EXISTING SIGN MOUNTED ON POST(S)
 - PROPOSED SIGN MOUNTED ON POST(S)
 - DENOTES SIGN NUMBER



30

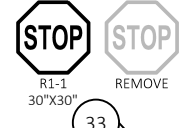

33

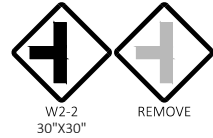

31



32

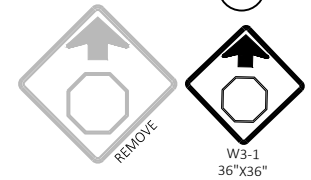

34

STA 197+00
MATCHLINE

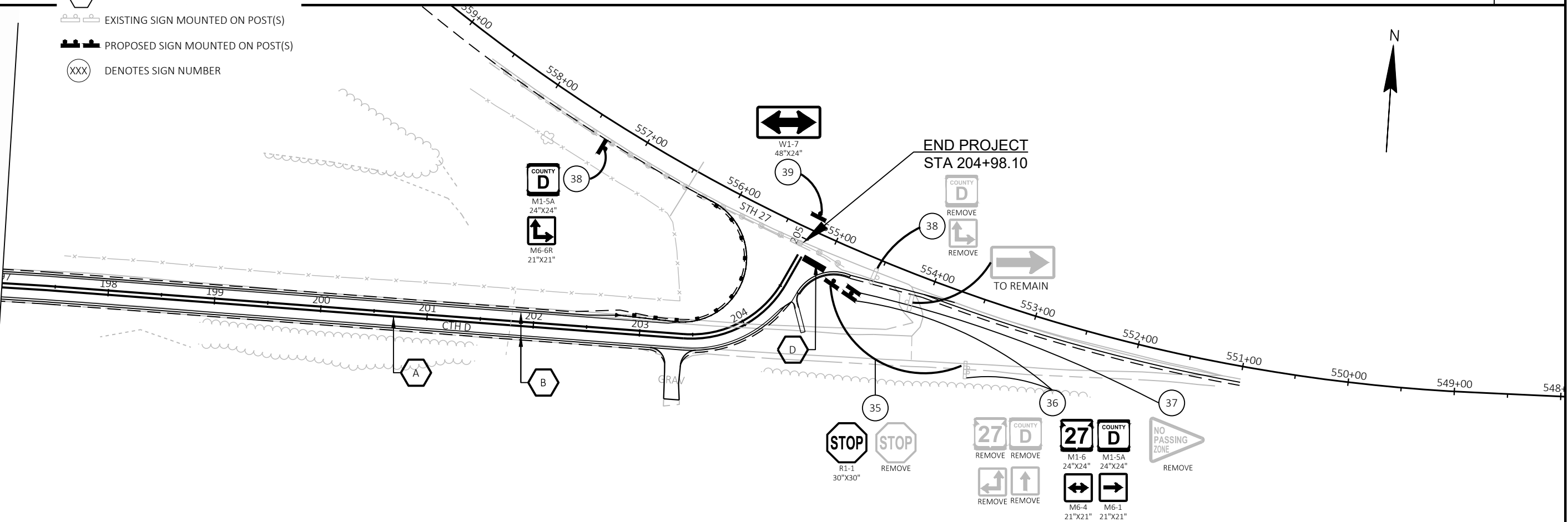

Estimate Of Quantities

7823-07-73

Line	Item	Item Description	Unit	Total	Qty
0002	201.0105	Clearing	STA	0.500	0.500
0004	201.0205	Grubbing	STA	0.500	0.500
0006	203.0100	Removing Small Pipe Culverts	EACH	6.000	6.000
0008	204.0110	Removing Asphaltic Surface	SY	114.000	114.000
0010	204.0115	Removing Asphaltic Surface Butt Joints	SY	430.000	430.000
0012	204.0165	Removing Guardrail	LF	160.000	160.000
0014	205.0100	Excavation Common	CY	3,783.000	3,783.000
0016	208.0100	Borrow	CY	9,769.000	9,769.000
0018	213.0100	Finishing Roadway (project) 01. 7823-07-73	EACH	1.000	1.000
0020	214.0100	Obliterating Old Road	STA	3.700	3.700
0022	305.0110	Base Aggregate Dense 3/4-Inch	TON	9,469.000	9,469.000
0024	305.0120	Base Aggregate Dense 1 1/4-Inch	TON	1,269.000	1,269.000
0026	325.0100	Pulverize and Relay	SY	46,158.000	46,158.000
0028	455.0605	Tack Coat	GAL	4,156.000	4,156.000
0030	460.2000	Incentive Density HMA Pavement	DOL	8,510.000	8,510.000
0032	460.5223	HMA Pavement 3 LT 58-28 S	TON	7,475.000	7,475.000
0034	460.5244	HMA Pavement 4 LT 58-34 S	TON	5,816.000	5,816.000
0036	465.0105	Asphaltic Surface	TON	70.000	70.000
0038	465.0120	Asphaltic Surface Driveways and Field Entrances	TON	27.000	27.000
0040	465.0315	Asphaltic Flumes	SY	17.000	17.000
0042	521.1012	Apron Endwalls for Culvert Pipe Steel 12-Inch	EACH	2.000	2.000
0044	521.1018	Apron Endwalls for Culvert Pipe Steel 18-Inch	EACH	10.000	10.000
0046	521.1024	Apron Endwalls for Culvert Pipe Steel 24-Inch	EACH	2.000	2.000
0048	530.0112	Culvert Pipe Corrugated Polyethylene 12-Inch	LF	36.000	36.000
0050	530.0118	Culvert Pipe Corrugated Polyethylene 18-Inch	LF	298.000	298.000
0052	530.0124	Culvert Pipe Corrugated Polyethylene 24-Inch	LF	59.000	59.000
0054	601.0557	Concrete Curb & Gutter 6-Inch Sloped 36-Inch Type D	LF	48.000	48.000
0056	606.0200	Riprap Medium	CY	3.000	3.000
0058	614.0305	Steel Plate Beam Guard Class A	LF	192.000	192.000
0060	614.0370	Steel Plate Beam Guard Energy Absorbing Terminal	EACH	1.000	1.000
0062	618.0100	Maintenance And Repair of Haul Roads (project) 01. 7823-07-73	EACH	1.000	1.000
0064	619.1000	Mobilization	EACH	1.000	1.000
0066	624.0100	Water	MGAL	225.000	225.000
0068	625.0500	Salvaged Topsoil	SY	9,665.000	9,665.000
0070	627.0200	Mulching	SY	8,690.000	8,690.000
0072	628.1504	Silt Fence	LF	820.000	820.000
0074	628.1520	Silt Fence Maintenance	LF	820.000	820.000
0076	628.1905	Mobilizations Erosion Control	EACH	4.000	4.000
0078	628.1910	Mobilizations Emergency Erosion Control	EACH	2.000	2.000
0080	628.2004	Erosion Mat Class I Type B	SY	975.000	975.000
0082	628.7555	Culvert Pipe Checks	EACH	7.000	7.000
0084	629.0210	Fertilizer Type B	CWT	20.910	20.910
0086	630.0120	Seeding Mixture No. 20	LB	850.000	850.000
0088	630.0140	Seeding Mixture No. 40	LB	4.000	4.000
0090	630.0500	Seed Water	MGAL	709.000	709.000
0092	633.5200	Markers Culvert End	EACH	12.000	12.000
0094	634.0614	Posts Wood 4x6-Inch X 14-FT	EACH	39.000	39.000
0096	637.2210	Signs Type II Reflective H	SF	102.760	102.760
0098	637.2230	Signs Type II Reflective F	SF	227.600	227.600

Estimate Of Quantities

7823-07-73

Line	Item	Item Description	Unit	Total	Qty
0100	638.2602	Removing Signs Type II	EACH	50.000	50.000
0102	638.3000	Removing Small Sign Supports	EACH	37.000	37.000
0104	642.5001	Field Office Type B	EACH	1.000	1.000
0106	643.0300	Traffic Control Drums	DAY	3,500.000	3,500.000
0108	643.0420	Traffic Control Barricades Type III	DAY	490.000	490.000
0110	643.0705	Traffic Control Warning Lights Type A	DAY	980.000	980.000
0112	643.0900	Traffic Control Signs	DAY	5,810.000	5,810.000
0114	643.0920	Traffic Control Covering Signs Type II	EACH	4.000	4.000
0116	643.5000	Traffic Control	EACH	1.000	1.000
0118	645.0120	Geotextile Type HR	SY	9.000	9.000
0120	646.1020	Marking Line Epoxy 4-Inch	LF	58,766.000	58,766.000
0122	646.6120	Marking Stop Line Epoxy 18-Inch	LF	43.000	43.000
0124	648.0100	Locating No-Passing Zones	MI	3.700	3.700
0126	650.4500	Construction Staking Subgrade	LF	1,363.000	1,363.000
0128	650.5000	Construction Staking Base	LF	1,363.000	1,363.000
0130	650.5500	Construction Staking Curb Gutter and Curb & Gutter	LF	48.000	48.000
0132	650.6000	Construction Staking Pipe Culverts	EACH	7.000	7.000
0134	650.8000	Construction Staking Resurfacing Reference	LF	18,327.000	18,327.000
0136	650.9910	Construction Staking Supplemental Control (project) 01. 7823-07-73	LS	1.000	1.000
0138	650.9920	Construction Staking Slope Stakes	LF	1,363.000	1,363.000
0140	690.0150	Sawing Asphalt	LF	790.000	790.000
0142	740.0440	Incentive IRI Ride	DOL	14,792.000	14,792.000
0144	ASP.1T0A	On-the-Job Training Apprentice at \$5.00/HR	HRS	300.000	300.000
0146	ASP.1T0G	On-the-Job Training Graduate at \$5.00/HR	HRS	300.000	300.000

3

DIVISION	FROM/TO STATION	LOCATION	205.0100 COMMON EXCAVATION (1)		SALVAGED/UNUSABLE PAVEMENT MATERIAL (4)	AVAILABLE MATERIAL (5)	REDUCED EBS IN FILL (6)	UNEXPANDED FILL	EXPANDED FILL (7)	MASS ORDINATE +/- (8)	208.0100 BORROW
			CUT (2)	EBS EXCAVATION (3)			FACTOR 0.80		FACTOR 1.25		
DIVISION 1											
CTH D - CULVERTS/RECONSTRUCTION	19+65/204+75		1,282	1,286	153	1,129	1,029	9,523	11,904	-9,746	9,746
DIVISION 1 SUBTOTAL			1,282	1,286	153	1,129	1,029	9,523	11,904	-9,746	
GRAND TOTAL			1,282	1,286	153	1,129	1,029	9,523	11,904	-9,746	9,746
TOTAL COMMON EXC			2,568								

3

DIVISION	FROM/TO STATION	LOCATION	205.0100 COMMON EXCAVATION	SALVAGED/UNUSABLE PAVEMENT MATERIAL (4)	AVAILABLE MATERIAL (5)	UNEXPANDED FILL	EXPANDED FILL (7)	MASS ORDINATE +/- (8)	WASTE
			CUT (2)				FACTOR 1.00		
DIVISION 1									
STH 27	551+20.845/556+68.889		514	0	514	180	180	334	334
DIVISION 1 SUBTOTAL			514	0	514	180	180	334	334
GRAND TOTAL			514	0	514	180	180	334	334
TOTAL COMMON EXC			514						

DIVISION	FROM/TO STATION	LOCATION	205.0100 COMMON EXCAVATION (1)		SALVAGED/UNUSABLE PAVEMENT MATERIAL (4)	AVAILABLE MATERIAL (5)	REDUCED EBS IN FILL (6)	UNEXPANDED FILL	EXPANDED FILL (7)	MASS ORDINATE +/- (8)	WASTE	208.0100 BORROW
			CUT (2)	EBS EXCAVATION (3)			FACTOR 0.80		FACTOR 1.25			
DIVISION 1												
LUDINGTON	300+50/301+63.5		133	68	28	105	54	102	128	-23	54	23
DIVISION 1 SUBTOTAL			133	68	28	105	54	102	128	-23		
GRAND TOTAL			133	68	28	105	54	102	128	-23	54	23
TOTAL COMMON EXC			201									

NOTES:

- (1) COMMON EXCAVATION IS THE SUM OF THE CUT AND EBS EXCAVATION COLUMNS. ITEM NUMBER 205.0100
- (2) SALVAGED/UNUSABLE PAVEMENT MATERIAL IS INCLUDED IN CUT.
- (3) EBS EXCAVATION TO BE BACKFILLED WITH COMMON OR BORROW MATERIAL.
- (4) SALVAGED/UNUSABLE PAVEMENT MATERIAL
- (5) AVAILABLE MATERIAL = CUT - SALVAGED/UNUSABLE PAVEMENT MATERIAL
- (6) REDUCED EBS IN FILL - EXCAVATED EBS MATERIAL IS USABLE IN FILLS OUTSIDE OF THE ROADWAY FOUNDATION. EBS IN FILL REDUCTION FACTOR = 0.80
- (7) EXPANDED FILL FACTOR = 1.25
- (8) THE MASS ORDINATE + OR - QTY CALCULATED FOR THE DIVISION. PLUS QUANTITY INDICATES AN EXCESS OF MATERIAL WITHIN THE DIVISION. MINUS INDICATES A SHORTAGE OF MATERIAL WITHIN THE DIVISION.

3

3

LOCATION	203.0100 REMOVING SMALL PIPE CULVERTS EACH	521.1012 APRON ENDWALLS FOR CULVERT PIPE STEEL 12-INCH EACH	521.1018 APRON ENDWALLS EOR CULVERT PIPE STEEL 18-INCH EACH	521.1024 APRON ENDWALLS EOR CULVERT PIPE STEEL 24-INCH EACH	530.0112 CULVERT PIPE CORRUGATED POLYETHYLENE 12-INCH LF	530.0118 CULVERT PIPE CORRUGATED POLYETHYLENE 18-INCH LF	530.0124 CULVERT PIPE CORRUGATED POLYETHYLENE 24-INCH LF	628.7555 CULVERT PIPE CHECKS EACH	633.5200 MARKERS CULVERT END EACH	650.6000 CONSTRUCTION STAKING PIPE CULVERTS EACH
19+85	1	-	-	2	-	-	59	1	2	1
24+20	1	-	2	-	-	51	-	1	2	1
62+59	1	-	2	-	-	46	-	1	2	1
141+34	-	2	-	-	36	-	-	1	-	1
173+87	1	-	2	-	-	54	-	1	2	1
179+27	1	-	2	-	-	54	-	1	2	1
201+79	1	-	2	-	-	93	-	1	2	1
TOTAL 0010	6	2	10	2	36	298	59	7	12	7

STATION	LOCATION	204.0110 REMOVING ASPHALTIC SURFACE SY	204.0115 REMOVING ASPHALTIC SURFACE BUTT JOINTS SY	REMARKS
9+73	CTH XX	-	250	50' BUTT JOINTS
15+73	LT	35	-	
88+92	RT	25	-	
98+65	LT	21	-	
113+17	LT	33	-	
141+22	WOODLAND VALLEY, LT	-	45	15' BUTT JOINTS
141+22	WOODLAND VALLEY, RT	-	45	15' BUTT JOINTS
167+58	TOWN SHOP RD	-	45	15' BUTT JOINTS
194+10	MINI RD	-	45	15' BUTT JOINTS
TOTAL 0010		114	430	

STATION	LOCATION	201.0105 CLEARING STA	201.0205 GRUBBING STA
141+34	DRIVEWAY	0.5	0.5
TOTAL 0010		0.5	0.5

STATION	TO	STATION	LOCATION	305.0110 BASE AGGREGATE DENSE 3/4-INCH TON	305.0120 BASE AGGREGATE DENSE 1 1/4- INCH TON	455.0605 TACK COAT GAL	460.5223 HMA PAVEMENT 3 LT 58-28 S TON	460.5244 HMA PAVEMENT 4 LT 58-34 S TON	465.0105 ASPHALTIC SURFACE TON	624.0100 WATER MGAL
9+73	-	11+00	CTH XX	147	-	85	155	120	-	-
11+00	-	112+50	ML	4,784	-	2,055	3,695	2,875	-	-
112+50	-	118+00	LUDINGTON DR	259	887	155	275	215	-	180
118+00	-	203+42	ML	4,026	-	1,730	3,115	2,420	-	-
203+42	-	204+80	STH 27 INTERSECTION	65	222	80	145	115	-	45
140+70	-	141+66	WOODLAND VALLEY	45	-	25	45	35	-	-
167+07	-	168+09	TOWN SHOP RD	48	-	13	23	18	-	-
193+58	-	194+60	MINI RD	48	-	13	22	18	-	-
-	-	-	CULVERT PIPES	-	160	-	-	-	70	-
-	-	-	141+34 RT DRIVEWAY	47	-	-	-	-	-	-
TOTAL 0010				9,469	1,269	4,156	7,475	5,816	70	225

LOCATION	204.0165 REMOVING GUARDRAIL LF	614.0305 STEEL PLATE BEAM GUARD CLASS A LF	614.0370 STEEL PLATE BEAM GUARD ENERGY ABSORBING TERMINAL EACH
STH 27 INTERSECTION	160	192	1
TOTAL 0010	160	192	1

STATION	TO	STATION	LOCATION	214.0100 OBLITERATING OLD ROAD STA
114+05	-	116+33	LUDINGTON DR	2.3
203+42	-	204+80	STH 27 INTERSECTION	1.4
TOTAL 0010				3.7

STATION	TO	STATION	LOCATION	325.0100 PULVERIZE AND RELAY SY
9+73	-	11+00	CTH XX	921
11+00	-	112+50	ML	24,811
300+38	-	301+65	LUDINGTON DR	265
141+20	-	LT	WOODLAND VALLEY	140
141+20	-	RT	WOODLAND VALLEY	128
118+00	-	198+50	ML	19,678
167+07	-	168+09	TOWN SHOP RD	100
193+58	-	194+60	MINI RD	115
TOTAL 0010				46,158

STATION	TO	STATION	LOCATION	205.0100 EXCAVATION COMMON CY	208.0100 BORROW CY
19+65	-	204+75	CTH D	2,568	9,746
551+20	-	556+69	STH 27 INTERSECTION	514	-
300+50	-	301+64	LUDINGTON DR	201	23
-	-	-	141+34 DRIVEWAY	500	-
TOTAL 0010				3,783	9,769

3

3

STATION	LOCATION	465.0120 ASPHALTIC SURFACE DRIVEWAYS AND FIELD ENTRANCES TON	690.0150 SAWING ASPHALT LF
10+00	LT & RT	-	52
15+73	LT	8	18
88+92	LT	6	18
98+65	LT	5	18
113+17	LT	8	18
115+00	LUDINGTON RD	-	26
141+22	WOODLAND VALLEY, LT	-	22
141+22	WOODLAND VALLEY, RT	-	22
167+58	TOWN SHOP RD	-	22
194+10	MINI RD	-	22
204+80	STH 27 INTERSECTION	-	552
TOTAL 0010		27	790

LOCATION	601.0557 CONCRETE CURB & GUTTER 6- INCH SLOPED 36- INCH TYPE D LF	650.5500 CONSTRUCTION STAKING CURB GUTTER AND CURB & GUTTER LF
STH 27 INTERSECTION	48	48
TOTAL 0010	48	48

STATION	LOCATION	465.0315 ASPHALTIC FLUMES SY	606.0200 RIPRAP MEDIUM CY	645.0120 GEOTEXTILE TYPE HR SY
201+79	LT	-	3	9
204+50	RT	17	-	-
TOTAL 0010		17	3	9

STATION TO	STATION	LOCATION	625.0500 SALVAGED TOPSOIL SY	627.0200 MULCHING SY	628.2004 EROSION MAT CLASS I TYPE B SY	629.0210 FERTILIZER TYPE B CWT	630.0120 SEEDING MIXTURE NO. 20 LB	630.0140 SEEDING MIXTURE NO. 40 LB	630.0500 SEED WATER MGAL
9+73	- 112+50	CTH D	-	-	-	5.75	245	-	205
112+50	- 118+00	CTH D	1,160	1,160	-	1.08	45	-	40
118+00	- 198+50	CTH D	-	-	-	4.51	195	-	160
198+50	- 203+42	CTH D	2,260	2,260	-	1.74	75	-	60
203+42	- 204+98	STH 27 INTERSECTION	3,720	2,940	780	2.51	110	-	90
300+00	- 304+65	LUDINGTON DRIVE	410	410	-	0.21	10	-	10
	141+34 RT	DRIVEWAY	180	180	-	0.11	-	3	4
		UNDISTRIBUTED (25%)	1,935	1,740	195	5	170	1	140
TOTAL 0010			9,665	8,690	975	20.91	850	4	709

STATION TO	STATION	LOCATION	628.1504 SILT FENCE LF	628.1520 SILT FENCE MAINTENANCE LF
114+05	- 116+33	LUDINGTON DR	420	420
203+83	- 204+80	STH 27 INTERSECTION	400	400
TOTAL 0010			820	820

STATION TO	STATION	LOCATION	648.0100 LOCATING NO- PASSING ZONES MI
9+73	- 204+98	ML	3.70
TOTAL 0010			3.70

LOCATION	628.1905 MOBILIZATIONS EROSION CONTROL EACH	628.1910 MOBILIZATIONS EMERGENCY EROSION CONTROL EACH
PROJECT	4	2
TOTAL 0010	4	2

LOCATION	643.5000 TRAFFIC CONTROL EACH
PROJECT	1
TOTAL 0010	1

LOCATION	643.0300 TRAFFIC CONTROL DRUMS DAY	643.0420 TRAFFIC CONTROL BARRICADES TYPE III DAY	643.0705 TRAFFIC CONTROL WARNING LIGHTS TYPE A DAY	643.0900 TRAFFIC CONTROL SIGNS DAY
PROJECT	50 X 70 DAYS 3,500	7 X 70 DAYS 490	14 X 70 DAYS 980	84 X 70 DAYS 5,810
TOTAL 0010	3,500	490	980	5,810

LOCATION	643.0920 TRAFFIC CONTROL COVERING SIGNS TYPE II EACH	NUMBER OF CYCLES	NUMBER OF SIGNS
PROJECT	4	1	4
TOTAL 0010	4		

STATION TO	STATION	LOCATION	650.4500 CONSTRUCTION STAKING SUBGRADE LF	650.5000 CONSTRUCTION STAKING BASE LF	650.8000 CONSTRUCTION STAKING RESURFACING REFERENCE LF	650.9910.01 CONSTRUCTION STAKING SUPPLEMENTAL CONTROL (PROJECT) (01. 7823-07-73) LS	650.9920 CONSTRUCTION STAKING SLOPE STAKES LF
9+73	- 112+50	CTH D	-	-	10,277	-	-
112+50	- 118+00	CTH D	550	550	-	-	550
118+00	- 198+50	CTH D	-	-	8,050	-	-
198+50	- 204+98	CTH D	648	648	-	-	648
300+00	- 301+65	LUDINGTON DRIVE PROJECT	165	165	-	-	165
			-	-	-	1	-
TOTAL 0010			1,363	1,363	18,327	1	1,363

PROJECT NO: 7823-07-73

HWY: CTH D

COUNTY: EAU CLAIRE

MISCELLANEOUS QUANTITIES

SHEET

E

3

3

STATION	LOCATION	SIGN NUMBER	SIGN CODE	SIGN MESSAGE	SIZE (IN)	634.0614	637.2210	637.2230	638.2602	638.3000
						POSTS WOOD 4X6-INCH X 14-FT EACH	SIGNS TYPE II REFLECTIVE H SF	SIGNS TYPE II REFLECTIVE F SF	REMOVING SIGNS TYPE II EACH	REMOVING SMALL SIGN SUPPORTS EACH
10+45	LT	1	R1-1	STOP	30x30	1	7.46	--	1	1
14+54	LT	2	J13-2	CTH D	48x45	1	15.00	--	1	1
14+54	LT	---	---	CTH XX	-	--	--	--	1	--
14+54	LT	---	---	ARROW LEFT	-	---	---	---	1	--
14+54	LT	---	---	ARROW RIGHT	-	--	---	---	1	--
17+13	RT	3	W14-3	NO PASS ZONE	48x36	1	--	10.70	1	1
20+32	LT	4	J1-1	JCT	24x39	1	6.50	--	1	1
20+32	LT	---	---	CTH XX	-	--	--	--	1	--
80+60	RT	5	W1-1L	LEFT TURN	36x36	1	--	9.00	1	1
80+60	---	---	W13-1	30 MPH	18x18	--	--	4.00	1	--
88+12	RT	6	W1-6	CURVE LEFT	48x24	1	--	8.00	1	1
89+67	RT	7	W1-6	CURVE RIGHT	48x24	1	--	8.00	1	1
95+20	LT	8	W1-1L	LEFT TURN	36x36	1	--	9.00	2	1
95+20	---	---	W13-1	30 MPH	18x18	1	--	2.25	--	--
95+66	RT	9	W14-3	NO PASS ZONE	48x36	1	--	10.70	1	1
107+05	LT	10	W14-3	NO PASS ZONE	48x36	1	--	10.70	1	1
108+62	RT	11	W1-10R	RT CURVE / INTERSECTION	30x30	1	--	6.25	1	1
108+62	---	---	W13-1	30 MPH	18x18	1	--	2.25	1	---
114+68	LT	12	---	CTH D	-	--	--	--	1	1
114+68	---	---	---	RT TURN	-	--	--	--	1	---
114+57	LT	13	W1-6	RT TURN	48x24	1	--	8.00	--	---
114+90	LT	14	R1-1	STOP	30x30	1	7.46	--	1	1
114+90	LT	40	W1-6	RT TURN	48x24	1	--	8.00	--	--
115+14	LT	15	---	LT / RT ARROW	-	--	--	--	1	1
115+86	LT	16	W1-6	RT TURN	48x24	1	--	8.00	--	---
116+56	LT	17	---	CTH D & RT TURN ARROW	-	---	---	---	1	1
121+76	LT	18	W1-10L	LT CURVE / INTERSECTION	30x30	1	--	9.00	1	1
121+76	LT	---	W13-1	30 MPH	18x18	--	--	4.00	1	---
121+88	RT	19	W14-3	NO PASS ZONE	48x36	1	--	10.70	1	1
126+27	LT	20	W14-3	NO PASS ZONE	48x36	1	--	10.70	1	1
135+56	RT	21	W2-1	CROSS ROAD AHD	30x30	1	--	6.25	1	1
140+97	LT	22	R1-1	STOP	30x30	1	7.46	--	1	1
147+22	LT	23	W2-1	CROSS ROAD AHD	30x30	1	--	6.25	1	1
149+39	RT	24	W14-3	NO PASS ZONE	48x36	1	--	10.70	1	1
161+73	LT	25	W14-3	NO PASS ZONE	48x36	1	--	10.70	1	1
167+65	LT	26	W1-7	LT / RT ARROW	48x24	1	--	8.00	1	1
167+85	RT	27	R1-1	STOP	30x30	1	7.46	--	1	1
173+74	LT	28	W2-2	SIDE RD	30x30	1	--	6.25	1	1
178+42	LT	29	W14-3	NO PASS ZONE	48x36	1	--	10.70	1	1
187+23	LT	30	W11-4	CATTLE CROSSING	30x30	1	--	6.25	1	1
187+80	RT	31	W2-2	SIDE RD	30x30	1	--	6.25	1	1
192+34	RT	32	J1-1	JCT	24x39	1	6.50	--	1	1
192+34	---	---	---	STH 27	-	---	---	---	1	---
193+80	LT	33	R1-1	STOP	30x30	1	7.46	--	1	1
196+76	RT	34	W3-1	STOP AHEAD	36x36	1	--	9.00	1	1
204+75	RT	35	R1-1	STOP	30x30	1	7.46	--	1	1
204+72	RT	36	J13-2	STH 27	48x45	1	15.00	--	1	2
204+72	---	---	---	LT & RT ARROW	-	---	---	---	1	---
204+72	---	---	---	CTH D	-	---	---	---	1	---
204+72	-	---	---	RT TURN	-	---	---	---	1	---
204+72	RT	37	---	NO PASS ZONE	-	---	---	---	1	1
204+89	LT	38	M1-5A	CTH D	24x24	1	9.00	--	1	1
204+89	---	---	M6-6R	STRAIGHT AHD & RT	21x21	1	6.00	--	1	---
205+00	---	39	W1-7	LT / RT ARROW	48x24	1	--	8.00	--	--
TOTAL 0010						39	102.76	227.60	50	37

PAVEMENT MARKING

STATION	TO	STATION	LOCATION	646.1020	646.6120	REMARKS
				MARKING LINE EPOXY 4-INCH LF	MARKING STOP LINE EPOXY 18-INCH LF	
9+73	-	204+80	EDGE LINES	38538	-	WHITE EDGE LINE
9+73	-	10+00	CTH XX CL	502	-	DOUBLE YELLOW
10+00	-	17+10	CL	888	11	SOLID W/ SKIPS
17+10	-	30+40	CL	333	-	SKIPS
30+40	-	44+30	CL	1738	-	SOLID W/ SKIPS
44+30	-	51+80	CL	1500	-	DOUBLE YELLOW
51+80	-	58+30	CL	813	-	SOLID W/ SKIPS
58+30	-	79+95	CL	541	-	SKIPS
79+95	-	87+12	CL	896	-	SOLID W/ SKIPS
87+12	-	91+00	CL	776	-	DOUBLE YELLOW
91+00	-	95+75	CL	594	-	SOLID W/ SKIPS
95+75	-	107+10	CL	284	-	SKIPS
107+10	-	113+33	CL	779	-	SOLID W/ SKIPS
113+33	-	117+07	CL	748	-	DOUBLE YELLOW
117+07	-	121+85	CL	598	-	SOLID W/ SKIPS
121+85	-	126+23	CL	109	-	SKIPS
126+23	-	135+88	CL	1207	-	SOLID W/ SKIPS
135+88	-	142+07	CL	1238	-	DOUBLE YELLOW
142+07	-	149+40	CL	917	-	SOLID W/ SKIPS
149+40	-	161+71	CL	308	-	SKIPS
161+71	-	168+40	CL	836	-	SOLID W/ SKIPS
168+40	-	178+38	CL	250	-	SKIPS
178+38	-	190+51	CL	1516	-	SOLID W/ SKIPS
190+51	-	204+80	CL	2857	32	DOUBLE YELLOW
TOTAL 0010				58,766	43	

PROJECT NO: 7823-07-73 HWY: CTH D COUNTY: EAU CLAIRE MISCELLANEOUS QUANTITIES SHEET E

FILE NAME : C:\OD\CORRE, INC\PROJECTS - DOCUMENTS\WI - NW REGION\7823-07-03_EAU CLAIRE CO_CTH D\500_CADD\501_C3D_2018\78230703\SHEETS\PLAN\030201-MQ.DWG PLOT DATE : 2/18/2022 11:30 AM PLOT BY : BOBBY JONES PLOT NAME : PLOT SCALE : 1" = 1' LAYOUT NAME - 03 WISDOT/CADD SHEET 42

TRANSPORTATION PROJECT PLAT NO: 7823-07-03 - 4.02

THAT PART OF THE NW 1/4 OF THE NE 1/4, SECTION 13, TOWNSHIP 27 NORTH, RANGE 7 WEST, TOWN OF LUDINGTON, EAU CLAIRE COUNTY, WISCONSIN.

RELOCATION ORDER: FALL CREEK - NORTH COUNTY LINE, CTH XX TO STH 27, CTH D, EAU CLAIRE COUNTY

TO PROPERLY ESTABLISH, LAY OUT, WIDEN, ENLARGE, EXTEND, CONSTRUCT, RECONSTRUCT, IMPROVE, OR MAINTAIN A PORTION OF THE HIGHWAY DESIGNATED ABOVE, THE COUNTY OF EAU CLAIRE DEEMS IT NECESSARY TO RELOCATE OR CHANGE SAID HIGHWAY AND ACQUIRE CERTAIN LANDS AND INTERESTS OR RIGHTS IN LANDS FOR THE ABOVE PROJECT.

TO EFFECT THIS CHANGE, PURSUANT TO AUTHORITY GRANTED UNDER SECTION 83.07 (3), 83.08 (1a) OR (1b) WISCONSIN STATUTES, THE COUNTY OF EAU CLAIRE HEREBY ORDERS THAT:

1. THAT PORTION OF SAID HIGHWAY AS SHOWN ON THIS PLAT IS LAID OUT AND ESTABLISHED TO THE LINES AND WIDTHS AS SO SHOWN FOR THE ABOVE PROJECT.
2. THE LANDS OR INTERESTS OR RIGHTS IN LANDS AS SHOWN ON THIS PLAT ARE REQUIRED BY THE COUNTY FOR THE ABOVE PROJECT AND SHALL BE ACQUIRED IN THE NAME OF THE COUNTY OF EAU CLAIRE, PURSUANT TO THE PROVISIONS OF SECTION 83.08 (1a) OR (1b), WISCONSIN STATUTES.

1215495
TINA K. POMMIER
EAU CLAIRE COUNTY WI
REGISTER OF DEEDS
RECORDED ON
07/09/2021 08:13 AM
REC FEE: 25.00
TRANS FEE:
EJECT #:
PAGES: 1

RESERVED FOR REGISTER OF DEEDS
PROJECT NUMBER: 7823-07-03-4.02
AMENDMENT NO. _____

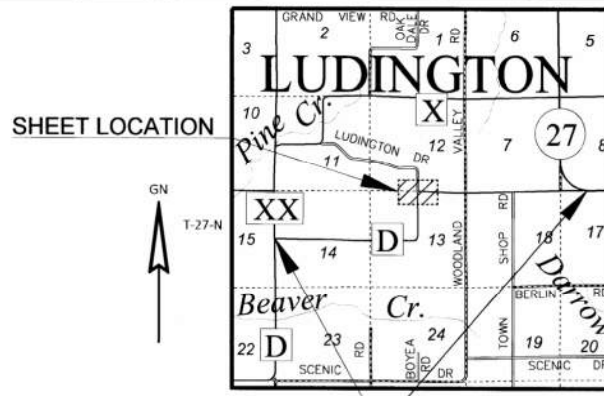

TOWN
SE-SW
PRW 204
2-1/4"
IRON PIPE
Y = 285093.53
X = 423301.20
PI: 115+75.17

PI STA = 115+75.17
Y = 285094.61
X = 423300.06
DELTA = 92°44'07", RT
D = 24°48'12"
T = 242.30'
L = 373.88'
R = 231.00'
PC STA = 113+32.87
Y = 284852.32
X = 423302.11
PT STA = 117+06.75
Y = 285085.09
X = 423542.17

UNPLATTED
LANDS

PROJECT LOCATION
(LOCATION SKETCH NOT TO SCALE)

SW-SE

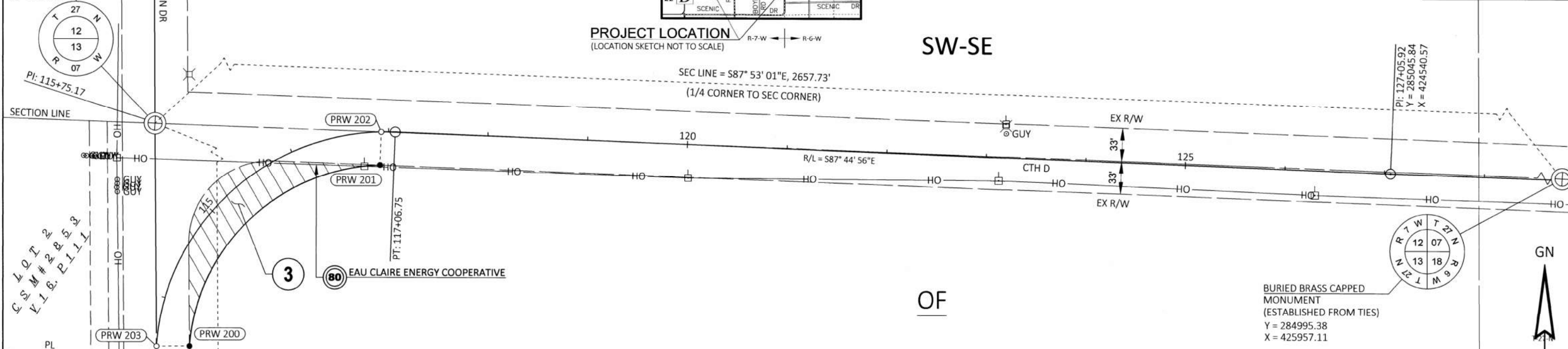

BURIED BRASS CAPPED
MONUMENT
(ESTABLISHED FROM TIES)
Y = 284995.38
X = 425957.11

OF

NE-NW

UNPLATTED
LANDS

PRW 200 - PRW 201

L = 289.26'
LCH = 264.21'
CB = N46° 19' 52"E
R = 198.00'
Δ = 83° 42' 14"

COURSE TABLE

POINT	POINT	BEARING	DISTANCE
PRW 200	PRW 201	CURVE DATA	
PRW 201	PRW 202	N02° 06' 59"E	33.00'
PRW 202	PRW 204	N87° 53' 01"W	226.99'
PRW 204	PRW 203	S00° 23' 05"E	224.02'
PRW 203	PRW 200	N89° 36' 55"E	33.00'

POINT TABLE

POINT	STATION	OFFSET	Y	X
PRW 200	116+90.35	33.00', RT	284,869.73	423,335.70
PRW 201	113+52.88	33.00', RT	285,052.17	423,526.82
PRW 202	113+50.08	0.10', RT	285,085.15	423,528.04
PRW 203	116+92.62	0.07', RT	284,869.51	423,302.70
PRW 204	115+19.86	102.20', LT	285,093.53	423,301.20

EXISTING UTILITY EASEMENTS

EAU CLAIRE ENERGY COOPERATIVE
PARCEL 3 - DOC. # 940487

SCHEDULE OF LANDS & INTERESTS REQUIRED

OWNERS NAMES ARE SHOWN FOR REFERENCE ONLY AND ARE SUBJECT TO CHANGE PRIOR TO THE TRANSFER OF LAND INTERESTS TO THE COUNTY.

PARCEL NUMBER	OWNER	INTEREST REQUIRED	RIGHT OF WAY REQUIRED		
			NEW (AC)	EXISTING (AC)	TOTAL (AC)
3	RUSSEL VOLBRECHT	FEE	0.17	0.35	0.52

UTILITY INTERESTS REQUIRED

UTILITY NUMBER	OWNER	INTEREST REQUIRED
80	EAU CLAIRE ENERGY COOPERATIVE	RELEASE OF RIGHTS

LUDINGTON

NOTES:
POSITIONS SHOWN ON THIS PLAT ARE WISCONSIN COORDINATE REFERENCE SYSTEM COORDINATES (WISCRS), EAU CLAIRE COUNTY, NAD83 (2011) IN US SURVEY FEET. VALUES SHOWN ARE GRID COORDINATES, GRID BEARINGS, AND GRID DISTANCES. GRID DISTANCES MAY BE USED AS GROUND DISTANCES.
ALL NEW RIGHT-OF-WAY MONUMENTS WILL BE TYPE 2 (TYPICALLY 3/4"x24" IRON REBARS) UNLESS OTHERWISE NOTED, AND WILL BE PLACED PRIOR TO THE COMPLETION OF THE PROJECT.
RIGHT-OF-WAY BOUNDARIES ARE DEFINED WITH COURSES OF THE PERIMETER OF THE HIGHWAY LANDS REFERENCED TO THE U.S. PUBLIC LAND SURVEY SYSTEM OR OTHER "SURVEYS" OF PUBLIC RECORD.
EXISTING HIGHWAY RIGHT-OF-WAY HEREIN IS BASED ON THE FOLLOWING: EXISTING HIGHWAY RIGHT-OF-WAY OF CTH D AND LUDINGTON DRIVE IS BASED ON EXISTING CENTERLINE AND WISCONSIN STATUTE 87.31 COMPLEMENTED BY CSM NO. 2853.
PROPERTY LINES SHOWN ON THIS PLAT ARE DRAWN FROM DATA DERIVED FROM MAPS AND DOCUMENTS OF PUBLIC RECORD AND/OR EXISTING OCCUPATIONAL LINES. THIS PLAT MAY NOT BE A TRUE REPRESENTATION OF EXISTING PROPERTY LINES, EXCLUDING RIGHT-OF-WAY, AND SHOULD NOT BE USED AS A SUBSTITUTE FOR AN ACCURATE FIELD SURVEY.
ALL RIGHT-OF-WAY LINES DEPICTED IN THE NON-ACQUISITION AREAS ARE INTENDED TO RE-ESTABLISH EXISTING RIGHT-OF-WAY LINES AS DETERMINED FROM PREVIOUS PROJECTS, OTHER RECORDED DOCUMENTS, OR FROM CENTERLINE OF EXISTING PAVEMENTS.
PARCEL AND UTILITY IDENTIFICATION NUMBERS MAY NOT POINT TO ALL AREAS OF ACQUISITION AS NOTED ON TYP PLAN DETAIL PAGES.
FOR LATEST ACCESS / DRIVEWAY INFORMATION, CONTACT THE EAU CLAIRE COUNTY HIGHWAY DEPARTMENT.
DIMENSIONING FOR THE NEW RIGHT-OF-WAY IS MEASURED ALONG AND PERPENDICULAR TO THE NEW REFERENCE LINES.

CONVENTIONAL SYMBOLS

CONVENTIONAL ABBREVIATIONS

CONVENTIONAL UTILITY SYMBOLS

CURVE DATA ABBREVIATIONS

CORRE ENGINEERING
1802 WARDEN STREET
EAU CLAIRE, WI 54703
(608)828-1011
www.correinc.com

I, BRYON J. MOTSZKO PROFESSIONAL LAND SURVEYOR, HEREBY CERTIFY THAT IN FULL COMPLIANCE WITH THE PROVISIONS OF SECTION 84.095 OF THE WISCONSIN STATUTES AND UNDER THE DIRECTION OF EAU CLAIRE COUNTY, I HAVE SURVEYED AND MAPPED THIS TRANSPORTATION PROJECT PLAT AND SUCH PLAT CORRECTLY REPRESENTS ALL EXTERIOR BOUNDARIES OF THE SURVEYED LAND.

SIGNATURE: *Bryon J. Motzsko* DATE: 7/6/21
PRINT NAME: BRYON J. MOTSZKO
REGISTRATION NUMBER: 5-2846
THIS PLAT AND RELOCATION ORDER ARE APPROVED FOR EAU CLAIRE COUNTY REGION OFFICE
SIGNATURE: *Jon Johnson* DATE: 7/5/21
PRINT NAME: JON JOHNSON
EAU CLAIRE COUNTY HIGHWAY COMMISSIONER

TOWN

SCHEDULE OF LANDS & INTERESTS REQUIRED

OWNERS NAMES ARE SHOWN FOR REFERENCE ONLY AND ARE SUBJECT TO CHANGE PRIOR TO THE TRANSFER OF LAND INTERESTS TO THE COUNTY.

Table with columns: PARCEL NUMBER, OWNER, INTEREST REQUIRED, RIGHT OF WAY REQUIRED (NEW, EXISTING, TOTAL), TLE REQUIRED (TOTAL).

UTILITY INTERESTS REQUIRED

Table with columns: UTILITY NUMBER, OWNER, INTEREST REQUIRED.

COURSE TABLE

Table with columns: POINT - POINT, BEARING, DISTANCE.

PRW 310 BURIED ALUMINUM MONUMENT (ESTABLISHED FROM TIES) Y = 285146.44 X = 431237.49

POINT TABLE with columns: POINT, STATION, OFFSET, Y, X.

TRANSPORTATION PROJECT PLAT NO: 7823-07-03 - 4.03

THAT PART OF THE SW 1/4 OF THE SW 1/4, SECTION 8, AND THE NW 1/4 OF THE NW 1/4, SECTION 17, ALL IN TOWNSHIP 27 NORTH, RANGE 6 WEST, TOWN OF LUDINGTON, EAU CLAIRE COUNTY, WISCONSIN.

RELOCATION ORDER: FALL CREEK - NORTH COUNTY LINE, CTH XX TO STH 27, CTH D, EAU CLAIRE COUNTY

TO PROPERLY ESTABLISH, LAY OUT, WIDEN, ENLARGE, EXTEND, CONSTRUCT, RECONSTRUCT, IMPROVE, OR MAINTAIN A PORTION OF THE HIGHWAY DESIGNATED ABOVE, THE COUNTY OF EAU CLAIRE DEEMS IT NECESSARY TO RELOCATE OR CHANGE SAID HIGHWAY AND ACQUIRE CERTAIN LANDS AND INTERESTS OR RIGHTS IN LANDS FOR THE ABOVE PROJECT.

TO EFFECT THIS CHANGE, PURSUANT TO AUTHORITY GRANTED UNDER SECTION 83.07 (3), 83.08 (1a) OR (1b) WISCONSIN STATUTES, THE COUNTY OF EAU CLAIRE HEREBY ORDERS THAT:

- 1. THAT PORTION OF SAID HIGHWAY AS SHOWN ON THIS PLAT IS LAID OUT AND ESTABLISHED TO THE LINES AND WIDTHS AS SO SHOWN FOR THE ABOVE PROJECT.
2. THE LANDS OR INTERESTS OR RIGHTS IN LANDS AS SHOWN ON THIS PLAT ARE REQUIRED BY THE COUNTY FOR THE ABOVE PROJECT AND SHALL BE ACQUIRED IN THE NAME OF THE COUNTY OF EAU CLAIRE, PURSUANT TO THE PROVISIONS OF SECTION 83.08 (1a) OR (1b), WISCONSIN STATUTES.

EXISTING UTILITY EASEMENTS

- (80) EAU CLAIRE ENERGY COOPERATIVE PARCEL 4 - DOC. # 1121549 PARCEL 5 - DOC. # 418317, 493593
(81) CENTURYTEL, INC. PARCEL 4 - DOC. # 454385, 795652
(82) VIKING GAS TRANSMISSION COMPANY PARCEL 5 - DOC. # 312541, 635447

SCALE, FEET

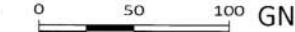

PI STA = 204+10.49
Y = 285141.66
X = 432242.33
DELTA = 69°16'53", LT
D = 57°17'45"
T = 69.09'
L = 120.92'
R = 100.00'
PC STA = 203+41.40
Y = 285142.29
X = 432173.24
PT STA = 204+62.32
Y = 285206.05
X = 432267.36

BURIED ALUMINUM MONUMENT (ESTABLISHED FROM TIES) Y = 285160.52 X = 433891.57

1215496

TINA K. POMMIER
EAU CLAIRE COUNTY WI
REGISTER OF DEEDS
RECORDED ON
07/09/2021 08:13 AM
REC FEE: 25.00
TRANS FEE:
EXEMPT #:
PAGES: 1

RESERVED FOR REGISTER OF DEEDS
PROJECT NUMBER: 7823-07-03-4.03
AMENDMENT NO.:

SE-SE

SE-SW

NE-NE

NE-NW

UNPLATTED LANDS OF SW-SW

PARCEL 1 PLAT OF SURVEY T-1134

PARCEL 2 PLAT OF SURVEY T-1134

LUDINGTON

SHEET LOCATION

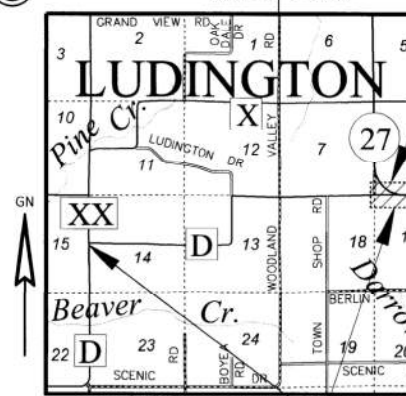

PROJECT LOCATION (LOCATION SKETCH NOT TO SCALE)

NOTES:

POSITIONS SHOWN ON THIS PLAT ARE WISCONSIN COORDINATE REFERENCE SYSTEM COORDINATES (WISCRS), EAU CLAIRE COUNTY, NAD83 (2011) IN US SURVEY FEET. VALUES SHOWN ARE GRID COORDINATES, GRID BEARINGS, AND GRID DISTANCES. GRID DISTANCES MAY BE USED AS GROUND DISTANCES.

ALL NEW RIGHT-OF-WAY MONUMENTS WILL BE TYPE 2 (TYPICALLY 3/4"x24" IRON REBARS) UNLESS OTHERWISE NOTED, AND WILL BE PLACED PRIOR TO THE COMPLETION OF THE PROJECT.

RIGHT-OF-WAY BOUNDARIES ARE DEFINED WITH COURSES OF THE PERIMETER OF THE HIGHWAY LANDS REFERENCED TO THE U.S. PUBLIC LAND SURVEY SYSTEM OR OTHER "SURVEYS" OF PUBLIC RECORD.

EXISTING HIGHWAY RIGHT-OF-WAY HEREIN IS BASED ON THE FOLLOWING: EXISTING HIGHWAY RIGHT-OF-WAY OF CTH D IS BASED ON EXISTING CENTERLINE AND WISCONSIN STATUTE 82.31 COMPLEMENTED BY MAP OF SURVEY FILED AS T-1134 WITH THE COUNTY SURVEYOR'S OFFICE. STH 27 RIGHT-OF-WAY IS BASED ON WISDOT PLAT 6437B, DATED NOVEMBER 1943.

A TEMPORARY LIMITED EASEMENT (TLE) IS A RIGHT FOR CONSTRUCTION PURPOSES, AS DEFINED HEREIN, INCLUDING THE RIGHT TO OPERATE NECESSARY EQUIPMENT THEREON; THE RIGHT OF INGRESS AND EGRESS, AS LONG AS REQUIRED FOR SUCH PUBLIC PURPOSE, INCLUDING THE RIGHT TO PRESERVE, PROTECT, REMOVE, OR PLANT THEREON ANY VEGETATION THAT THE HIGHWAY AUTHORITIES MAY DEEM DESIRABLE. ALL (TLE)'S ON THIS PLAT EXPIRE AT THE COMPLETION OF THE CONSTRUCTION PROJECT FOR WHICH THIS INSTRUMENT IS GIVEN.

PROPERTY LINES SHOWN ON THIS PLAT ARE DRAWN FROM DATA DERIVED FROM MAPS AND DOCUMENTS OF PUBLIC RECORD AND/OR EXISTING OCCUPATIONAL LINES. THIS PLAT MAY NOT BE A TRUE REPRESENTATION OF EXISTING PROPERTY LINES, EXCLUDING RIGHT-OF-WAY, AND SHOULD NOT BE USED AS A SUBSTITUTE FOR AN ACCURATE FIELD SURVEY.

ALL RIGHT-OF-WAY LINES DEPICTED IN THE NON-ACQUISITION AREAS ARE INTENDED TO RE-ESTABLISH EXISTING RIGHT-OF-WAY LINES AS DETERMINED FROM PREVIOUS PROJECTS, OTHER RECORDED DOCUMENTS, OR FROM CENTERLINE OF EXISTING PAVEMENTS.

PARCEL AND UTILITY IDENTIFICATION NUMBERS MAY NOT POINT TO ALL AREAS OF ACQUISITION AS NOTED ON TYP PLAN DETAIL PAGES. FOR LATEST ACCESS / DRIVEWAY INFORMATION, CONTACT THE EAU CLAIRE COUNTY HIGHWAY DEPARTMENT.

DIMENSIONING FOR THE NEW RIGHT-OF-WAY IS MEASURED ALONG AND PERPENDICULAR TO THE NEW REFERENCE LINES.

Legend area containing CONVENTIONAL SYMBOLS, CONVENTIONAL ABBREVIATIONS, and CONVENTIONAL UTILITY SYMBOLS with various symbols and their corresponding meanings.

BENCH MARKS				
NO.	STATION	DESCRIPTION	ELEV.	
5	141+22.27	147.80', LT	MAG NAIL	1068.992'



TOWN
SE-SE

SW-SW

OF

NE-NE

NW-NW

LUDINGTON

STA 138+00

STA 151+50

MATCH LINE

MATCH LINE

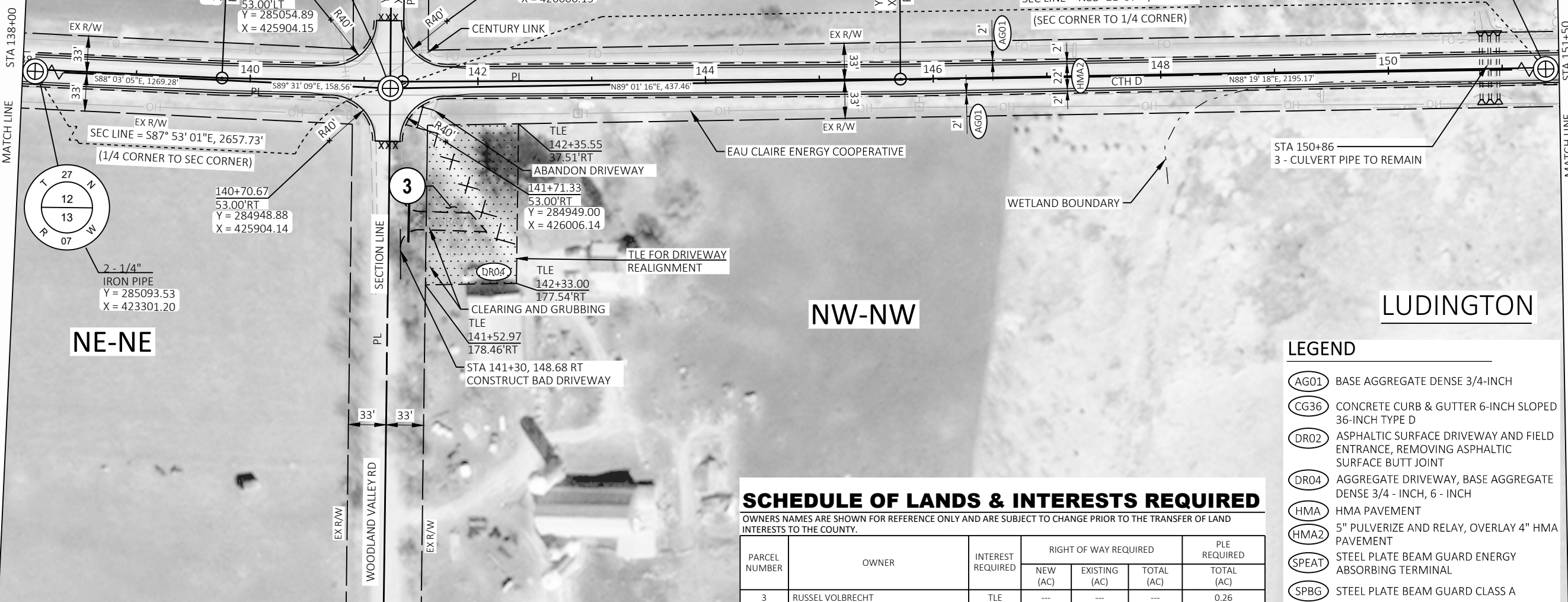

LEGEND

- (AG01) BASE AGGREGATE DENSE 3/4-INCH
- (CG36) CONCRETE CURB & GUTTER 6-INCH SLOPED 36-INCH TYPE D
- (DR02) ASPHALTIC SURFACE DRIVEWAY AND FIELD ENTRANCE, REMOVING ASPHALTIC SURFACE BUTT JOINT
- (DR04) AGGREGATE DRIVEWAY, BASE AGGREGATE DENSE 3/4 - INCH, 6 - INCH
- (HMA) HMA PAVEMENT
- (HMA2) 5" PULVERIZE AND RELAY, OVERLAY 4" HMA PAVEMENT
- (SPEAT) STEEL PLATE BEAM GUARD ENERGY ABSORBING TERMINAL
- (SPBG) STEEL PLATE BEAM GUARD CLASS A XXXXXX SAWING ASPHALT

SCHEDULE OF LANDS & INTERESTS REQUIRED

OWNERS NAMES ARE SHOWN FOR REFERENCE ONLY AND ARE SUBJECT TO CHANGE PRIOR TO THE TRANSFER OF LAND INTERESTS TO THE COUNTY.

PARCEL NUMBER	OWNER	INTEREST REQUIRED	RIGHT OF WAY REQUIRED			PLE REQUIRED
			NEW (AC)	EXISTING (AC)	TOTAL (AC)	TOTAL (AC)
3	RUSSEL VOLBRECHT	TLE	---	---	---	0.26

4

4

REVISION DATE	DATE	SCALE, FEET 0 50 100	HWY: CTH D	STATE R/W PROJECT NUMBER	PLAT SHEET 4.
	GRID FACTOR		COUNTY: EAU CLAIRE	CONSTRUCTION PROJECT NUMBER 7823-07-73	PS&E SHEET

BENCH MARKS			
NO.	STATION	DESCRIPTION	ELEV.
1	15+82.48, 22.49' LT SET	MAG NAIL	1024.34



BEGIN PROJECT
STA 9+73.36
 Y = 282458.04
 X = 415339.85

END CONSTRUCTION
 STA 9+85, 102.0' LT
 MATCH EXISTING
 BUTT JOINT REQ'D
 SAW CUT REQ'D

SECTION CORNER
 E CORNER OF SECTION 14
 T-27-N, R-07-W

BEGIN CONSTRUCTION
 STA 9+88, 149.0' RT
 MATCH EXISTING
 BUTT JOINT REQ'D
 SAW CUT REQ'D

STA 19+85
 REMOVING SMALL CULVERT PIPE
 54 LF, 18-INCH CPCS
 1 - 24-INCH CPCPE 59 LF, REQ'D
 2 - 24 - INCH AEW, REQ'D
 INV. N - 1012.90
 INV. S - 1014.33
 SKEW - 0°

LEGEND

	BASE AGGREGATE DENSE 3/4-INCH
	CONCRETE CURB & GUTTER 6-INCH SLOPED 36-INCH TYPE D
	ASPHALTIC SURFACE DRIVEWAY AND FIELD ENTRANCE, REMOVING ASPHALTIC SURFACE BUTT JOINT
	AGGREGATE DRIVEWAY, BASE AGGREGATE DENSE 3/4 - INCH, 6 - INCH
	HMA PAVEMENT
	5" PULVERIZE AND RELAY, OVERLAY 4" HMA PAVEMENT
	STEEL PLATE BEAM GUARD ENERGY ABSORBING TERMINAL
	STEEL PLATE BEAM GUARD CLASS A
	SAWING ASPHALT



BENCH MARKS			
NO.	STATION	DESCRIPTION	ELEV.
2	35+58.54, 41.37' RT	NO. 6 REBAR W/ CAP	1037.04

5

5

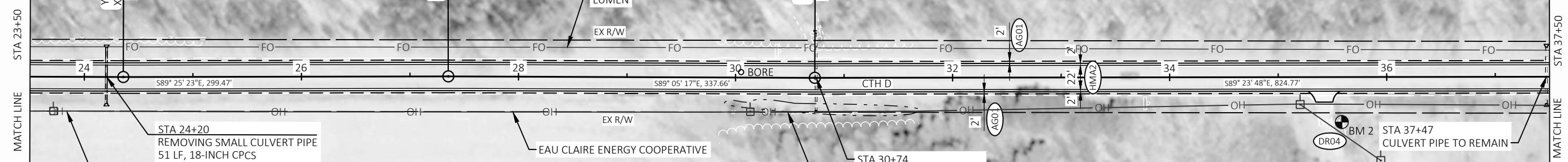

STA 24+20
 REMOVING SMALL CULVERT PIPE
 51 LF, 18-INCH CPCPE
 1 - 18-INCH CPCPE 51 LF, REQ'D
 2 - 18 - INCH AEW, REQ'D
 INV. N - 1014.30
 INV. S - 1015.27
 SKEW - 0°

EAU CLAIRE ENERGY COOPERATIVE

STA 30+74
 CULVERT PIPE TO REMAIN

STA 37+47
 CULVERT PIPE TO REMAIN

LEGEND

	BASE AGGREGATE DENSE 3/4-INCH
	CONCRETE CURB & GUTTER 6-INCH SLOPED 36-INCH TYPE D
	ASPHALTIC SURFACE DRIVEWAY AND FIELD ENTRANCE, REMOVING ASPHALTIC SURFACE BUTT JOINT
	AGGREGATE DRIVEWAY, BASE AGGREGATE DENSE 3/4 - INCH, 6 - INCH
	HMA PAVEMENT
	5" PULVERIZE AND RELAY, OVERLAY 4" HMA PAVEMENT
	STEEL PLATE BEAM GUARD ENERGY ABSORBING TERMINAL
	STEEL PLATE BEAM GUARD CLASS A
	SAWING ASPHALT

5



5

LEGEND

- (AG01) BASE AGGREGATE DENSE 3/4-INCH
- (CG36) CONCRETE CURB & GUTTER 6-INCH SLOPED 36-INCH TYPE D
- (DR02) ASPHALTIC SURFACE DRIVEWAY AND FIELD ENTRANCE, REMOVING ASPHALTIC SURFACE BUTT JOINT
- (DR04) AGGREGATE DRIVEWAY, BASE AGGREGATE DENSE 3/4 - INCH, 6 - INCH
- (HMA) HMA PAVEMENT
- (HMA2) 5" PULVERIZE AND RELAY, OVERLAY 4" HMA PAVEMENT
- (SPEAT) STEEL PLATE BEAM GUARD ENERGY ABSORBING TERMINAL
- (SPBG) STEEL PLATE BEAM GUARD CLASS A
- XXXXXX SAWING ASPHALT

5

5



STA 62+59
 REMOVING SMALL CULVERT PIPE
 49 LF 18-INCH CPCS
 1 - 18 - INCH, 46 LF CPCPE REQ'D
 2 - 18 - INCH AEW REQ'D
 INV. N 1005.30
 INV. S 1006.20

LEGEND

(AG01)	BASE AGGREGATE DENSE 3/4-INCH
(CG36)	CONCRETE CURB & GUTTER 6-INCH SLOPED 36-INCH TYPE D
(DR02)	ASPHALTIC SURFACE DRIVEWAY AND FIELD ENTRANCE, REMOVING ASPHALTIC SURFACE BUTT JOINT
(DR04)	AGGREGATE DRIVEWAY, BASE AGGREGATE DENSE 3/4 - INCH, 6 - INCH
(HMA)	HMA PAVEMENT
(HMA2)	5" PULVERIZE AND RELAY, OVERLAY 4" HMA PAVEMENT
(SPEAT)	STEEL PLATE BEAM GUARD ENERGY ABSORBING TERMINAL
(SPBG)	STEEL PLATE BEAM GUARD CLASS A
XXXXXX	SAWING ASPHALT

BENCH MARKS			
NO.	STATION	DESCRIPTION	ELEV.
3	74+10.52, 16.70', LT	NO. 6 REBAR W/ CAP	989.31



5

5

MATCH LINE STA 65+00

MATCH LINE STA 78+50



LEGEND

- (AG01) BASE AGGREGATE DENSE 3/4-INCH
- (CG36) CONCRETE CURB & GUTTER 6-INCH SLOPED 36-INCH TYPE D
- (DR02) ASPHALTIC SURFACE DRIVEWAY AND FIELD ENTRANCE, REMOVING ASPHALTIC SURFACE BUTT JOINT
- (DR04) AGGREGATE DRIVEWAY, BASE AGGREGATE DENSE 3/4 - INCH, 6 - INCH
- (HMA) HMA PAVEMENT
- (HMA2) 5" PULVERIZE AND RELAY, OVERLAY 4" HMA PAVEMENT
- (SPEAT) STEEL PLATE BEAM GUARD ENERGY ABSORBING TERMINAL
- (SPBG) STEEL PLATE BEAM GUARD CLASS A
- XXXXXX SAWING ASPHALT

PROJECT NO: 7823-07-73	HWY: CTH D	COUNTY: EAU CLAIRE	PLAN DETAILS	SHEET	E
------------------------	------------	--------------------	--------------	-------	---

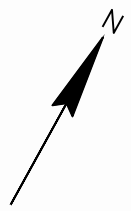

Y = 282366.42
 X = 422500.57
 PI: 81+33.40

PI STA = 89+56.13
 Y = 282368.936
 X = 423321.296
 DELTA = 90°15'42"
 D = 23°17'27"
 T = 247.13'
 L = 387.54'
 R = 246.00'
 PC STA = 87+09.00
 PT STA = 90+96.54
 SE = 6.0%

LEGEND	
AG01	BASE AGGREGATE DENSE 3/4-INCH
CG36	CONCRETE CURB & GUTTER 6-INCH SLOPED 36-INCH TYPE D
DR02	ASPHALTIC SURFACE DRIVEWAY AND FIELD ENTRANCE, REMOVING ASPHALTIC SURFACE BUTT JOINT
DR04	AGGREGATE DRIVEWAY, BASE AGGREGATE DENSE 3/4 - INCH, 6 - INCH
HMA	HMA PAVEMENT
HMA2	5" PULVERIZE AND RELAY, OVERLAY 4" HMA PAVEMENT
SPEAT	STEEL PLATE BEAM GUARD ENERGY ABSORBING TERMINAL
SPBG	STEEL PLATE BEAM GUARD CLASS A
XXXXXX	SAWING ASPHALT

5

5

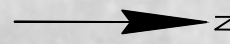

MATCH LINE
STA 94+50

MATCH LINE
STA 108+00



LEGEND

AG01	BASE AGGREGATE DENSE 3/4-INCH
CG36	CONCRETE CURB & GUTTER 6-INCH SLOPED 36-INCH TYPE D
DR02	ASPHALTIC SURFACE DRIVEWAY AND FIELD ENTRANCE, REMOVING ASPHALTIC SURFACE BUTT JOINT
DR04	AGGREGATE DRIVEWAY, BASE AGGREGATE DENSE 3/4 - INCH, 6 - INCH
HMA	HMA PAVEMENT
HMA2	5" PULVERIZE AND RELAY, OVERLAY 4" HMA PAVEMENT
SPEAT	STEEL PLATE BEAM GUARD ENERGY ABSORBING TERMINAL
SPBG	STEEL PLATE BEAM GUARD CLASS A
XXXXXX	SAWING ASPHALT

PROJECT NO: 7823-07-73	HWY: CTH D	COUNTY: EAU CLAIRE	PLAN DETAILS	SHEET	E
------------------------	------------	--------------------	--------------	-------	----------



PI STA = 115+75.17
 Y = 285094.610
 X = 423300.059
 DELTA = 92°44'07"
 D = 24°48'12"
 T = 242.30'
 L = 373.88'
 R = 231.00'
 PC STA = 113+32.87
 PT STA = 117+06.75
 SE = 6.0%

LEGEND

- AG01 BASE AGGREGATE DENSE 3/4-INCH
- CG36 CONCRETE CURB & GUTTER 6-INCH SLOPED 36-INCH TYPE D
- DR02 ASPHALTIC SURFACE DRIVEWAY AND FIELD ENTRANCE, REMOVING ASPHALTIC SURFACE BUTT JOINT
- DR04 AGGREGATE DRIVEWAY, BASE AGGREGATE DENSE 3/4 - INCH, 6 - INCH
- HMA HMA PAVEMENT
- HMA2 5" PULVERIZE AND RELAY, OVERLAY 4" HMA PAVEMENT
- SPEAT STEEL PLATE BEAM GUARD ENERGY ABSORBING TERMINAL
- SPBG STEEL PLATE BEAM GUARD CLASS A
- XXXXXX SAWING ASPHALT

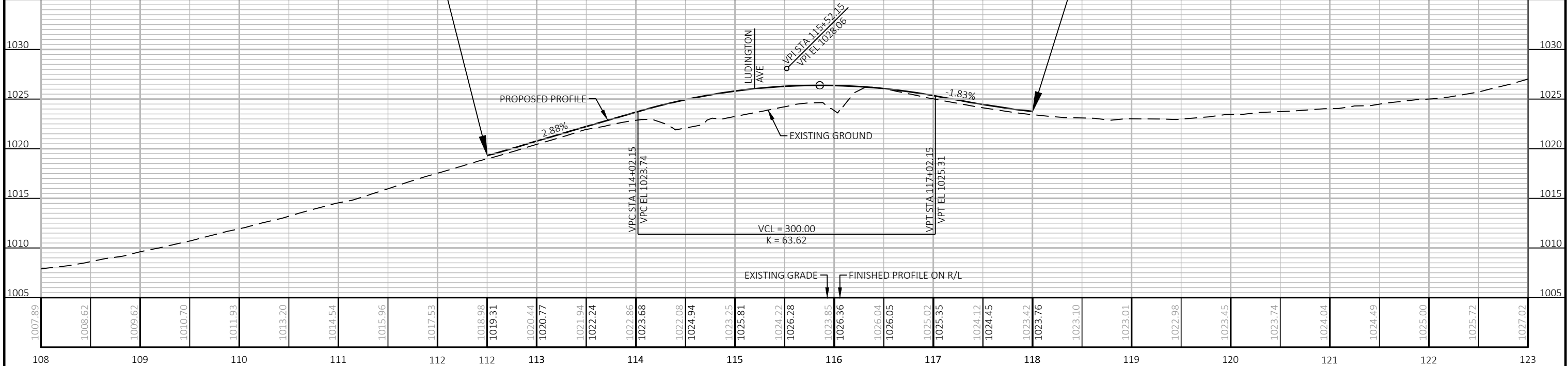

PROJECT NO: 7823-07-73	HWY: CTH D	COUNTY: EAU CLAIRE	PLAN AND PROFILE: CTH D	SHEET	E
------------------------	------------	--------------------	-------------------------	-------	----------

5

5



LEGEND

(AG01)	BASE AGGREGATE DENSE 3/4-INCH
(CG36)	CONCRETE CURB & GUTTER 6-INCH SLOPED 36-INCH TYPE D
(DR02)	ASPHALTIC SURFACE DRIVEWAY AND FIELD ENTRANCE, REMOVING ASPHALTIC SURFACE BUTT JOINT
(DR04)	AGGREGATE DRIVEWAY, BASE AGGREGATE DENSE 3/4 - INCH, 6 - INCH
(HMA)	HMA PAVEMENT
(HMA2)	5" PULVERIZE AND RELAY, OVERLAY 4" HMA PAVEMENT
(SPEAT)	STEEL PLATE BEAM GUARD ENERGY ABSORBING TERMINAL
(SPBG)	STEEL PLATE BEAM GUARD CLASS A
(XXXXX)	SAWING ASPHALT

BENCH MARKS			
NO.	STATION	DESCRIPTION	ELEV.
5	141+22.27, 147.80', LT	MAG NAIL	1068.992'



5

5



STA 141+34, 122.0 RT
 CONSTRUCT 16' BAD DRIVEWAY
 1 - 12-INCH CPCPE 36 LF, REQ'D
 2 - 12 - INCH AEW, REQ'D

SECTION CORNER
 SEC CORNER OF
 SECTION 12&13 T-27-N, R-07-W
 SECTION 7&18 T-27-N, R-06-W

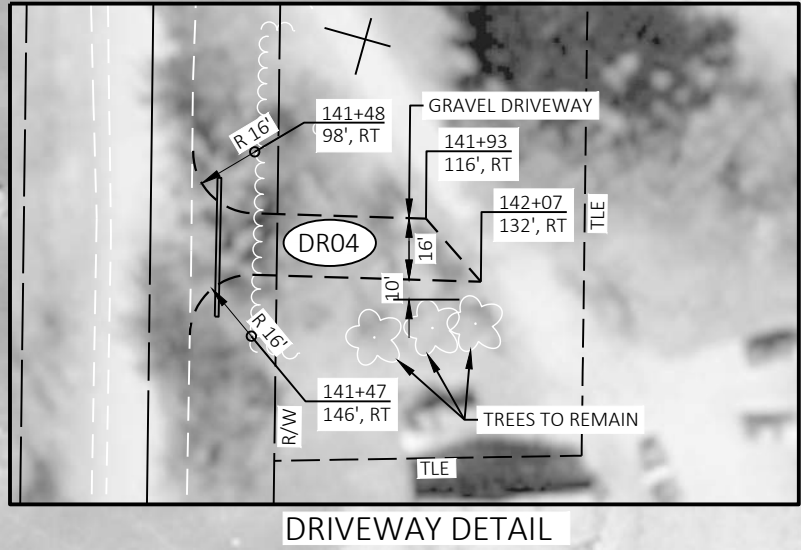

LEGEND	
(AGO1)	BASE AGGREGATE DENSE 3/4-INCH
(CG36)	CONCRETE CURB & GUTTER 6-INCH SLOPED 36-INCH TYPE D
(DR02)	ASPHALTIC SURFACE DRIVEWAY AND FIELD ENTRANCE, REMOVING ASPHALTIC SURFACE BUTT JOINT
(DR04)	AGGREGATE DRIVEWAY, BASE AGGREGATE DENSE 3/4 - INCH, 6 - INCH
(HMA)	HMA PAVEMENT
(HMA2)	5" PULVERIZE AND RELAY, OVERLAY 4" HMA PAVEMENT
(SPEAT)	STEEL PLATE BEAM GUARD ENERGY ABSORBING TERMINAL
(SPBG)	STEEL PLATE BEAM GUARD CLASS A
XXXXXX	SAWING ASPHALT

5

5



LEGEND

	BASE AGGREGATE DENSE 3/4-INCH
	CONCRETE CURB & GUTTER 6-INCH SLOPED 36-INCH TYPE D
	ASPHALTIC SURFACE DRIVEWAY AND FIELD ENTRANCE, REMOVING ASPHALTIC SURFACE BUTT JOINT
	AGGREGATE DRIVEWAY, BASE AGGREGATE DENSE 3/4 - INCH, 6 - INCH
	HMA PAVEMENT
	5" PULVERIZE AND RELAY, OVERLAY 4" HMA PAVEMENT
	STEEL PLATE BEAM GUARD ENERGY ABSORBING TERMINAL
	STEEL PLATE BEAM GUARD CLASS A
	SAWING ASPHALT

5

5



BENCH MARKS			
NO.	STATION	DESCRIPTION	ELEV.
6	167+56.14, 148.63', RT	MAG NAIL	1061.51

LEGEND	
(AG01)	BASE AGGREGATE DENSE 3/4-INCH
(CG36)	CONCRETE CURB & GUTTER 6-INCH SLOPED 36-INCH TYPE D
(DR02)	ASPHALTIC SURFACE DRIVEWAY AND FIELD ENTRANCE, REMOVING ASPHALTIC SURFACE BUTT JOINT
(DR04)	AGGREGATE DRIVEWAY, BASE AGGREGATE DENSE 3/4 - INCH, 6 - INCH
(HMA)	HMA PAVEMENT
(HMA2)	5" PULVERIZE AND RELAY, OVERLAY 4" HMA PAVEMENT
(SPEAT)	STEEL PLATE BEAM GUARD ENERGY ABSORBING TERMINAL
(SPBG)	STEEL PLATE BEAM GUARD CLASS A
XXXXXX	SAWING ASPHALT



5

5



STA 179+27
 REMOVING SMALL CULVERT PIPE
 51 LF 18-INCH CPCPE
 1 - 54 LF, 18 - INCH CPCPE, REQ'D
 2 - 18-INCH AEW, REQ'D
 INV. N - 1076.89
 INV. S - 1074.50
 SKEW 0°

Y = 285136.48
 X = 430767.90
 PI: 189+35.93

LEGEND

(AG01)	BASE AGGREGATE DENSE 3/4-INCH
(CG36)	CONCRETE CURB & GUTTER 6-INCH SLOPED 36-INCH TYPE D
(DR02)	ASPHALTIC SURFACE DRIVEWAY AND FIELD ENTRANCE, REMOVING ASPHALTIC SURFACE BUTT JOINT
(DR04)	AGGREGATE DRIVEWAY, BASE AGGREGATE DENSE 3/4 - INCH, 6 - INCH
(HMA)	HMA PAVEMENT
(HMA2)	5" PULVERIZE AND RELAY, OVERLAY 4" HMA PAVEMENT
(SPEAT)	STEEL PLATE BEAM GUARD ENERGY ABSORBING TERMINAL
(SPBG)	STEEL PLATE BEAM GUARD CLASS A
XXXXXX	SAWING ASPHALT

LEGEND

- AG01 BASE AGGREGATE DENSE 3/4-INCH
- CG36 CONCRETE CURB & GUTTER 6-INCH SLOPED 36-INCH TYPE D
- DR02 ASPHALTIC SURFACE DRIVEWAY AND FIELD ENTRANCE, REMOVING ASPHALTIC SURFACE BUTT JOINT
- DR04 AGGREGATE DRIVEWAY, BASE AGGREGATE DENSE 3/4 - INCH, 6 - INCH
- HMA HMA PAVEMENT
- HMA2 5" PULVERIZE AND RELAY, OVERLAY 4" HMA PAVEMENT
- SPEAT STEEL PLATE BEAM GUARD ENERGY ABSORBING TERMINAL
- SPBG STEEL PLATE BEAM GUARD CLASS A
- XXXXXX SAWING ASPHALT

PI STA = 204+10.49
 Y = 285141.656
 X = 432242.328
 DELTA = 69°16'53"
 D = 57°17'45"
 T = 69.09'
 L = 120.92'
 R = 100.00'
 PC STA = 203+41.40
 PT STA = 204+62.32
 SE = 6.0%

PI STA = 565'B'+39.97
 Y = 285104.711
 X = 431258.634
 DELTA = 90°17'00"
 D = 3°28'21"
 T = 1658.18'
 L = 2599.97'
 R = 1650.00'
 PC STA = 548'B'+81.79
 Y = 285138.822
 X = 432916.459
 PT STA = 574'B'+81.76
 Y = 286762.685
 X = 431232.718
 BK = S88°49'16.6"W
 AH = N00°53'43.9"W

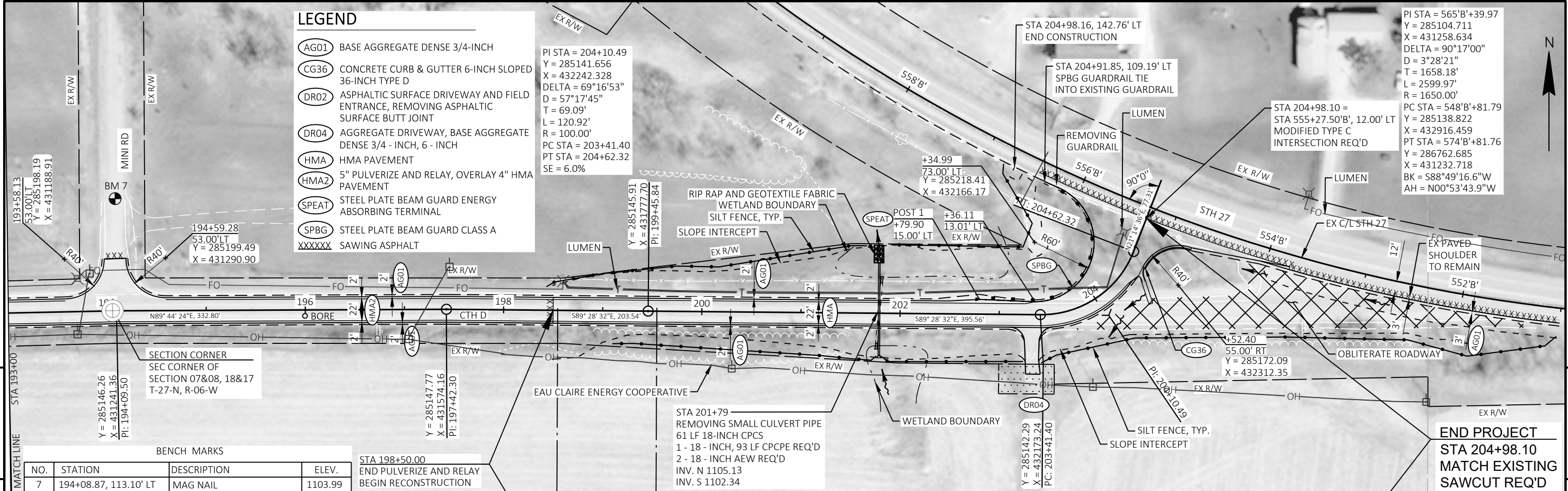

BENCH MARKS

NO.	STATION	DESCRIPTION	ELEV.
7	194+08.87, 113.10' LT	MAG NAIL	1103.99

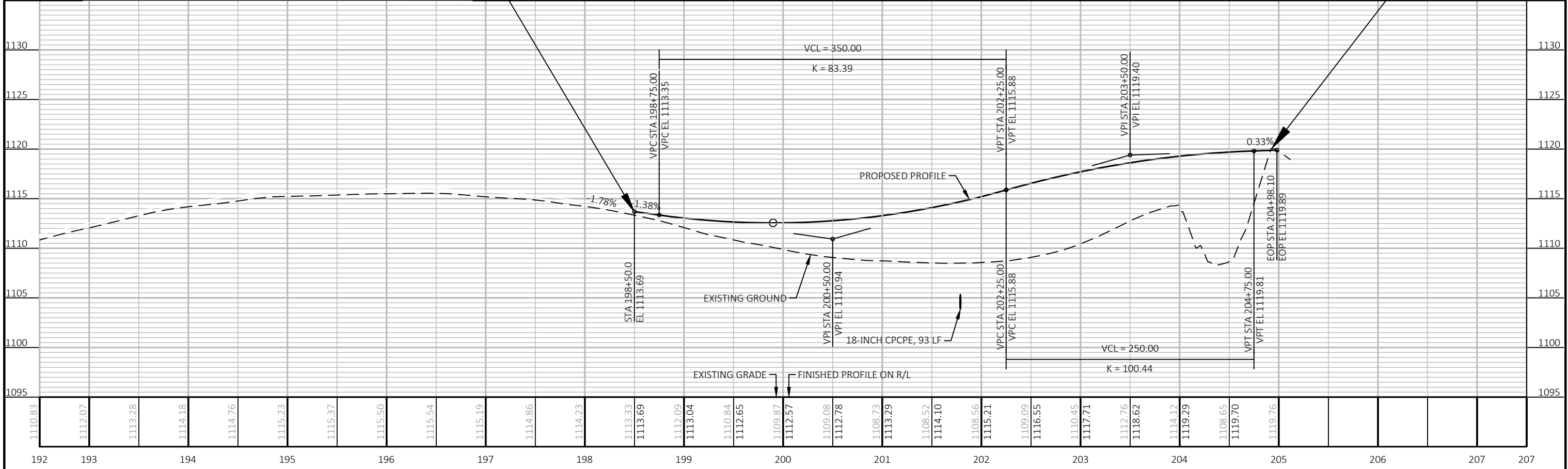

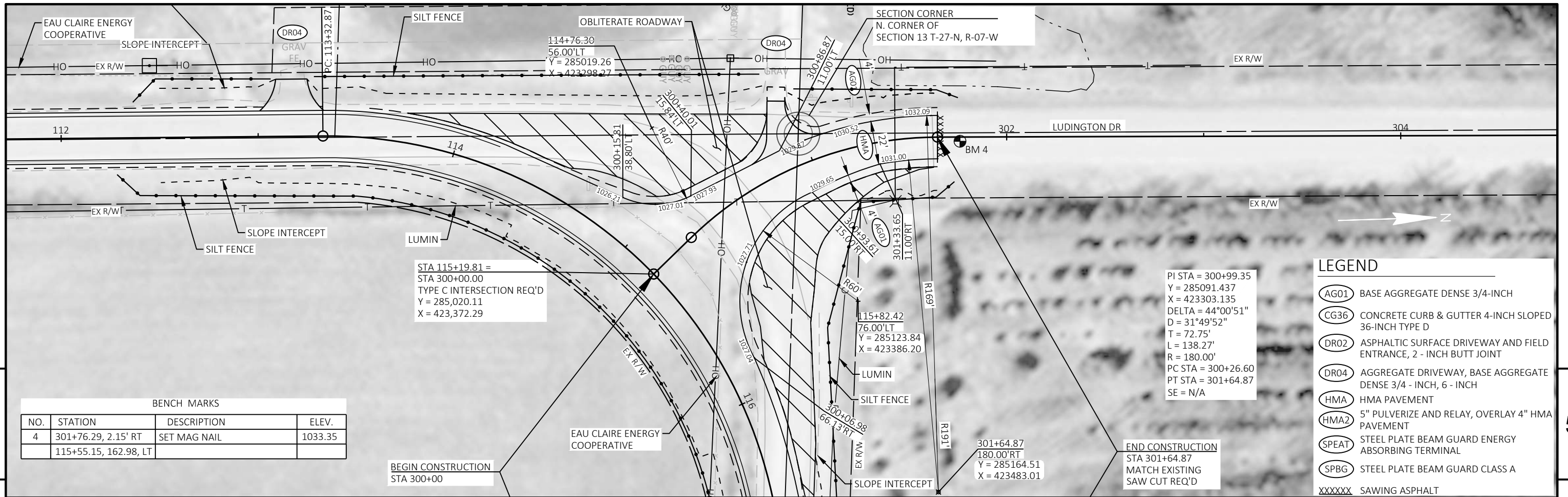

STA 115+19.81 =
 STA 300+00.00
 TYPE C INTERSECTION REQ'D
 Y = 285,020.11
 X = 423,372.29

PI STA = 300+99.35
 Y = 285091.437
 X = 423303.135
 DELTA = 44°00'51"
 D = 31°49'52"
 T = 72.75'
 L = 138.27'
 R = 180.00'
 PC STA = 300+26.60
 PT STA = 301+64.87
 SE = N/A

LEGEND

- AG01 BASE AGGREGATE DENSE 3/4-INCH
- CG36 CONCRETE CURB & GUTTER 4-INCH SLOPED 36-INCH TYPE D
- DR02 ASPHALTIC SURFACE DRIVEWAY AND FIELD ENTRANCE, 2 - INCH BUTT JOINT
- DR04 AGGREGATE DRIVEWAY, BASE AGGREGATE DENSE 3/4 - INCH, 6 - INCH
- HMA HMA PAVEMENT
- HMA2 5" PULVERIZE AND RELAY, OVERLAY 4" HMA PAVEMENT
- SPEAT STEEL PLATE BEAM GUARD ENERGY ABSORBING TERMINAL
- SPBG STEEL PLATE BEAM GUARD CLASS A
- XXXXXX SAWING ASPHALT

BENCH MARKS

NO.	STATION	DESCRIPTION	ELEV.
4	301+76.29, 2.15' RT	SET MAG NAIL	1033.35
	115+55.15, 162.98, LT		

BEGIN CONSTRUCTION
 STA 300+00

END CONSTRUCTION
 STA 301+64.87
 MATCH EXISTING
 SAW CUT REQ'D

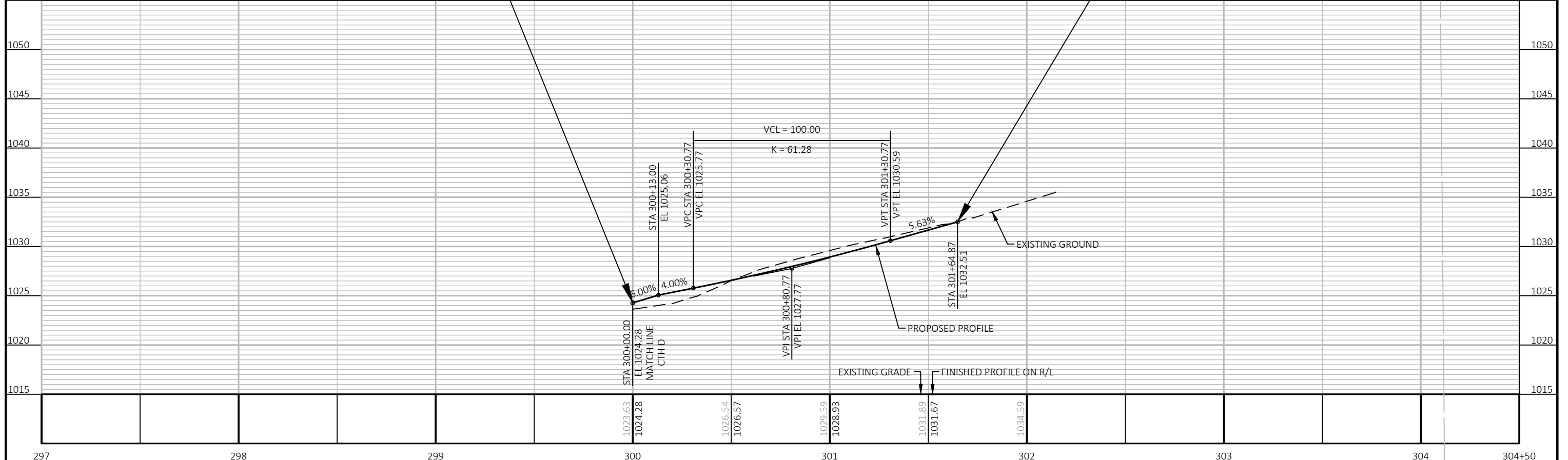

Standard Detail Drawing List

08D01-22A	CONCRETE CURB & GUTTER
08D01-22B	CONCRETE CURB, TIES AND CURB AND GUTTER APPLICATIONS
08D04-06	CONCRETE SURFACE DRAINS & ASPHALTIC FLUMES
08E09-06	SILT FENCE
08E15-01	CULVERT PIPE CHECK
08F01-11	APRON ENDWALLS FOR CULVERT PIPE
09A01-13A	AT-GRADE SIDE ROAD INTERSECTION, TYPES "B1", "B2", "C" AND D AND TEE INTERSECTION BYPASS LANE
09A01-13B	AT-GRADE SIDE ROAD INTERSECTION, TYPE "A1" & "A2"
14B15-11A	STEEL PLATE BEAM GUARD, CLASS "A" INSTALLATION & ELEMENTS
14B15-11B	STEEL PLATE BEAM GUARD, CLASS "A" INSTALLATION & ELEMENTS
14B15-11C	STEEL PLATE BEAM GUARD, CLASS "A", INSTALLATION & ELEMENTS
14B24-09A	STEEL PLATE BEAM GUARD ENERGY ABSORBING TERMINAL
14B24-09B	STEEL PLATE BEAM GUARD ENERGY ABSORBING TERMINAL
14B24-09C	STEEL PLATE BEAM GUARD ENERGY ABSORBING TERMINAL
15A03-02A	FLEXIBLE MARKER POST FOR CULVERT END
15A03-02B	FLEXIBLE MARKER POST FOR CULVERT END
15C02-08A	BARRICADES AND SIGNS FOR MAINLINE CLOSURES
15C02-08C	DETOUR SIGNING FOR MAINLINE CLOSURES
15C04-05	TRAFFIC CONTROL, ADVANCE WARNING SIGNS 45 M. P. H. OR GREATER TWO-WAY UNDIVIDED ROAD OPEN TO TRAFFIC
15C08-20A	LONGITUDINAL MARKING (MAINLINE)
15C12-08	TRAFFIC CONTROL FOR LANE CLOSURE WITH FLAGGING OPERATION
15C35-04A	PAVEMENT MARKING (INTERSECTIONS)

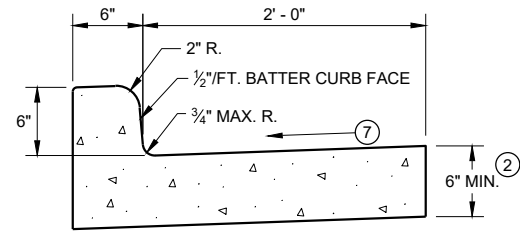

TYPES A^① & D

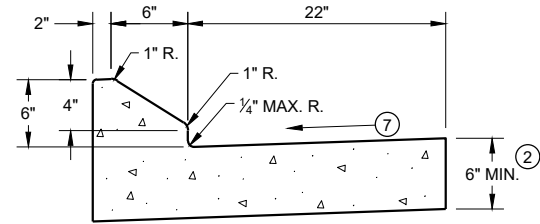

6" SLOPED CURB TYPES G^① & J

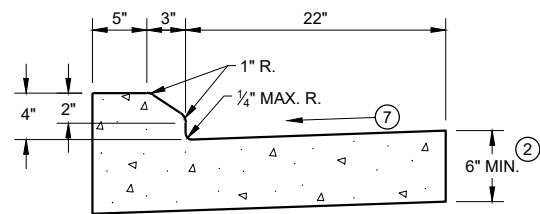

4" SLOPED CURB TYPES G^① & J

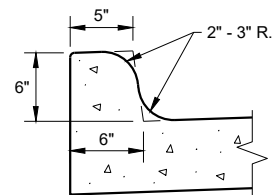

TYPES K^① & L
(OPTIONAL CURB SHAPE)

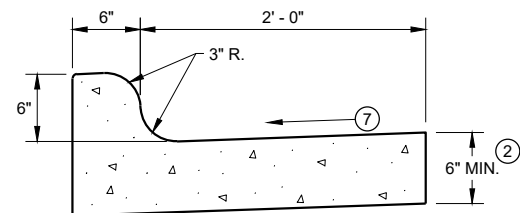

TYPES K^① & L
CONCRETE CURB AND GUTTER 30"

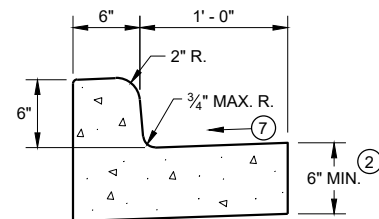

TYPES A^① & D
CONCRETE CURB AND GUTTER 18"

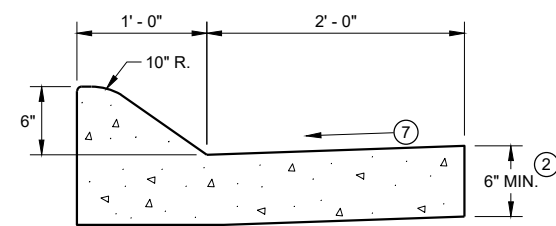

6" SLOPED CURB TYPES A^① & D

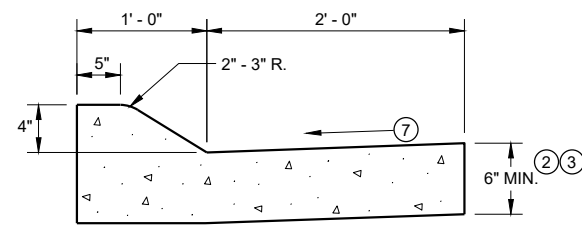

4" SLOPED CURB TYPES A^① & D
CONCRETE CURB AND GUTTER 36"

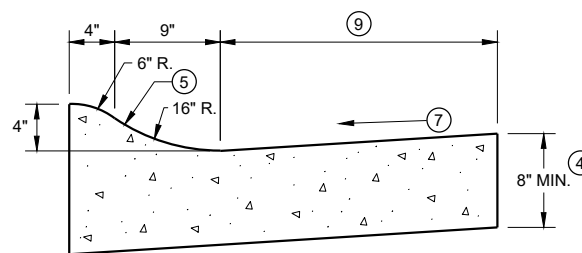

4" SLOPED CURB TYPES R^① & T

TBT & TBTT	X
30"	22"
36"	28"

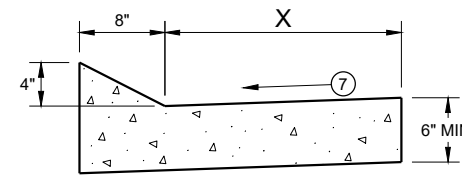

TYPES TBT & TBTT^①
CONCRETE CURB AND GUTTER

PAVEMENT THICKNESS
AND MAXIMUM CONCRETE
PANEL WIDTH TABLE

PAVEMENT THICKNESS	MAXIMUM PANEL WIDTH
LESS THAN 10"	12'
10" & ABOVE	15'

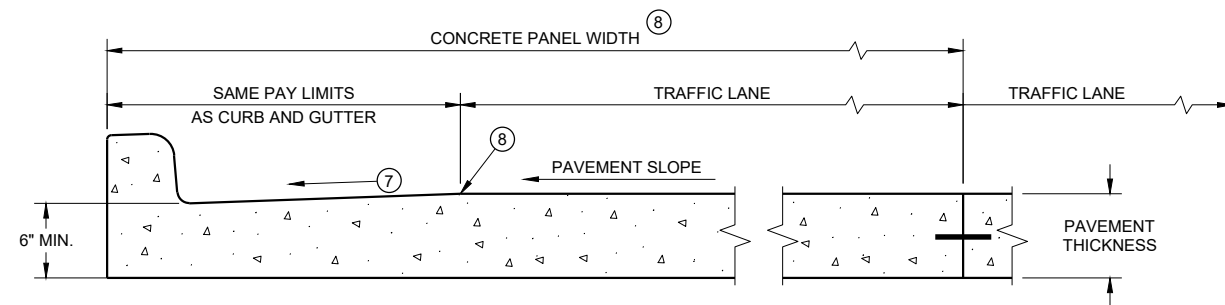

PARTIAL SECTION OF PAVEMENT *
WITH INTEGRAL CURB AND GUTTER

* BIKE LANE IS NOT SHOWN

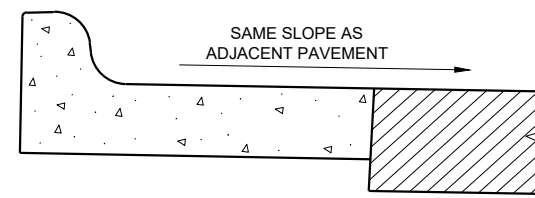

REVERSE SLOPE GUTTER^⑥
(TYPICAL FOR ALL CURB & GUTTER TYPES)

GENERAL NOTES

DETAILS OF CONSTRUCTION AND WORKMANSHIP NOT SHOWN ON THIS DRAWING SHALL CONFORM TO THE PERTINENT REQUIREMENTS OF THE CONTRACT.

PAVEMENT TIES AND TIE BARS SHALL BE EPOXY COATED IN CONFORMANCE WITH SUBSECTION 505.2.6.2 OF THE STANDARD SPECIFICATIONS.

INTEGRAL CURB AND GUTTER SHALL CONFORM TO THE DETAILS SHOWN FOR CONCRETE CURB AND GUTTER INCLUDING THE TRANSVERSE GUTTER SLOPE.

UNLESS OTHERWISE SHOWN ON THE TYPICAL CROSS SECTIONS, THE BASE AGGREGATE AND COMMON EXCAVATION LIMITS ARE 2' - 0" BEHIND THE BACK OF CURBS.

- ① TIE BARS ARE REQUIRED FOR CURB AND GUTTERS TYPES A, G, K, R, AND TBTT.
- ② THE BOTTOM OF CURB AND GUTTER MAY BE CONSTRUCTED EITHER LEVEL OR PARALLEL TO THE SLOPE OF THE SUBGRADE OR BASE AGGREGATE PROVIDED A 6" MINIMUM GUTTER THICKNESS IS MAINTAINED.
- ③ USE 8" MINIMUM GUTTER THICKNESS WHEN USED WITH AN ADJACENT CONCRETE TRUCK APRON PLACED BEHIND BACK OF CURB.
- ④ THE BOTTOM OF CURB AND GUTTER MAY BE CONSTRUCTED EITHER LEVEL OR PARALLEL TO THE SLOPE OF THE SUBGRADE OR BASE AGGREGATE PROVIDED A 8" MINIMUM GUTTER THICKNESS IS MAINTAINED.
- ⑤ UNLESS OTHERWISE NOTED, FOR STAKING PURPOSES THE FACE OF CURB IS 6" FROM THE BACK OF CURB.
- ⑥ WHEN REVERSE SLOPE GUTTER IS REQUIRED, THE LOCATION(S) WILL BE SHOWN ELSEWHERE IN THE PLAN.
- ⑦ USE 4% GUTTER CROSS SLOPE UNLESS OTHERWISE NOTED IN THE PLANS.
- ⑧ INCLUDE LONGITUDINAL JOINT AND TIE BARS ALONG LANE EDGE WHEN CONCRETE PANEL WIDTH EXCEEDS THE MAXIMUM WIDTH PER TABLE BELOW. LONGITUDINAL JOINT(S) ARE NOT ALLOWED WITHIN TRAFFIC LANES AND BIKE LANES. LONGITUDINAL JOINT MAY BE SAWED.
- ⑨ CONCRETE CURB AND GUTTER 4-INCH SLOPED 30-INCH TYPE "R" AND "T" = 17 INCHES
CONCRETE CURB AND GUTTER 4-INCH SLOPED 36-INCH TYPE "R" AND "T" = 23 INCHES

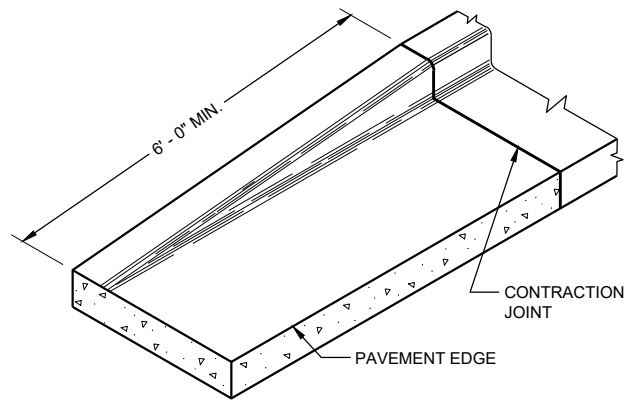

END SECTION CURB AND GUTTER

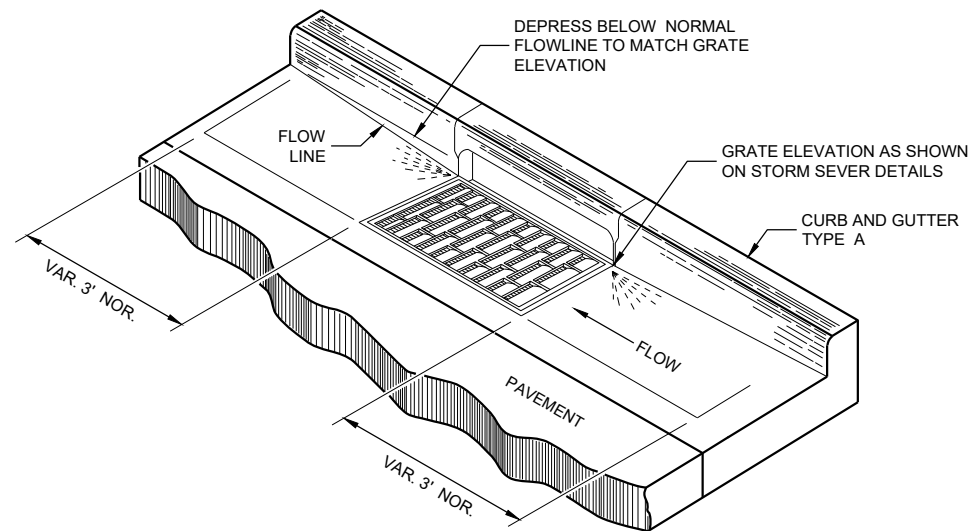

DETAIL OF CURB AND GUTTER AT INLETS
(TYPICAL H INLET COVER SHOWN)

GENERAL NOTES

DETAILS OF CONSTRUCTION AND WORKMANSHIP NOT SHOWN ON THIS DRAWING SHALL CONFORM TO THE PERTINENT REQUIREMENTS OF THE CONTRACT.

PAVEMENT TIES AND TIE BARS SHALL BE EPOXY COATED IN CONFORMANCE WITH SUBSECTION 505.2.6.2 OF THE STANDARD SPECIFICATIONS.

UNLESS OTHERWISE SHOWN ON THE TYPICAL CROSS SECTIONS, THE BASE AGGREGATE AND COMMON EXCAVATION LIMITS ARE 2' - 0" BEHIND THE BACK OF CURBS.

- ① TIE BARS ARE REQUIRED FOR CURB AND GUTTERS TYPES A, G, K, R, AND TBTT.
- ② THE BOTTOM OF CURB AND GUTTER MAY BE CONSTRUCTED EITHER LEVEL OR PARALLEL TO THE SLOPE OF THE SUBGRADE OR BASE AGGREGATE PROVIDED A 6" MINIMUM GUTTER THICKNESS IS MAINTAINED.
- ⑨ REFER TO SDD 08D18 AND 08D19 FOR ADDITIONAL DRIVEWAY ENTRANCE CURB DETAILS.

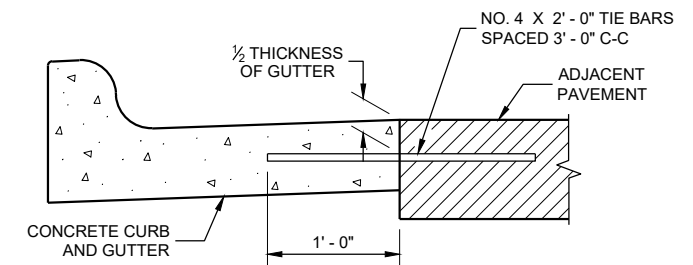

TYPICAL TIE BAR LOCATION ①

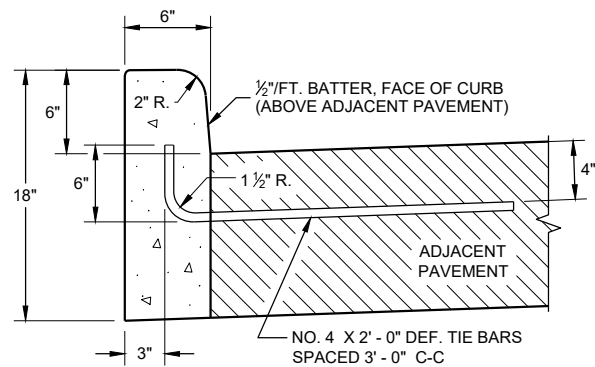

TYPES A ① & D

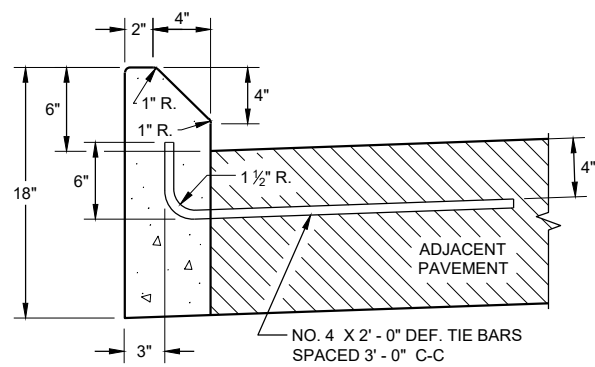

TYPES G ① & J

CONCRETE CURB

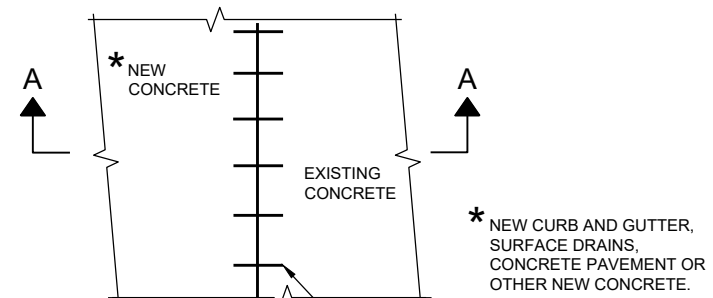

PLAN VIEW

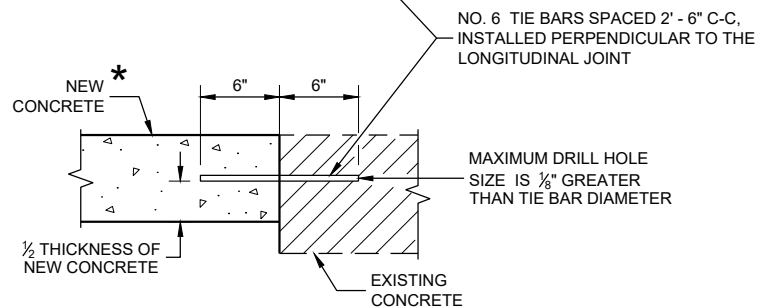

SECTION A - A

TIE BARS DRILLED INTO EXISTING PAVEMENT

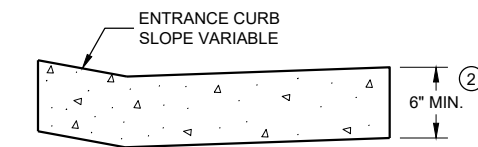

DRIVEWAY ENTRANCE CURB ⑨
(WHEN DIRECTED BY THE ENGINEER)

CONCRETE CURB, TIES AND CURB AND GUTTER APPLICATIONS

STATE OF WISCONSIN
DEPARTMENT OF TRANSPORTATION

APPROVED
February 2021 /S/ Rodney Taylor
DATE ROADWAY STANDARDS DEVELOPMENT
ENGINEER

FHWA

NOTE: TAPER CURB ENDS TO GUTTER IN 1' - 0"

ASPHALTIC FLUME

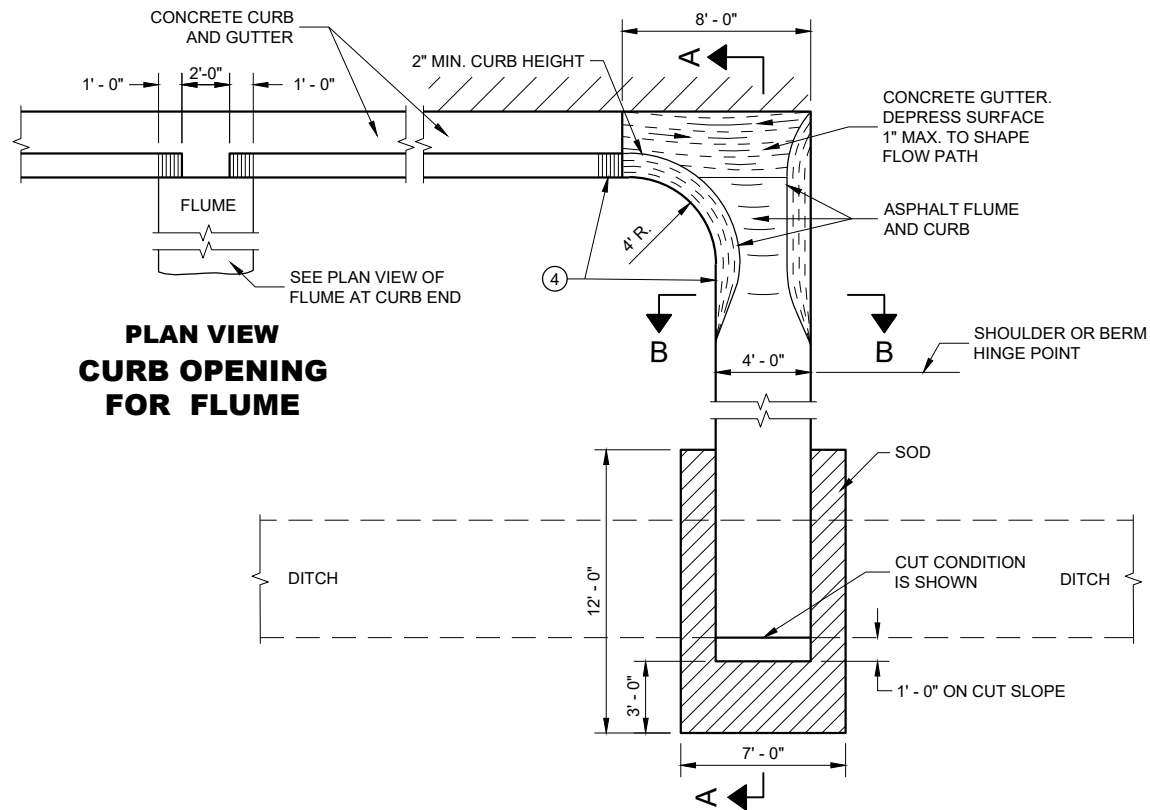

**PLAN VIEW
CURB OPENING
FOR FLUME**

**PLAN VIEW
FLUME AT CURB END**

GENERAL NOTES

DETAILS OF CONSTRUCTION, MATERIALS AND WORKMANSHIP NOT SHOWN ON THIS DRAWING SHALL CONFORM TO PERTINENT REQUIREMENTS OF THE STANDARD SPECIFICATIONS AND APPLICABLE SPECIAL PROVISIONS.

4" X 4" - W3.0 X W3.0 CONCRETE REINFORCEMENT SHALL BE IN ACCORDANCE WITH AASHTO SPECIFICATION M55.

- ① JOINTS SHALL BE 1/8" TO 1/4" WIDE BY 1 1/2" DEEP AND SPACED AT UNIFORM INTERVALS OF APPROXIMATELY 4 FEET.
- ② GEOTEXTILE TYPE "R" SHALL UNDERLAY THE FULL LENGTH AND WIDTH OF THE CONCRETE SURFACE DRAIN AND RIPRAP.
- ③ CONCRETE SURFACE DRAIN WITHOUT CURB AND GUTTER MAY BE USED ON BACKSLOPES WHEN SPECIFIED.
- ④ ANGLE OF FLUME IN RELATION TO BACK OF CURB TO BE CONSTRUCTED PER THE PLAN DETAILS OR AS DIRECTED BY THE ENGINEER. ANGLE OF FLUME MAY BE OTHER THAN 90 DEGREES AS SHOWN.

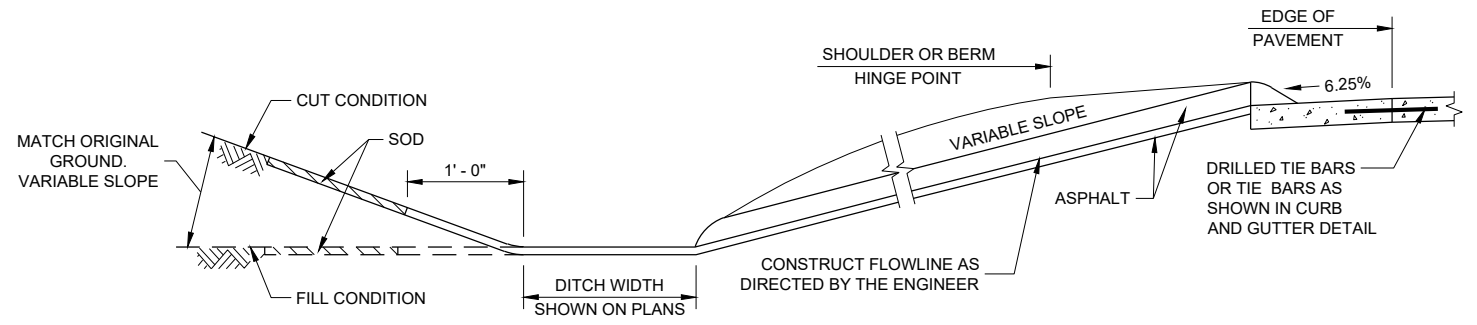

SECTION A - A

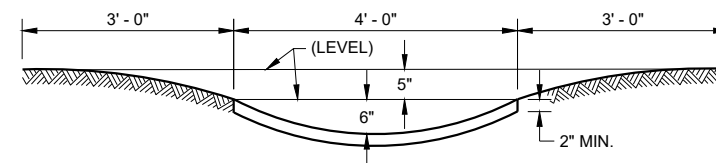

SECTION B - B

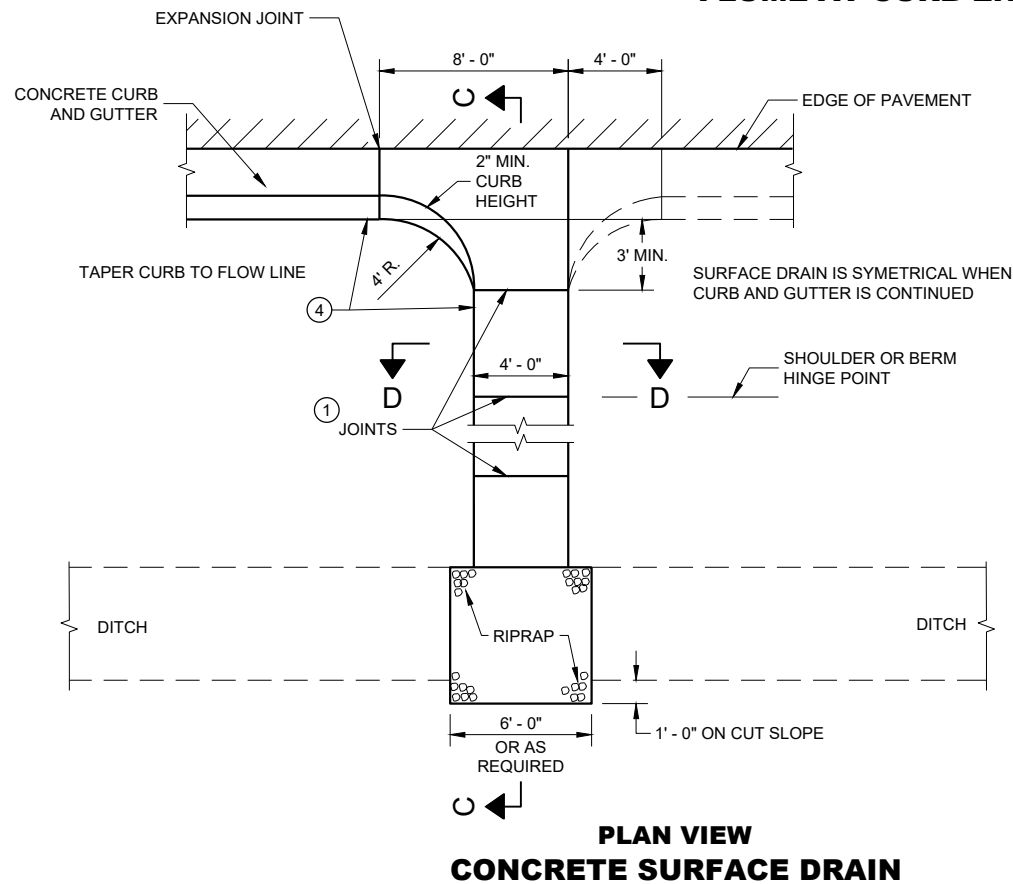

**PLAN VIEW
CONCRETE SURFACE DRAIN**

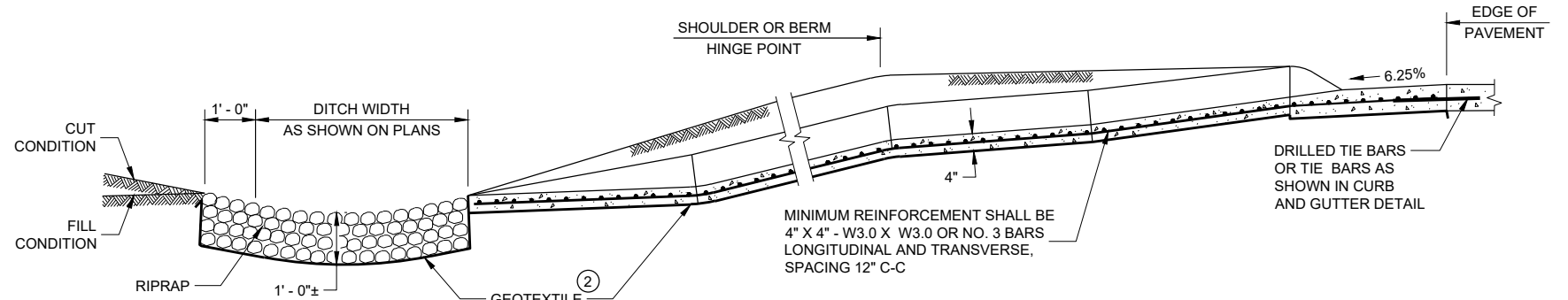

SECTION C - C

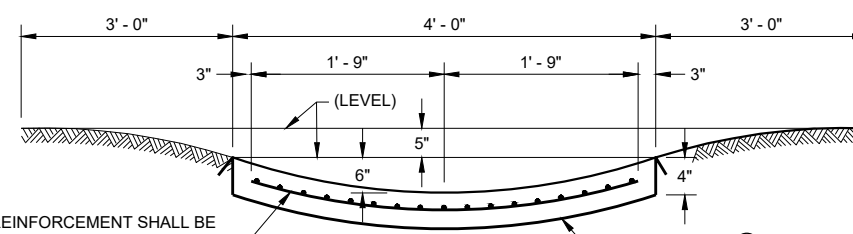

SECTION D - D

MINIMUM REINFORCEMENT SHALL BE 4" X 4" - W3.0 X W3.0 OR NO. 3 BARS LONGITUDINAL AND TRANSVERSE, SPACING 12" C-C

CONCRETE SURFACE DRAINS AND ASPHALTIC FLUMES

STATE OF WISCONSIN
DEPARTMENT OF TRANSPORTATION

APPROVED
November 2021 /S/ Rodney Taylor
DATE ROADWAY STANDARDS DEVELOPMENT
ENGINEER

FHWA

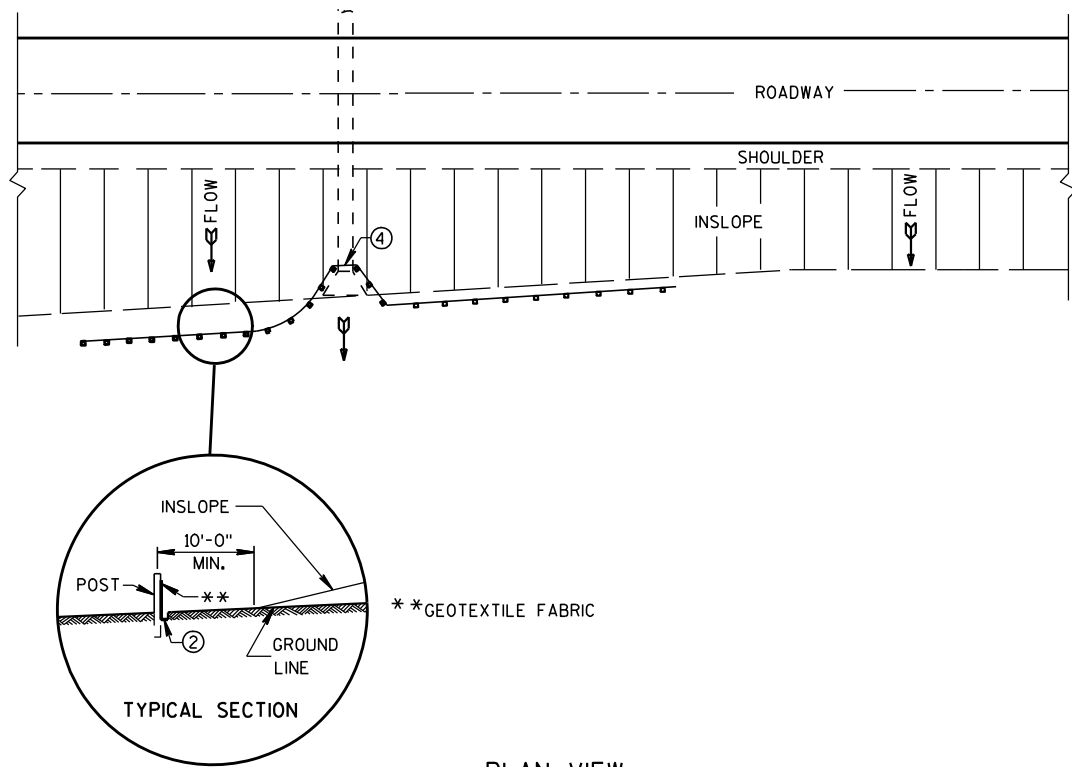

PLAN VIEW
TYPICAL APPLICATION OF SILT FENCE

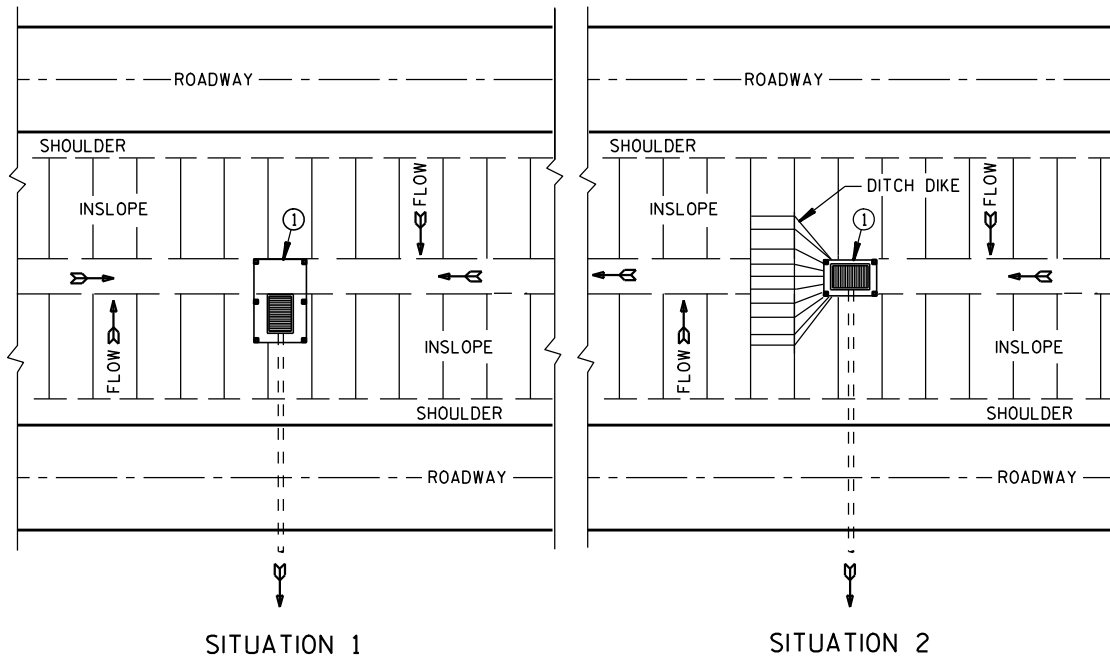

SITUATION 1 SITUATION 2
PLAN VIEW
SILT FENCE AT MEDIAN SURFACE DRAINS

GENERAL NOTES

DETAILS OF CONSTRUCTION NOT SHOWN ON THIS DRAWING SHALL CONFORM TO THE PERTINENT REQUIREMENTS OF THE STANDARD SPECIFICATIONS AND APPLICABLE SPECIAL PROVISIONS.

- ① HORIZONTAL BRACE REQUIRED WITH 2" X 4" WOODEN FRAME OR EQUIVALENT AT TOP OF POSTS.
- ② FOR MANUAL INSTALLATIONS THE TRENCH SHALL BE A MINIMUM OF 4" WIDE & 6" DEEP TO BURY AND ANCHOR THE GEOTEXTILE FABRIC. FOLD MATERIAL TO FIT TRENCH AND BACKFILL & COMPACT TRENCH WITH EXCAVATED SOIL.
- ③ WOOD POSTS SHALL BE A MINIMUM SIZE OF 1 1/8" X 1 1/8" OF OAK OR HICKORY.
- ④ SILT FENCE TO EXTEND ACROSS THE TOP OF THE PIPE.
- ⑤ CONSTRUCT SILT FENCE FROM A CONTINUOUS ROLL IF POSSIBLE BY CUTTING LENGTHS TO AVOID JOINTS. IF A JOINT IS NECESSARY USE ONE OF THE FOLLOWING TWO METHODS; A) OVERLAP THE END POSTS AND TWIST, OR ROTATE, AT LEAST 180 DEGREES, B) HOOK THE END OF EACH SILT FENCE LENGTH.

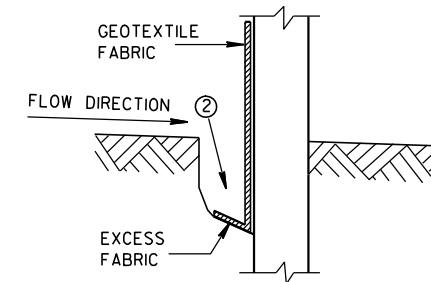

TRENCH DETAIL

NOTE: ADDITIONAL POST DEPTH OR TIE BACKS MAY BE REQUIRED IN UNSTABLE SOILS

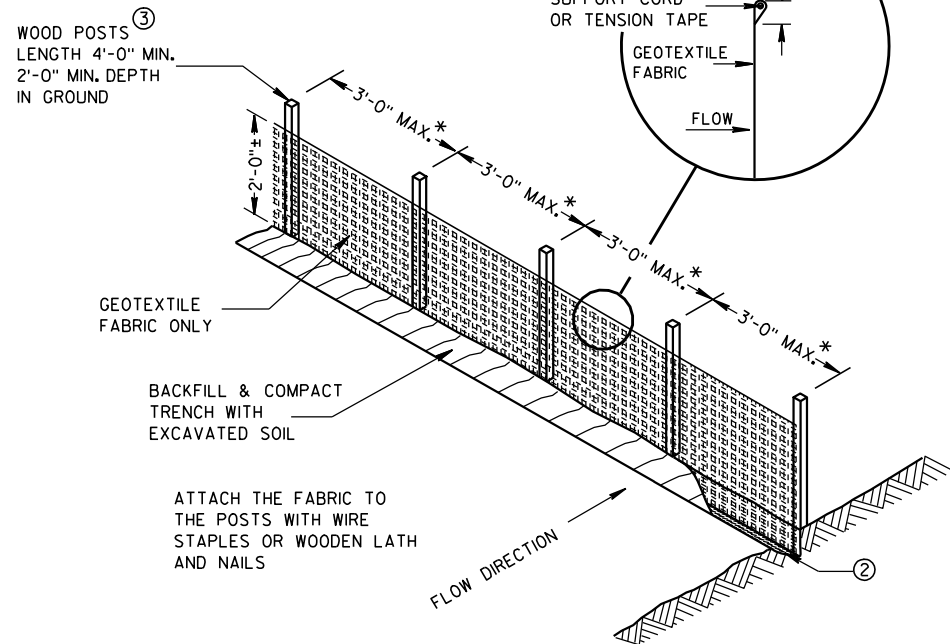

SILT FENCE

* NOTE: 8'-0" POST SPACING ALLOWED IF A WOVEN GEOTEXTILE FABRIC IS USED.

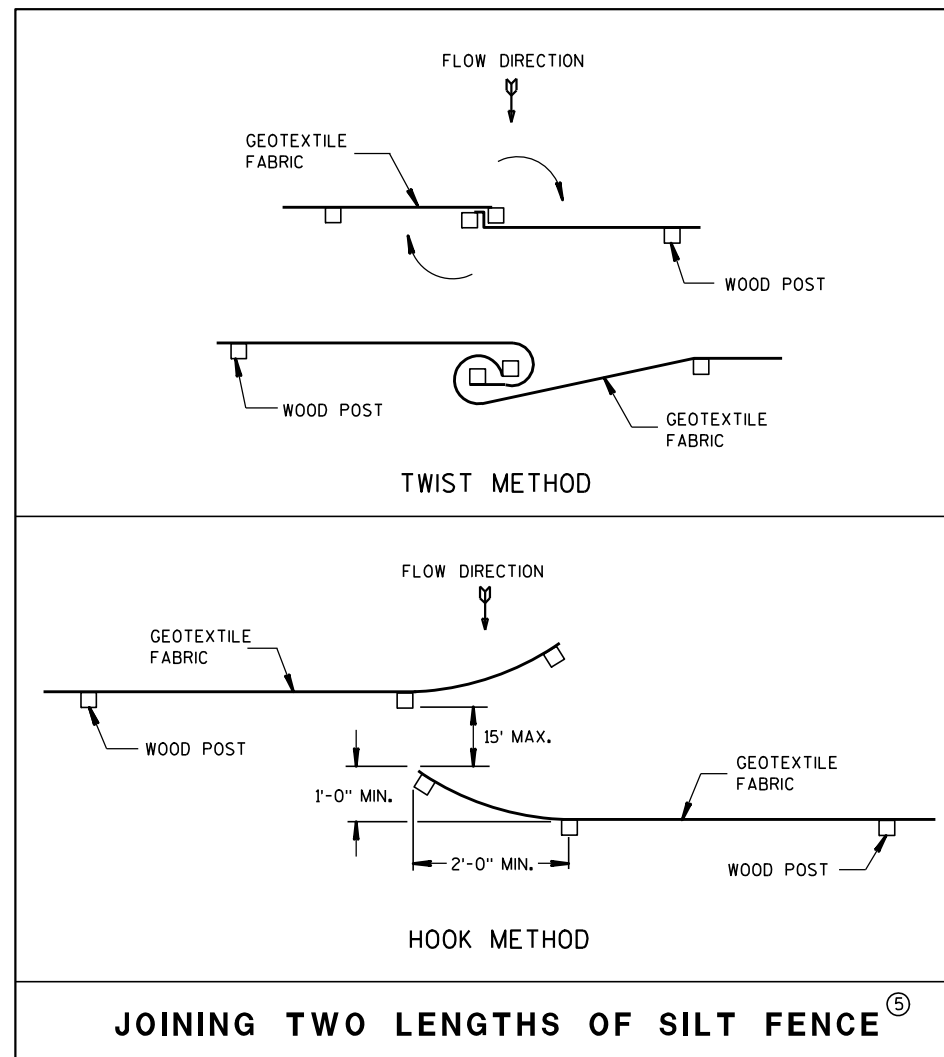

JOINING TWO LENGTHS OF SILT FENCE ⑤

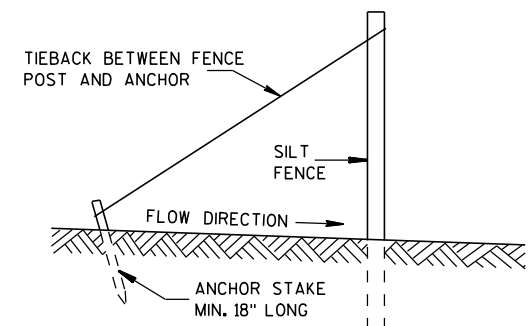

SILT FENCE TIE BACK
(WHEN REQUIRED BY THE ENGINEER)

SILT FENCE

STATE OF WISCONSIN
DEPARTMENT OF TRANSPORTATION

APPROVED

4-29-05

DATE

FHWA

/S/ Beth Cannestra
CHIEF ROADWAY DEVELOPMENT ENGINEER

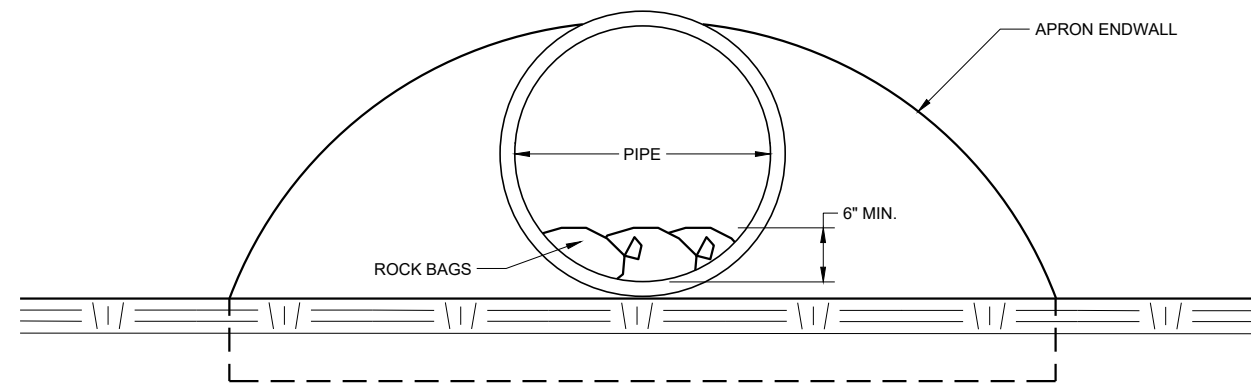

END VIEW

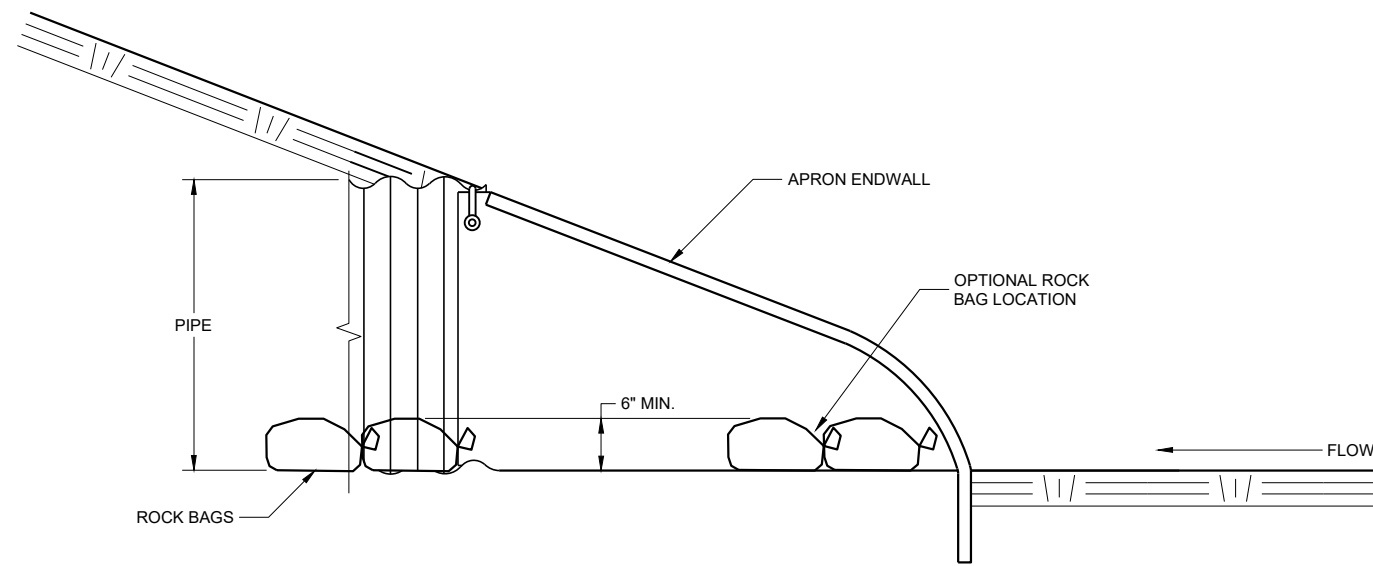

SIDE VIEW

CULVERT PIPE CHECK
(INSTALL ON INLET END ONLY)

CULVERT PIPE CHECK

STATE OF WISCONSIN
DEPARTMENT OF TRANSPORTATION

APPROVED
May 2019 /S/ Daniel Schave
DATE EROSION CONTROL ENGINEER

FHWA

METAL APRON ENDWALLS											
PIPE DIA. (IN.)	MIN. THICK. (Inches)		DIMENSIONS (Inches)							APPROX. SLOPE	BODY
	STEEL	ALUM.	A (±1")	B (MAX.)	H (±1")	L (±1 1/2")	L1	L2	W (±2")		
12	.064	.060	6	6	6	21	12	17 1/2	24	2 1/2 to 1	1 Pc.
15	.064	.060	7	8	6	26	14	21 3/4	30	2 1/2 to 1	1 Pc.
18	.064	.060	8	10	6	31	15	28 1/4	36	2 1/2 to 1	1 Pc.
21	.064	.060	9	12	6	36	18	29 5/8	42	2 1/2 to 1	1 Pc.
24	.064	.075	10	13	6	41	18	37 1/4	48	2 1/2 to 1	1 Pc.
30	.079	.075	12	16	8	51	18	52 1/4	60	2 1/2 to 1	1 Pc.
36	.079	.105	14	19	9	60	24	59 3/4	72	2 1/2 to 1	2 Pc.
42	.109	.105	16	22	11	69	24	75 5/8	84	2 1/2 to 1	2 Pc.
48	.109	.105	18	27	12	78	24	81	90	2 1/4 to 1	3 Pc.
54	.109	.105	18	30	12	84	30	85 1/2	102	2 1/4 to 1	3 Pc.
60	.109x	.105x	18	33	12	87	—	—	114	2 to 1	3 Pc.
66	.109x	.105x	18	36	12	87	—	—	120	2 to 1	3 Pc.
72	.109x	.105x	18	39	12	87	—	—	126	2 to 1	3 Pc.
78	.109x	.105x	18	42	12	87	—	—	132	1 1/2 to 1	3 Pc.
84	.109x	.105x	18	45	12	87	—	—	138	1 1/2 to 1	3 Pc.
90	.109x	.105x	18	37	12	87	—	—	144	1 1/2 to 1	3 Pc.
96	.109x	.105x	18	35	12	87	—	—	150	1 1/2 to 1	3 Pc.

* EXCEPT CENTER PANEL SEE GENERAL NOTES

REINFORCED CONCRETE APRON ENDWALLS									
PIPE DIA. (IN.)	DIMENSIONS (Inches)							APPROX. SLOPE	
	T	A	B	C	D	E	G		
12	2	4	24	48 1/8	72 1/8	24	2	3 to 1	
15	2 1/4	6	27	46	73	30	2 1/4	3 to 1	
18	2 1/2	9	27	46	73	36	2 1/2	3 to 1	
21	2 3/4	9	36	37 1/2	73 1/2	42	2 3/4	3 to 1	
24	3	9 1/2	43 1/2	30	73 1/2	48	3	3 to 1	
27	3 1/4	10 1/2	49 1/2	24	73 1/2	54	3 1/4	3 to 1	
30	3 1/2	12	54	19 3/4	73 1/2	60	3 1/2	3 to 1	
36	4	15	63	34 3/4	97 3/4	72	4	3 to 1	
42	4 1/2	21	63	35	98	78	4 1/2	3 to 1	
48	5	24	72	26	98	84	5	3 to 1	
54	5 1/2	27	65	33 1/4-35	98 1/4-100	90	5 1/2	2 1/2 to 1	
60	6	30-35	60	39	99	96	5	2 to 1	
66	6 1/2	24-30	72-78	21-27	99	102	5 1/2	2 to 1	
72	7	24-36	78	21	99	108	6	2 to 1	
78	7 1/2	24-36	78	21	99	114	6 1/2	2 to 1	
84	8	36	90 1/2	21	111 1/2	120	6 1/2	1 1/2 to 1	
90	8 1/2	41	87 1/2	24	111 1/2	132	6 1/2	1 1/2 to 1	

* MINIMUM
** MAXIMUM

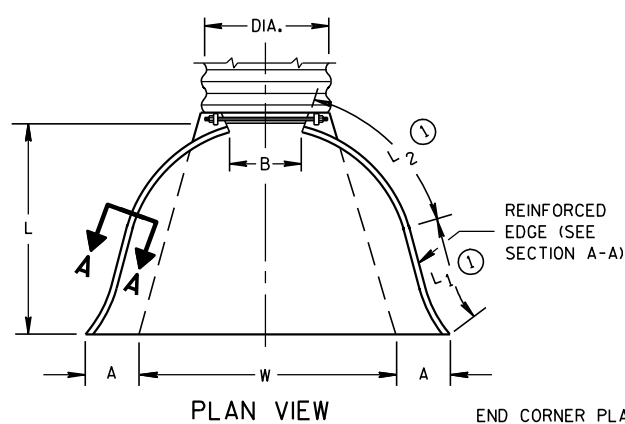

END CORNER PLATES MAY BE FASTENED TO APRON PROPER BY BOLTS, RIVETS, OR RESISTANCE SPOT WELDS WHICH WILL HOLD THE SURFACES TIGHTLY TOGETHER

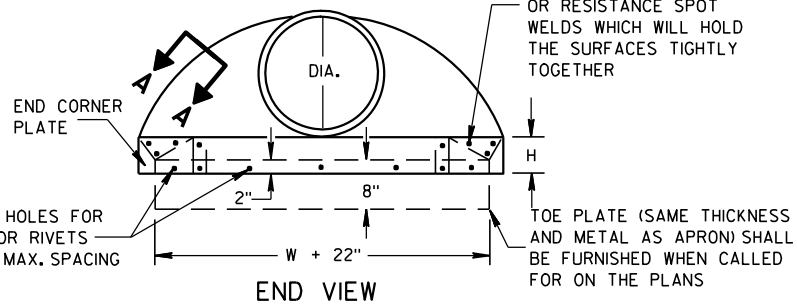

SIDE ELEVATION
METAL ENDWALLS

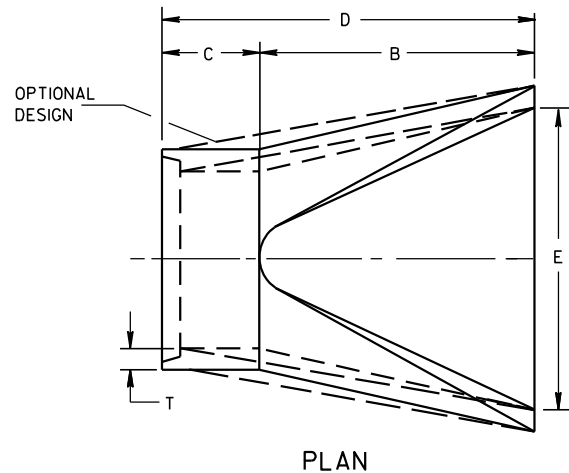

PLAN

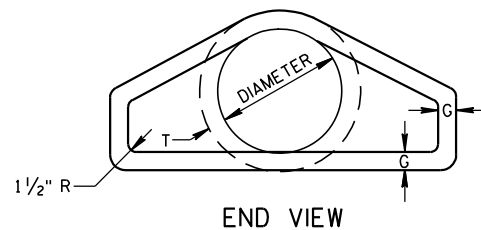

END VIEW

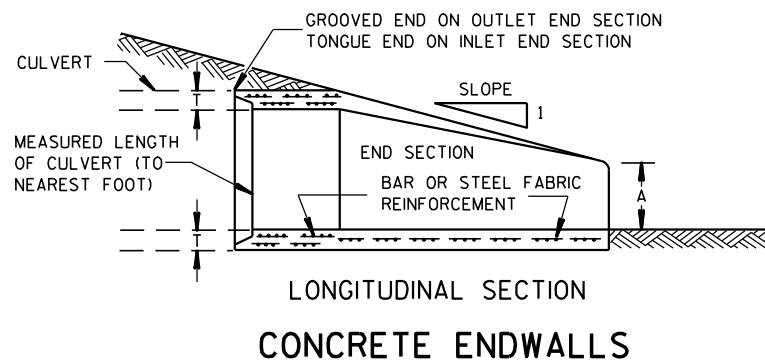

LONGITUDINAL SECTION
CONCRETE ENDWALLS

1" WIDE, 12 GA. (0.109" THICK) GALVANIZED STRAP WITH STANDARD 6" X 1/2" BAND BOLT AND NUT

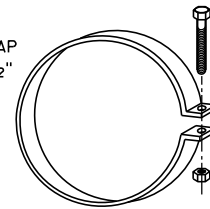

ALTERNATE FOR TYPE 1 CONNECTION
END SECTION CONNECTOR STRAP

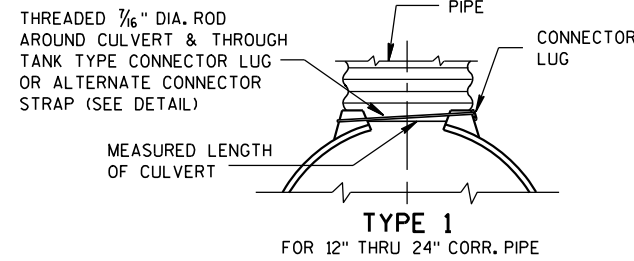

TYPE 1
FOR 12" THRU 24" CORR. PIPE

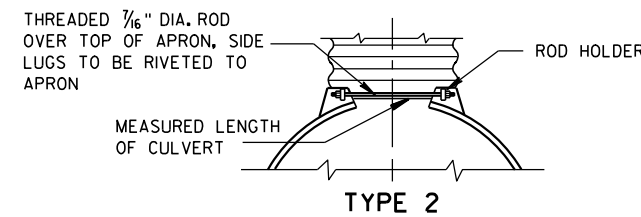

TYPE 2
FOR 30" THRU 96" CORR. PIPE

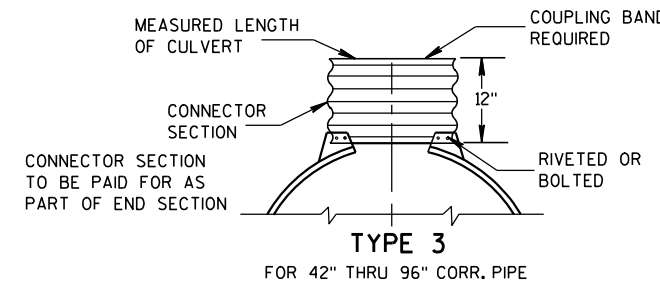

TYPE 3
FOR 42" THRU 96" CORR. PIPE

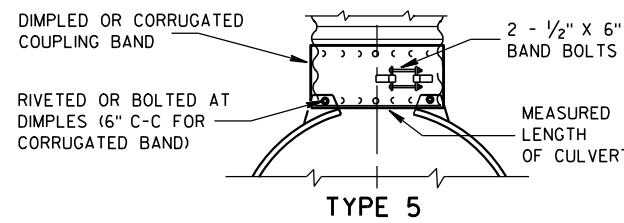

TYPE 5
ALTERNATE FOR:
ALL SIZES CORRUGATED CIRCULAR PIPE

NOTE: DIMPLED BAND FITS OVER OUTSIDE OF ENDWALL, AND CORRUGATED BAND FITS INSIDE ENDWALL. DIMPLED BAND MAY BE USED WITH HELICALLY CORRUGATED PIPE.

FOR CIRCUMFERENTIALLY CORRUGATED PIPE USE ENDWALL CONNECTION DETAILS 1, 2, 3 OR 5 AS APPLICABLE.

FOR HELICALLY CORRUGATED PIPE USE ENDWALL CONNECTION DETAILS 1, 2 OR 5.

FOR HELICALLY CORRUGATED PIPES WITH TWO CIRCUMFERENTIAL CORRUGATIONS AT EACH END USE ENDWALL CONNECTION DETAILS 1, 2 OR 3.

CONNECTION DETAILS

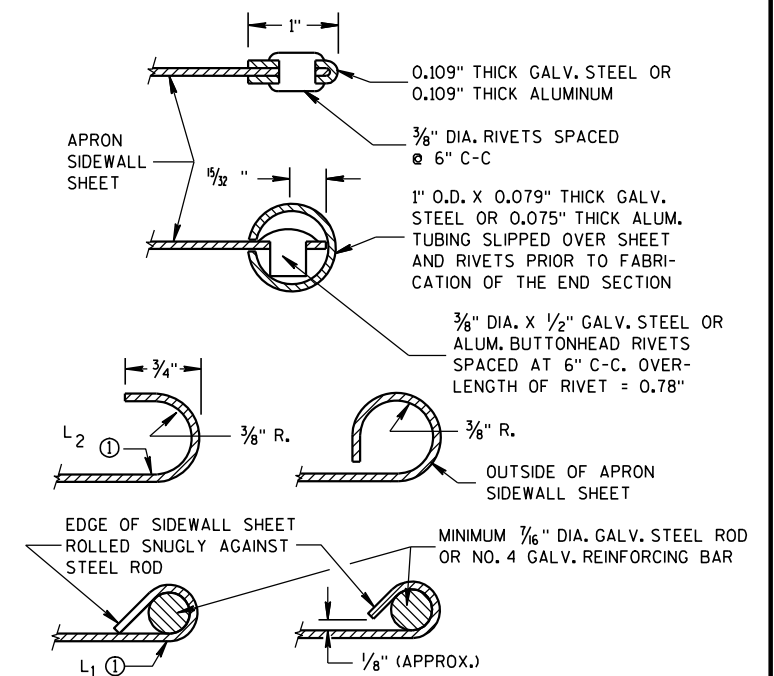

SECTION A-A

GENERAL NOTES

DETAILS OF CONSTRUCTION, MATERIALS AND WORKMANSHIP NOT SHOWN ON THIS DRAWING SHALL CONFORM TO THE PERTINENT REQUIREMENTS OF THE STANDARD SPECIFICATIONS AND THE APPLICABLE SPECIAL PROVISIONS.

CONCRETE CULVERT ENDWALLS MAY NOT BE USED WITH GALVANIZED STEEL OR ALUMINUM CULVERT PIPE OR VICE VERSA. GALVANIZED STEEL OR ALUMINUM ENDWALLS SHALL NORMALLY BE INSTALLED ON CULVERT PIPE OF THE SAME METAL.

ALL THREE PIECE STEEL APRON ENDWALLS FOR 60" DIAMETER PIPE AND LARGER SHALL HAVE 0.109" SIDES AND 0.138" CENTER PANELS. ALL THREE PIECE ALUMINUM APRON ENDWALLS FOR 60" DIAMETER PIPE AND LARGER SHALL HAVE 0.105" SIDES AND 0.134" CENTER PANELS. THE WIDTH OF CENTER PANELS SHALL BE GREATER THAN 20 PERCENT OF THE PIPE PERIMETER.

LAP SEAMS SHALL BE TIGHTLY JOINED BY GALVANIZED RIVETS OR BOLTS FOR STEEL UNITS AND ALUMINUM RIVETS AND BOLTS FOR ALUMINUM UNITS. FOR THE 60" THROUGH 96" DIAMETER APRON ENDWALL SIZES, THE REINFORCED EDGES AND CENTER PANEL SEAMS SHALL BE FURTHER REINFORCED WITH GALVANIZED STEEL OR ALUMINUM STIFFENER ANGLES. THE ANGLES SHALL BE ATTACHED BY GALVANIZED NUTS AND BOLTS FOR STEEL UNITS AND ALUMINUM NUTS AND BOLTS FOR ALUMINUM UNITS.

WHERE TWO OR MORE PIPES WITH APRON ENDWALLS ARE LAID ADJACENT TO EACH OTHER, THEY SHALL BE SEPARATED BY A DISTANCE SUFFICIENT TO PROVIDE A MINIMUM CLEARANCE OF 6 INCHES BETWEEN APRON ENDWALLS.

① FOR PIPE SIZES UP TO 60" DIAMETER, A 180° ROLLED EDGE MAY BE USED INSTEAD OF STEEL ROD REINFORCEMENT. SEE SECTION A-A.

APRON ENDWALLS FOR CULVERT PIPE

STATE OF WISCONSIN
DEPARTMENT OF TRANSPORTATION

APPROVED
11/30/94 /s/ Rory L. Rhinesmith
DATE CHIEF ROADWAY DEVELOPMENT ENGINEER
FHWA

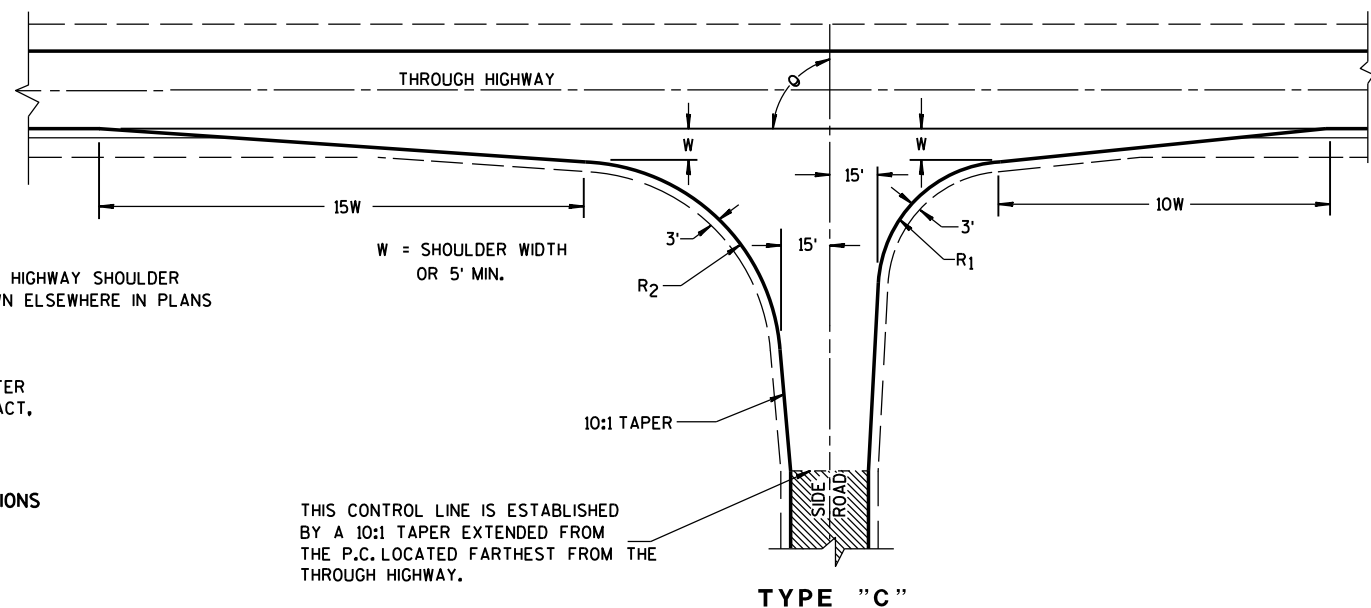
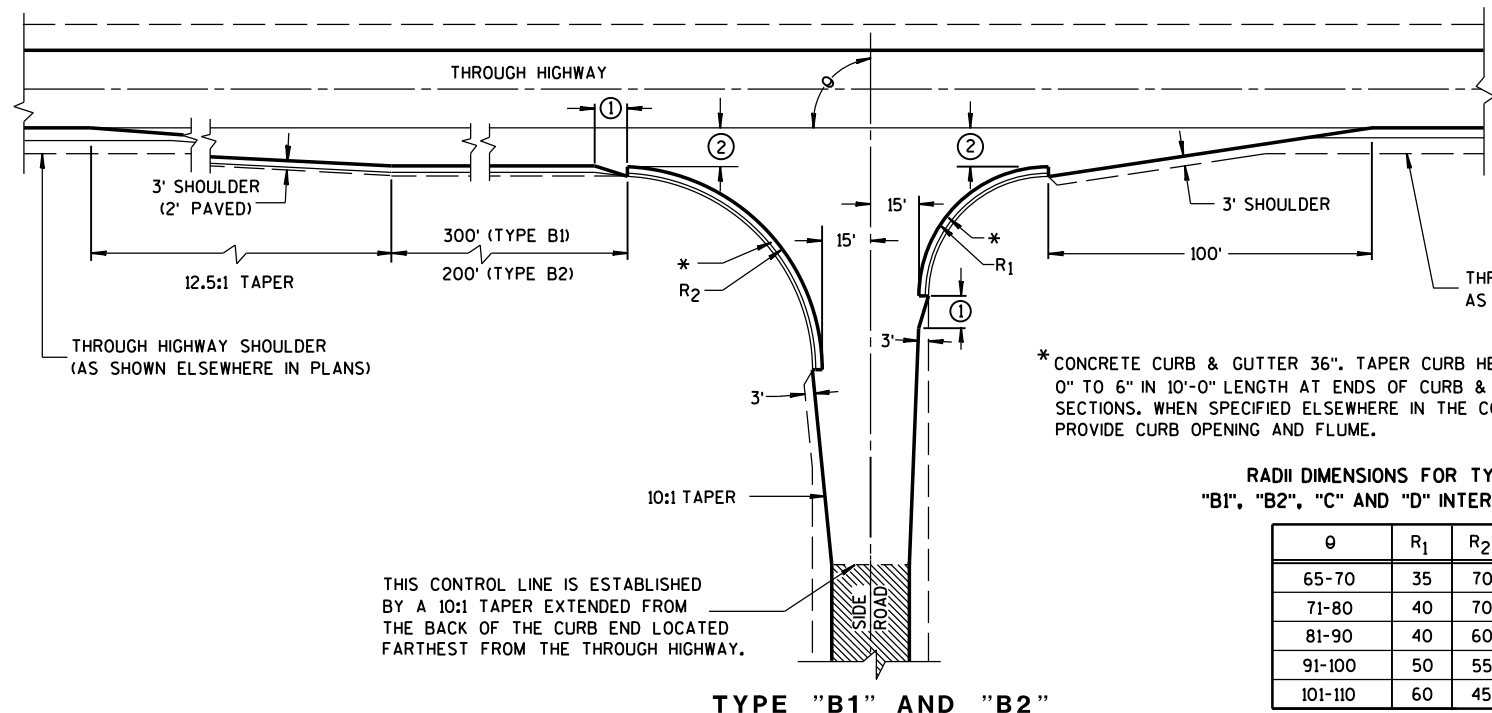

RADII DIMENSIONS FOR TYPES "B1", "B2", "C" AND "D" INTERSECTIONS

θ	R ₁	R ₂
65-70	35	70
71-80	40	70
81-90	40	60
91-100	50	55
101-110	60	45

GENERAL NOTES

DESIGNS MAY BE USED INTERCHANGEABLY IN COMBINATION OR SEPARATELY FOR ANY ONE COMPLETE INTERSECTION DEPENDING UPON INTERSECTION ANGLE AND SURFACING OF EACH APPROACH ROADWAY.

SIDE ROAD SURFACING NOTE

WHEN THE SIDE ROAD IS NOT PRESENTLY PAVED, PAVEMENT SHALL BE PLACED TO THE LIMITS SHOWN UNLESS OTHERWISE PROVIDED IN THE CONTRACT. WHERE THE CONSTRUCTION LIMITS ARE BEYOND THE PAVING LIMITS, CRUSHED AGGREGATE SURFACING SHALL BE PLACED BETWEEN THE PAVING LIMITS AND CONSTRUCTION LIMITS.

WHEN THE SIDE ROAD IS PRESENTLY PAVED, NEW PAVEMENT SHALL BE PLACED TO THE LIMITS OF DESIGN AS SHOWN AND BEYOND, IF NECESSARY, TO MEET EXISTING PAVEMENT.

WHEN THE SIDE ROAD IS THE CONSTRUCTION PROJECT, THE INTERSECTION SURFACING SHALL BE THE SAME AS FOR THE PROJECT.

- EXISTING PAVED SURFACE
- BYPASS LANE

- ① 10-FT TYPICAL.
- ② 12-FT** PLUS ADDITIONAL WIDTH FOR BIKE LANE IF SHOWN ELSEWHERE IN THE PLAN.

**10-FT MAY BE USED ON TYPE B2 ON RESURFACING PROJECTS IF SPECIFIED IN THE CONTRACT.
- ③ BYPASS LANE PAVED SURFACE WIDTH OUTSIDE OF TRAVEL LANE
-ASPHALT = 12-FT PLUS PAVED SHOULDER WIDTH.
-PC CPNCRETE = 13-FT PLUS PAVED SHOULDER WIDTH.
- ④ BYPASS LANE PAVED SHOULDER WIDTH = THE GREATER OF 1-FT OR THE PAVED SHOULDER WIDTH OF THE THROUGH HIGHWAY.

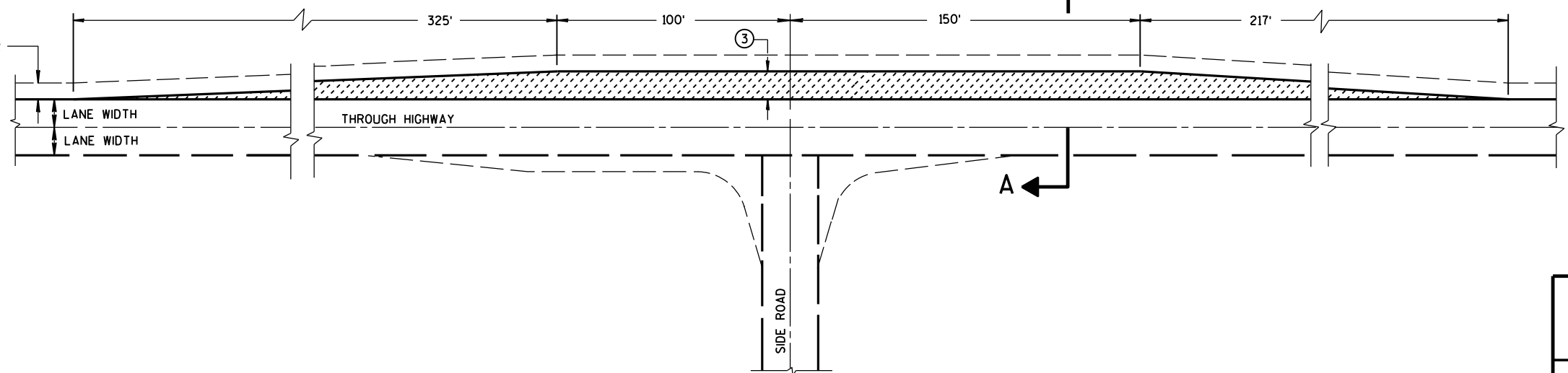
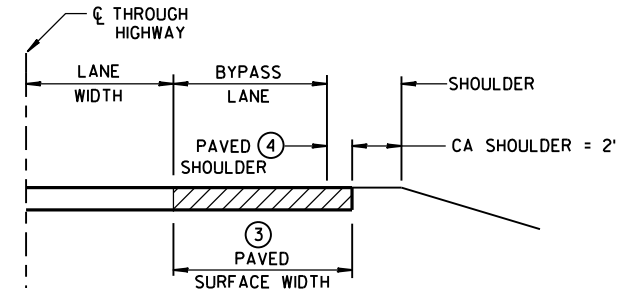
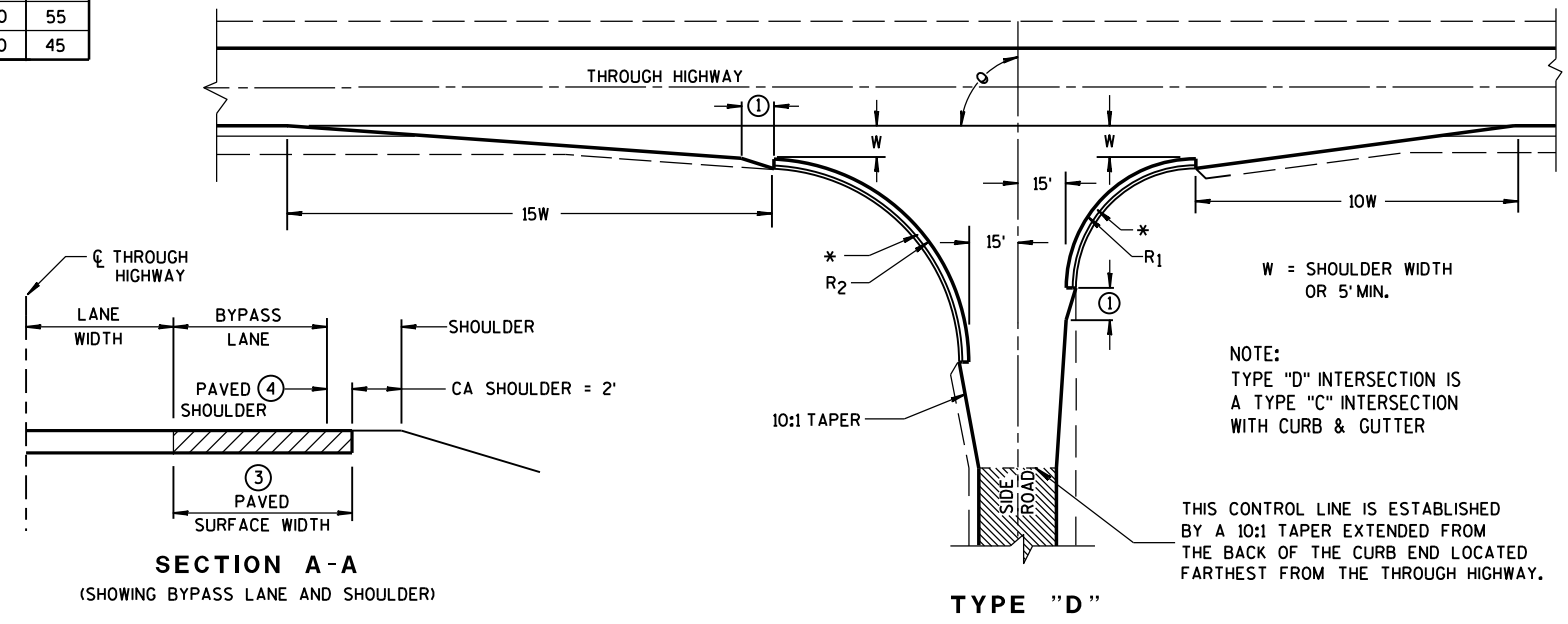

TEE INTERSECTION BYPASS LANE DETAIL

AT-GRADE SIDE ROAD INTERSECTION, TYPES "B1", "B2", "C" AND "D" AND TEE INTERSECTION BYPASS LANE
STATE OF WISCONSIN DEPARTMENT OF TRANSPORTATION

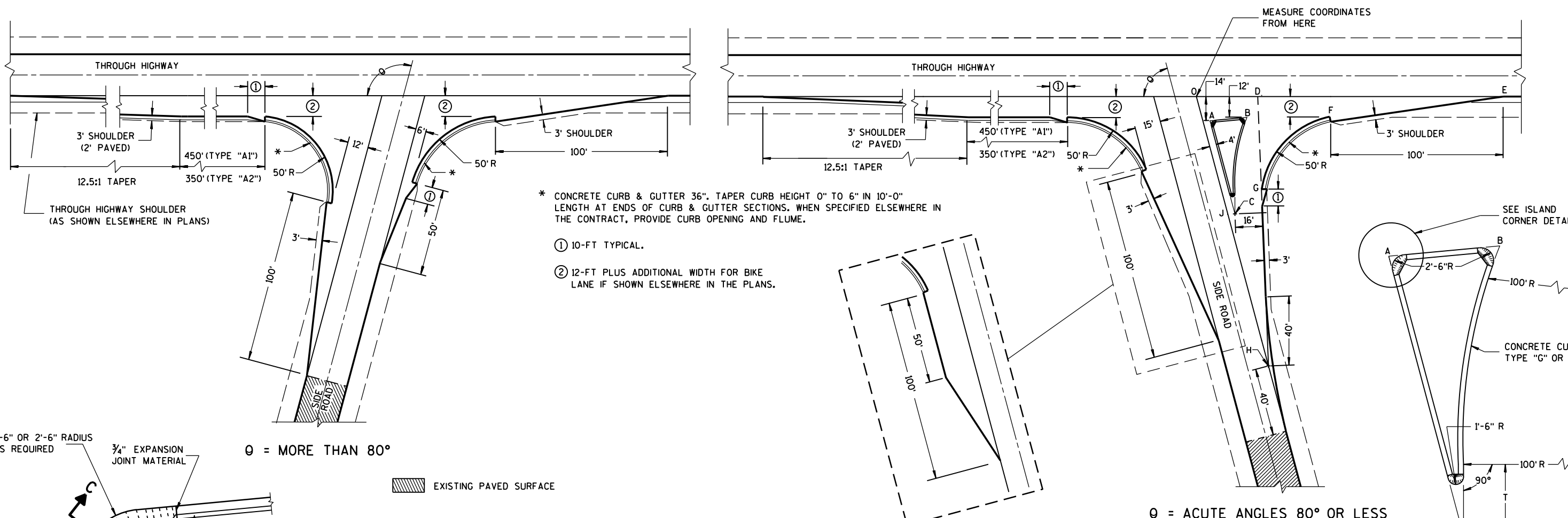

SIDE ROAD WIDENING AND TAPER REQUIRED WHERE THE THROUGH HIGHWAY CARRIES TWO-WAY TRAFFIC
 θ = ACUTE ANGLES 70° OR LESS

TABLE OF DIMENSIONS FOR VARIABLE SIDE ROAD INTERSECTION ANGLES
 (INTERPOLATE VALUES FOR ANGLES NOT SHOWN)

ANGLE θ DEGREES	COORDINATES IN FEET (MEASURED FROM POINT "O")								LENGTH IN FEET				
	A	B	C	D	E	F	G	H	AB	AC	T	OJ	OH
60	12.7	44.9	46.4	41.9	205.0	104.6	64.0	85.0	32.3	67.4	4.9	85.9	169.9
65	10.9	39.0	37.8	39.4	196.1	95.7	54.1	70.5	28.2	63.6	8.5	80.9	166.9
70	9.4	33.9	29.8	37.4	188.3	87.8	45.6	56.1	24.6	59.7	11.5	76.1	164.1
75	7.9	29.3	22.3	35.7	181.2	80.7	38.2	41.8	21.5	55.8	13.8	71.4	161.4
80	6.5	25.4	15.6	34.4	174.8	74.4	31.8	27.6	18.9	52.0	15.6	66.9	158.9

TYPE "A1" & "A2" SIDE ROAD INTERSECTION DETAILS

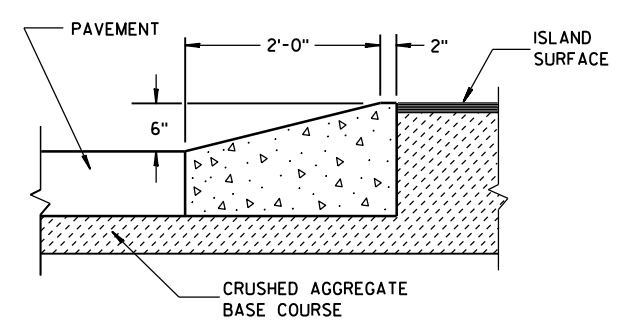
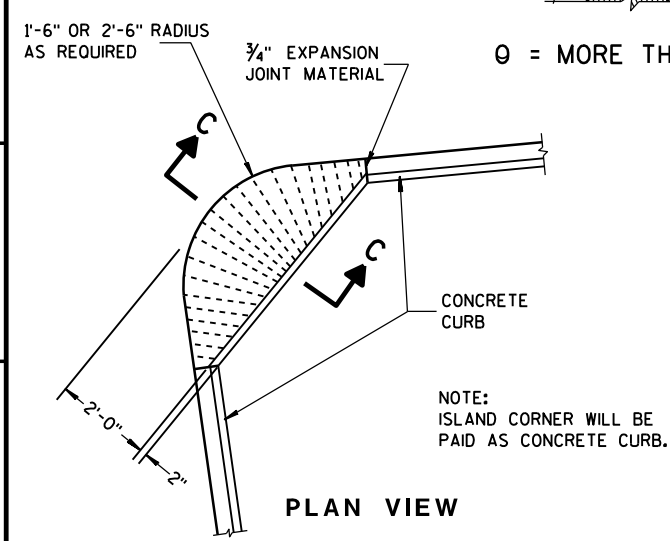

ISLAND CORNER DETAIL
 (TO BE CONSTRUCTED AT ALL ISLAND CORNERS)

AT-GRADE SIDE ROAD INTERSECTION, TYPE "A1" & "A2"

STATE OF WISCONSIN DEPARTMENT OF TRANSPORTATION

APPROVED 12/18/12 /S/ Jerry H. Zogg
 DATE ROADWAY STANDARDS DEVELOPMENT ENGINEER

FHWA

S.D.D. 9 A 1-13b

S.D.D. 9 A 1-13b

GENERAL NOTES

- ① W6 X 9 OR W6 X 8.5 STEEL POSTS AND NOTCHED PLASTIC BLOCKOUTS ARE ACCEPTABLE ALTERNATIVES FOR 6" X 8" WOOD POSTS WITH WOOD OR PLASTIC BLOCKOUTS. USE APPROVED NOTCHED PLASTIC BLOCKOUTS WITH STEEL POSTS. APPROVED PLASTIC BLOCKOUT DESIGNS MAY VARY FROM THIS TYPICAL DETAIL WHEN USED IN CONJUNCTION WITH STEEL POSTS. DO NOT MIX STEEL POSTS AND WOOD POSTS IN A SINGLE INSTALLATION.
- ② USE STRUCTURAL STEEL POSTS CONFORMING TO ASTM A 36. GALVANIZED POSTS ACCORDING TO AASHTO M 111. EITHER SET THE POSTS IN DRILLED HOLES OR DRIVE TO GRADE. REMOVE MUSHROOMING CAUSED BY DRIVING AND REPAIR DAMAGED SPELTER COATING ON GALVANIZED POSTS.
- ③ INSTALL STEEL POSTS WITH HOLES ON APPROACHING TRAFFIC SIDE.
- ④ USE EITHER WOOD OR APPROVED PLASTIC BLOCKOUTS ON WOOD POSTS.
- ⑤ IF THE DISTANCE FROM BACK OF POST TO SHOULDER HINGE POINT IS LESS THAN 2 FEET INSTALL LONGER POST AT HALF POST SPACING, W BEAM (LHW).
- ⑥ IF ROCK IS ENCOUNTERED DURING EXCAVATION, THE ENGINEER MAY APPROVE USING A 12 INCH DIAMETER POST HOLE EXTENDING 20 INCHES DEEP INTO THE ROCK. PLACE GRANULAR MATERIAL IN THE BOTTOM OF THE HOLE APPROXIMATELY 2 1/2 INCHES DEEP. CUT THE POSTS TO LENGTH AND PLACE IN THE HOLE. BACKFILL WITH MATERIAL EXCAVATED FROM THE HOLE AND COMPACT ADEQUATELY.
- ⑦ WHEN USING STEEL POSTS AND WOOD BLOCKOUTS INSTALL FOUR 16D GALVANIZED NAILS. INSTALL NAILS AT THE BACK CORNERS OF THE BLOCK AND BEND THE NAILS OVER THE FLANGE OF THE STEEL POST.

INSTALL BEAM GUARD SECTIONS AND ALL NECESSARY HARDWARE ACCORDING TO THE APPLICABLE PLAN AND CURRENT STANDARD AND SUPPLEMENTAL SPECIFICATIONS. ALL DIMENSIONS ARE SUBJECT TO MANUFACTURER'S TOLERANCES EXCEPT WHERE ALLOWABLE TOLERANCES ARE SHOWN.

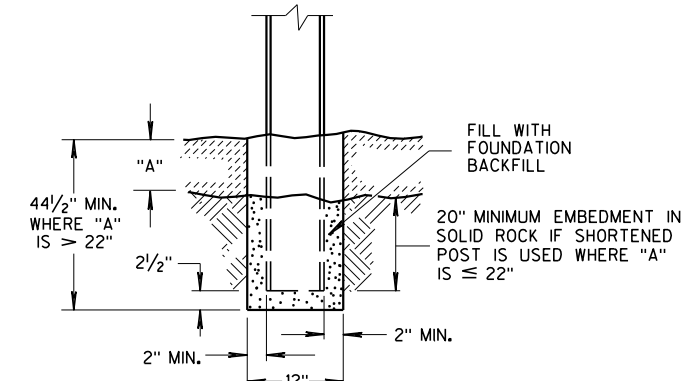

END VIEW SETTING STEEL OR WOOD POST IN ROCK ⑥

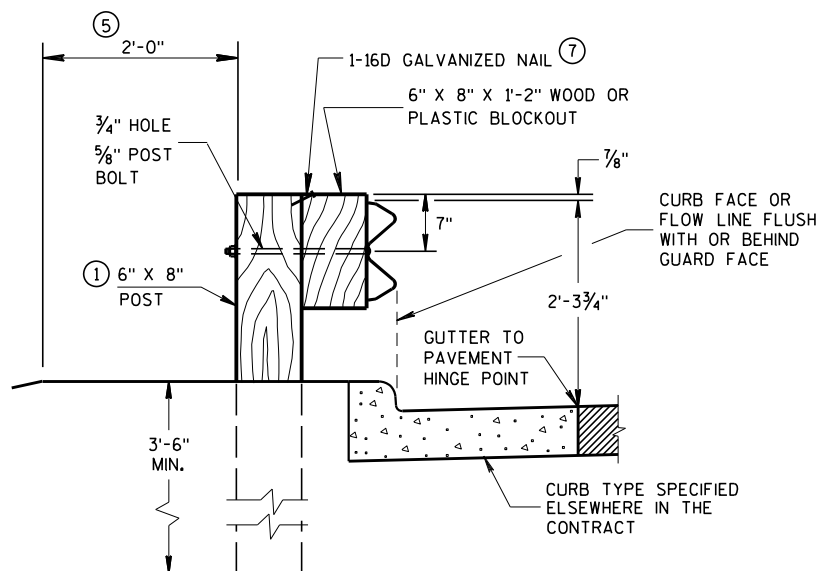

END VIEW LOCATED ALONG A CURBED ROADWAY

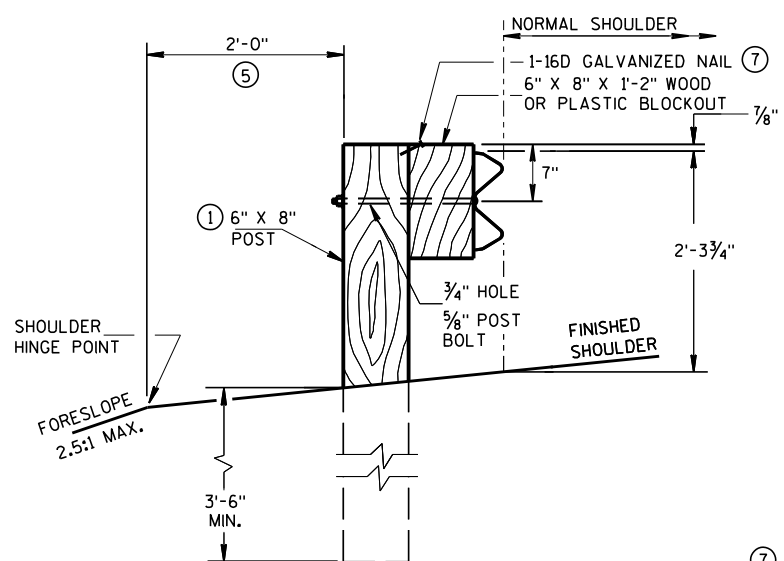

END VIEW LOCATED ALONG A ROADWAY SHOULDER STANDARD INSTALLATION

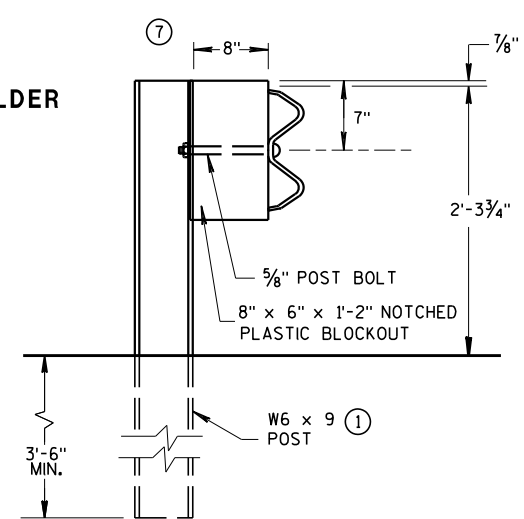

END VIEW STEEL POST & NOTCHED PLASTIC BLOCKOUT ALTERNATIVE STANDARD INSTALLATION

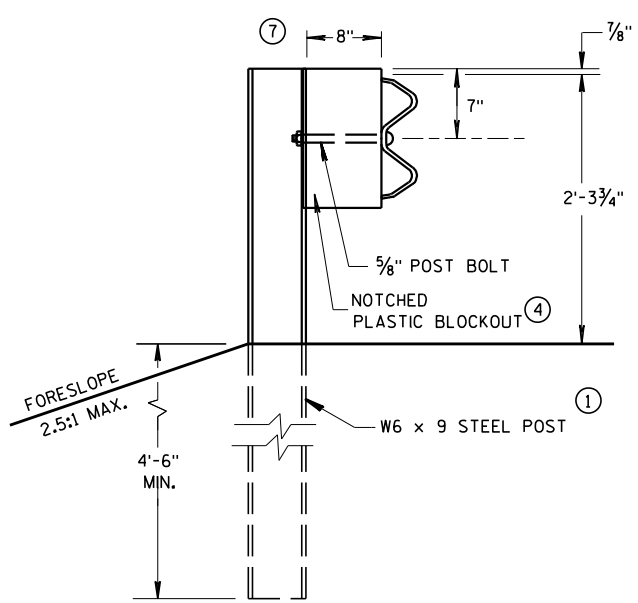

END VIEW LONGER POST AT HALF POST SPACING W BEAM (LHW)

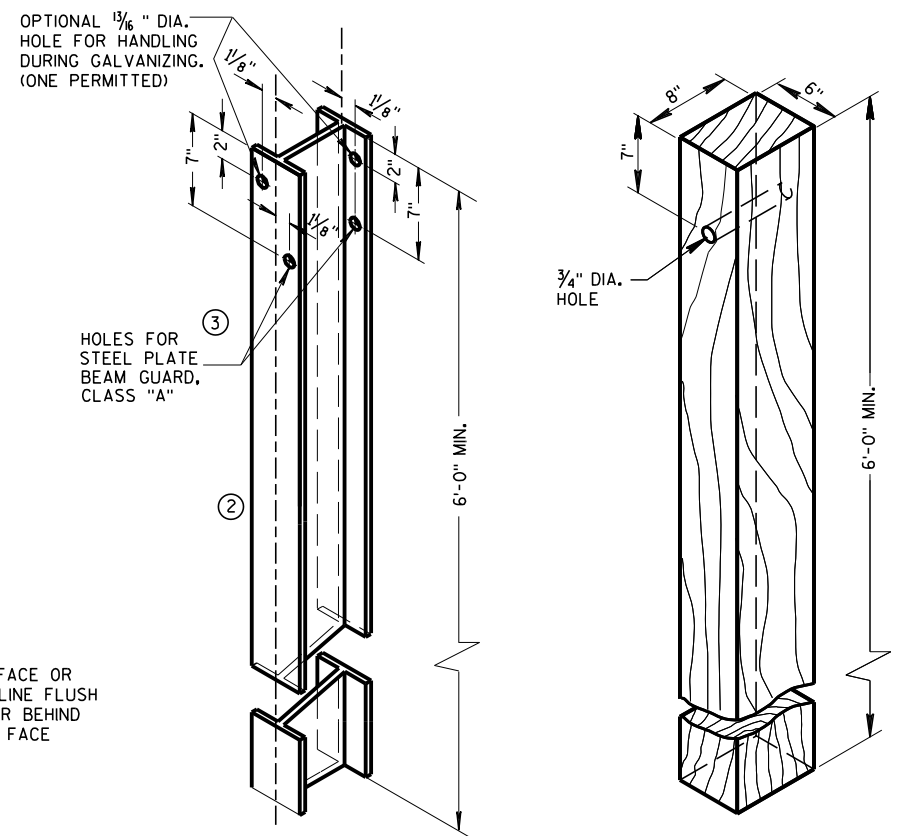

STEEL POST & HOLE PUNCHING DETAIL (W6 X 9) ①
ALL HOLES 1/8" DIAMETER EXCEPT AS NOTED

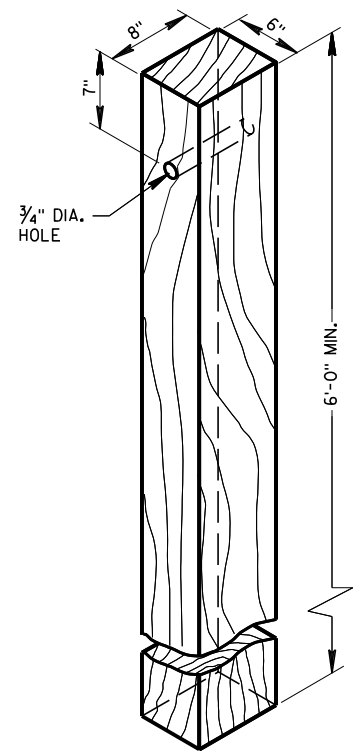

WOOD POST (6" X 8") NOMINAL

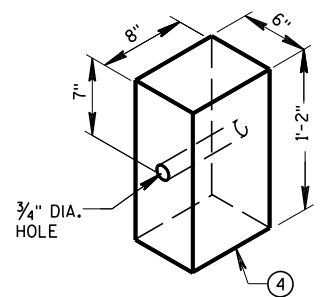

WOOD OR PLASTIC BLOCKOUT FOR WOOD POSTS

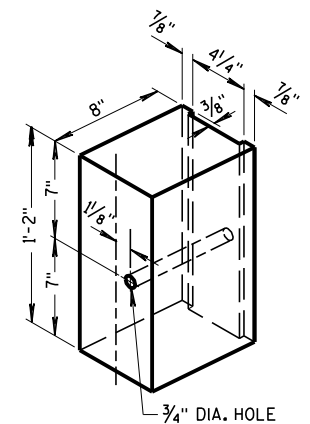

TYPICAL NOTCHED PLASTIC BLOCKOUT FOR STEEL POSTS ①

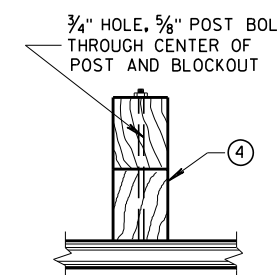

PLAN VIEW WOOD POST, BLOCKOUT & BEAM

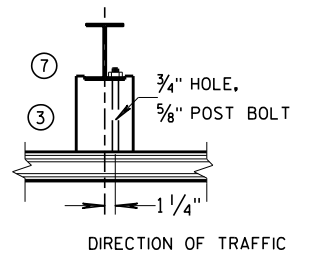

PLAN VIEW STEEL POST, NOTCHED PLASTIC BLOCKOUT & BEAM

STEEL PLATE BEAM GUARD, CLASS "A" INSTALLATION & ELEMENTS

STATE OF WISCONSIN
DEPARTMENT OF TRANSPORTATION

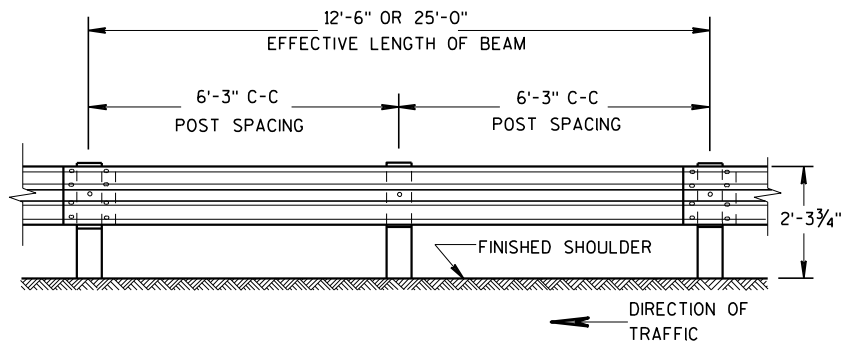

**FRONT VIEW
POST SPACING STANDARD INSTALLATION**

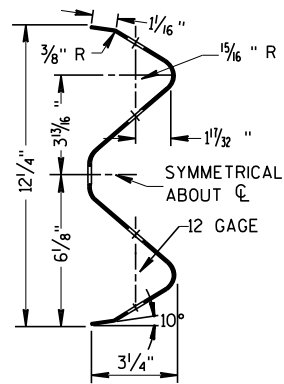

SECTION THRU W BEAM

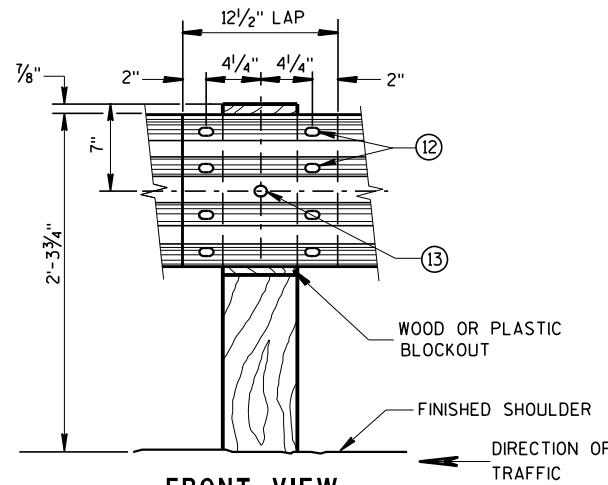

**FRONT VIEW
BEAM SPLICE AT WOOD POST
AND POST MOUNTING DETAIL**

GENERAL NOTES

- FURNISH GUARDRAIL DEFLECTORS FROM APPROVED PRODUCTS LIST.
- ⑨ DO NOT INSTALL REFLECTORS ON THE FIRST 50 FEET OF THE APPROACH END OF THE ENERGY ABSORBING TERMINA. START REFLECTORS AT POST #9 AND SPACE EVENLY EVERY 100 FEET (MAX.) TO THE END OF GUARDRAIL RUN, USING A MINIMUM OF 3 REFLECTORS.
 - ⑫ 8 - 5/8" ϕ X 2" BUTTON HEAD BOLTS WITH OVAL SHOULDERS & RECESS NUTS.
 - ⑬ 5/8" DIA. BUTTON HEAD BOLT AND RECESS NUT WITH 5/8" DIA. F844 FLAT WASHER UNDER NUT.

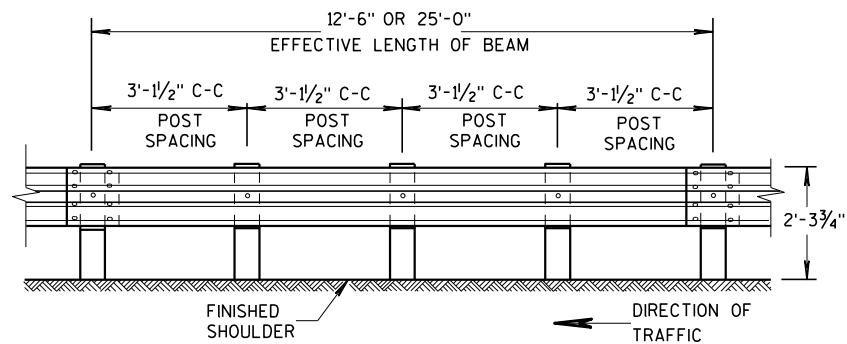

**FRONT VIEW
POST SPACING FOR LONGER POST
AT HALF POST SPACING W BEAM (LHW)**

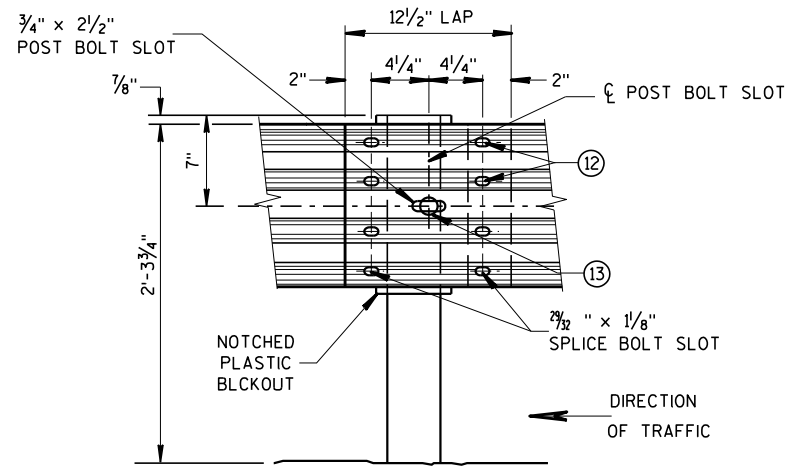

**FRONT VIEW
BEAM SPLICE AT STEEL POST
TYPICAL SPlicing DETAILS
OF STEEL PLATE BEAM GUARD**

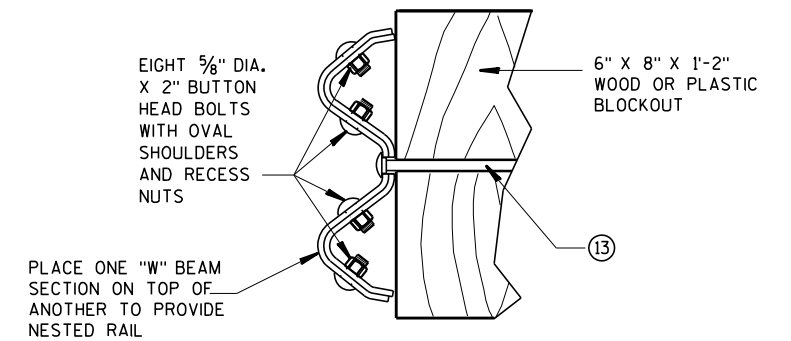

NESTED W BEAM (NW)
USE ALL OTHER STANDARD BEAM GUARD DETAILS FOR
CONSTRUCTING NESTED W BEAM (NW)

* USE DOUBLE SIDED WHITE GUARDRAIL REFLECTORS ON ROADWAYS WITH BI-DIRECTIONAL TRAFFIC (NO MEDIAN). USE SINGLE SIDED WHITE (RIGHT SIDE) AND SINGLE SIDED YELLOW (LEFT SIDE) ON ROADWAYS WITH MEDIAN SEPARATION.

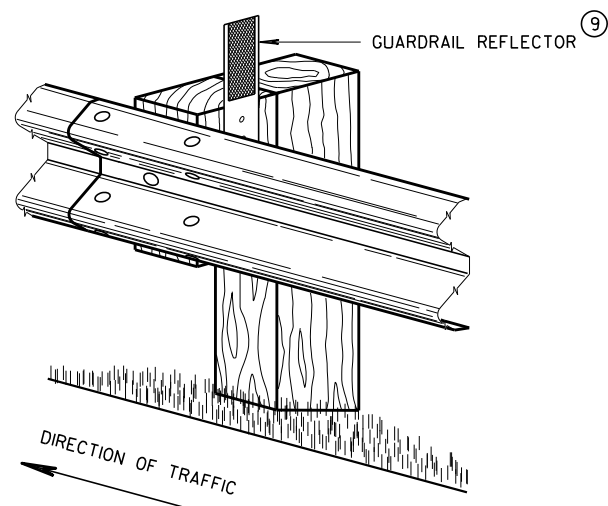

**4" X 12" GUARDRAIL REFLECTOR DETAIL
AND TYPICAL INSTALLATION ***

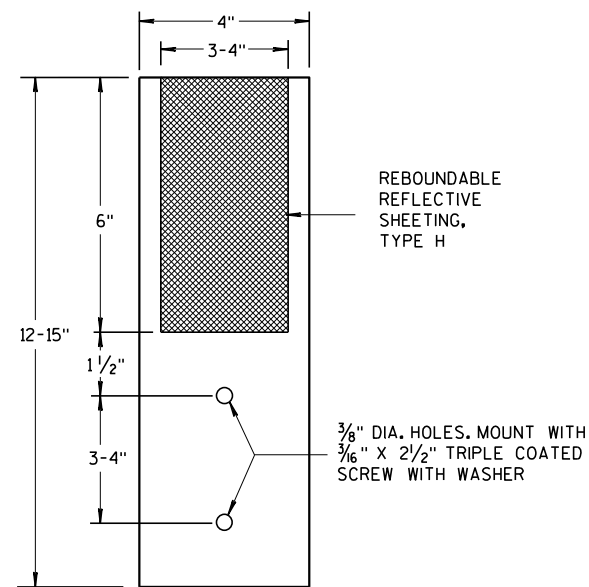

4" x 12" GUARDRAIL REFLECTOR

**STEEL PLATE BEAM GUARD,
CLASS "A",
INSTALLATION & ELEMENTS**

STATE OF WISCONSIN
DEPARTMENT OF TRANSPORTATION

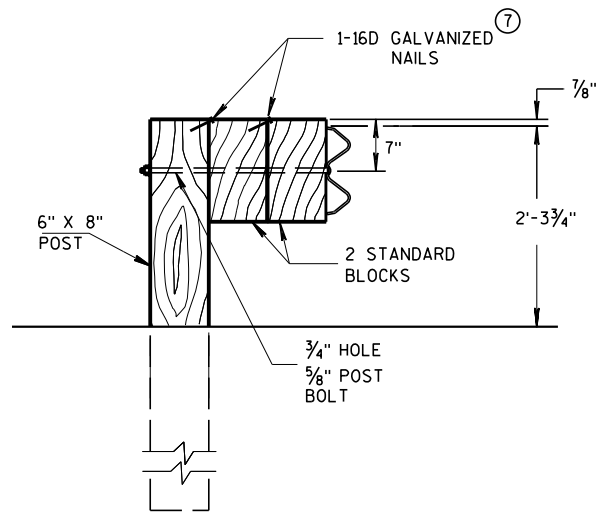

DETAIL FOR DOUBLE BLOCKS

THE NUMBER OF DOUBLE BLOCK POSTS WITHIN A BARRIER RUN IS UNLIMITED

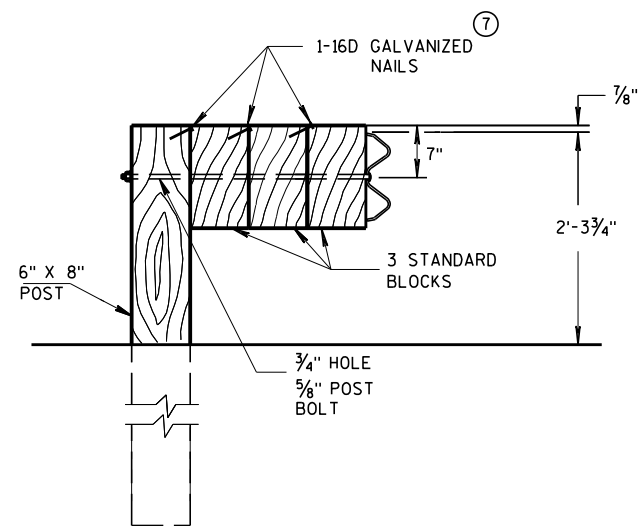

DETAIL FOR TRIPLE BLOCKS

TRIPLE BLOCK DETAIL IS LIMITED TO ONE LOCATION WITHIN A BEAM GUARD RUN.

NOTES: USE DOUBLE OR TRIPLE BLOCKS WHEN UNDERGROUND OBSTACLES PREVENT THE POST FROM BEING INSTALLED.

DO NOT USE EXTRA BLOCKOUTS IF IT CAUSES THE POST TO BE DRIVEN BEYOND SHOULDER HINGE POINT OR CAUSES A FIXED OBJECT TO BE WITHIN THE DEFLECTION DISTANCE OF THE BARRIER.

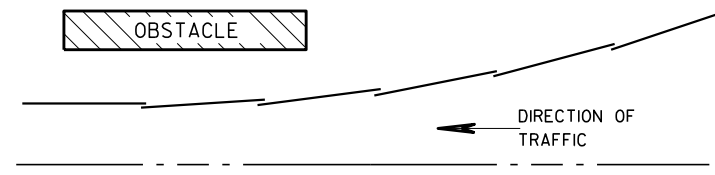

**PLAN VIEW
BEAM LAPPING DETAIL**

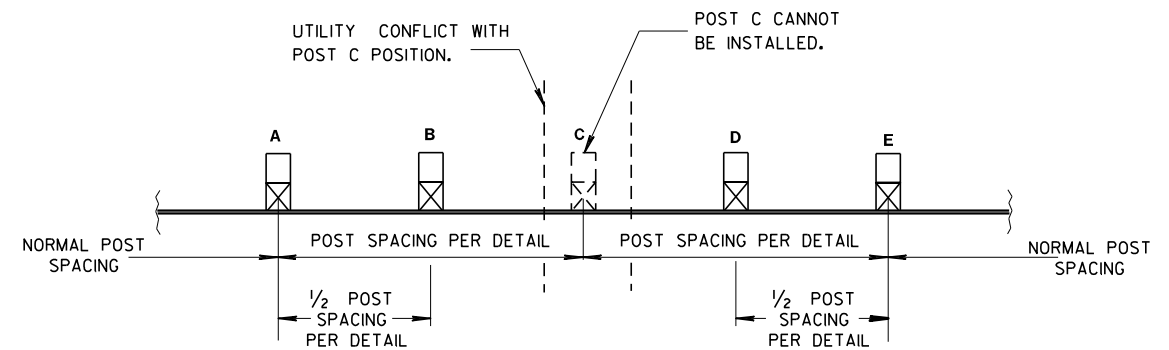

**POST DRIVING FOR CONTINUOUS
UNDERGROUND OBSTRUCTION**

6

6

S.D.D. 14 B 15-11c

S.D.D. 14 B 15-11c

STEEL PLATE BEAM GUARD, CLASS "A", INSTALLATION & ELEMENTS	
STATE OF WISCONSIN DEPARTMENT OF TRANSPORTATION	
APPROVED June 2017	/s/ Rodney Taylor
DATE	ROADWAY STANDARDS DEVELOPMENT UNIT SUPERVISOR
FHWA	

BILL OF MATERIALS

NOTE NO.	DESCRIPTION
①	WOOD BREAKAWAY TERMINAL POST: 5 1/2" X 7 1/2" X 3'-9"
②	STEEL TUBE TS 8" X 6" X 0.188", 6'-0"
④	WOOD BREAKAWAY CRT POST: 6" X 8" X 6'-0"
⑤	WOOD OFFSET BLOCKS: 6' X 8" X 1'-2"
⑥	PIPE SLEEVE: 2" X 5 1/2" STANDARD PIPE
⑦	BEARING PLATE
⑧	BCT CABLE ASSEMBLY
⑨	CABLE ANCHOR BOX
⑩	STRUT & YOKE
⑪	STEEL PLATE BEAM, END PANEL 12 GA.
⑫	STEEL PLATE BEAM: 12 GA. 13'-6 1/2"
⑬	IMPACT HEAD
⑭	0.040" ALUMINUM SHEET WITH REFLECTIVE SHEETING TYPE F PER SECTION 637 OF THE STANDARD SPECIFICATIONS

GENERAL NOTES

FOLLOW MANUFACTURE'S BOLTING RECOMMENDATIONS.

- (A) THE SLOPE IN THE AREA BOUNDED BY THE GRADELINE, THE HINGE POINT LINE (HPL), AND THE CLEAR ZONE LIMITS (CZL) SHALL BE 4:1 OR FLATTER.
- (B) AFTER FINAL ASSEMBLY, RECHECK CABLE TO BE SURE IT IS TAUT AND HAS NOT RELAXED.
- (D) THE TOP OF THE STEEL TUBE ON POSTS 1 AND 2 SHALL NOT BE MORE THAN 3" ABOVE THE FINISH GROUND ELEVATION.
- (E) THE CENTER OF THE UPPER 3 1/2" DIAMETER HOLE ON POST 3 THROUGH 8 SHALL BE 3/4" ABOVE THE FINISHED GROUND LINE.
- (F) ATTACH ALUMINUM SHEET TO E.A.T. HEAD USING 4 STAINLESS STEEL SELF-TAPPING SCREWS, ONE SCREW PER CORNER.

STEEL POSTS SHALL NOT BE ALLOWED FOR USE WITH ENERGY ABSORBING TERMINALS.
DO NOT INSTALL REFLECTORS ON THE FIRST 50 FEET OF THE APPROACH END OF THE ENERGY ABSORBING TERMINAL.

*DO NOT ATTACH BLOCKOUTS TO POSTS 1 AND 2.

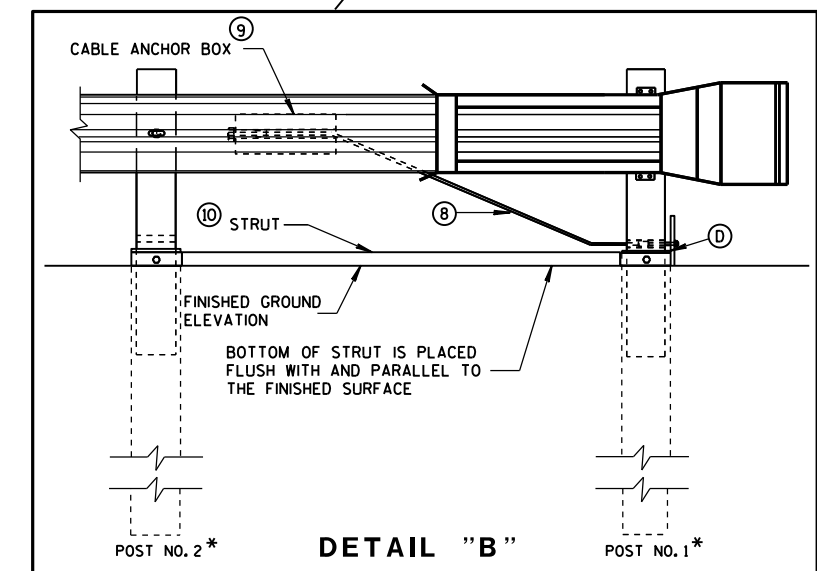
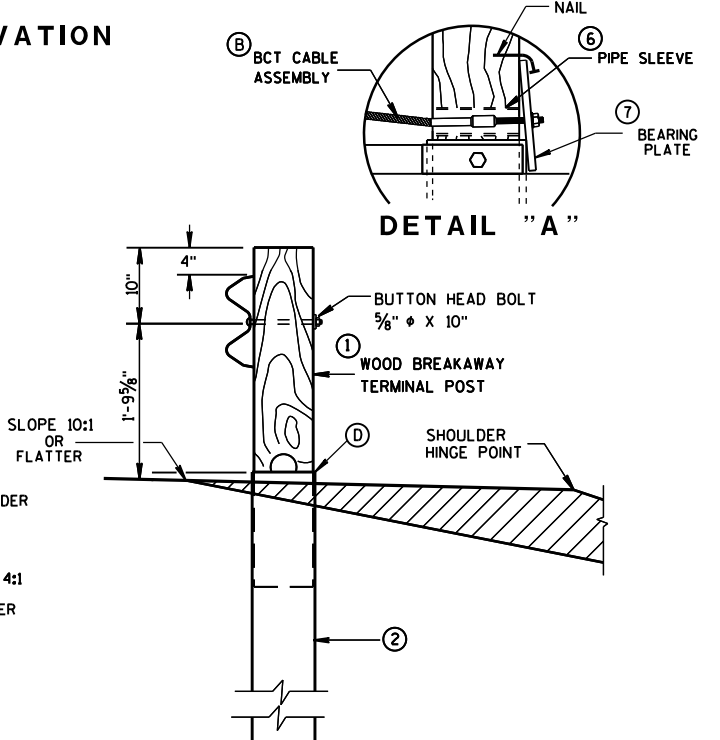
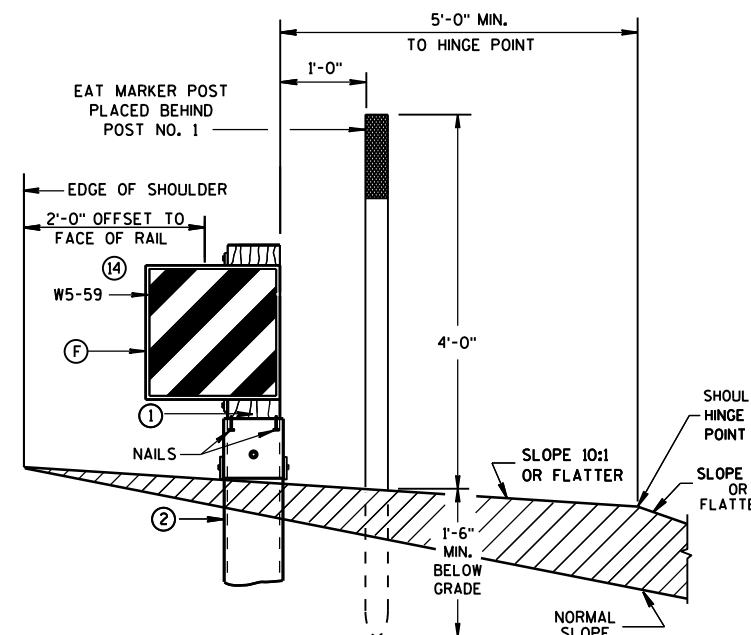
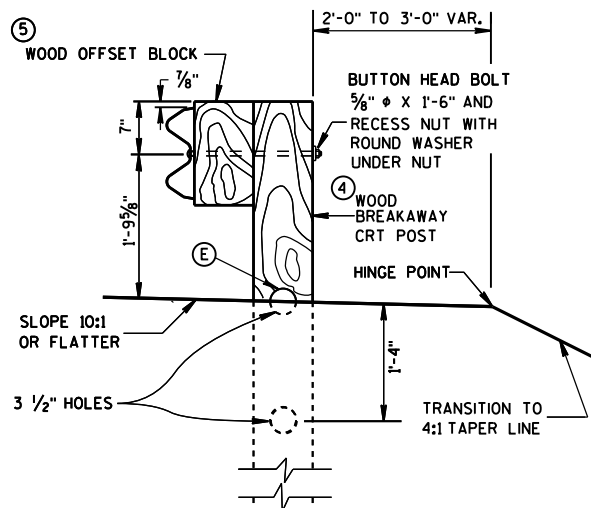
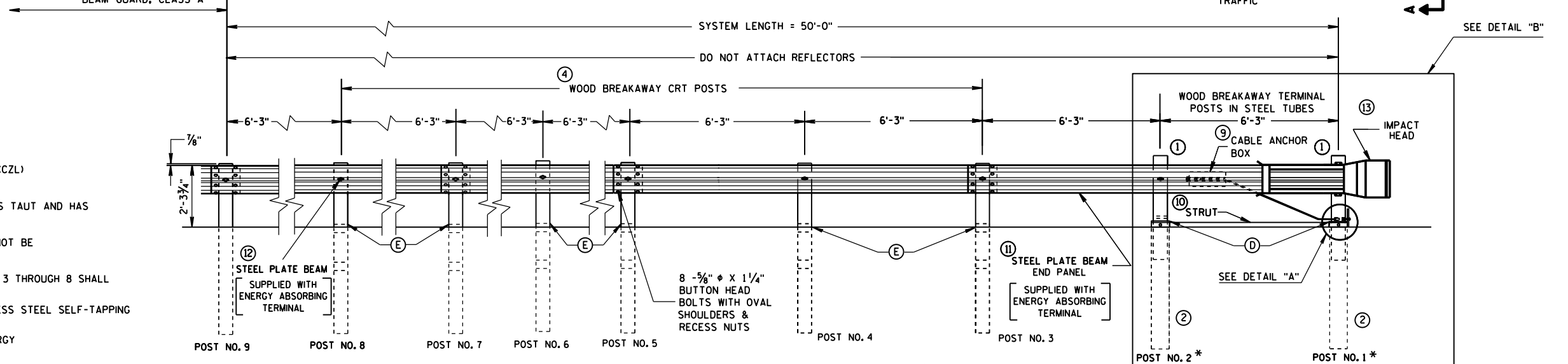
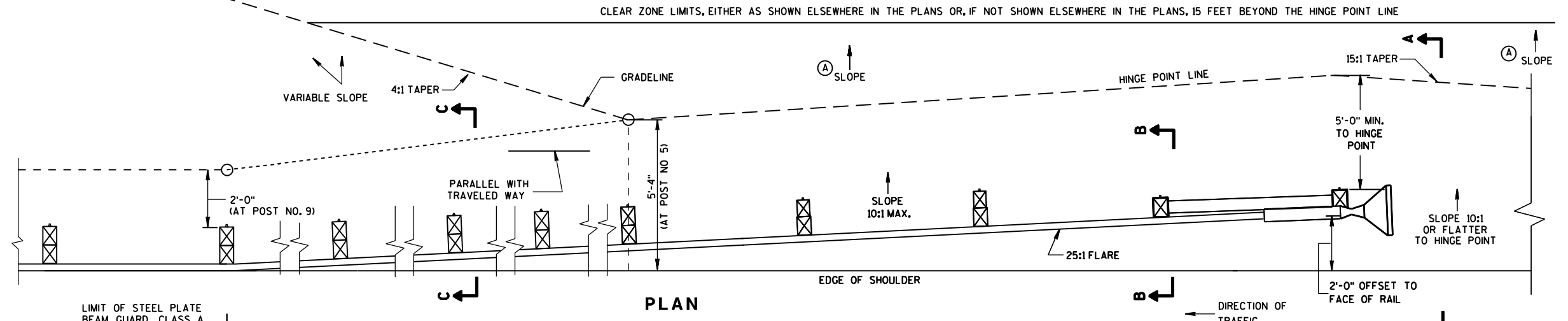

STEEL PLATE BEAM GUARD ENERGY ABSORBING TERMINAL
STATE OF WISCONSIN DEPARTMENT OF TRANSPORTATION

6

6

S.D.D. 14 B 24-9a

S.D.D. 14 B 24-9a

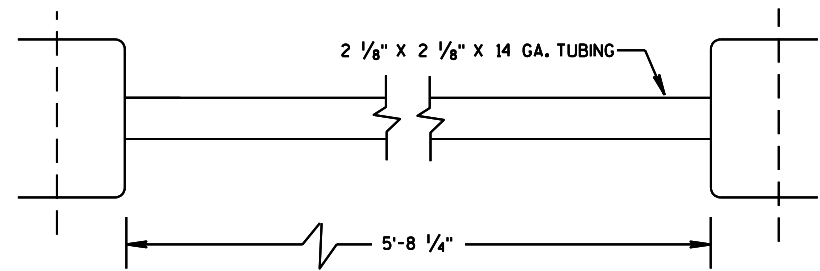

⑩ STRUT DETAIL

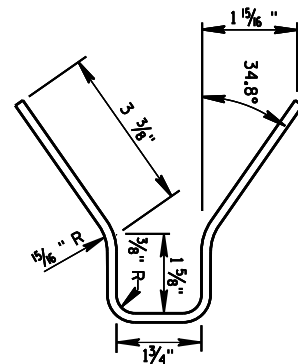
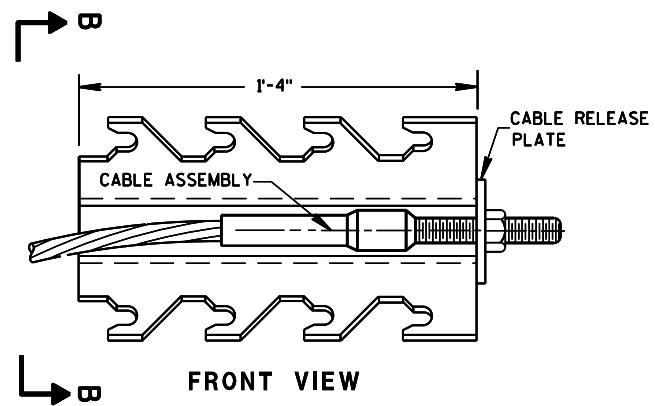

⑨ CABLE ANCHOR BOX

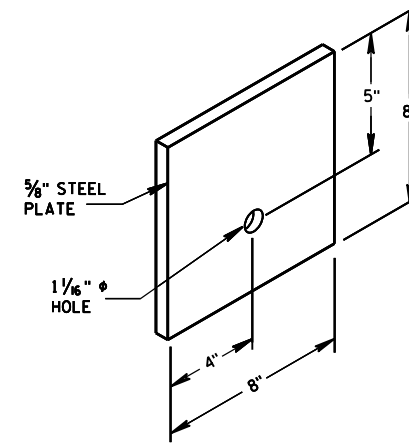

⑦ STEEL BEARING PLATE

6

6

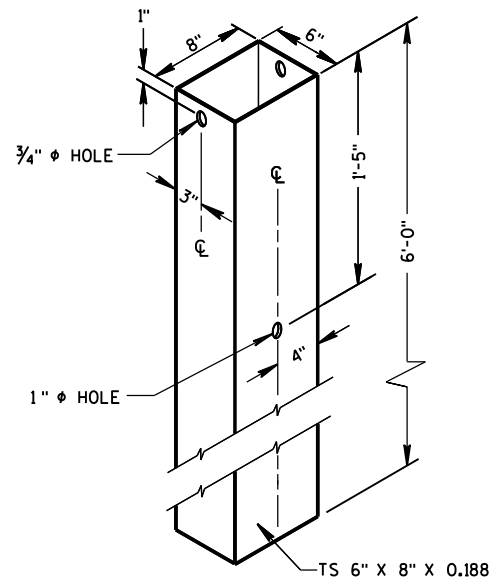

② 72" STEEL TUBE
(POSTS NO. 1-2)

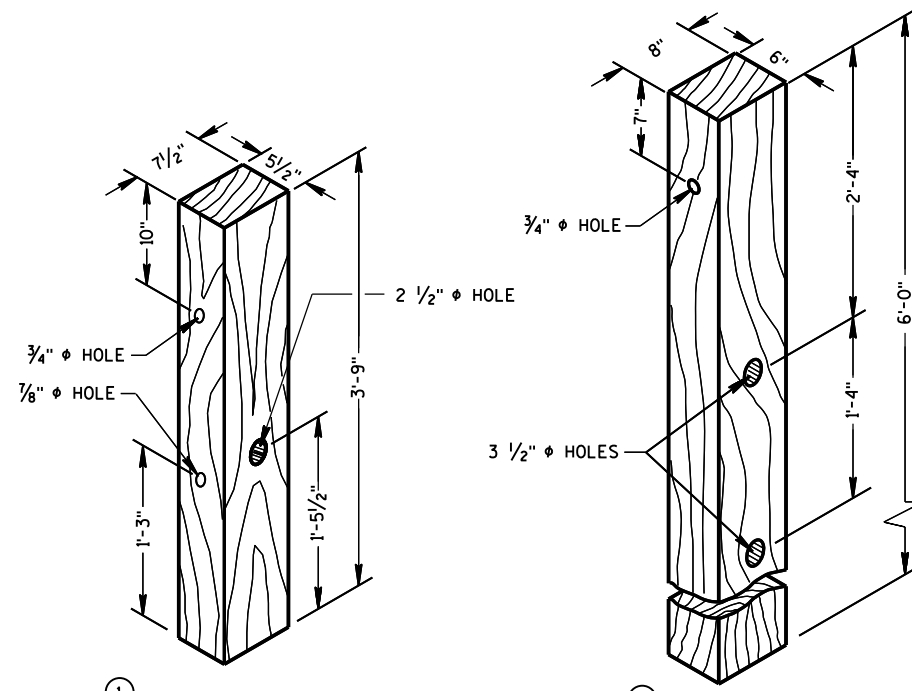

① TERMINAL POST

④ CRT POST
(POSTS NO'S 5-8)

WOOD BREAKAWAY POSTS

GENERAL NOTES

WHEN ROCK IS ENCOUNTERED DURING EXCAVATION, A 12 INCH DIA. POST HOLE EXTENDING 20 INCHES DEEP INTO THE ROCK MAY BE USED IF APPROVED BY THE ENGINEER. GRANULAR MATERIAL SHALL BE PLACED IN THE BOTTOM OF THE HOLE APPROXIMATELY 2 1/2" INCHES DEEP TO PROVIDE DRAINAGE. THE SOIL TUBES SHALL BE FIELD CUT TO LENGTH, PLACED IN THE HOLE AND BACKFILLED WITH ADEQUATELY COMPACTED MATERIAL EXCAVATED FROM THE HOLE.

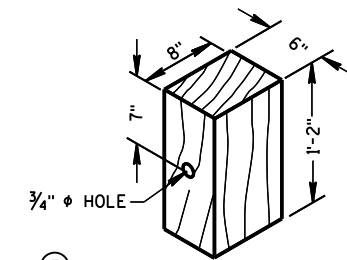

⑤ WOOD OFFSET BLOCK
REQ'D. AT ALL POSTS EXCEPT POST NO'S 1 & 2

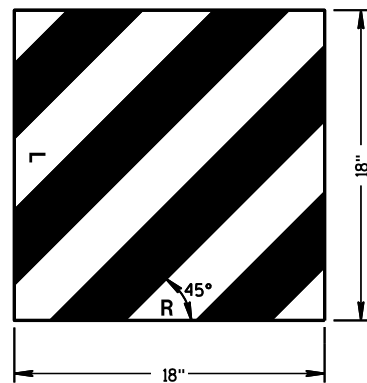

⑭ REFLECTIVE SHEETING DETAILS

TYPE H
YELLOW REFLECTIVE
SHEETING 3" X 9".
SEE STANDARD
SPECIFICATION 637.

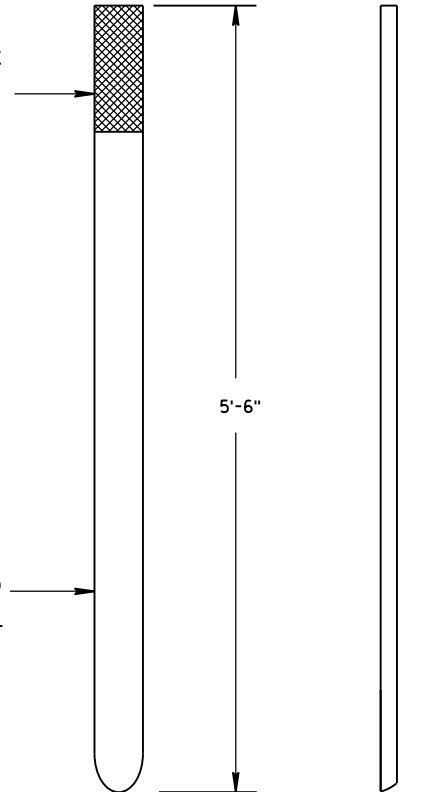

FRONT VIEW SIDE VIEW

E.A.T. MARKER POST

E.A.T. MARKER
POST (YELLOW)
SEE APPROVED
PRODUCTS LIST

STEEL PLATE BEAM GUARD
ENERGY ABSORBING TERMINAL

STATE OF WISCONSIN
DEPARTMENT OF TRANSPORTATION

APPROVED
June 2017 /S/ Rodney Taylor
DATE ROADWAY STANDARDS DEVELOPMENT
FHWA UNIT SUPERVISOR

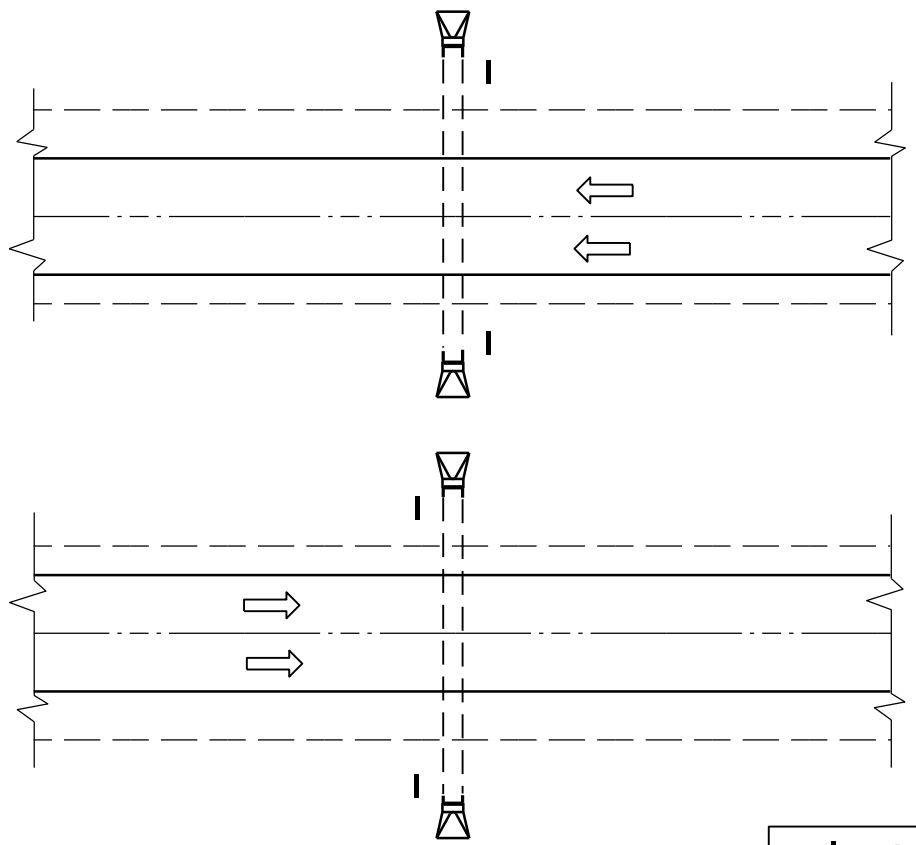

PLAN VIEW
DIVIDED HIGHWAY

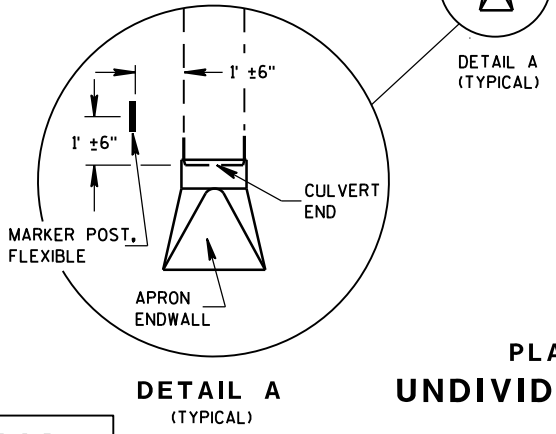

PLAN VIEW
UNDIVIDED HIGHWAY

MARKER POST, FLEXIBLE
 DIRECTION OF TRAFFIC FLOW

FLEXIBLE MARKER POST LOCATION

GENERAL NOTES

DETAILS OF CONSTRUCTION, MATERIALS AND WORKMANSHIP NOT SHOWN ON THIS DRAWING SHALL CONFORM TO THE PERTINENT REQUIREMENTS OF THE STANDARD SPECIFICATIONS AND THE APPLICABLE SPECIAL PROVISIONS.

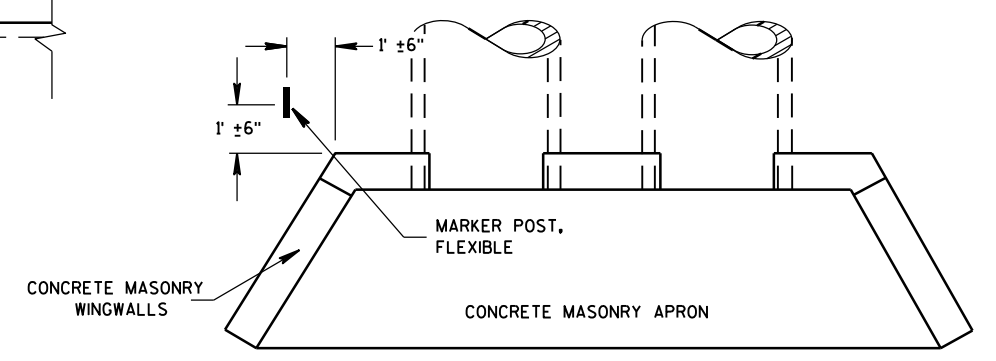

PLAN VIEW
CONCRETE MASONRY ENDWALLS FOR
CULVERT PIPE AND PIPE ARCH

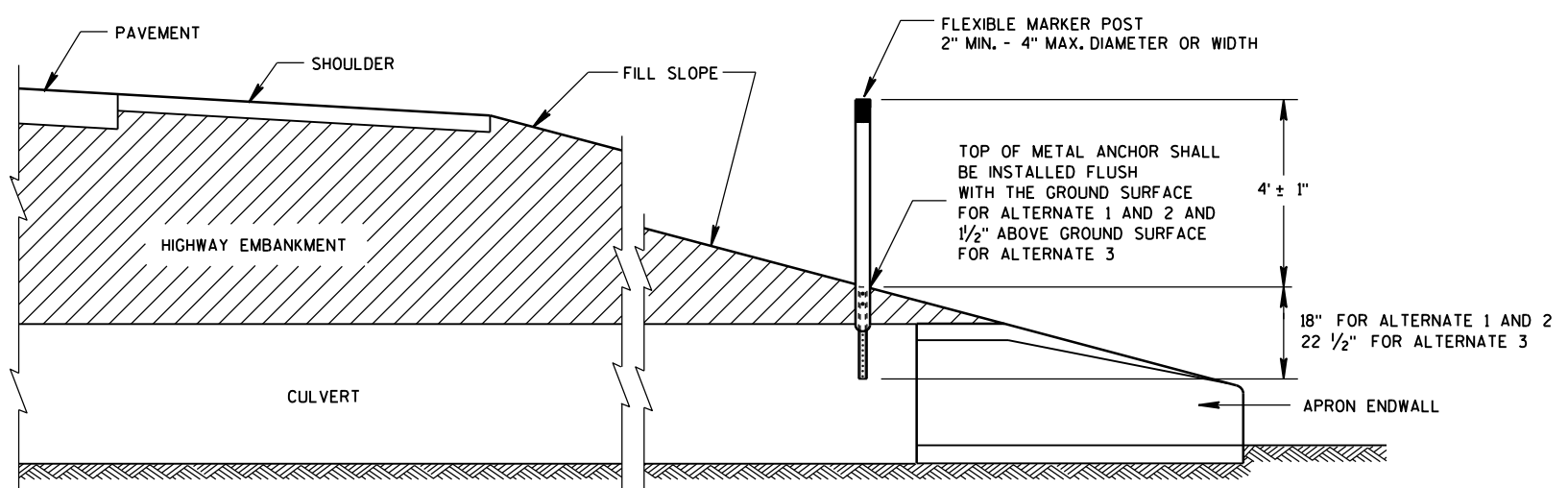

CROSS SECTION
FLEXIBLE MARKER POST

**FLEXIBLE MARKER POST
FOR CULVERT END**

 STATE OF WISCONSIN
 DEPARTMENT OF TRANSPORTATION

6

6

S.D.D. 15 A 3-2a

S.D.D. 15 A 3-2a

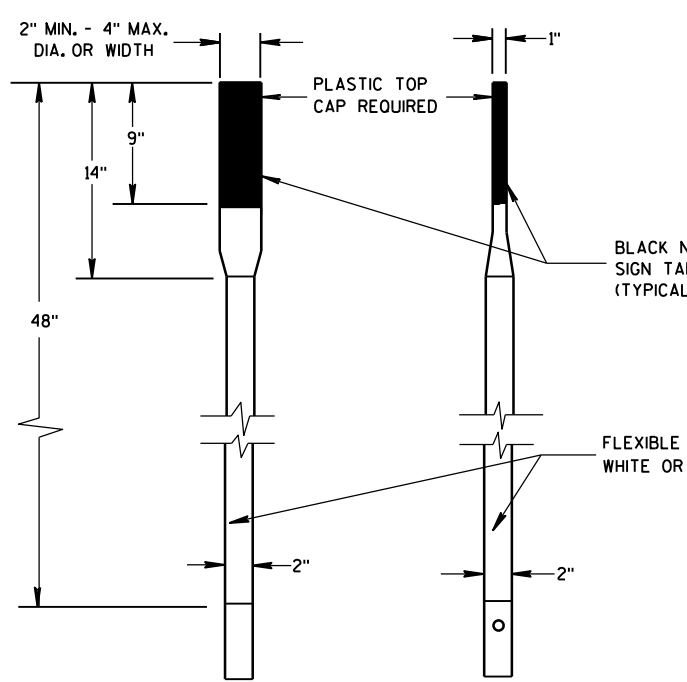

FRONT VIEW SIDE VIEW
ALTERNATE 1

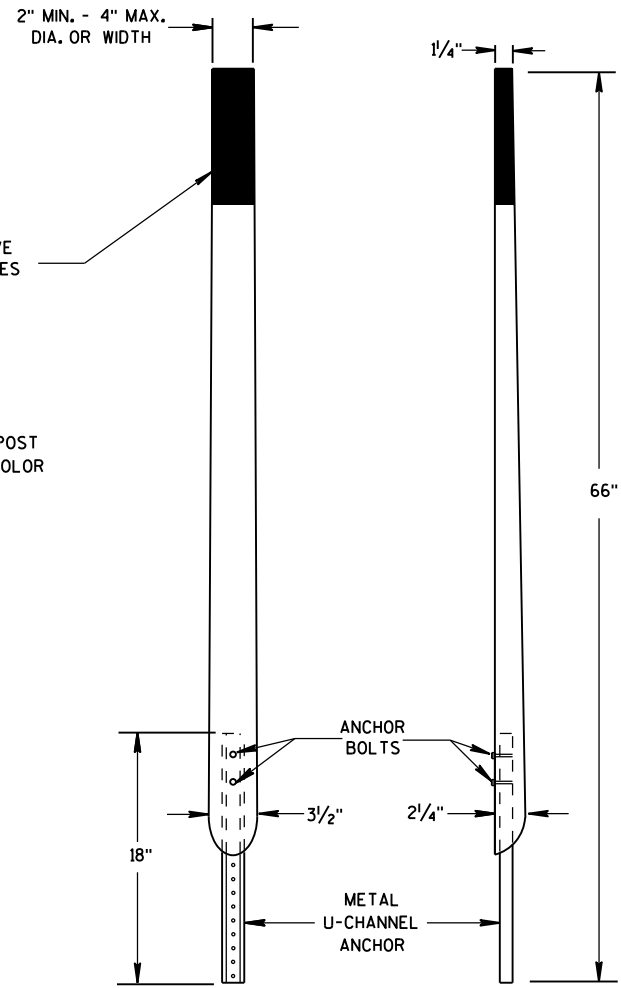

FRONT VIEW SIDE VIEW
ALTERNATE 2

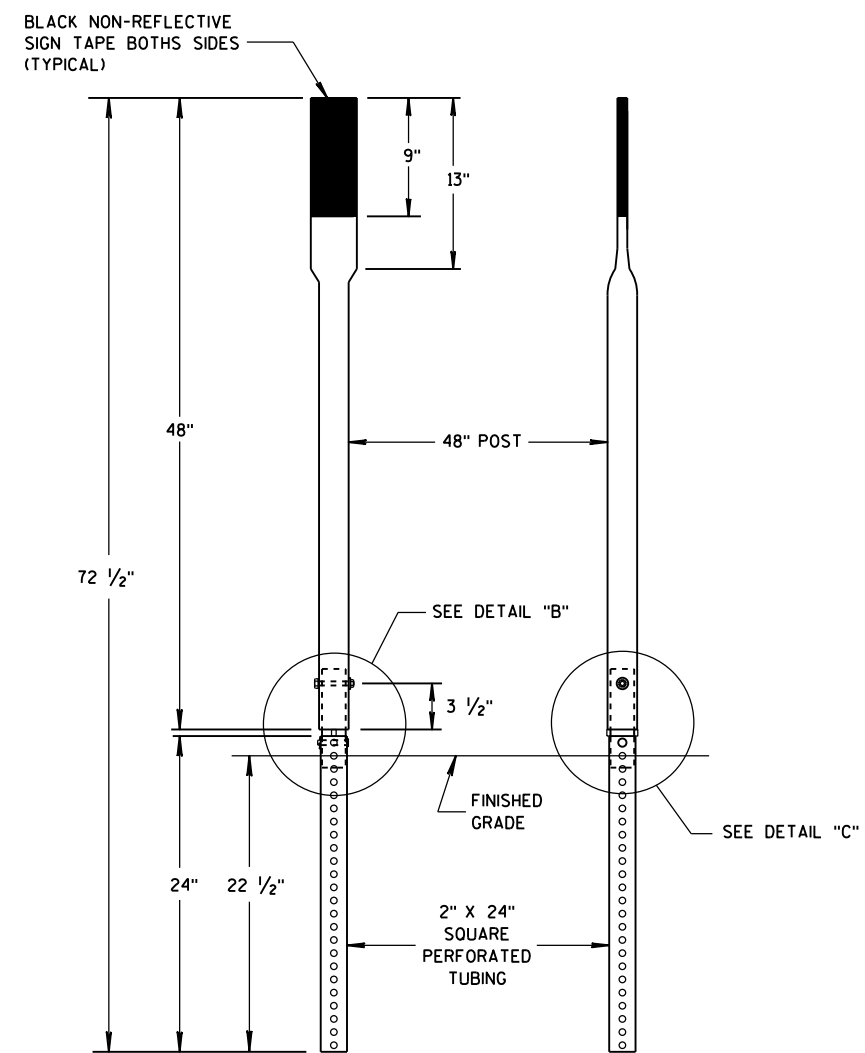

FRONT VIEW SIDE VIEW
ALTERNATE 3

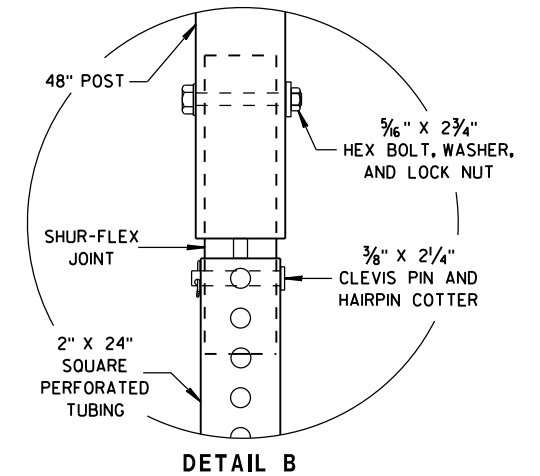

DETAIL B

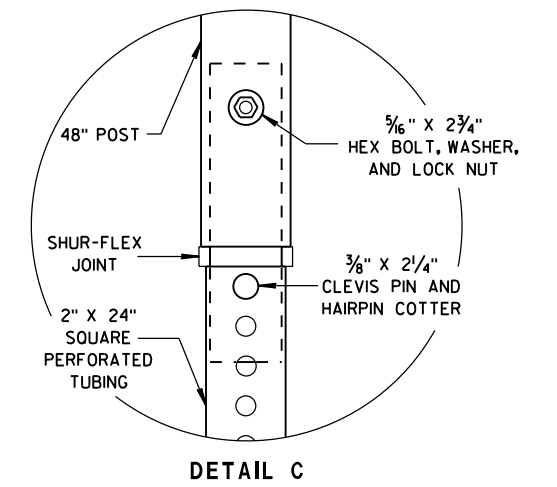

DETAIL C

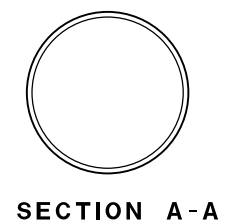

SECTION A-A

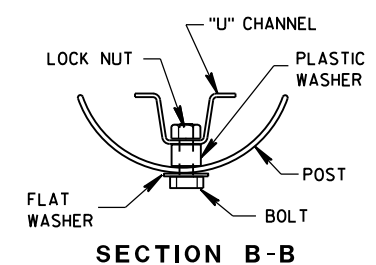

SECTION B-B

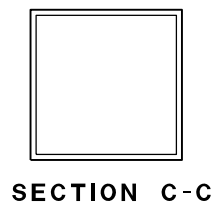

SECTION C-C

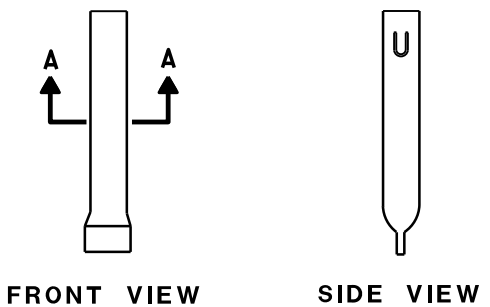

FRONT VIEW SIDE VIEW
ALTERNATE 1

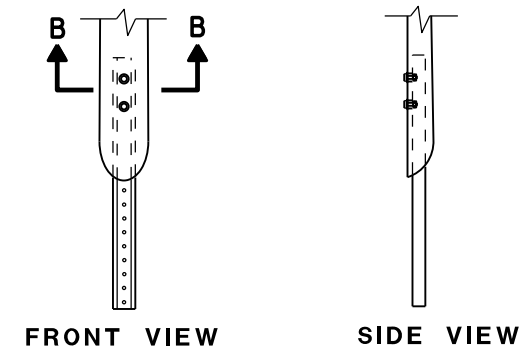

FRONT VIEW SIDE VIEW
ALTERNATE 2

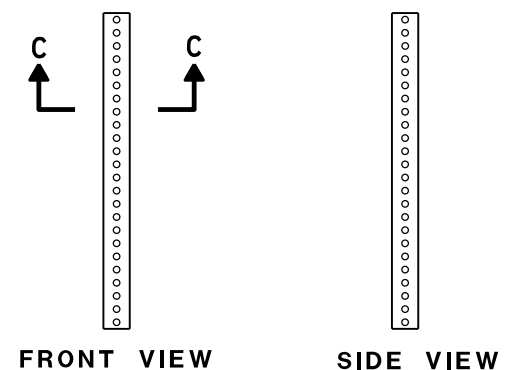

FRONT VIEW SIDE VIEW
ALTERNATE 3

FLEXIBLE MARKER POST ANCHORS

FLEXIBLE MARKER POST FOR CULVERT END	
STATE OF WISCONSIN DEPARTMENT OF TRANSPORTATION	
APPROVED 10/1/2012 DATE	/S/ Travis Feltes STATE TRAFFIC ENGINEER OF DESIGN
FHWA	

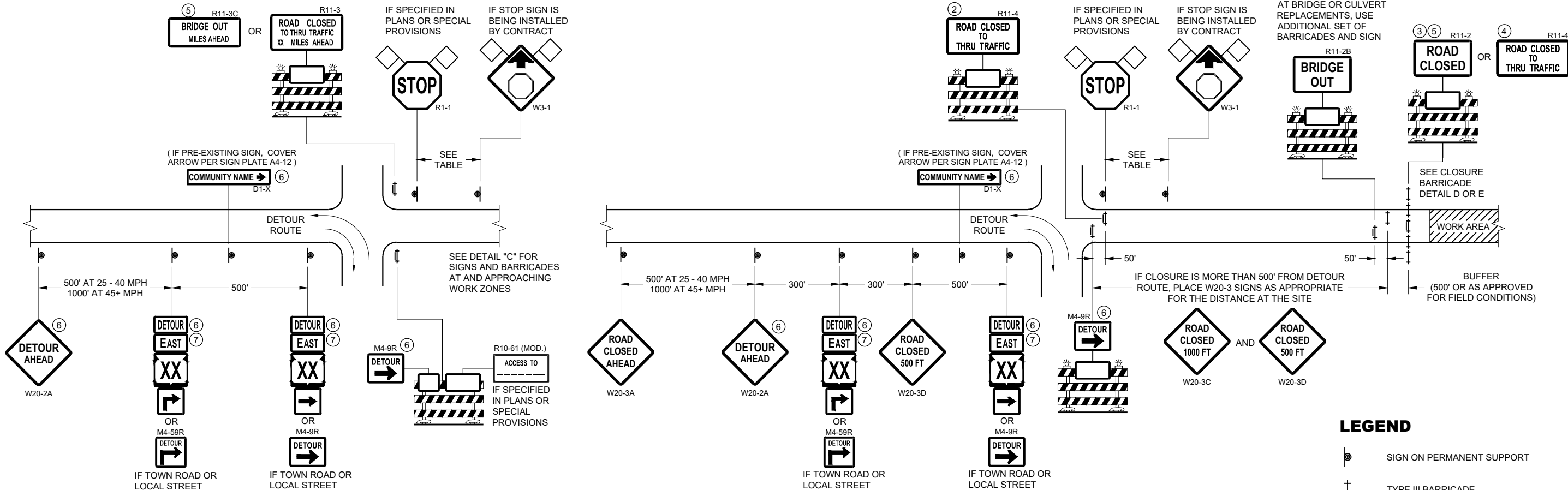

**DETAIL A
MAINLINE CLOSURE WITH POSTED DETOUR**

WORK ZONE GREATER THAN OR EQUAL TO 1/2 MILE FROM
DETOUR ROUTE (1000 FEET IF URBAN)

**DETAIL B
MAINLINE CLOSURE WITH POSTED DETOUR**

WORK ZONE LESS THAN 1/2 MILE FROM
DETOUR ROUTE (1000 FEET IF URBAN)

LEGEND

- SIGN ON PERMANENT SUPPORT
- TYPE III BARRICADE
- TYPE III BARRICADE WITH ATTACHED SIGN
- TYPE "A" WARNING LIGHT (FLASHING)
- WORK AREA
- FLAGS, 16" X 16" MIN. (ORANGE)

SPEED LIMIT (MPH)	"STOP AHEAD" ADVANCE WARNING DISTANCE (FT)
25	200
30	200
35	350
40	350
45	500
50	550
55	750

- M4 - 8
- M3 - X
- OR OR M1 - 4 M1 - 6 M1 - 5A
- OR M05 - 1 M06 - 1

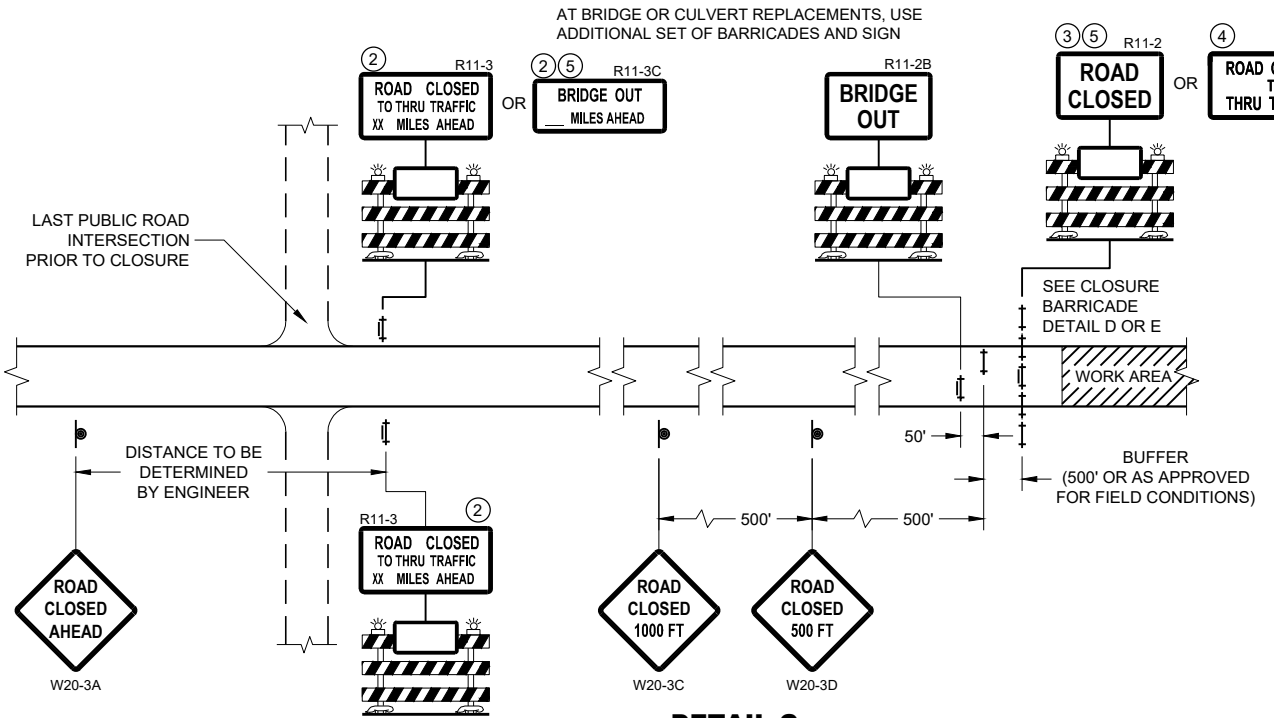

**DETAIL C
MAINLINE CLOSURE, NO POSTED DETOUR**

SEE SDD 15C2-SHEET "b"
FOR GENERAL NOTES
AND FOOTNOTES ① THROUGH ⑦

**BARRICADES AND SIGNS
FOR MAINLINE CLOSURES**

STATE OF WISCONSIN
DEPARTMENT OF TRANSPORTATION

APPROVED
February 2020 /S/ Andrew Heidtke
DATE WORK ZONE ENGINEER

LEGEND

- SIGN ON PERMANENT SUPPORT
- WORK AREA
- M4 - 8
- M3 - X
- M1 - 4
- M1 - 6
- M1 - 5A
- M05 - 1
- M06 - 1
- M06 - 1

GENERAL NOTES

THE EXACT NUMBER, LOCATION AND SPACING OF ALL SIGNS SHALL BE ADJUSTED TO FIT FIELD CONDITIONS AS APPROVED BY THE ENGINEER.

IF THERE ARE EXISTING ROUTE MARKER ASSEMBLIES THAT WILL REMAIN IN PLACE, ADJUST THE LOCATION OF THE DETOUR ROUTE SIGNS TO CORRESPOND WITH THE EXISTING ASSEMBLIES. SEE SPECIFIC PROJECT DETOUR SIGNING DETAIL SHEETS. MODIFY EXISTING SIGNS WHERE POSSIBLE.

THE SPACING BETWEEN TRAFFIC CONTROL AND DETOUR SIGNS SHOULD BE ADJUSTED TO NOT CONFLICT WITH AND TO PROVIDE A DESIRABLE MINIMUM OF 200 FEET CLEARANCE TO EXISTING SIGNS THAT WILL REMAIN IN PLACE.

ANY SIGNS TEMPORARY OR EXISTING, WHICH CONFLICT WITH TRAFFIC CONTROL "IN USE" SHALL BE REMOVED OR COVERED AS NEEDED AND AS APPROVED BY THE ENGINEER.

SIGNS THAT WILL BE IN PLACE LESS THAN 7 CONTINUOUS DAYS AND NIGHTS MAY BE MOUNTED ON PORTABLE SUPPORTS.

"MO" SIGNS ARE THE SAME AS "M" SIGNS EXCEPT THE BACKGROUND IS ORANGE.

SIGN SIZES SHALL BE AS FOLLOWS:

- M3-X SHALL BE 24" X 12" (36" X 18" IF NEEDED TO MATCH EXISTING SIGNS)
- M4-8 SHALL BE 24" X 12" (36" X 18" IF NEEDED TO MATCH EXISTING SIGNS)
- M1-4, M1-5A AND M1-6 SHALL BE 24" X 24" (36" X 36" IF NEEDED TO MATCH EXISTING SIGNS)
- M05-1 AND M06-1 SHALL BE 21" X 21" (30" X 30" IF NEEDED TO MATCH EXISTING SIGNS)
- M4-9 AND M4-9R SHALL BE 30" X 24"
- M4-8a SHALL BE 24" X 18"
- G20-51 SHALL BE 60" X 24"
- W20-2A SHALL BE 48" X 48"
- D1-X SHALL BE AS SHOWN ON SPECIFIC PROJECT SIGNING DETAIL SHEETS.

- * OPTIONAL SIGNS. SEE SPECIFIC PROJECT DETOUR SIGNING DETAIL SHEETS.
- ** FOR A TOWN ROAD OR LOCAL STREET DETOURED ONTO A STATE TRUNK HIGHWAY, PLACE A ROAD NAME PLAQUE ABOVE THE M4-9 SIGN AS SPECIFIED IN THE CONTRACT.

THIS DRAWING PROVIDES GENERAL GUIDANCE ON TYPICAL DETOUR SIGN LAYOUT AND SPACING. SEE PROJECT DETOUR SIGNING SHEETS FOR SPECIFIC DETAILS FOR EACH PROJECT.

MATCH POINT

DETAIL F DETOUR SIGNING

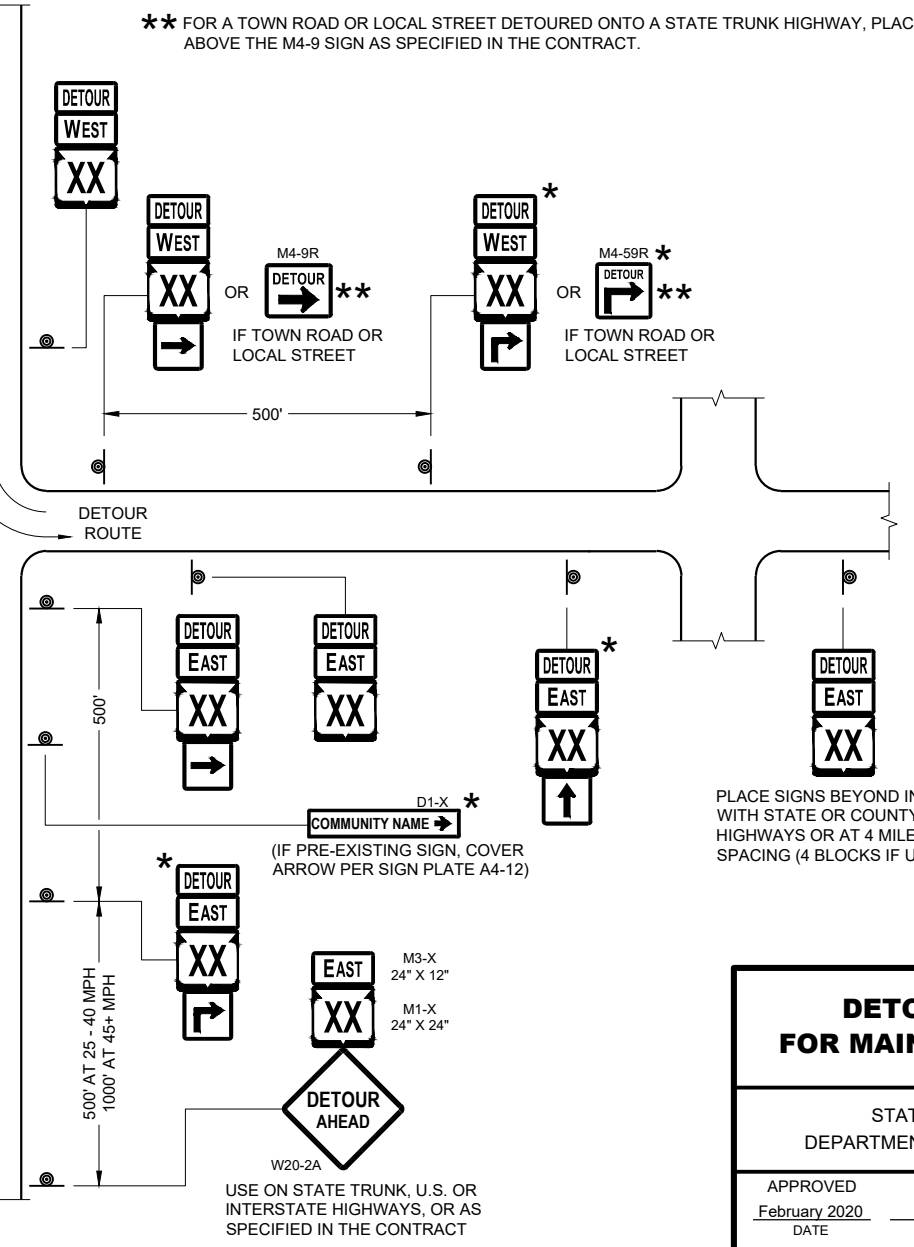
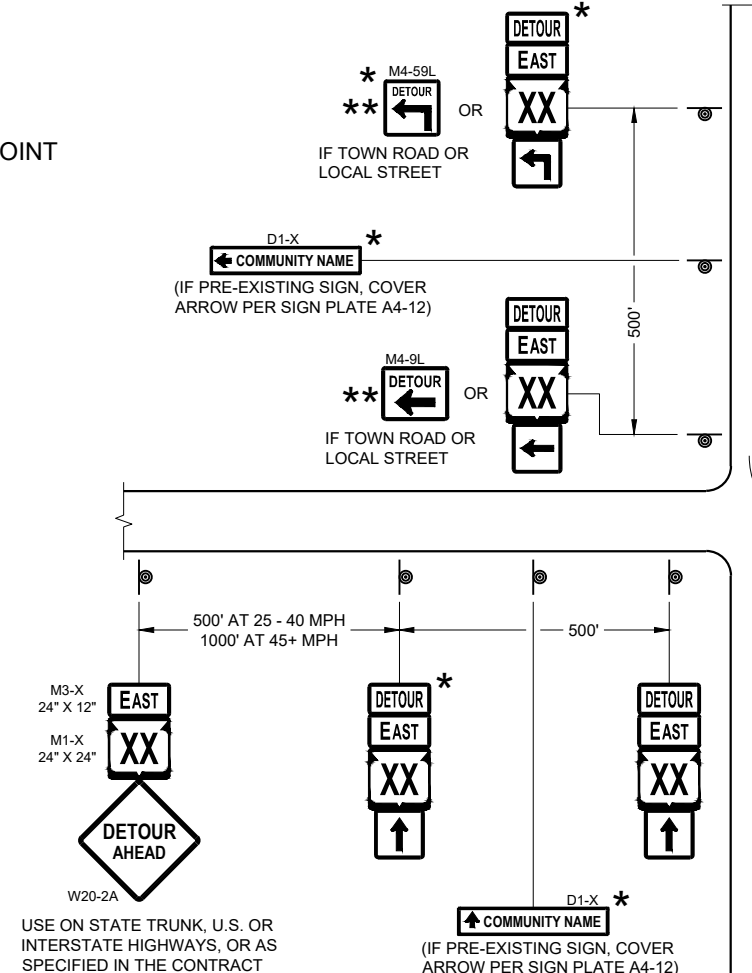
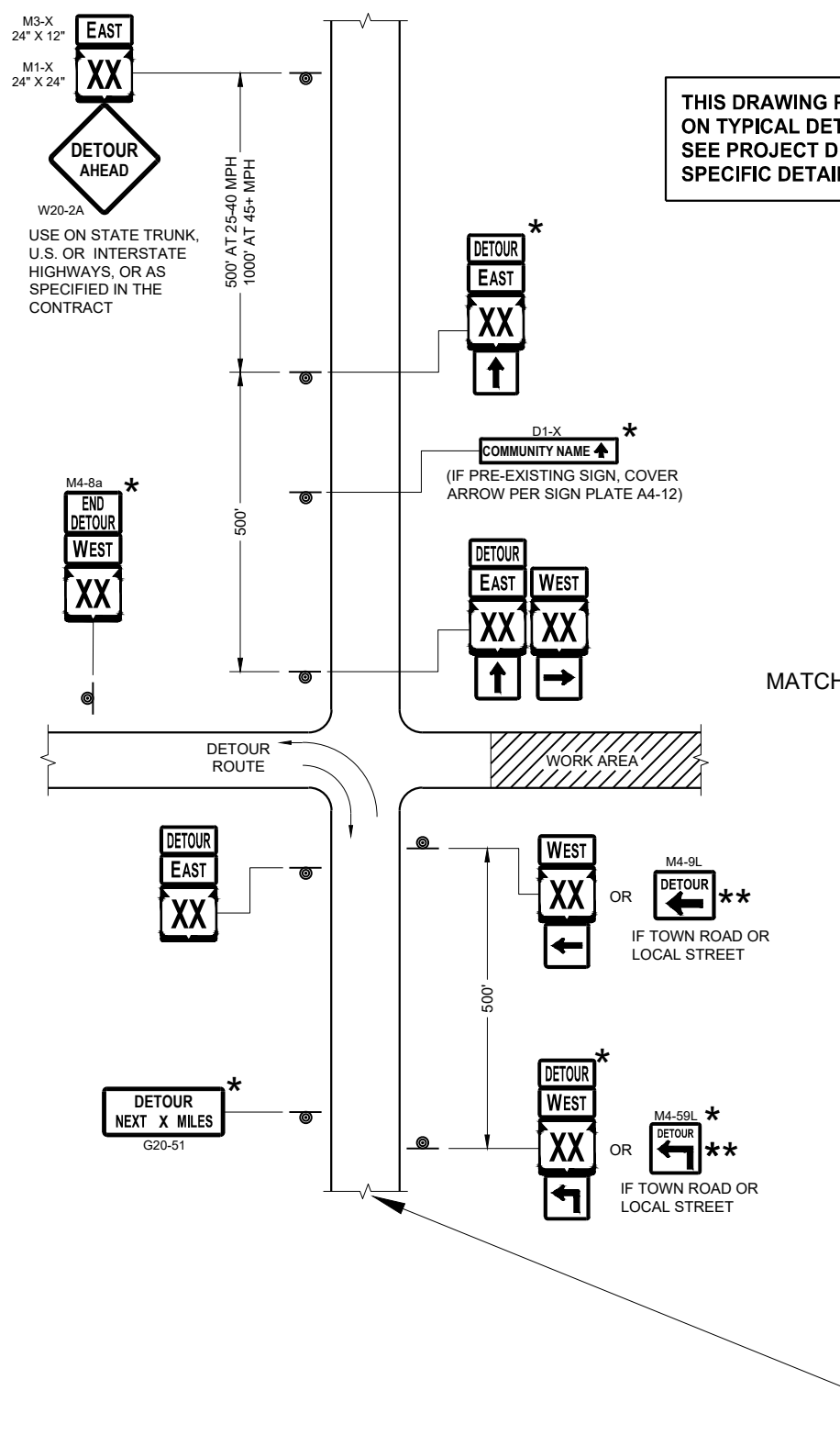

DETOUR SIGNING FOR MAINLINE CLOSURES	
STATE OF WISCONSIN DEPARTMENT OF TRANSPORTATION	
APPROVED February 2020 DATE	/S/ Andrew Heidtke WORK ZONE ENGINEER
FHWA	

SEE SPECIFIC PROJECT DETOUR SIGNING DETAIL SHEETS AND DETAIL A OR B ON SDD SHEET 15C02 - SHEET "a"

PLACE SIGNS BEYOND INTERSECTIONS WITH STATE OR COUNTY TRUNK HIGHWAYS OR AT 4 MILE MAXIMUM SPACING (4 BLOCKS IF URBAN AREA)

GENERAL NOTES

THE EXACT NUMBER, LOCATION, AND SPACING OF ALL SIGNS AND DEVICES SHALL BE ADJUSTED TO FIT FIELD CONDITIONS.

THE SPACING BETWEEN TRAFFIC CONTROL SIGNS SHOULD BE ADJUSTED TO NOT CONFLICT WITH AND SHOULD PROVIDE A MINIMUM OF 200 FEET (500 FEET DESIRABLE) CLEARANCE TO EXISTING SIGNS THAT WILL REMAIN IN PLACE.



ALL SIGNS ARE 48" X 48" UNLESS OTHERWISE NOTED.

SIGNS THAT WILL BE IN PLACE LESS THAN SEVEN CONTINUOUS DAYS AND NIGHTS MAY BE MOUNTED ON PORTABLE SUPPORTS.

IF A "STOP" SIGN MUST BE REMOVED FOR A WORK OPERATION, A TEMPORARY "STOP" SIGN SHALL BE PLACED PRIOR TO THE SIGN REMOVAL, OR A FLAGGER SHALL BE PROVIDED UNTIL THE SIGN IS REESTABLISHED.

- * OMIT G20-1 SIGNS IF LENGTH OF WORK AREA IS 2 MILES OR LESS
- ** PLACE AN ADDITIONAL W20-1A "ROAD WORK AHEAD" SIGN IF WORK AREA WITHIN THE PROJECT IS SEPARATED BY MORE THAN 2 MILES FROM PREVIOUS WORK AREA.

LEGEND

-  SIGN ON PERMANENT SUPPORT
-  DIRECTION OF TRAFFIC
-  WORK AREA

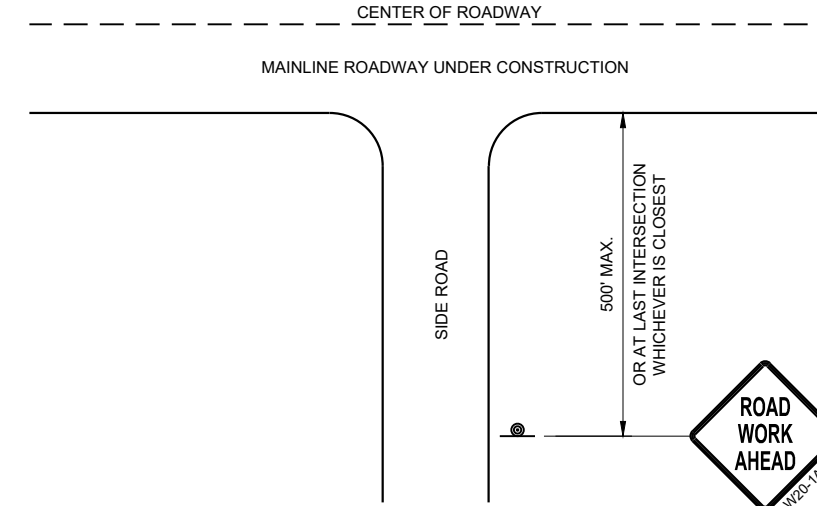

TYPICAL SIDE ROAD APPROACH WARNING SIGN DETAIL

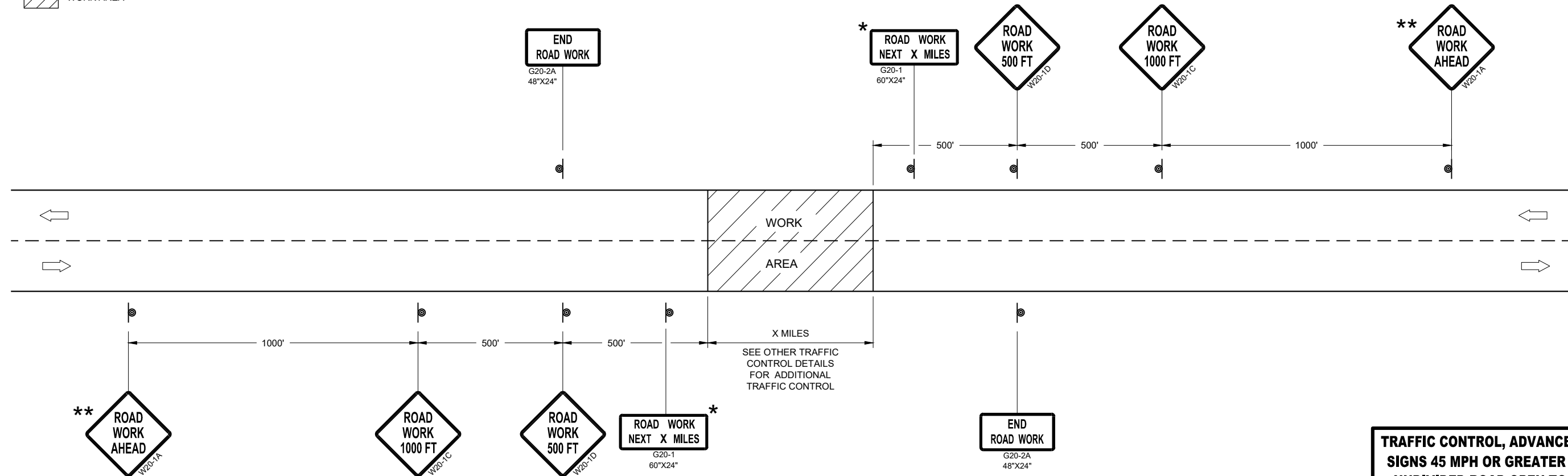

TRAFFIC CONTROL, ADVANCE WARNING SIGNS 45MPH OR GREATER

TRAFFIC CONTROL, ADVANCE WARNING SIGNS 45 MPH OR GREATER TWO-WAY UNDIVIDED ROAD OPEN TO TRAFFIC

STATE OF WISCONSIN
DEPARTMENT OF TRANSPORTATION

APPROVED
DATE July 2018 /S/ Andrew Heidtke
WORK ZONE ENGINEER

FHWA

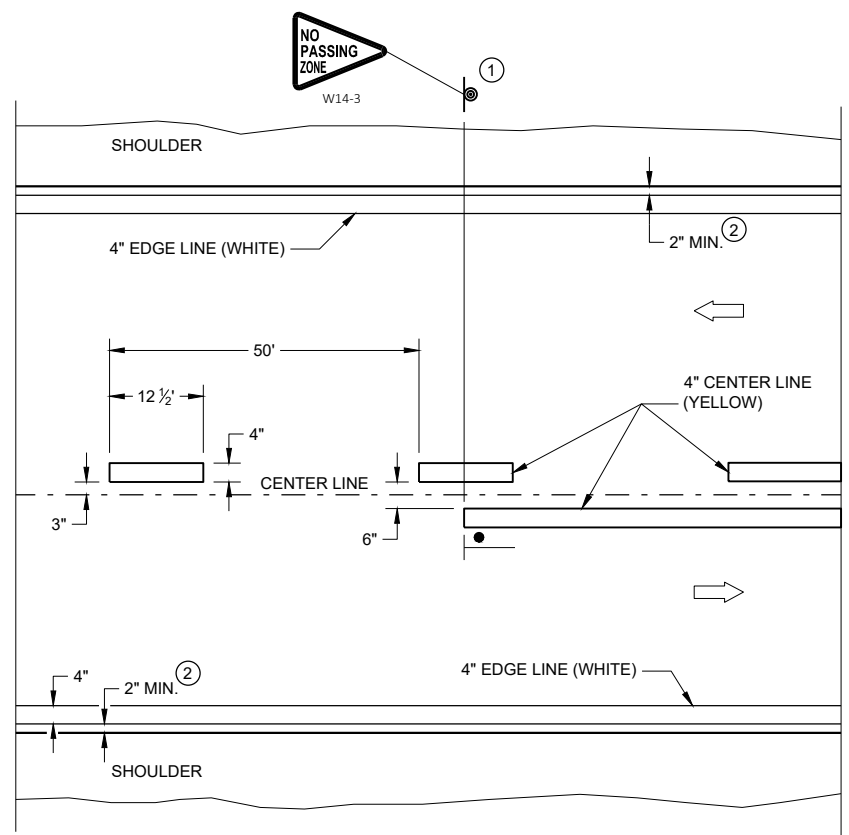

TWO WAY TRAFFIC

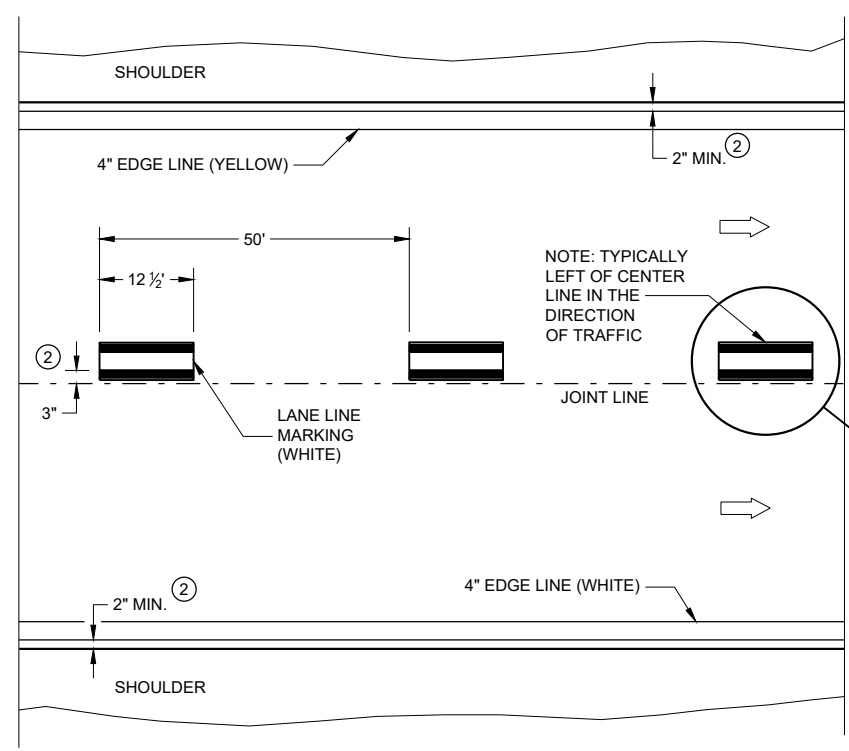

ONE WAY TRAFFIC

PERMANENT PAVEMENT MARKING

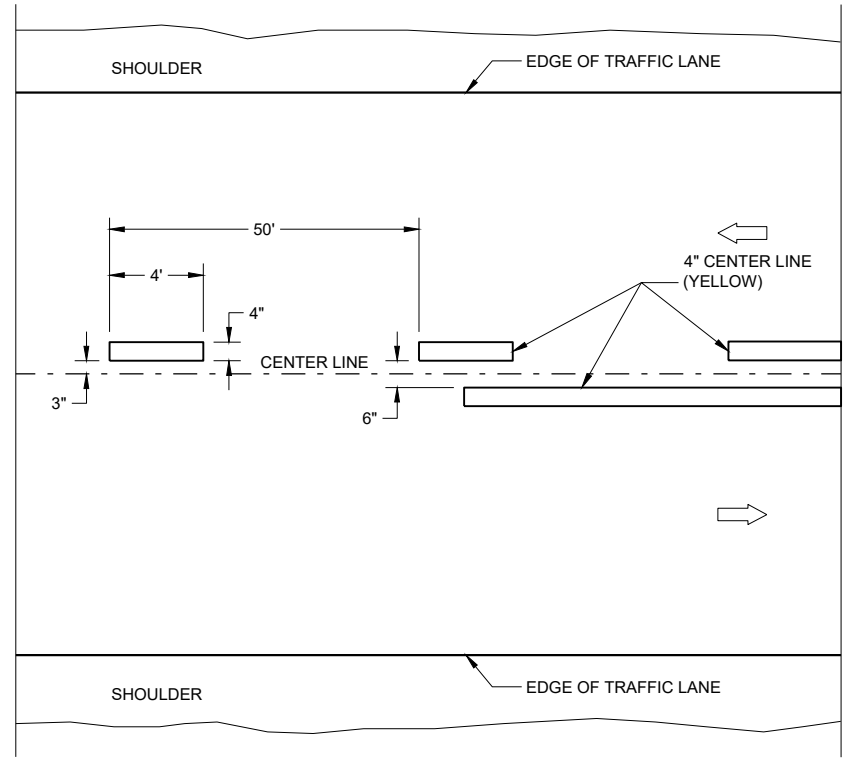

TWO WAY TRAFFIC

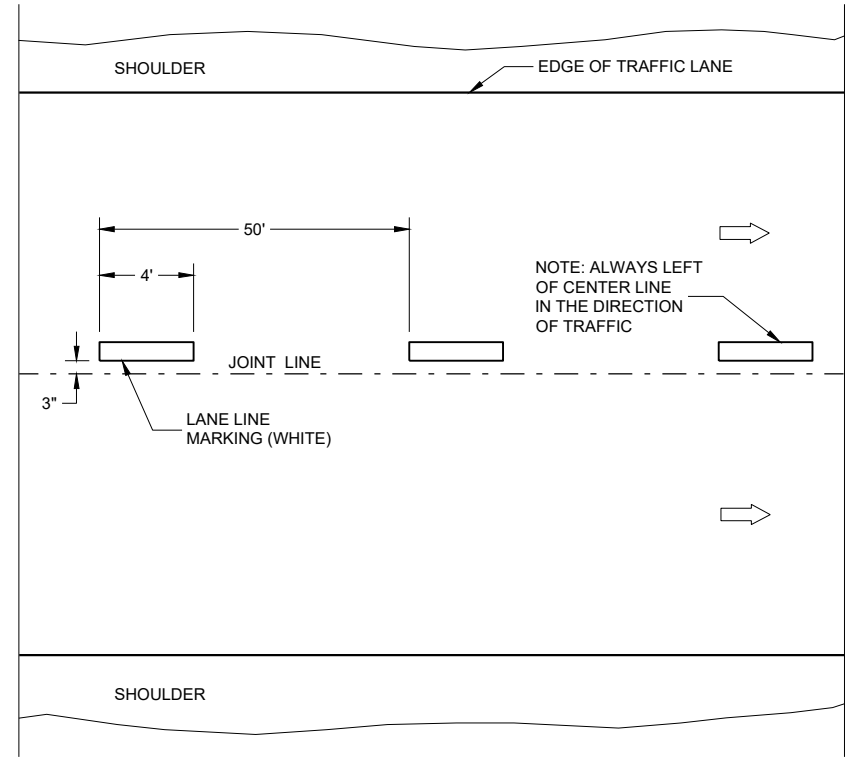

ONE WAY TRAFFIC

TEMPORARY PAVEMENT MARKING

GENERAL NOTES

DETAILS OF CONSTRUCTION NOT SHOWN ON THIS DRAWING SHALL CONFORM TO STANDARD SPECIFICATIONS AND SPECIAL PROVISIONS.

- ① LOCATE THE NO PASSING ZONE W14-3 SIGN WITHIN 50 FEET OF THE "T" MARKING
- ② MEASURE FROM EDGE OF MARKING TO JOINT LINE. THIS DOES NOT INCLUDE SPACE NEEDED FOR GROOVING OPERATIONS.

LEGEND

- "T" MARKING
- SIGN ON PERMANENT SUPPORT
- DIRECTION OF TRAFFIC

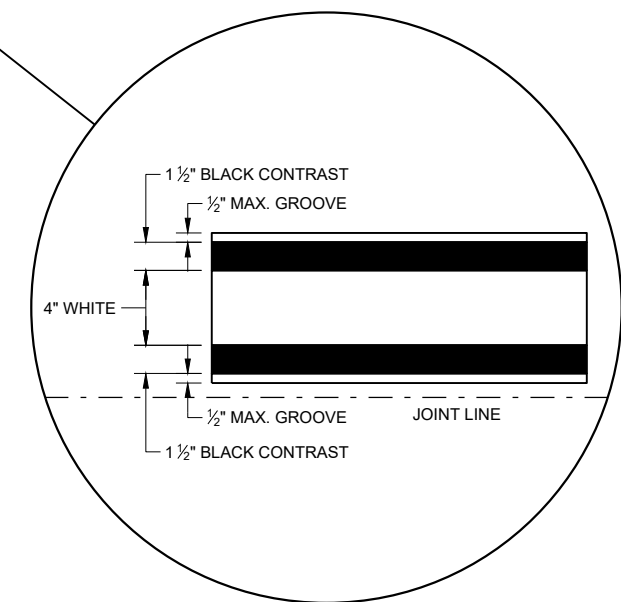





LONGITUDINAL MARKING (MAINLINE)

STATE OF WISCONSIN DEPARTMENT OF TRANSPORTATION

APPROVED
 February 2020 /S/ Matthew Rauch
 DATE STATEWIDE SIGNING AND MARKING ENGINEER
 FHWA

LEGEND

-  SIGN ON PORTABLE OR PERMANENT SUPPORT
-  TEMPORARY PORTABLE RUMBLE STRIP ARRAY
-  DIRECTION OF TRAFFIC
-  WORK AREA
-  FLAGGER, EQUIPPED WITH STOP/SLOW PADDLE FASTENED ON SUPPORT STAFF

GENERAL NOTES

DETAILS OF TRAFFIC CONTROL DEVICES AND INSTALLATION NOT SHOWN ON THIS DRAWING SHALL CONFORM TO THE PERTINENT REQUIREMENTS OF THE STANDARD SPECIFICATIONS, THE SPECIAL PROVISIONS, AND THE MANUAL ON UNIFORM TRAFFIC CONTROL DEVICES.

ALL SIGNS ARE 48" X 48" UNLESS OTHERWISE NOTED.

"WO" SIGNS ARE THE SAME AS "W" SIGNS EXCEPT THE BACKGROUND IS ORANGE.

THE EXACT NUMBER, LOCATION AND SPACING OF ALL SIGNS, DEVICES, AND LOCATION OF ALL FLAGGERS SHALL BE ADJUSTED TO FIT FIELD CONDITIONS AS APPROVED BY THE ENGINEER.

THE FIRST ADVANCE WARNING SIGN SHOULD TYPICALLY BE LOCATED IN ADVANCE OF THE ANTICIPATED TRAFFIC BACKUP OR QUEUE.

WHEN A SIDE ROAD OR RAMP INTERSECTS THE FACILITY ON WHICH THE WORK IS BEING PERFORMED, ADDITIONAL TRAFFIC CONTROLS SHALL BE PROVIDED AS SPECIFIED IN THE PLANS AND/OR THE SPECIAL PROVISIONS OR AS APPROVED BY THE ENGINEER.

FLAGGING

FLAGGERS SHALL BE IN SIGHT OF EACH OTHER OR IN DIRECT COMMUNICATION AT ALL TIMES. THEY SHALL BE EQUIPPED WITH STOP/SLOW PADDLES FASTENED ON SUPPORT STAFFS. WHEN THE FLAGGING OPERATION IS NOT IN EFFECT REMOVE TEMPORARY PORTABLE RUMBLE STRIPS PRIOR TO COVERING OR REMOVING ALL ADVANCE SIGNING.

- ① FOR MOVING WORK OPERATIONS, POST ADDITIONAL W20-7A FLAGGER SIGNS AT APPROXIMATELY 3,500' INTERVALS IN THE MOVING WORK OPERATION OR AS APPROVED BY THE ENGINEER.
- ② SIGN NOT REQUIRED IF FLAGGING OPERATION OCCURS WITHIN A SIGNED ROAD WORK ZONE AREA.

WHEN THE DISTANCE BETWEEN FLAGGERS EXCEEDS 2 MILES, A PILOT CAR IS REQUIRED. WHEN CURVES REDUCE SIGHT DISTANCE BELOW 400', A PILOT CAR IS REQUIRED.

TEMPORARY PORTABLE RUMBLE STRIPS

UTILIZE TEMPORARY PORTABLE RUMBLE STRIPS ON ALL FLAGGING OPERATIONS.

- ③ EACH TEMPORARY PORTABLE RUMBLE STRIP ARRAY CONSISTS OF THREE RUMBLE STRIPS PLACED TRANSVERSE ACROSS THE LANE AT THE LOCATIONS SHOWN. WITHIN EACH ARRAY, SPACING BETWEEN RUMBLE STRIPS SHALL BE 15 FEET ON CENTER

ONLY USE TEMPORARY PORTABLE RUMBLE STRIPS FROM THE APPROVED PRODUCTS LIST.

INSTALL TEMPORARY RUMBLE STRIPS PER MANUFACTURER'S RECOMMENDATIONS.

PLACE ADVANCE SIGNING PRIOR TO INSTALLING TEMPORARY RUMBLE STRIPS.

DO NOT INSTALL TEMPORARY PORTABLE RUMBLE STRIPS ON GRAVEL, MILLED SURFACES, OR ASPHALT THAT HAS BEEN PAVED LESS THAN 12 HOURS.

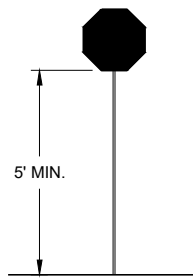

STOP/SLOW PADDLE ON SUPPORT STAFF

SIGN AND TEMPORARY RUMBLE STRIP ARRAY SPACING TABLE

SPEED LIMIT	SPACING "A"
25-30 MPH	200'
35-40 MPH	350'
45-55 MPH	500'



WO3-4

USE OF WO3-4 SIGN IS OPTIONAL. WHEN USED, THIS SIGN SHALL BE LOCATED BETWEEN THE W20-7A AND W20-4A SIGNS, USING SPACING "A".

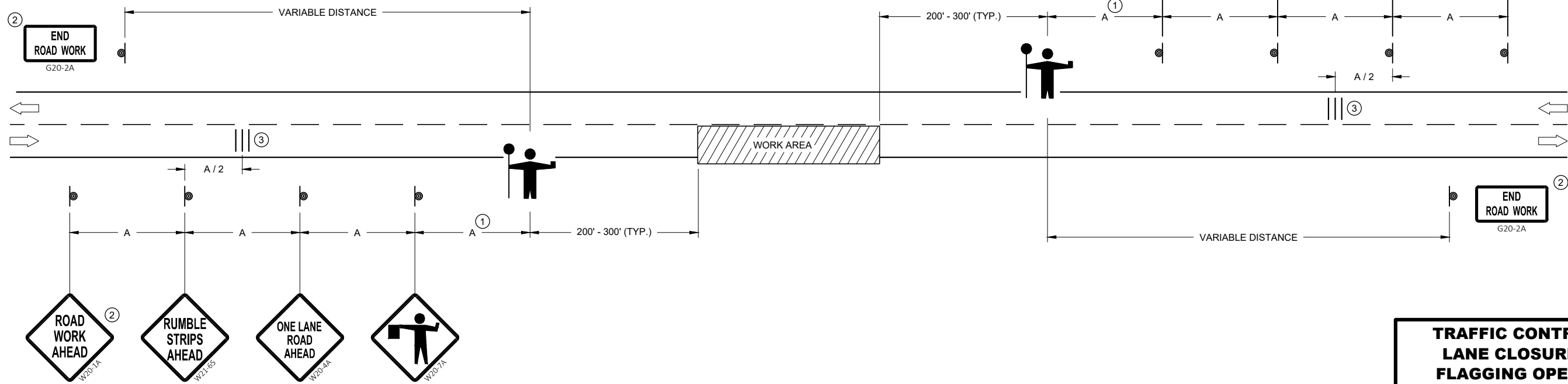

TRAFFIC CONTROL FOR LANE CLOSURE WITH FLAGGING OPERATION

STATE OF WISCONSIN
DEPARTMENT OF TRANSPORTATION

APPROVED
November 2021 /S/ Andrew Heidtke
DATE WORK ZONE ENGINEER

FHWA

GENERAL NOTES

OMIT EDGE LINES THROUGH INTERSECTIONS. CONTINUE EDGE LINES THROUGH DRIVEWAYS.

- ① WHEN DISTANCE "A" IS LESS THAN 250 FEET, OMIT LANE LINE.
- ② WHEN DISTANCE "B" IS LESS THAN 100 FEET, OMIT CHANNELIZING LANE LINE.
- ③ BARRIER LINE ENDS AT SIDE ROAD PAVEMENT / SURFACE EDGE EXTENSION.
- ④ BARRIER LINE STARTS 500 FEET PRIOR TO THE BYPASS TAPER.

LEGEND

➡ DIRECTION OF TRAVEL

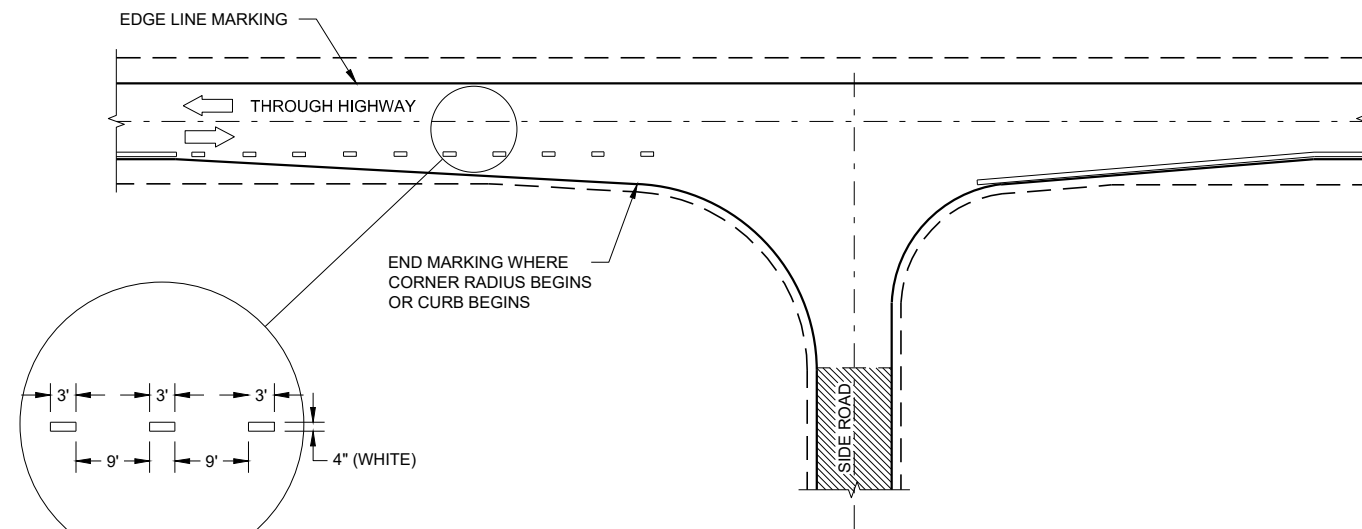

MINOR INTERSECTION

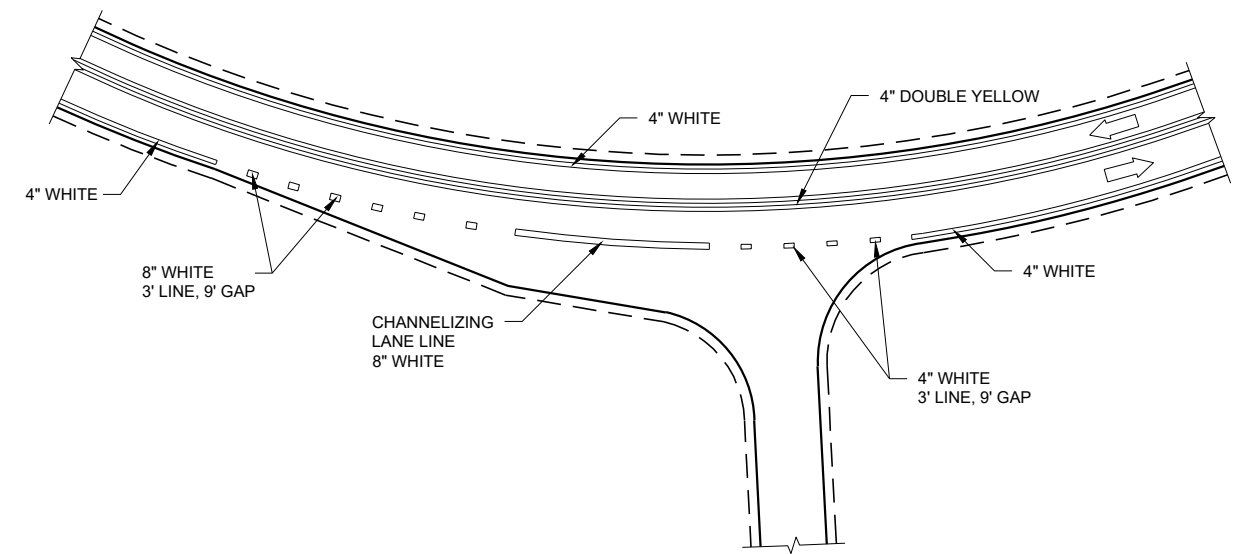

INTERSECTION ON OUTSIDE OF CURVE

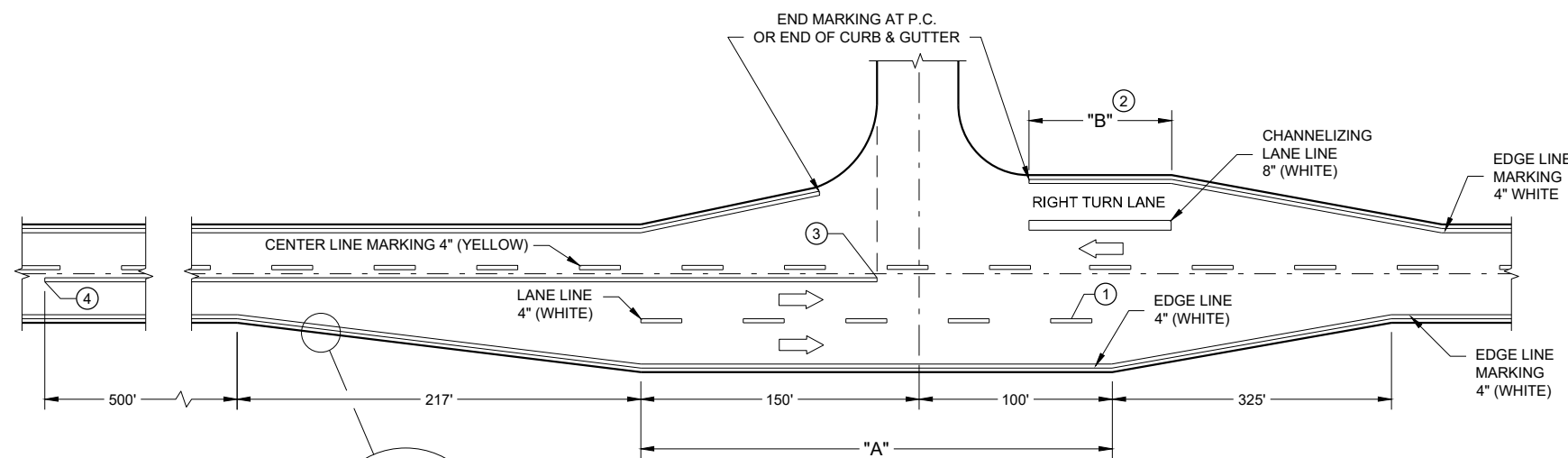

**MAJOR INTERSECTIONS
(INTERSECTION WITH FULL RIGHT TURN LANE OR BYPASS LANE)**

**PAVEMENT MARKING
(INTERSECTIONS)**

STATE OF WISCONSIN
DEPARTMENT OF TRANSPORTATION

TYPICAL ASSEMBLIES

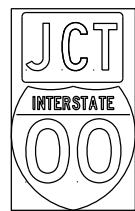

J1-1

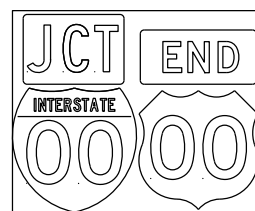

J1-2

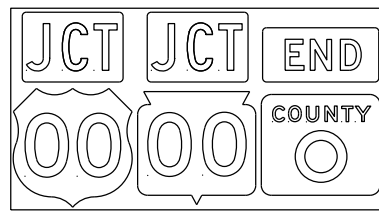

J1-3



JR1-1

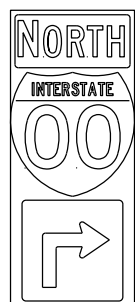

J2-1

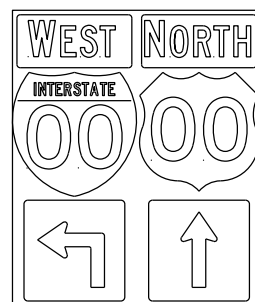

J2-2

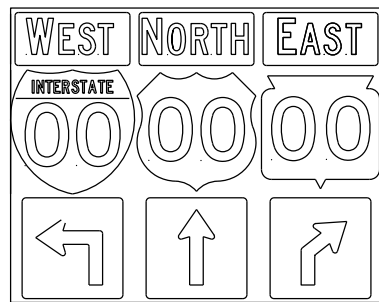

J2-3

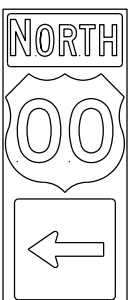

J3-1

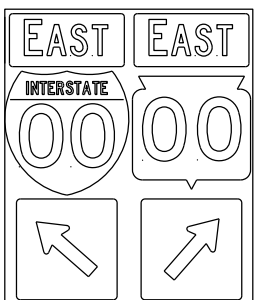

J3-2

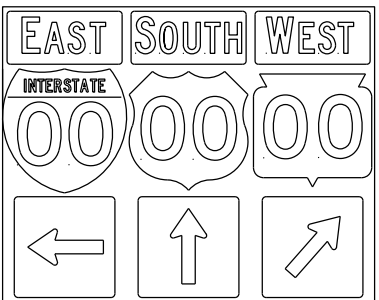

J3-3

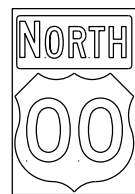

J4-1

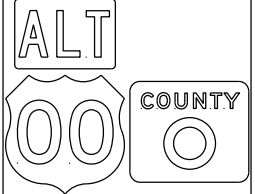

J4-2

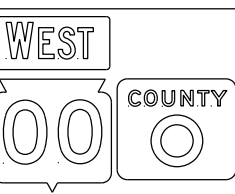

J4-2



J12-1

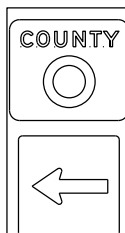

J13-1

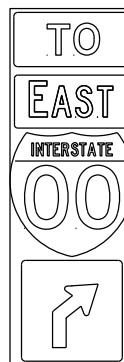

J32-1

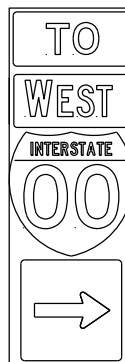

J33-1

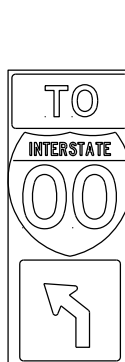

J22-1

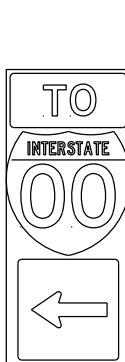

J23-1



JR13-1



JR23-1



JR99-1



JV

(Typical Vertical J-Assembly See Note 10 and 11)

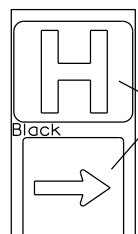

JH-1

Blue Background

blue background with interstate

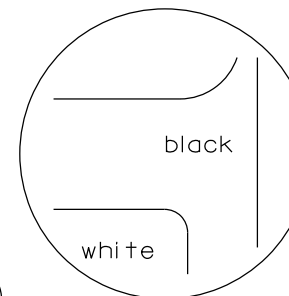
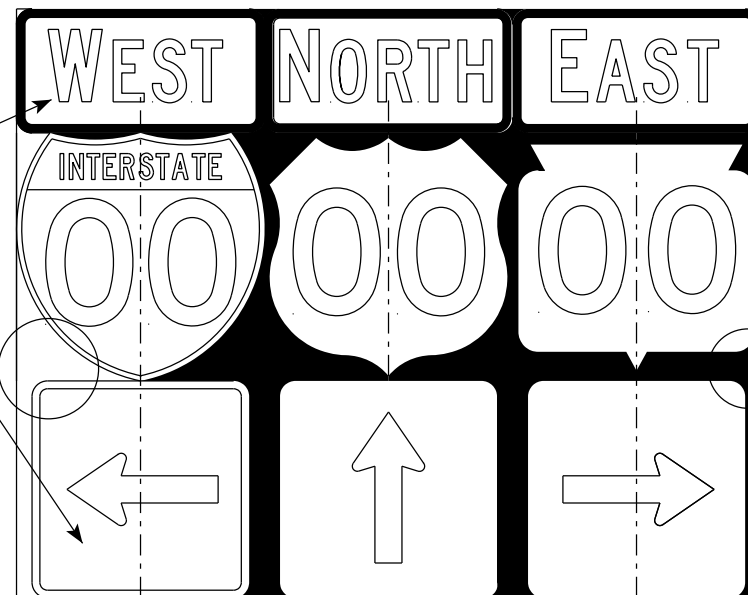
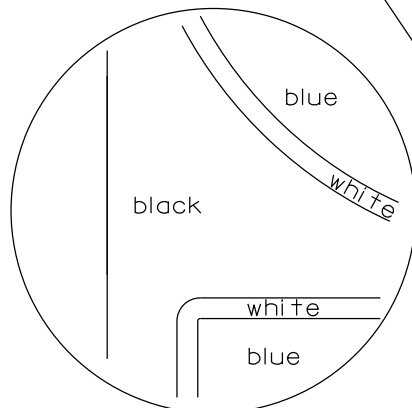

black background

NOTES

- Signs are Type II - Type H Reflective
- Color:
 - Background - Black Non-reflective
 - Message - see Note 5
- Message Series - See Note 5
- Corners shall be square or rounded if base material is plywood. If base material is metal the corners shall be rounded.
- The colors and message spacing on each marker shall be according to the applicable route marker panel specifications.
- Certain marker heads require the component pieces to be the same color. As an example, all the components used with an MI-1 Interstate marker shall be blue.
- Single panel j-assemblies shall only be used with route marker shields that are same size. If the route marker shields are different size use multiple piece component.
- Route assemblies that have 24 inch route shields and have dimensions greater than 48 inches (both vertical and horizontal) shall have one horizontal splice between the arrows and route shields. Vertical splices shall not be used on route assemblies with a horizontal dimension of 144 inches or less. The contractor shall not use more than one vertical joint per sign and the joint shall be between route shields.
- Route assemblies that have 36 inch shields and have dimensions greater than 48 inches (both vertical and horizontal) shall have two horizontal splices. One horizontal splice shall be between the cardinal direction and route shields and the other horizontal splice shall be between the arrows and route shields. Vertical splices shall not be used on route assemblies with a horizontal dimension of 144 or less. The contractor shall not use more than one vertical joint per sign and the joint shall be between route shields.
- All Vertical J Assemblies are given a Sign Code of JV
- For JV Assemblies that have a mixture of Interstate and non Interstate shields, arrows and cardinals shall be white on blue.

7

7

PROJECT NO:

FILE NAME : C:\CAEfiles\Projects\tr_stdplote_A21S.dgn

PLOT DATE : 18-MAR 2021 1:37

PLOT BY : mscj9h

PLOT NAME :

SHEET NO:

E

ROUTE MARKERS & COMPONENTS
IN TYPICAL ASSEMBLIES

WISCONSIN DEPT OF TRANSPORTATION

APPROVED

Matthew R. Rauch
for State Traffic Engineer

DATE 3/18/21

PLATE NO. A2-1S.9

WISDOT/CADDs SHEET 42

URBAN AREA

RURAL AREA (See Note 2)

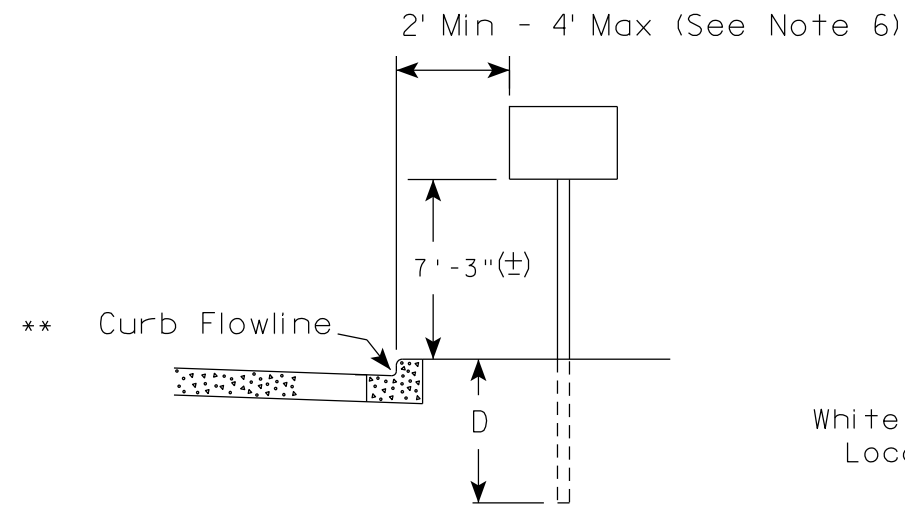

White Edgeline Location

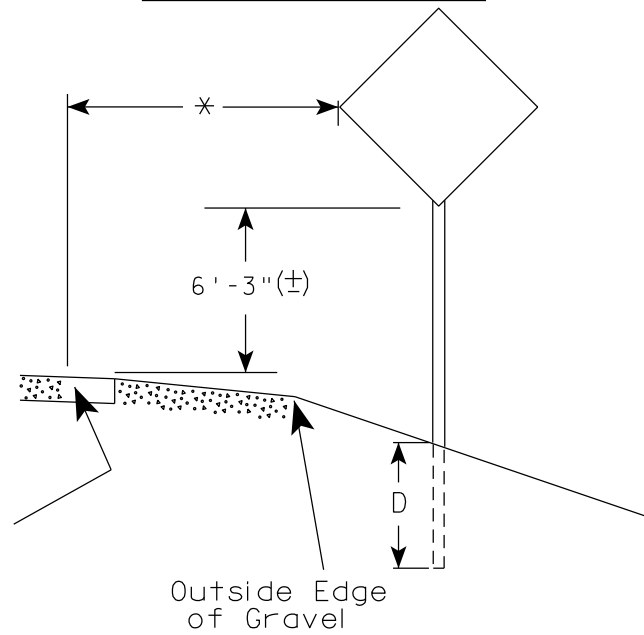

Outside Edge of Gravel

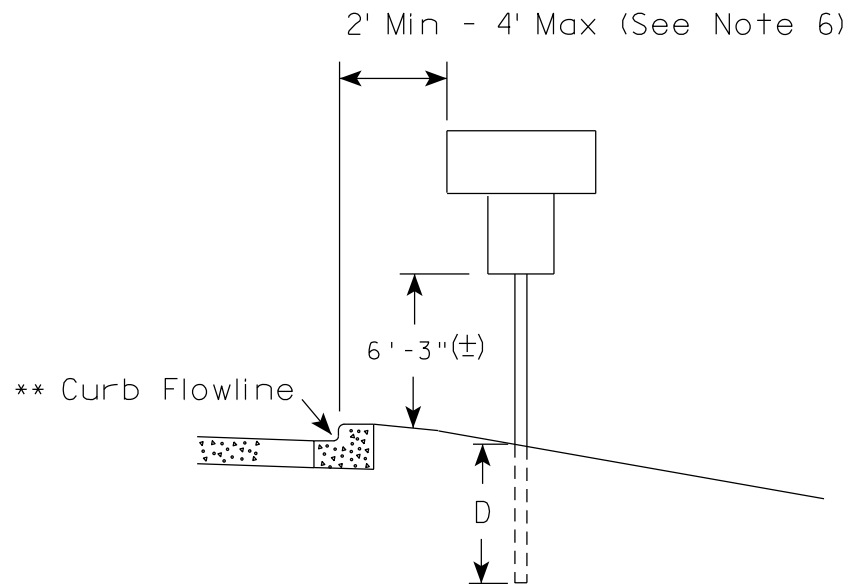

White Edgeline Location

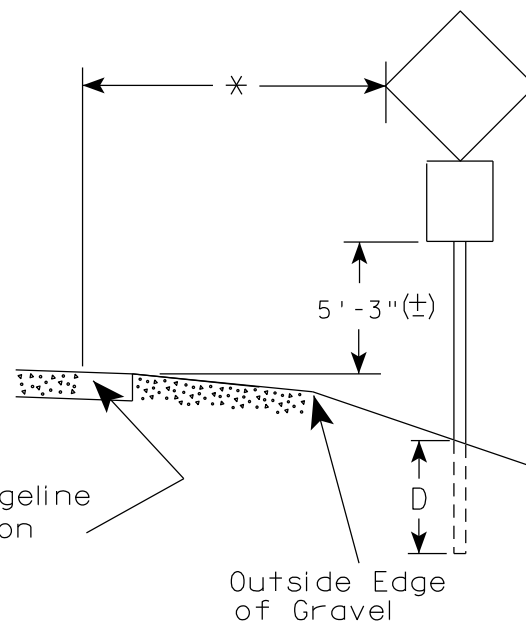

Outside Edge of Gravel

POST EMBEDMENT DEPTH

Area of Sign Installation (Sq. Ft.)	D (Min)
20 or Less	4'
Greater than 20	5'

GENERAL NOTES

1. Signs wider than 4 feet or 20 sq.ft or larger, shall be mounted on multiple posts. Refer to plate A4-4.
2. If signs are mounted on or behind barrier wall, see A4-10 sign plate.
The Double Arrow sign (W12-1D) shall be mounted at a height of 2'-3" (±). The Chevron sign (W1-8), Roundabout Chevron panel (R6-4B), Enhanced Reference Markers, Clearance Markers (W5-52), Mile Markers (D10 series), In Road Object Markers (W5-54) & End of Road Markers (W5-56) shall be mounted at a height of 4'-3" (±).
3. For expressways and freeways, mounting height is 7'- 3" (±) or 6'-3" (±) depending upon existence of a sub-sign.
4. Minimum mounting height for signs mounted on traffic signal poles is 5'- 3" (±).
5. Offset distance shall be consistent with existing signs or consistent throughout length of project.
6. The (±) tolerance for mounting height is 3 inches.
7. Folding signs shall be mounted at a height of 5'-3" (±) or as directed by the Engineer.

7

7

* * The existence of curb and gutter does not in itself mandate the vertical clearance illustrated. That height is typically measured where there is sidewalk adjacent to the roadway or parking is permitted. In the absence of sidewalk vertical clearance is measured from the top of the curb. Offset of signs is measured from the flow line.

* 6 feet from edge of a paved shoulder or 12 feet from the edge of pavement (edge line location) or 2 feet from outside edge of gravel, whichever is greater unless directed by project engineer.

TYPICAL INSTALLATION OF PERMANENT TYPE II SIGNS ON SINGLE POSTS

WISCONSIN DEPT OF TRANSPORTATION

APPROVED *Matthew R. Rauch*
for State Traffic Engineer

DATE 5/13/2020 PLATE NO. A4-3.22



ELEVATION VIEW

DETAIL OF WOOD 4 X 6 SIGN POST IN BOX-OUT

- NOTES:**
1. ALL MATERIAL TO BE APPROVED BY ENGINEER PRIOR TO INSTALLATION
 2. SEE SIGN PLATE A4-8 FOR SIGN HARDWARE REQUIREMENTS
 3. 18 INCH X 18 INCH SQUARE BOX-OUTS MAY BE USED FOR INSTALLATIONS IN EXISTING CONCRETE OR ASPHALT LOCATIONS.



ELEVATION VIEW

DETAIL OF STEEL 2 X 2 SIGN POST IN BOX-OUT



PLAN VIEW

FOR NEW CONCRETE/ ASPHALT INSTALLATIONS

SIGN POST BOX-OUTS A4-3B	
<small>WISCONSIN DEPT OF TRANSPORTATION</small>	
APPROVED <i>Matthew R. Rauch</i> <small>for State Traffic Engineer</small>	
<small>DATE 1/27/14</small>	<small>PLATE NO. A4-3B.1</small>

GENERAL NOTES

1. For 3 or 4 post installations, individual post spacing shall be greater than 3'-6".
2. See tables below for required number of posts.
3. For expressways and freeways, mounting height is 7'-3" (±) or 6'-3" (±) depending upon existence of sub-sign.
4. The (±) tolerance for mounting height is 3 inches.
5. J-Assemblies are considered to be one sign for mounting height.
6. Offset distance shall be consistent with existing signs or consistent throughout length of project.
7. Folding signs shall be mounted at a height of 5'-3" (±) or as directed by the engineer.
8. The Double Arrow sign (W12-1) shall be mounted at a height of 2'-3" (±). The Chevron sign (W1-8), Roundabout Chevron panel (R6-4B), Clearance Markers (W5-52), Mile Markers (D10 series), In Road Object Markers (W5-54) & End of Road Markers (W5-56) shall be mounted at a height of 4'-3" (±).

URBAN AREA

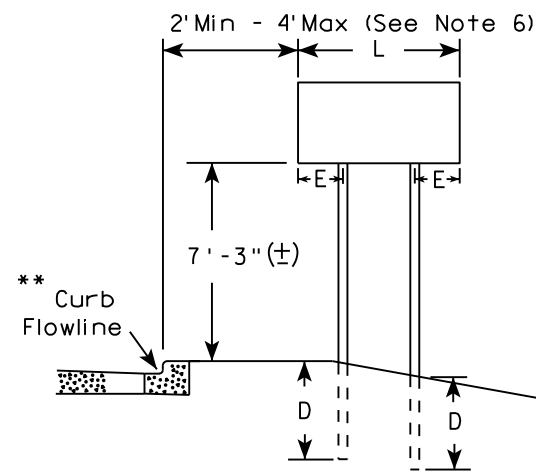

RURAL AREA (See Note 3)

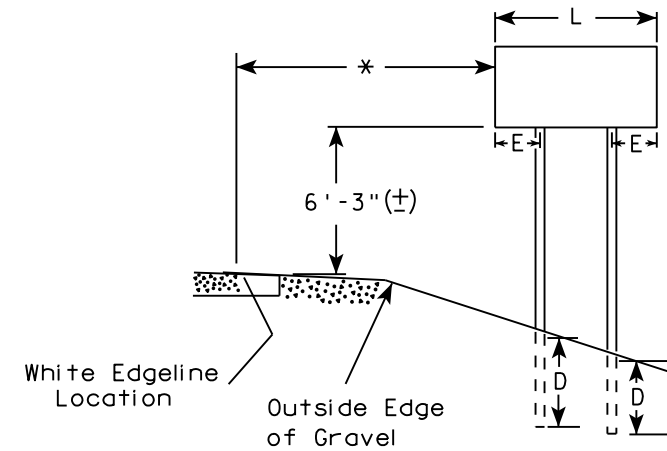

2' Min - 4' Max (See Note 6)

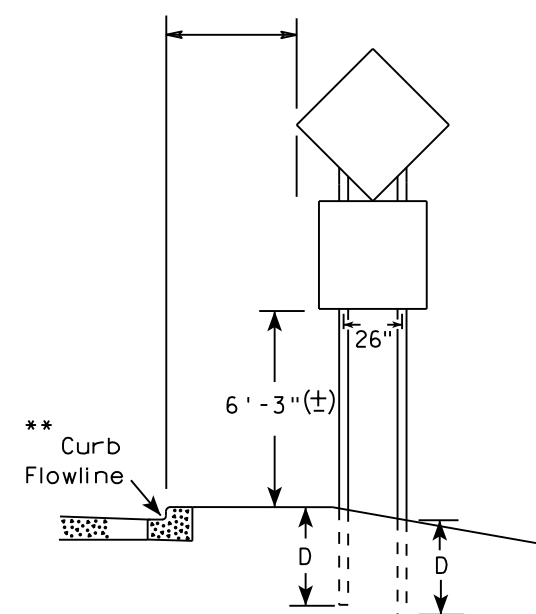

48" DIAMOND WARNING SIGN

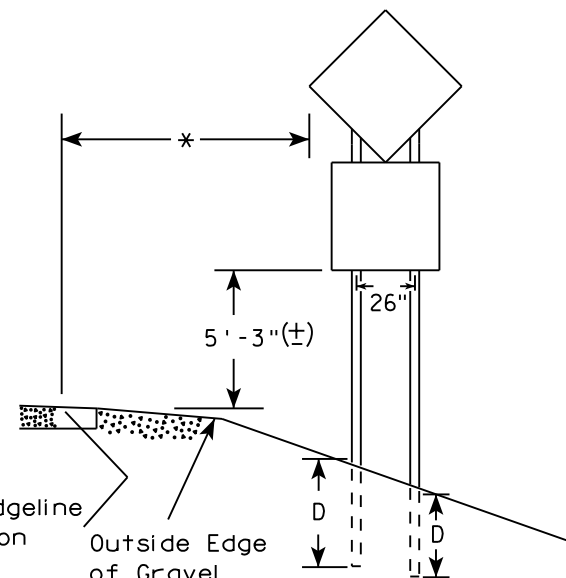

48" DIAMOND WARNING SIGN

* 6 feet from edge of a paved shoulder or 12 feet from the edge of pavement (edge line location) or 2 feet from outside edge of gravel, whichever is greater unless directed by project engineer.

** The existence of curb and gutter does not in itself mandate the vertical clearance illustrated. That height is typically measured where there is sidewalk adjacent to the roadway or parking is permitted. In the absence of sidewalk vertical clearance is measured from the top of the curb. Offset of signs is measured from the flow line.

*** See A4-3 sign plate for signs 4' or less in width and less than 20 S.F. in area.

SIGN SHAPE OTHER THAN DIAMOND (TWO POSTS REQUIRED)	
L	E
Greater than 48" Less than 60"	12"
60" to 108"	L/5

SIGN SHAPE OTHER THAN DIAMOND (THREE POSTS REQUIRED)	
L	E
Greater than 108" to 144"	12"

POST EMBEDMENT DEPTH

Area of Sign Installation (Sq. Ft.)	D (Min)
20 or Less	4'
Greater than 20	5'

TYPICAL INSTALLATION OF TYPE II SIGNS ON MULTIPLE POSTS

WISCONSIN DEPT OF TRANSPORTATION
 APPROVED *Matthew R. Rauch*
 For State Traffic Engineer
 DATE 8/21/17 PLATE NO. A4-4.15

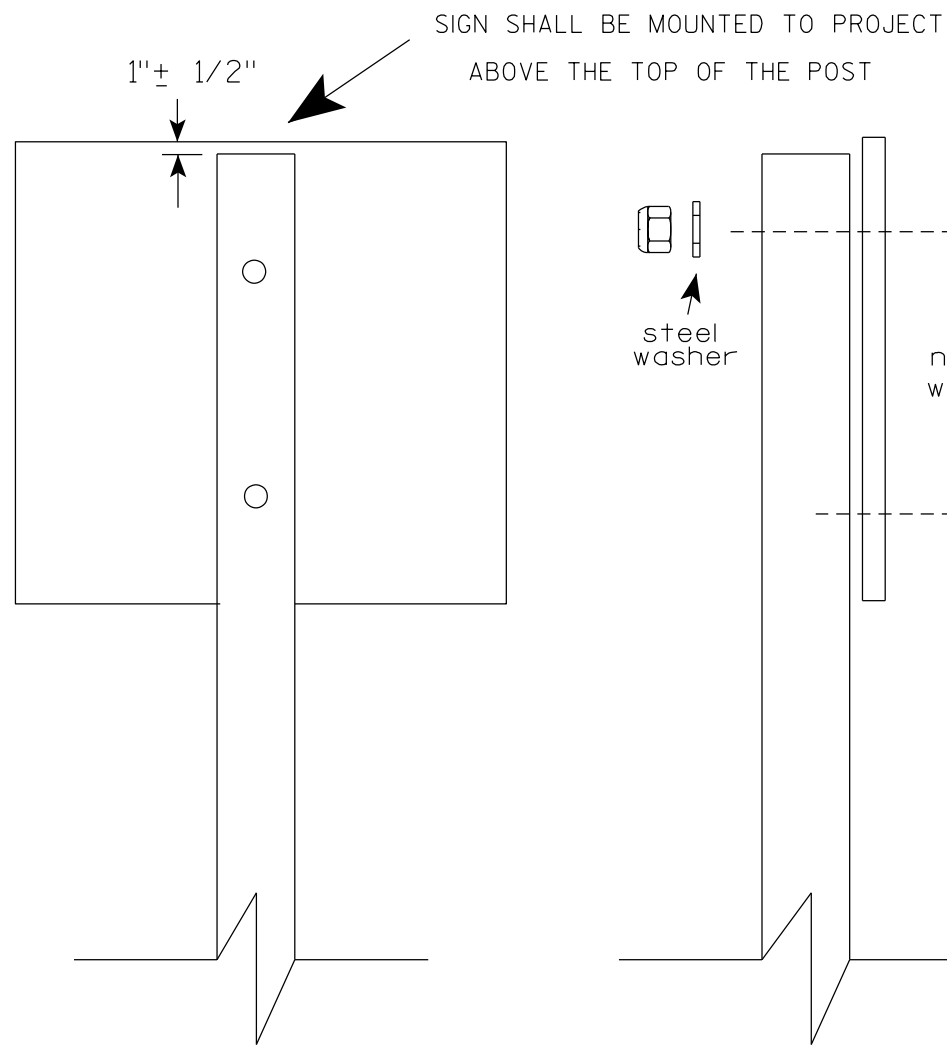

Nuts, bolts and lags used for mounting signs shall have hexagonal heads and shall be either :

- a. Hot dip galvanized in accordance with ASTM Designation: A 153, Class D, or SC 3
- b. Electro-galvanized in accordance with ASTM Designation : B 633, TYPE III, SC 3.

Threads on bolts and nuts shall be manufactured with sufficient allowance for the cadmium plate or galvanized coating to permit the nuts to run freely on the bolts.

STRINGER BOLTING TO ALUMINUM SIGNS (SEE SIGN PLATE A4-18)

MACHINE BOLTS - 5/16" X 1-3/4" Length w/ lock nuts

WOOD POSTS (4" x 6")

LAG SCREWS - 3/8" X 3" (NO STRINGERS ON BACK OF SIGN)
3/8" X 4" (STRINGERS ON BACK OF SIGN)

SQUARE STEEL POSTS (2" x 2")

MACHINE BOLTS - 3/8" X 3-1/4" Length w/ nuts (NO STRINGER ON BACK OF SIGN)
3/8" X 5" Length w/ nuts (STRINGERS ON BACK OF SIGN)

RIVETS - 9/32" (6605-9-6) BULB-TITE, TRI-FOLD, ALUMINUM BODY/MANDREL
O.D. FLANGE .720-.765 INCH, GRIP RANGE .042-.375 INCH

WASHERS (ALL POSTS) -

1-1/4" O.D. X 3/8" I.D. X 1/16" STEEL

1-1/4" O.D. X 3/8" I.D. X .080 NYLON

* Two different fastening systems are shown for illustration purposes. On any individual sign, either one or the other system shall be used. Actual number of fasteners per sign varies with the sign area, but normally there are two. For a single post installation, all signs greater than 9 sq. ft. require the use of 3 fasteners.

ATTACHMENT OF SIGNS
TO POSTS

WISCONSIN DEPT OF TRANSPORTATION

APPROVED *Matthew R Rauch*
For State Traffic Engineer

DATE 4/1/2020 PLATE NO. A4-8.9

**TELESCOPIC TUBING ANCHORS
TWO PIECE SYSTEM**

2 1/4" SQUARE
12 GAUGE
PERFORATED
GALVANIZED FINISH

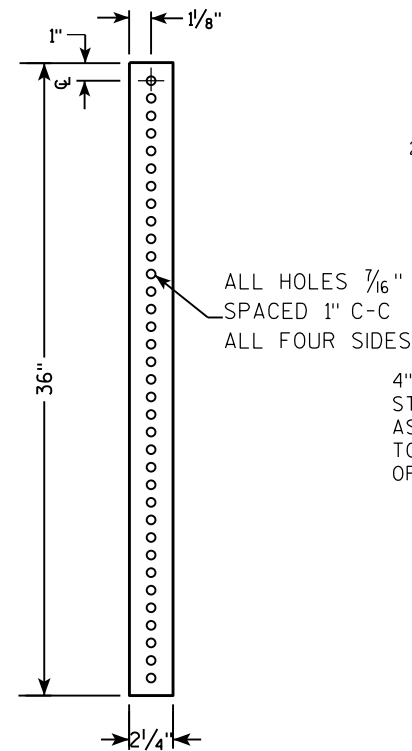

2 1/2" SQUARE
12 GAUGE
OMNI-DIRECTIONAL
PERFORATED
SOIL STABILIZING SLEEVE
GALVANIZED FINISH



**DETAIL OF TUBULAR STEEL SIGN POST
(IN POURED CONCRETE OR ASPHALT)**

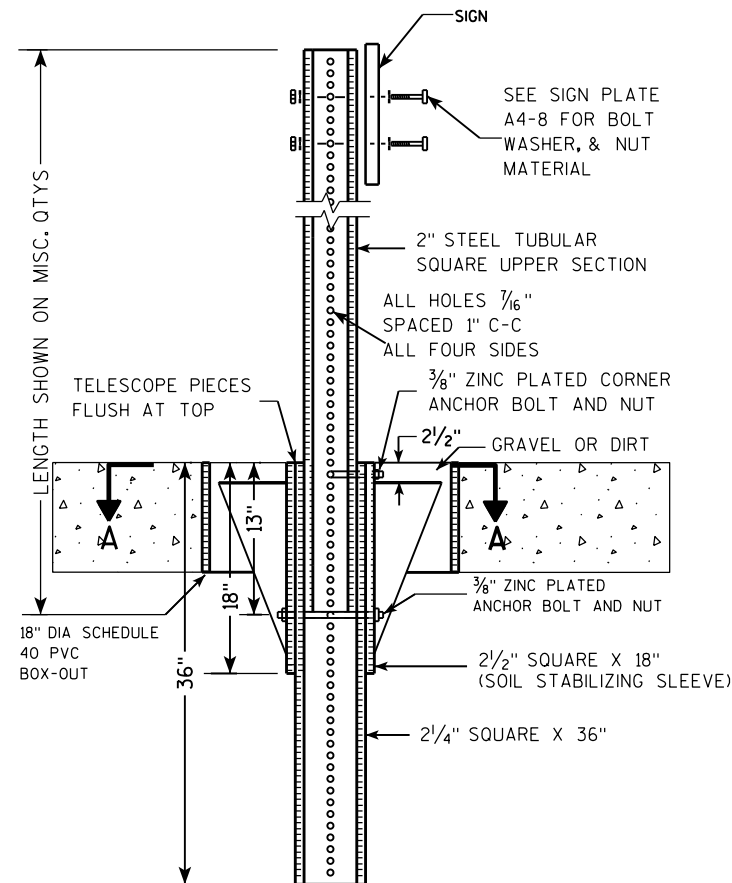

**DETAIL OF TUBULAR STEEL SIGN POST
(IN LOCATIONS OTHER THAN POURED CONCRETE OR ASPHALT)**

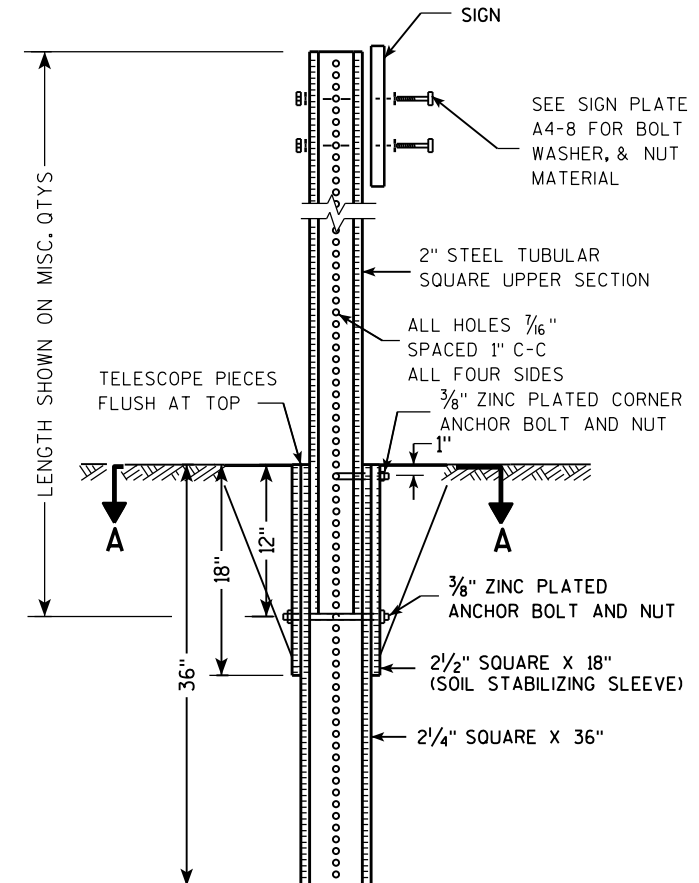

Area of Sign Installation (Sq. Ft.)	Number of Required Posts
9 or less	1
Greater than 9 less than or equal to 18	2
Greater than 18 less than or equal to 27	3

Signs wider than 3 feet or larger than 9 sq. ft shall be mounted on multiple posts (see above table).

**TUBULAR STEEL
SIGN POST
A4-9**

WISCONSIN DEPT OF TRANSPORTATION

APPROVED *Matthew R. Rauch*
for State Traffic Engineer

DATE 2/05/15 PLATE NO. A4-9.9

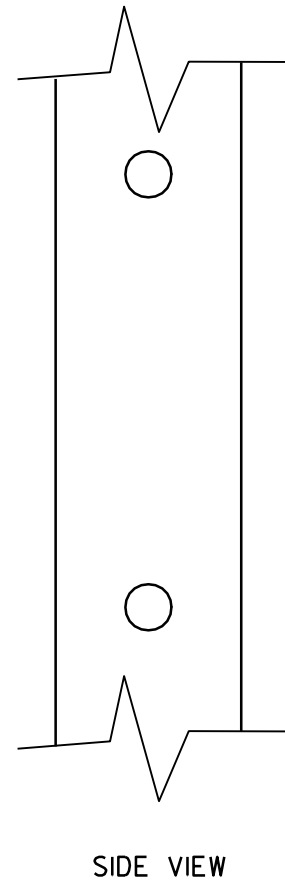
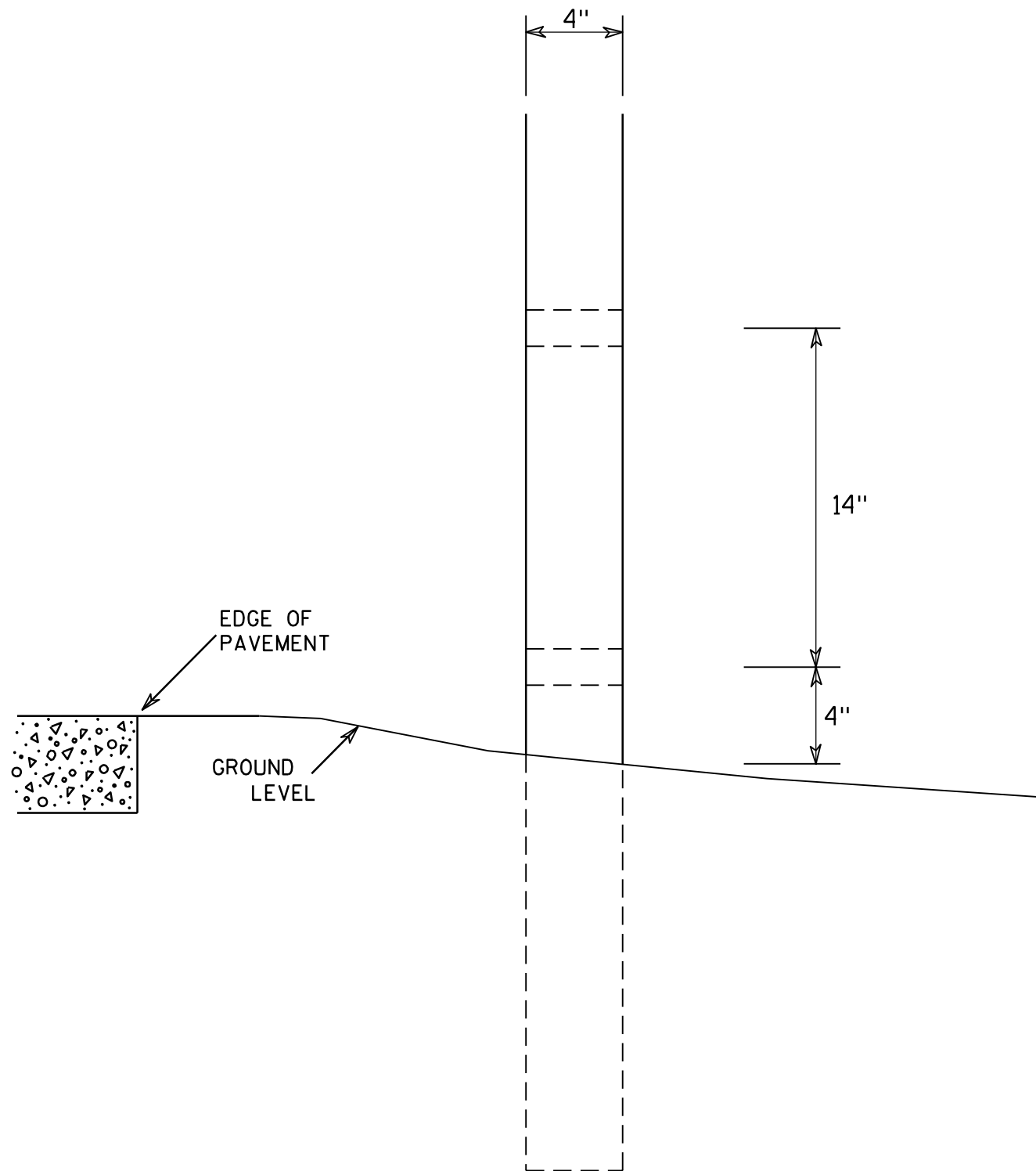

GENERAL NOTES

1. All 4 x 6 Wood Posts shall be modified by having two 1½" diameter holes drilled perpendicular to the roadway centerline.

7

7

4 X 6 WOOD POST MODIFICATIONS	
<i>WISCONSIN DEPT OF TRANSPORTATION</i>	
APPROVED	<i>Chester J Spang</i> for State Traffic Engineer
DATE <u>3/27/97</u>	PLATE NO. <u>A4-11.2</u>

BANDING

SINGLE SIGN

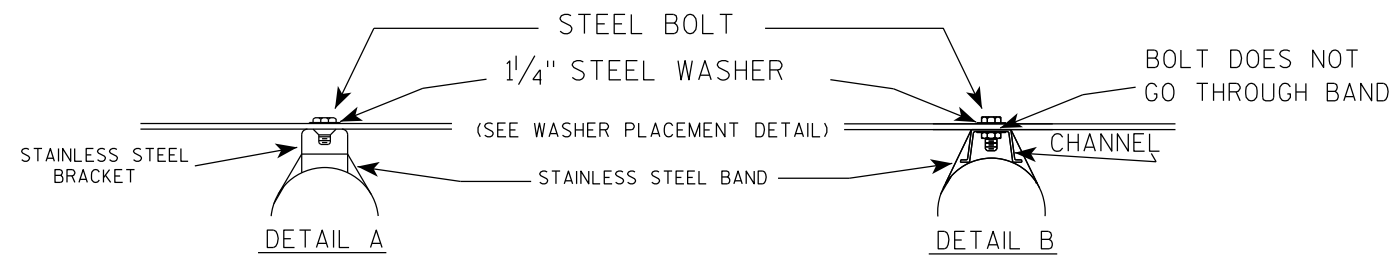
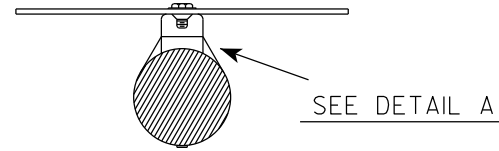
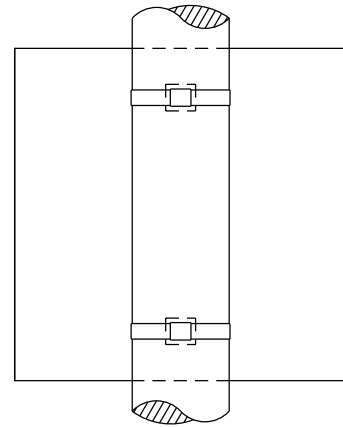

GENERAL NOTES

1. Any sign over 3 feet in width shall use the V-Block banding method. See A5-10 standard plate.
2. Signs 3 feet or greater in height shall have three bracket bands installed. Signs less than 3 feet in height shall have two bracket bands installed.
3. Banding and assembly bracket shall be stainless steel. All bands shall be 3/4" in width and 0.025" thickness.
4. ALL SIGN MOUNTING BOLTS AND WASHERS SHALL BE EITHER:
 - a. Hot dip or mechanically galvanized in accordance with ASTM Designation: A 153, Class D
 - b. Electro-galvanized in accordance with ASTM designation: B 633, Type III, SC 3

"J" ASSEMBLY

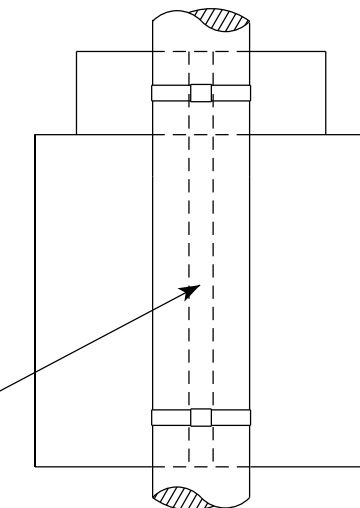

CHANNEL
SEE TYPICAL PANEL
INSTALLATION SHEET



WASHER PLACEMENT

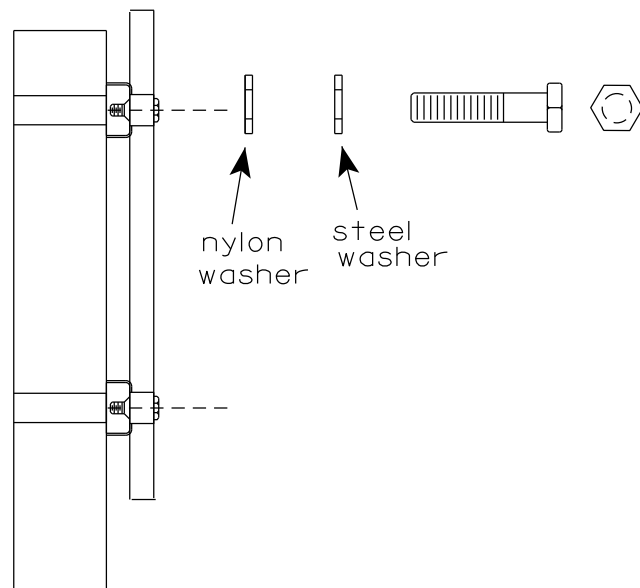

WASHERS (ALL POSTS) -
1-1/4" O.D. X 3/8" I.D. X 1/16" STEEL
1-1/4" O.D. X 3/8" I.D. X .080 NYLON
FOR ALL TYPE H SIGNS

STANDARD SIGN
SIGN BANDING DETAILS

WISCONSIN DEPT OF TRANSPORTATION

APPROVED *Matthew R. Rauch*
for State Traffic Engineer

DATE 6/10/19 PLATE NO. A5-9.4

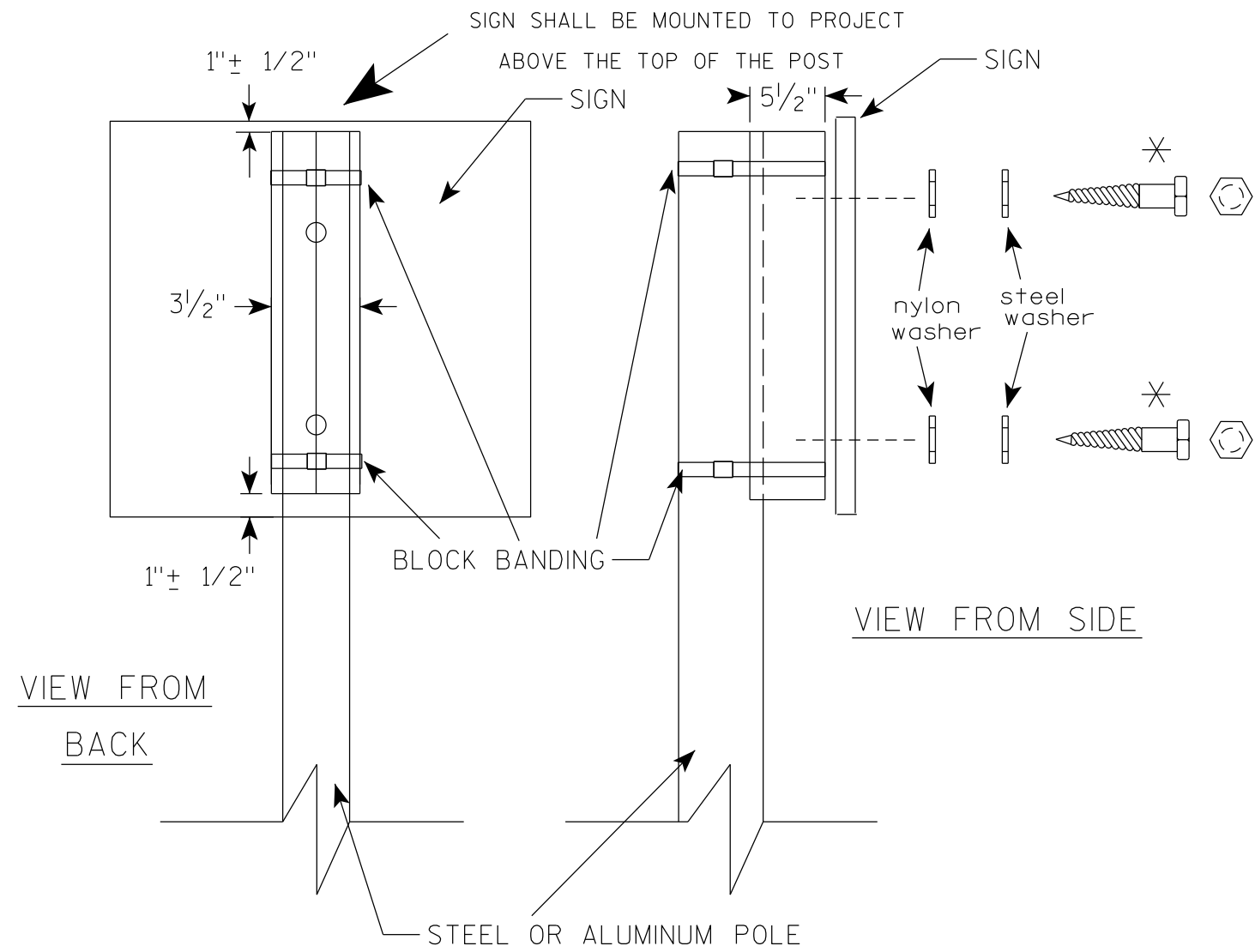

GENERAL NOTES

1. WOOD 4"X6" POST MATERIAL SHALL CONFORM TO 507.2.2 OF THE WisDOT STANDARD SPECIFICATIONS
2. BLOCK BANDING AND CLIPS SHALL BE STAINLESS STEEL, 3/4" WIDTH AND 0.025" THICKNESS
3. SIGNS 3' OR GREATER IN HEIGHT SHALL UTILIZE 3 BLOCK BANDS. SIGNS UNDER 3' IN HEIGHT SHALL UTILIZE 2 BLOCK BANDS
4. ACTUAL NUMBER OF FASTENERS PER SIGN VARIES WITH THE SIGN AREA, BUT NORMALLY THERE ARE TWO. FOR SIGNS GREATER THAN 9 S.F. 3 FASTENERS SHALL BE USED.
5. ALL SIGN MOUNTING BOLTS AND WASHERS SHALL BE EITHER:
 - a. Hot dip or mechanically galvanized in accordance with ASTM Designation: A 153, Class D
 - b. Electro-galvanized in accordance with ASTM Designation : B 633, TYPE III, SC 3
6. ALL BOLTS SHALL HAVE HEXAGONAL HEADS.
7. STEEL WASHERS SHALL BE 1 1/4" O.D. X 3/8" I.D. X 1/16"
8. NYLON WASHERS SHALL BE 1 1/4" O.D. X 3/8" I.D. X .080 FOR TYPE H OR TYPE F FACE SIGN

✱ LAG BOLTS SHALL BE 3/8" X 2 1/2"

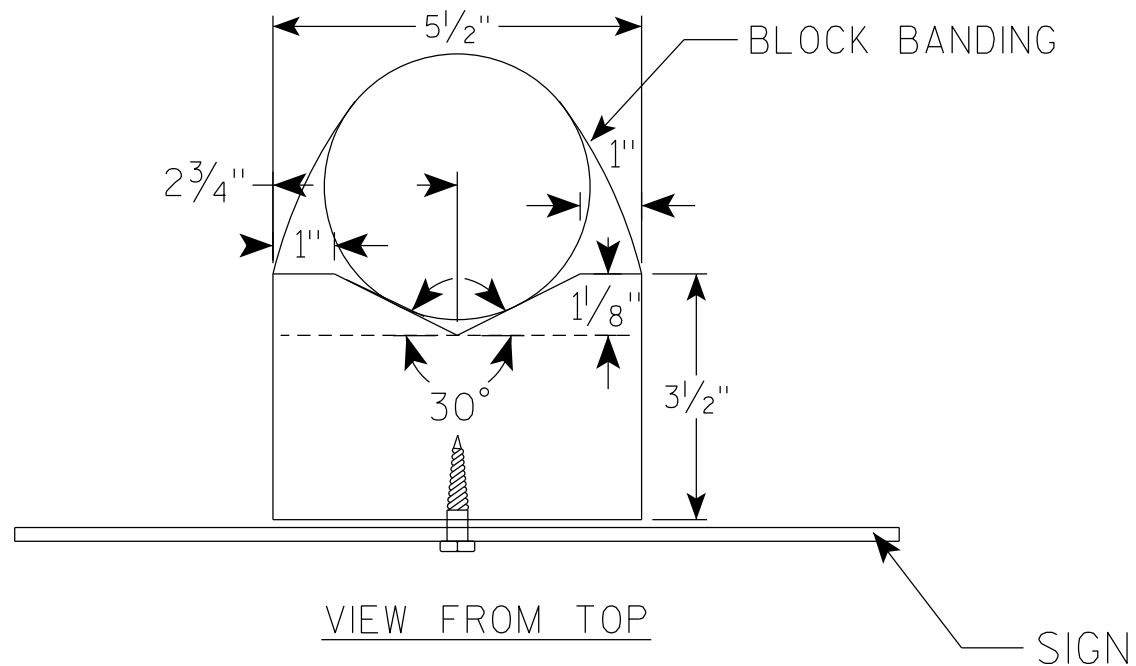

BLOCK BANDING DETAIL (V-BLOCK OPTION)	
WISCONSIN DEPT OF TRANSPORTATION	
APPROVED	<i>Matthew R Rauch</i> For State Traffic Engineer
DATE <u>6/10/19</u>	PLATE NO. <u>A5-10.2</u>

NOTES

1. Sign is Type II - see Note 7 - reference WIS DOT Standard Specification for HIGHWAY and STRUCTURE CONSTRUCTION latest edition.
2. Color:
Background - White & Black - See Note 7
Message - Black
3. Message Series - see Note 5
4. Corners may be square or rounded when base material is plywood but borders shall be rounded as shown. When base material is metal, the corners and borders shall be rounded.
5. Message Series E for 1 letter.
Message Series D for 2 letters unless message is too big then Series C.
Message Series C for 3 letters unless message is too big then Series B.
6. Substitute appropriate letters & optically center to achieve proper balance.
7. Permanent Signs
Background - Type H Reflective
Detour or temporary Signs
Background - Reflective

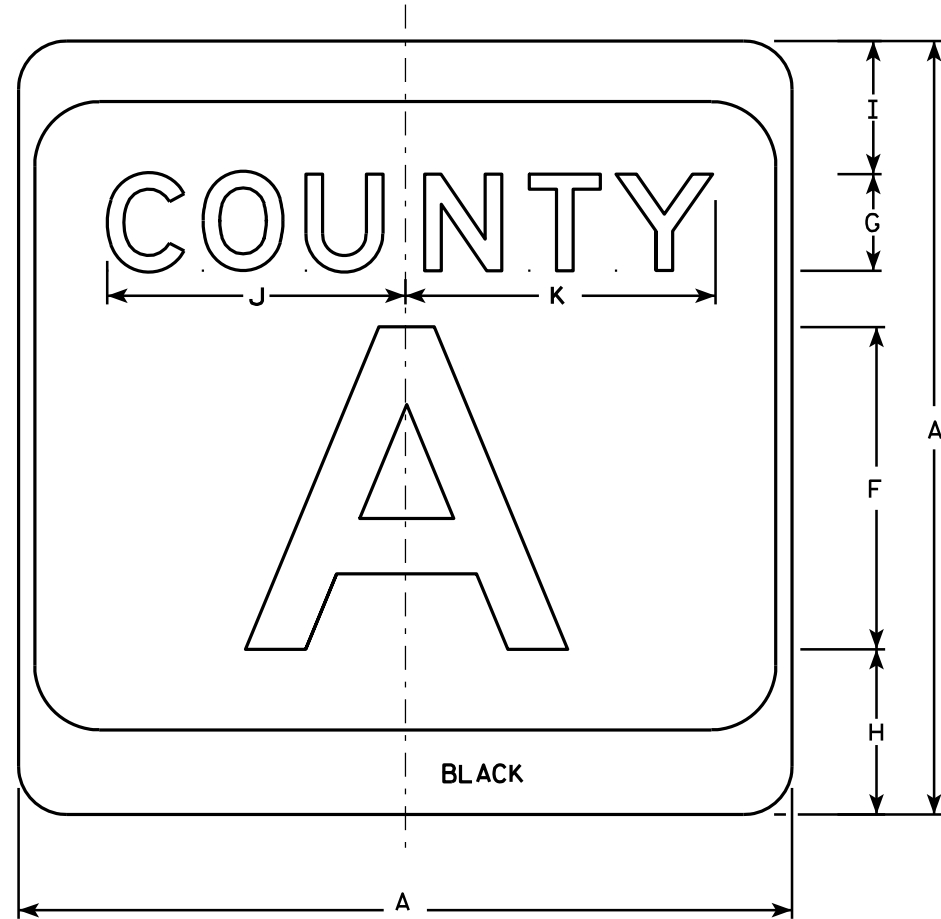

M1-5A

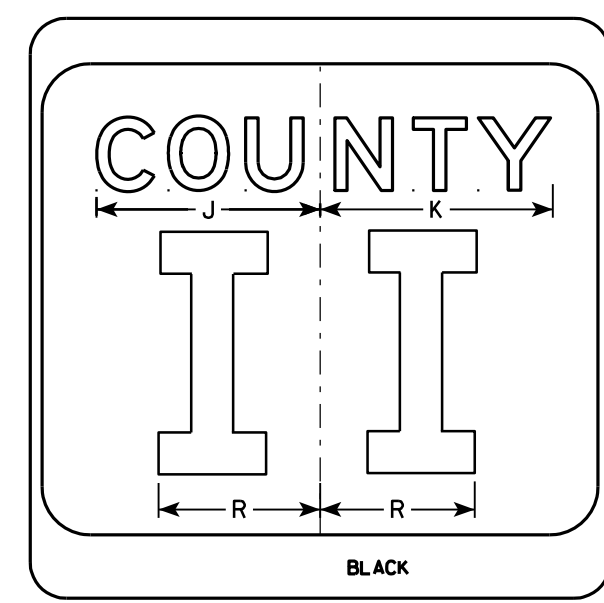
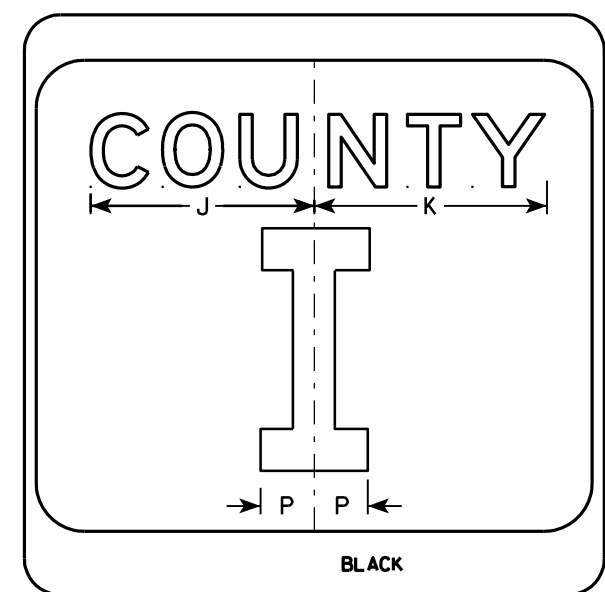
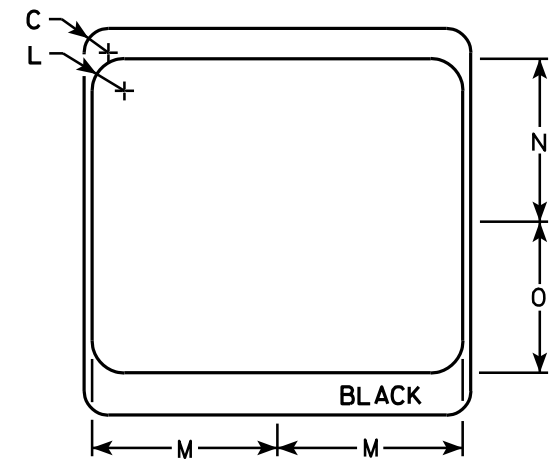

7

7

SIZE	A	B	C	D	E	F	G	H	I	J	K	L	M	N	O	P	Q	R	S	T	U	V	W	X	Y	Z	Area sq. ft.
1																											
2	24		1 1/2			10	3	5 1/8	4 1/8	9 1/4	9 5/8	2	11 1/2	10 1/8	9 3/8	2 1/4		6 5/8									4.0
3	36		2 1/4			16	4	7 5/8	5 5/8	12 1/4	12 7/8	3	17 1/8	15 1/4	14	3 3/8		10									9.0
4	36		2 1/4			16	4	7 5/8	5 5/8	12 1/4	12 7/8	3	17 1/8	15 1/4	14	3 3/8		10									9.0
5	36		2 1/4			16	4	7 5/8	5 5/8	12 1/4	12 7/8	3	17 1/8	15 1/4	14	3 3/8		10									9.0

CTH MARKER
M1-5A FOR ASSEMBLIES

WISCONSIN DEPT OF TRANSPORTATION

APPROVED *Matthew R. Raub*
For State Traffic Engineer

DATE 9/27/11 PLATE NO. MI-5A.8

PROJECT NO: _____ HWY: _____ COUNTY: _____ SHEET NO: **E**

NOTES

1. Sign is Type II - Type H Reflective
2. Color:
Background - White
Message - Black
3. Message Series - D except 3 number signs Series C
4. Corners may be square or rounded when base material is plywood but borders shall be rounded as shown. When base material is metal, the corners and borders shall be rounded.

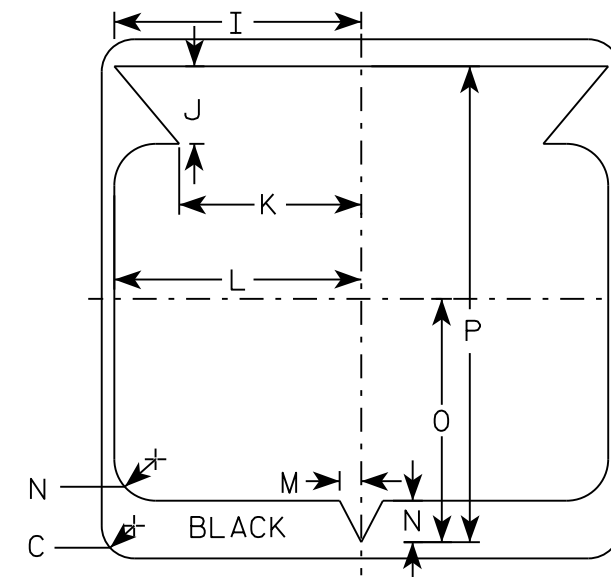
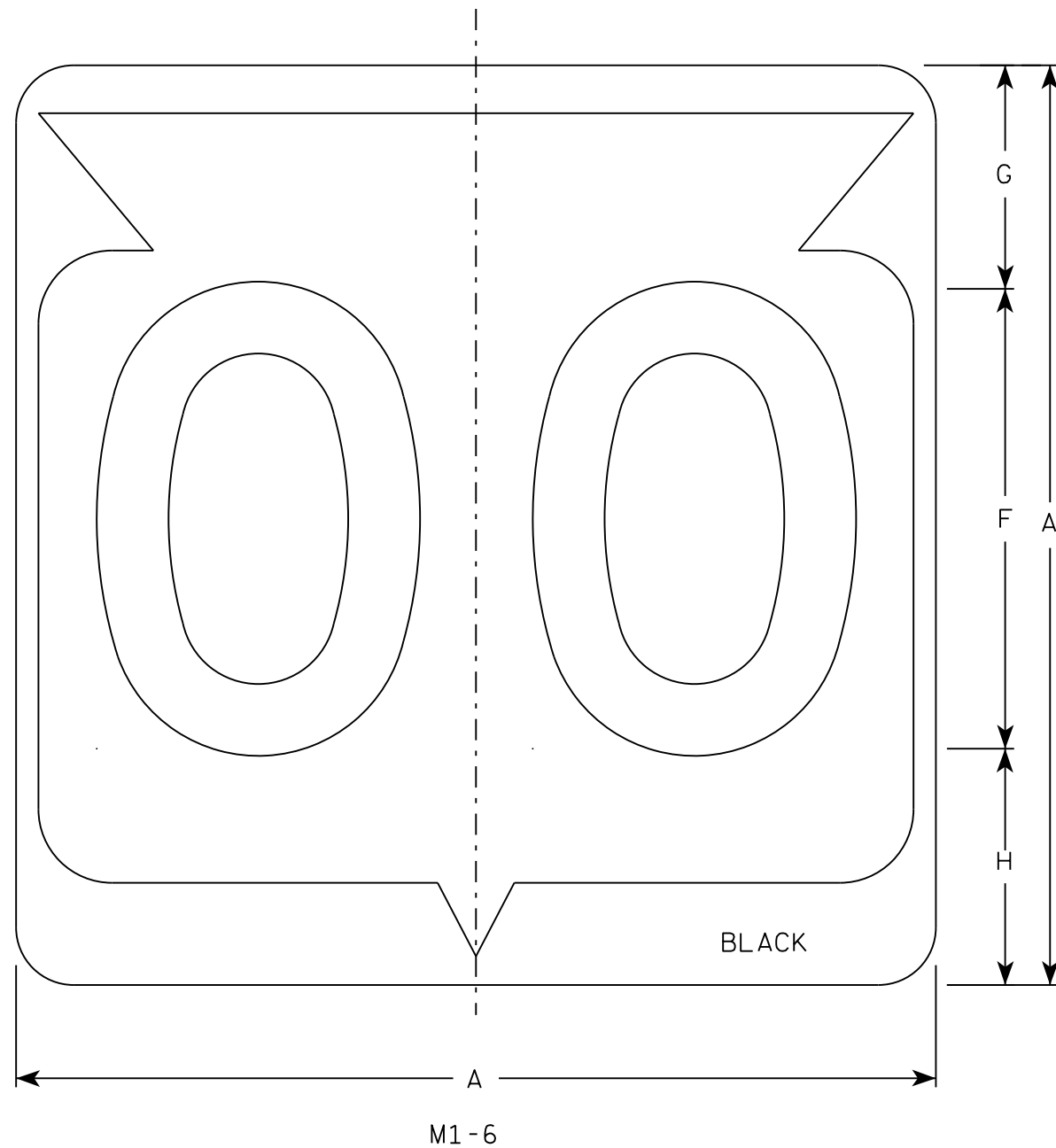

SIZE	A	B	C	D	E	F	G	H	I	J	K	L	M	N	O	P	Q	R	S	T	U	V	W	X	Y	Z	Area sq. ft.
1																											
2	24		1 1/2			12	5 1/2	6 1/2	10 1/4	2 1/2	8 7/8	11 1/2	1	1 7/8	11 1/4	21 7/8											4.0
3	36		2 1/4			18	8 3/4	9 1/4	15 3/8	5 3/8	12 5/8	17 1/8	1 1/2	2 7/8	16 7/8	33											9.0
4	36		2 1/4			18	8 3/4	9 1/4	15 3/8	5 3/8	12 5/8	17 1/8	1 1/2	2 7/8	16 7/8	33											9.0
5	36		2 1/4			18	8 3/4	9 1/4	15 3/8	5 3/8	12 5/8	17 1/8	1 1/2	2 7/8	16 7/8	33											9.0

STATE ROUTE MARKER
M1-6 FOR ASSEMBLIES

WISCONSIN DEPT OF TRANSPORTATION

APPROVED *Matthew R. Rauch*
for State Traffic Engineer

DATE 3/16/18 PLATE NO. M1-6.10

PROJECT NO: _____ HWY: _____ COUNTY: _____ SHEET NO: **E**

7

7

NOTES

1. Sign is Type II - Type H
2. Color:
 - Background - See note 5
 - Message - See note 5
3. Message Series - C
4. Corners may be square or rounded when base material is plywood but borders shall be rounded as shown. When base material is metal, the corners and borders shall be rounded.
5. M2-1 Background - White
 Message - Black
 MB2-1 Background - Blue
 Message - White
 MK2-1 Background - Green
 Message - White
 MM2-1 Background - White
 Message - Green
 MN2-1 Background - Brown
 Message - White
 MP2-1 Background - White
 Message - Blue
 MR2-1 Background - Brown
 Message - Yellow

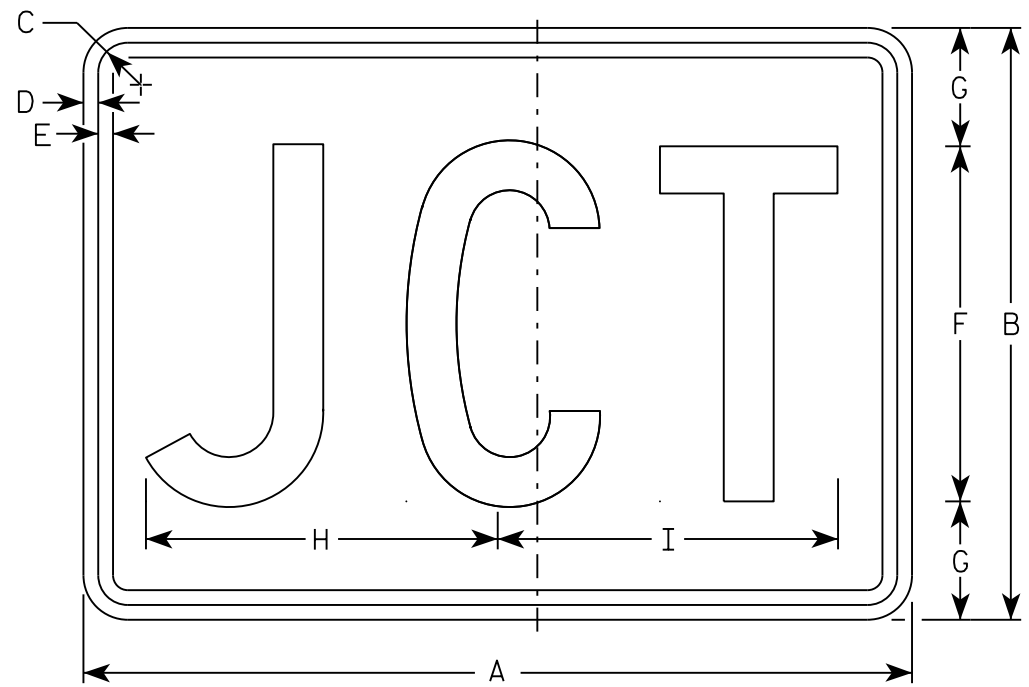

M2-1
MM2-1
MP2-1

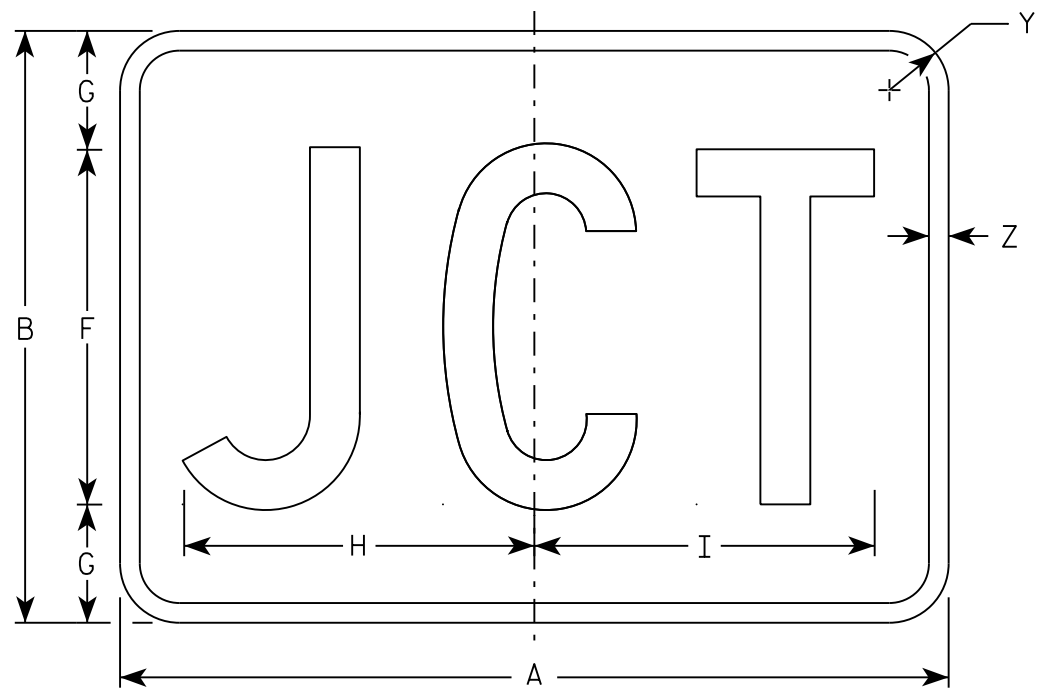

MB2-1
MK2-1
MN2-1
MR2-1

7

SIZE	A	B	C	D	E	F	G	H	I	J	K	L	M	N	O	P	Q	R	S	T	U	V	W	X	Y	Z	Area sq. ft.
1																											
2	21	15	1 1/8	3/8	3/8	9	3	8 7/8	8 5/8																1 1/2	1/2	2.20
3	30	21	1 1/8	3/8	3/8	13	4	12 7/8	12 3/8																1 1/2	1/2	4.40
4	30	21	1 1/8	3/8	3/8	13	4	12 7/8	12 3/8																1 1/2	1/2	4.40
5	30	21	1 1/8	3/8	3/8	13	4	12 7/8	12 3/8																1 1/2	1/2	4.40

STANDARD SIGN
M2-1

WISCONSIN DEPT OF TRANSPORTATION

APPROVED *Matthew R. Rauch*
For State Traffic Engineer

DATE 10/15/15 PLATE NO. M2-1.12

NOTES

1. Sign is Type II - Type F Reflective - reference WIS DOT Standard Specification for HIGHWAY and STRUCTURE CONSTRUCTION latest edition.
2. Color:
Background - Orange
Message - Black
3. Message Series - B
4. Corners may be square or rounded when base material is plywood but borders shall be rounded as shown. When base material is metal, the corners and borders shall be rounded.

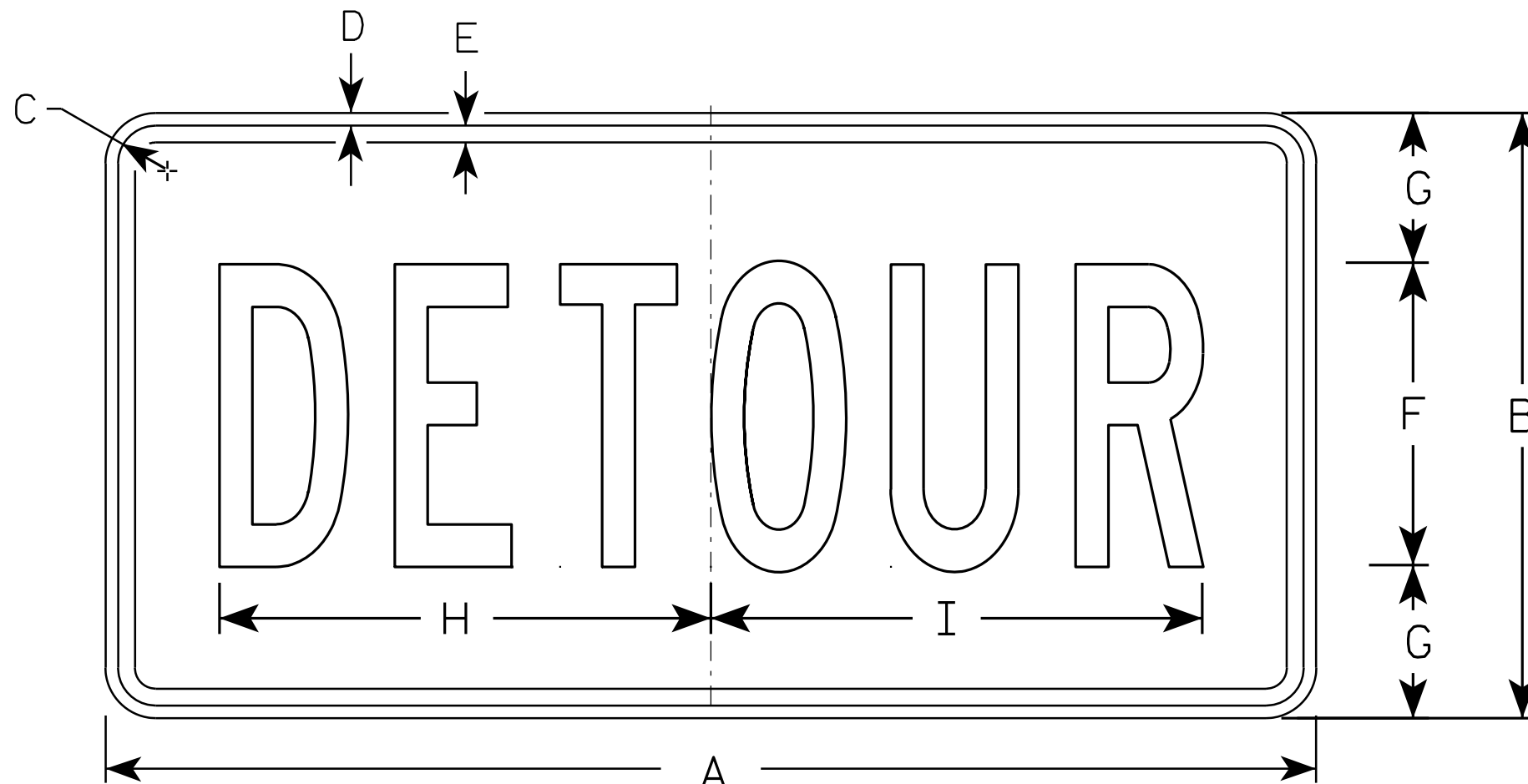

M4-8

7

7

SIZE	A	B	C	D	E	F	G	H	I	J	K	L	M	N	O	P	Q	R	S	T	U	V	W	X	Y	Z	Area sq. ft.
1																											
2	24	12	1 1/8	3/8	3/8	6	3	10	10 1/4																		2.0
3	36	18	1 1/8	3/8	1/2	9	4 1/2	14 5/8	14 1/2																		4.5
4																											
5																											

STANDARD SIGN
M4-8

WISCONSIN DEPT OF TRANSPORTATION

APPROVED *Matthew R. Rauch*
for State Traffic Engineer

DATE 11/10/10 PLATE NO. M4-8.2

PROJECT NO: _____ HWY: _____ COUNTY: _____ SHEET NO: **E**

NOTES

1. Sign is Type II - Type F Reflective - reference WIS DOT Standard Specification for HIGHWAY and STRUCTURE CONSTRUCTION latest edition.
2. Color:
Background - Orange
Message - Black
3. Message Series - B
4. Corners may be square or rounded when base material is plywood but borders shall be rounded as shown. When base material is metal, the corners and borders shall be rounded.

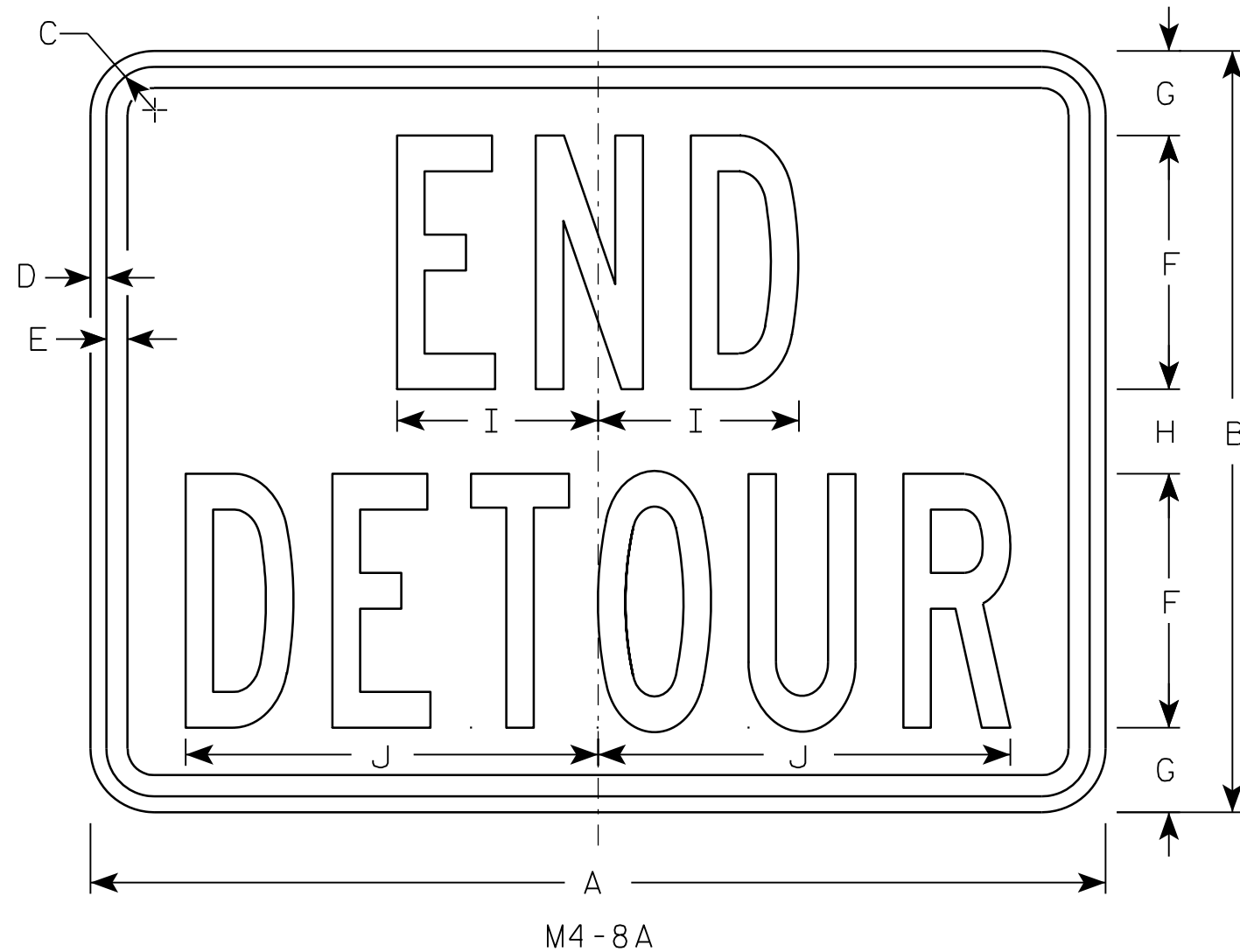

7

7

SIZE	A	B	C	D	E	F	G	H	I	J	K	L	M	N	O	P	Q	R	S	T	U	V	W	X	Y	Z	Area sq. ft.
1																											
2	24	18	1 1/8	3/8	1/2	6	2	2	4 3/4	9 3/4																	3.0
3	30	24	1 1/8	3/8	1/2	8	2 1/2	3	6 3/4	13																	5.0
4																											
5																											

STANDARD SIGN
M4-8A

WISCONSIN DEPT OF TRANSPORTATION

APPROVED *Matthew R. Rauch*
for State Traffic Engineer

DATE 3/9/11 PLATE NO. M4-8A.2

PROJECT NO: _____ HWY: _____ COUNTY: _____ SHEET NO: **E**

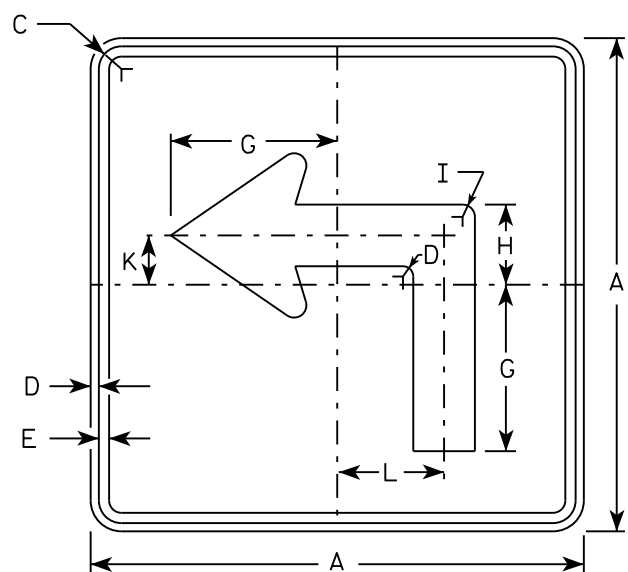

M5-1L
MM5-1L
M05-1L
MP5-1L

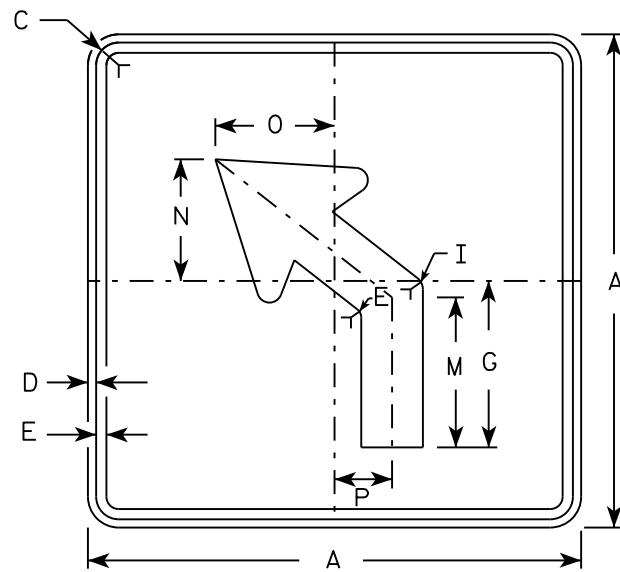

M5-2L
MM5-2L
M05-2L
MP5-2L

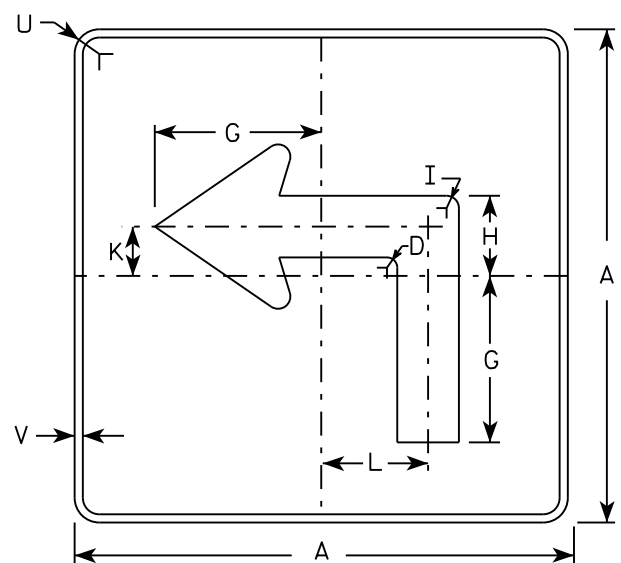

MB5-1L
MK5-1L
MN5-1L
MR5-1L

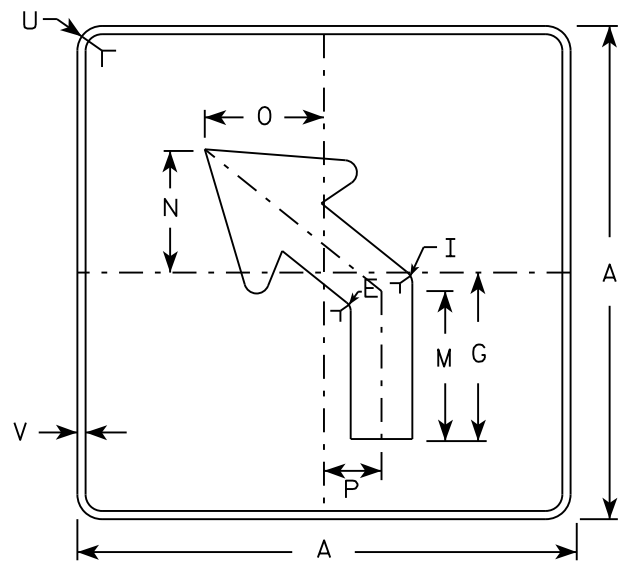

MB5-2L
MK5-2L
MN5-2L
MR5-2L

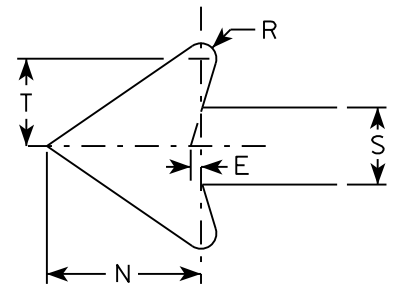

NOTES

- Signs are Type II - Type H reflective except as shown
- Color:
Background - See note 4
Message - See note 4
- Corners may be square or rounded when base material is plywood but borders shall be rounded as shown. When base material is metal, the corners and borders shall be rounded.
- | | |
|-----------------|---|
| M5-1 and M5-2 | Background - White |
| | Message - Black |
| MB5-1 and MB5-2 | Background - Blue |
| | Message - White |
| MK5-1 and MK5-2 | Background - Green |
| | Message - White |
| MM5-1 and MM5-2 | Background - White |
| | Message - Green |
| MN5-1 and MN5-2 | Background - Brown |
| | Message - White |
| M05-1 and M05-2 | Background - Orange - Type F Reflective |
| | Message - Black |
| MP5-1 and MP5-2 | Background - White - Type H Reflective |
| | Message - Blue |
| MR5-1 and MR5-2 | Background - Brown |
| | Message - Yellow |
- M5-1R same as M5-1L except arrow points right.
- M5-2R same as M5-2L except arrow tilts right.

SIZE	A	B	C	D	E	F	G	H	I	J	K	L	M	N	O	P	Q	R	S	T	U	V	W	X	Y	Z	Area sq. ft.
1																											
2	21		1 1/8	3/8	3/8		7	3 3/8	5/8		2 1/8	4 1/2	6 3/8	5 1/4	5	2 1/2		1/2	2 5/8	3	1 1/2	1/2					3.06
3	30		1 3/8	1/2	5/8		10 1/8	4 7/8	7/8		3	6 1/2	9 1/8	7 1/2	7 1/4	3 1/2		3/4	3 3/4	4 1/4	1 7/8	1/2					6.25
4	30		1 3/8	1/2	5/8		10 1/8	4 7/8	7/8		3	6 1/2	9 1/8	7 1/2	7 1/4	3 1/2		3/4	3 3/4	4 1/4	1 7/8	1/2					6.25
5	30		1 3/8	1/2	5/8		10 1/8	4 7/8	7/8		3	6 1/2	9 1/8	7 1/2	7 1/4	3 1/2		3/4	3 3/4	4 1/4	1 7/8	1/2					6.25

STANDARD SIGN
M5-1 & M5-2

WISCONSIN DEPT OF TRANSPORTATION

APPROVED *Matthew R. Rauch*
for State Traffic Engineer

DATE 10/15/15 PLATE NO. M5-1.13

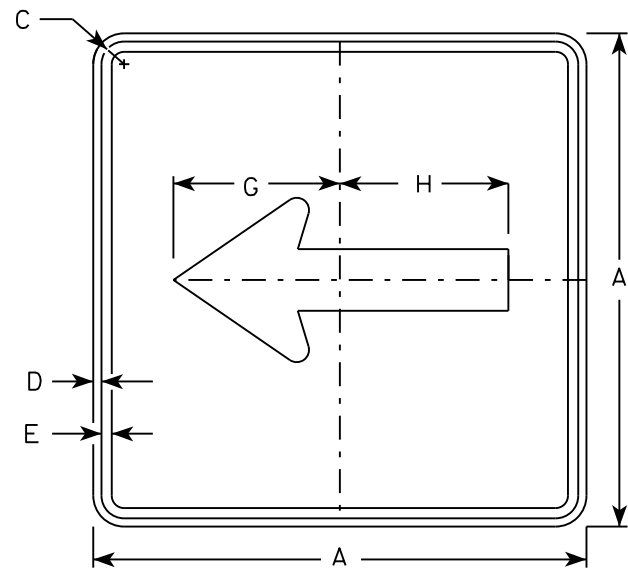

M6-1
MM6-1
M06-1
MP6-1

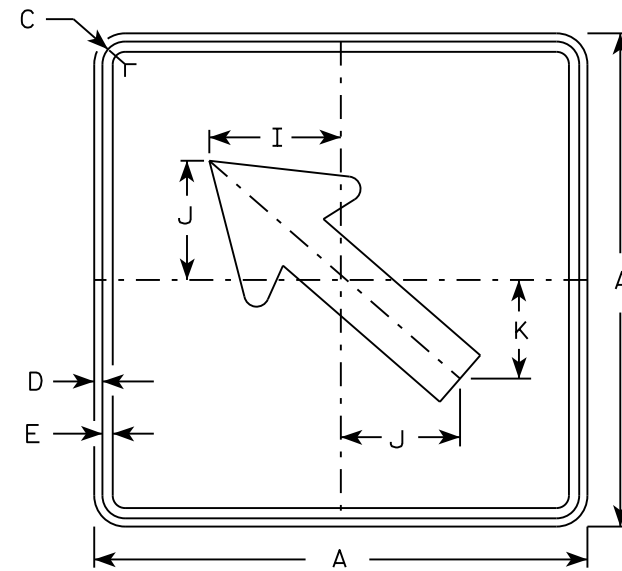

M6-2
MM6-2
M06-2
MP6-2

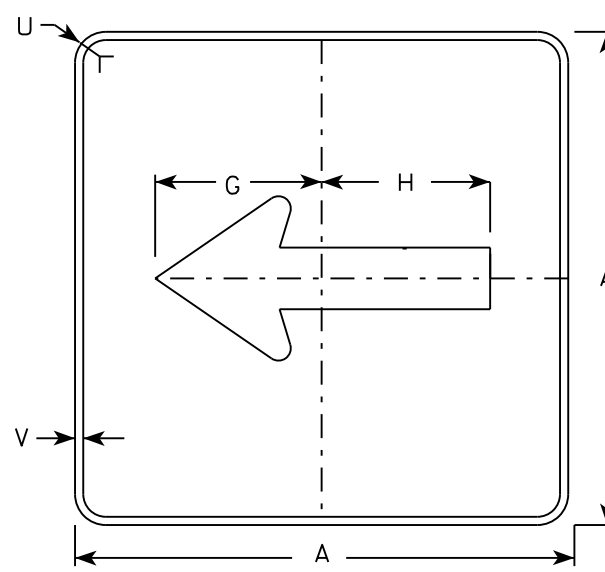

MB6-1
MK6-1
MN6-1
MR6-1

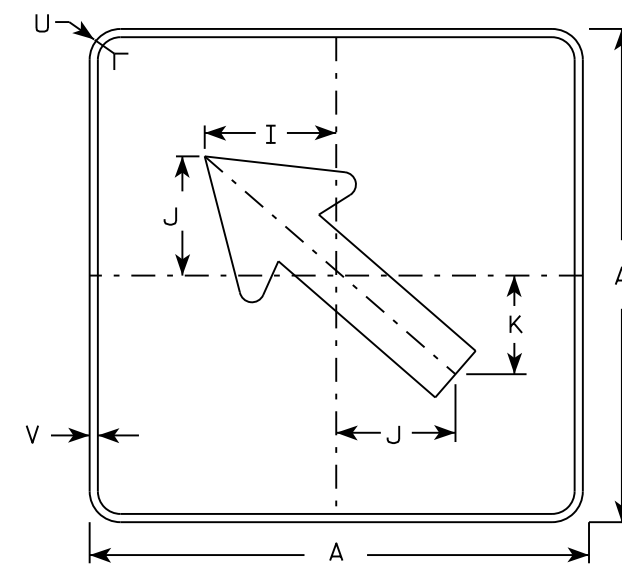

MB6-2
MK6-2
MN6-2
MR6-2

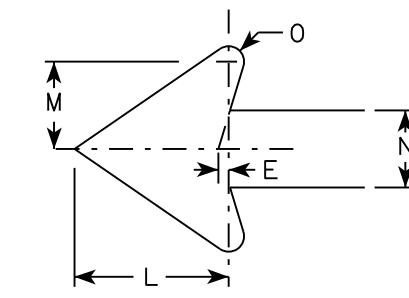

NOTES

- Signs are Type II - Type H except as Shown
- Color:
Background - See note 4
Message - See note 4
- Corners may be square or rounded when base material is plywood but borders shall be rounded as shown. When base material is metal, the corners and borders shall be rounded.
- M6-1 and M6-2 Background - White
Message - Black
MB6-1 and MB6-2 Background - Blue
Message - White
MK6-1 and MK6-2 Background - Green
Message - White
MM6-1 and MM6-2 Background - White
Message - Green
MN6-1 and MN6-2 Background - Brown
Message - White
M06-1 and M06-2 Background - Orange - Type F Reflective
Message - Black
MP6-1 and MP6-2 Background - White
Message - Blue
MR6-1 and MR6-2 Background - Brown
Message - Yellow

7

SIZE	A	B	C	D	E	F	G	H	I	J	K	L	M	N	O	P	Q	R	S	T	U	V	W	X	Y	Z	Area sq. ft.
1																											
2	21		1 1/8	3/8	3/8		7 1/2	7 1/8	5 5/8	5	4 1/4	5 1/4	3	2 5/8	1/2						1 1/2	1/2					3.06
3	30		1 3/8	1/2	5/8		10 3/4	10 1/4	8	7 1/4	6	7 1/2	4 1/4	3 3/4	3/4						1 7/8	1/2					6.25
4	30		1 3/8	1/2	5/8		10 3/4	10 1/4	8	7 1/4	6	7 1/2	4 1/4	3 3/4	3/4						1 7/8	1/2					6.25
5	30		1 3/8	1/2	5/8		10 3/4	10 1/4	8	7 1/4	6	7 1/2	4 1/4	3 3/4	3/4						1 7/8	1/2					6.25

STANDARD SIGN
M6-1 & M6-2
SERIES

WISCONSIN DEPT OF TRANSPORTATION

APPROVED *Matthew R. Rauch*
for State Traffic Engineer

DATE 10/15/15 PLATE NO. M6-1.15

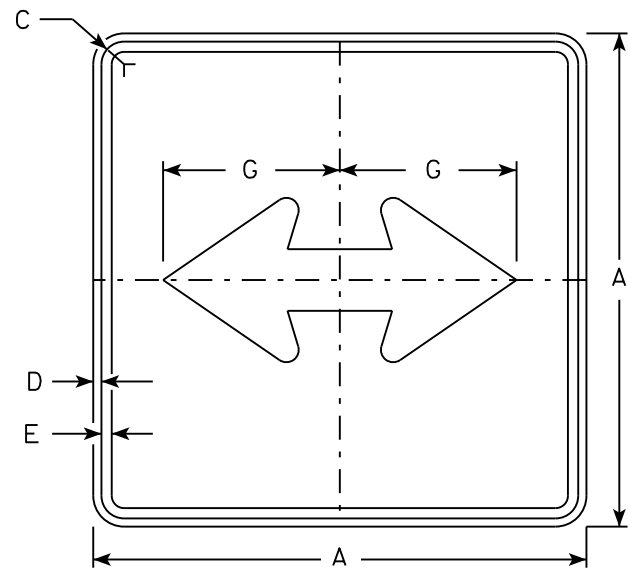

M6-4
MM6-4
M06-4
MP6-4

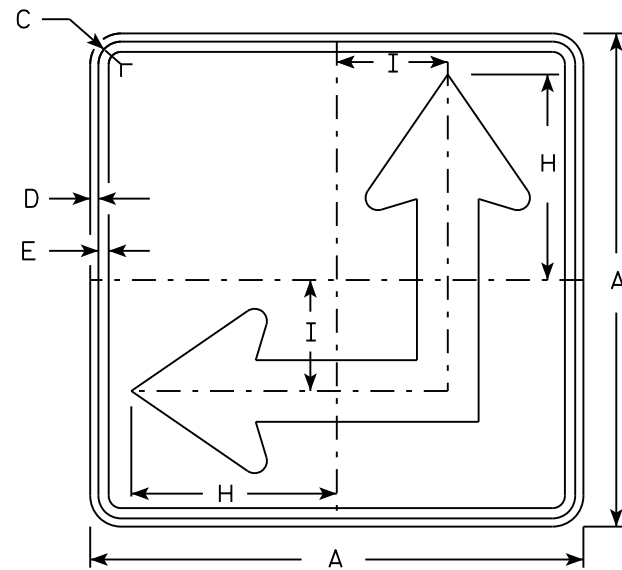

M6-6
MM6-6
M06-6
MP6-6

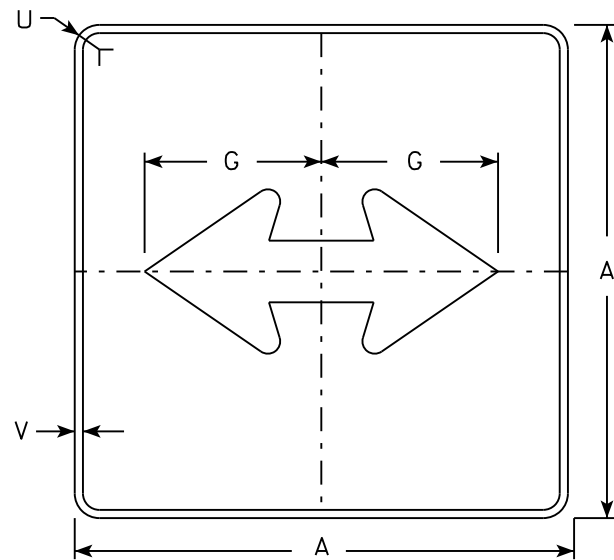

MB6-4
MK6-4
MN6-4
MR6-4

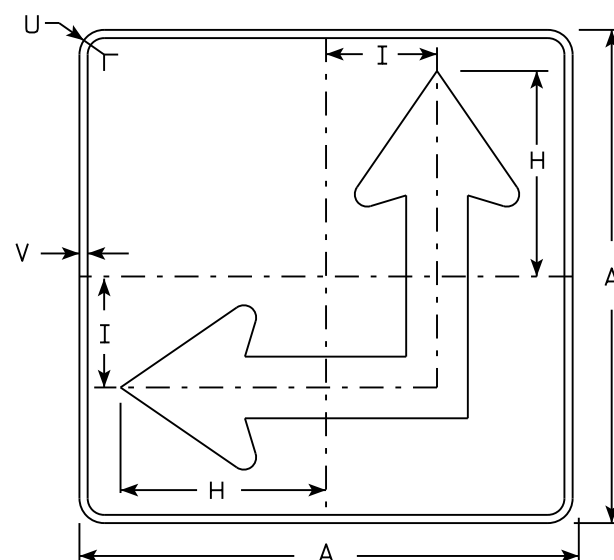

MB6-6
MK6-6
MN6-6
MR6-6

NOTES

- Signs are Type II - Type H except as Shown
- Color:
Background - See Note 4
Message - See Note 4
- Corners may be square or rounded when base material is plywood but borders shall be rounded as shown. When base material is metal, the corners and borders shall be rounded.
- M6-4 and M6-6 Background - White
Message - Black
MB6-4 and MB6-6 Background - Blue
Message - White
MK6-4 and MK6-6 Background - Green
Message - White
MM6-4 and MM6-6 Background - White
Message - Green
MN6-4 and MN6-6 Background - Brown
Message - White
M06-4 and M06-6 Background - Orange - Type F Reflective
Message - Black
MP6-4 and MP6-6 Background - White
Message - Blue
MR6-4 and MR6-6 Background - Brown
Message - Yellow
- M6-6R same as M6-6L except arrow points ahead and right.

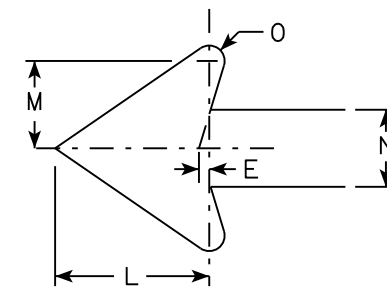

7

SIZE	A	B	C	D	E	F	G	H	I	J	K	L	M	N	O	P	Q	R	S	T	U	V	W	X	Y	Z	Area sq. ft.
1																											
2	21		1 1/8	3/8	3/8		7 1/2	8 3/4	4 1/4			5 1/4	3	2 5/8	1/2						1 1/2	1/2					3.06
3	30		1 3/8	1/2	5/8		10 3/4	12 1/2	6 3/4			7 1/2	4 1/4	3 3/4	3/4						1 7/8	1/2					6.25
4	30		1 3/8	1/2	5/8		10 3/4	12 1/2	6 3/4			7 1/2	4 1/4	3 3/4	3/4						1 7/8	1/2					6.25
5	30		1 3/8	1/2	5/8		10 3/4	12 1/2	6 3/4			7 1/2	4 1/4	3 3/4	3/4						1 7/8	1/2					6.25

STANDARD SIGN
M6-4 & M6-6
SERIES

WISCONSIN DEPT OF TRANSPORTATION

APPROVED *Matthew R. Rauch*
for State Traffic Engineer

DATE 10/15/15 PLATE NO. M6-4.10

NOTES

1. Sign is Type II - Type H Reflective - reference WIS DOT Standard Specification for HIGHWAY and STRUCTURE CONSTRUCTION latest edition.
2. Color:
Background - Red
Message - White
3. Message Series - C

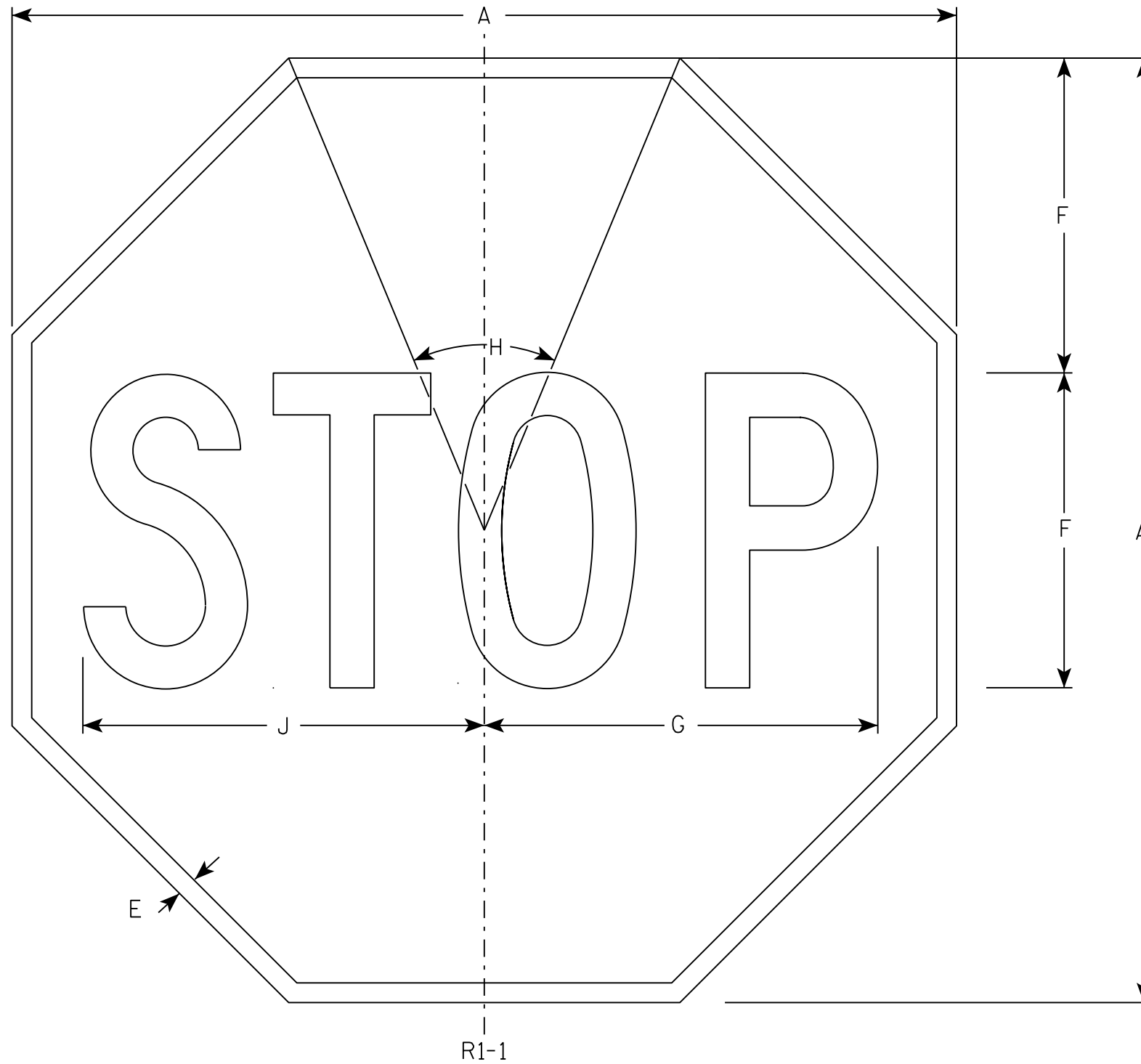

7

7

SIZE	A	B	C	D	E	F	G	H	I	J	K	L	M	N	O	P	Q	R	S	T	U	V	W	X	Y	Z	Area sq. ft.
1	30				5/8	10	12 1/2	45°		12 3/4																	5.18
2S	30				5/8	10	12 1/2	45°		12 3/4																	5.18
2M	36				3/4	12	15	45°		15 3/8																	7.46
3	36				3/4	12	15	45°		15 3/8																	7.46
4	48				1	16	20	45°		20 1/2																	13.25
5	48				1	16	20	45°		20 1/2																	13.25
6	18				3/8	6	7 3/4	45°		7 3/4																	1.86
7	12				1/4	4	5	45°		5 1/8																	0.78

PROJECT NO: _____ HWY: _____ COUNTY: _____ SHEET NO: _____ **E**

STANDARD SIGN
R1-1

WISCONSIN DEPT OF TRANSPORTATION

APPROVED *Matthew R. Rauch*
for State Traffic Engineer

DATE 11/12/15 PLATE NO. R1-1.13

NOTES

1. Sign is Type II - Type H Reflective - reference WIS DOT Standard Specification for HIGHWAY and STRUCTURE CONSTRUCTION latest edition.
2. Color:
Background - White
Message - Black
3. Message Series - C
4. Corners may be square or rounded when base material is plywood but borders shall be rounded as shown. When base material is metal, the corners and borders shall be rounded.

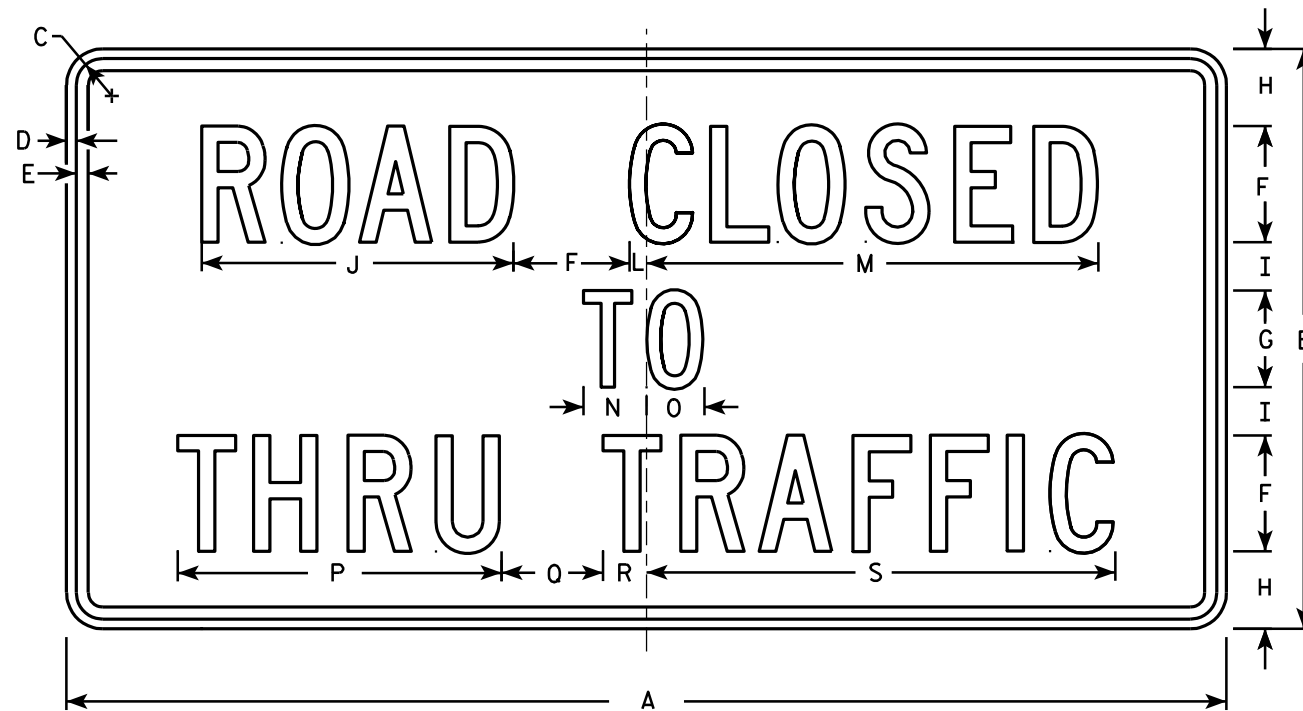

R11-4

7

7

SIZE	A	B	C	D	E	F	G	H	I	J	K	L	M	N	O	P	Q	R	S	T	U	V	W	X	Y	Z	Area sq. ft.
1																											
2S	60	30	1 3/8	1/2	5/8	6	5	4	2 1/2	16 1/8		7/8	23 3/8	3 1/4	3	16 3/4	5 1/4	2 1/4	24 1/4								12.5
2M	60	30	1 3/8	1/2	5/8	6	5	4	2 1/2	16 1/8		7/8	23 3/8	3 1/4	3	16 3/4	5 1/4	2 1/4	24 1/4								12.5
3																											
4																											
5																											

STANDARD SIGN
R11 - 4

WISCONSIN DEPT OF TRANSPORTATION

APPROVED *Matthew R. Raush*
for State Traffic Engineer

DATE 4/1/11 PLATE NO. R11-4.3

PROJECT NO: _____ HWY: _____ COUNTY: _____ SHEET NO: _____ E

NOTES

1. Sign is Type II - Type F Reflective - reference WIS DOT Standard Specification for HIGHWAY and STRUCTURE CONSTRUCTION latest edition.
2. Color:
Background - Yellow
Message - Black
3. Corners may be square or rounded when base material is plywood but borders shall be rounded as shown. When base material is metal, the corners and borders shall be rounded.
4. W1-1L is the same as W1-1R except the arrow is reversed along the vertical centerline.

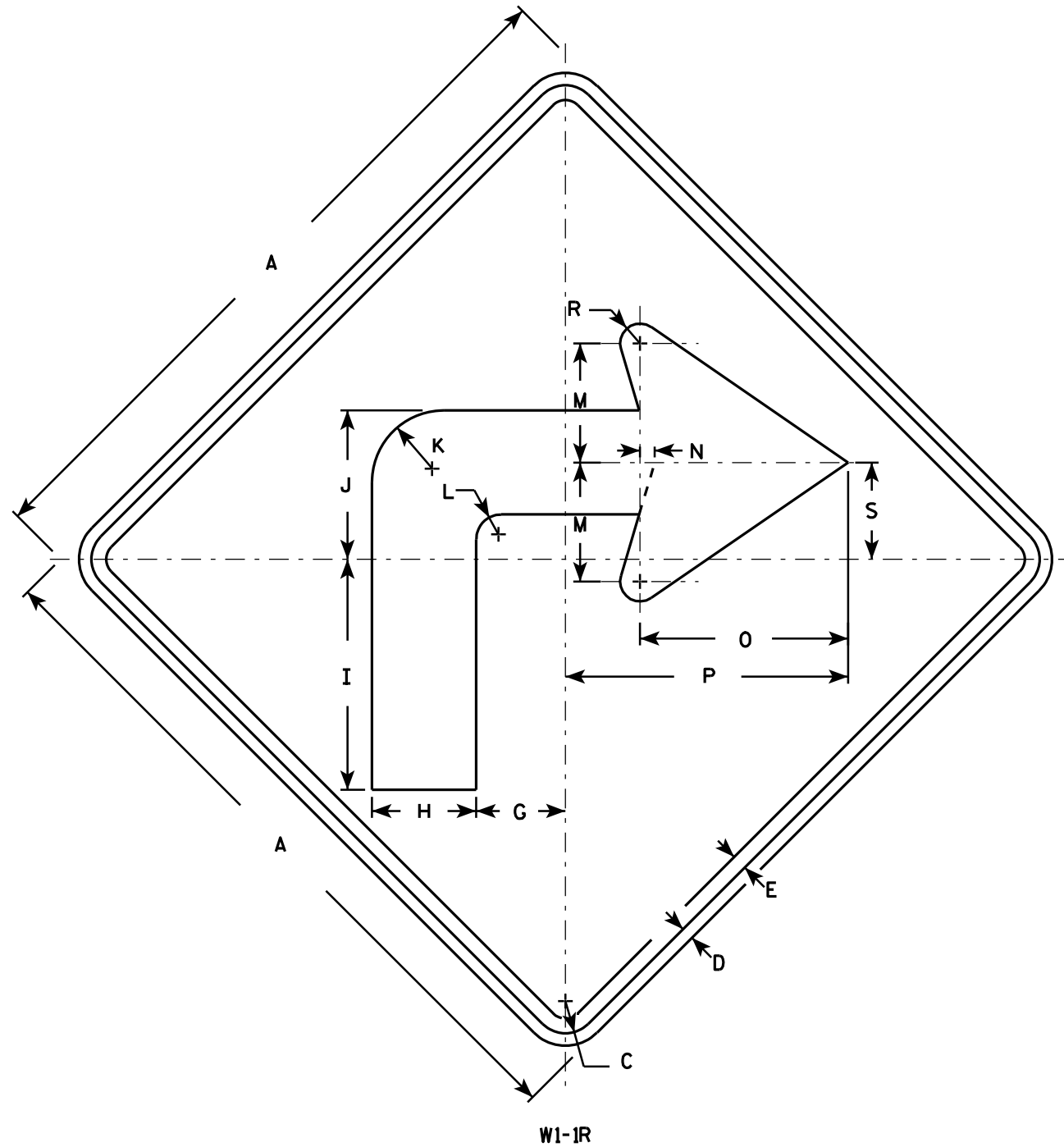

7

7

SIZE	A	B	C	D	E	F	G	H	I	J	K	L	M	N	O	P	Q	R	S	T	U	V	W	X	Y	Z	Area sq. ft.
1	24		1 1/8	3/8	1/2		3	3 1/2	7 3/4	5	2 1/2	7/8	4	1/2	7	9 1/2		5/8	3 1/4								4.0
2S	36		1 5/8	5/8	3/4		4 1/2	5 1/4	11 5/8	7 1/2	3 5/8	1 1/4	6	3/4	10 1/2	14 1/4		1	4 7/8								9.0
2M	36		1 5/8	5/8	3/4		4 1/2	5 1/4	11 5/8	7 1/2	3 5/8	1 1/4	6	3/4	10 1/2	14 1/4		1	4 7/8								9.0
3	36		1 5/8	5/8	3/4		4 1/2	5 1/4	11 5/8	7 1/2	3 5/8	1 1/4	6	3/4	10 1/2	14 1/4		1	4 7/8								9.0
4	48		2 1/4	3/4	1		6	7	15 1/2	10	4 7/8	1 5/8	8	1	14	19		1 1/4	6 1/2							16.0	
5	48		2 1/4	3/4	1		6	7	15 1/2	10	4 7/8	1 5/8	8	1	14	19		1 1/4	6 1/2							16.0	

STANDARD SIGN
W1-1

WISCONSIN DEPT OF TRANSPORTATION

APPROVED *Matthew R. Rauch*
for State Traffic Engineer

DATE 5/15/12 PLATE NO. W1-1.11

PROJECT NO: _____ HWY: _____ COUNTY: _____ SHEET NO: _____ E

NOTES

1. Sign is Type II - Type F Reflective - reference WIS DOT Standard Specification for HIGHWAY and STRUCTURE CONSTRUCTION latest edition.
2. Color:
Background - Yellow
Message - Black
3. Corners may be square or rounded when base material is plywood but borders shall be rounded as shown. When base material is metal, the corners and borders shall be rounded.

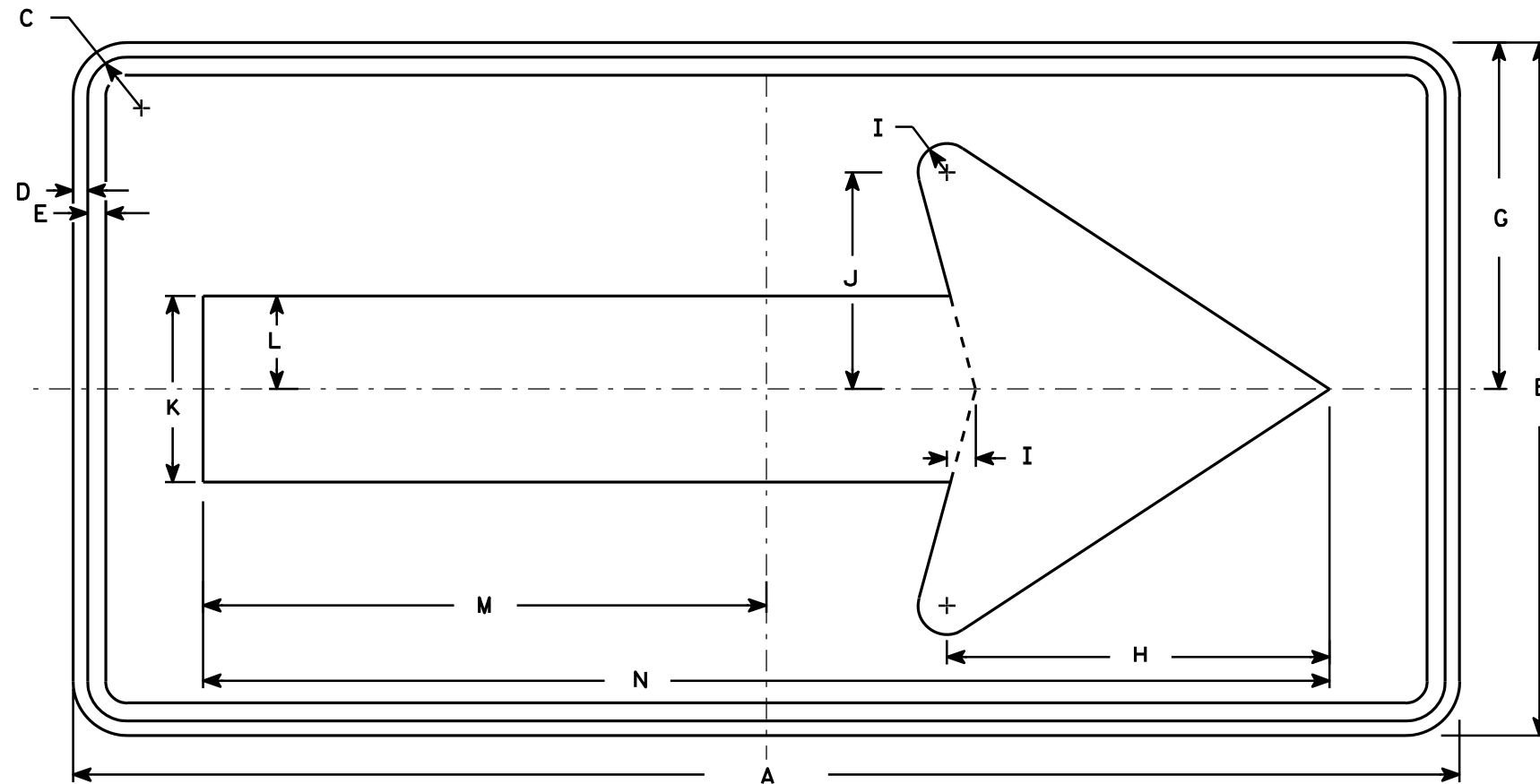

W1-6

7

7

SIZE	A	B	C	D	E	F	G	H	I	J	K	L	M	N	O	P	Q	R	S	T	U	V	W	X	Y	Z	Area sq. ft.
1	36	18	1 1/8	3/8	3/8		9	10	3/4	5 5/8	4 3/4	2 3/8	14 5/8	29 1/4													4.5
2S	48	24	1 3/8	1/2	5/8		12	13 1/4	1	7 1/2	6 1/2	3 1/4	19 1/2	39													8.0
2M	48	24	1 3/8	1/2	5/8		12	13 1/4	1	7 1/2	6 1/2	3 1/4	19 1/2	39													8.0
3	60	30	1 3/8	1/2	5/8		15	16 1/4	1 1/4	9 1/4	8	4	24 3/8	48 3/4													12.5
4	60	30	1 3/8	1/2	5/8		15	16 1/4	1 1/4	9 1/4	8	4	24 3/8	48 3/4													12.5
5	96	48	2 1/4	3/4	1		24	26 1/2	2	15	13	6 1/2	39	78													32.0

STANDARD SIGN
W1-6

WISCONSIN DEPT OF TRANSPORTATION

APPROVED *Matthew R. Rauch*
For State Traffic Engineer

DATE 6/7/10 PLATE NO. W1-6.8

PROJECT NO: _____ HWY: _____ COUNTY: _____ SHEET NO: _____

NOTES

1. Sign is Type II - Type F Reflective - reference WIS DOT Standard Specification for HIGHWAY and STRUCTURE CONSTRUCTION latest edition.
2. Color:
Background - Yellow
Message - Black
3. Corners may be square or rounded when base material is plywood but borders shall be rounded as shown. When base material is metal, the corners and borders shall be rounded.

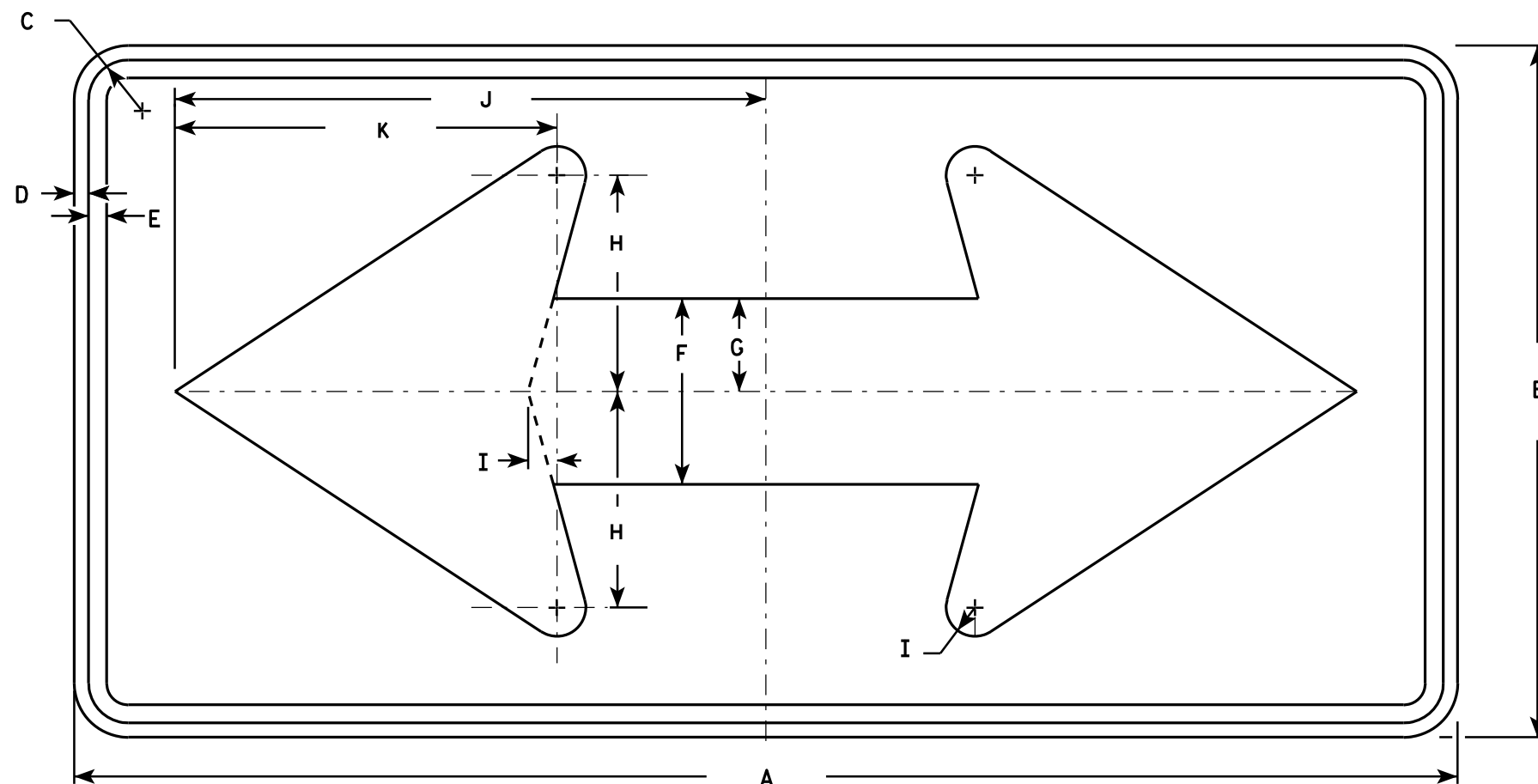

W1-7

7

7

SIZE	A	B	C	D	E	F	G	H	I	J	K	L	M	N	O	P	Q	R	S	T	U	V	W	X	Y	Z	Area sq. ft.
1	36	18	1 1/8	3/8	1/2	5	2 1/2	5 3/4	3/4	15 5/8	10 1/8																4.5
2S	48	24	1 3/8	1/2	5/8	6 1/2	3 1/4	7 1/2	1	20 1/2	13 1/4																8.0
2M	48	24	1 3/8	1/2	5/8	6 1/2	3 1/4	7 1/2	1	20 1/2	13 1/4																8.0
3	60	30	1 3/8	1/2	5/8	8	4	9 1/4	1 1/4	25 3/8	16 1/4																12.5
4	60	30	1 3/8	1/2	5/8	8	4	9 1/4	1 1/4	25 3/8	16 1/4																12.5
5	96	48	2 1/4	3/4	1	13	6 1/2	15	2	41	26 1/2																32.0

STANDARD SIGN
W1-7

WISCONSIN DEPT OF TRANSPORTATION

APPROVED *Matthew R. Rauch*
For State Traffic Engineer

DATE 6/7/10 PLATE NO. W1-7.7

PROJECT NO: _____ HWY: _____ COUNTY: _____ SHEET NO: _____ E

NOTES

1. Sign is Type II - Type F Reflective - reference WIS DOT Standard Specification for HIGHWAY and STRUCTURE CONSTRUCTION latest edition.
2. Color:
Background - Yellow
Message - Black
3. Corners may be square or rounded when base material is plywood but borders shall be rounded as shown. When base material is metal, the corners and borders shall be rounded.
4. W1-10L is the same as W1-10R except the arrow is reversed along the vertical centerline.

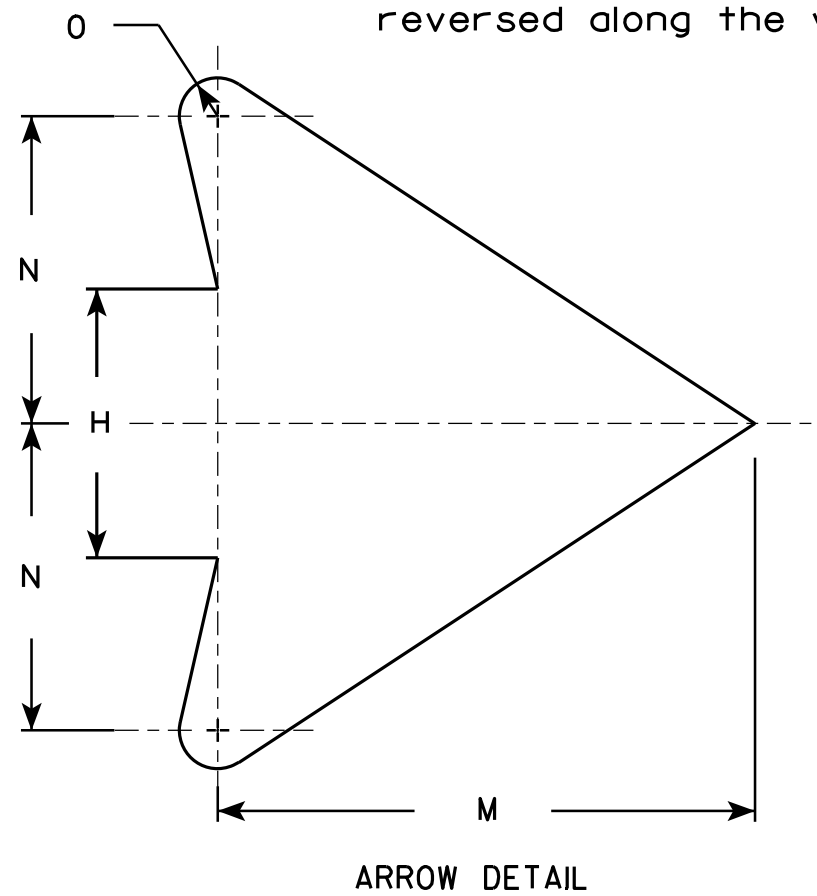
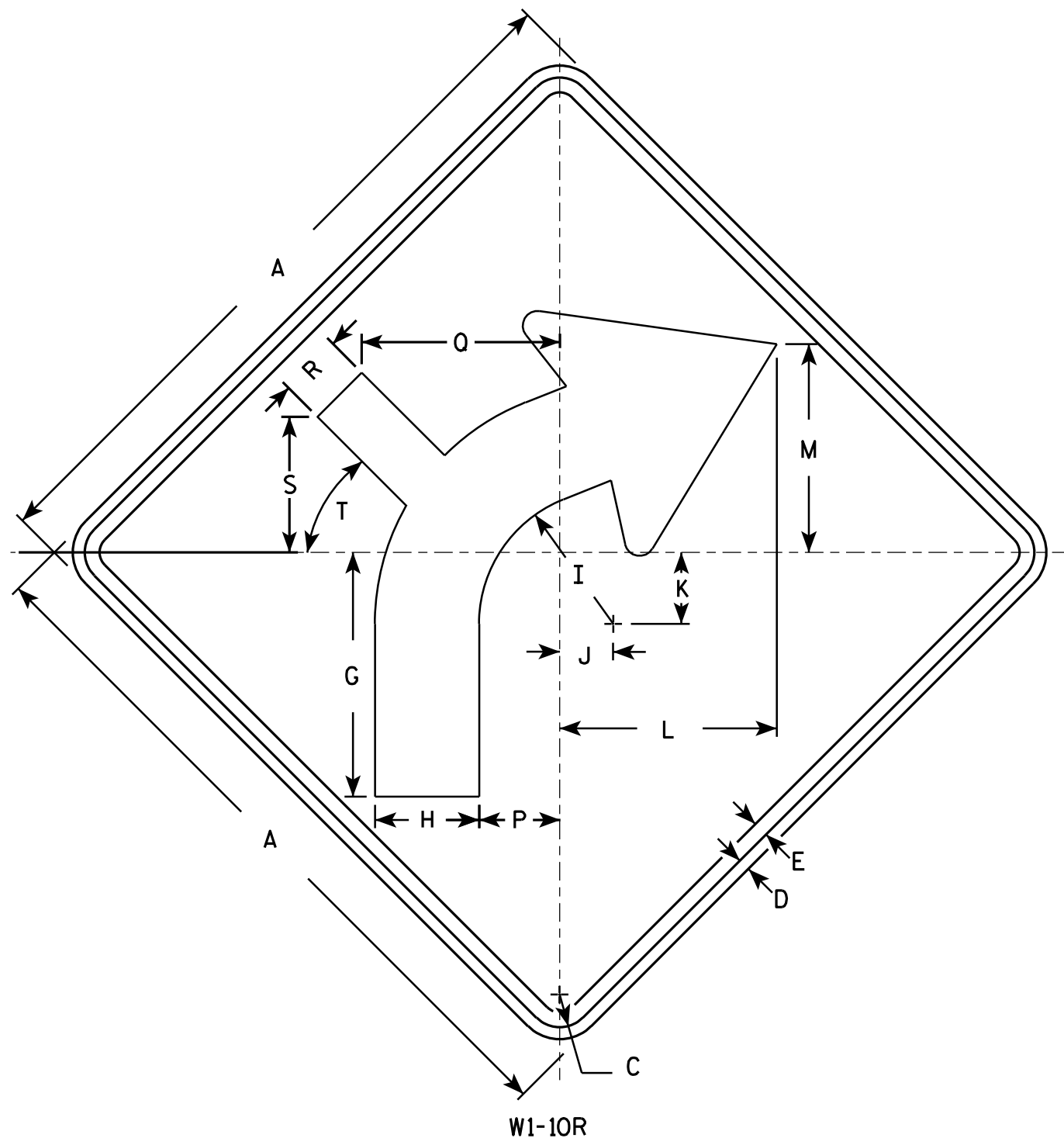

7

7

SIZE	A	B	C	D	E	F	G	H	I	J	K	L	M	N	O	P	Q	R	S	T	U	V	W	X	Y	Z	Area sq. ft.
1	24		1 1/8	3/8	1/2		8 1/4	3 1/2	4 1/2	1 3/4	2 3/8	7 1/4	7	4	1/2	2 5/8	6 5/8	2 1/8	4 1/2	45°							4.0
2S	30		1 3/8	1/2	5/8		10 1/4	4 3/8	5 5/8	2 1/4	3	9 1/8	8 3/4	5	5/8	3 3/8	8 3/8	2 5/8	5 3/4	45°							6.25
2M	36		1 5/8	5/8	3/4		12 3/8	5 1/4	6 3/4	2 5/8	3 1/2	10 7/8	10 1/2	6	3/4	4	10	3 1/4	6 7/8	45°							9.0
3	36		1 5/8	5/8	3/4		12 3/8	5 1/4	6 3/4	2 5/8	3 1/2	10 7/8	10 1/2	6	3/4	4	10	3 1/4	6 7/8	45°							9.0
4	36		1 5/8	5/8	3/4		12 3/8	5 1/4	6 3/4	2 5/8	3 1/2	10 7/8	10 1/2	6	3/4	4	10	3 1/4	6 7/8	45°							9.0
5	48		2 1/4	3/4	1		16 1/2	7	9	3 1/2	4 5/8	14 1/2	14	8	1	5 3/8	13 1/4	4 1/4	9 1/8	45°							16.0

STANDARD SIGN
W1-10

WISCONSIN DEPT OF TRANSPORTATION

APPROVED *Matthew R. Rauch*
for State Traffic Engineer

DATE 5/17/12 PLATE NO. W1-10.3

PROJECT NO: _____ HWY: _____ COUNTY: _____ SHEET NO: _____ E

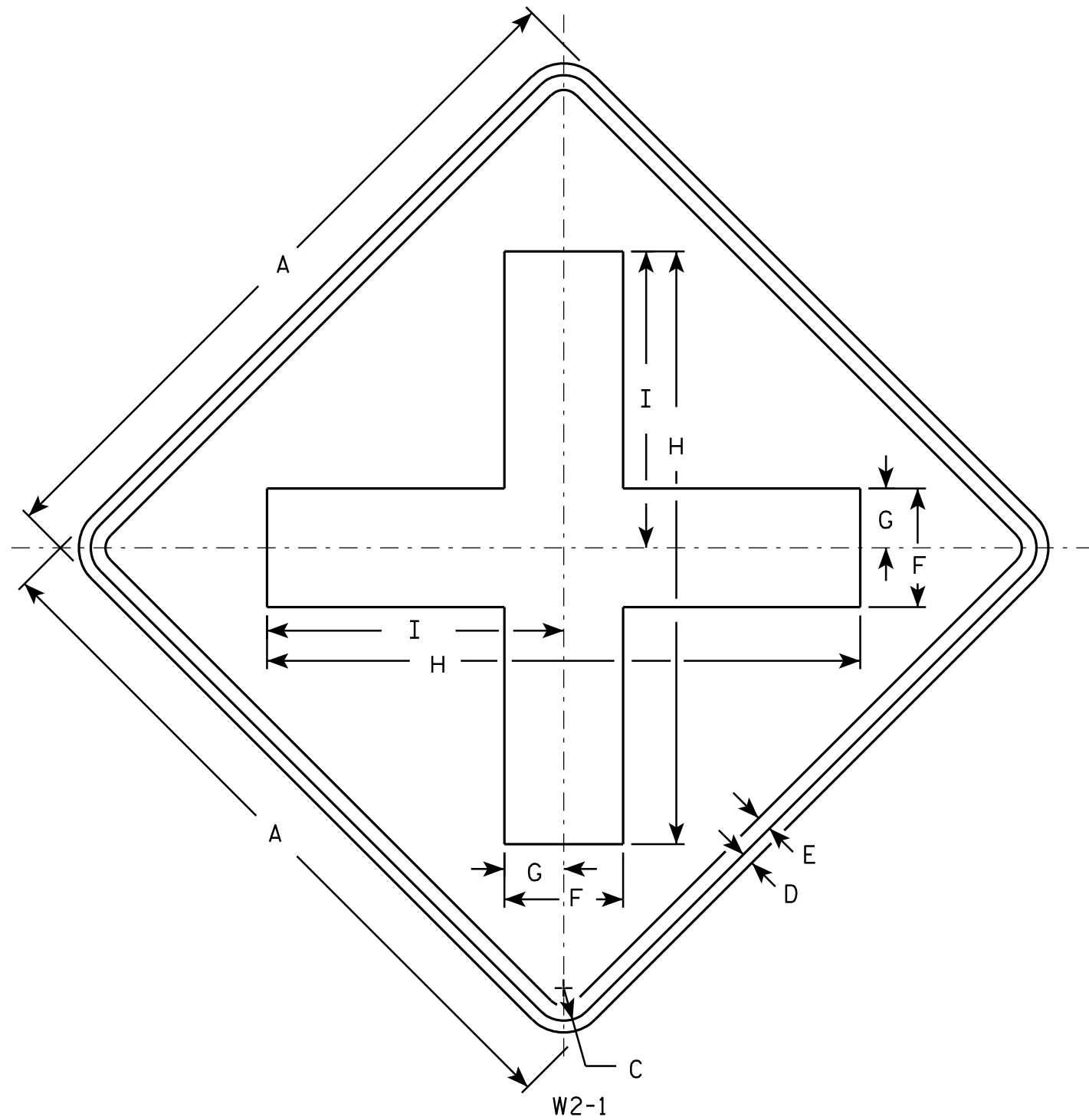

NOTES

1. Sign is Type II - Type F Reflective - reference WIS DOT Standard Specification for HIGHWAY and STRUCTURE CONSTRUCTION latest edition.
2. Color:
Background - Yellow
Message - Black
3. Corners may be square or rounded when base material is plywood but borders shall be rounded as shown. When base material is metal, the corners and borders shall be rounded.

7

7

SIZE	A	B	C	D	E	F	G	H	I	J	K	L	M	N	O	P	Q	R	S	T	U	V	W	X	Y	Z	Area sq. ft.
1	24		1 1/8	3/8	1/2	4	2	20	10																		4.0
2S	30		1 3/8	1/2	5/8	5	2 1/2	25	12 1/2																		6.25
2M	30		1 3/8	1/2	5/8	5	2 1/2	25	12 1/2																		6.25
3	36		1 5/8	5/8	3/4	6	3	30	15																		9.0
4	48		2 1/4	3/4	1	8	4	40	20																		16.0
5																											

STANDARD SIGN
W2-1

WISCONSIN DEPT OF TRANSPORTATION

APPROVED *Matthew R. Rauch*
for State Traffic Engineer

DATE 5/29/12 PLATE NO. W2-1.9

PROJECT NO: _____ HWY: _____ COUNTY: _____ SHEET NO: _____ E

NOTES

1. Sign is Type II - Type F Reflective
2. Color:
Background - Yellow
Message - Black
3. W2-2L same as W2-2R but is rotated 180° when mounted.

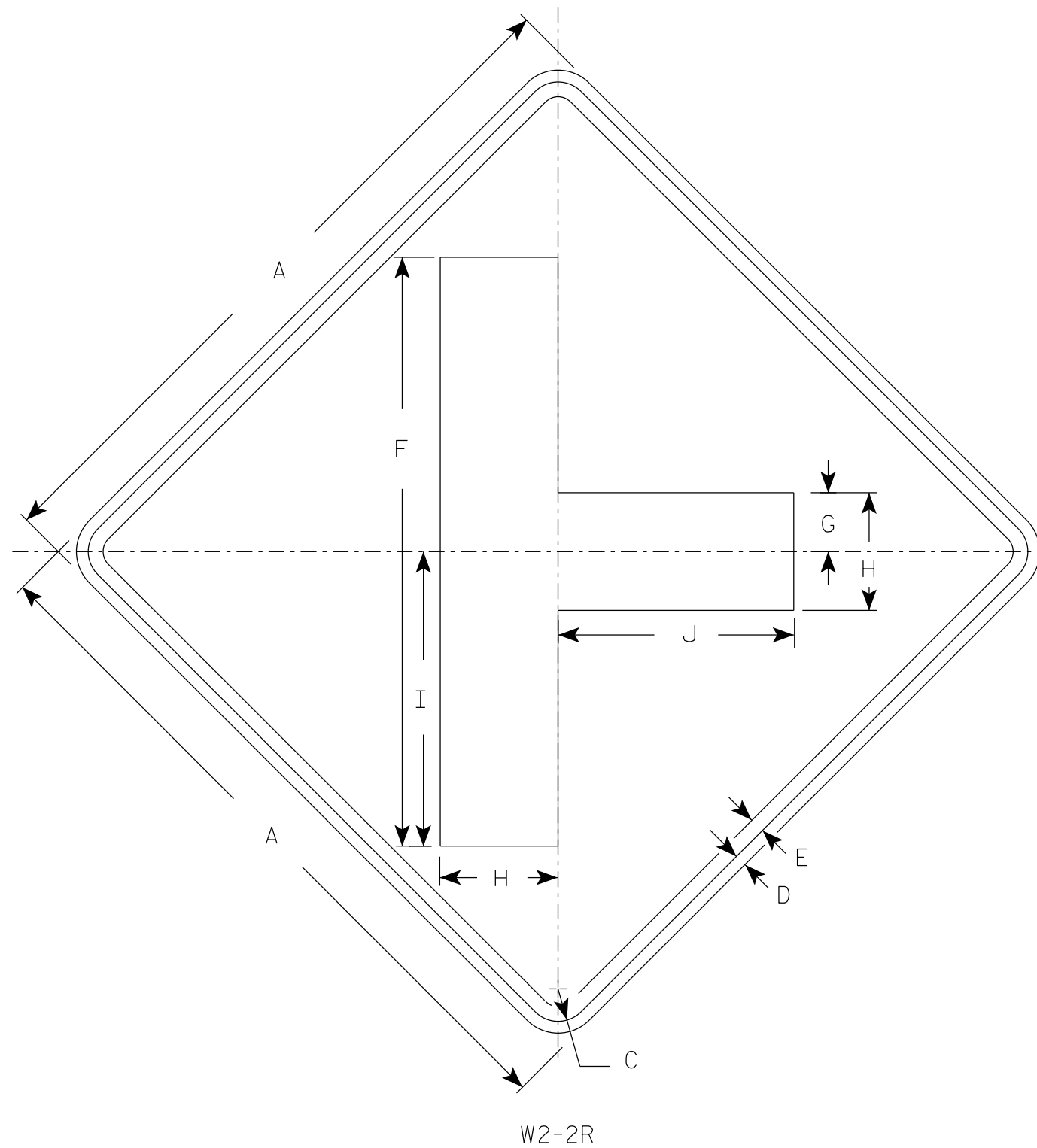

W2-2R

SIZE	A	B	C	D	E	F	G	H	I	J	K	L	M	N	O	P	Q	R	S	T	U	V	W	X	Y	Z	Area sq. ft.
1	24		1 1/8	3/8	1/2	20	2	4	10	8																	4.0
2S	30		1 3/8	1/2	5/8	25	2 1/2	5	12 1/2	10																	6.25
2M	30		1 3/8	1/2	5/8	25	2 1/2	5	12 1/2	10																	6.25
3	36		1 5/8	5/8	3/4	30	3	6	15	12																	9.0
4	48		2 1/4	3/4	1	40	4	8	20	16																	16.0
5																											

STANDARD SIGN
W2-2 L&R

WISCONSIN DEPT OF TRANSPORTATION
 APPROVED *Matthew R Rauch*
 for State Traffic Engineer
 DATE 11/18/2021 PLATE NO. W2-2.7

PROJECT NO: _____ HWY: _____ COUNTY: _____ SHEET NO: _____ **E**

7

7

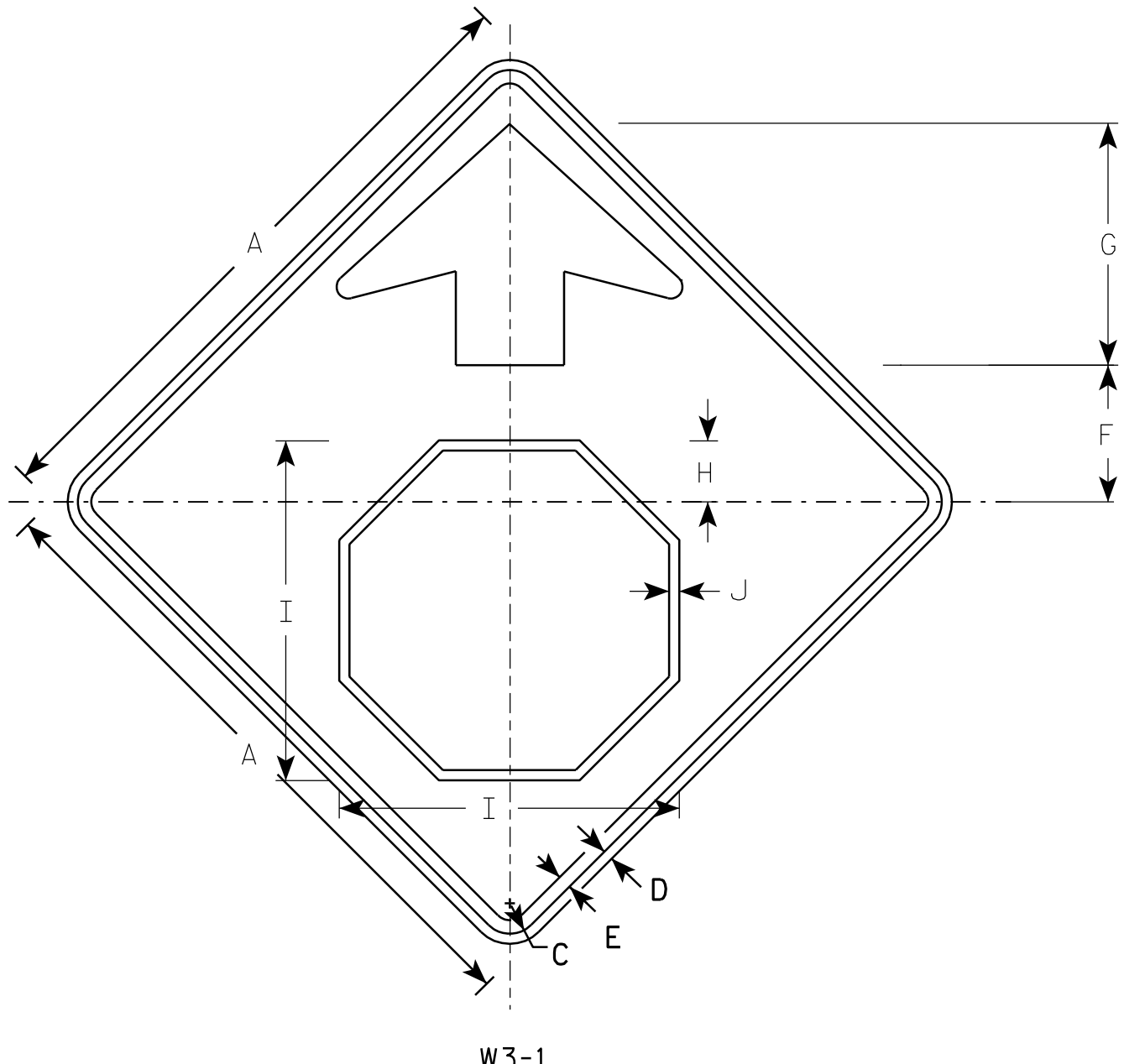

NOTES

1. All Signs Type II - Type F Reflective - reference WIS DOT Standard Specification for HIGHWAY and STRUCTURE CONSTRUCTION latest edition.
2. Color:
 Background - YELLOW
 Arrow & Border - BLACK
 Stop Symbol - WHITE BORDER ON RED BACKGROUND

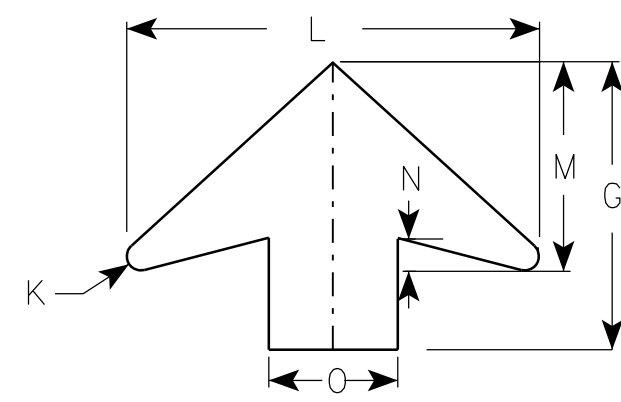

ARROW DETAIL

7

7

SIZE	A	B	C	D	E	F	G	H	I	J	K	L	M	N	O	P	Q	R	S	T	U	V	W	X	Y	Z	Area sq. ft.
1	30		1 3/8	1/2	5/8	6 1/4	11 1/4	2 7/8	15 3/4	1/2	1/2	16	8	1 1/4	5												6.25
2S	36		1 5/8	5/8	3/4	7 1/2	13 1/2	3 1/2	19	5/8	5/8	19 1/4	9 3/4	1 5/8	6												9.0
2M	36		1 5/8	5/8	3/4	7 1/2	13 1/2	3 1/2	19	5/8	5/8	19 1/4	9 3/4	1 5/8	6												9.0
3	36		1 5/8	5/8	3/4	7 1/2	13 1/2	3 1/2	19	5/8	5/8	19 1/4	9 3/4	1 5/8	6												9.0
4	48		2 1/4	3/4	1	10	17 7/8	4 1/2	25 1/8	3/4	7/8	25 5/8	13	2	8												16.0
5	48		2 1/4	3/4	1	10	17 7/8	4 1/2	25 1/8	3/4	7/8	25 5/8	13	2	8												16.0

STANDARD SIGN
W3-1

WISCONSIN DEPT OF TRANSPORTATION

APPROVED *Matthew R. Rauch*
for State Traffic Engineer

DATE 6/7/10 PLATE NO. W3-1.12

PROJECT NO: _____ SHEET NO: _____ E

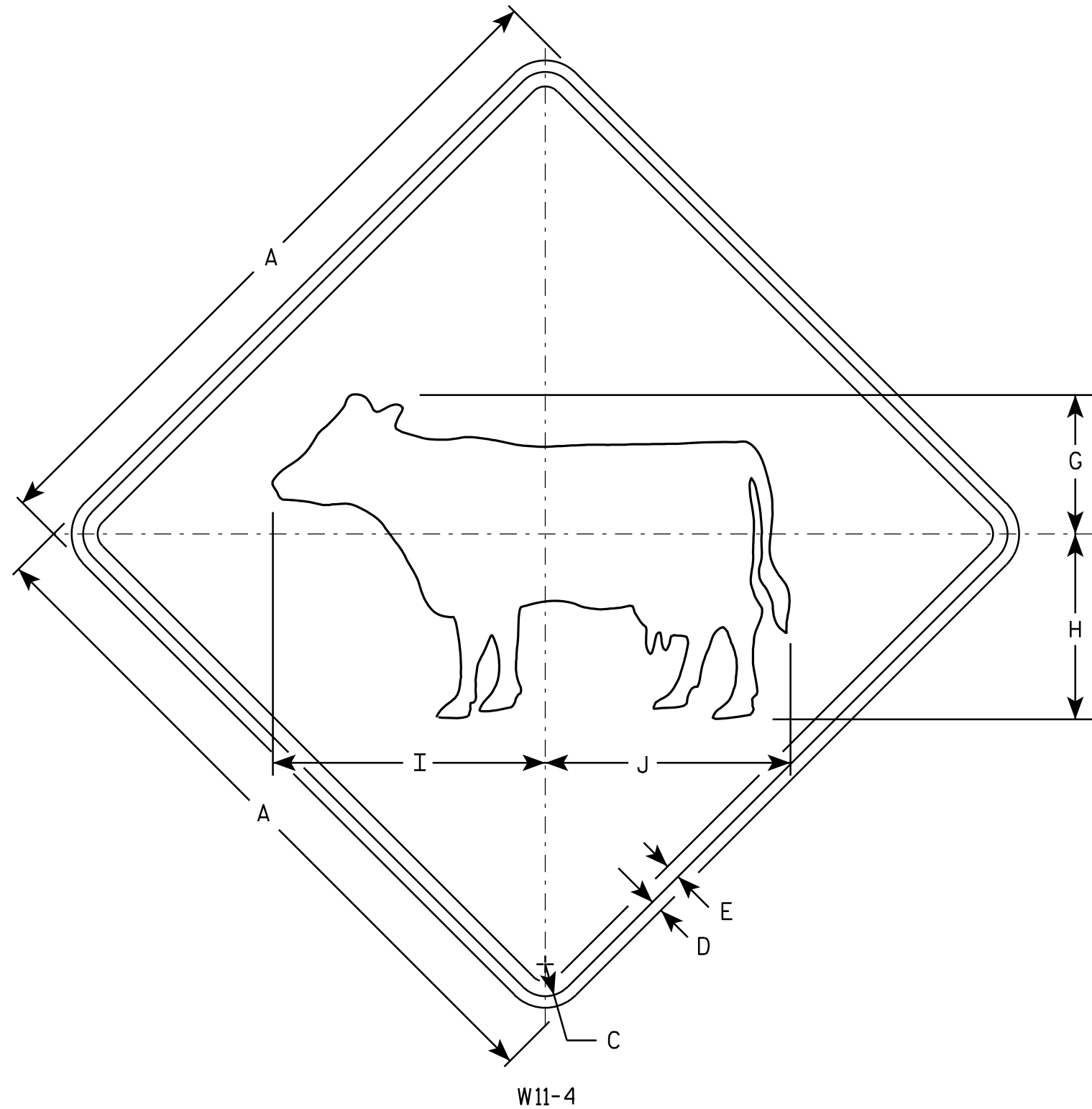

NOTES

1. Sign is Type II - Type F Reflective - reference WIS DOT Standard Specification for HIGHWAY and STRUCTURE CONSTRUCTION latest edition.
2. Color:
 Background - Yellow
 Message - Black
3. Corners may be square or rounded when base material is plywood but borders shall be rounded as shown. When base material is metal, the corners and borders shall be rounded.

W11-4

SIZE	A	B	C	D	E	F	G	H	I	J	K	L	M	N	O	P	Q	R	S	T	U	V	W	X	Y	Z	Area sq. ft.
1	24		1 1/8	3/8	1/2		4 3/4	6 3/8	9 1/4	8 3/8																	4.0
2S	30		1 3/8	1/2	5/8		6	8	11 3/4	10 1/2																	6.25
2M	30		1 3/8	1/2	5/8		6	8	11 3/4	10 1/2																	6.25
3	36		1 5/8	5/8	3/4		7 1/4	9 5/8	14 1/8	12 5/8																	9.0
4	36		1 5/8	5/8	3/4		7 1/4	9 5/8	14 1/8	12 5/8																	9.0
5	48		2 1/4	3/4	1		9 1/2	12 5/8	18 1/2	16 5/8																	16.0

STANDARD SIGN
W11-4

WISCONSIN DEPT OF TRANSPORTATION

APPROVED *Matthew R. Rauch*
for State Traffic Engineer

DATE 3/13/13 PLATE NO. W11-4.5

PROJECT NO: _____ HWY: _____ COUNTY: _____ SHEET NO: **E**

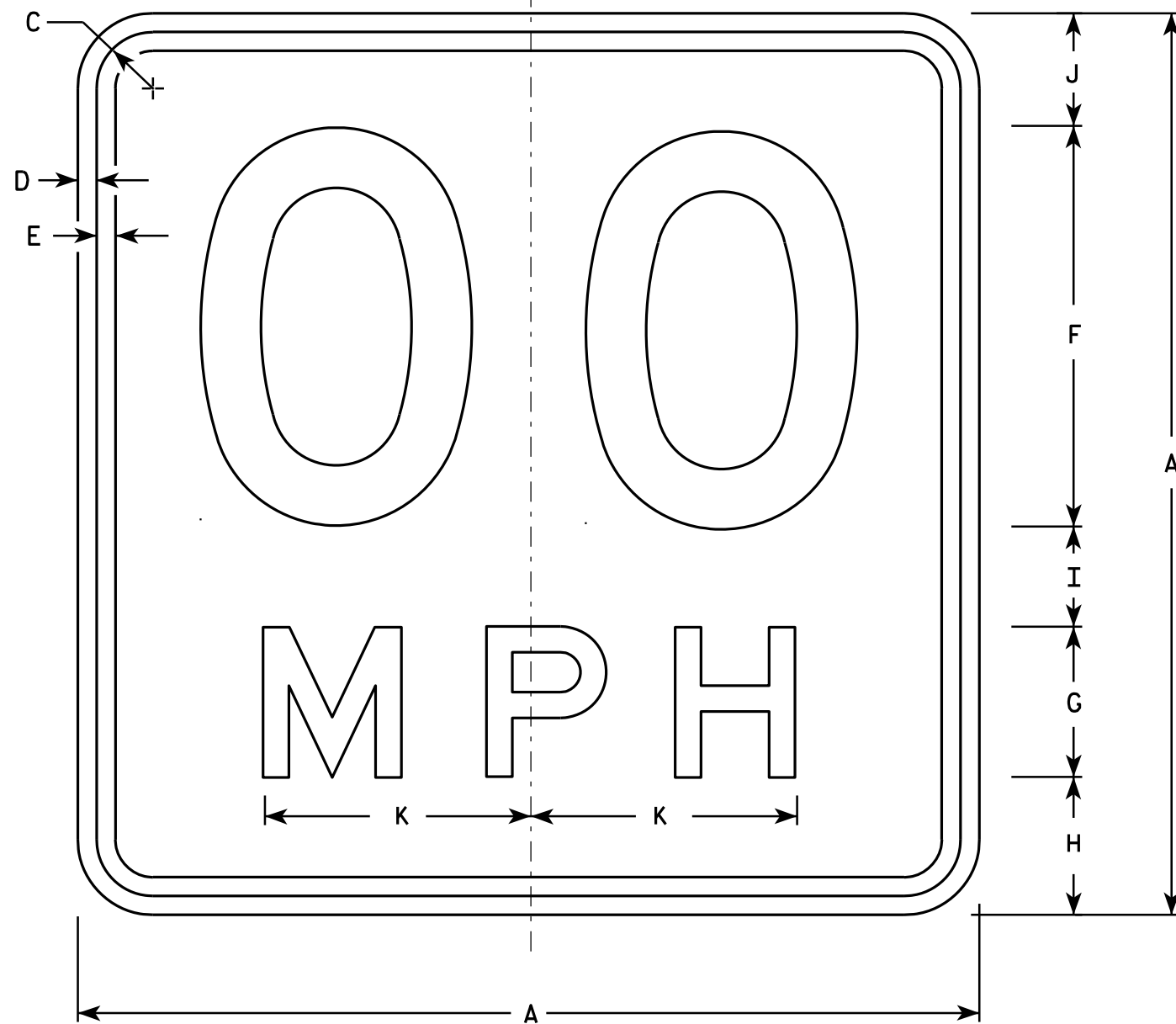

NOTES

1. Sign is Type II - Type F Reflective - reference WIS DOT Standard Specification for HIGHWAY and STRUCTURE CONSTRUCTION latest edition.
2. Color:
Background - Yellow
Message - Black
3. Message Series - See Note 6
4. Corners may be square or rounded when base material is plywood but borders shall be rounded as shown. When base material is metal, the corners and borders shall be rounded.
5. Substitute appropriate numerals and optically space about centerline to achieve proper balance.
6. Line 1 is Series D
Line 2 is Series E

W13-1

* For 30" x 30" Warning Signs, use 18" x 18" W13-1 signs.
For 36" x 36" Warning Signs, use 24" x 24" W13-1 signs.

SIZE	A	B	C	D	E	F	G	H	I	J	K	L	M	N	O	P	Q	R	S	T	U	V	W	X	Y	Z	Area sq. ft.
1	18		1 1/8	3/8	3/8	8	3	2 3/4	2	2 1/4	5 3/8																2.25
* 2S	18		1 1/8	3/8	3/8	8	3	2 3/4	2	2 1/4	5 3/8																2.25
* 2M	18		1 1/8	3/8	3/8	8	3	2 3/4	2	2 1/4	5 3/8																2.25
3	24		1 1/8	3/8	1/2	10	4	4	2 3/4	3 1/4	6 5/8																4.00
4	36		1 5/8	5/8	3/4	16	6	5 1/2	4	4 1/2	10 5/8																9.00
5	36		1 5/8	5/8	3/4	16	6	5 1/2	4	4 1/2	10 5/8																9.00

STANDARD SIGN
W13-1

WISCONSIN DEPT OF TRANSPORTATION

APPROVED *Matthew R. Rauch*
For State Traffic Engineer

DATE 5/31/12 PLATE NO. W13-1.16

PROJECT NO:

HWY:

COUNTY:

SHEET NO:

E

NOTES

1. Sign is Type II - Type F Reflective
2. Color:
Background - Yellow
Message - Black
3. Message Series - Lines 1 and 2 are Series D.
Line 3 is series C.
4. Corners and borders shall be rounded on all base materials for this sign.

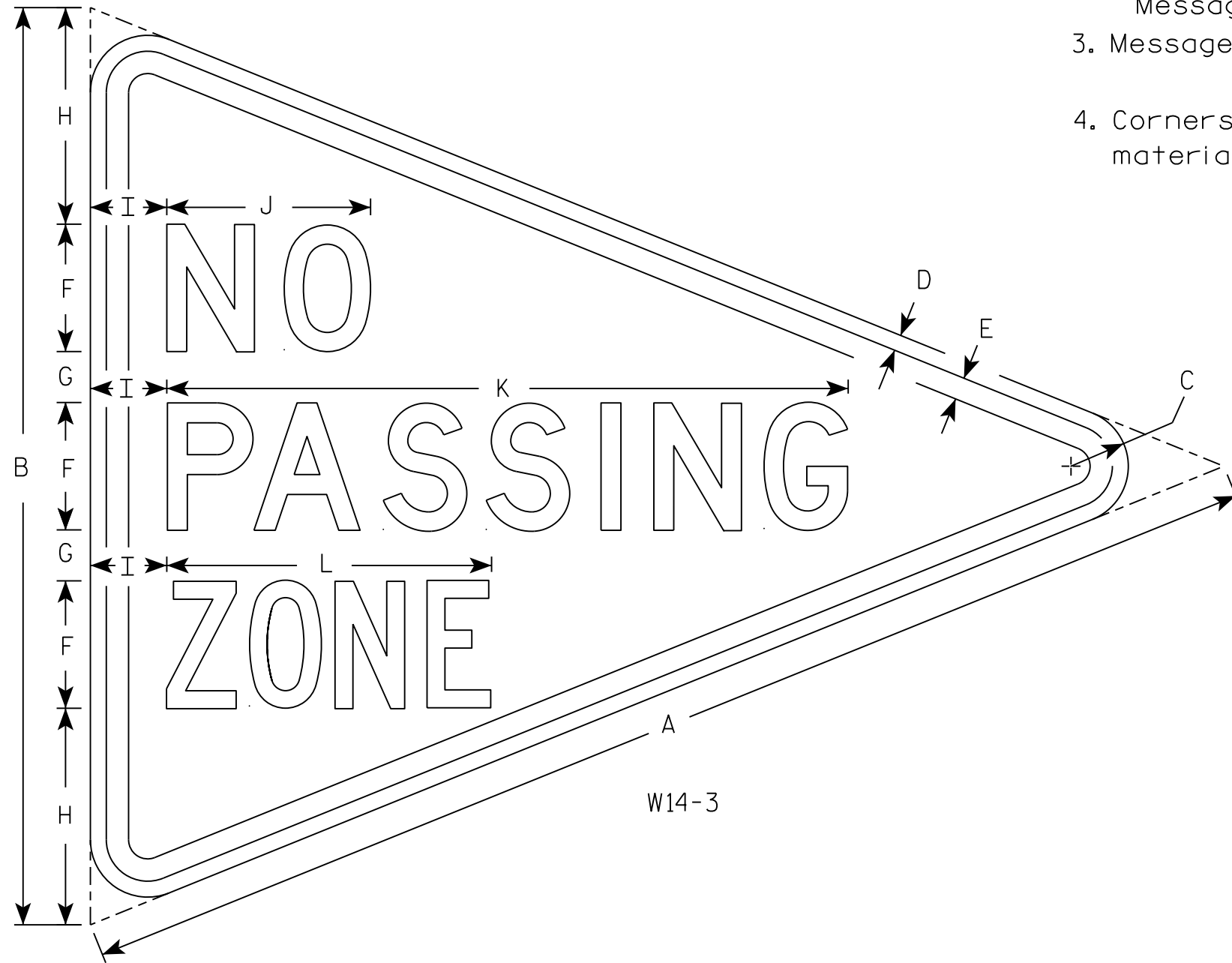

7

7

SIZE	A	B	C	D	E	F	G	H	I	J	K	L	M	N	O	P	Q	R	S	T	U	V	W	X	Y	Z	Area sq. ft.
1																											
2S	48	36	2 1/4	5/8	7/8	5	2	8 1/2	3	8	26 3/4	12 3/4															5.56
2M																											
3																											
4																											
5																											

STANDARD SIGN
W14-3

WISCONSIN DEPT OF TRANSPORTATION

APPROVED *Matthew R Rauch*
for State Traffic Engineer

DATE 3/21/17 PLATE NO. W14-3.10

PROJECT NO: _____ HWY: _____ COUNTY: _____ SHEET NO: **E**

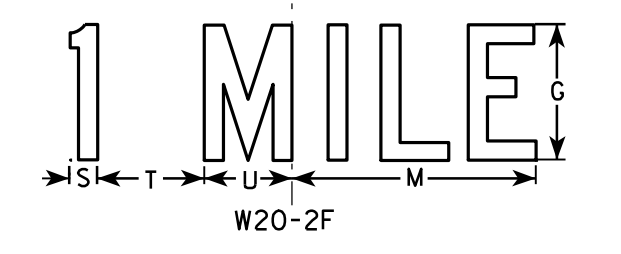
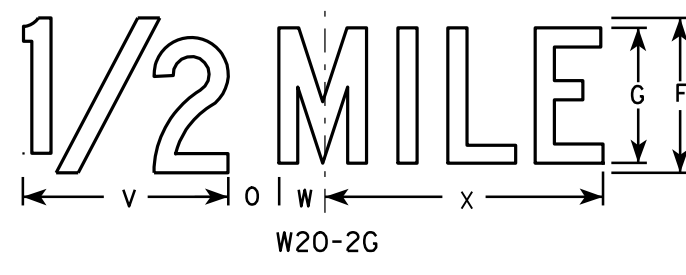
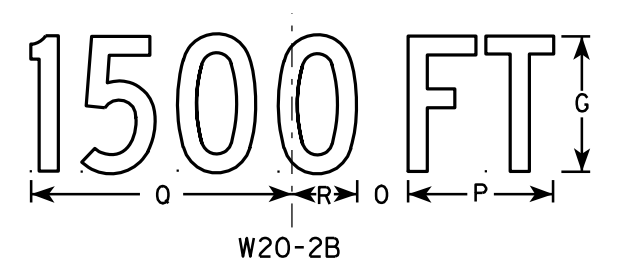
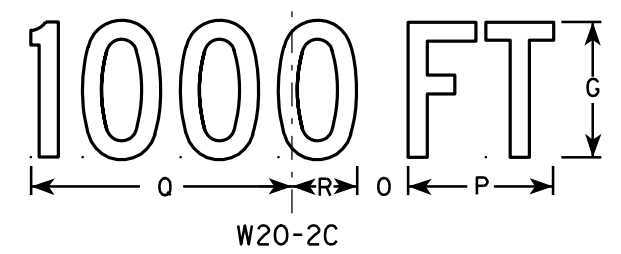
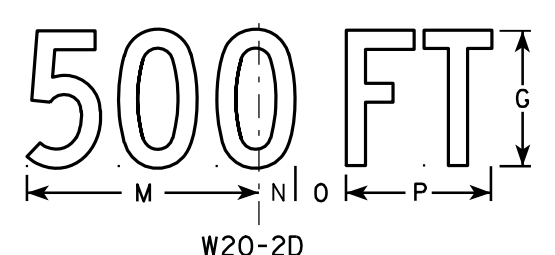
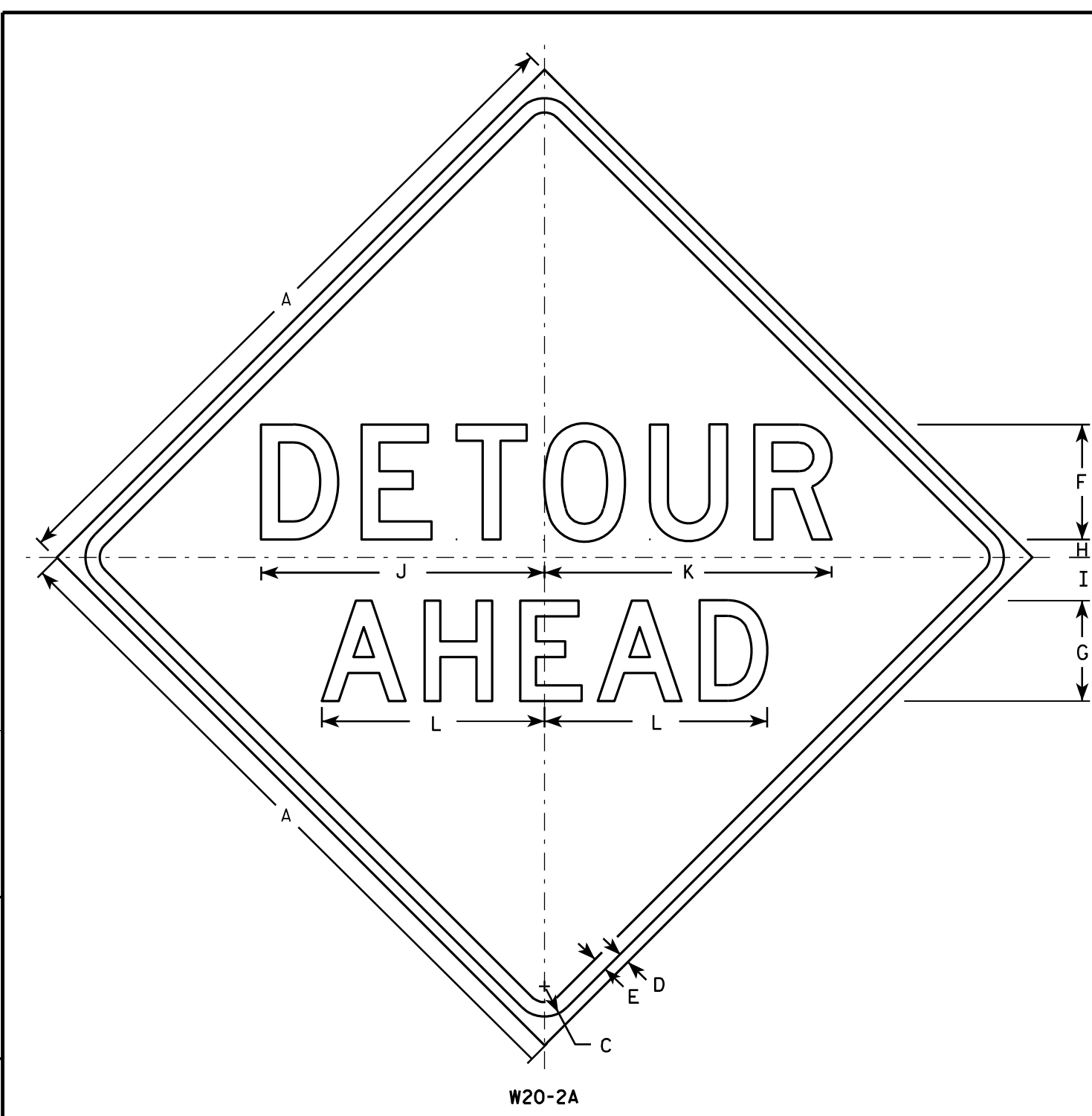

NOTES

1. Sign is Type II - Type F Reflective - reference WIS DOT Standard Specification for HIGHWAY and STRUCTURE CONSTRUCTION latest edition.
2. Color:
Background - Orange
Message - Black
3. Message Series - See note 5
4. Corners may be square or rounded when base material is plywood but borders shall be rounded as shown. When base material is metal, the corners and borders shall be rounded.
5. Line 1 is Series D.
Line 2 is Series D for AHEAD and Series C for all other distances.

7

7

SIZE	A	B	C	D	E	F	G	H	I	J	K	L	M	N	O	P	Q	R	S	T	U	V	W	X	Y	Z	Area sq. ft.
1	36		1 5/8	5/8	3/4	6	5	1	2 1/4	14 3/4	15	11 5/8	9	1 3/8	1 7/8	5 5/8	10 1/8	2 1/2	1 1/8	4 1/2	3 1/2	8	1 3/4	10 3/4			9.0
2S	48		2 1/4	3/4	1	8	7	1 1/4	3	19 3/4	20	15 1/2	12	1 7/8	2 5/8	7 1/2	13 1/2	3 3/8	1 1/2	6	4 5/8	10 5/8	2 3/8	14 3/8			16.0
2M	48		2 1/4	3/4	1	8	7	1 1/4	3	19 3/4	20	15 1/2	12	1 7/8	2 5/8	7 1/2	13 1/2	3 3/8	1 1/2	6	4 5/8	10 5/8	2 3/8	14 3/8			16.0
3	48		2 1/4	3/4	1	8	7	1 1/4	3	19 3/4	20	15 1/2	12	1 7/8	2 5/8	7 1/2	13 1/2	3 3/8	1 1/2	6	4 5/8	10 5/8	2 3/8	14 3/8			16.0
4	48		2 1/4	3/4	1	8	7	1 1/4	3	19 3/4	20	15 1/2	12	1 7/8	2 5/8	7 1/2	13 1/2	3 3/8	1 1/2	6	4 5/8	10 5/8	2 3/8	14 3/8			16.0
5	48		2 1/4	3/4	1	8	7	1 1/4	3	19 3/4	20	15 1/2	12	1 7/8	2 5/8	7 1/2	13 1/2	3 3/8	1 1/2	6	4 5/8	10 5/8	2 3/8	14 3/8			16.0

STANDARD SIGN
W20-2A, B, C, D, F & G

WISCONSIN DEPT OF TRANSPORTATION

APPROVED *Matthew R. Raub*
for State Traffic Engineer

DATE 3/18/11 PLATE NO. W20-2.6

PROJECT NO: _____ HWY: _____ COUNTY: _____ SHEET NO: _____ E

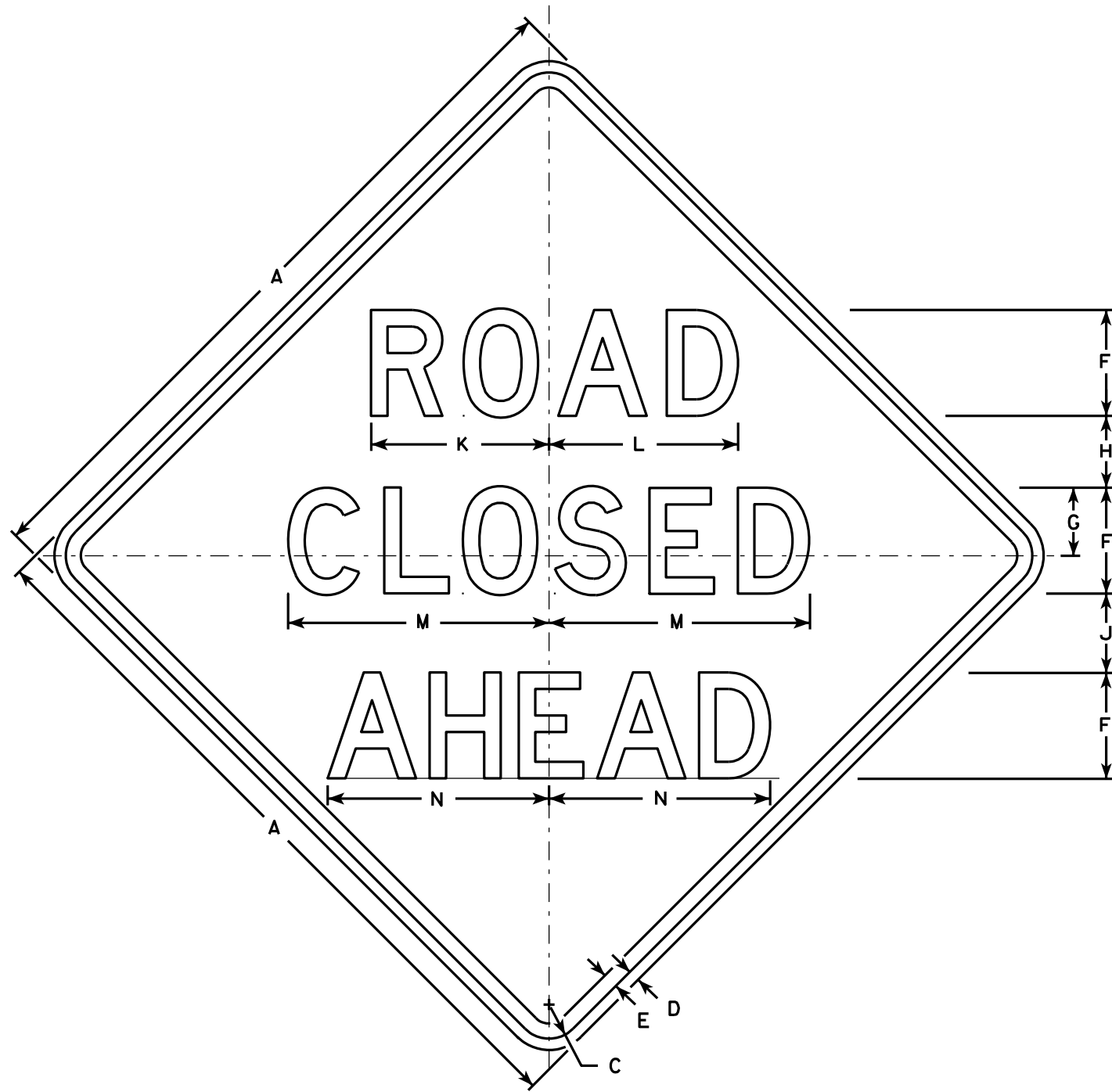

W20-3A

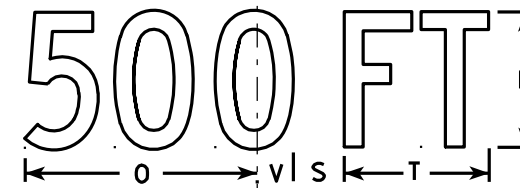

W20-3D

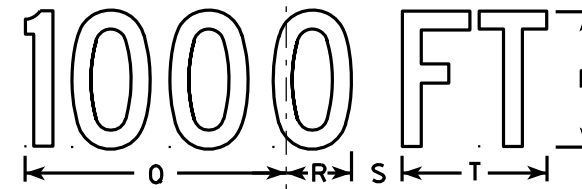

W20-3C

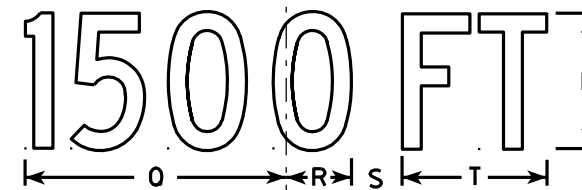

W20-3B

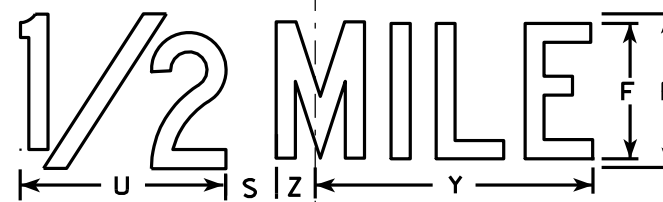

W20-3G



W20-3F

NOTES

1. Sign is Type II - Type F Reflective - reference WIS DOT Standard Specification for HIGHWAY and STRUCTURE CONSTRUCTION latest edition.
2. Color:
Background - Orange
Message - Black
3. Message Series - see note 5
4. Corners may be square or rounded when base material is plywood but borders shall be rounded as shown. When base material is metal, the corners and borders shall be rounded.
5. Lines 1 and 2 are Series D.
Line 3 is Series D for AHEAD and Series C for all other distances.

7

7

SIZE	A	B	C	D	E	F	G	H	I	J	K	L	M	N	O	P	Q	R	S	T	U	V	W	X	Y	Z	Area sq. ft.
1	36		1 5/8	5/8	3/4	5	3 3/8	3 1/2	1 1/8	4	8 3/8	8 7/8	12 1/2	11	9	6	10 1/8	2 1/2	1 7/8	5 5/8	8	1 3/8	4 1/2	3 1/2	10 3/4	1 3/4	9.0
2S	48		2 1/4	3/4	1	7	4 1/2	4 3/4	1 1/2	5 1/4	11 3/4	12 1/2	17 1/4	14 5/8	12	8	13 1/2	3 3/8	2 5/8	7 1/2	10 5/8	1 7/8	6	4 5/8	14 3/8	2 3/8	16.0
2M	48		2 1/4	3/4	1	7	4 1/2	4 3/4	1 1/2	5 1/4	11 3/4	12 1/2	17 1/4	14 5/8	12	8	13 1/2	3 3/8	2 5/8	7 1/2	10 5/8	1 7/8	6	4 5/8	14 3/8	2 3/8	16.0
3	48		2 1/4	3/4	1	7	4 1/2	4 3/4	1 1/2	5 1/4	11 3/4	12 1/2	17 1/4	14 5/8	12	8	13 1/2	3 3/8	2 5/8	7 1/2	10 5/8	1 7/8	6	4 5/8	14 3/8	2 3/8	16.0
4	48		2 1/4	3/4	1	7	4 1/2	4 3/4	1 1/2	5 1/4	11 3/4	12 1/2	17 1/4	14 5/8	12	8	13 1/2	3 3/8	2 5/8	7 1/2	10 5/8	1 7/8	6	4 5/8	14 3/8	2 3/8	16.0
5	48		2 1/4	3/4	1	7	4 1/2	4 3/4	1 1/2	5 1/4	11 3/4	12 1/2	17 1/4	14 5/8	12	8	13 1/2	3 3/8	2 5/8	7 1/2	10 5/8	1 7/8	6	4 5/8	14 3/8	2 3/8	16.0

STANDARD SIGN
W20-3A, B, C, D, F & G

WISCONSIN DEPT OF TRANSPORTATION

APPROVED *Matthew R. Rauch*
For State Traffic Engineer

DATE 3/18/11 PLATE NO. W20-3.7

PROJECT NO: _____ HWY: _____ COUNTY: _____ SHEET NO: _____ E

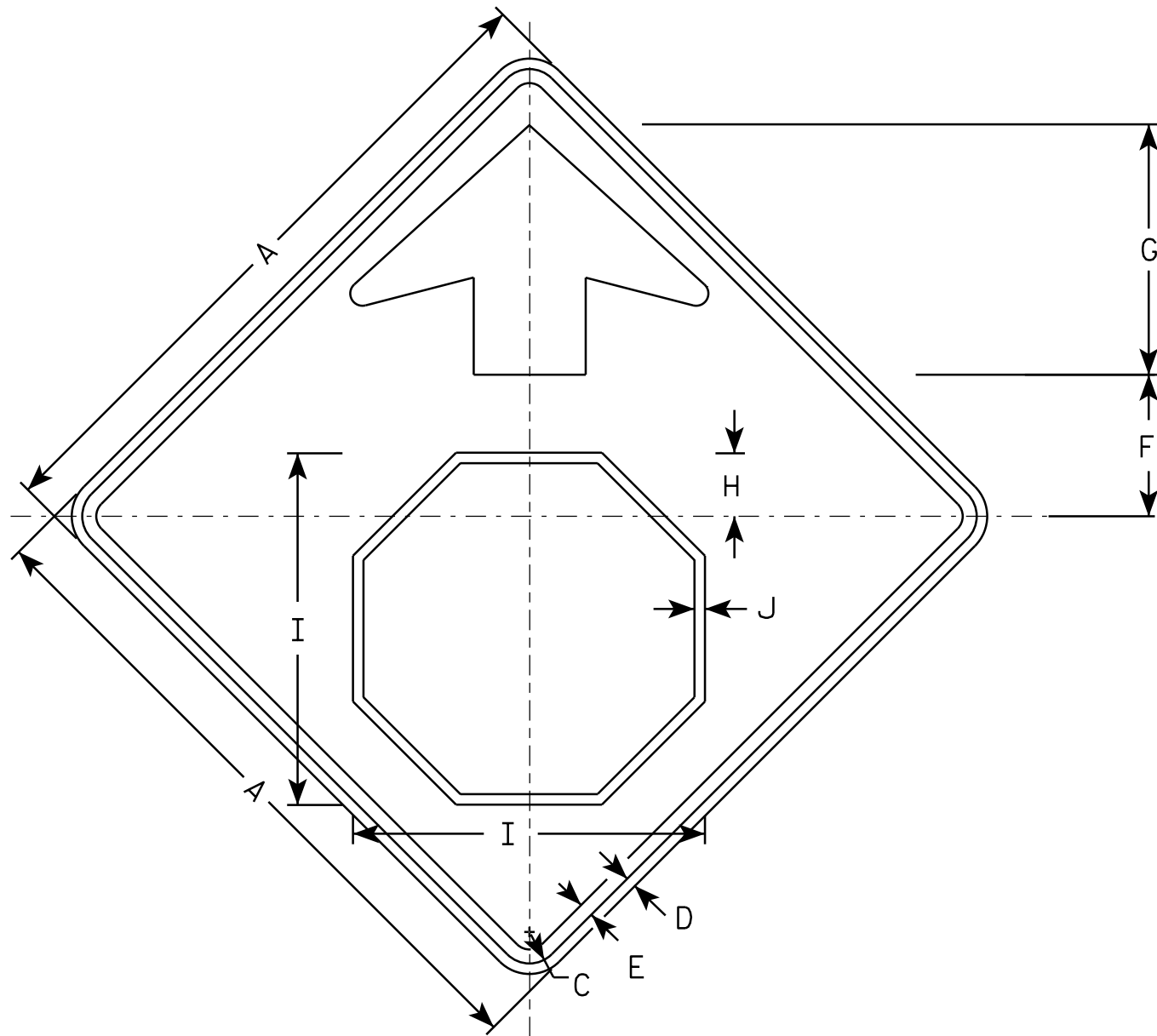

W03-1

NOTES

1. All Signs Type II - Type F Reflective - reference WIS DOT Standard Specification for HIGHWAY and STRUCTURE CONSTRUCTION latest edition.
2. Color:
 Background - ORANGE
 Arrow & Border - BLACK
 Stop Symbol - WHITE BORDER ON RED BACKGROUND

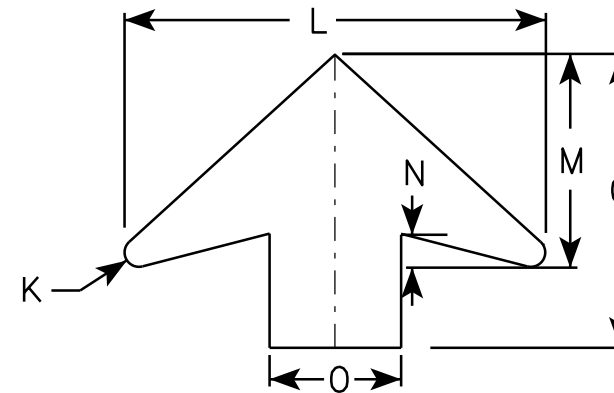

ARROW DETAIL

SIZE	A	B	C	D	E	F	G	H	I	J	K	L	M	N	O	P	Q	R	S	T	U	V	W	X	Y	Z	Area sq. ft.
1	36		1 5/8	5/8	3/4	7 1/2	13 1/2	3 1/2	19	5/8	5/8	19 1/4	9 3/4	1 5/8	6												9.0
2S	48		2 1/4	3/4	1	10	17 7/8	4 1/2	25 1/8	3/4	7/8	25 5/8	13	2	8												16.0
2M	48		2 1/4	3/4	1	10	17 7/8	4 1/2	25 1/8	3/4	7/8	25 5/8	13	2	8												16.0
3	48		2 1/4	3/4	1	10	17 7/8	4 1/2	25 1/8	3/4	7/8	25 5/8	13	2	8												16.0
4	48		2 1/4	3/4	1	10	17 7/8	4 1/2	25 1/8	3/4	7/8	25 5/8	13	2	8												16.0
5	48		2 1/4	3/4	1	10	17 7/8	4 1/2	25 1/8	3/4	7/8	25 5/8	13	2	8												16.0

STANDARD SIGN
W03-1

WISCONSIN DEPT OF TRANSPORTATION

APPROVED *Matthew R. Rauch*
for State Traffic Engineer

DATE 11/20/13 PLATE NO. W03-1.1

CTH D - CULVERTS/RECONSTRUCTION

STATION	REAL STATION	DISTANCE	AREA (5F)				INCREMENTAL VOL (CY) (UNADJUSTED)				CUMULATIVE VOL (CY)			
			CUT	SALVAGED/UNUSABLE PAVEMENT MATERIAL	EILL	EB5	CUT	SALVAGED/UNUSABLE PAVEMENT MATERIAL	EILL	EB5	CUT	EXPANDED FILL	REDUCED EB5 IN EILL	MA55 ORDINATE
19+65	1,965.00	1965.00	0.00	0.00	0.00	0.00	0	0	0	0	0	0	0	0
19+84.94	1984.94	19.94	230.80	8.25	145.42	0.00	85	3	54	0	85	68	0	15
20+05	2005.00	20.06	0.00	0.00	0.00	0.00	86	3	54	0	171	135	0	30
24+03	2403.00	0.00	0.00	0.00	0.00	0.00	0	0	0	0	171	135	0	30
24+20.33	2420.33	17.33	163.26	8.25	94.16	0.00	52	3	30	0	223	173	0	42
24+37	2437.00	16.67	0.00	0.00	0.00	0.00	50	3	29	0	273	209	0	52
62+44	6,244.00	0.00	0.00	0.00	0.00	0.00	0	0	0	0	273	209	0	52
62+59.45	6259.45	15.45	125.90	8.25	51.44	0.00	36	2	15	0	309	228	0	68
62+74	6274.00	14.55	0.00	0.00	0.00	0.00	34	2	14	0	343	245	0	82
112+50.323	11250.32	0.00	17.50	8.25	6.01	55.14	0	0	0	0	343	245	0	82
113+00	11300.00	49.68	22.54	8.25	4.34	49.52	37	15	10	96	380	378	77	-29
114+00	11400.00	100.00	5.15	5.15	11.76	75.28	51	25	30	231	431	704	262	-329
115+00	11500.00	100.00	1.33	0.00	44.49	64.03	12	10	104	258	443	1,156	468	-779
115+19.812	11519.81	19.81	2.13	0.00	38.78	61.42	1	0	31	46	444	1,253	505	-875
116+00	11600.00	80.19	5.97	0.00	14.11	66.08	12	0	79	189	456	1,588	656	-1,198
117+00	11700.00	100.00	20.02	8.25	9.88	62.34	48	15	44	238	504	1,940	846	-1,517
118+00	11800.00	100.00	21.65	8.25	16.94	60.63	77	31	50	228	581	2,288	1,029	-1,819
173+69	17369.00	0.00	0.00	0.00	0.00	0.00	0	0	0	0	581	2,288	1,029	-1,819
173+86.715	17386.72	17.72	193.05	8.25	120.74	0.00	63	3	40	0	644	2,338	1,029	-1,809
174+05	17405.00	18.28	0.00	0.00	0.00	0.00	65	3	41	0	709	2,389	1,029	-1,798
179+07	17907.00	0.00	0.00	0.00	0.00	0.00	0	0	0	0	709	2,389	1,029	-1,798
179+27.254	17927.25	20.25	210.41	8.25	160.99	0.00	79	3	60	0	788	2,464	1,029	-1,797
179+47	17947.00	19.75	0.00	0.00	0.00	0.00	77	3	59	0	865	2,538	1,029	-1,797
198+49.8	19849.80	0.00	92.35	8.25	2.73	0.00	0	0	0	0	865	2,538	955	-1,723
198+50	19850.00	0.20	94.42	8.25	2.31	0.00	1	0	0	0	866	2,538	882	-1,649
198+50	19850.00	0.00	94.42	8.25	2.31	0.00	0	0	0	0	866	2,538	808	-1,575
200+00	20000.00	150.00	0.00	0.00	118.15	0.00	262	23	335	0	1,128	2,956	735	-1,681
201+00	20100.00	100.00	0.00	0.00	335.24	0.00	0	0	840	0	1,128	4,006	661	-2,658
201+62	20162.00	62.00	0.02	0.00	535.19	0.00	0	0	999	0	1,128	5,255	588	-3,833
201+78.646	20178.65	16.65	184.52	8.25	663.31	0.00	57	3	369	0	1,185	5,716	514	-4,167
201+96	20196.00	17.35	0.00	0.00	628.47	0.00	59	3	415	0	1,244	6,235	441	-4,556
202+00	20200.00	4.00	0.00	0.00	642.42	0.00	0	0	94	0	1,244	6,353	367	-4,600
202+79.9	20279.90	79.90	0.00	0.00	672.48	0.00	0	0	1,946	0	1,244	8,785	294	-6,959
203+00	20300.00	20.10	0.00	0.00	624.31	0.00	0	0	483	0	1,244	9,389	220	-7,489
203+04.9	20304.90	4.90	0.00	0.00	601.52	0.00	0	0	111	0	1,244	9,528	147	-7,555
203+29.9	20329.90	25.00	0.36	0.00	504.85	0.00	0	0	512	0	1,244	10,168	73	-8,121
204+00	20400.00	70.10	28.77	0.00	565.32	0.00	38	0	1,389	0	1,282	11,904	0	-9,746

Notes:

- 1 - CUT
- 2 - SALVAGED/UNUSABLE PAVEMENT MATERIAL
- 3 - EILL
- 4 - REDUCED EBS IN EILL
- 5 - MASS ORDINATE

CUT INCLUDES SALVAGED/UNUSABLE PAVEMENT MATERIAL
 THIS DOES NOT SHOW UP IN CROSS SECTIONS
 DOES NOT INCLUDE UNUSABLE PAVEMENT EXC VOLUME, INCLUDES EBS VOLUME
 REDUCED EBS TO BE USED IN EILL OUTSIDE OF ROADWAY FOUNDATION
 STA 19+65 - 179+47 EBS TO BE BACKFILLED WITH COMMON OR BORROW: $[(CUT - SALVAGED PAVT) - (FILL + EBS AREA) * EILL FACTOR]$
 STA 198+49.8 - 204+00 REDUCED EBS IN EILL OUTSIDE OF ROADWAY FOUNDATION: $[(CUT - SALVAGED PAVT + REDUCED EBS IN EILL) - (EILL * EILL FACTOR)]$

9

9

PROJECT NO: 7823-07-73

HWY: CTH D

COUNTY: EAU CLAIRE

CROSS SECTIONS: EARTHWORK

SHEET

E

STH27-SHOULDER

STATION	DISTANCE	AREA (SF)			INCREMENTAL VOL (CY) (UNADJUSTED)			CUMULATIVE VOL (CY)	
		CUT	SALVAGED/UNUSABLE PAVEMENT MATERIAL	EILL	CUT NOTE 1	SALVAGED/UNUSABLE PAVEMENT MATERIAL NOTE 2	FILL NOTE 3	CUT 1.00 NOTE 1	MASS ORDINATE NOTE 5
551+20.845	0.00	3.00	0.00	0.00	0	0	0	0	0
551+50	29.16	12.28	0.00	0.00	8	0	0	8	8
552+00.00	50.00	64.96	0.00	0.00	72	0	0	80	80
552+50.212	50.21	19.74	0.00	0.00	79	0	0	159	159
553+00	49.79	72.76	0.00	0.00	85	0	0	244	244
553+50	50.00	18.05	0.00	0.00	84	0	0	328	328
554+00	50.00	72.64	0.00	0.00	84	0	0	412	412
554+50	50.00	5.91	0.00	33.09	73	0	31	485	454
556+35	185.50	1.80	0.00	9.54	26	0	146	511	334
556+50	14.50	1.89	0.00	0.50	1	0	3	512	332
556+68.889	18.89	3.55	0.00	0.00	2	0	0	514	334

LUDINGTON

STATION	REAL STATION	DISTANCE	AREA (SF)				INCREMENTAL VOL (CY) (UNADJUSTED)				CUMULATIVE VOL (CY)			
			CUT	SALVAGED/UNUSABLE PAVEMENT MATERIAL	FILL	EBS	CUT NOTE 1	SALVAGED/UNUSABLE PAVEMENT MATERIAL NOTE 2	FILL NOTE 3	EBS	CUT 1.00 NOTE 1	EXPANDED FILL 1.25	REDUCED EBS IN FILL 0.80 NOTE 4	MASS ORDINATE NOTE 5
300+50	30050.00	0.00	19.76	0.00	37.66	84.53	0	0	0	0	0	0	0	0
300+93.554	30093.55	43.55	28.73	8.25	0.33	0.00	39	7	31	68	39	124	54	-92
301+50	30150.00	56.45	43.16	8.25	1.18	0.00	75	17	2	0	114	126	54	-36
301+63.5	30163.50	13.50	31.42	8.25	2.12	0.00	19	4	1	0	133	128	54	-23

Notes:	
1 - CUT	CUT INCLUDES SALVAGED/UNUSABLE PAVEMENT MATERIAL
2 - SALVAGED/UNUSABLE PAVEMENT MATERIAL	THIS DOES NOT SHOW UP IN CROSS SECTIONS
3 - FILL	DOES NOT INCLUDE UNUSABLE PAVEMENT EXC VOLUME, INCLUDES EBS VOLUME
4 - REDUCED EBS IN FILL	REDUCED EBS TO BE USED IN FILL OUTSIDE OF ROADWAY FOUNDATION
5 - MASS ORDINATE	EBS TO BE BACKFILLED WITH COMMON OR BORROW: $[(CUT - SALVAGED PAVT) - (FILL + EBS AREA) * FILL FACTOR]$

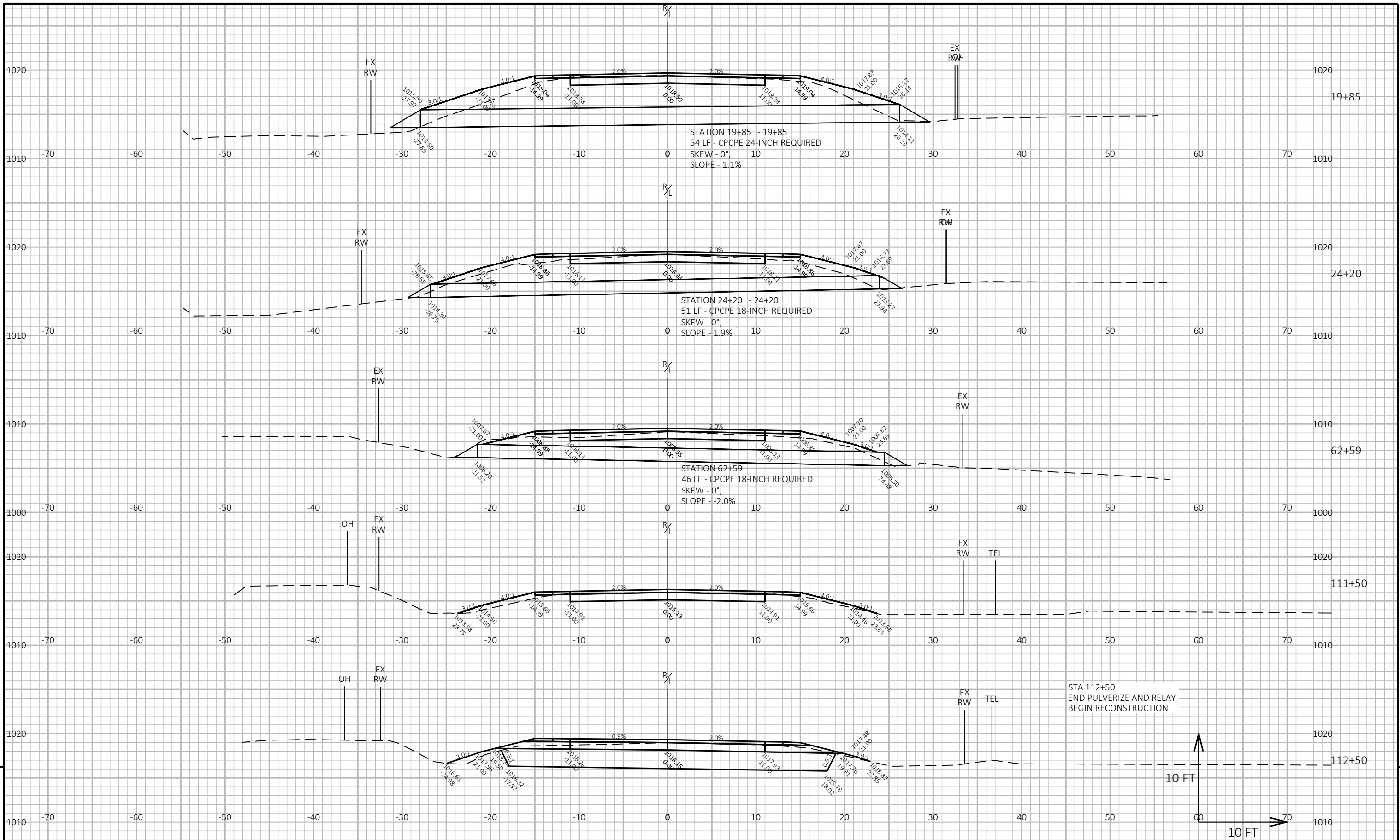

9
1010
-70
-60
-50
-40
-30
-20
-10
0
10
20
30
40
50
60
70
80
90
1010
9

PROJECT NO: 7823-07-73	HWY: CTH D	COUNTY: EAU CLAIRE	CROSS SECTIONS: CTH D	SHEET E
------------------------	------------	--------------------	-----------------------	---------

FILE NAME : C:\OD\CORRE, INC\PROJECTS - DOCUMENTS\WI - NW REGION\7823-07-03_EAU CLAIRE CO_CTH D\500_CADD\501_C3D_2018\78230703\SHEETS\PLAN\090201-XS.DWG
 PLOT DATE : 2/18/2022 11:34 AM
 PLOT BY : BOBBY JONES
 PLOT NAME :
 PLOT SCALE : 1 IN:10 FT HORZ. / 1 IN:10 FT VERT.
 WISDOT/CADD SHEET 49

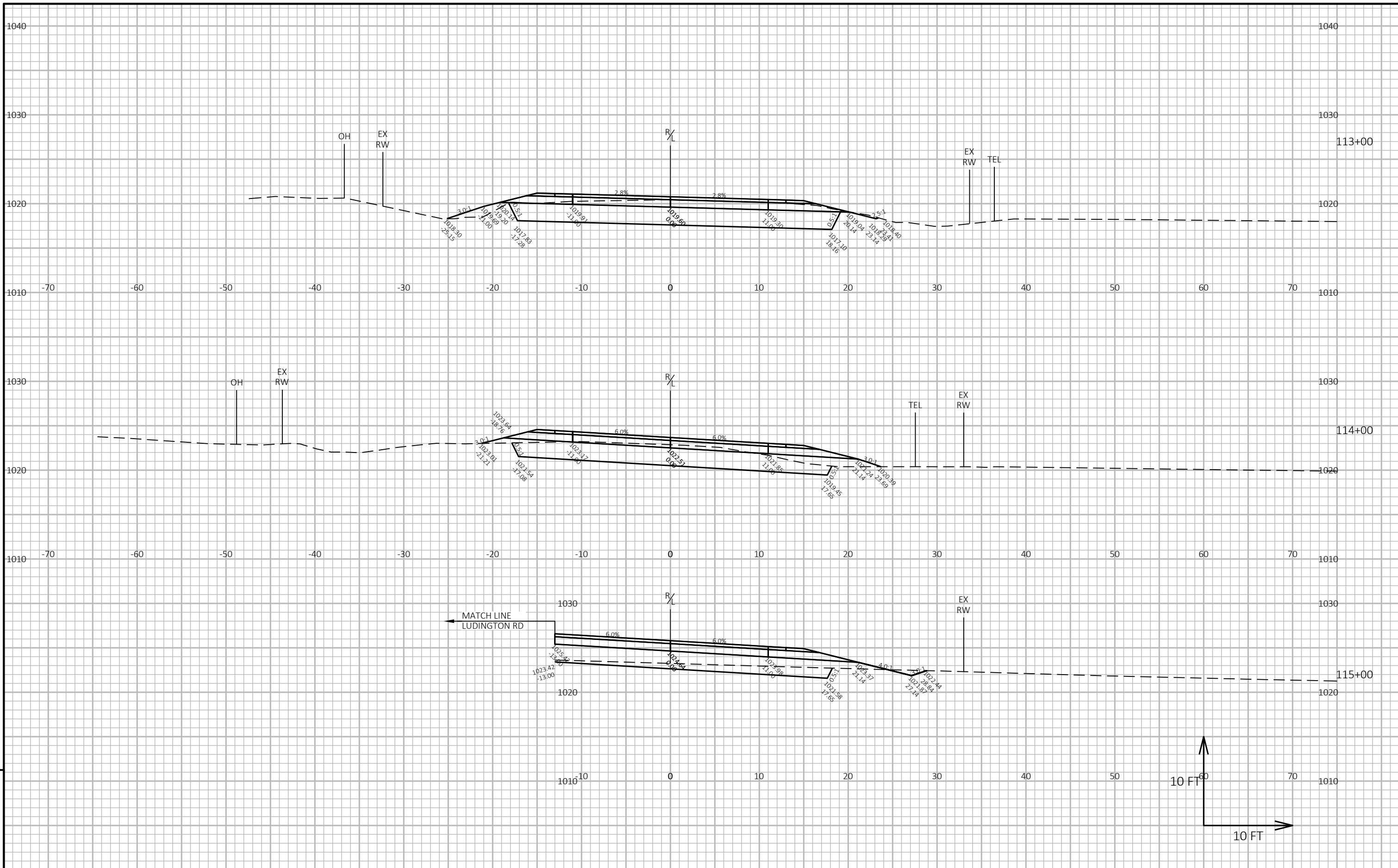

PROJECT NO: 7823-07-73

HWY: CTH D

COUNTY: EAU CLAIRE

CROSS SECTIONS: CTH D

SHEET

E

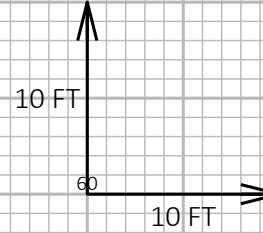
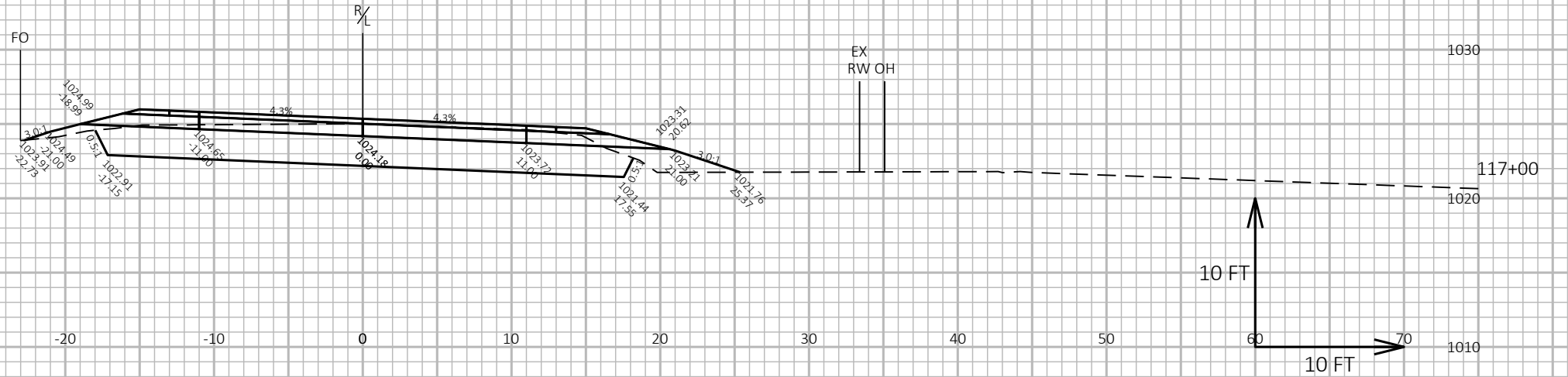
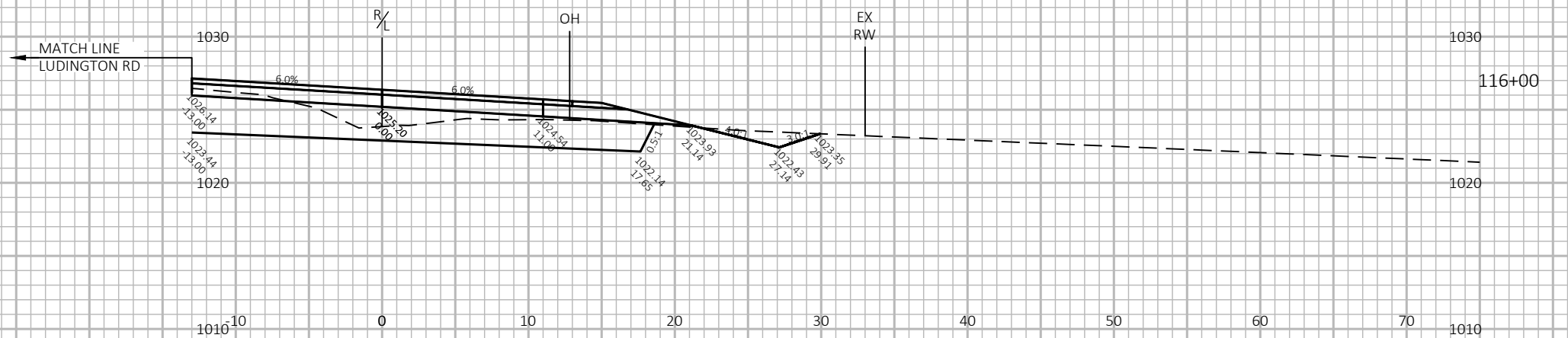
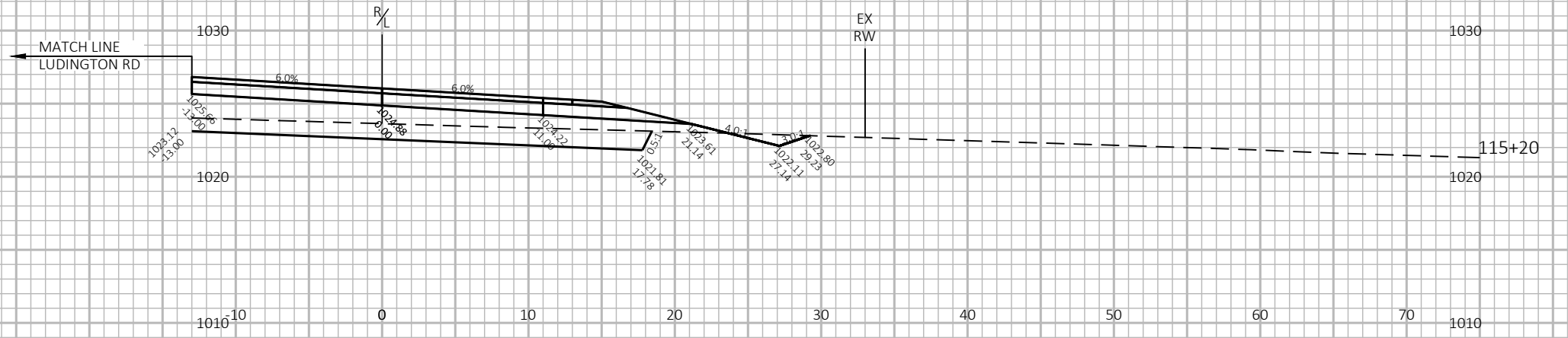

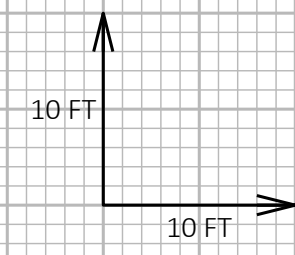
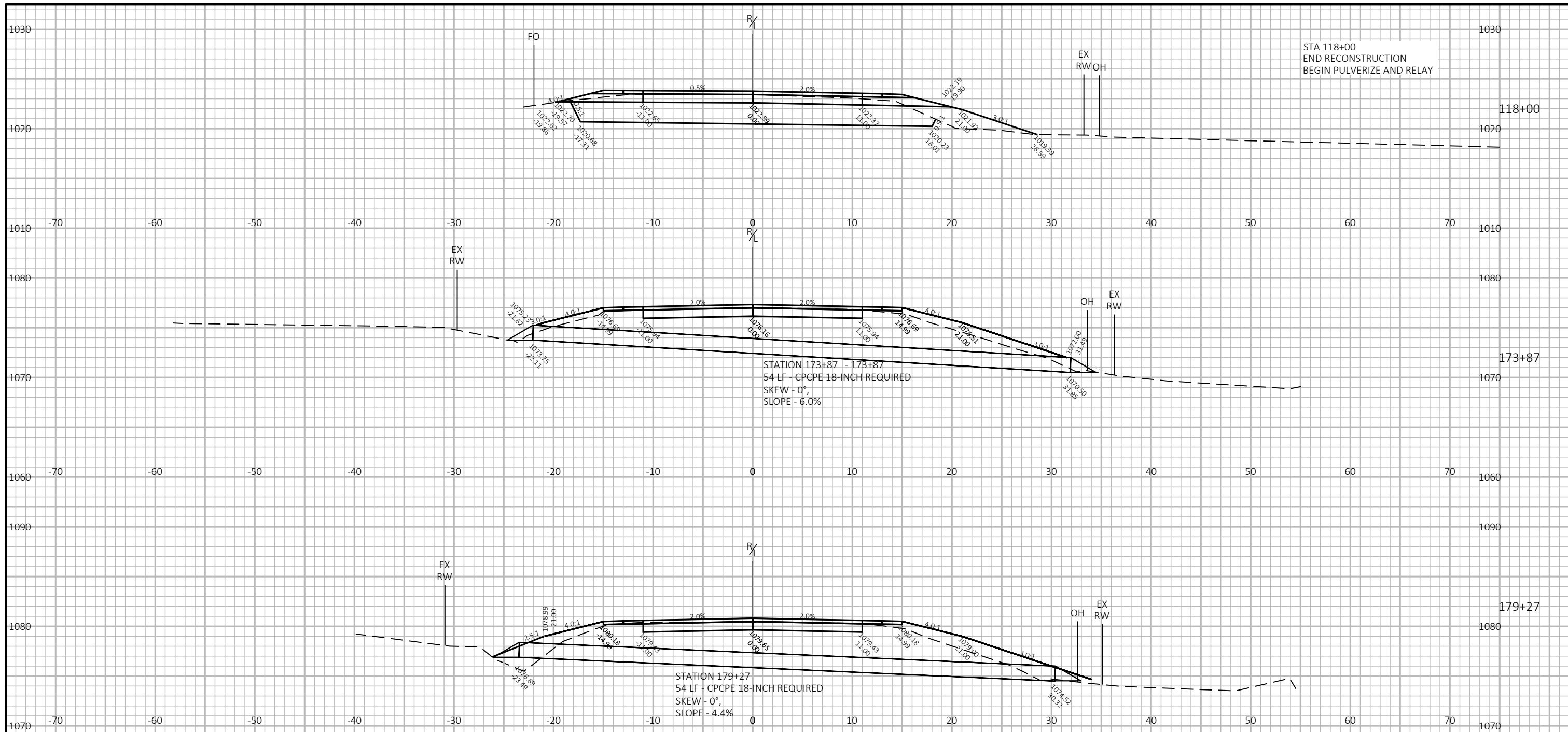

9

9

PROJECT NO: 7823-07-73	HWY: CTH D	COUNTY: EAU CLAIRE	CROSS SECTIONS: CTH D	SHEET	E
------------------------	------------	--------------------	-----------------------	-------	---

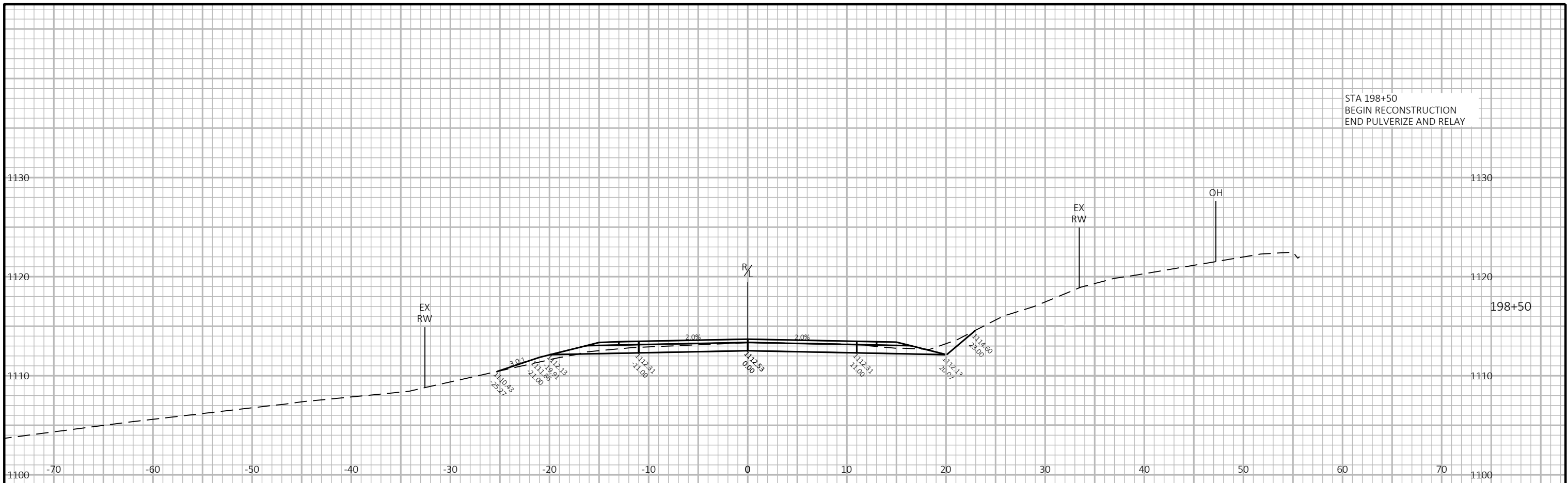

STA 198+50
 BEGIN RECONSTRUCTION
 END PULVERIZE AND RELAY

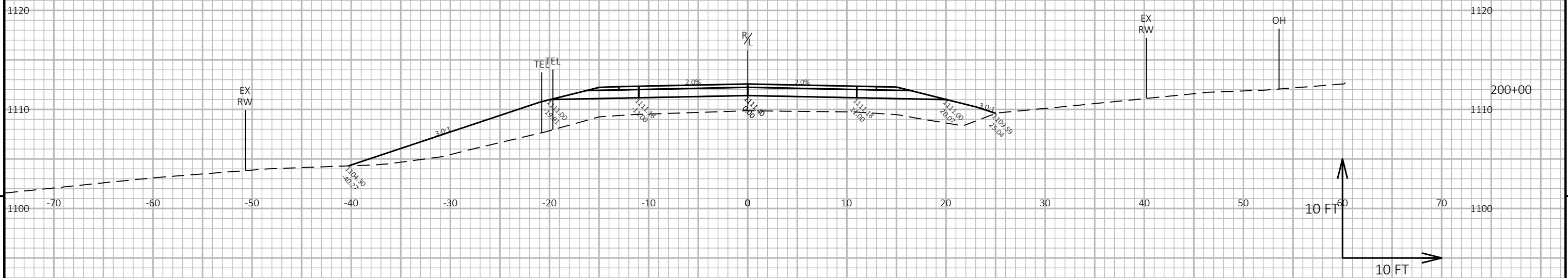

PROJECT NO: 7823-07-73	HWY: CTH D	COUNTY: EAU CLAIRE	CROSS SECTIONS: CTH D	SHEET	E
------------------------	------------	--------------------	-----------------------	-------	---

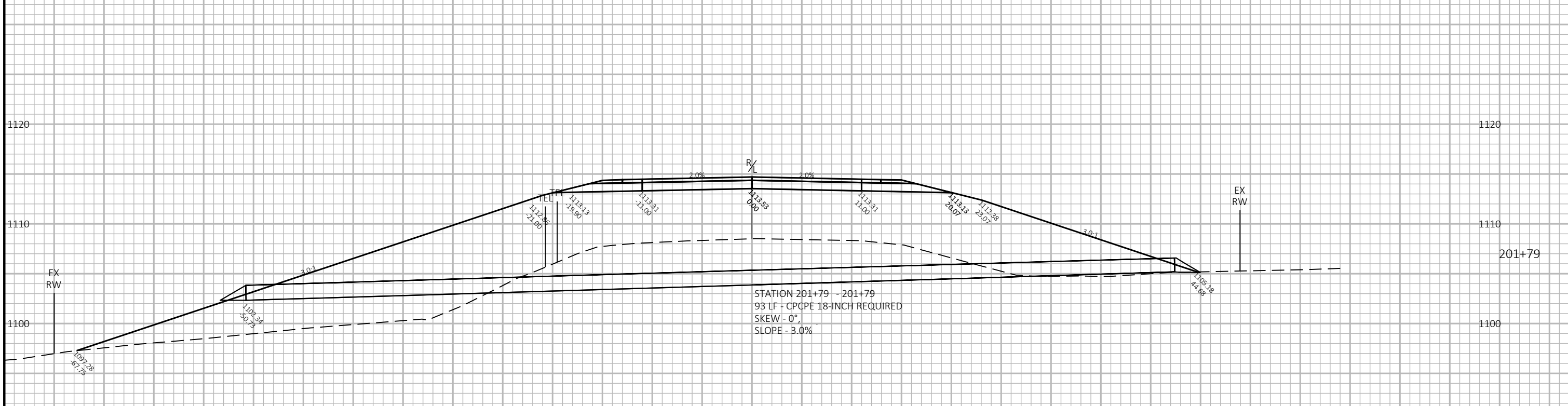
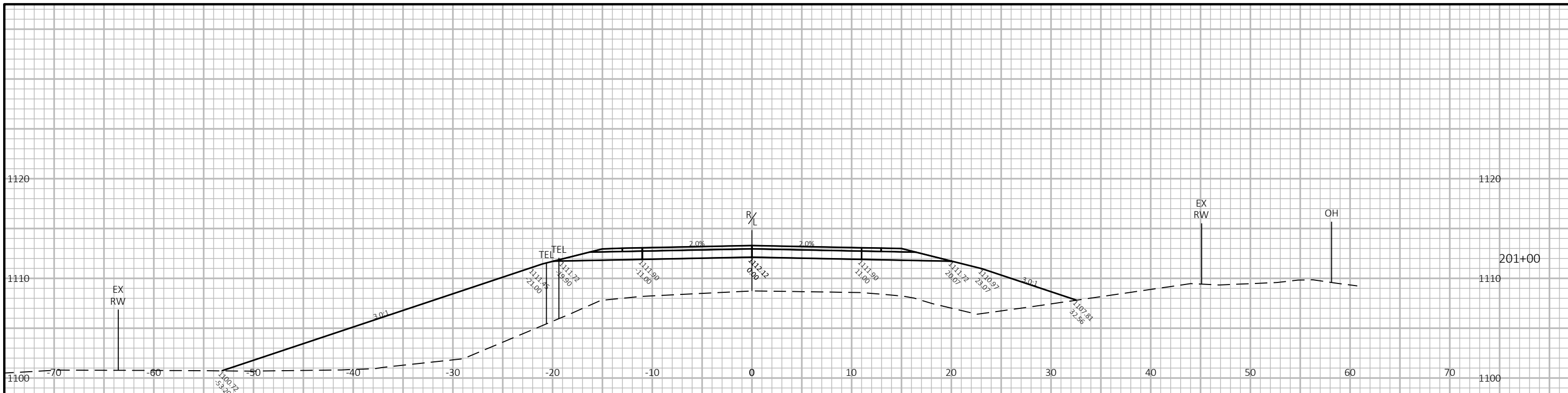

STATION 201+79 - 201+79
 93 LF - CPCPE 18-INCH REQUIRED
 SKEW - 0°
 SLOPE - 3.0%

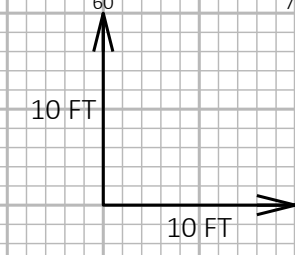

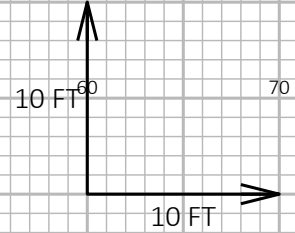
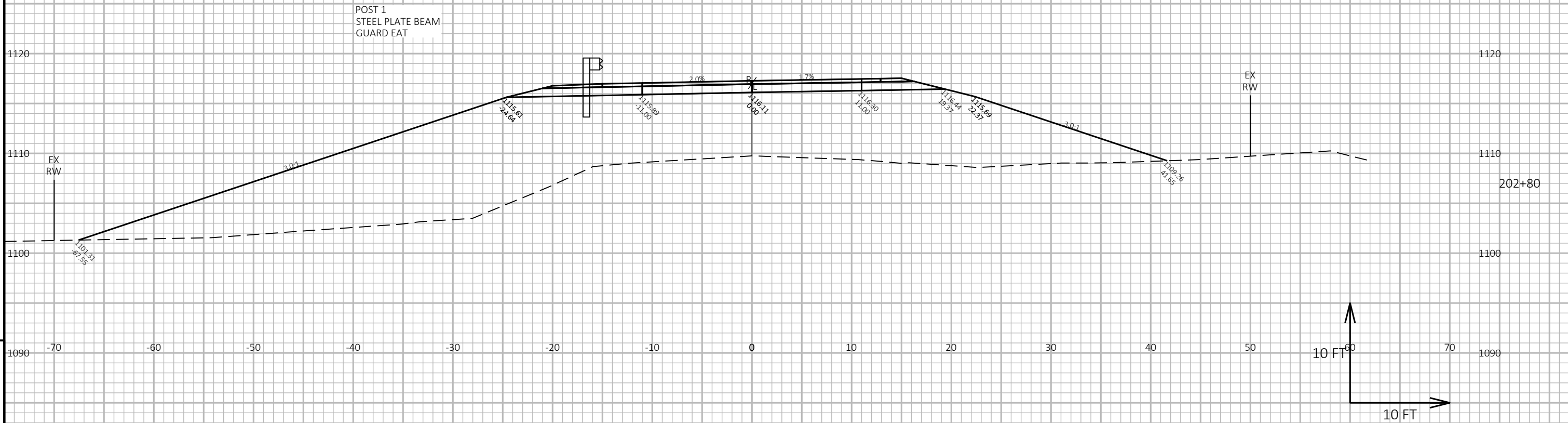
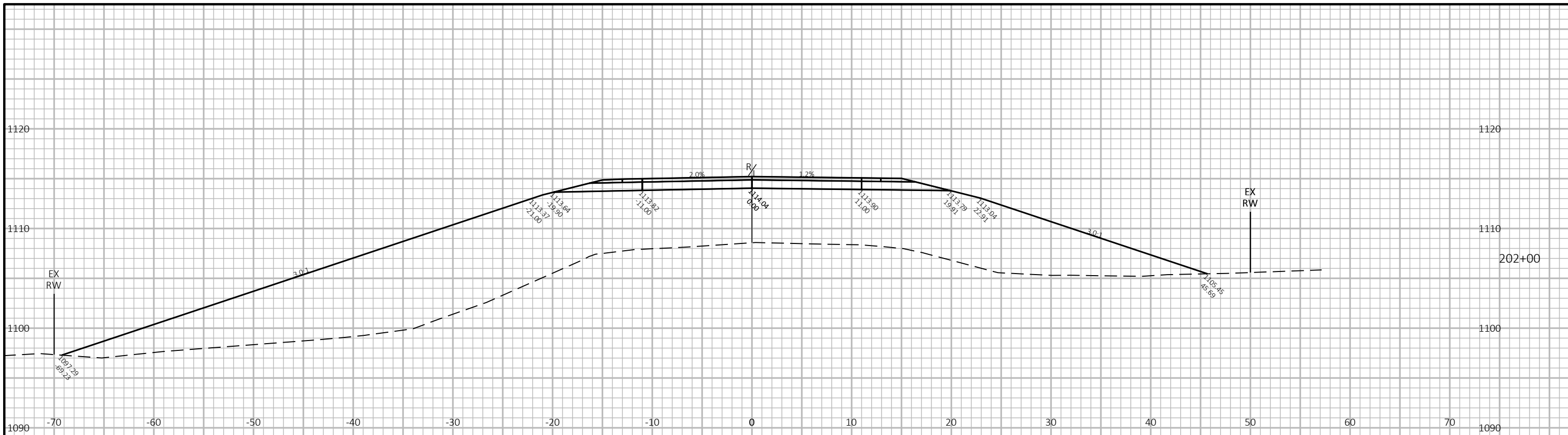

PROJECT NO: 7823-07-73	HWY: CTH D	COUNTY: EAU CLAIRE	CROSS SECTIONS: CTH D	SHEET	E
------------------------	------------	--------------------	-----------------------	-------	---

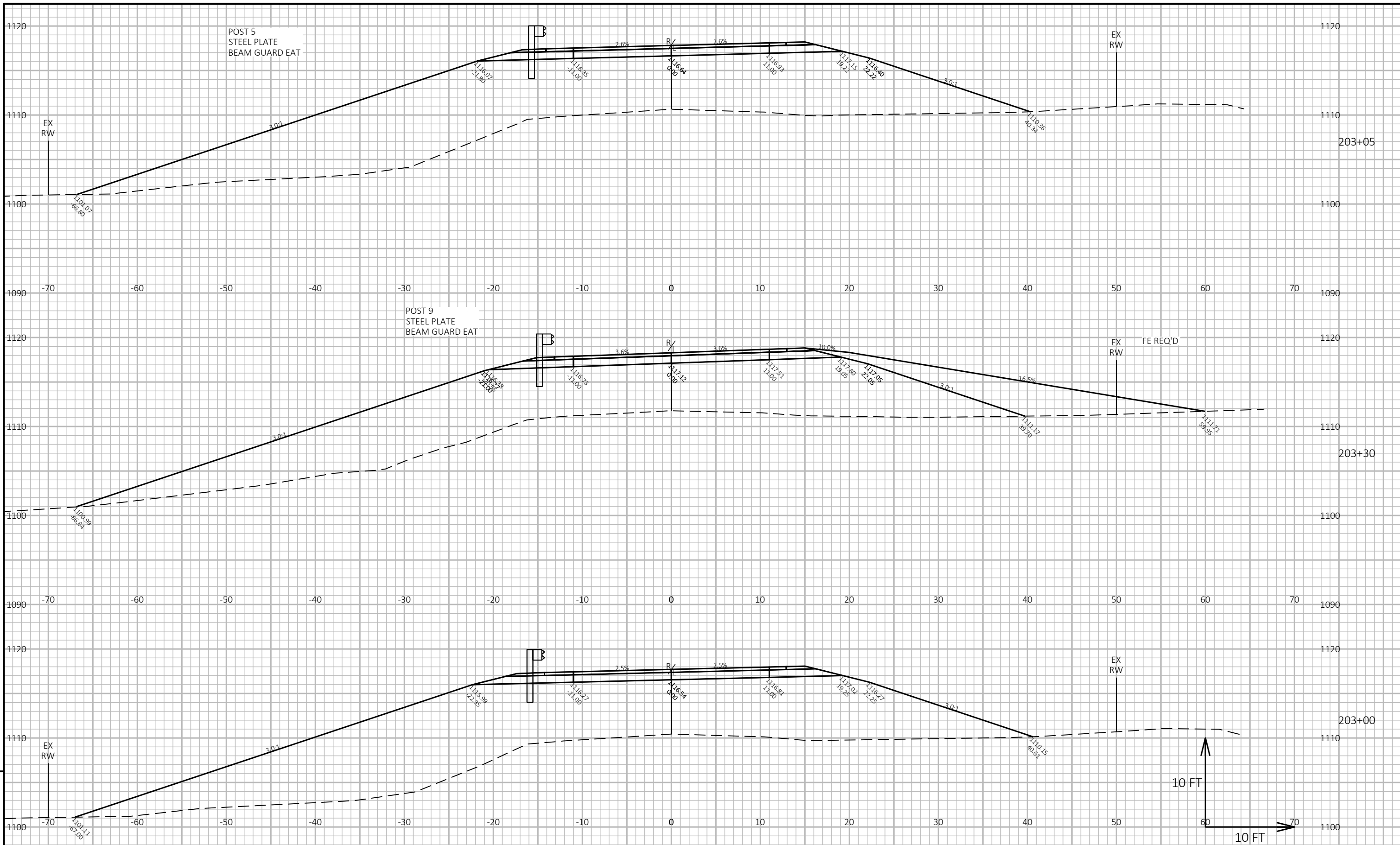

PROJECT NO: 7823-07-73

HWY: CTH D

COUNTY: EAU CLAIRE

CROSS SECTIONS: CTH D

SHEET

E

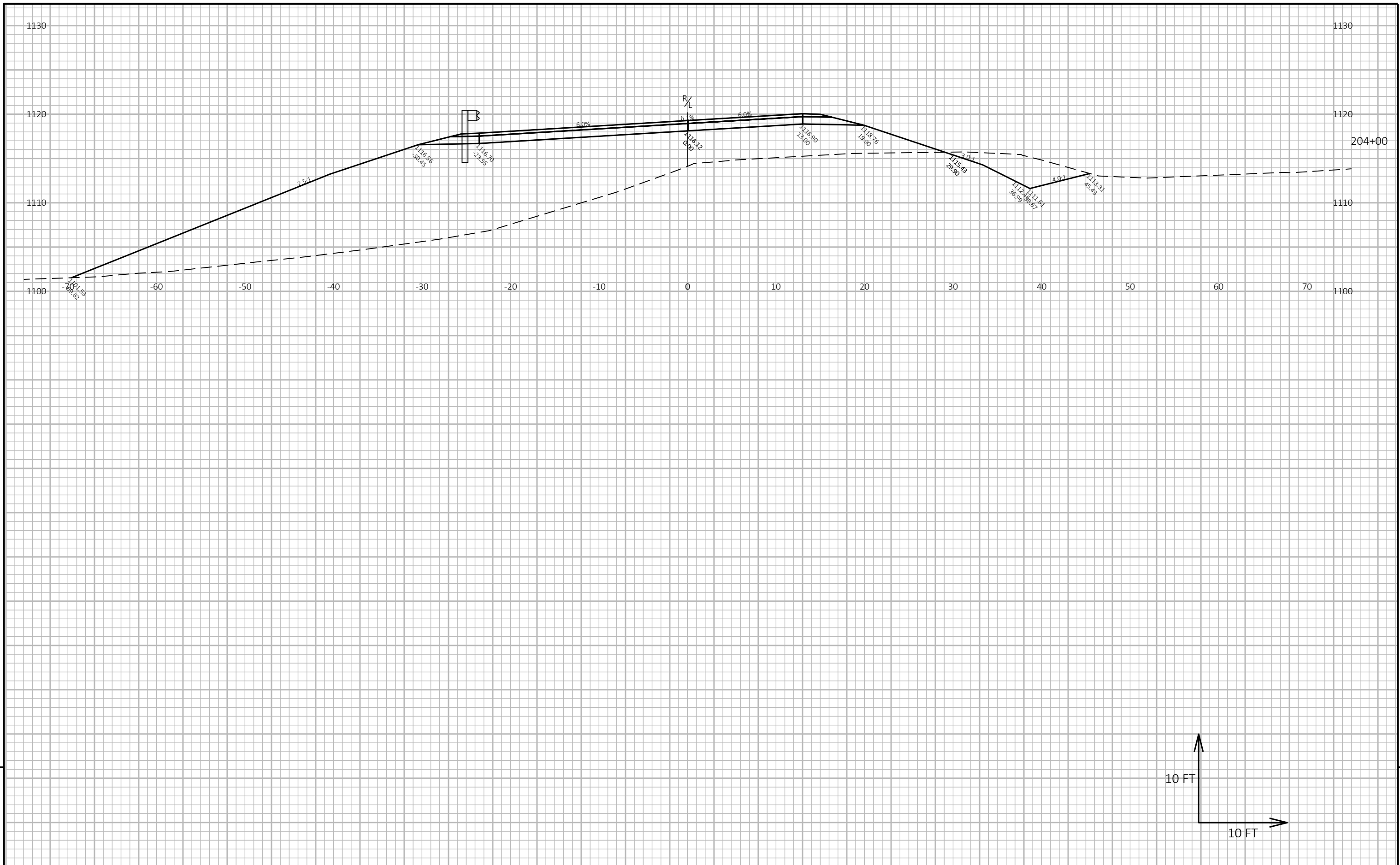

9

9

PROJECT NO: 7823-07-73 HWY: CTH D COUNTY: EAU CLAIRE CROSS SECTIONS: CTH D SHEET E

FILE NAME : C:\OD\CORRE, INC\PROJECTS - DOCUMENTS\WI - NW REGION\7823-07-03_EAU CLAIRE CO_CTH D\500_CADD\501_C3D_2018\78230703\SHEETSPLAN\090201-XS.DWG PLOT DATE : 2/18/2022 11:35 AM PLOT BY : BOBBY JONES PLOT NAME : PLOT SCALE : 1 IN:10 FT HORZ. / 1 IN:10 FT VERT. WISDOT/CADD SHEET 49

LAYOUT NAME - 090211-xs

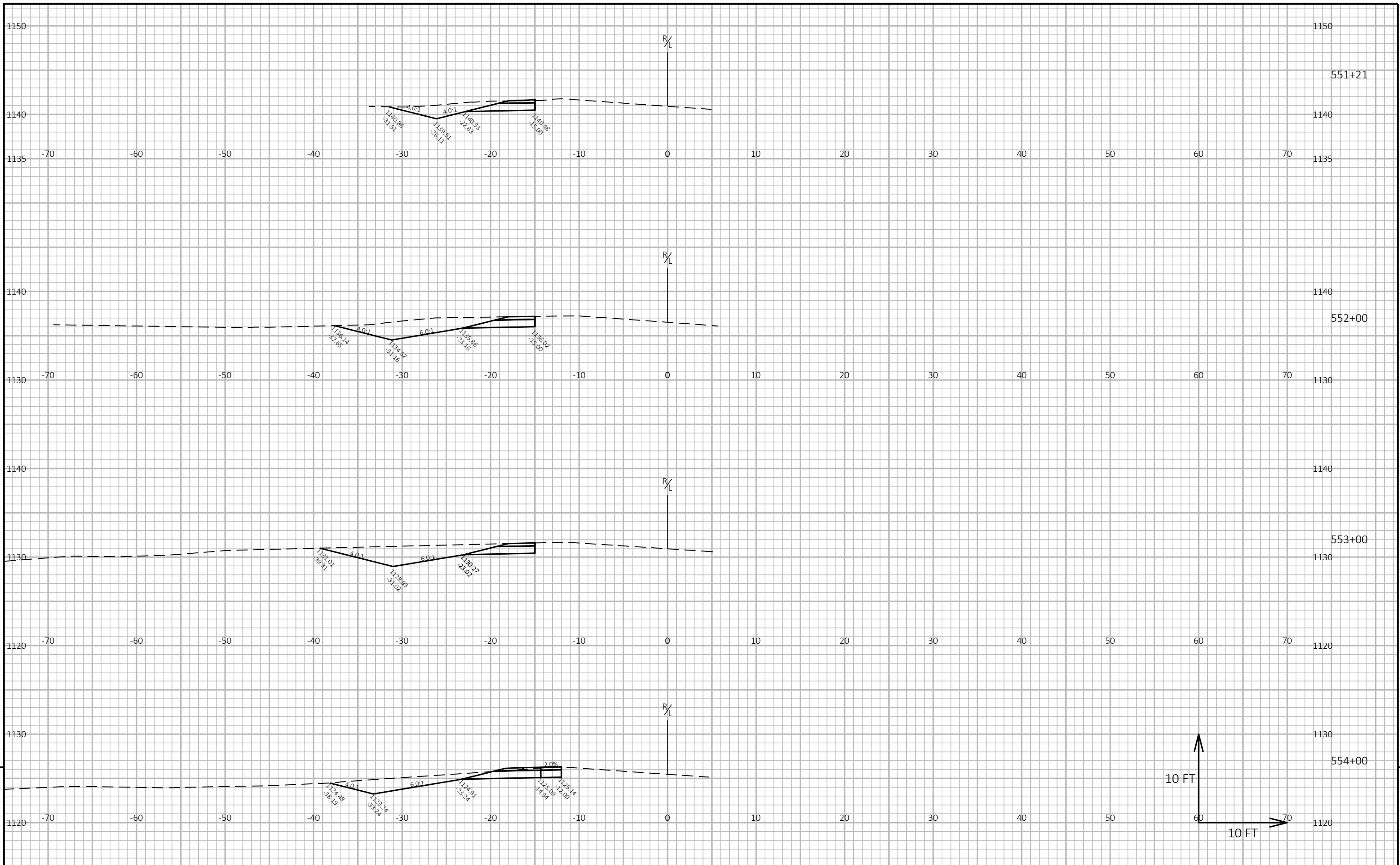

9

9

PROJECT NO: 7823-07-73 HWY: CTH D COUNTY: EAU CLAIRE CROSS SECTIONS: STH 27 INTERSECTION SHEET E

FILE NAME : C:\OD\CORRE, INC\PROJECTS - DOCUMENTS\WI - NW REGION\7823-07-03_EAU CLAIRE CO_CTH D\500_CADD\501_C3D_2018\78230703\SHEETSPLAN\090201-XS.DWG PLOT DATE : 2/18/2022 11:35 AM PLOT BY : BOBBY JONES PLOT NAME : PLOT SCALE : 1 IN:10 FT HORZ. / 1 IN:10 FT VERT. WISDOT/CADD SHEET 49

LAYOUT NAME - 090209-xs

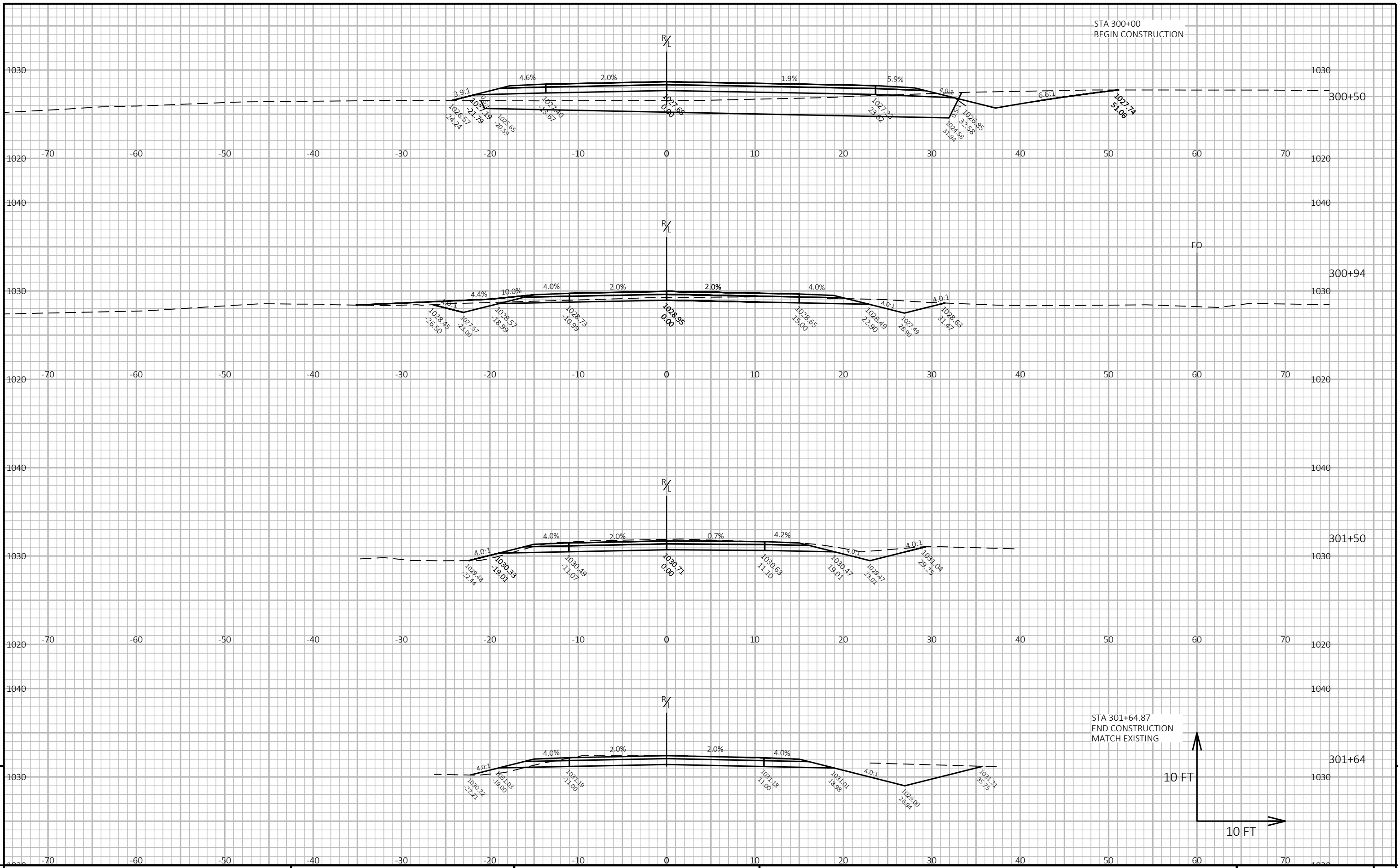

STA 300+00
BEGIN CONSTRUCTION

STA 301+64.87
END CONSTRUCTION
MATCH EXISTING

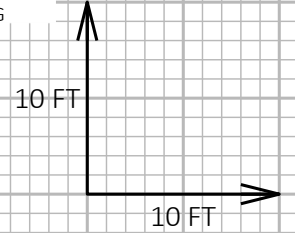

Notes



Wisconsin Department of Transportation

Dedicated people creating transportation solutions through innovation and exceptional service.

<http://www.dot.wisconsin.gov>