

ORDER OF SHEETS

Section No.	1	Title
Section No.	2	Typical Sections and Details
Section No.	3	Estimate of Quantities
Section No.	3	Miscellaneous Quantities
Section No.	4	Right of Way Plat
Section No.	5	Plan and Profile
Section No.	6	Standard Detail Drawings
Section No.	7	Sign Plates
Section No.	8	Structure Plans
Section No.	9	Computer Earthwork Data
Section No.	9	Cross Sections

TOTAL SHEETS = 182

34

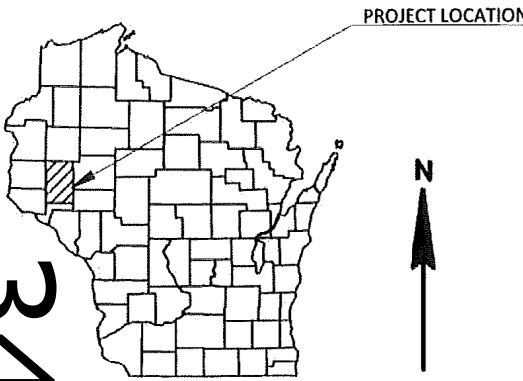

STATE OF WISCONSIN
DEPARTMENT OF TRANSPORTATION

PLAN OF PROPOSED IMPROVEMENT

CARYVILLE - CTH M
CTH HH TO CTH M
CTH H
DUNN COUNTY

STATE PROJECT NUMBER
7880-07-73

STATE PROJECT	FEDERAL PROJECT	
	PROJECT	CONTRACT
7880-07-73	WISC 2022260	1

DESIGN DESIGNATION

A.A.D.T. (2022)	=	752
A.A.D.T. (2042)	=	782
D.H.V.	=	N/A
D.D.	=	50/50
T.	=	5.6%
DESIGN SPEED	=	55 MPH
ESALS	=	88,000

CONVENTIONAL SYMBOLS

PLAN	
CORPORATE LIMITS	
PROPERTY LINE	
LOT LINE	
LIMITED HIGHWAY EASEMENT	
EXISTING RIGHT OF WAY	
PROPOSED OR NEW R/W LINE	
SLOPE INTERCEPT	
REFERENCE LINE	
EXISTING CULVERT	
PROPOSED CULVERT (Box or Pipe)	
COMBUSTIBLE FLUIDS	
MARSH AREA	
WOODED OR SHRUB AREA	

PROFILE

GRADE LINE	
ORIGINAL GROUND	
MARSH OR ROCK PROFILE (To be noted as such)	
SPECIAL DITCH	
GRADE ELEVATION	
CULVERT (Profile View)	
UTILITIES	
ELECTRIC	
FIBER OPTIC	
GAS	
OVERHEAD	
SANITARY SEWER	
STORM SEWER	
TELEPHONE	
WATER	
UTILITY PEDESTAL	
POWER POLE	
TELEPHONE POLE	

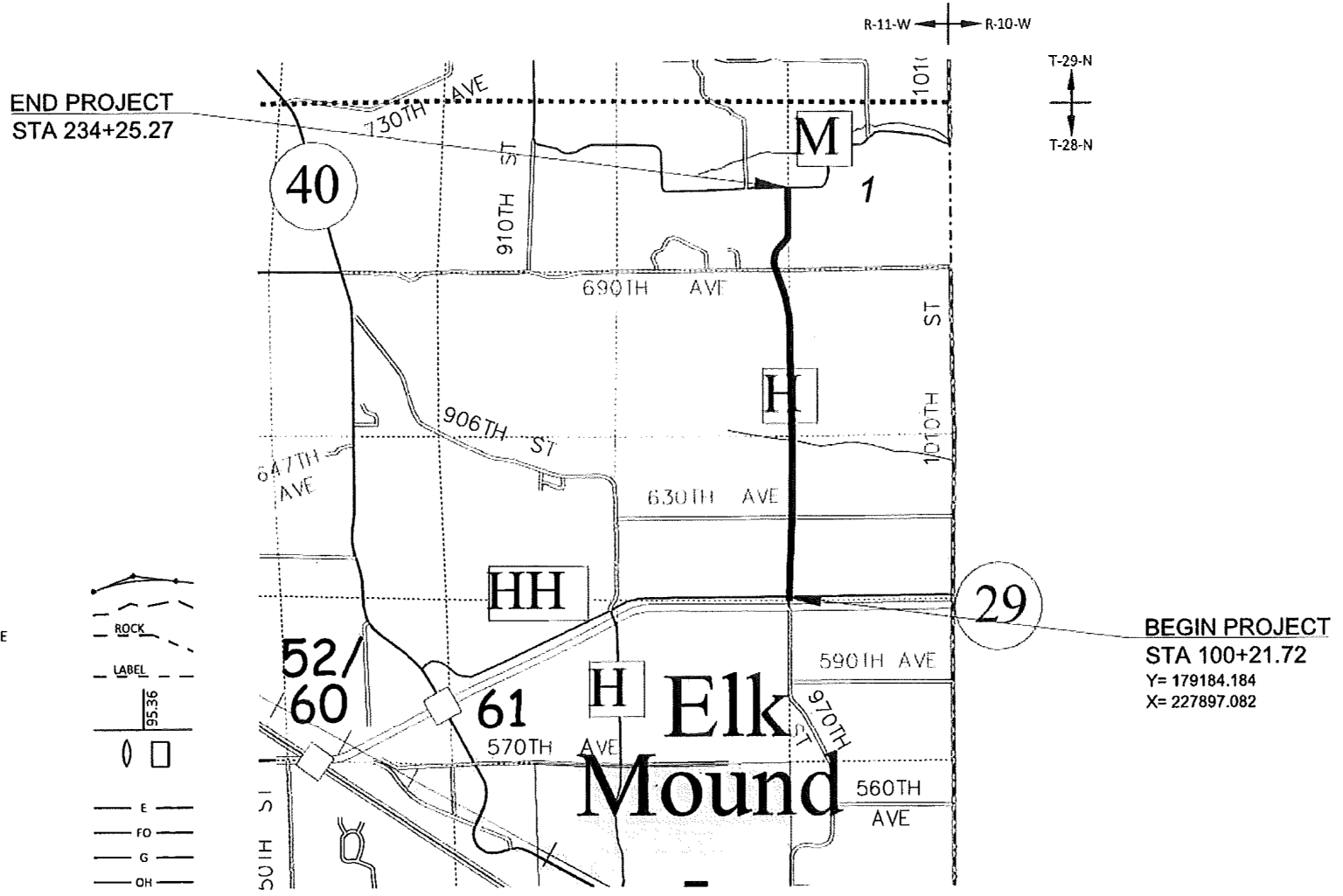
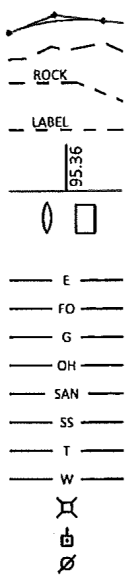

HORIZONTAL POSITIONS SHOWN ON THIS PLAN ARE WISCONSIN COORDINATE REFERENCE SYSTEM (WISCRS), DUNN COUNTY, NAD83 (2011), IN U.S. SURVEY FEET. POSITIONS SHOWN ARE GRID COORDINATES, GRID BEARINGS, AND GRID DISTANCES. GRID DISTANCES ARE THE SAME AS GROUND DISTANCES. ELEVATIONS ARE REFERENCED TO NAVD 88 (2012). GPS DERIVED ELEVATIONS ARE BASED ON GEOID 12A.

ACCEPTED FOR
DUNN COUNTY

Date: 10/11/2021

(Signature)
ENGINEER SUPERINTENDENT
(Title of Official)

ORIGINAL PLANS PREPARED BY

CORRE
ENGINEERING

WISCONSIN PROFESSIONAL ENGINEER

CHAD HALAMA
E-33518
MENOMONIE WI

DATE: 10/17/21
(Signature)
(Professional Engineer Signature)

STATE OF WISCONSIN
DEPARTMENT OF TRANSPORTATION

PREPARED BY

Surveyor	CORRE INC
Designer	CORRE INC
Project Manager	MATTHEW THORNSEN, PE
Regional Examiner	TOU YANG, PE
Regional Supervisor	TYLER RONGSTAD, PE

APPROVED FOR THE DEPARTMENT

DATE: 10/15/2021
(Signature)

E

GENERAL NOTES

WHEN THE QUANTITY OF BASE AGGREGATE OR ASPHALTIC SURFACE IS MEASURED FOR PAYMENT BY THE TON OR CUBIC YARD, THE DEPTH OR THICKNESS OF THE LAYER SHOWN ON THE PLANS IS APPROXIMATE AND THE ACTUAL THICKNESS WILL DEPEND ON THE DISTRIBUTION OF THE MATERIAL AS DIRECTED BY THE ENGINEER.

THE LOCATION OF EXISTING AND PROPOSED UTILITY INSTALLATIONS AS SHOWN ON THE PLANS IS APPROXIMATE. THERE MAY BE OTHER UTILITY INSTALLATIONS WITHIN THE PROJECT AREA THAT ARE NOT SHOWN.

NO TREES OR SHRUBS ARE TO BE REMOVED WITHOUT THE APPROVAL OF THE ENGINEER.

CURVE DATA IS BASED ON THE ARC DEFINITION.

THE EXACT LOCATION OF THE EROSION CONTROL DEVICES SHALL BE DETERMINED IN THE FIELD.

DISTURBED AREAS WITHIN THE RIGHT-OF-WAY, EXCEPT THE AREAS WITHIN THE FINISHED SHOULDER POINTS, ARE TO BE 4-INCH SALVAGED TOPSOILED, FERTILIZED, SEEDED, AND EMATTED OR MULCHED.

SEED, FERTILIZE, EMAT OR MULCH, ALL SALVAGED TOPSOILED AREAS WITHIN 7 DAYS OF COMPLETING GRADING WORK.

EXCAVATION BELOW SUBGRADE (EBS) IS NOT USED TO BALANCE EARTHWORK. EBS IS MEASURED AND PAID FOR AS COMMON EXCAVATION. EXACT LOCATIONS OF EBS WILL BE DETERMINED BY THE ENGINEER IN THE FIELD.

THE LOCATIONS OF ROCK AS SHOWN ON THE PLANS ARE APPROXIMATE AND ADDITIONAL ROCK MAY BE ENCOUNTERED.

4-INCH BASE AGGREGATE DENSE 1 1/4-INCH SHALL BE PLACED ON ROADWAY TOP PRIOR TO PULVERIZING OPERATIONS.

A VERTICAL SAWCUT SHALL BE MADE THROUGH EXISTING ASPHALT DRIVEWAYS AND PAVEMENTS AT REMOVAL LIMITS.

4 INCH HMA PAVEMENT SHALL BE CONSTRUCTED WITH A 2 INCH 4 LT 58-34 S UPPER LAYER AND A 2 INCH 3 LT 58-28 S LOWER LAYER.

HMA PAVEMENT WEIGHT CALCULATIONS ARE BASED ON 112 LB/SY/IN.

RADIUS POINTS ARE SHOWN TO CURB FLAG.

CROSS DRAIN PIPE LOCATIONS AND ELEVATIONS AS SHOWN ON THE CROSS SECTIONS SHALL BE FIELD VERIFIED AND ADJUSTED TO FIT FIELD CONDITIONS.

6-INCH PULVERIZE AND RELAY SHALL BE PERFORMED FROM THE TOP OF EXISTING ASPHALTIC PAVEMENT.

UTILITY CONTACTS

BLOOMER TELEPHONE COMPANY
 TRAVIS MCFARLANE
 1120 15TH AVE
 BLOOMER, WI 54724-1697
 (715) 568-4830
 (715) 993-4460 (CELL)
 TRAVIS.MCFARLANE@BLOOMER.NET

XCEL ENERGY ELECTRIC TRANSMISSION
 MITCHELL DIENGER
 414 NICOLLET MALL
 5TH FLOOR
 MINNEAPOLIS, MN 55401
 (612) 321-3109
 MITCHELL.A.DIENGER@XCELENERGY.COM

LUMEN
 KYLE SCHLAMPP
 20 S WILSON AVE
 RICE LAKE, WI 54868
 (715) 475-2029
 (715) 292-0082 (CELL)
 KYLE.SCHLAMPP@LUMEN.COM

DAIRYLAND POWER COOPERATIVE
 ROB MALY
 3200 EAST AVE S
 LA CROSSE, WI 54602
 (608) 787-1427
 (608) 518-2633 (CELL)
 ROB.MALY@DAIRYLANDPOWER.COM

DUNN ENERGY COOPERATIVE
 MIKE ANDRASCHKO
 PO BOX 220
 MENOMONIE, WI 54751
 (715) 232-6240
 (715) 231-0214 (CELL)
 MANDRA@DUNNENERGY.COM

DNR CONTACT

LEAH NICOL
 DNR WEST CENTRAL REGION HQ
 1300 W CLAIREMONT AVE
 EAU CLAIRE, WI 54701
 (715) 934-9014
 LEAH.NICOL@WISCONSIN.GOV

CONSULTANT CONTACT

CORRE, INC.
 1802 WARDEN STREET
 EAU CLAIRE, WI 54703
 CHAD HALAMA, PE
 715-619-8345
 CHALAMA@CORREINC.COM



ORDER OF SECTION 2 SHEETS

- PROJECT OVERVIEW
- TYPICAL SECTIONS
- CONSTRUCTION DETAILS
- PLAN & GRADING DETAILS
- EROSION CONTROL
- PERMANENT SIGNING
- TRAFFIC CONTROL
- DETOUR PLAN

RUNOFF COEFFICIENT TABLE

	HYDROLOGIC SOIL GROUP											
	A			B			C			D		
	SLOPE RANGE (PERCENT)			SLOPE RANGE (PERCENT)			SLOPE RANGE (PERCENT)			SLOPE RANGE (PERCENT)		
LAND USE:	0 - 2	2 - 6	6 & OVER	0 - 2	2 - 6	6 & OVER	0 - 2	2 - 6	6 & OVER	0 - 2	2 - 6	6 & OVER
ROW CROPS	.08 .22	.16 .30	.22 .38	.12 .26	.20 .34	.27 .44	.15 .30	.24 .37	.33 .50	.19 .34	.28 .41	.38 .56
MEDIAN STRIP-TURF	.19 .24	.20 .26	.24 .30	.19 .25	.22 .28	.26 .33	.20 .26	.23 .30	.30 .37	.20 .27	.25 .32	.30 .40
SIDE SLOPE-TURF			.25 .32			.27 .34			.28 .36			.30 .38
PAVEMENT:												
ASPHALT	.70 - .95											
CONCRETE	.80 - .95											
BRICK	.70 - .80											
DRIVES, WALKS	.75 - .85											
ROOFS	.75 - .95											
GRAVEL ROADS, SHOULDERS	.40 - .60											

TOTAL PROJECT AREA = 20.31 ACRES
 TOTAL AREA EXPECTED TO BE DISTURBED BY CONSTRUCTION ACTIVITIES = 8.79 ACRES



PROJECT NO: 7880-07-73	HWY: CTH H	COUNTY: DUNN	PROJECT OVERVIEW	SHEET	E
------------------------	------------	--------------	------------------	-------	---

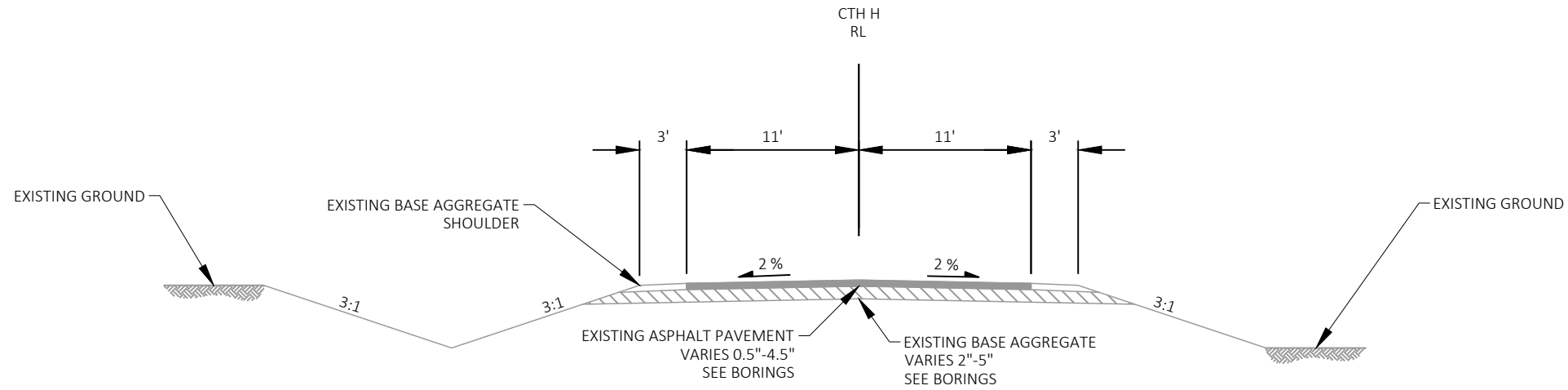

EXISTING TYPICAL SECTION

STA 100+21.72 - 234+25.27
630TH AVE

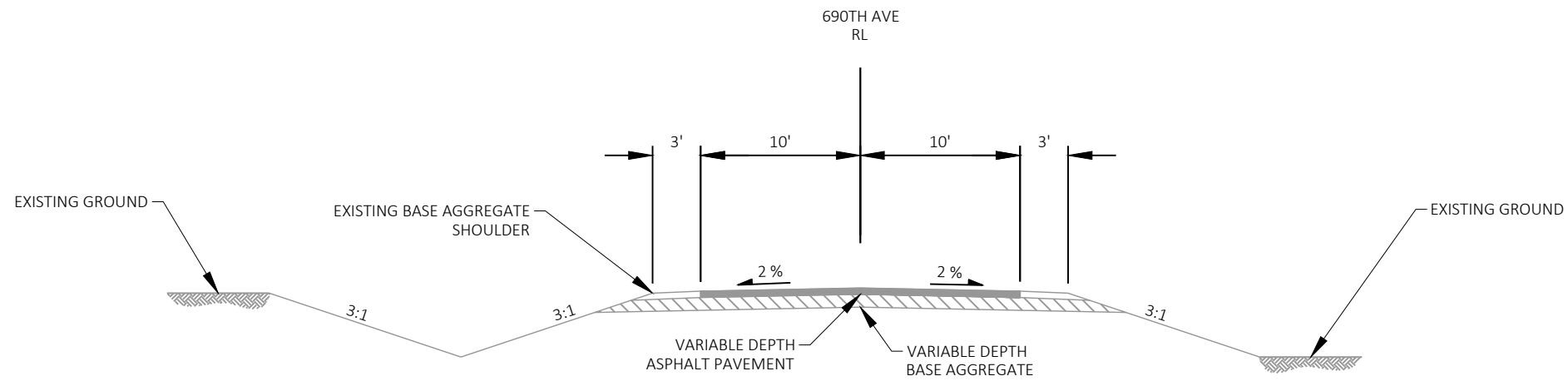

EXISTING TYPICAL SECTION

690TH AVE

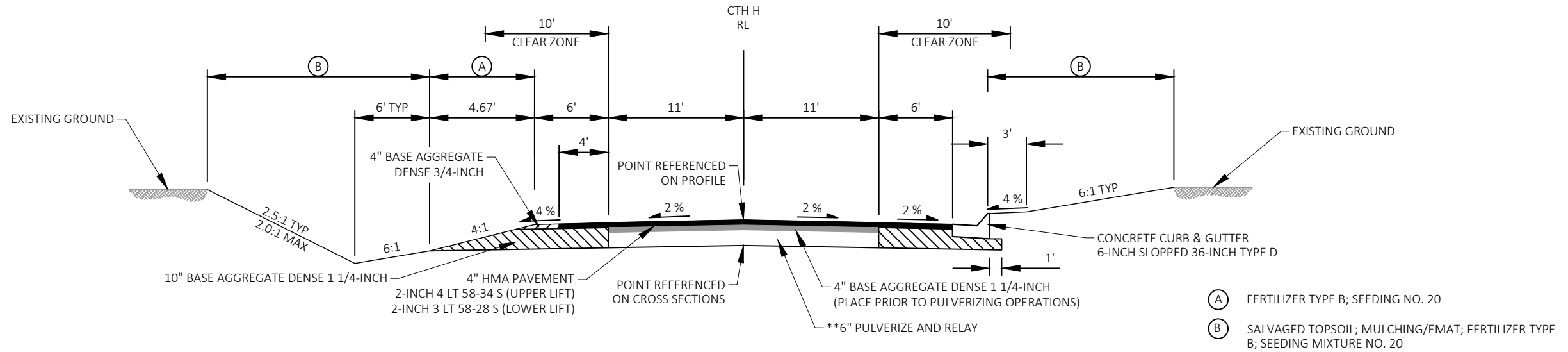

FINISHED TYPICAL SECTION - CURB & GUTTER RT
STA 100+21.72 - 102+25

**PULVERIZE 6-INCH BELOW EXISTING ASPHALT SURFACE

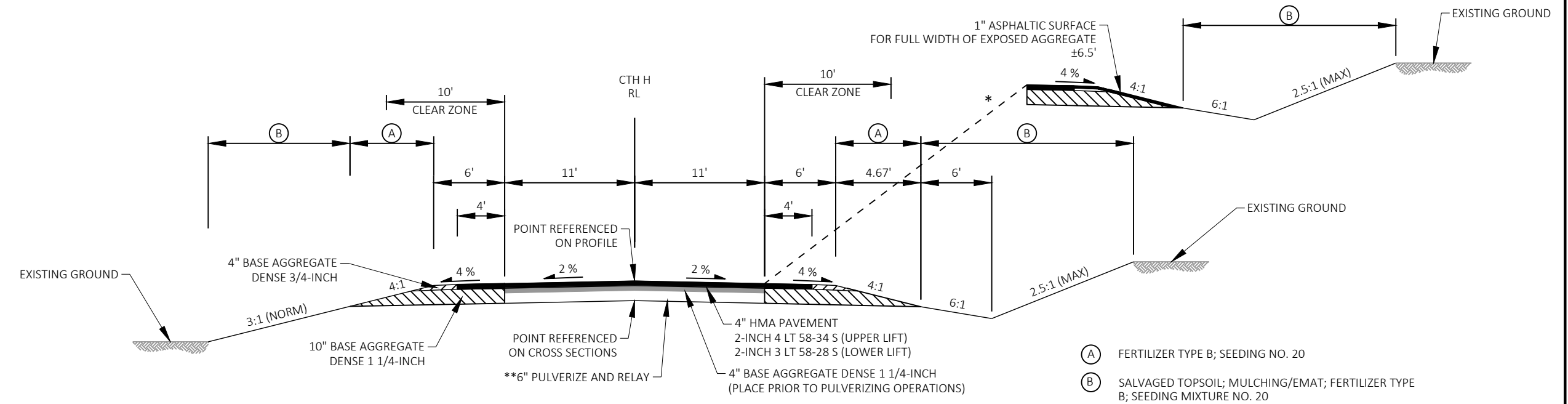

FINISHED TYPICAL SECTION - PULVERIZE AND RELAY

STA 102+25 - 117+00
STA 122+75 - 123+00
STA 136+35 - 196+50
STA 202+50 - 207+00
* STA 207+00 - 214+00
STA 214+00 - 234+25.27

**PULVERIZE 6-INCH BELOW EXISTING ASPHALT SURFACE

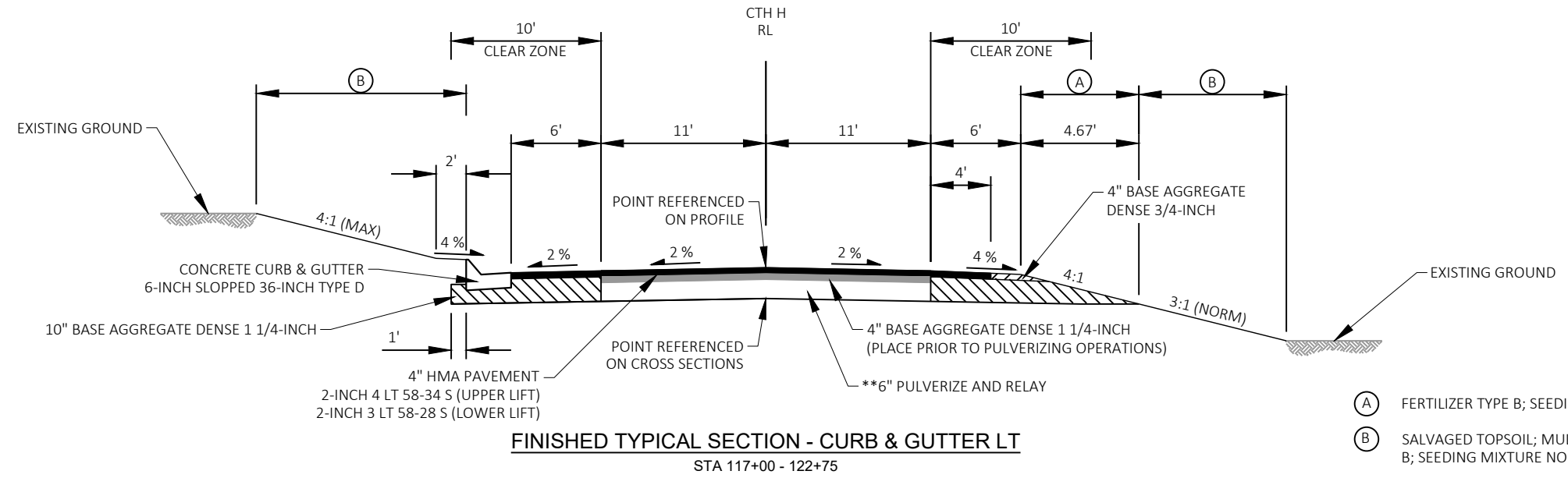

- (A) FERTILIZER TYPE B; SEEDING NO. 20
 - (B) SALVAGED TOPSOIL; MULCHING/EMAT; FERTILIZER TYPE B; SEEDING MIXTURE NO. 20
- **PULVERIZE 6-INCH BELOW EXISTING ASPHALT SURFACE

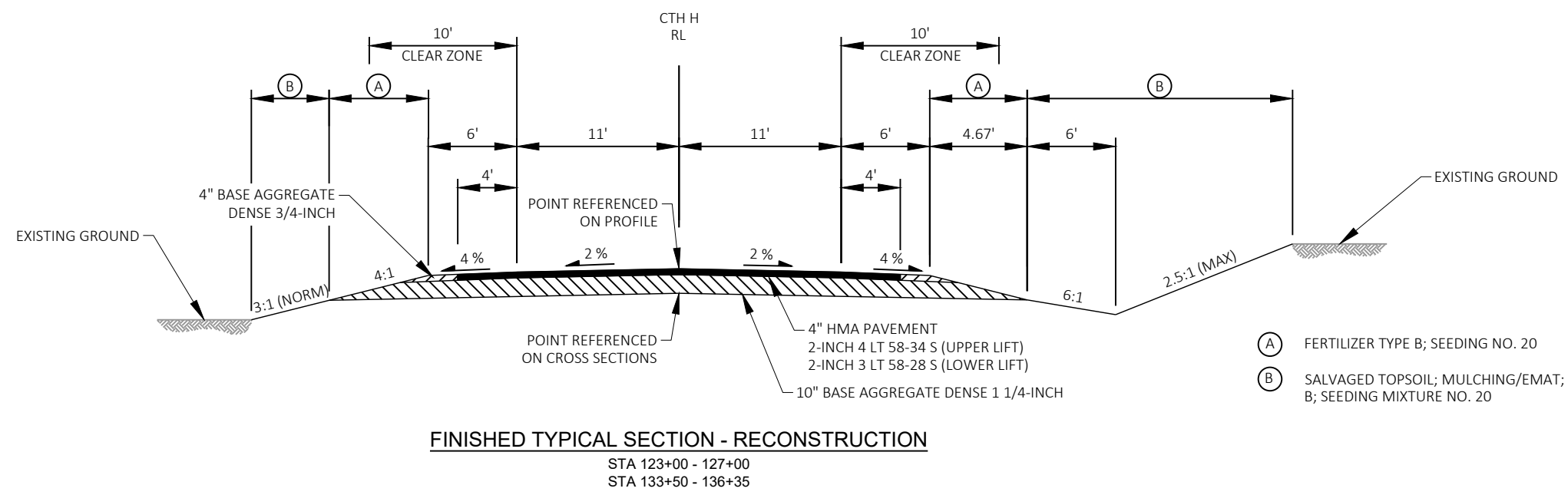

- (A) FERTILIZER TYPE B; SEEDING NO. 20
- (B) SALVAGED TOPSOIL; MULCHING/EMAT; FERTILIZER TYPE B; SEEDING MIXTURE NO. 20

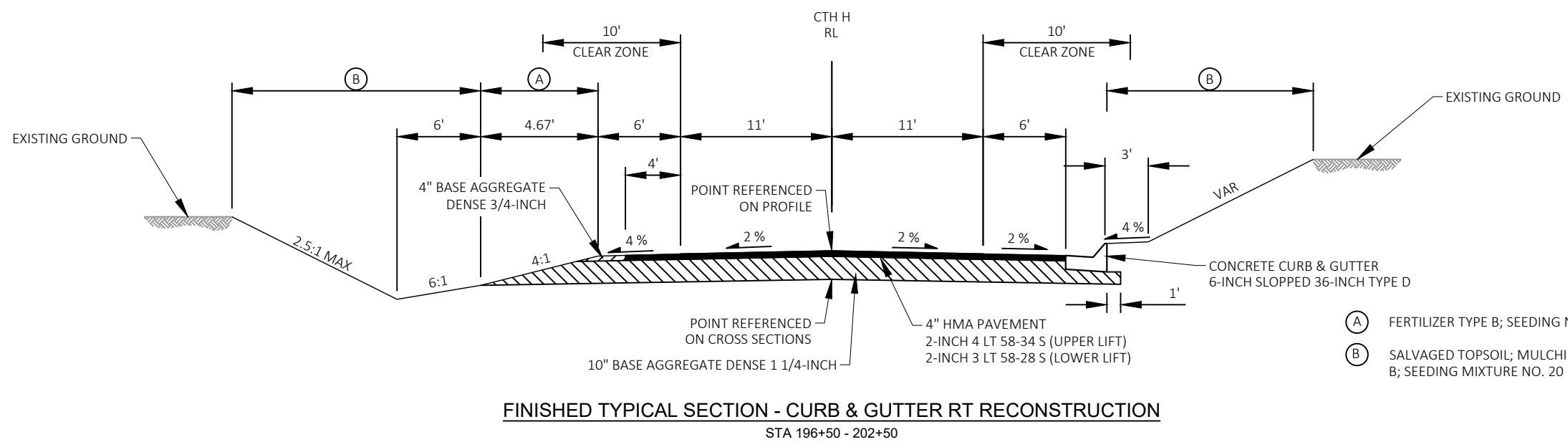
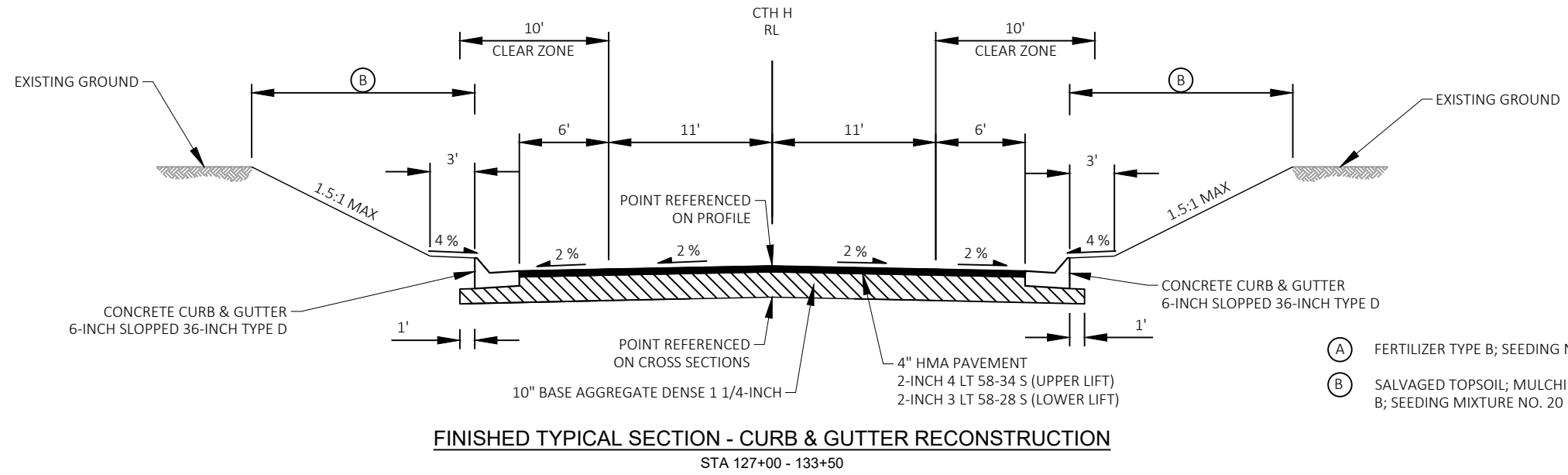

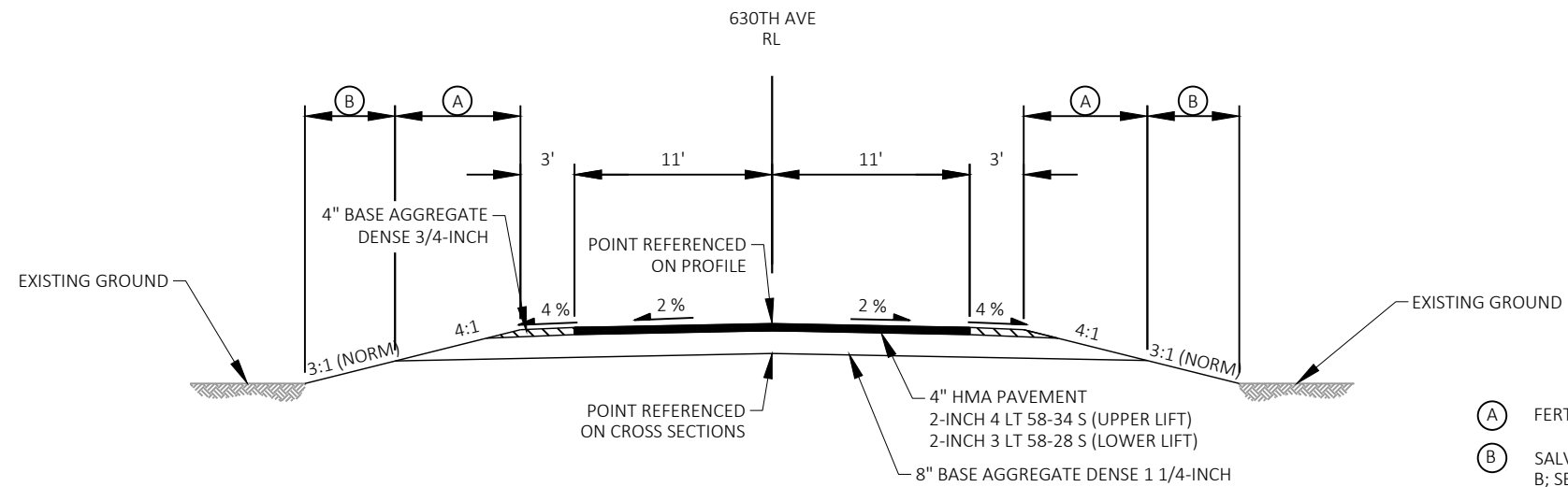

FINISHED TYPICAL SECTION - 630TH AVE
 STA 498+54 - 501+75

- (A) FERTILIZER TYPE B; SEEDING NO. 20
- (B) SALVAGED TOPSOIL; MULCHING/EMAT; FERTILIZER TYPE B; SEEDING MIXTURE NO. 20

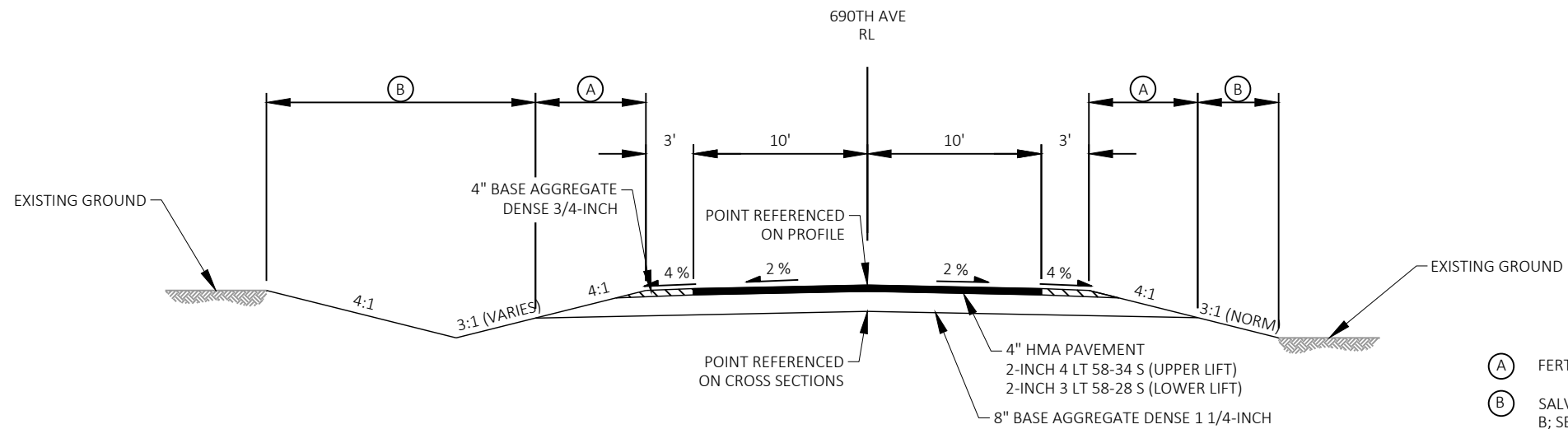

FINISHED TYPICAL SECTION - 690TH AVE
 STA 798+74 - 801+03

- (A) FERTILIZER TYPE B; SEEDING NO. 20
- (B) SALVAGED TOPSOIL; MULCHING/EMAT; FERTILIZER TYPE B; SEEDING MIXTURE NO. 20

CTH H - DUNN CO					
SUPERELEVATION TRANS. POINTS		RATF			
LOCATION	STATION	LEFT OF CROWNLIN		RIGHT OF CROWNLIN	
		LEFT SHOULDER	LEFT LANE	RIGHT LANE	RIGHT SHOULDER
CURVE 190+55.62 - 193+64.57					
NORMAL CROWN	189+10	4.00%	2.00%	2.00%	4.00%
LEVEL CROWN	189+61	-4.00%	-2.00%	0.00%	0.00%
REVERSE CROWN	190+12	-4.00%	-2.00%	2.00%	2.00%
FULL SUPERELEVATION	191+04	-5.60%	-5.60%	5.60%	5.60%
FULL SUPERELEVATION	193+17	-5.60%	-5.60%	5.60%	5.60%
REVERSE CROWN	194+09	-4.00%	-2.00%	2.00%	2.00%
LEVEL CROWN	194+60	-4.00%	-2.00%	0.00%	0.00%
NORMAL CROWN	195+11	-4.00%	-2.00%	-2.00%	-4.00%
CURVE 207+76.27 - 210+06.04					
NORMAL CROWN	206+23	-4.00%	-2.00%	-2.00%	-4.00%
LEVEL CROWN	206+74	0.00%	0.00%	2.00%	4.00%
REVERSE CROWN	207+25	2.00%	2.00%	-2.00%	-4.00%
FULL SUPERELEVATION	208+27	6.00%	6.00%	-6.00%	-6.00%
CURVE 210+06.04 - 212+31.02					
FULL SUPERELEVATION	210+06	6.00%	6.00%	-6.00%	-6.00%
FULL SUPERELEVATION	212+31	6.00%	6.00%	-6.00%	-6.00%
CURVE 212+31.02 - 214+65.54					
FULL SUPERELEVATION	212+31	6.00%	6.00%	-6.00%	-6.00%
FULL SUPERELEVATION	214+15	6.00%	6.00%	6.00%	6.00%
LEVEL CROWN	215+68	0.00%	0.00%	0.00%	0.00%
CURVE 216+69.72 - 219+75.21					
LEVEL CROWN	215+68	0.00%	0.00%	0.00%	0.00%
FULL SUPERELEVATION	217+21	-6.00%	-6.00%	6.00%	6.00%
FULL SUPERELEVATION	219+24	-6.00%	-6.00%	6.00%	6.00%
REVERSE CROWN	220+26	-4.00%	-2.00%	2.00%	2.00%
LEVEL CROWN	220+77	-4.00%	-2.00%	0.00%	0.00%
NORMAL CROWN	221+28	-4.00%	-2.00%	-2.00%	4.00%

PAVEMENT CORE LOCATION						
CORE	STATION	OFFSET	SIDE	ASPHALT THICKNESS (IN)	BASE THICKNESS (IN)	RECYCLED THICKNESS (IN)
B-01	103+00.00	5.00'	RT	2	4	--
B-02	131+40.00	15.00'	LT	0.5	4.5	--
B-03	152+30.00	5.00'	RT	4	4.5	--
B-04	161+10.00	15.00'	LT	3	4	4
B-05	185+90.00	5.00'	RT	1	5	--
B-06	213+10.00	5.00'	LT	2	2	--
B-07	228+05.00	5.00'	RT	4.5	--	--

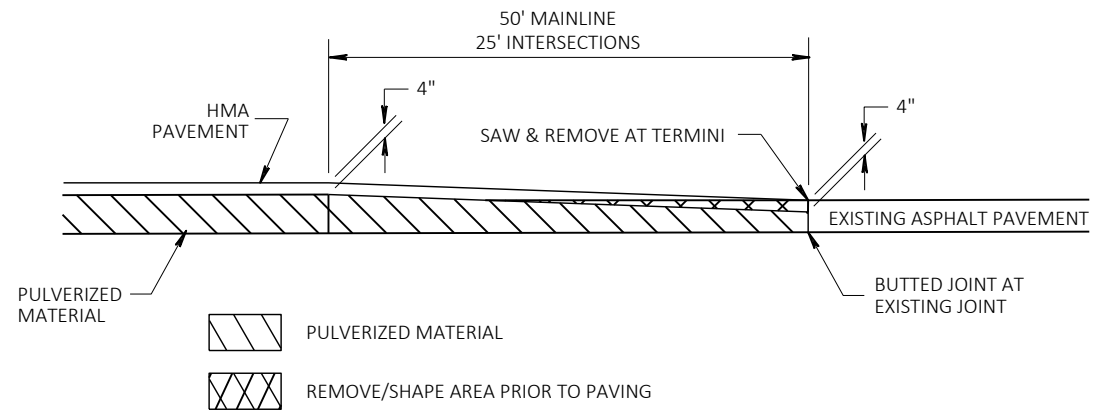

DETAIL OF BUTTED JOINT

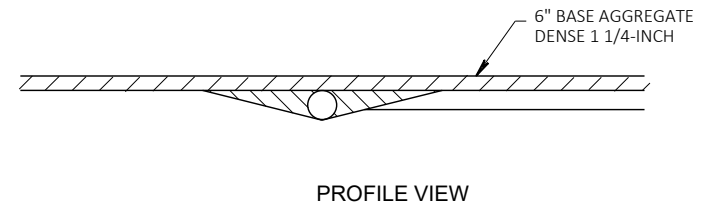
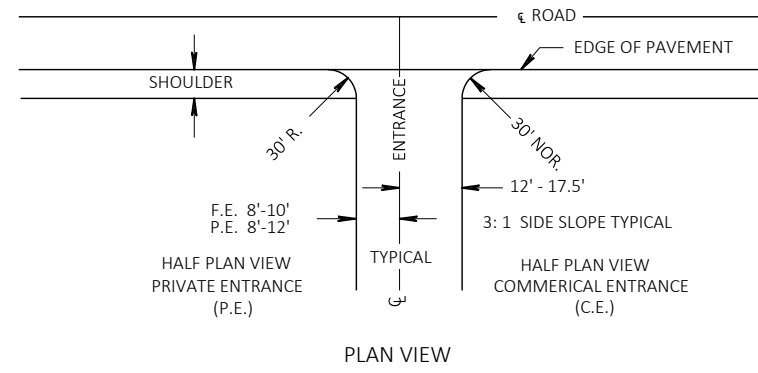

RURAL DRIVEWAY DETAIL

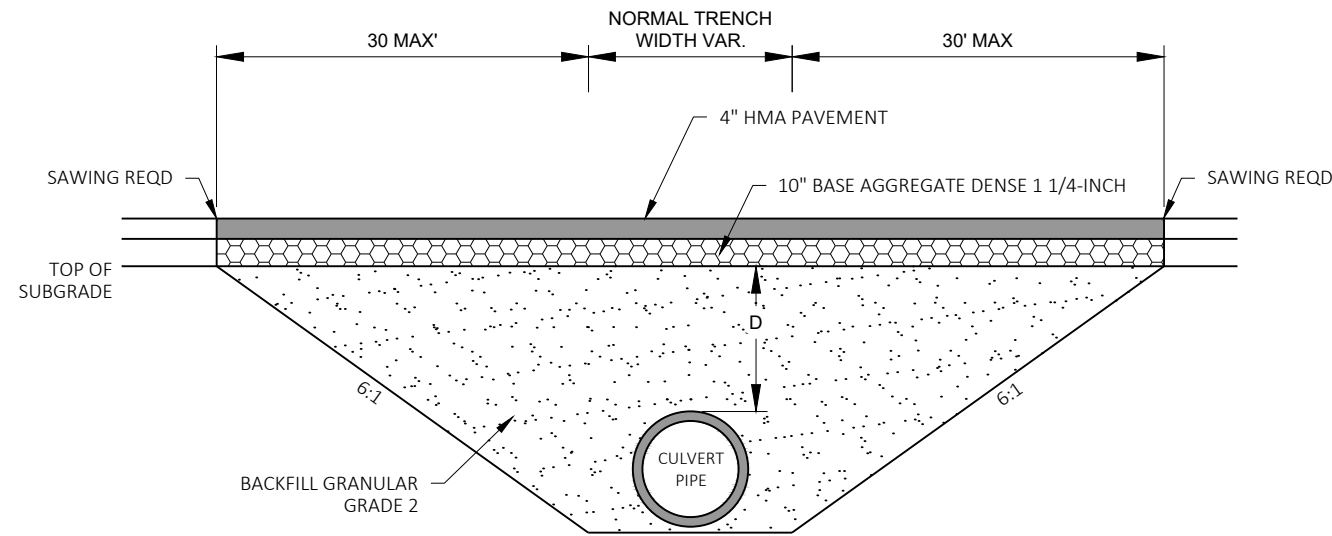

CROSS DRAIN INSTALLATION DETAIL
DEPTH D < 5 FT

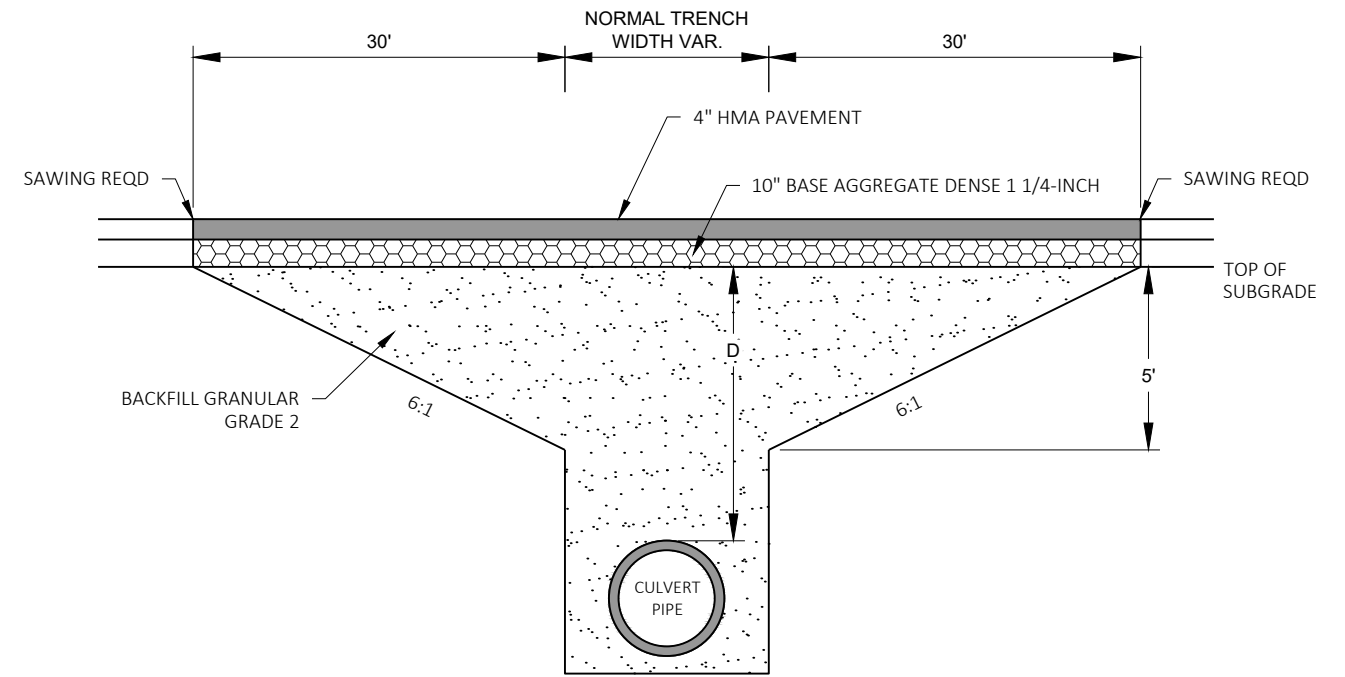

CROSS DRAIN INSTALLATION DETAIL
DEPTH D ≥ 5 FT

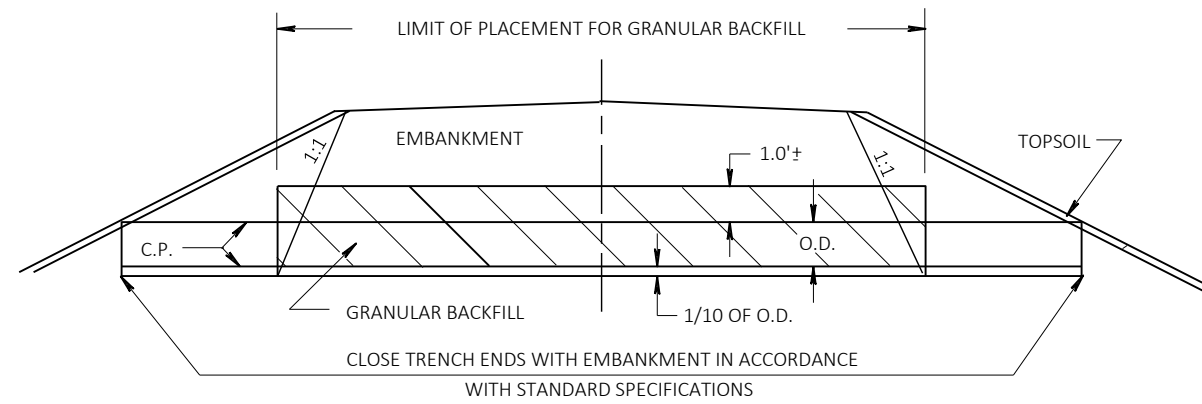

CULVERT BACKFILL DETAIL

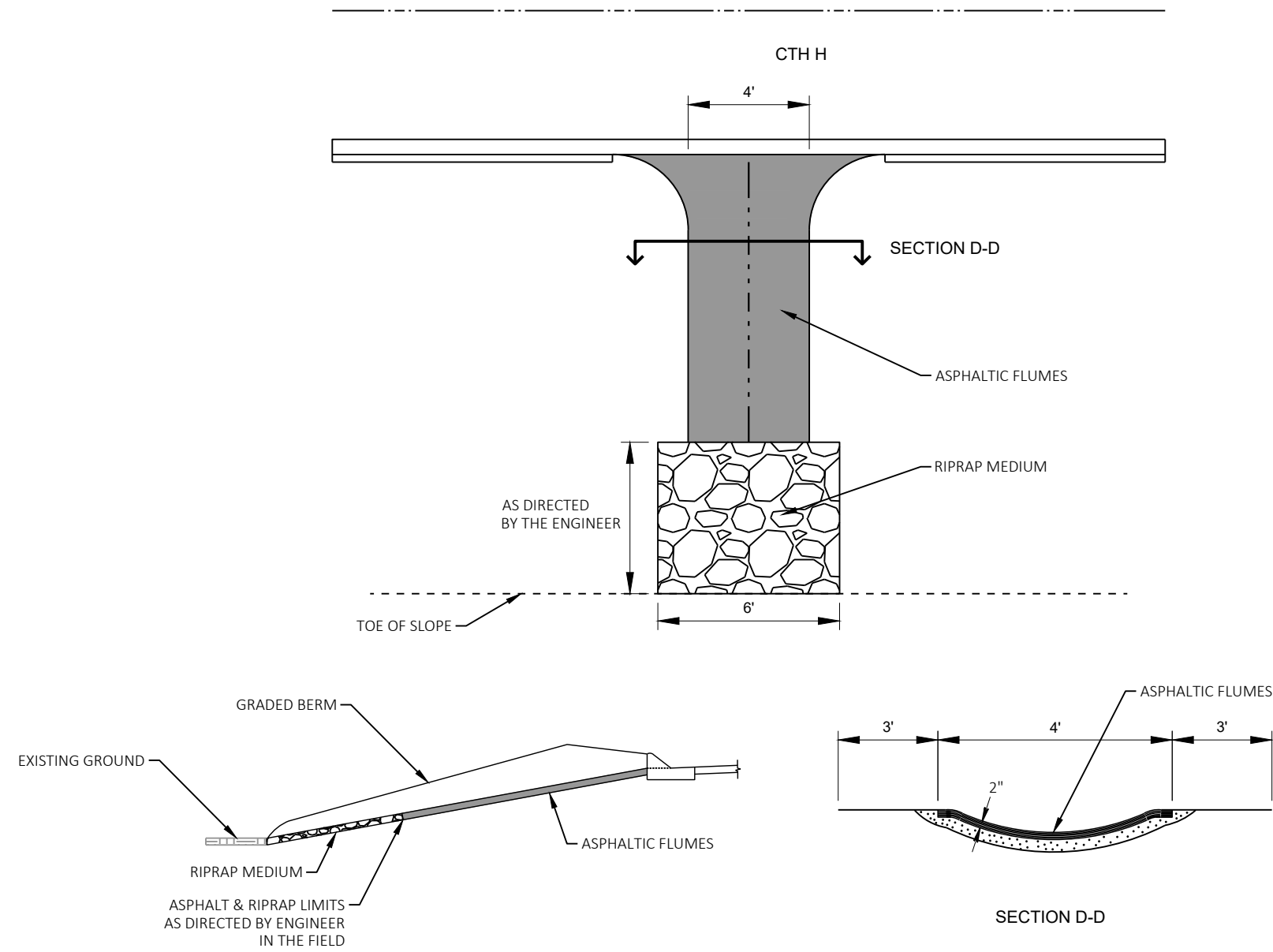

ASPHALTIC FLUME DETAIL
 STA 128+80 LT & RT

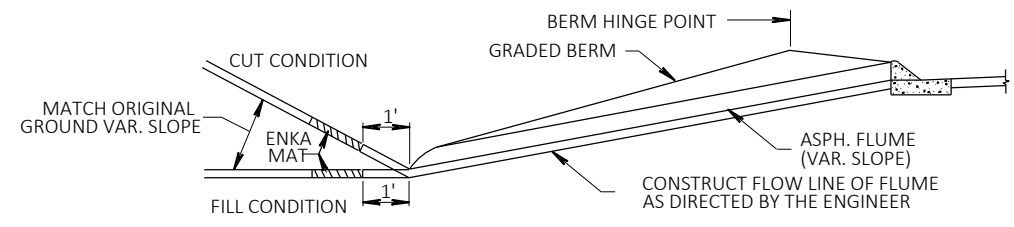
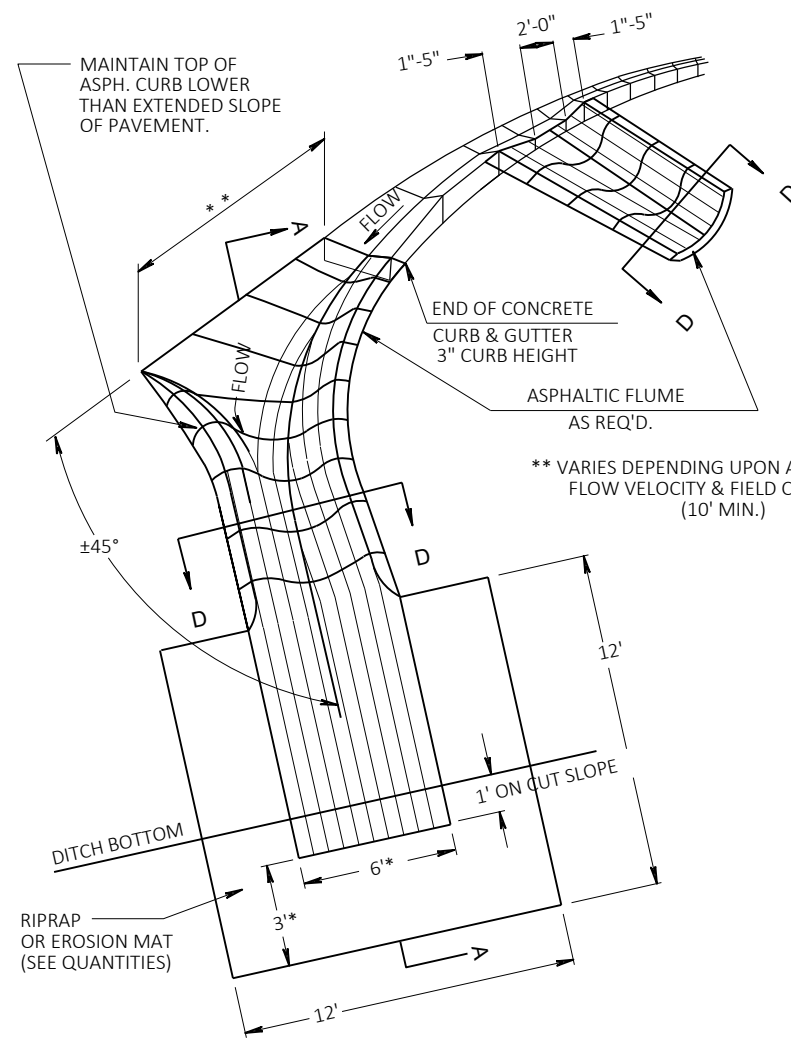

SECTION A-A

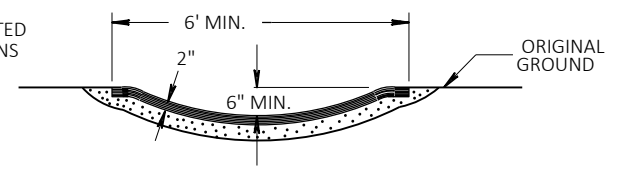

SECTION D-D

ASPHALTIC FLUME DETAIL AT RURAL INTERSECTIONS



BEGIN PROJECT
STA 100+21.72

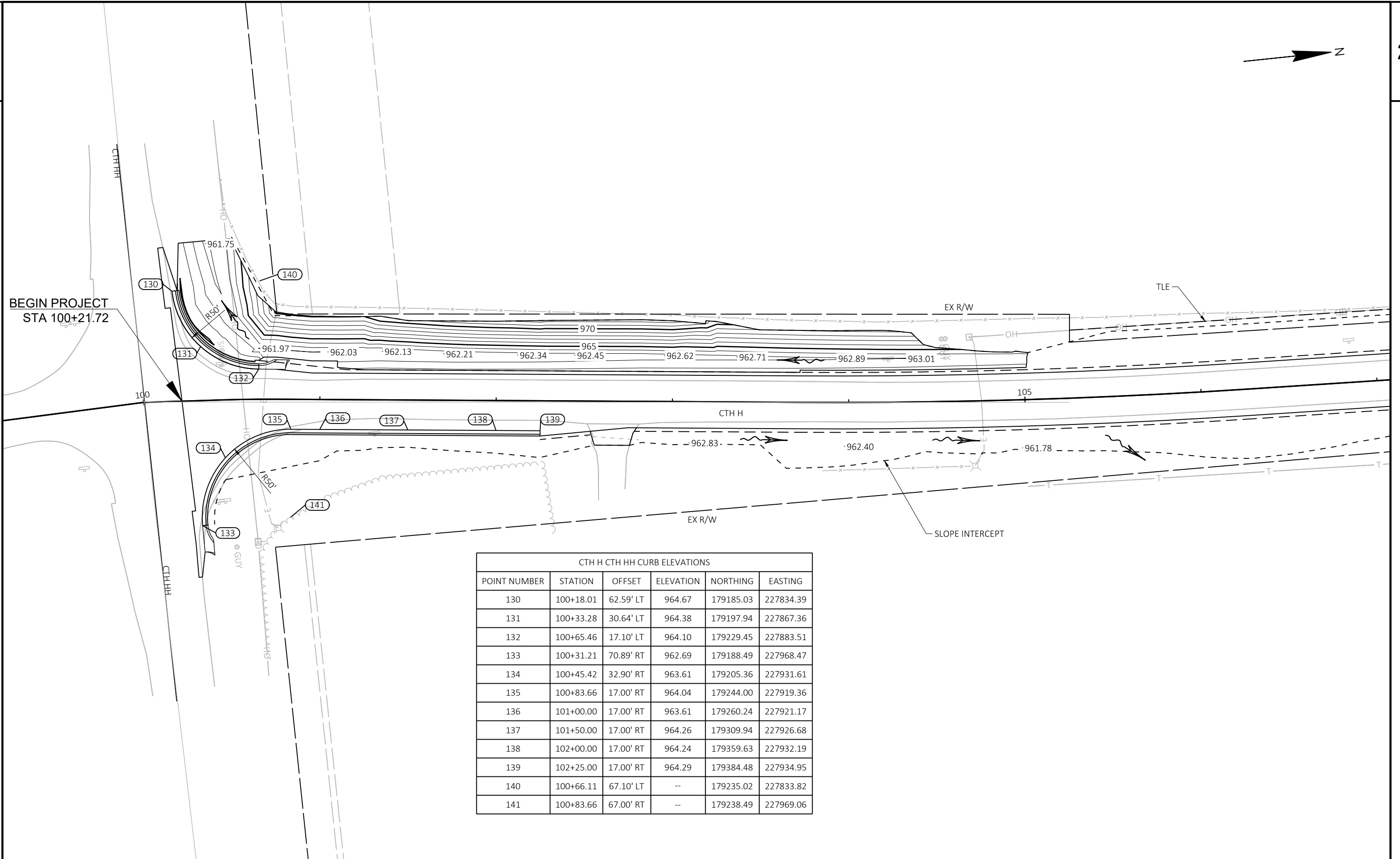

CTH H CTH HH CURB ELEVATIONS					
POINT NUMBER	STATION	OFFSET	ELEVATION	NORTHING	EASTING
130	100+18.01	62.59' LT	964.67	179185.03	227834.39
131	100+33.28	30.64' LT	964.38	179197.94	227867.36
132	100+65.46	17.10' LT	964.10	179229.45	227883.51
133	100+31.21	70.89' RT	962.69	179188.49	227968.47
134	100+45.42	32.90' RT	963.61	179205.36	227931.61
135	100+83.66	17.00' RT	964.04	179244.00	227919.36
136	101+00.00	17.00' RT	963.61	179260.24	227921.17
137	101+50.00	17.00' RT	964.26	179309.94	227926.68
138	102+00.00	17.00' RT	964.24	179359.63	227932.19
139	102+25.00	17.00' RT	964.29	179384.48	227934.95
140	100+66.11	67.10' LT	--	179235.02	227833.82
141	100+83.66	67.00' RT	--	179238.49	227969.06

CURB ELEVATIONS					
POINT NUMBER	STATION	OFFSET	ELEVATION	NORTHING	EASTING
70	116+99.98	17.00' LT	968.42	180859.34	227979.49
71	117+50.00	17.00' LT	970.46	180909.34	227981.12
72	118+00.00	17.00' LT	971.39	180959.31	227982.75
73	118+50.00	17.00' LT	973.01	181009.26	227984.34
74	119+00.00	17.00' LT	973.87	181059.19	227985.81
75	119+50.00	17.00' LT	974.50	181109.13	227987.16
76	120+00.00	17.00' LT	974.65	181159.07	227988.38
77	120+50.00	17.00' LT	975.76	181209.02	227989.47
78	121+00.00	17.00' LT	975.82	181258.97	227990.44
79	121+50.00	17.00' LT	976.63	181308.92	227991.29
80	122+00.00	17.00' LT	976.53	181358.87	227992.01
81	122+50.00	17.00' LT	975.50	181408.88	227992.67
82	122+75.00	17.00' LT	975.04	181433.89	227993.03

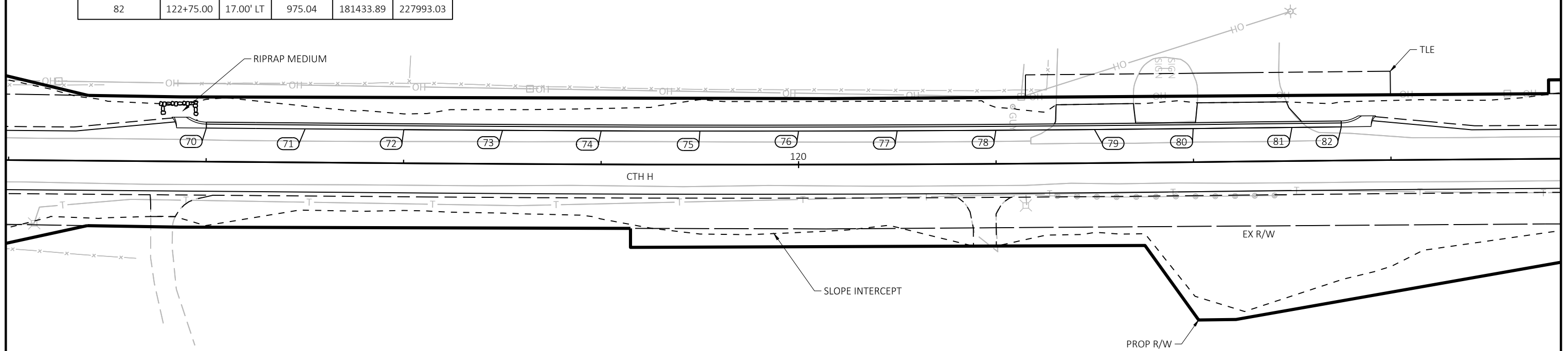

CURB ELEVATIONS CTH H ROCK CUT					
POINT NUMBER	STATION	OFFSET	ELEVATION	NORTHING	EASTING
83	127+50.00	17.18' LT	970.77	181908.84	228002.59
84	127+50.00	17.22' RT	971.22	181908.23	228036.99
85	128+00.03	17.08' LT	973.05	181958.80	228003.50
86	128+00.00	17.08' RT	973.05	181958.29	228037.65
87	128+50.00	17.01' LT	974.67	182008.71	228004.20
88	128+50.00	17.00' RT	974.67	182008.34	228038.20
89	129+00.00	16.98' LT	977.26	182058.65	228004.69
90	129+00.00	16.96' RT	976.77	182058.40	228038.62
91	129+50.00	16.98' LT	979.03	182108.59	228004.96
92	129+50.00	16.98' RT	979.03	182108.46	228038.92
93	130+00.00	17.00' LT	980.38	182158.57	228005.09
94	130+00.00	17.00' RT	979.88	182158.48	228039.09
95	130+50.00	17.00' LT	981.31	182208.57	228005.21
96	130+50.00	17.00' RT	980.81	182208.48	228039.21
97	131+00.00	17.00' LT	981.32	182258.57	228005.34

CURB ELEVATIONS CTH H ROCK CUT					
POINT NUMBER	STATION	OFFSET	ELEVATION	NORTHING	EASTING
98	131+00.00	17.00' RT	981.32	182258.48	228039.34
99	131+37.00	17.00' LT	981.44	182295.57	228005.43
100	131+37.00	17.00' RT	981.93	182295.48	228039.43
101	131+50.00	17.00' LT	981.92	182308.57	228005.46
102	131+50.05	17.00' RT	981.92	182308.54	228039.46
103	132+00.00	17.00' LT	981.10	182358.57	228005.58
104	132+00.00	17.00' RT	981.60	182358.48	228039.58
105	132+50.00	17.00' LT	980.36	182408.57	228005.71
106	132+50.00	17.00' RT	980.86	182408.48	228039.71
107	133+00.00	17.00' LT	979.71	182458.57	228005.83
108	133+00.00	17.00' RT	979.71	182458.48	228039.83
109	133+50.00	17.00' LT	977.64	182508.57	228005.95
110	133+50.00	17.00' RT	977.64	182508.48	228039.95

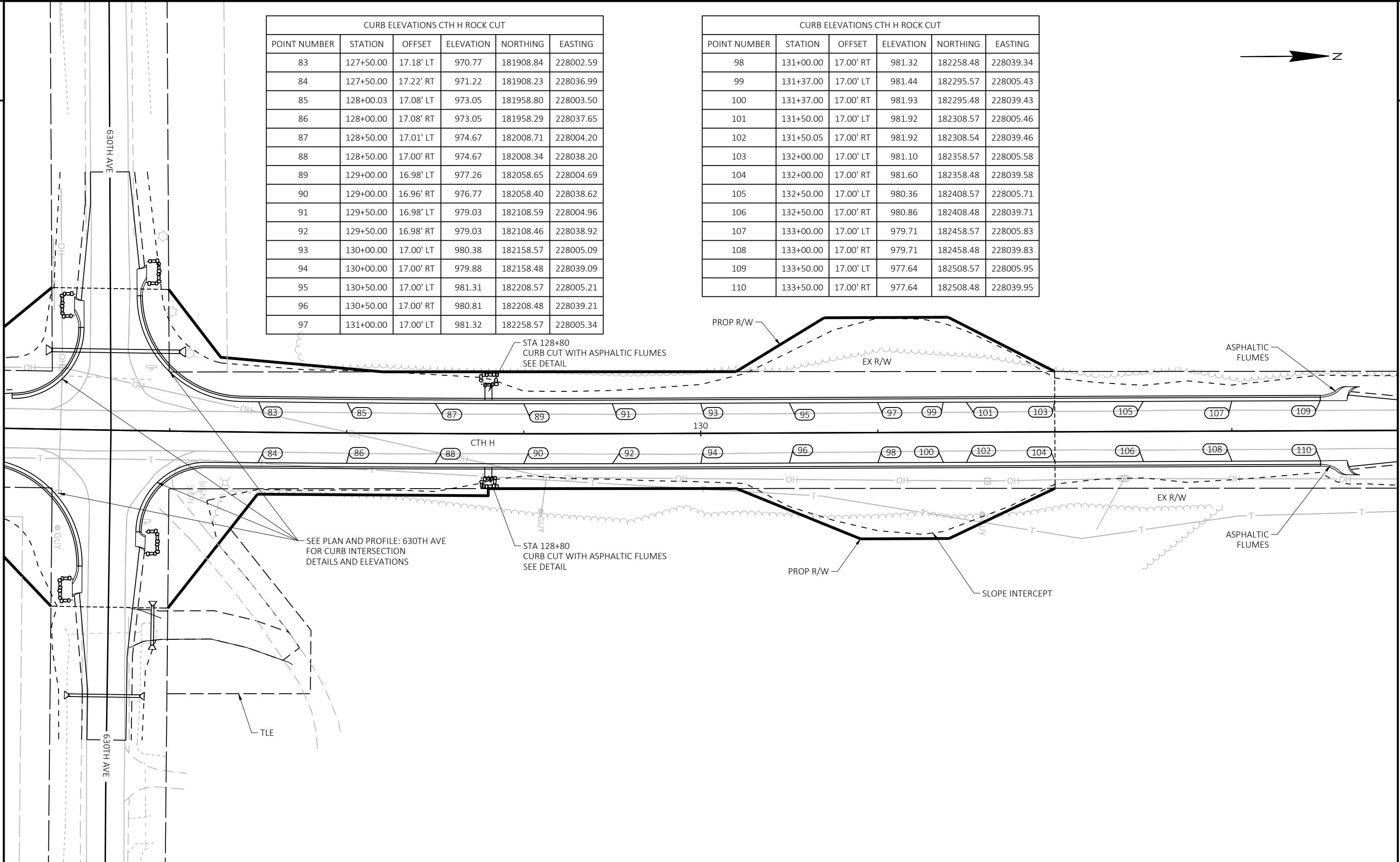
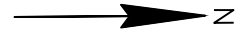

CTH M CURB ELEVATIONS					
POINT NUMBER	STATION	OFFSET	ELEVATION	NORTHING	EASTING
115	196+50.00	17.00' RT	1026.97	188797.78	227842.91
116	197+00.00	17.00' RT	1027.34	188846.03	227829.64
117	197+50.00	17.00' RT	1028.62	188894.25	227816.24
118	198+00.00	17.00' RT	1029.29	188942.43	227802.70
119	198+50.00	17.00' RT	1029.37	188990.58	227789.03
120	199+00.00	17.00' RT	1029.84	189038.68	227775.23
121	199+50.00	17.00' RT	1030.21	189086.73	227761.36
122	200+00.00	17.00' RT	1030.97	189134.76	227747.49
123	200+50.00	17.00' RT	1031.14	189182.80	227733.61
124	201+00.00	17.00' RT	1031.20	189230.85	227719.73
125	201+50.00	17.00' RT	1031.16	189278.95	227705.58
126	202+00.00	17.00' RT	1031.02	189326.93	227691.04
127	202+50.00	17.00' RT	1030.30	189374.80	227676.11

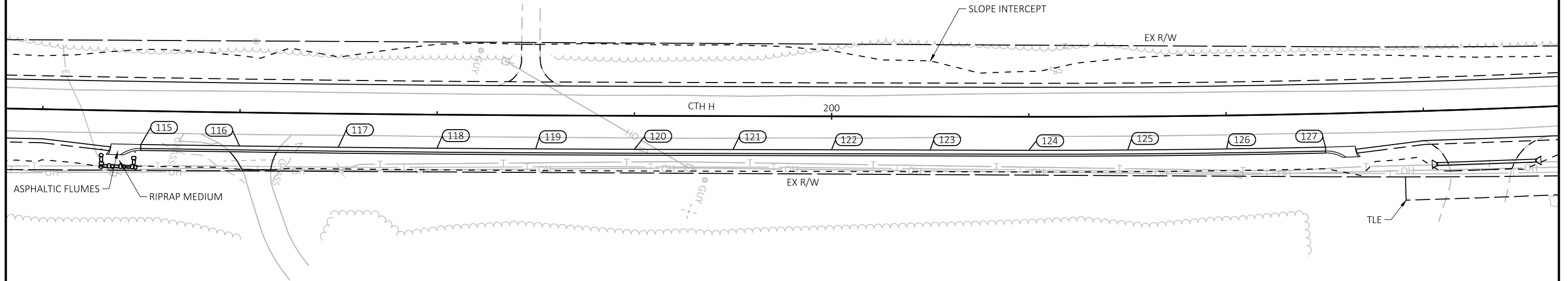

CTH H CTH M CURB ELEVATIONS					
POINT NUMBER	STATION	OFFSET	ELEVATION	NORTHING	EASTING
142	233+77.06	16.74' LT	978.70	192320.15	227891.77
143	234+08.70	29.45' LT	977.82	192351.32	227877.96
144	234+22.34	60.70' LT	976.94	192363.86	227846.26
145	233+79.60	17.00' RT	978.99	192323.86	227925.40
146	234+08.20	29.05' RT	977.67	192352.86	227936.45
147	234+19.59	57.93' RT	975.84	192365.25	227964.91
148	233+77.35	61.74' LT	--	192318.87	227846.79
149	233+79.60	57.00' RT	--	192325.25	227965.38

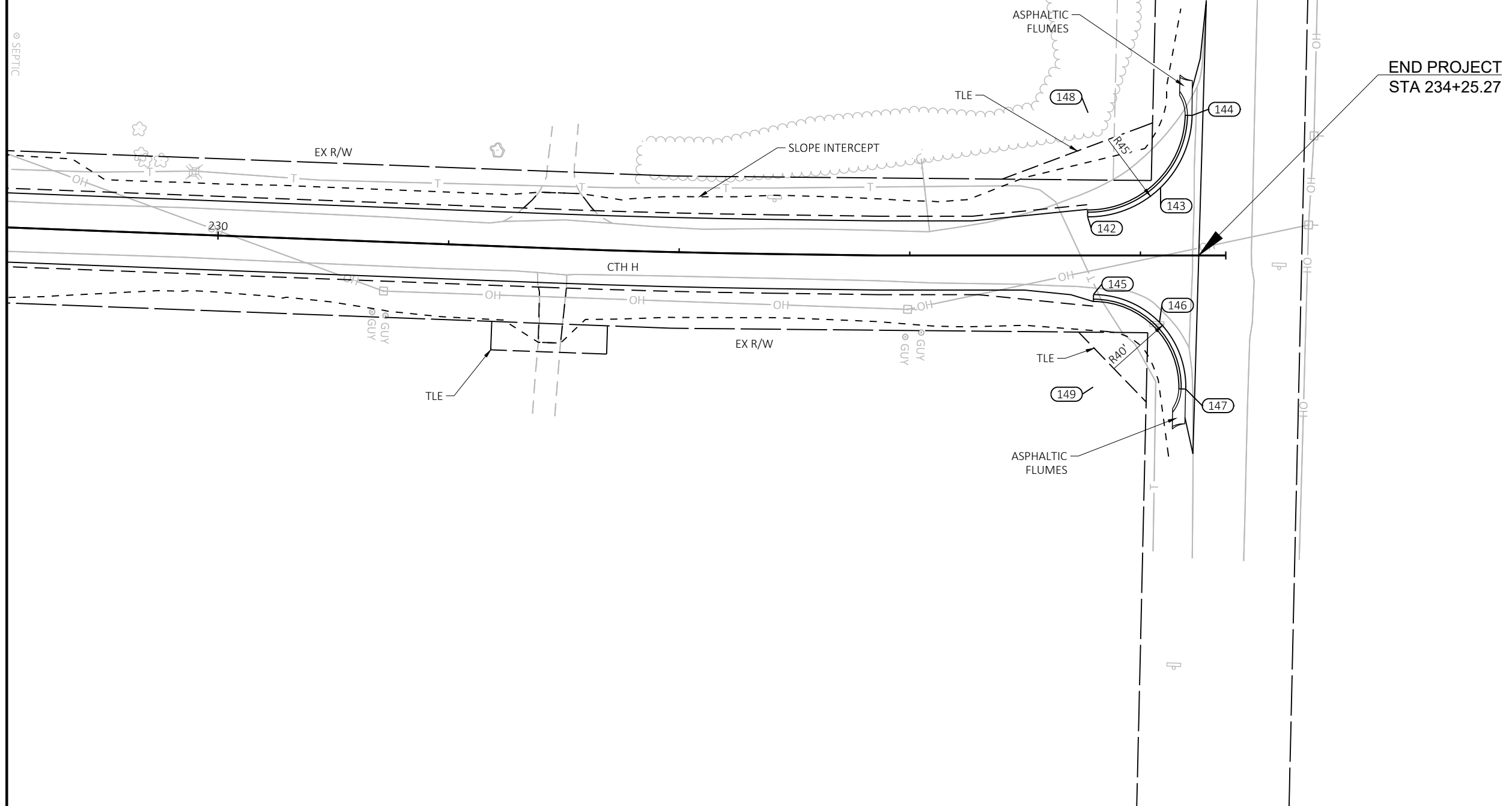

BEGIN PROJECT
STA 100+21.72

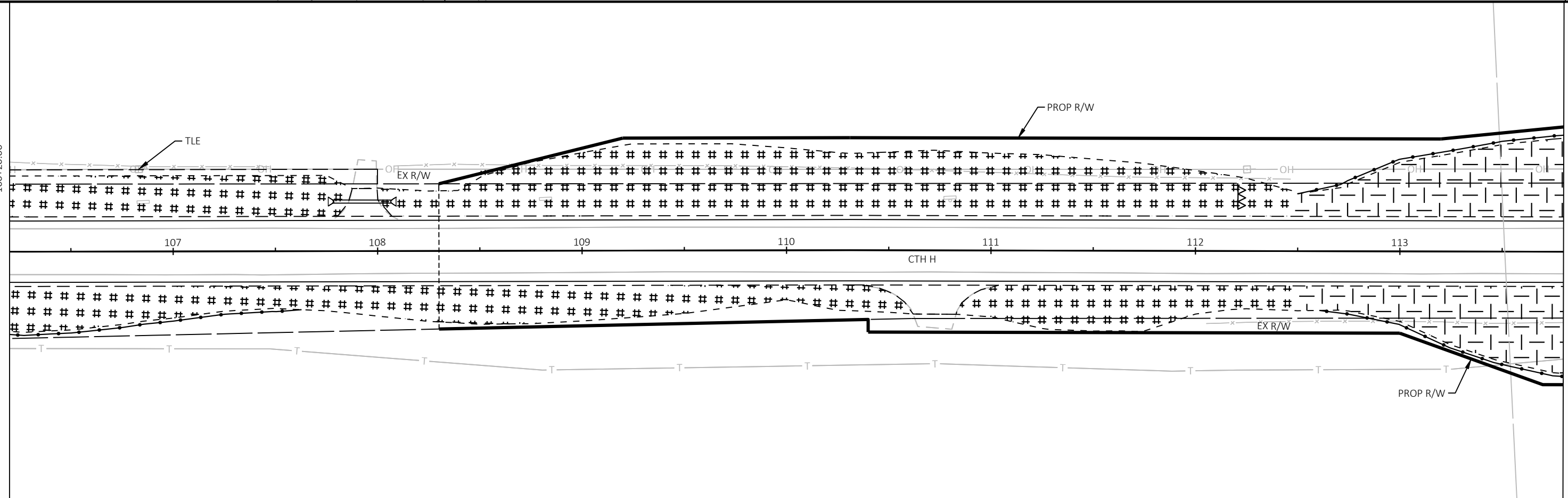
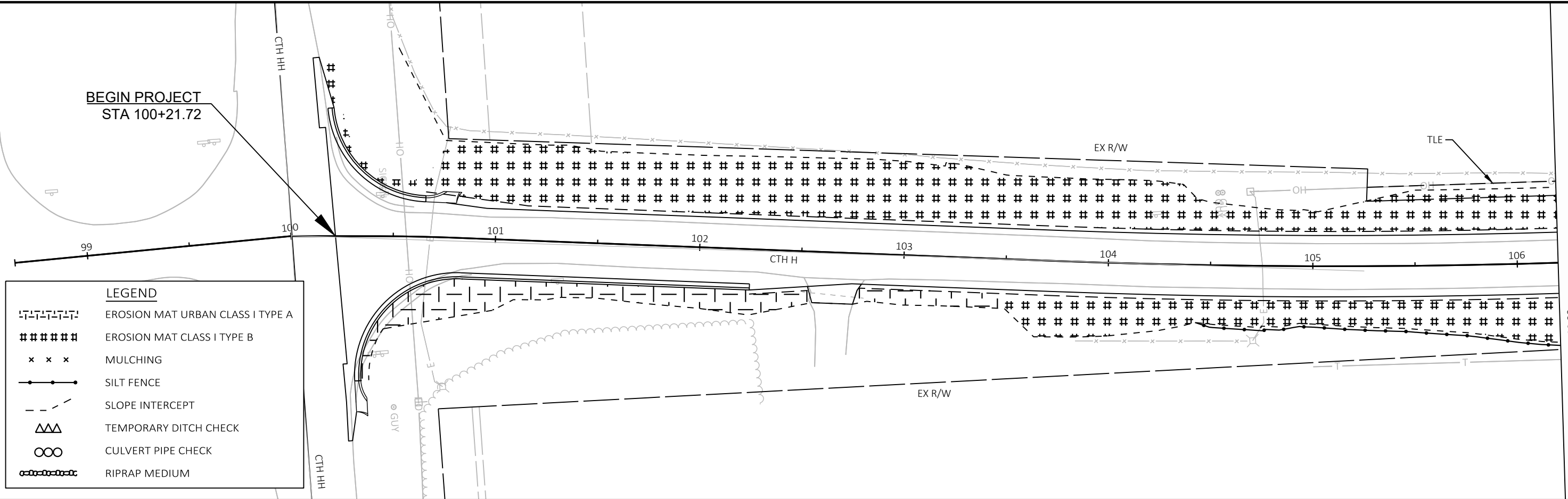

PROJECT NO: 7880-07-73

HWY: CTH H

COUNTY: DUNN

EROSION CONTROL

SHEET

E

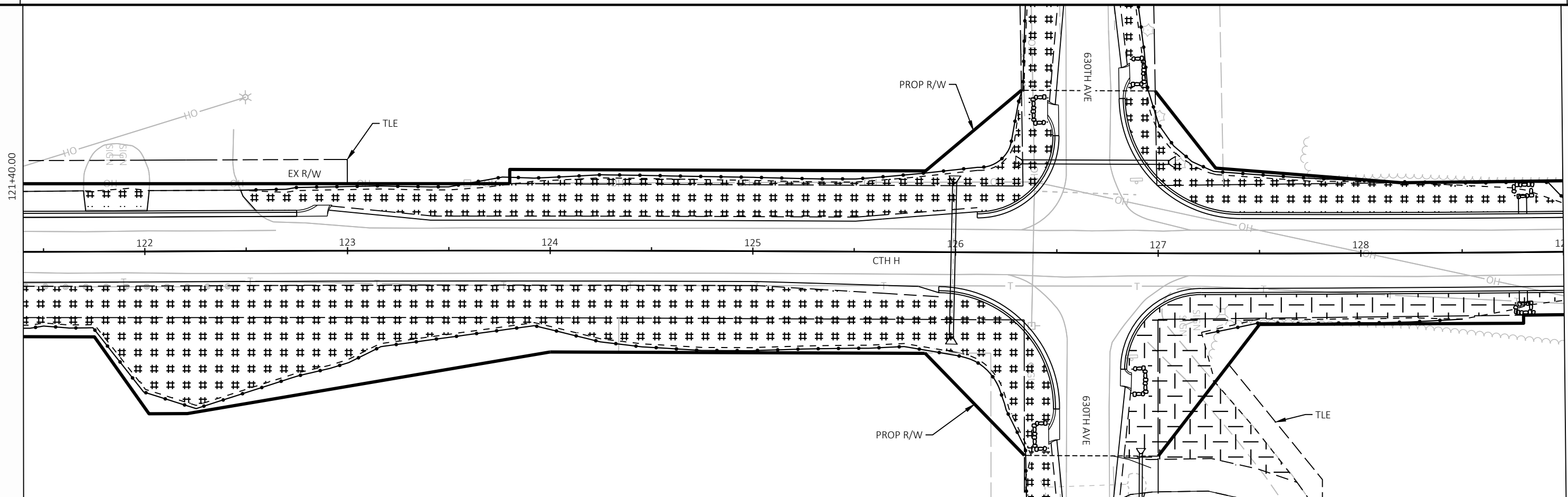
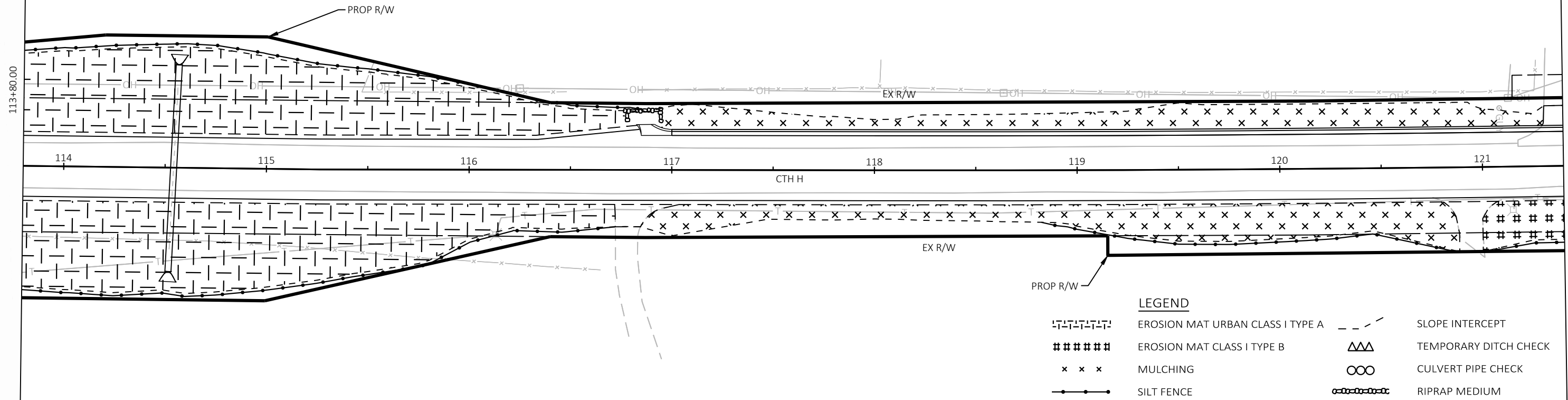

PROJECT NO: 7880-07-73

HWY: CTH H

COUNTY: DUNN

EROSION CONTROL

SHEET

E

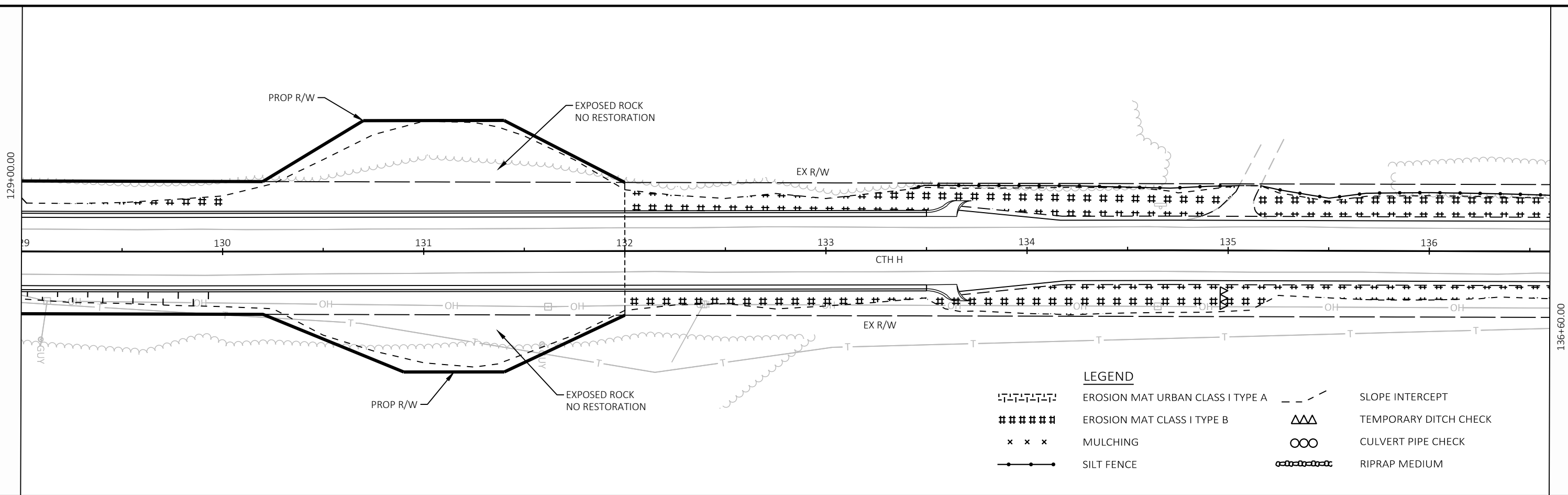

LEGEND

-T-T-T-T-T-	EROSION MAT URBAN CLASS I TYPE A	- - - -	SLOPE INTERCEPT
#####	EROSION MAT CLASS I TYPE B	△△△	TEMPORARY DITCH CHECK
x x x	MULCHING	○○○	CULVERT PIPE CHECK
—●—●—●—	SILT FENCE	—○—○—○—	RIPRAP MEDIUM

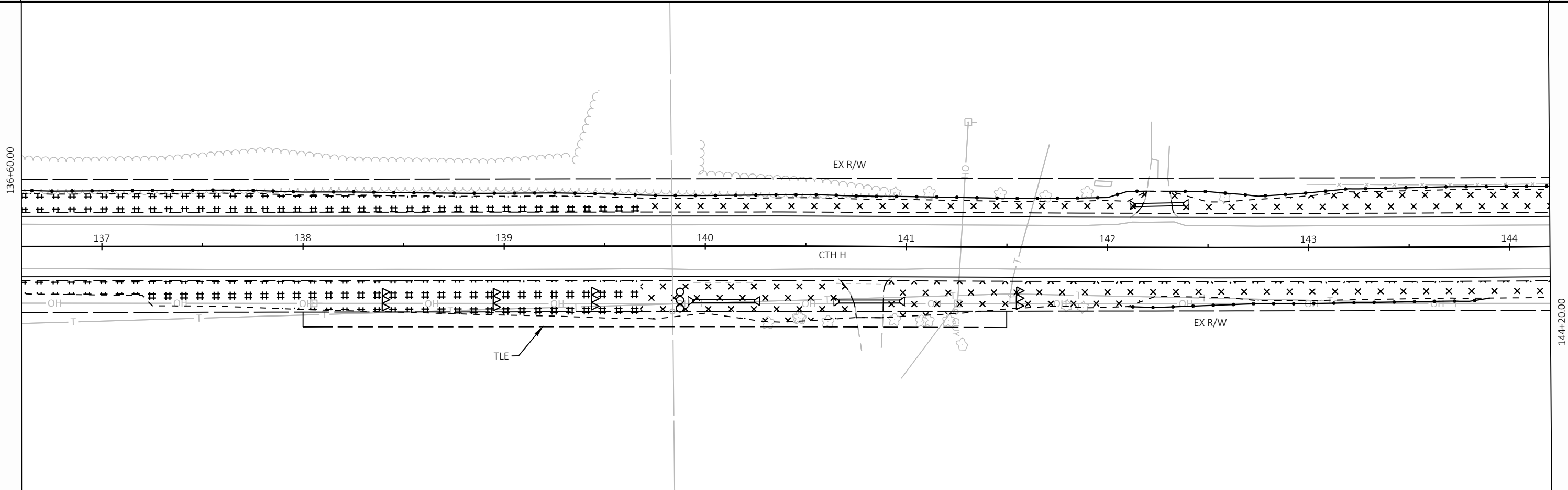

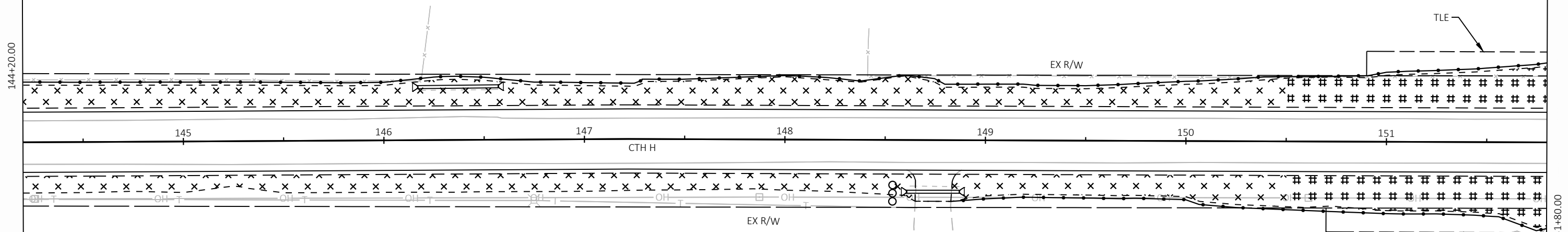

LEGEND

- | | |
|--|---|
| <ul style="list-style-type: none"> EROSION MAT URBAN CLASS I TYPE A EROSION MAT CLASS I TYPE B MULCHING SILT FENCE | <ul style="list-style-type: none"> SLOPE INTERCEPT TEMPORARY DITCH CHECK CULVERT PIPE CHECK RIPRAP MEDIUM |
|--|---|

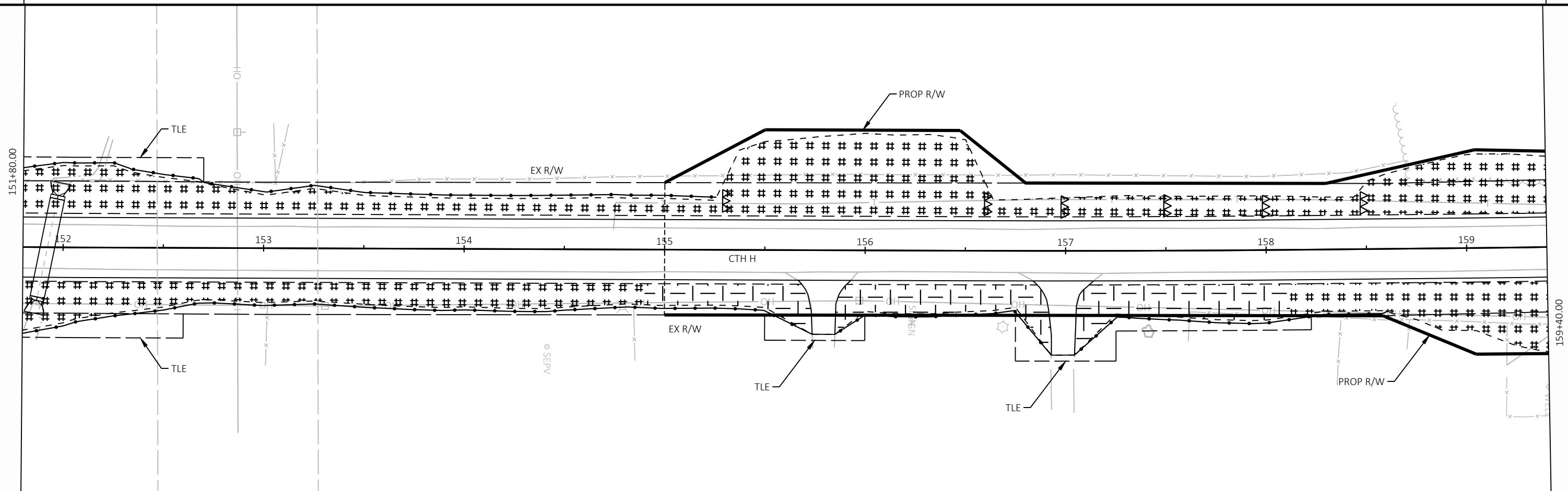

PROJECT NO: 7880-07-73	HWY: CTH H	COUNTY: DUNN	EROSION CONTROL	SHEET	E
------------------------	------------	--------------	-----------------	-------	----------

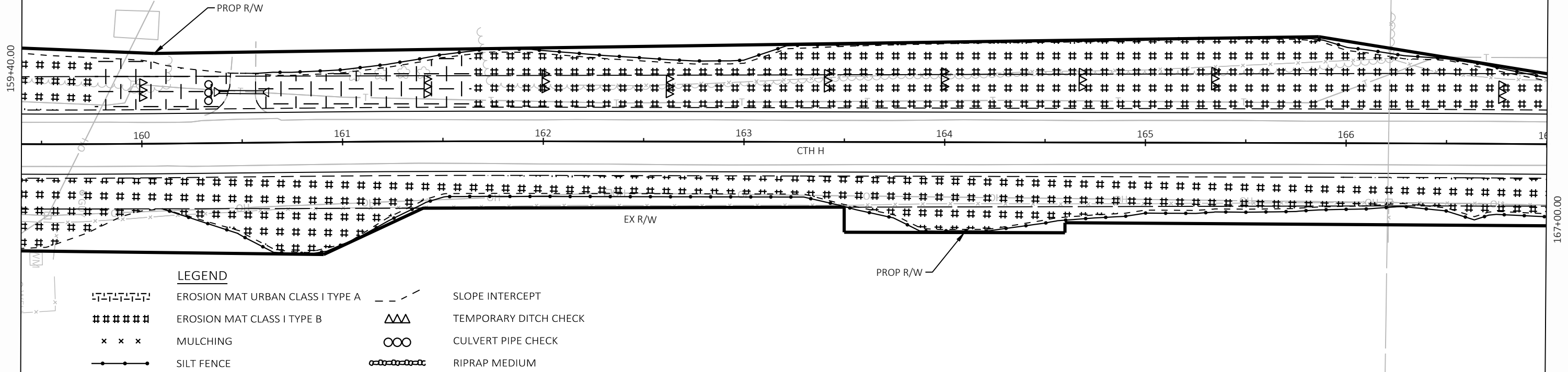

LEGEND

- |-|-|-|-|-|-|-| EROSION MAT URBAN CLASS I TYPE A
- ##### EROSION MAT CLASS I TYPE B
- x x x MULCHING
- SILT FENCE
- - - - SLOPE INTERCEPT
- △△△ TEMPORARY DITCH CHECK
- CULVERT PIPE CHECK
- RIPRAP MEDIUM

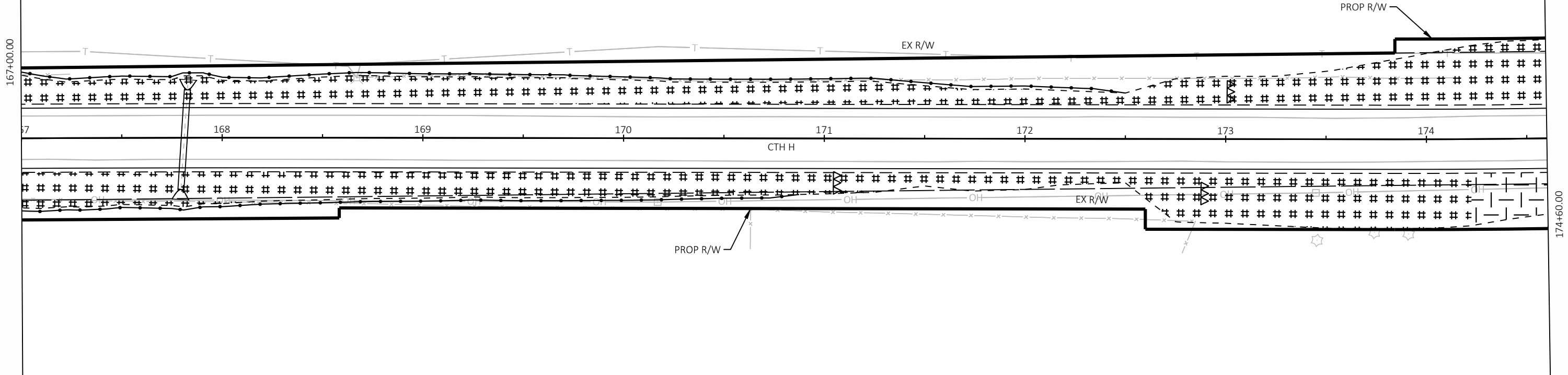

PROJECT NO: 7880-07-73

HWY: CTH H

COUNTY: DUNN

EROSION CONTROL

SHEET

E

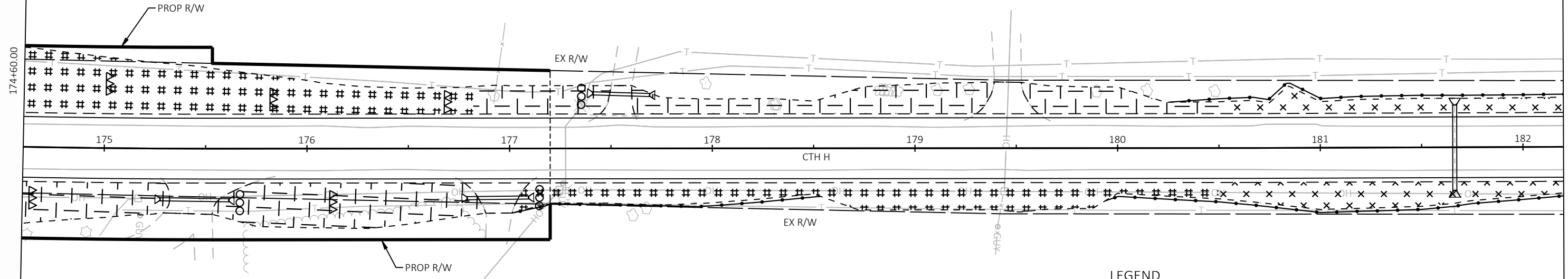

LEGEND

!-!-!-!-!-!-!-!	EROSION MAT URBAN CLASS I TYPE A	- - - - -	SLOPE INTERCEPT
#####	EROSION MAT CLASS I TYPE B	△△△	TEMPORARY DITCH CHECK
x x x	MULCHING	○○○	CULVERT PIPE CHECK
.....	SILT FENCE	⊖-⊖-⊖-⊖-⊖-⊖-⊖	RIPRAP MEDIUM

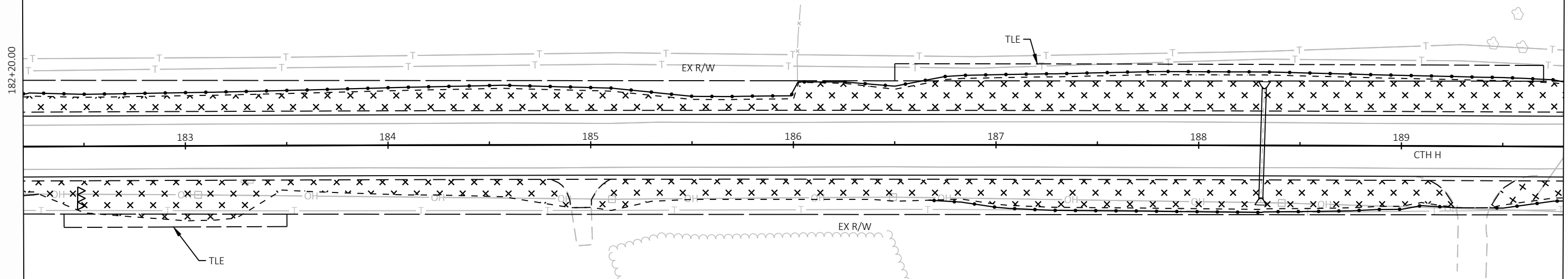

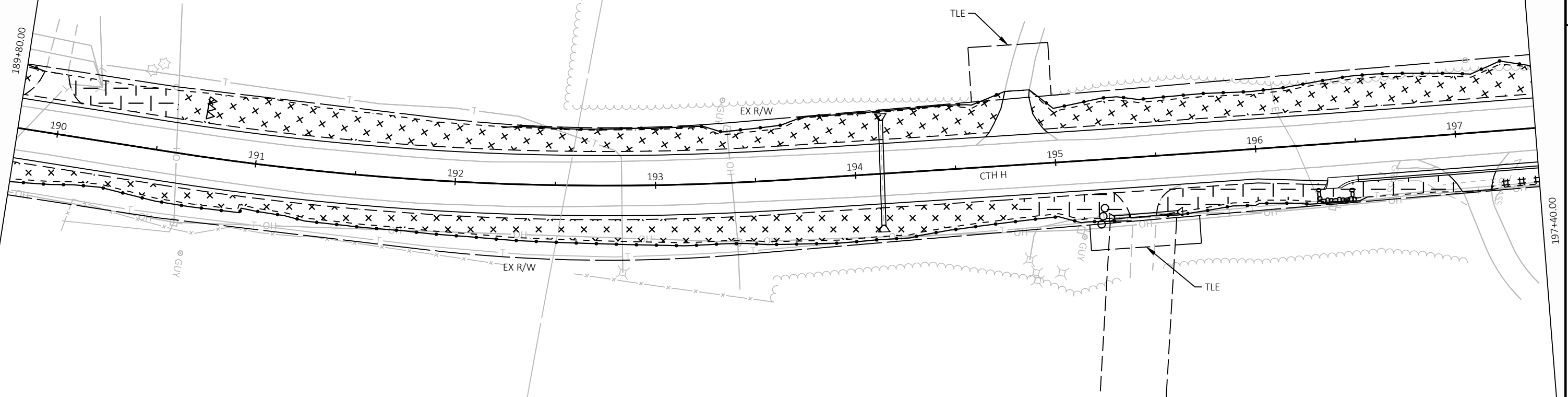

LEGEND

- | | | | |
|--|----------------------------------|--|-----------------------|
| | EROSION MAT URBAN CLASS I TYPE A | | SLOPE INTERCEPT |
| | EROSION MAT CLASS I TYPE B | | TEMPORARY DITCH CHECK |
| | MULCHING | | CULVERT PIPE CHECK |
| | SILT FENCE | | RIPRAP MEDIUM |

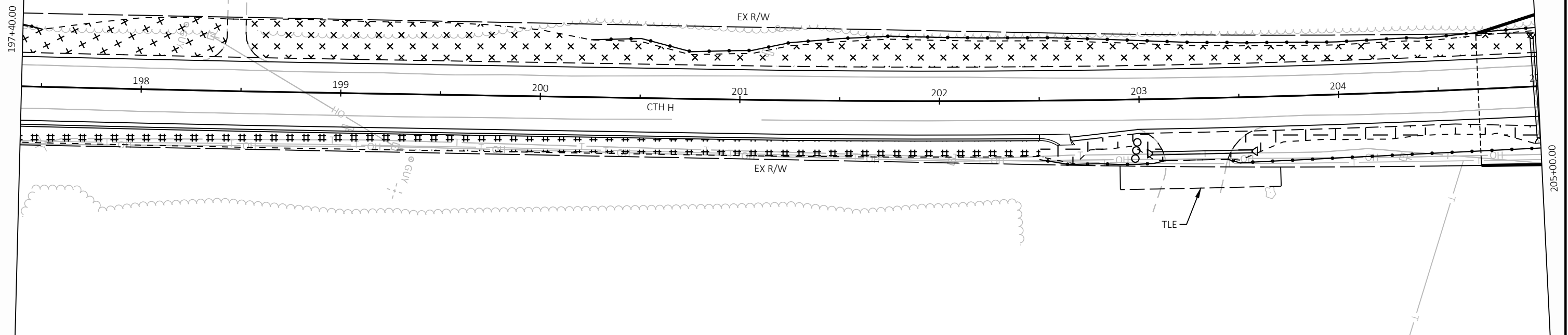

PROJECT NO: 7880-07-73

HWY: CTH H

COUNTY: DUNN

EROSION CONTROL

SHEET

E

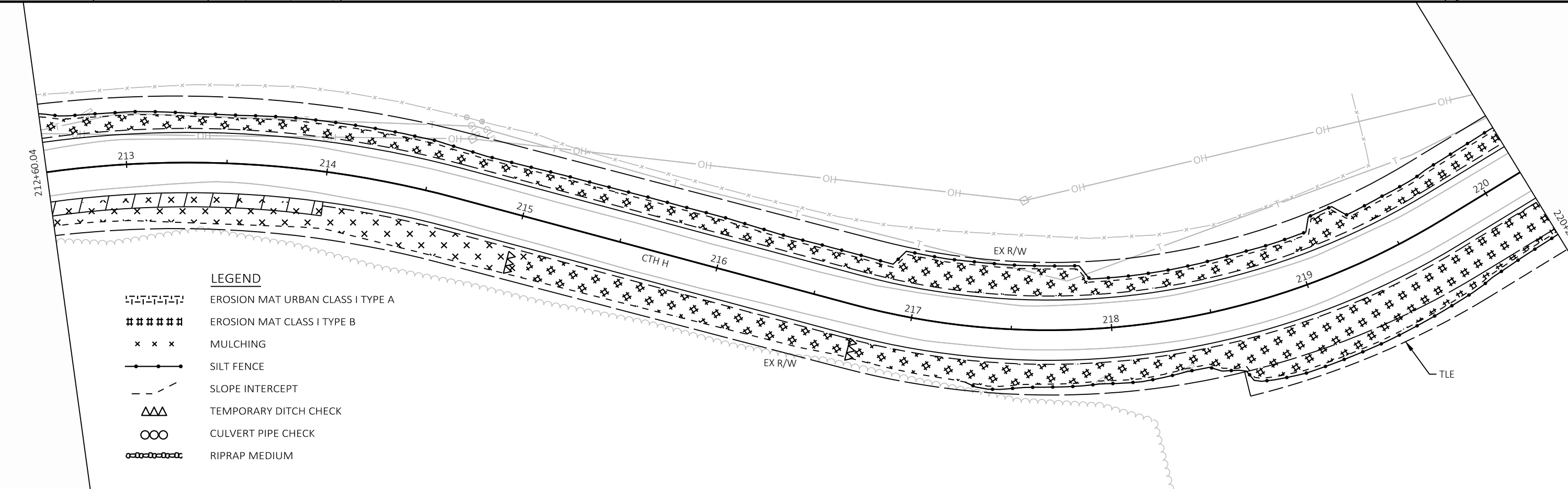
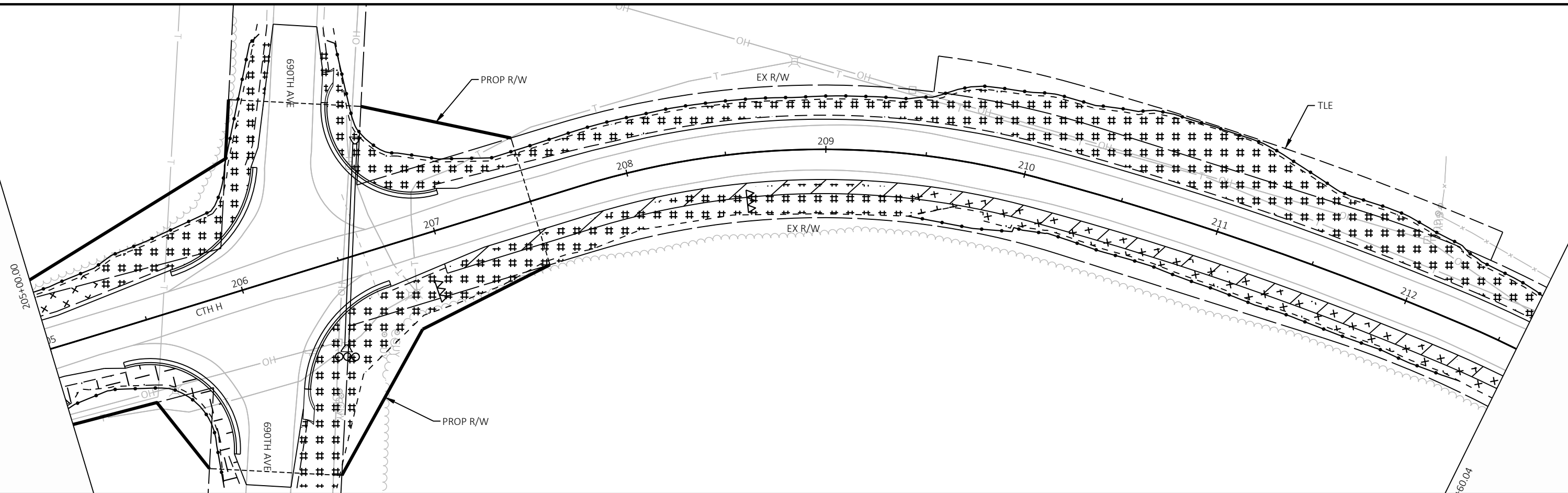

LEGEND

- ⎓⎓⎓⎓⎓⎓ EROSION MAT URBAN CLASS I TYPE A
- ##### EROSION MAT CLASS I TYPE B
- x x x MULCHING
- SILT FENCE
- - - SLOPE INTERCEPT
- △△△ TEMPORARY DITCH CHECK
- CULVERT PIPE CHECK
- ⊖⊖⊖⊖⊖ RIPRAP MEDIUM

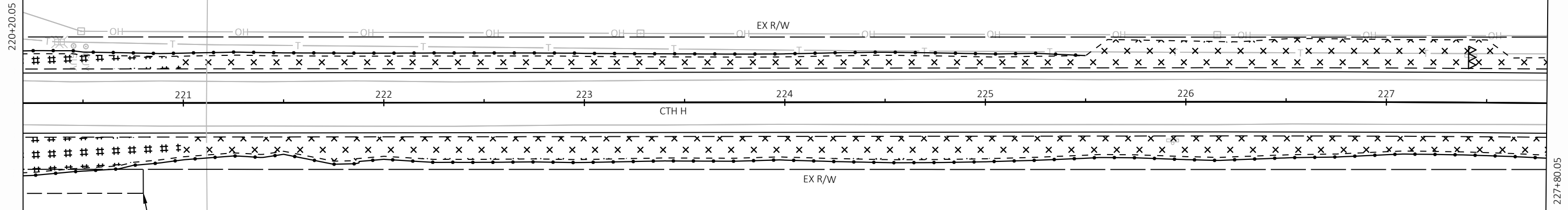

LEGEND

- |-|-|-|-|-|-|-| EROSION MAT URBAN CLASS I TYPE A
- ##### EROSION MAT CLASS I TYPE B
- x x x MULCHING
- SILTY FENCE
- - - - SLOPE INTERCEPT
- △△△ TEMPORARY DITCH CHECK
- CULVERT PIPE CHECK
- RIPRAP MEDIUM

TLE

227+80.05

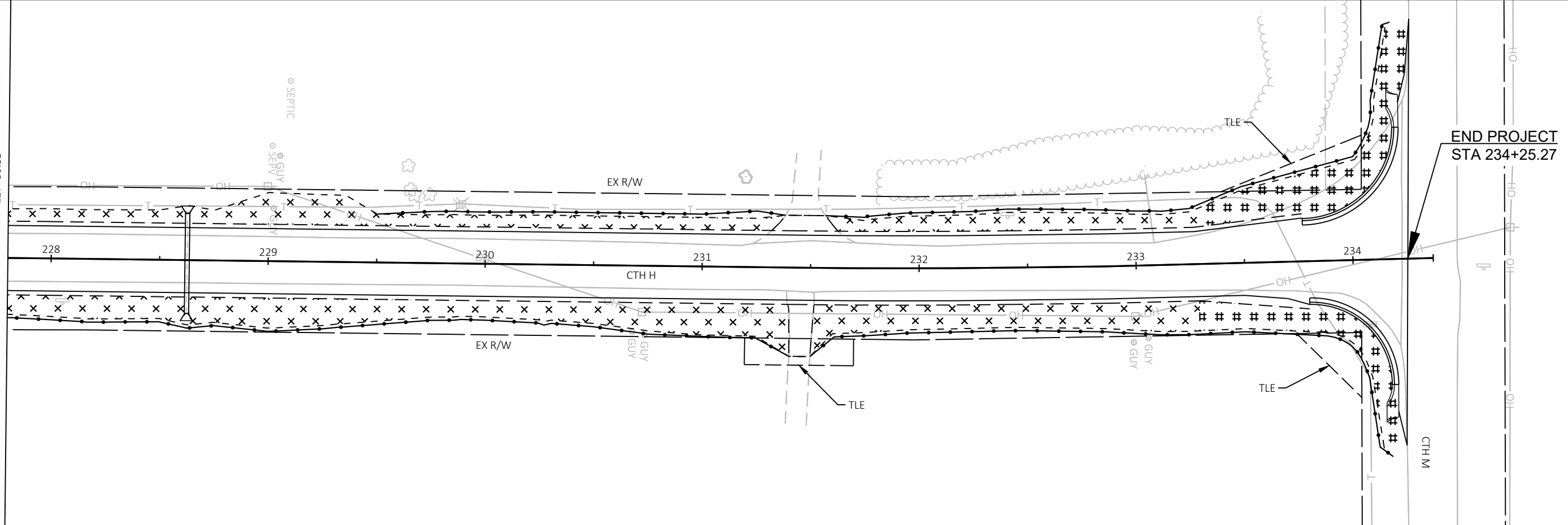

END PROJECT
STA 234+25.27

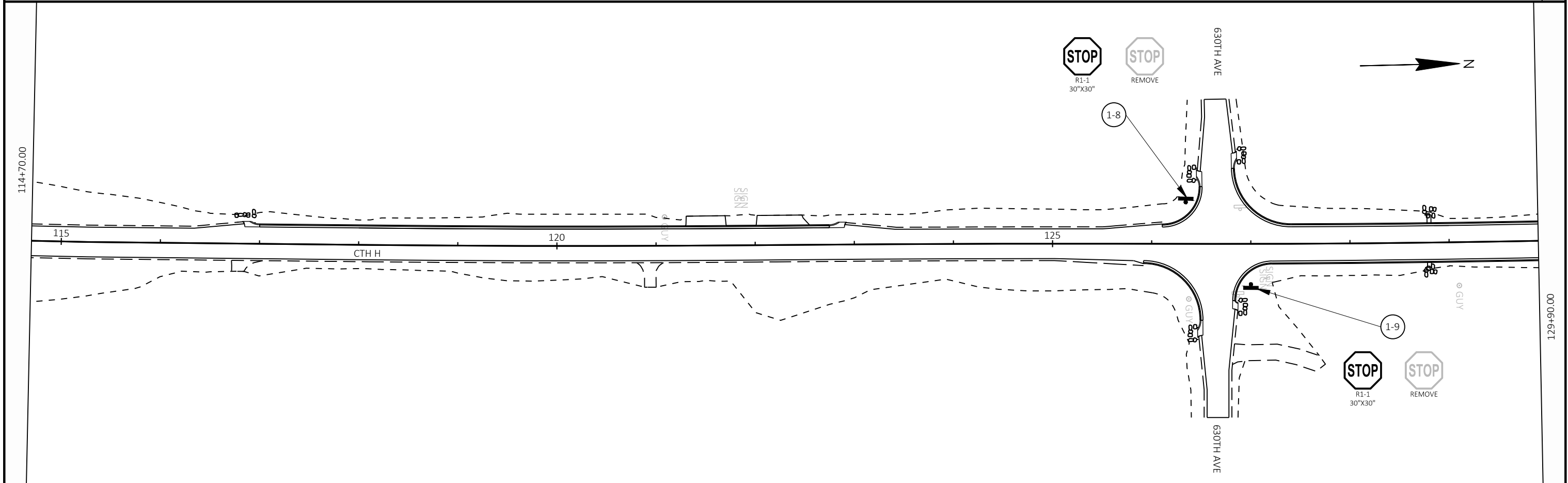
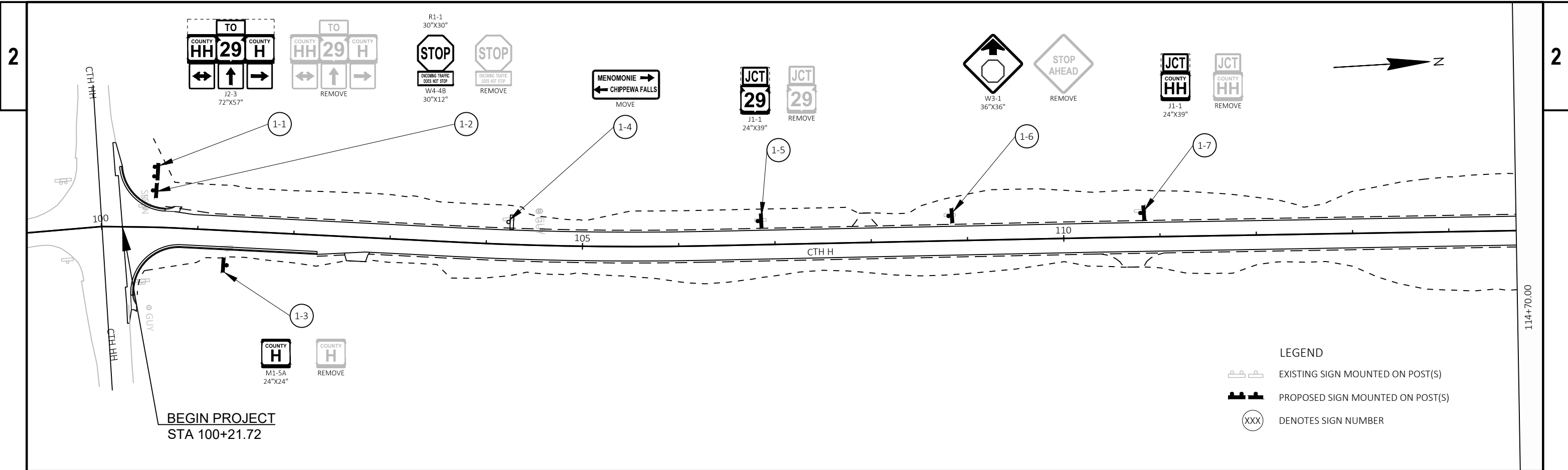

PROJECT NO: 7880-07-73	HWY: CTH H	COUNTY: DUNN	PERMANENT SIGNING	SHEET	E
------------------------	------------	--------------	-------------------	-------	---



2-1

129+90.00

130 135 140 145

CTH H

GUY

GUY

LEGEND

 EXISTING SIGN MOUNTED ON POST(S)

 PROPOSED SIGN MOUNTED ON POST(S)

 DENOTES SIGN NUMBER

145+10.00

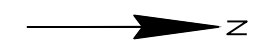

145+10.00

150 155 160

CTH H

GUY

GUY

160+30.00

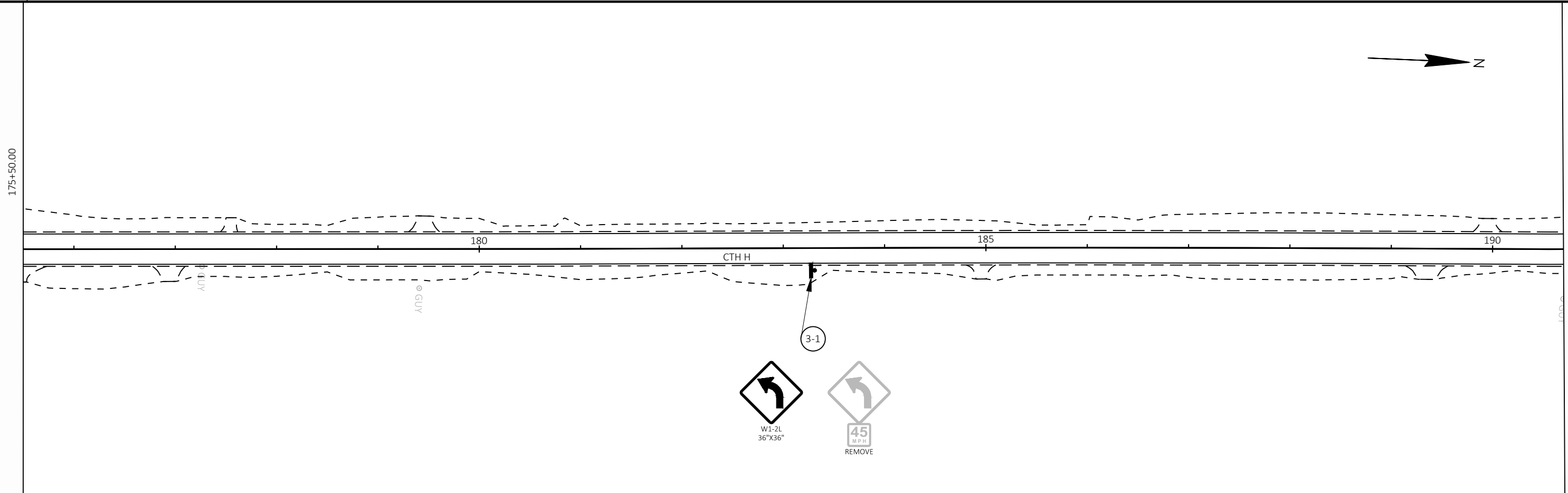
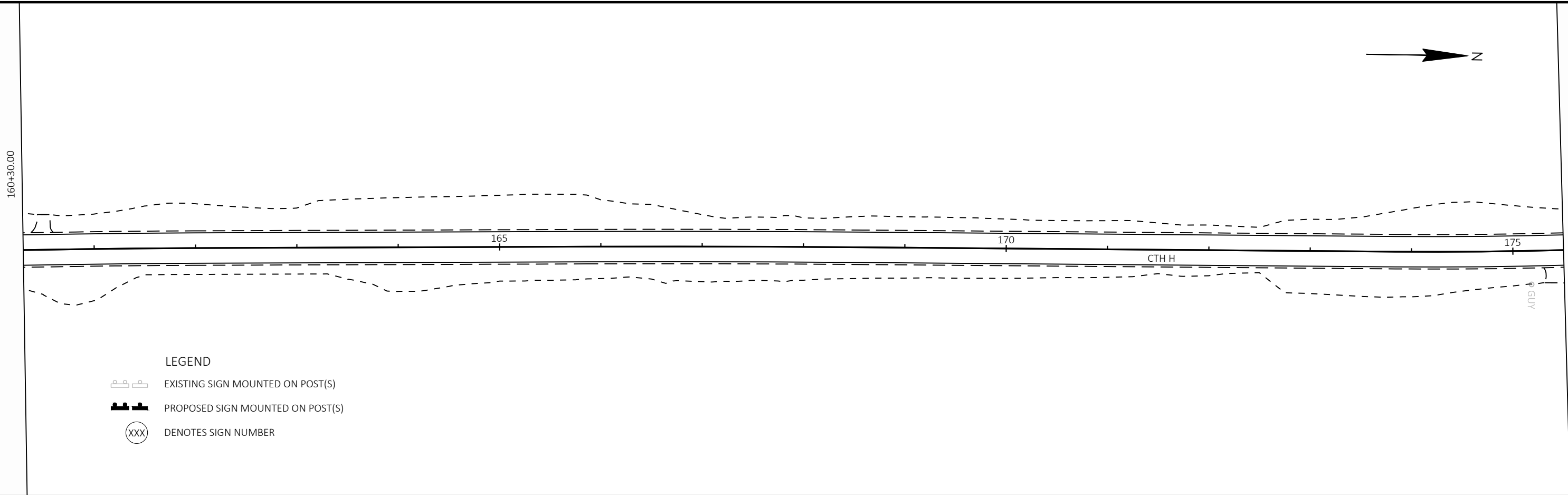

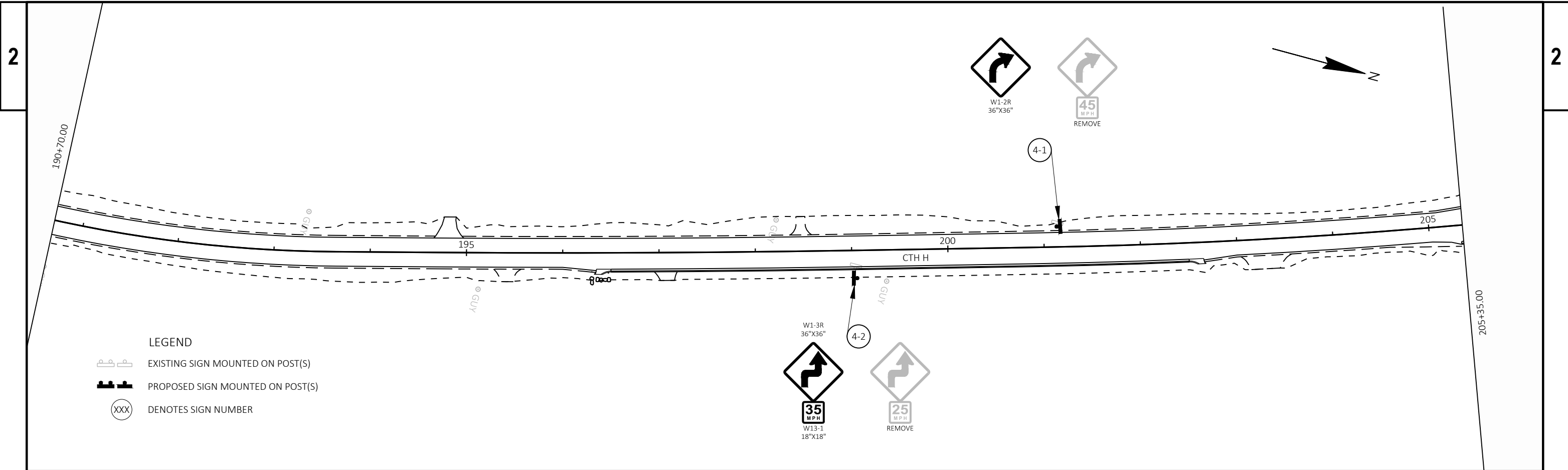

PROJECT NO: 7880-07-73	HWY: CTH H	COUNTY: DUNN	PERMANENT SIGNING	SHEET	E
------------------------	------------	--------------	-------------------	-------	---

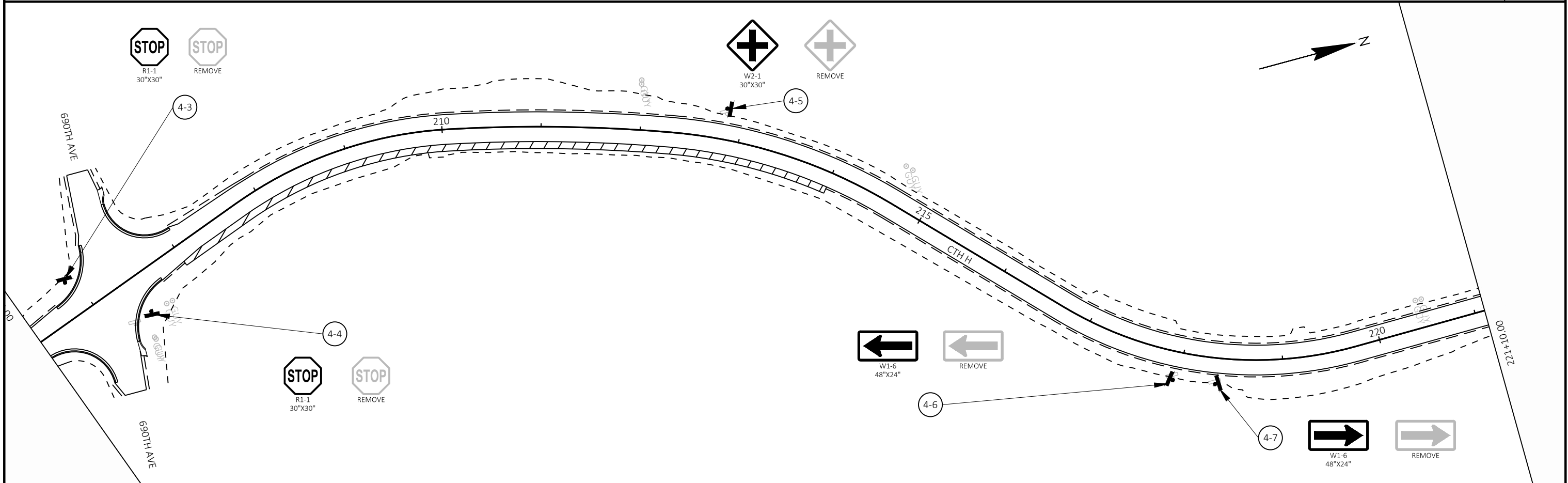

- LEGEND**
- EXISTING SIGN MOUNTED ON POST(S)
 - PROPOSED SIGN MOUNTED ON POST(S)
 - DENOTES SIGN NUMBER





PROJECT NO: 7880-07-73	HWY: CTH H	COUNTY: DUNN	PERMANENT SIGNING	SHEET	E
------------------------	------------	--------------	-------------------	-------	----------

- LEGEND**
-  EXISTING SIGN MOUNTED ON POST(S)
 -  PROPOSED SIGN MOUNTED ON POST(S)
 -  (XXX) DENOTES SIGN NUMBER

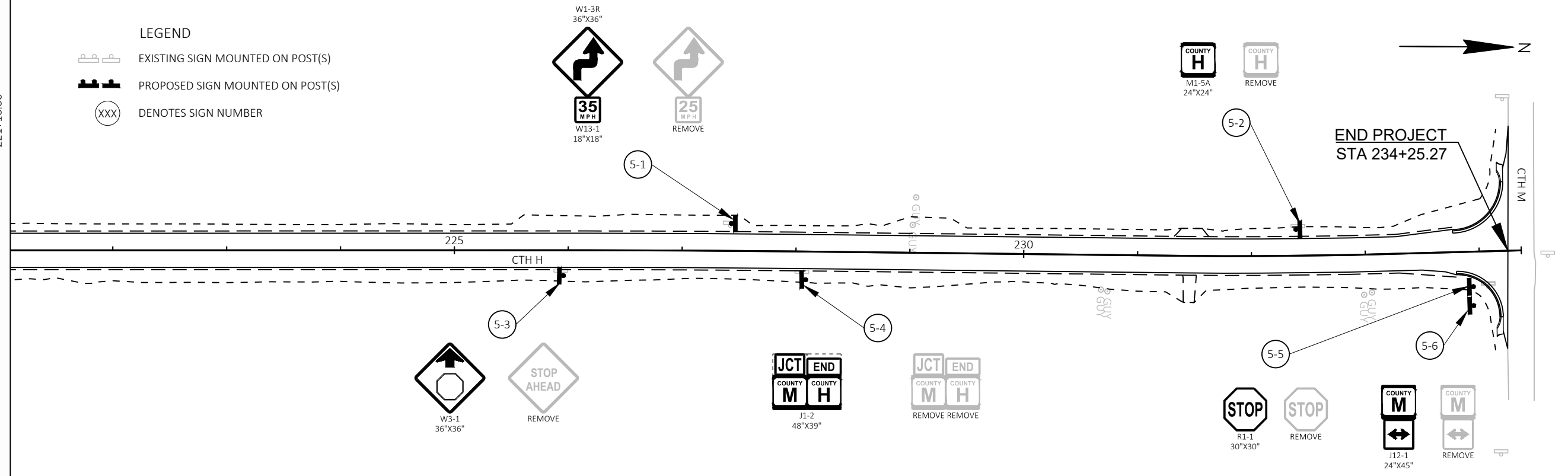
221+10.00



- LEGEND
-  TYPE III BARRICADE
 -  TYPE III BARRICADE WITH ATTACHED SIGN
 -  SIGN ON PERMANENT SUPPORT

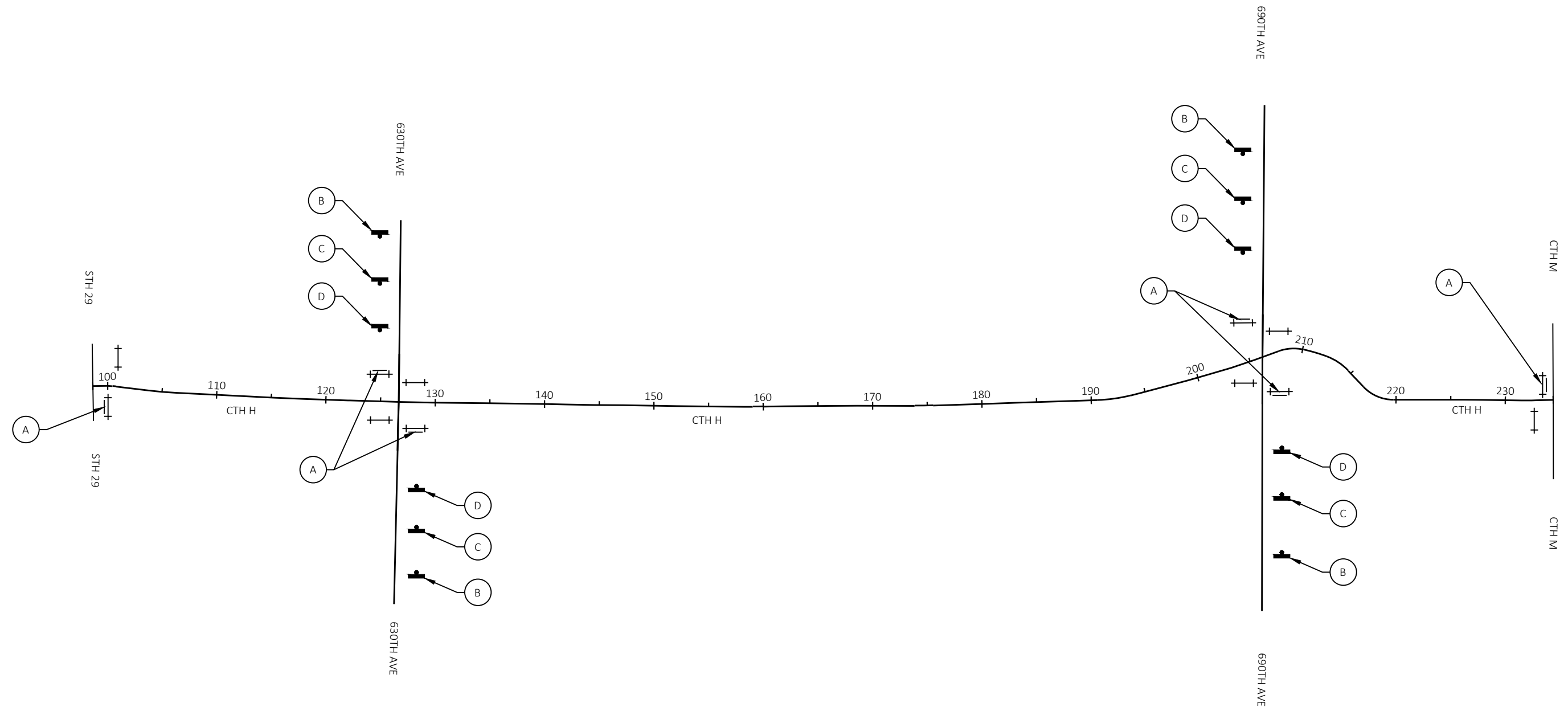
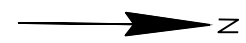

NOTES:

1. THE EXACT NUMBER, LOCATION, AND SPACING OF ALL SIGNS AND DEVICES SHALL BE ADJUSTED TO FIT FIELD CONDITIONS AS DIRECTED BY THE ENGINEER.

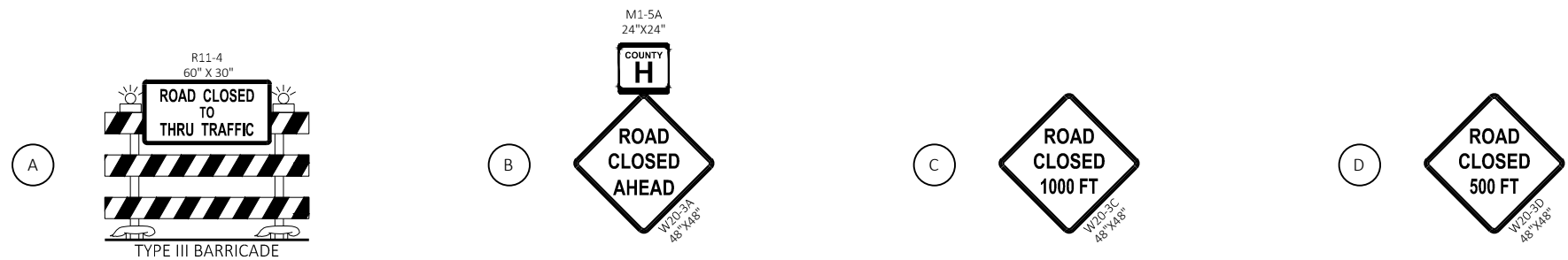

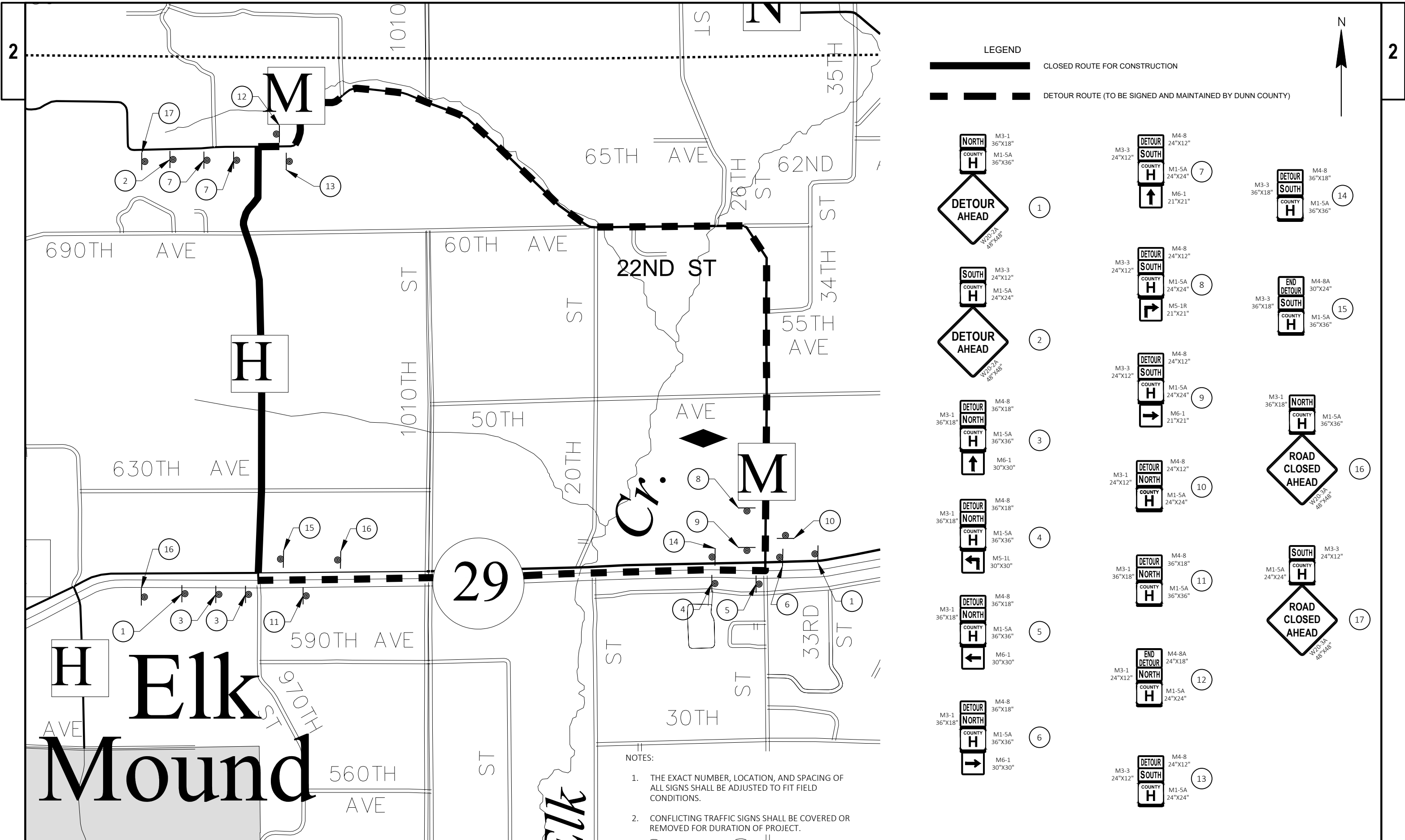

- NOTES:
1. THE EXACT NUMBER, LOCATION, AND SPACING OF ALL SIGNS SHALL BE ADJUSTED TO FIT FIELD CONDITIONS.
 2. CONFLICTING TRAFFIC SIGNS SHALL BE COVERED OR REMOVED FOR DURATION OF PROJECT.

Estimate Of Quantities

7880-07-73

Line	Item	Item Description	Unit	Total	Qty
0002	201.0205	Grubbing	STA	22.000	22.000
0004	203.0100	Removing Small Pipe Culverts	EACH	20.000	20.000
0006	203.0220	Removing Structure (structure) 01. 151+92	EACH	1.000	1.000
0008	204.0110	Removing Asphaltic Surface	SY	270.000	270.000
0010	204.0115	Removing Asphaltic Surface Butt Joints	SY	1,350.000	1,350.000
0012	204.0150	Removing Curb & Gutter	LF	147.000	147.000
0014	204.0165	Removing Guardrail	LF	127.000	127.000
0016	205.0100	Excavation Common	CY	13,990.000	13,990.000
0018	205.0200	Excavation Rock	CY	3,176.000	3,176.000
0020	209.2100	Backfill Granular Grade 2	CY	4,000.000	4,000.000
0022	213.0100	Finishing Roadway (project) 01. 7880-07-73	EACH	1.000	1.000
0024	305.0110	Base Aggregate Dense 3/4-Inch	TON	1,715.000	1,715.000
0026	305.0120	Base Aggregate Dense 1 1/4-Inch	TON	24,905.000	24,905.000
0028	325.0100	Pulverize and Relay	SY	28,730.000	28,730.000
0030	455.0605	Tack Coat	GAL	3,365.000	3,365.000
0032	460.2000	Incentive Density HMA Pavement	DOL	6,880.000	6,880.000
0034	460.5223	HMA Pavement 3 LT 58-28 S	TON	5,375.000	5,375.000
0036	460.5244	HMA Pavement 4 LT 58-34 S	TON	5,375.000	5,375.000
0038	465.0105	Asphaltic Surface	TON	30.000	30.000
0040	465.0120	Asphaltic Surface Driveways and Field Entrances	TON	64.000	64.000
0042	465.0315	Asphaltic Flumes	SY	94.000	94.000
0044	520.1018	Apron Endwalls for Culvert Pipe 18-Inch	EACH	30.000	30.000
0046	520.1024	Apron Endwalls for Culvert Pipe 24-Inch	EACH	14.000	14.000
0048	520.1036	Apron Endwalls for Culvert Pipe 36-Inch	EACH	4.000	4.000
0050	520.3318	Culvert Pipe Class III-A 18-Inch	LF	486.000	486.000
0052	520.3324	Culvert Pipe Class III-A 24-Inch	LF	442.000	442.000
0054	520.3336	Culvert Pipe Class III-A 36-Inch	LF	152.000	152.000
0056	522.0172	Culvert Pipe Reinforced Concrete Class III 72-Inch	LF	50.000	50.000
0058	522.1072	Apron Endwalls for Culvert Pipe Reinforced Concrete 72-Inch	EACH	2.000	2.000
0060	601.0557	Concrete Curb & Gutter 6-Inch Sloped 36-Inch Type D	LF	3,381.000	3,381.000
0062	606.0200	Riprap Medium	CY	40.000	40.000
0064	618.0100	Maintenance And Repair of Haul Roads (project) 01. 7880-07-73	EACH	1.000	1.000
0066	619.1000	Mobilization	EACH	1.000	1.000
0068	624.0100	Water	MGAL	250.000	250.000
0070	625.0500	Salvaged Topsoil	SY	42,585.000	42,585.000
0072	627.0200	Mulching	SY	13,425.000	13,425.000
0074	628.1504	Silt Fence	LF	16,846.000	16,846.000
0076	628.1520	Silt Fence Maintenance	LF	16,846.000	16,846.000
0078	628.1905	Mobilizations Erosion Control	EACH	4.000	4.000
0080	628.1910	Mobilizations Emergency Erosion Control	EACH	4.000	4.000
0082	628.2004	Erosion Mat Class I Type B	SY	22,930.000	22,930.000
0084	628.2006	Erosion Mat Urban Class I Type A	SY	6,230.000	6,230.000
0086	628.7504	Temporary Ditch Checks	LF	345.000	345.000
0088	628.7555	Culvert Pipe Checks	EACH	5.000	5.000
0090	629.0210	Fertilizer Type B	CWT	26.820	26.820
0092	630.0120	Seeding Mixture No. 20	LB	1,160.000	1,160.000
0094	630.0200	Seeding Temporary	LB	1,160.000	1,160.000
0096	630.0500	Seed Water	MGAL	450.000	450.000
0098	633.5200	Markers Culvert End	EACH	24.000	24.000

Estimate Of Quantities

7880-07-73

Line	Item	Item Description	Unit	Total	Qty
0100	634.0614	Posts Wood 4x6-Inch X 14-FT	EACH	10.000	10.000
0102	634.0616	Posts Wood 4x6-Inch X 16-FT	EACH	15.000	15.000
0104	637.2210	Signs Type II Reflective H	SF	105.630	105.630
0106	637.2230	Signs Type II Reflective F	SF	84.000	84.000
0108	638.2102	Moving Signs Type II	EACH	1.000	1.000
0110	638.2602	Removing Signs Type II	EACH	24.000	24.000
0112	638.3000	Removing Small Sign Supports	EACH	25.000	25.000
0114	642.5001	Field Office Type B	EACH	1.000	1.000
0116	643.0300	Traffic Control Drums	DAY	3,060.000	3,060.000
0118	643.0420	Traffic Control Barricades Type III	DAY	1,080.000	1,080.000
0120	643.0705	Traffic Control Warning Lights Type A	DAY	2,160.000	2,160.000
0122	643.0900	Traffic Control Signs	DAY	1,440.000	1,440.000
0124	643.5000	Traffic Control	EACH	1.000	1.000
0126	645.0120	Geotextile Type HR	SY	80.000	80.000
0128	646.1020	Marking Line Epoxy 4-Inch	LF	53,616.000	53,616.000
0130	648.0100	Locating No-Passing Zones	MI	2.570	2.570
0132	650.4500	Construction Staking Subgrade	LF	2,413.000	2,413.000
0134	650.5000	Construction Staking Base	LF	2,413.000	2,413.000
0136	650.5500	Construction Staking Curb Gutter and Curb & Gutter	LF	3,381.000	3,381.000
0138	650.6000	Construction Staking Pipe Culverts	EACH	13.000	13.000
0140	650.9910	Construction Staking Supplemental Control (project) 01. 7880-07-73	LS	1.000	1.000
0142	650.9920	Construction Staking Slope Stakes	LF	13,882.000	13,882.000
0144	690.0150	Sawing Asphalt	LF	605.000	605.000
0146	740.0440	Incentive IRI Ride	DOL	10,160.000	10,160.000
0148	ASP.1T0A	On-the-Job Training Apprentice at \$5.00/HR	HRS	800.000	800.000
0150	ASP.1T0G	On-the-Job Training Graduate at \$5.00/HR	HRS	630.000	630.000

3

CLEARING & GRUBBING

STATION	TO	STATION	LOCATION	*201.0105 CLEARING STA	201.0205 GRUBBING STA
121+00	-	124+00	RT	3	3
130+00	-	132+00	RT/LT	2	2
135+00	-	138+00	LT	3	3
161+00	-	167+00	LT	6	6
178+00	-	181+00	LT	3	3
197+00	-	200+00	LT	3	3
206+00	-	208+00	RT	2	2
				<u>22</u>	<u>22</u>

ASPHALT REMOVAL

STATION	LOCATION	204.0110 REMOVING ASPHALTIC SURFACE SY
102+66	DRIVEWAY RT	23
121+51	DRIVEWAY LT	40
122+27	DRIVEWAY LT	55
155+79	DRIVEWAY RT	44
156+98	DRIVEWAY RT	62
194+81	DRIVEWAY LT	46
		<u>270</u>

ASPHALTIC SURFACE BUTT JOINTS

STATION	LOCATION	204.0115 REMOVING ASPHALTIC SURFACE BUTT JOINTS SY
100+21	BEGIN PROJECT	530
498+54	630TH AVE	100
501+75	630TH AVE	100
798+74	690TH AVE	50
801+03	690TH AVE	50
234+25	END PROJECT	520
TOTAL 0010		<u>1,350</u>

REMOVING CURB & GUTTER

STATION	LOCATION	204.0150 REMOVING CURB & GUTTER LF
100+32	CTH H/CTH HH NW RADIUS	56
100+47	CTH H/CTH HH NE RADIUS	91
		<u>147</u>

PULVERIZE AND RELAY

STATION	TO	STATION	LOCATION	325.0100 PULVERIZE AND RELAY SY
100+21.72	-	123+00	CTH H	5,570
133+50	-	196+50	CTH H	15,400
202+50	-	234+25.27	CTH H	7,760
				<u>28,730</u>

*TO BE COMPLETED BY DUNN COUNTY PRIOR TO CONSTRUCTION

REMOVING OLD STRUCTURES

STATION	LOCATION	203.0220.01 REMOVING STRUCTURE (151+92) EACH	DESCRIPTION
151+92	CTH H	1	1 - 72" X 60' CMCP
			<u>1</u>

REMOVING GUARDRAIL

STATION	TO	STATION	LOCATION	204.0165 REMOVING GUARDRAIL LF
121+20	-	122+47	RT	127
				<u>127</u>

REMOVING SMALL PIPE CULVERTS

STATION	LOCATION	203.0100 REMOVING SMALL PIPE CULVERTS EACH	DESCRIPTION
102+66	DRIVEWAY RT	1	1 - 18" X 30' CMCP
114+56	CTH H	1	1 - 36" X 80' CMCP
125+99	CTH H	1	1 - 18" X 62' CMCP
140+24	DRIVEWAY RT	1	1 - 18" X 30' CMCP
140+83	DRIVEWAY RT	1	1 - 18" X 28' CMCP
146+57	LT	1	1 - 24" X 40' CMCP
148+75	DRIVEWAY RT	1	1 - 18" X 24' CMCP
167+81	CTH H	1	1 - 36" X 50' CMCP
177+55	DRIVEWAY LT	1	1 - 12" X 24' CMCP
181+66	CTH H	1	1 - 18" X 44' CMCP
188+31	CTH H	1	1 - 18" X 56' CMCP
194+13	CTH H	1	1 - 18" X 48' CMCP
195+45	DRIVEWAY RT	1	1 - 15" X 32' CMCP
197+10	DRIVEWAY RT	1	1 - 15" X 30' CMCP
203+25	DRIVEWAY RT	1	1 - 15" X 50' CMCP
204+99	CTH H	1	1 - 18" X 50' CMCP
206+42	CTH H	1	1 - 18" X 54' CMCP
228+63	CTH H	1	1 - 18" X 46' CMCP
499+55	630TH AVE	1	1 - 18" X 50' CMCP
501+12	630TH AVE	1	1 - 18" X 40' CMCP
			<u>20</u>

BACKFILL GRANULAR GRADE 2

STATION	LOCATION	209.2100 BACKFILL GRANULAR GRADE 2 CY	REMARKS
114+56	CTH H	1600	CULVERT REPLACEMENT
125+99	CTH H	600	CULVERT REPLACEMENT
151+92	CTH H	300	CULVERT REPLACEMENT
167+81	CTH H	350	CULVERT REPLACEMENT
181+66	CTH H	100	CULVERT REPLACEMENT
188+31	CTH H	200	CULVERT REPLACEMENT
194+13	CTH H	150	CULVERT REPLACEMENT
204+99	CTH H	100	CULVERT REPLACEMENT
206+42	CTH H	250	CULVERT REPLACEMENT
228+63	CTH H	100	CULVERT REPLACEMENT
499+55	630TH AVE	150	CULVERT REPLACEMENT
501+50	630TH AVE	100	CULVERT REPLACEMENT
TOTAL 0010			<u>4,000</u>

BASE AGGREGATE ITEMS

STATION	TO	STATION	LOCATION	305.0110 BASE AGGREGATE DENSE 3/4-INCH TON	305.0120 BASE AGGREGATE DENSE 1 1/4- INCH TON	624.0100 WATER MGAL	REMARKS
100+21.72	-	123+00	CTH H	--	1,240	--	4" PLACED PRIOR TO PULVERIZING OPERATIONS
123+00	-	136+35	CTH H	--	3,950	--	RECONSTRUCTION BASE
133+50	-	196+50	CTH H	--	3,420	--	4" PLACED PRIOR TO PULVERIZING OPERATIONS
196+50	-	202+50	CTH H	--	1,410	--	RECONSTRUCTION BASE
202+50	-	234+25.27	CTH H	--	1,720	--	4" PLACED PRIOR TO PULVERIZING OPERATIONS
100+21.72	-	123+00	CTH H	--	2,555	--	BASE FOR WIDENING
136+35	-	196+50	CTH H	--	6,750	--	BASE FOR WIDENING
202+50	-	234+25.27	CTH H	--	3,565	--	BASE FOR WIDENING
100+81	-	126+10	CTH H	160	--	--	GRAVEL SHOULDER LT
102+25	-	125+91	CTH H	130	--	--	GRAVEL SHOULDER RT
133+67	-	205+68	CTH H	430	--	--	GRAVEL SHOULDER LT
133+67	-	205+32	CTH H	480	--	--	GRAVEL SHOULDER RT
206+71	-	233+79	CTH H	180	--	--	GRAVEL SHOULDER RT
207+07	-	233+77	CTH H	180	--	--	GRAVEL SHOULDER LT
100+21.72	-	100+65	CTH H/CTH HH	--	75	--	CURB BASE
205+33	-	207+07	CTH H/690TH AVE	--	65	--	CURB BASE
233+77	-	234+25.27	CTH H/CTH M	--	35	--	CURB BASE
DRIVEWAYS				155	120	--	
PROJECT				--	--	250	
				<u>1,715</u>	<u>24,905</u>	<u>250</u>	

3

3

3

DIVISION	FROM/TO STATION	LOCATION	205.0100 COMMON EXCAVATION (1)		SALVAGED/UNUSABLE PAVEMENT MATERIAL (3)	AVAILABLE MATERIAL (4)	205.0200 ROCK EXCAVATION (5)	EXPANDED ROCK FACTOR 1.10 (6)	UNEXPANDED FILL (7)	EXPANDED FILL FACTOR 1.25 (7)	MASS ORDINATE +/- (8)	WASTE
			CUT (2)	EBS EXCAVATION								
DIVISION 1												
CTH H	100+27.72 TO 123+00	MAINLINE	1,542		99	1,443	0	0	3,723	4,654	-3,211	
	123+00 TO 136+35	MAINLINE	2,539		422	2,117	3,176	3,494	1,256	1,570	4,041	
	136+35 TO 196+50	MAINLINE	6,251		256	5,995	0	0	3,994	4,993	1,003	
	196+50 TO 202+50	MAINLINE	1,472		215	1,257	0	0	65	81	1,176	
	202+50 TO 234+25.27	MAINLINE	1,012		170	842	0	0	1,240	1,550	-708	
DIVISION 1 SUBTOTAL			12,816	0	1,162	11,654	3,176	3,494	10,278	12,848	2,300	2,300
DIVISION 2												
630TH AVE	498+54 TO 501+75	630TH AVE	486		128	358	0	0	919	1,149	-791	
690TH AVE	798+74 TO 801+03	690TH AVE	688		83	605	0	0	523	654	-49	
DIVISION 2 SUBTOTAL			1,174	0	211	963	0	0	1,442	1,803	-840	
GRAND TOTAL			13,990	0	1,373	12,617	3,176	3,494	11,720	14,650	1,460	2,833
TOTAL COMMON EXC			13,990									

NOTES:

- (1) COMMON EXCAVATION IS THE SUM OF THE CUT AND EBS EXCAVATION COLUMNS. ITEM NUMBER 205.0100
- (2) SALVAGED/UNUSABLE PAVEMENT MATERIAL IS INCLUDED IN CUT.
- (3) SALVAGED/UNUSABLE PAVEMENT MATERIAL
- (4) AVAILABLE MATERIAL = CUT - SALVAGED/UNUSABLE PAVEMENT MATERIAL
- (5) ROCK EXCAVATION ITEM NUMBER 205.0200
- (6) EXPANDED ROCK FACTOR = 1.10
- (7) EXPANDED FILL FACTOR = 1.25
- (8) THE MASS ORDINATE + OR - QTY CALCULATED FOR THE DIVISION. PLUS QUANTITY INDICATES AN EXCESS OF MATERIAL WITHIN THE DIVISION. MINUS INDICATES A SHORTAGE OF MATERIAL WITHIN THE DIVISION.
- (9) FACTORS USED TO COMPUTE ANTICIPATED WASTE AND THE COMPUTED WASTE VOLUME IDENTIFIED ARE FOR GENERAL INFORMATION ONLY.

HMA ITEMS

STATION	TO	STATION	LOCATION	455.0605 TACK COAT GAL	460.5223 HMA PAVEMENT 3 LT 58-28 S TON	460.5244 HMA PAVEMENT 4 LT 58-34 S TON
100+21.72	-	123+00	CTH H	560	895	895
123+00	-	136+35	CTH H	340	545	545
133+50	-	196+50	CTH H	1,405	2,245	2,245
196+50	-	202+50	CTH H	150	240	240
202+50	-	234+25.27	CTH H	765	1,220	1,220
498+54	-	501+75	630TH AVE	80	130	130
798+74	-	801+03	690TH AVE	65	100	100
				3,365	5,375	5,375

ASPHALTIC SURFACE

STATION	TO	STATION	LOCATION	465.0105 ASPHALTIC SURFACE TON	REMARKS
207+00	-	214+00	CTH H RT	30	FULL WIDTH OF EXPOSED AGGREGATE
				30	

ASPHALT DRIVEWAYS

STATION	LOCATION	TON
102+66	DRIVEWAY RT	5
121+51	DRIVEWAY LT	9
122+27	DRIVEWAY LT	12
155+79	DRIVEWAY RT	10
156+98	DRIVEWAY RT	14
194+81	DRIVEWAY LT	10
197+09	DRIVEWAY RT	4
		64

ASPHALT FLUMES

STATION	LOCATION	465.0315 ASPHALTIC FLUMES SY	606.0200 RIPRAP MEDIUM CY	645.0120 GEOTEXTILE TYPE HR SY
100+35	NE QUADRANT CTH HH	5	--	--
100+75	NW QUADRANT CTH HH	5	--	--
116+86	CTH H LT	5	5	10
122+80	CTH H LT	5	--	--
499+10	NW QUADRANT 630TH AVE	5	5	10
499+35	SW QUADRANT 630TH AVE	5	5	10
500+65	NE QUADRANT 630TH AVE	5	5	10
500+85	SE QUADRANT 630TH AVE	5	5	10
128+80	CTH H RT	5	5	10
128+80	CTH H LT	5	5	10
133+55	CTH H RT	7	--	--
133+55	CTH H LT	7	--	--
196+45	CTH H RT	5	5	10
202+55	CTH H RT	5	--	--
799+10	NE QUADRANT 690TH AVE	5	--	--
800+60	NW QUADRANT 690TH AVE	5	--	--
234+15	SW QUADRANT CTH M	5	--	--
234+15	SE QUADRANT CTH M	5	--	--
		94	40	80

3

3

CURB AND GUTTER ITEMS

601.0557
CONCRETE CURB
& GUTTER 6-
INCH SLOPED 36-
INCH TYPE D

STATION	TO	STATION	LOCATION	LF
BEGIN PROJECT	-	102+25	CTH H/CTH HH RT	222
BEGIN PROJECT	-	100+65	CTH H/CTH HH NW QUADRANT	70
117+00	-	122+75	CTH H LT	575
125+92	-	126+51	630TH AVE SE QUADRANT	91
126+11	-	126+50	630TH AVE SW QUADRANT	60
126+81	-	133+50	CTH H/630 TH AVE RT	688
126+81	-	133+50	CTH H/630 TH AVE LT	699
196+50	-	202+50	CTH H RT	601
205+33	-	205+75	690TH AVE SE QUADRANT	83
205+68	-	206+25	690TH AVE SW QUADRANT	71
206+15	-	206+71	690TH AVE NE QUADRANT	10
206+65	-	207+07	690TH AVE NW QUADRANT	83
233+77	-	END PROJECT	CTH M SW QUADRANT	67
233+79	-	END PROJECT	CTH M SE QUADRANT	61
				3,381

CULVERT PIPE ITEMS

STATION	LOCATION	520.1018 APRON ENDWALLS FOR CULVERT PIPE 18- INCH EACH	520.1024 APRON ENDWALLS FOR CULVERT PIPE 24- INCH EACH	520.1036 APRON ENDWALLS FOR CULVERT PIPE 36- INCH EACH	520.3318 CULVERT PIPE CLASS III-A 18- INCH LF	520.3324 CULVERT PIPE CLASS III-A 24- INCH LF	520.3336 CULVERT PIPE CLASS III-A 36- INCH LF	522.0172 CULVERT PIPE REINFORCED CONCRETE CLASS III 72-INCH LF	522.1072 APRON ENDWALLS FOR CULVERT PIPE REINFORCED CONCRETE 72- INCH EACH	633.5200 MARKERS CULVERT END EACH	650.6000 CONSTRUCTION STAKING PIPE CULVERTS EACH
107+95	DRIVEWAY LT	2	--	--	28	--	--	--	--	--	--
114+56	CTH H	--	--	2	--	--	102	--	--	2	1
125+99	CTH H	--	2	--	--	76	--	--	--	2	1
140+24	RT	2	--	--	30	--	--	--	--	--	1
140+83	DRIVEWAY RT	2	--	--	30	--	--	--	--	--	--
142+25	DRIVEWAY LT	2	--	--	24	--	--	--	--	--	--
146+57	DRIVEWAY LT	2	--	--	40	--	--	--	--	--	--
148+75	DRIVEWAY RT	2	--	--	26	--	--	--	--	--	--
151+92	CTH H	--	--	--	--	--	--	50	2	2	1
160+50	DRIVEWAY LT	2	--	--	22	--	--	--	--	--	--
167+81	CTH H	--	--	2	--	--	50	--	--	2	1
175+45	DRIVEWAY RT	2	--	--	34	--	--	--	--	--	--
176+95	DRIVEWAY RT	2	--	--	30	--	--	--	--	--	--
177+55	DRIVEWAY LT	2	--	--	28	--	--	--	--	--	--
181+66	CTH H	--	2	--	--	42	--	--	--	2	1
188+31	CTH H	--	2	--	--	54	--	--	--	2	1
194+13	CTH H	--	2	--	--	52	--	--	--	2	1
195+45	DRIVEWAY RT	2	--	--	32	--	--	--	--	--	--
203+25	DRIVEWAY RT	2	--	--	50	--	--	--	--	--	--
204+99	CTH H	2	--	--	50	--	--	--	--	2	1
206+42	CTH H	--	2	--	--	100	--	--	--	2	1
228+63	CTH H	--	2	--	--	46	--	--	--	2	1
499+55	630TH AVE	--	2	--	--	72	--	--	--	2	1
501+10	DRIVEWAY LT	2	--	--	22	--	--	--	--	--	--
501+50	630TH AVE	2	--	--	40	--	--	--	--	2	1
		30	14	4	486	442	152	50	2	24	13

SILT FENCE ITEMS

STATION	TO	STATION	LOCATION	628.1504 SILT FENCE LF	628.1520 SILT FENCE MAINTENANCE LF
104+45	-	107+60	RT	324	324
112+50	-	117+00	RT	422	422
112+50	-	117+00	LT	444	444
119+85	-	126+40	RT	807	807
122+50	-	126+40	LT	435	435
126+90	-	129+00	LT	260	260
127+05	-	128+45	RT	162	162
133+45	-	155+25	LT	2,170	2,170
142+10	-	143+90	RT	180	180
148+90	-	158+65	RT	983	983
160+09	-	170+90	RT	1,093	1,093
160+55	-	172+50	LT	1,200	1,200
177+00	-	178+50	RT	153	153
179+95	-	182+30	RT	235	235
180+25	-	189+90	LT	979	979
186+65	-	196+55	RT	969	969
192+24	-	197+50	LT	520	520
200+25	-	206+50	LT	665	665
202+50	-	206+00	RT	335	335
206+60	-	225+50	LT	1,965	1,965
209+50	-	212+40	RT	290	290
217+40	-	234+25	RT	1,753	1,753
229+50	-	234+25	LT	502	502
				16,846	16,846

PROJECT NO: 7880-07-73

HWY: CTH H

COUNTY: DUNN

MISCELLANEOUS QUANTITIES

SHEET

E

EROSION CONTROL ITEMS

STATION	TO	STATION	LOCATION	625.0500 SALVAGED TOPSOIL SY	627.0200 MULCHING SY	628.2004 EROSION MAT CLASS I TYPE B SY	628.2006 EROSION MAT URBAN CLASS I TYPE A SY	628.7504 TEMPORARY DITCH CHECKS LF	628.7555 CULVERT PIPE CHECKS EACH	629.0210 FERTILIZER TYPE B CWT	630.0120 SEEDING MIXTURE NO. 20 LB	630.0200 SEEDING TEMPORARY LB	630.0500 SEED WATER MGAL	REMARKS
100+22	-	126+54	LT	5915	460	4050	1405	--	--	3.73	160	160	--	BEGIN PROJECT TO 630TH AVE
100+22	-	126+56	RT	5720	560	3430	1730	--	--	3.60	155	155	--	BEGIN PROJECT TO 630TH AVE
		112+22	LT	--	--	--	--	15	--	--	--	--	--	BEGIN PROJECT TO 630TH AVE
126+75	-	206+50	LT	12755	4485	7375	895	--	--	8.04	345	345	--	630TH AVE TO 690TH AVE
126+76	-	205+73	RT	11130	2920	6010	2200	--	--	7.01	305	305	--	630TH AVE TO 690TH AVE
		134+97	RT	--	--	--	--	15	--	--	--	--	--	630TH AVE TO 690TH AVE
		138+40	RT	--	--	--	--	15	--	--	--	--	--	630TH AVE TO 690TH AVE
		139+87	RT	--	--	--	--	--	1	--	--	--	--	630TH AVE TO 690TH AVE
		141+56	RT	--	--	--	--	15	--	--	--	--	--	630TH AVE TO 690TH AVE
		148+50	RT	--	--	--	--	--	1	--	--	--	--	630TH AVE TO 690TH AVE
		155+30	LT	--	--	--	--	15	--	--	--	--	--	630TH AVE TO 690TH AVE
		156+60	LT	--	--	--	--	15	--	--	--	--	--	630TH AVE TO 690TH AVE
		158+50	LT	--	--	--	--	15	--	--	--	--	--	630TH AVE TO 690TH AVE
		161+42	LT	--	--	--	--	15	--	--	--	--	--	630TH AVE TO 690TH AVE
		163+42	LT	--	--	--	--	15	--	--	--	--	--	630TH AVE TO 690TH AVE
		165+42	LT	--	--	--	--	15	--	--	--	--	--	630TH AVE TO 690TH AVE
		166+78	LT	--	--	--	--	15	--	--	--	--	--	630TH AVE TO 690TH AVE
		171+08	RT	--	--	--	--	15	--	--	--	--	--	630TH AVE TO 690TH AVE
		172+89	RT	--	--	--	--	15	--	--	--	--	--	630TH AVE TO 690TH AVE
		173+04	LT	--	--	--	--	15	--	--	--	--	--	630TH AVE TO 690TH AVE
		174+64	RT	--	--	--	--	15	--	--	--	--	--	630TH AVE TO 690TH AVE
		175+02	LT	--	--	--	--	15	--	--	--	--	--	630TH AVE TO 690TH AVE
		177+31	LT	--	--	--	--	--	1	--	--	--	--	630TH AVE TO 690TH AVE
		182+48	RT	--	--	--	--	15	--	--	--	--	--	630TH AVE TO 690TH AVE
		190+70	LT	--	--	--	--	15	--	--	--	--	--	630TH AVE TO 690TH AVE
		195+22	RT	--	--	--	--	--	1	--	--	--	--	630TH AVE TO 690TH AVE
		203+97	RT	--	--	--	--	--	1	--	--	--	--	630TH AVE TO 690TH AVE
205+94	-	234+25	RT	3925	2090	1835	--	--	--	2.47	110	110	--	690TH AVE TO END PROJECT
206+70	-	234+25	LT	3140	2910	230	--	--	--	1.98	85	85	--	690TH AVE TO END PROJECT
		206+94	RT	--	--	--	--	15	--	--	--	--	--	690TH AVE TO END PROJECT
		208+60	RT	--	--	--	--	15	--	--	--	--	--	690TH AVE TO END PROJECT
		215+00	RT	--	--	--	--	15	--	--	--	--	--	690TH AVE TO END PROJECT
		216+70	RT	--	--	--	--	15	--	--	--	--	--	690TH AVE TO END PROJECT
		227+42	LT	--	--	--	--	15	--	--	--	--	--	690TH AVE TO END PROJECT
100+21	-	234+25	LT AND RT	--	--	--	--	--	--	--	--	--	450	
				42,585	13,425	22,930	6,230	345	5	26.82	1,160	1,160	450	

TRAFFIC CONTROL

LOCATION	643.0300 TRAFFIC CONTROL DRUMS DAY	643.0420 TRAFFIC CONTROL BARRICADES TYPE III DAY	643.0705 TRAFFIC CONTROL WARNING LIGHTS TYPE A DAY	643.0900 TRAFFIC CONTROL SIGNS DAY
CTH H	3,060	1,080	2,160	1,440
TOTAL 0010	3,060	1,080	2,160	1,440

CONSTRUCTION STAKING ITEMS

STATION	TO	STATION	LOCATION	650.4500 CONSTRUCTION STAKING SUBGRADE LF	650.5000 CONSTRUCTION STAKING BASE LF	650.9910. CONSTRUCTION STAKING SUPPLEMENTAL CONTROL (PROJECT) (7880- 07-73) LS	650.9920 CONSTRUCTION STAKING SLOPE STAKES LF	REMARKS
100+21	-	123+00	CTH H	--	--	--	2,279	PULVERIZE AND RELAY
123+00	-	136+35	CTH H	1,335	1,335	--	1,335	RECONSTRUCTION
136+35	-	196+50	CTH H	--	--	--	6,015	PULVERIZE AND RELAY
196+50	-	202+50	CTH H	600	600	--	600	RECONSTRUCTION
202+50	-	234+25	CTH H	--	--	--	3,175	PULVERIZE AND RELAY
498+54	-	501+03	630TH AVE	249	249	--	249	RECONSTRUCTION
798+74	-	801+03	690TH AVE	229	229	--	229	RECONSTRUCTION
			PROJECT	--	--	1	--	
TOTAL 0010				2,413	2,413	1	13,882	

CONST STAKE CURB AND GUTTER

STATION	TO	STATION	LOCATION	650.5500 CONSTRUCTION STAKING CURB GUTTER AND CURB & GUTTER LF
BEGIN PROJECT	-	102+25	CTH H/CTH HH RT	222
BEGIN PROJECT	-	100+65	CTH H/CTH HH NW QUADRANT	70
117+00	-	122+75	CTH H LT	575
125+92	-	126+51	630TH AVE SE QUADRANT	91
126+11	-	126+50	630TH AVE SW QUADRANT	60
126+81	-	133+50	CTH H/630 TH AVE RT	688
126+81	-	133+50	CTH H/630 TH AVE LT	699
196+50	-	202+50	CTH H RT	601
205+33	-	205+75	690TH AVE SE QUADRANT	83
205+68	-	206+25	690TH AVE SW QUADRANT	71
206+15	-	206+71	690TH AVE NE QUADRANT	10
206+65	-	207+07	690TH AVE NW QUADRANT	83
233+77	-	END PROJECT	CTH M SW QUADRANT	67
233+79	-	END PROJECT	CTH M SE QUADRANT	61
TOTAL 0010				3,381

SAWING ASPHALT

STATION	LOCATION	690.0150 SAWING ASPHALT LF
100+21.72	BEING PROJECT	170
102+66	DRIVEWAY RT	20
121+50	DRIVEWAY LT	39
122+25	DRIVEWAY LT	45
498+54	630TH AVE	22
501+75	630TH AVE	22
155+80	DRIVEWAY RT	11
157+00	DRIVEWAY RT	12
194+81	DRIVEWAY LT	12
197+10	DRIVEWAY RT	15
798+94	690TH AVE	20
801+03	690TH AVE	20
234+25.27	END PROJECT	197
		605

PAVEMENT MARKINGS

STATION	TO	STATION	LOCATION	646.1020 MARKING LINE EPOXY 4-INCH LF
100+21	-	234+25	CL	26,808
100+21	-	234+25	LT AND RT	26,808
TOTAL 0010				53,616

CONVENTIONAL SYMBOLS

SECTION LINE	--- ---	PARCEL NUMBER	25	UTILITY NUMBER	40
QUARTER LINE	---	SECTION CORNER		R/W MONUMENT	●
SIXTEENTH LINE	---	NOTATION FOR COMBUSTIBLE FLUIDS		NON-MONUMENTED R/W POINT	○
NEW REFERENCE LINE	---	NOTATION FOR HIGH VOLTAGE TRANSMISSION LINES		FOUND IRON PIN	IP
NEW R/W LINE	---			VALVE (GAS, WATER, ETC.)	⊙ (TYPE)
EXISTING R/W LINE	---			SIGN	⊥ SIGN
PROPERTY LINE	---			OFF-PREMISE SIGN	
LOT, TIE, AND OTHER MINOR LINES	---				
SLOPE INTERCEPT	///				
CORPORATE LIMITS	---				
UNDERGROUND FACILITY (COMMUNICATIONS, ELECTRIC, ETC.)	---				
FEE ACQUISITION AREA (HATCHING VARIES BY OWNER)					

TEMP. LIMITED EASEMENT AREA		ACCESS CONTROLLED BY ACQUISITION	
EASEMENT AREA (HIGHWAY, PERMANENT LIMITED, OR RESTRICTED DEVELOPMENT)		NO ACCESS (BY STATUTORY AUTHORITY)	●●●●●
TRANSMISSION STRUCTURES		ACCESS RESTRICTED (BY PREVIOUS PROJECT OR CONTROL)	▲▲▲▲▲
BUILDING		NO ACCESS (NEW HIGHWAY)	▲▲▲▲▲
BUILDING (TO BE REMOVED)		NATIONAL GEODETIC SURVEY MONUMENT	⊙
BRIDGE		SIXTEENTH CORNER MONUMENT	⊙
		PARALLEL OFFSETS	

CONVENTIONAL UTILITY SYMBOLS

WATER	---
GAS	---
TELEPHONE	---
OVERHEAD TRANSMISSION LINES	---
ELECTRIC	---
CABLE TELEVISION	---
FIBER OPTIC	---
SANITARY SEWER	---
STORM SEWER	---
ELECTRIC TOWER	⊙

CURVE DATA ABBREVIATIONS

LONG CHORD	LCH
LONG CHORD BEARING	LCB
RADIUS	R
DEGREE OF CURVE	D
CENTRAL ANGLE	Δ/DELTA
LENGTH OF CURVE	L
TANGENT	T
DIRECTION AHEAD	DA
DIRECTION BACK	DB

CONVENTIONAL ABBREVIATIONS

ACCESS RIGHTS	AR	OUTLOT	OL
ACRES	AC	PAGE	P
AHEAD	AH	POINT OF TANGENCY	PT
ALUMINUM	ALUM	PROPERTY LINE	PL
AND OTHERS	ETAL	RECORDED AS (100')	(100')
BACK	BK	REEL / IMAGE	R/I
BLOCK	BLK	REFERENCE LINE	R/L
CENTERLINE	C/L	PERMANENT LIMITED EASEMENT	PLE
CERTIFIED SURVEY MAP	CSM	POINT OF BEGINNING	POB
CONCRETE	CONC	POINT OF CURVATURE	PC
COUNTY	CO	POINT OF COMPOUND CURVE	PCC
COUNTY TRUNK HIGHWAY	CTH	POINT OF INTERSECTION	PI
DISTANCE	DIST	REMAINING	REM
CORNER	COR	RESTRICTIVE DEVELOPMENT EASEMENT	RDE
DOCUMENT NUMBER	DOC	RIGHT	RT
EASEMENT	EASE	RIGHT OF WAY	R/W
EXISTING	EX	SECTION	SEC
GAS VALVE	GV	SEPTIC VENT	SEPV
GRID NORTH	GN	SQUARE FEET	SF
HIGHWAY EASEMENT	HE	STATE TRUNK HIGHWAY	STH
IDENTIFICATION	ID	STATION	STA
LAND CONTRACT	LC	TELEPHONE PEDESTAL	TP
LEFT	LT	TEMPORARY LIMITED EASEMENT	TLE
MONUMENT	MON	TRANSPORTATION PROJECT PLAT	TPP
NATIONAL GEODETIC SURVEY NUMBER	NGS	UNITED STATES HIGHWAY	USH
	NO	VOLUME	V

CONVENTIONAL ABBREVIATIONS

ACCESS RIGHTS	AR	OUTLOT	OL
ACRES	AC	PAGE	P
AHEAD	AH	POINT OF TANGENCY	PT
ALUMINUM	ALUM	PROPERTY LINE	PL
AND OTHERS	ETAL	RECORDED AS (100')	(100')
BACK	BK	REEL / IMAGE	R/I
BLOCK	BLK	REFERENCE LINE	R/L
CENTERLINE	C/L	PERMANENT LIMITED EASEMENT	PLE
CERTIFIED SURVEY MAP	CSM	POINT OF BEGINNING	POB
CONCRETE	CONC	POINT OF CURVATURE	PC
COUNTY	CO	POINT OF COMPOUND CURVE	PCC
COUNTY TRUNK HIGHWAY	CTH	POINT OF INTERSECTION	PI
DISTANCE	DIST	REMAINING	REM
CORNER	COR	RESTRICTIVE DEVELOPMENT EASEMENT	RDE
DOCUMENT NUMBER	DOC	RIGHT	RT
EASEMENT	EASE	RIGHT OF WAY	R/W
EXISTING	EX	SECTION	SEC
GAS VALVE	GV	SEPTIC VENT	SEPV
GRID NORTH	GN	SQUARE FEET	SF
HIGHWAY EASEMENT	HE	STATE TRUNK HIGHWAY	STH
IDENTIFICATION	ID	STATION	STA
LAND CONTRACT	LC	TELEPHONE PEDESTAL	TP
LEFT	LT	TEMPORARY LIMITED EASEMENT	TLE
MONUMENT	MON	TRANSPORTATION PROJECT PLAT	TPP
NATIONAL GEODETIC SURVEY NUMBER	NGS	UNITED STATES HIGHWAY	USH
	NO	VOLUME	V

NOTES:

POSITIONS SHOWN ON THIS PLAT ARE WISCONSIN COORDINATE REFERENCE SYSTEM COORDINATES (WISCRS), DUNN COUNTY, NAD 83 (2011) IN US SURVEY FEET. VALUES SHOWN ARE GRID COORDINATES, GRID BEARINGS, AND GRID DISTANCES. GRID DISTANCES MAY BE USED AS GROUND DISTANCES.

RIGHT OF WAY MONUMENTS ARE REBAR AND ARE PLACED PRIOR TO THE COMPLETION OF THE PROJECT.

RIGHT OF WAY BOUNDARIES ARE DEFINED WITH COURSES OF THE PERIMETER OF THE HIGHWAY LANDS REFERENCED TO THE U.S. PUBLIC LAND SURVEY OR OTHER SURVEYS OF PUBLIC RECORD.

CAUTION:
THIS PLAT IS FOR ILLUSTRATIVE PURPOSES ONLY. DEEDS MUST BE CHECKED TO DETERMINE PROPERTY BOUNDARIES.

R/W PROJECT NUMBER 7880-07-03	SHEET NUMBER 4.01	TOTAL SHEETS 4.08
CONSTRUCTION PROJECT NUMBER 7880-07-73		
PLAT OF RIGHT OF WAY REQUIRED FOR CARYVILLE - CTH M CTH HH TO CTH M		
CTH H	DUNN COUNTY	

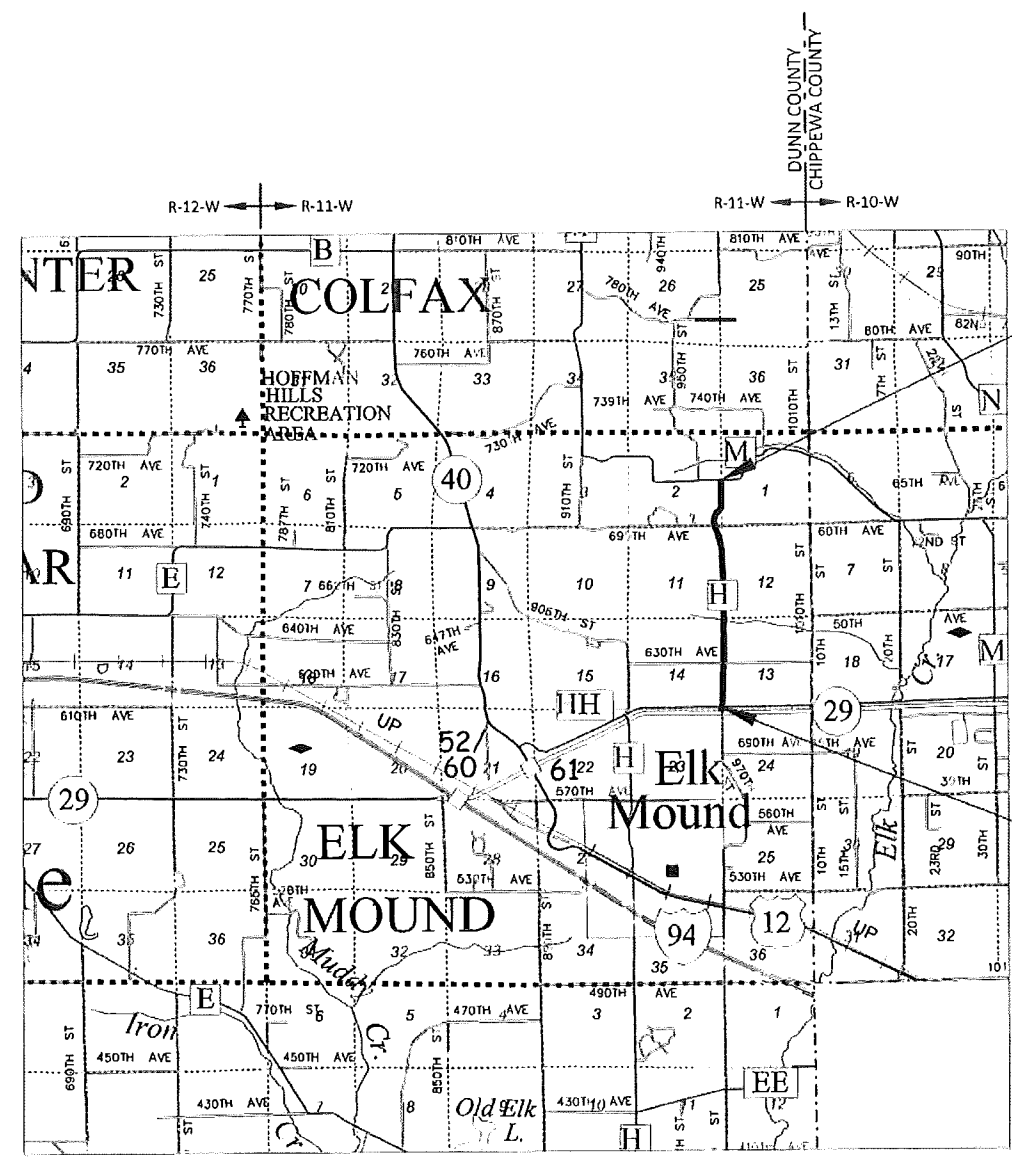

END RELOCATION ORDER
STA 234+36.96
Y = 192,380.59
X = 227,906.42
17.70' EAST AND 7.22' SOUTH
OF THE EAST QUARTER OF
SEC 2, T-28-N, R-11-W

BEGIN RELOCATION ORDER
STA 105+00.00
Y = 179,659.90
X = 227,946.12
1.99' WEST AND 464.61' NORTH OF
THE SOUTHWEST CORNER OF
SEC 13, T-28-N, R-11-W

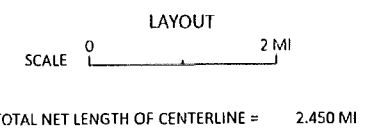

CORRE ENGINEERING
MADISON | COCONONGOC | EAU CLAIRE | GREEN BAY | WITTMENBERG

WISCONSIN
BRYON J. MOTSZKO
S-2846
MENOMONIE
WI
LAND SURVEYOR

1. BRYON J. MOTSZKO, PROFESSIONAL LAND SURVEYOR, S-2846, HEREBY CERTIFY THAT I HAVE SURVEYED THE LAND DESCRIBED HEREON AND THAT THE MAP HEREON IS A CORRECT REPRESENTATION OF THAT SURVEY TO THE BEST OF MY KNOWLEDGE AND BELIEF.

DATE: 4/2/21 *Bryon J. Motzko* (signature)

DUNN COUNTY

APPROVED FOR THE COUNTY

DATE: 4/5/21 *[Signature]* (signature)

REVISION DATE
5/19/21
8/24/21

SCHEDULE OF LANDS & INTERESTS REQUIRED

OWNERS NAMES ARE SHOWN FOR REFERENCE ONLY AND ARE SUBJECT TO CHANGE PRIOR TO THE TRANSFER OF LAND INTERESTS TO THE COUNTY.

PARCEL NUMBER	SHEET NUMBER	OWNER	INTEREST REQUIRED	R-W ACRES REQUIRED			TLE ACRES REQUIRED
				NEW (AC)	EXISTING (AC)	TOTAL (AC)	TOTAL (AC)
1	4.04	NORMAN D. OLSON	FEE / TLE	0.46	1.00	1.46	0.04
2	4.04	FOREST VIEW ACRES, INC.	FEE	0.57	1.49	2.06	---
3	4.04	TOWN OF ELK MONUD	FEE	---	0.22	0.22	---
4	4.04	THE BARUM NORWEGAIN LUTHERN CHURCH	FEE / TLE	---	0.07	0.07	0.03
5	4.04	BARUM LUTHERN CHURCH	FEE / TLE	---	0.11	0.11	0.02
6	4.05	FREDERICK WC HABERBURG & WENDY S. HABERBERG	FEE	0.11	0.44	0.55	---
7	4.05	JOHN THOMAS & JENNY L. LARSON	FEE	0.05	0.22	0.27	0.13
8	4.05	KEITH R. & KRISTIN A. HANSON	FEE	0.08	0.23	0.31	---
9	4.05	JOYCE M. HANSON REVOCABLE GRANTOR TRUST	TLE	---	---	---	0.03
10	4.05	LYNN E. & RUTH E. SMITH	TLE	---	---	---	0.03
11	4.05, 4.06	TRUST AGREEMENT OF VERN & RUTH HANSON	FEE / TLE	0.52	1.70	2.22	0.11
12	4.05	EDWARD ROBERT & ADAM LEE BLASKOWSKI	TLE	---	---	---	0.05
13	4.06	D&P RHUDE, LLC.	FEE	0.04	0.76	0.80	---
14	4.06	PATRICK A. & LANETTE M. RHUDE	FEE	0.27	0.76	1.03	---
15	4.06	MICHAEL H. & JANET S. BRUNNER	FEE	0.08	0.14	0.22	---
16	4.07	DAVID E. RHUDE	TLE	---	---	---	0.02
17	4.07	DEAN R. & LEAH R. LANGBY	TLE	---	---	---	0.06
18	4.07	DENNIS W. & DAWN M. CURRY	TLE	---	---	---	0.02
19	4.07	COREY H. & DEBORAH J. SVEE	FEE / TLE	0.01	0.14	0.15	0.04
20	4.07	JEROME P. & JENNIFER A. KIDROWSKI	FEE	0.06	0.17	0.23	---
21	4.08	TERRY J. & CATHERINE S. SVIHOVEC	TLE	---	---	---	0.06
22	4.08	PAMELA S. SOLBERG	FEE / TLE	0.08	0.28	0.36	0.16
80	4.04 - 4.08	DUNN ENERGY COOPERATIVE					RELEASE OF RIGHTS
81	4.04 - 4.08	TELEPHONE USA OF WISCONSIN, LLC					RELEASE OF RIGHTS
82	4.04, 4.07, 4.08	GTE NORTH					RELEASE OF RIGHTS
83	4.05, 4.06	NORTHERN STATES POWER COMPANY					RELEASE OF RIGHTS

4

4

REVISION DATE	5/19/21 8/24/21	DATE : 4/2/21	SCALE, FEET	HWY: CTH H	STATE R/W PROJECT NUMBER 7880-07-03	PLAT SHEET 4.02
		GRID FACTOR		COUNTY: DUNN	CONSTRUCTION PROJECT NUMBER 7880-07-73	PS&E SHEET

4

4

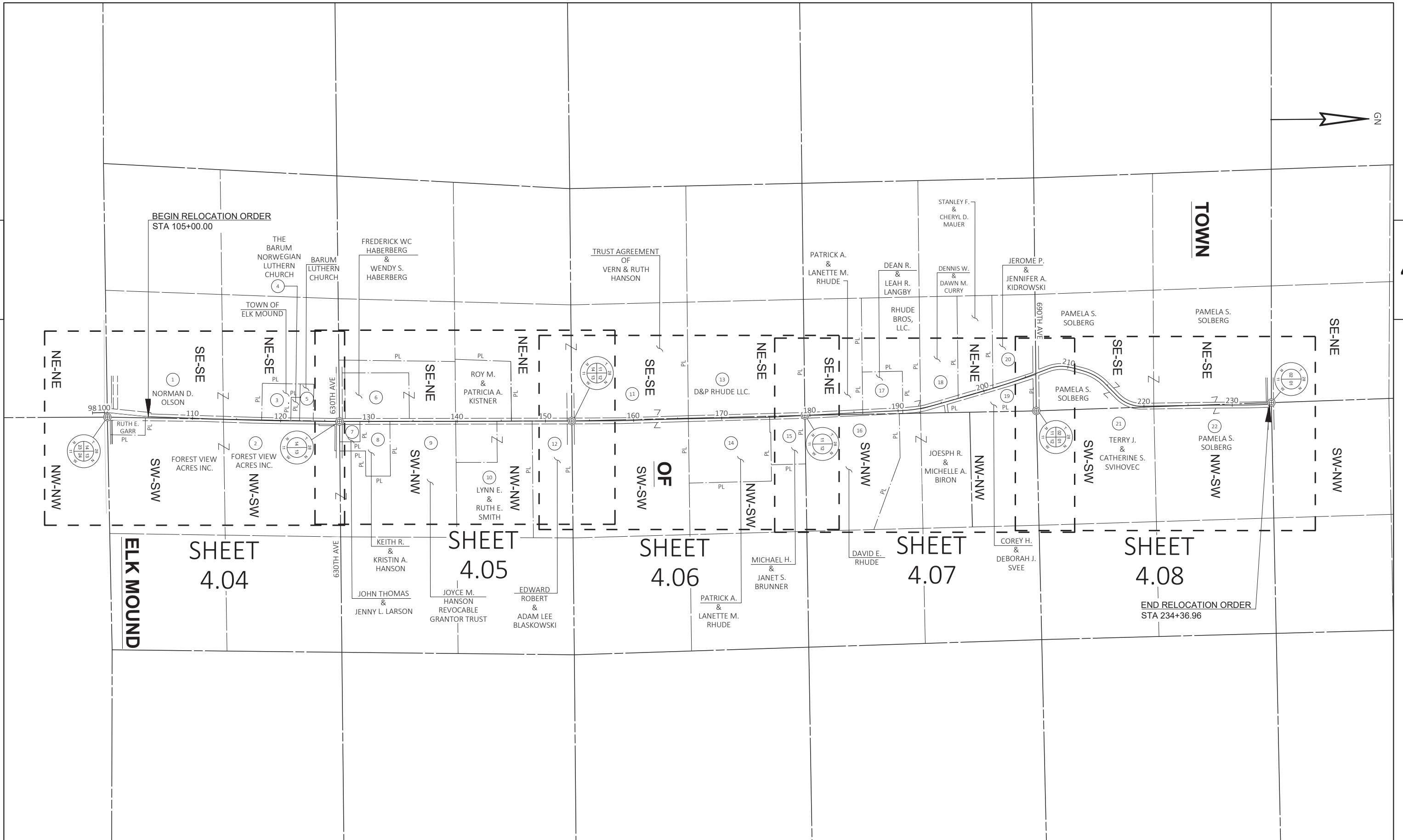

REVISION DATE	5/19/21 - N.C.		
	8/24/21 - N.C.		

DATE : 4/2/21
GRID FACTOR



HWY: CTH H
COUNTY: DUNN

STATE R/W PROJECT NUMBER 7880-07-03
CONSTRUCTION PROJECT NUMBER 7880-07-73

PLAT SHEET 4.03	E
PS&E SHEET	

PI STA = 104+99.68 PI STA = 120+06.63 PI STA = 123+92.17
 Y = 179659.363 Y = 181165.280 Y = 181550.805
 X = 227948.351 X = 228006.474 X = 228011.518
 DELTA = 4°04'19" DELTA = 1°07'03" DELTA = 0°36'56"
 D = 1°35'56" D = 0°17'11" D = 0°10'46"
 T = 127.39' T = 195.06' T = 171.57'
 L = 254.68' L = 390.11' L = 343.15'
 R = 3583.60' R = 20000.00' R = 31939.00'
 PC STA = 103+72.29 PC STA = 118+11.57 PC STA = 122+20.60
 PT STA = 106+26.97 PT STA = 122+01.68 PT STA = 125+63.75

EXISTING UTILITY EASEMENT TO BE RELEASED

- 80 DUNN ENERGY COOPERATIVE**
 PARCEL 1: DOC # 345035
 PARCEL 3: DOC # 194267
 PARCEL 4: DOC # 194267
 PARCEL 5: DOC # 194267
- 81 TELEPHONE USA OF WISCONSIN, LLC (CENTURY LINK)**
 PARCEL 2: DOC # 288848, # 464942
- 82 GTE NORTH (FRONTIER COMMUNICATIONS)**
 PARCEL 2: DOC # 398770

NOTE:
 CTH M R/W ESTABLISHED FROM EXISTING CENTERLINE (WIS STATUTE 82.31) & CSMS ALONG ROADWAY.
 STH 29 R/W (CTH HH) ESTABLISHED FROM WISDOT PROJECT PLAT PLAT 6380 & CSM 530

4

4

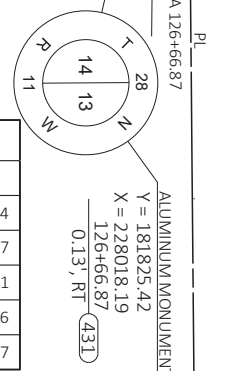
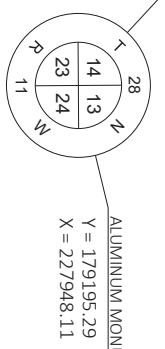
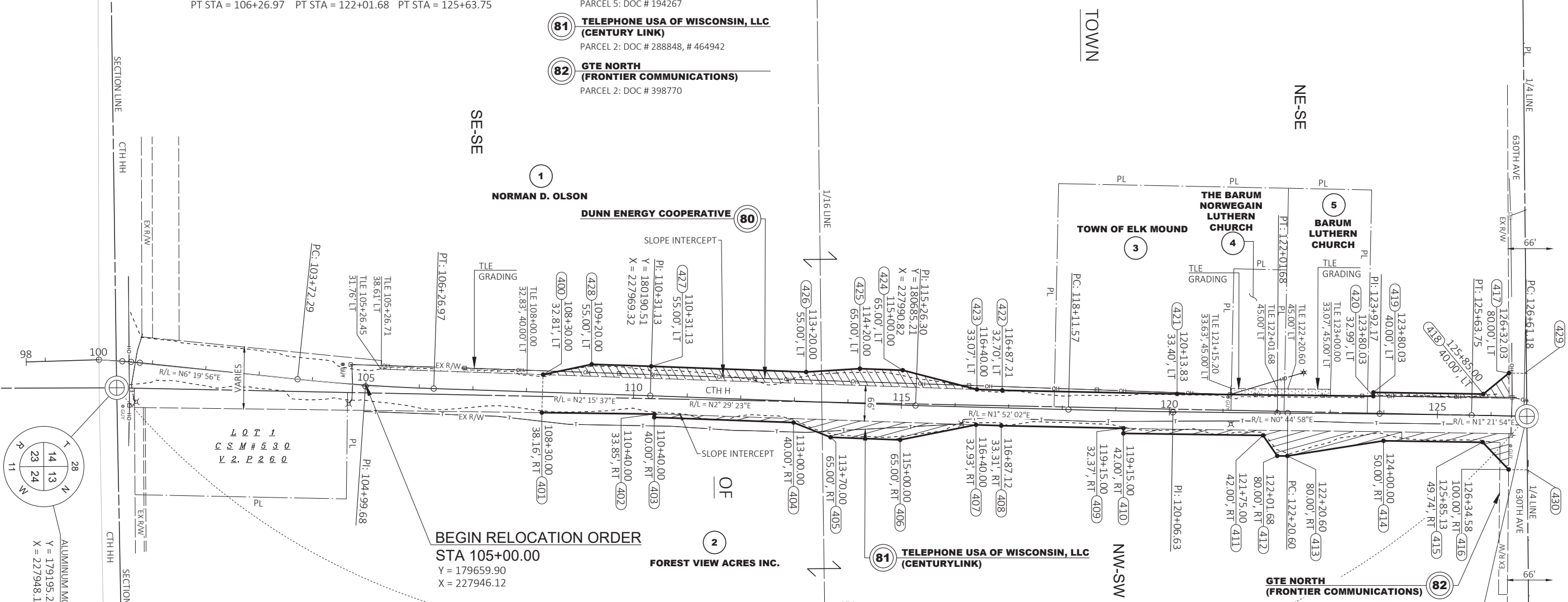

COURSE TABLE

POINT	POINT	BEARING	DISTANCE
400	401	S87° 44' 23"E	70.96'
401	402	N01° 05' 42"E	209.91'
402	403	S87° 30' 38"E	6.15'
403	404	N02° 29' 23"E	260.00'
404	405	N22° 08' 36"E	74.33'
405	406	N02° 29' 23"E	130.00'
406	407	N10° 51' 40"W	144.25'
407	408	N02° 19' 35"E	47.12'
408	409	N01° 33' 50"E	228.05'
409	410	S88° 25' 45"E	9.63'
410	411	N01° 11' 54"E	260.55'
411	412	N55° 38' 11"E	46.48'
412	413	N00° 44' 58"E	18.92'
413	414	N08° 36' 07"W	181.53'
414	415	N01° 09' 19"E	184.87'
415	416	N46° 49' 36"E	70.51'
416	430	N01° 19' 09"E	34.91'
430	431	S89° 51' 32"W	99.88'

COURSE TABLE

POINT	POINT	BEARING	DISTANCE
431	429	S89° 50' 07"W	80.18'
429	417	S01° 19' 28"W	32.69'
417	418	S39° 00' 51"E	61.74'
418	419	S01° 13' 03"W	205.20'
419	420	S88° 57' 52"E	7.01'
420	421	S01° 00' 50"W	366.06'
421	422	S01° 33' 50"W	326.28'
422	423	S02° 19' 35"W	47.21'
423	424	S14° 53' 12"W	142.97'
424	425	S02° 29' 23"W	80.00'
425	426	S03° 13' 16"E	100.50'
426	427	S02° 29' 22"W	289.09'
427	428	S02° 15' 37"W	111.13'
428	400	S11° 35' 33" E	92.70'

POINT TABLE

POINT	Y	X
400	179990.82	227928.60
401	179988.03	227999.51
402	180197.90	228003.52
403	180197.63	228009.66
404	180457.38	228020.96
405	180526.23	228048.97
406	180656.11	228054.62
407	180797.77	228027.44

POINT TABLE

POINT	Y	X
408	180844.85	228029.35
409	181072.82	228035.58
410	181072.55	228045.21
411	181333.04	228050.65
412	181359.28	228089.02
413	181378.20	228089.27
414	181557.69	228062.12
415	181742.52	228065.84

POINT TABLE

POINT	Y	X
416	181790.77	228117.26
417	181792.51	227937.26
418	181744.53	227976.12
419	181539.38	227971.76
420	181539.25	227978.77
421	181173.26	227972.29
422	180847.09	227963.39
423	180799.92	227961.47

POINT TABLE

POINT	Y	X
424	180661.75	227924.74
425	180581.83	227921.27
426	180481.49	227926.91
427	180192.68	227914.36
428	180081.63	227909.97

REVISION DATE: 5/19/21
 8/24/21 - N.C.

DATE: 4/2/21
 SCALE, FEET: 0 100 200
 GRID FACTOR: _____

HWY: CTH H
 COUNTY: DUNN

STATE R/W PROJECT NUMBER 7880-07-03
 CONSTRUCTION PROJECT NUMBER 7880-07-73

PLAT SHEET 4.04
 PS&E SHEET _____

PI STA = 128+16.89 PI STA = 143+21.95
 Y = 181975.401 Y = 183480.444
 X = 228021.636 X = 228030.387
 DELTA = 1°13'25" DELTA = 0°42'18"
 D = 0°23'35" D = 0°15'38"
 T = 155.71' T = 135.24'
 L = 311.41' L = 270.48'
 R = 14582.00' R = 21980.00'
 PC STA = 126+61.18 PC STA = 141+86.71
 PT STA = 129+72.58 PT STA = 144+57.19

POINT	POINT	BEARING	DISTANCE
500	501	N51° 21' 57"W	81.95'
501	502	N00° 45' 39"E	130.31'
502	503	N89° 29' 41"W	4.00'
503	504	N00° 21' 13"E	140.20'
504	505	N22° 29' 09"E	75.68'
505	506	N00° 08' 30"E	50.00'
506	507	N24° 57' 31"W	66.26'
507	508	N89° 51' 30"W	66.00'
508	509	S27° 23' 06"W	67.49'
509	510	S00° 08' 30"W	70.00'
510	511	S31° 00' 48"E	58.43'
511	512	S00° 21' 13"W	199.64'
512	513	S05° 30' 42"W	91.75'
513	514	S52° 54' 02"W	48.32'
514	429	S01° 19' 28"W	33.32'
429	431	N89° 50' 07"E	80.18'
431	430	N89° 51' 32"E	99.88'
430	500	N01° 19' 09"E	31.09'

NOTE:
 CTH M R/W ESTABLISHED FROM EXISTING CENTERLINE (WIS STATUTE 82.31) & CSMs ALONG ROADWAY.

EXISTING UTILITY EASEMENT TO BE RELEASED

80 DUNN ENERGY COOPERATIVE
 PARCEL 6: DOC # 382413
 PARCEL 8: DOC # 194269, # 463046
 PARCEL 9: DOC # 194269
 PARCEL 10: DOC # 194270, # 354120, # 400826
 PARCEL 11: DOC # 194271
 PARCEL 12: DOC # 194270, # 354120

81 TELEPHONE USA OF WISCONSIN, LLC (CENTURYLINK)
 PARCEL 6: DOC # 300041, # 464942
 PARCEL 8: DOC # 288705, # 464942
 PARCEL 9: DOC # 288705, # 464942
 PARCEL 10: DOC # 288783, # 464942
 PARCEL 11: DOC # 288779, # 288780, # 464942
 PARCEL 12: DOC # 288783, # 464942

83 NORTHERN STATES POWER COMPANY (XCEL ENERGY)
 PARCEL 10: DOC # 154639, #155841
 PARCEL 11: DOC # 366359, # 363728
 PARCEL 12: DOC # 154639, # 155841, # 365008

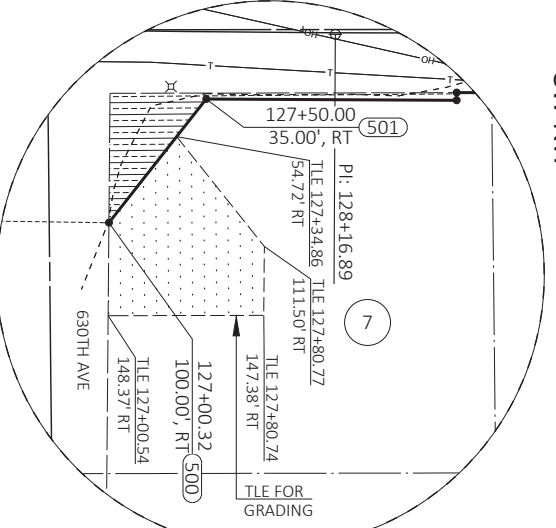
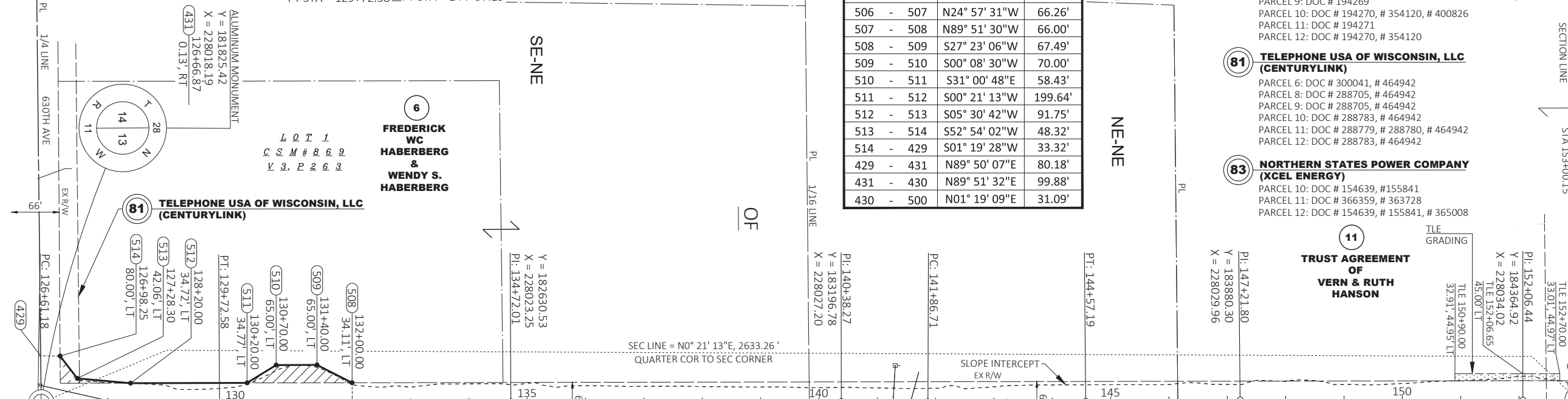

POINT	Y	X
500	181856.75	228118.78
501	181907.92	228054.77
502	182038.22	228056.50
503	182038.25	228052.50
504	182178.45	228053.37
505	182248.38	228082.31
506	182298.38	228082.43
507	182358.45	228054.48

POINT	Y	X
508	182358.61	227988.48
509	182298.68	227957.43
510	182228.69	227957.26
511	182178.61	227987.37
512	181978.98	227986.13
513	181887.65	227977.32
514	181858.50	227938.78

REVISION DATE 5/19/21 8/24/21	DATE : 4/2/21	SCALE, FEET 0 100 200	HWY: CTH H	STATE R/W PROJECT NUMBER 7880-07-03	PLAT SHEET 4.05
	GRID FACTOR		COUNTY: DUNN	CONSTRUCTION PROJECT NUMBER 7880-07-73	PS&E SHEET

POINT TABLE		
POINT	Y	X
600	184658.60	228001.65
601	184658.36	228067.65
602	185016.78	228068.04
603	185063.26	228087.24
604	185250.17	228085.61
605	185299.20	228061.53
606	185508.95	228056.69
607	185509.18	228069.19

POINT TABLE		
POINT	Y	X
608	185619.16	228067.16
609	185619.07	228062.16
610	186016.96	228056.44
611	186016.93	228051.44
612	186418.51	228048.79
613	186418.57	228058.79
614	186542.78	228057.97
615	186713.51	228053.75

POINT TABLE		
POINT	Y	X
616	186879.98	228046.63
617	186879.24	228029.20
618	186876.42	227963.24
619	186709.79	227966.74
620	186709.45	227958.84
621	186542.15	227962.97
622	186542.20	227969.95
623	185857.82	227982.95

POINT TABLE		
POINT	Y	X
624	185743.67	227966.86
625	185163.58	227987.18
626	185062.38	227985.24
627	184988.14	228002.01
628	184838.51	228001.85
629	184805.87	227975.63
630	184708.69	227975.28

PI STA = 157+34.67 Y = 184893.142 X = 228035.953 DELTA = 0°47'12" D = 0°26'59" T = 87.49' L = 174.98' R = 12742.00' PC STA = 156+47.18 PT STA = 158+22.15	PI STA = 159+55.45 Y = 185113.919 X = 228033.727 DELTA = 1°11'00" D = 1°09'31" T = 51.07' L = 102.13' R = 4944.70' PC STA = 159+04.39 PT STA = 160+06.52	PI STA = 161+39.74 Y = 185298.119 X = 228028.064 DELTA = 0°42'24" D = 0°36'41" T = 57.79' L = 115.59' R = 9371.80' PC STA = 160+81.94 PT STA = 161+97.53	PI STA = 167+22.38 Y = 185880.661 X = 228017.343 DELTA = 0°40'32" D = 0°14'54" T = 136.04' L = 272.07' R = 23076.00' PC STA = 165+86.34 PT STA = 168+58.41	PI STA = 174+68.80 Y = 186627.072 X = 228012.408 DELTA = 2°04'13" D = 1°13'26" T = 84.59' L = 169.17' R = 4681.50' PC STA = 173+84.21 PT STA = 175+53.37
--	---	---	---	---

PNT 614 - PNT 615 L = 170.79' LCH = 170.78' CB = N01° 24' 50"W R = 4726.50' Δ = 002° 04' 13"	PNT 620 - PNT 621 L = 167.36' LCH = 167.35' CB = S01° 24' 50"E R = 4631.50' Δ = 002° 04' 13"
---	---

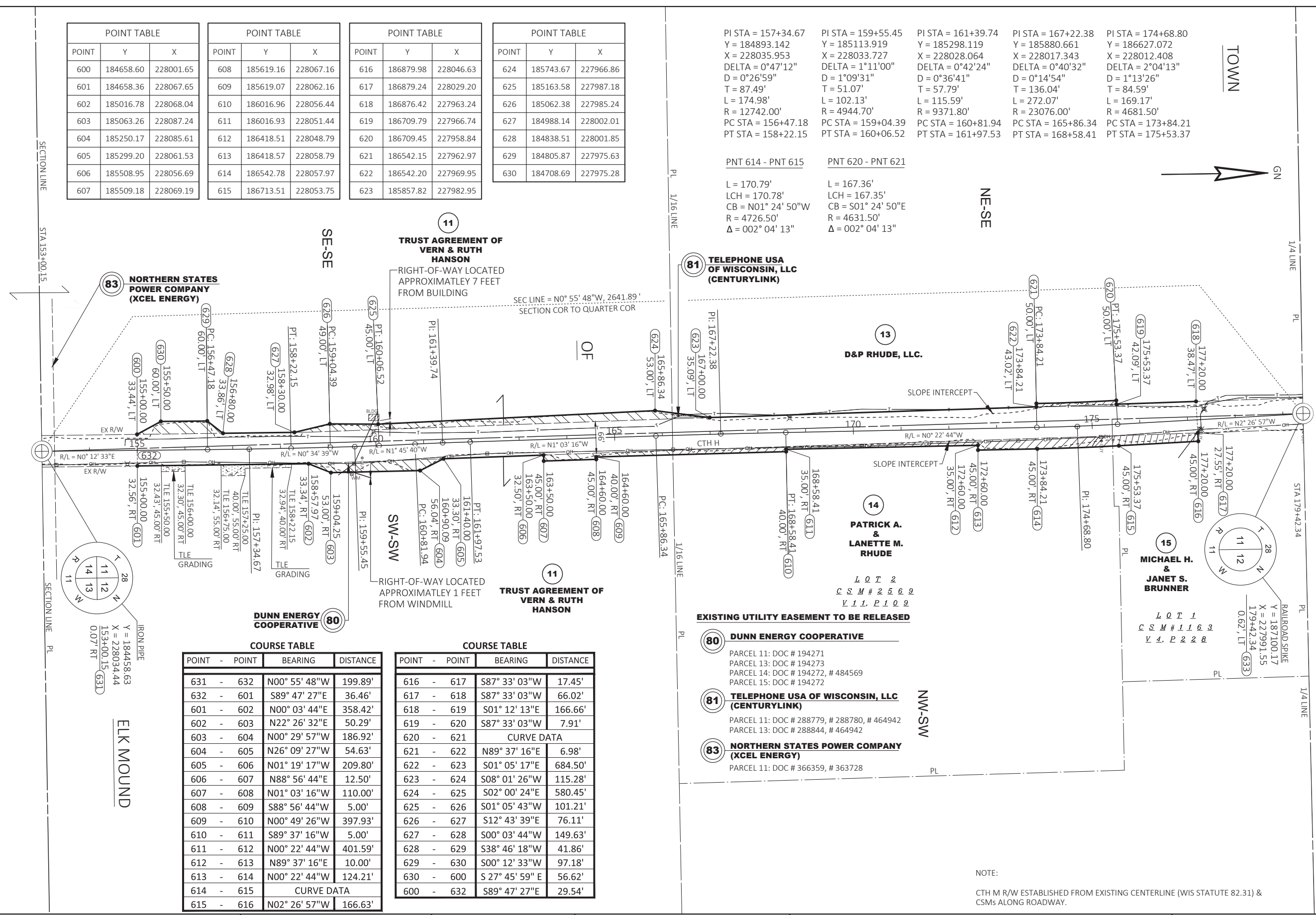

COURSE TABLE			
POINT	POINT	BEARING	DISTANCE
631	632	N00° 55' 48"W	199.89'
632	601	S89° 47' 27"E	36.46'
601	602	N00° 03' 44"E	358.42'
602	603	N22° 26' 32"E	50.29'
603	604	N00° 29' 57"W	186.92'
604	605	N26° 09' 27"W	54.63'
605	606	N01° 19' 17"W	209.80'
606	607	N88° 56' 44"E	12.50'
607	608	N01° 03' 16"W	110.00'
608	609	S88° 56' 44"W	5.00'
609	610	N00° 49' 26"W	397.93'
610	611	S89° 37' 16"W	5.00'
611	612	N00° 22' 44"W	401.59'
612	613	N89° 37' 16"E	10.00'
613	614	N00° 22' 44"W	124.21'
614	615	CURVE DATA	
615	616	N02° 26' 57"W	166.63'

COURSE TABLE			
POINT	POINT	BEARING	DISTANCE
616	617	S87° 33' 03"W	17.45'
617	618	S87° 33' 03"W	66.02'
618	619	S01° 12' 13"E	166.66'
619	620	S87° 33' 03"W	7.91'
620	621	CURVE DATA	
621	622	N89° 37' 16"E	6.98'
622	623	S01° 05' 17"E	684.50'
623	624	S08° 01' 26"W	115.28'
624	625	S02° 00' 24"E	580.45'
625	626	S01° 05' 43"W	101.21'
626	627	S12° 43' 39"E	76.11'
627	628	S00° 03' 44"W	149.63'
628	629	S38° 46' 18"W	41.86'
629	630	S00° 12' 33"W	97.18'
630	600	S 27° 45' 59" E	56.62'
600	632	S89° 47' 27"E	29.54'

- EXISTING UTILITY EASEMENT TO BE RELEASED**
- (80) DUNN ENERGY COOPERATIVE**
PARCEL 11: DOC # 194271
PARCEL 13: DOC # 194273
PARCEL 14: DOC # 194272, # 484569
PARCEL 15: DOC # 194272
 - (81) TELEPHONE USA OF WISCONSIN, LLC (CENTURYLINK)**
PARCEL 11: DOC # 288779, # 288780, # 464942
PARCEL 13: DOC # 288844, # 464942
 - (83) NORTHERN STATES POWER COMPANY (XCEL ENERGY)**
PARCEL 11: DOC # 366359, # 363728

NOTE:
CTH M R/W ESTABLISHED FROM EXISTING CENTERLINE (WIS STATUTE 82.31) & CSMs ALONG ROADWAY.

4

4

REVISION DATE 5/19/21 8/24/21 - N.C.	DATE : 4/2/21	SCALE, FEET 0 100 200	HWY: CTH H	STATE R/W PROJECT NUMBER 7880-07-03	PLAT SHEET 4.06
	GRID FACTOR		COUNTY: DUNN	CONSTRUCTION PROJECT NUMBER 7880-07-73	PS&E SHEET

POINT TABLE		
POINT	Y	X
700	189568.90	227563.69
701	189591.03	227625.90
702	189660.87	227603.41
703	189688.77	227634.80
704	189688.21	227450.97
705	189688.30	227480.42

COURSE TABLE				
POINT	POINT	BEARING	DISTANCE	
700	-	701	N70° 25' 14"E	66.03'
701	-	702	N17° 50' 58"W	73.37'
702	-	703	N48° 21' 44"E	42.00'
703	-	706	N00° 10' 29"W	33.00'
706	-	707	S89° 49' 31"W	183.83'
707	-	704	N00° 10' 29"E	33.00'
704	-	705	N89° 49' 31" E	29.45'
705	-	700	S34° 53' 35"E	145.57'
708	-	706	S89° 49' 31"W	326.51'

PI STA = 186+03.42 Y = 187760.596 X = 227962.221 DELTA = 0°28'31" D = 0°04'36" T = 309.45' L = 618.89' R = 74629.00' PC STA = 182+93.97 PT STA = 189+12.86	PI STA = 192+10.72 Y = 188367.469 X = 227939.377 DELTA = 12°34'27" D = 4°04'12" T = 155.10' L = 308.95' R = 1407.80' PC STA = 190+55.62 PT STA = 193+64.57	PI STA = 196+88.66 Y = 188830.907 X = 227817.539 DELTA = 1°22'40" D = 0°18'58" T = 218.00' L = 435.99' R = 18129.00' PC STA = 194+70.65 PT STA = 199+06.64	PI STA = 203+18.27 Y = 189435.821 X = 227642.851 DELTA = 4°08'37" D = 0°55'19" T = 224.79' L = 449.38' R = 6213.80' PC STA = 200+93.48 PT STA = 205+42.86
---	---	---	--

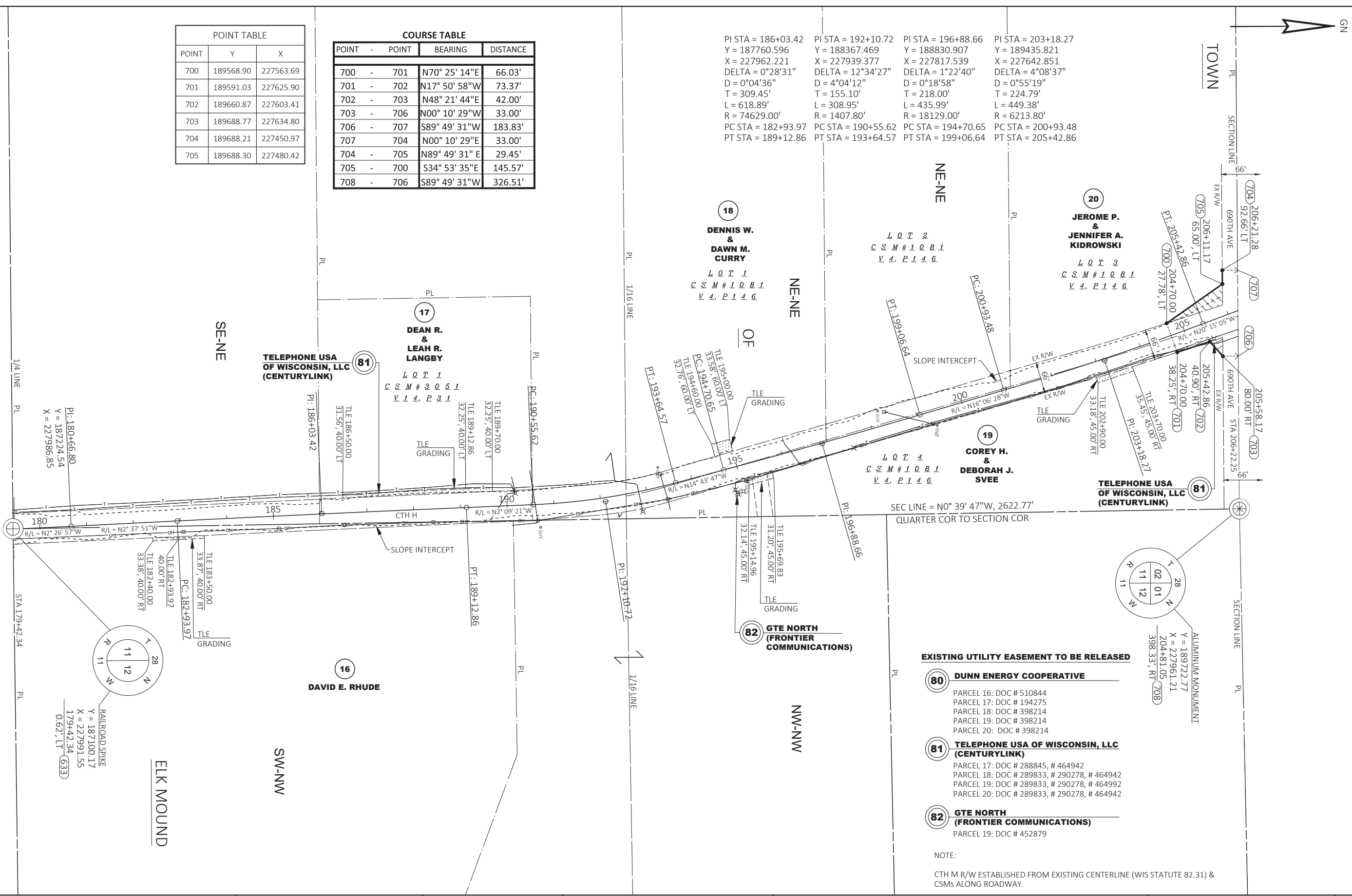

4

4

PL 180+66.80
Y = 187724.54
X = 227986.85

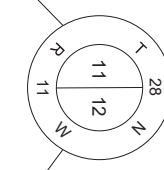

RAILROAD SPIKE
Y = 187100.17
X = 227991.55
179+42.34
0.62', LT (633)

- EXISTING UTILITY EASEMENT TO BE RELEASED**
- 80 DUNN ENERGY COOPERATIVE**
PARCEL 16: DOC # 510844
PARCEL 17: DOC # 194275
PARCEL 18: DOC # 398214
PARCEL 19: DOC # 398214
PARCEL 20: DOC # 398214
 - 81 TELEPHONE USA OF WISCONSIN, LLC (CENTURYLINK)**
PARCEL 17: DOC # 288845, # 464942
PARCEL 18: DOC # 289833, # 290278, # 464942
PARCEL 19: DOC # 289833, # 290278, # 464992
PARCEL 20: DOC # 289833, # 290278, # 464942
 - 82 GTE NORTH (FRONTIER COMMUNICATIONS)**
PARCEL 19: DOC # 452879

NOTE:
CTH M/R/W ESTABLISHED FROM EXISTING CENTERLINE (WIS STATUTE 82.31) & CSMs ALONG ROADWAY.

REVISION DATE 5/19/21 8/24/21 - N.C.	DATE : 4/2/21	SCALE, FEET 0 100 200	HWY: CTH H	STATE R/W PROJECT NUMBER 7880-07-03	PLAT SHEET 4.07
GRID FACTOR			COUNTY: DUNN	CONSTRUCTION PROJECT NUMBER 7880-07-73	PS&E SHEET



EXISTING UTILITY EASEMENT TO BE RELEASED

- 80 DUNN ENERGY COOPERATIVE**
PARCEL 22: DOC # 517119
- 81 TELEPHONE USA OF WISCONSIN, LLC (CENTURYLINK)**
PARCEL 22: DOC # 289833, # 290278, # 464942
- 82 GTE NORTH (FRONTIER COMMUNICATIONS)**
PARCEL 22: DOC # 351548

PI STA = 208+94.26 Y = 189976.391 X = 227443.410 DELTA = 32°06'38" D = 13°58'28" T = 117.99' L = 229.78' R = 410.00' PC STA = 207+76.27 PT STA = 210+06.04	PI STA = 211+18.72 Y = 190202.135 X = 227490.814 DELTA = 8°03'23" D = 3°34'52" T = 112.67' L = 224.98' R = 1600.00' PC STA = 210+06.04 PT STA = 212+31.02	PI STA = 213+50.35 Y = 190420.264 X = 227569.842 DELTA = 26°05'29" D = 11°07'31" T = 119.33' L = 234.52' R = 515.00' PC STA = 212+31.02 PT STA = 214+65.54	PI STA = 218+31.42 Y = 190757.277 X = 227918.913 DELTA = 46°27'04" D = 15°12'21" T = 161.70' L = 305.48' R = 376.80' PC STA = 216+69.72 PT STA = 219+75.21	PI STA = 227+07.42 Y = 191651.156 X = 227911.981 DELTA = 0°38'40" D = 0°21'25" T = 90.24' L = 180.47' R = 16047.00' PC STA = 216+69.72 PT STA = 227+97.65	PI STA = 231+92.29 Y = 192136.032 X = 227913.673 DELTA = 1°25'40" D = 1°29'32" T = 47.84' L = 95.67' R = 3839.40' PC STA = 226+17.18 PT STA = 231+44.46
---	--	---	---	--	--

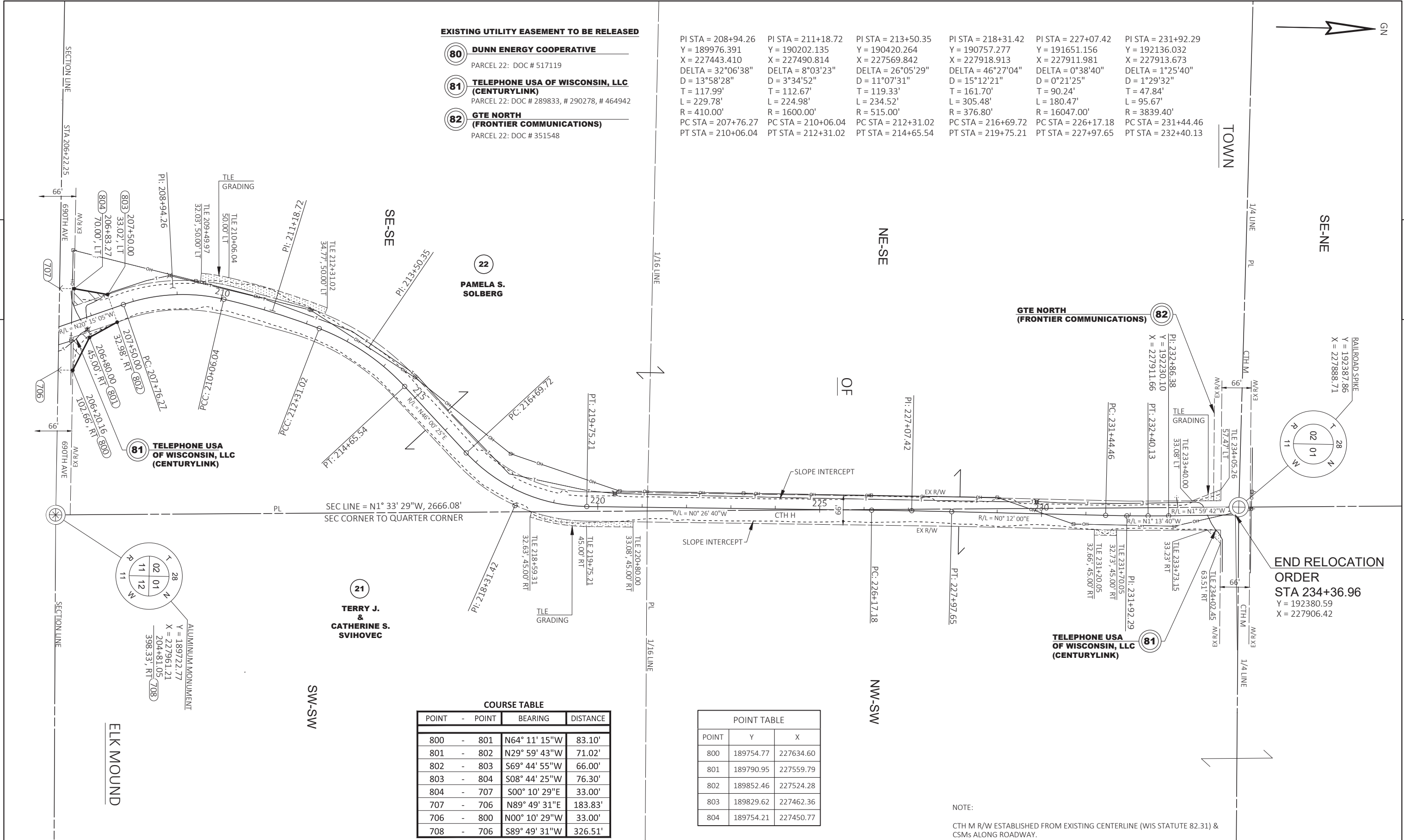

81 TELEPHONE USA OF WISCONSIN, LLC (CENTURYLINK)

82 GTE NORTH (FRONTIER COMMUNICATIONS)

END RELOCATION ORDER
STA 234+36.96
Y = 192380.59
X = 227906.42

ALUMINUM MONUMENT
Y = 189722.77
X = 227961.21
204+81.05
398.33', RT (708)

21 TERRY J. & CATHERINE S. SVIHOVEC

22 PAMELA S. SOLBERG

COURSE TABLE

POINT	- POINT	BEARING	DISTANCE
800	- 801	N64° 11' 15"W	83.10'
801	- 802	N29° 59' 43"W	71.02'
802	- 803	S69° 44' 55"W	66.00'
803	- 804	S08° 44' 25"W	76.30'
804	- 707	S00° 10' 29"E	33.00'
707	- 706	N89° 49' 31"E	183.83'
706	- 800	N00° 10' 29"W	33.00'
708	- 706	S89° 49' 31"W	326.51'

POINT TABLE

POINT	Y	X
800	189754.77	227634.60
801	189790.95	227559.79
802	189852.46	227524.28
803	189829.62	227462.36
804	189754.21	227450.77

NOTE:
CTH M R/W ESTABLISHED FROM EXISTING CENTERLINE (WIS STATUTE 82.31) & CSMs ALONG ROADWAY.

REVISION DATE 5/19/21 8/24/21 - N.C.	DATE : 4/2/21	SCALE, FEET 0 100 200	HWY: CTH H	STATE R/W PROJECT NUMBER 7880-07-03	PLAT SHEET 4.08
	GRID FACTOR		COUNTY: DUNN	CONSTRUCTION PROJECT NUMBER 7880-07-73	PS&E SHEET

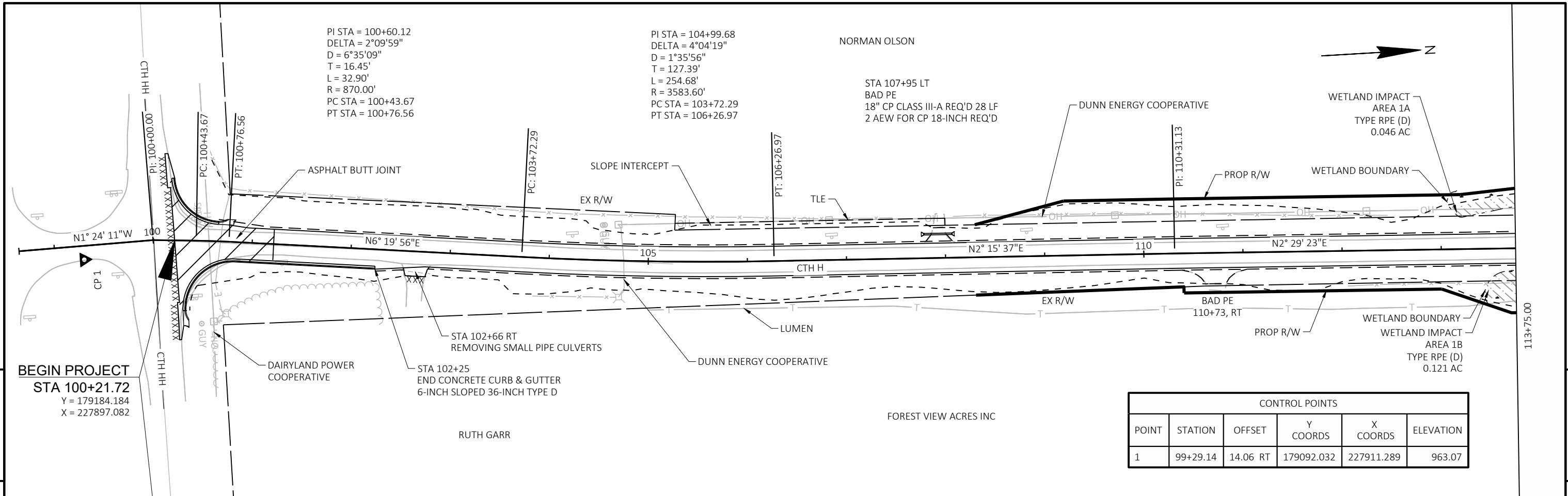

BEGIN PROJECT
STA 100+21.72
 Y = 179184.184
 X = 227897.082

CONTROL POINTS					
POINT	STATION	OFFSET	Y COORDS	X COORDS	ELEVATION
1	99+29.14	14.06 RT	179092.032	227911.289	963.07

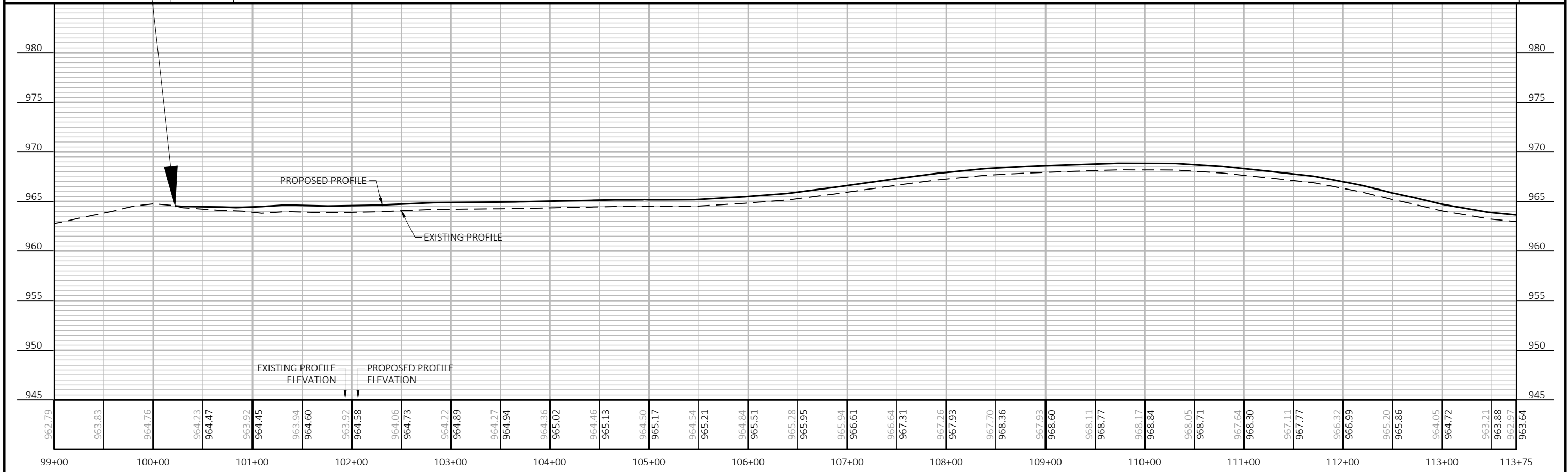

PROJECT NO: 7880-07-73	HWY: CTH H	COUNTY: DUNN	PLAN AND PROFILE: CTH H	SHEET	E
------------------------	------------	--------------	-------------------------	-------	----------

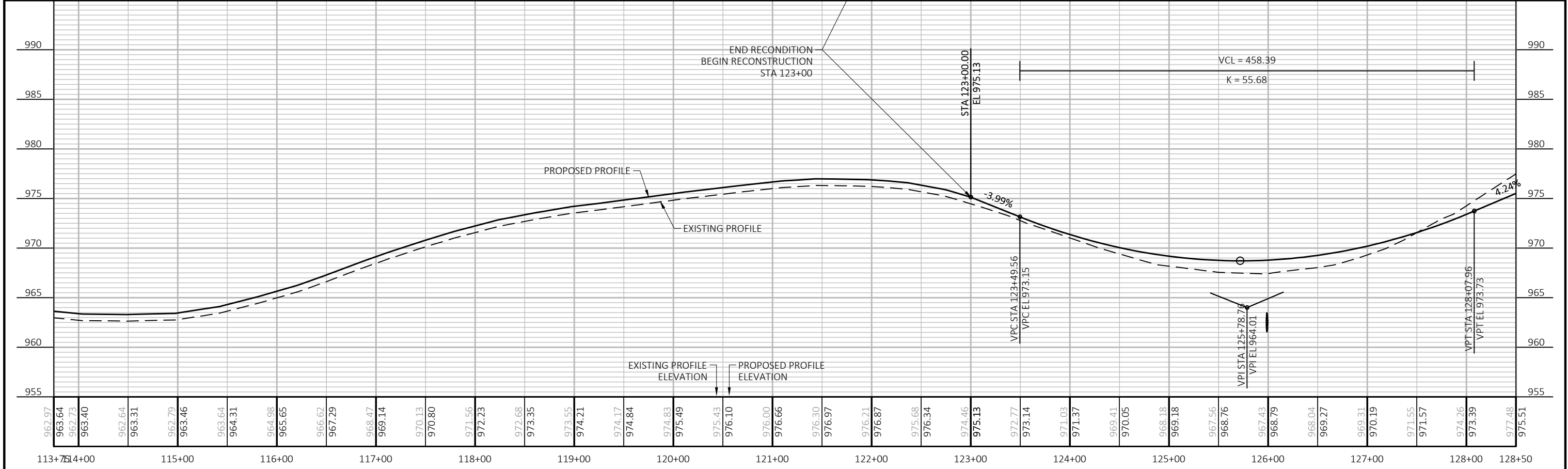
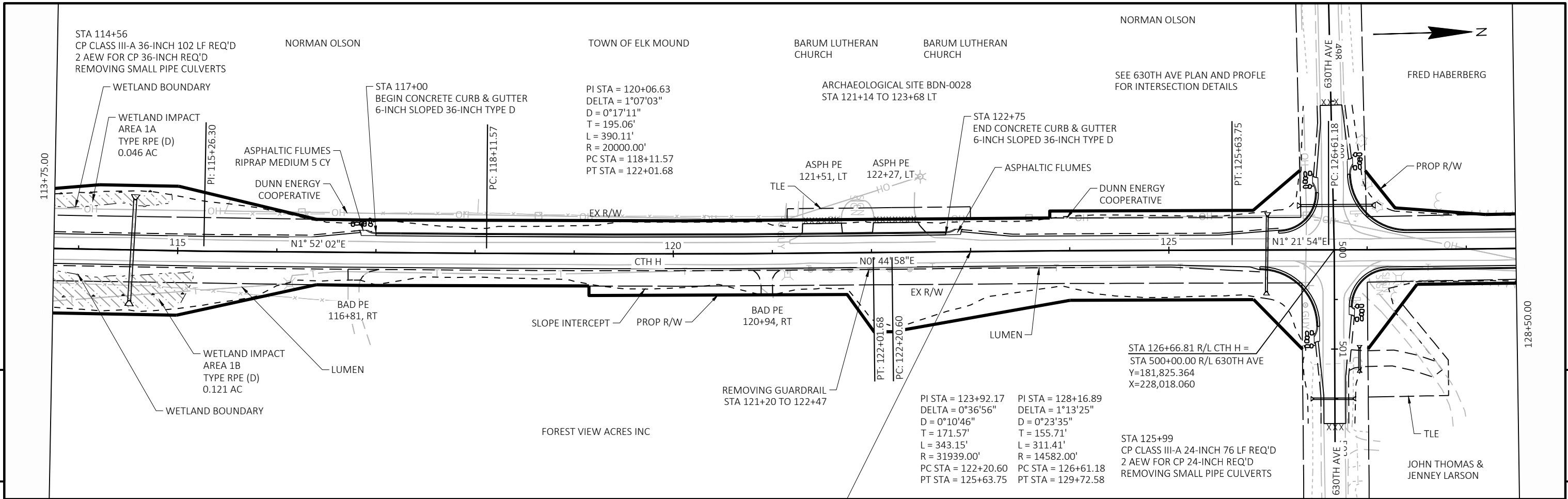

PROJECT NO: 7880-07-73	HWY: CTH H	COUNTY: DUNN	PLAN AND PROFILE: CTH H	SHEET 5
------------------------	------------	--------------	-------------------------	---------

PI STA = 128+16.89
 DELTA = 1°13'25"
 D = 0°23'35"
 T = 155.71'
 L = 311.41'
 R = 14582.00'
 PC STA = 126+61.18
 PT STA = 129+72.58

FRED HABERBERG

FREDERICK & WENDY HABERBERG

ROY KISTNER

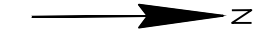

STA 142+25 LT
 BAD PE
 18" CP CLASS III-A REQ'D 24 LF
 2 AEW FOR CP 18-INCH REQ'D

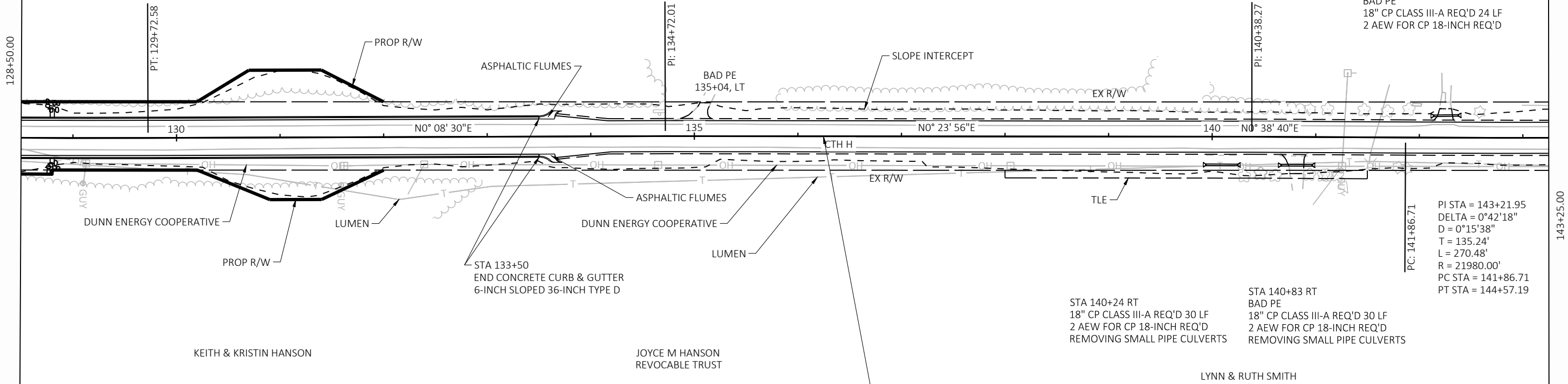

5

5

KEITH & KRISTIN HANSON

JOYCE M HANSON
 REVOCABLE TRUST

LYNN & RUTH SMITH

STA 140+24 RT
 18" CP CLASS III-A REQ'D 30 LF
 2 AEW FOR CP 18-INCH REQ'D
 REMOVING SMALL PIPE CULVERTS

STA 140+83 RT
 BAD PE
 18" CP CLASS III-A REQ'D 30 LF
 2 AEW FOR CP 18-INCH REQ'D
 REMOVING SMALL PIPE CULVERTS

PI STA = 143+21.95
 DELTA = 0°42'18"
 D = 0°15'38"
 T = 135.24'
 L = 270.48'
 R = 21980.00'
 PC STA = 141+86.71
 PT STA = 144+57.19

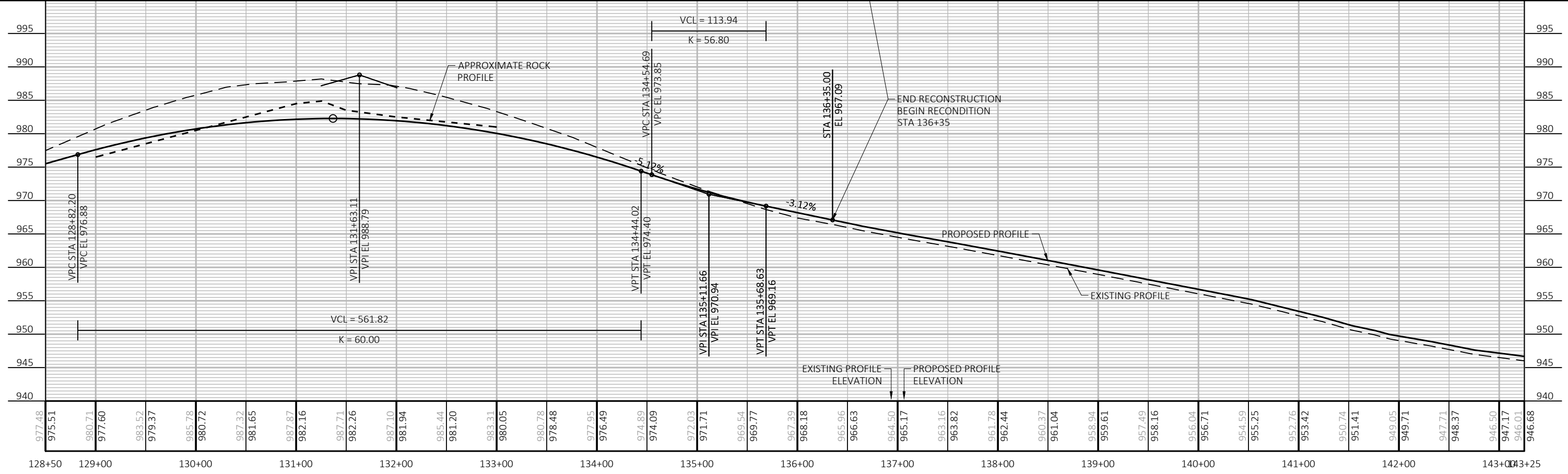

PROJECT NO: 7880-07-73	HWY: CTH H	COUNTY: DUNN	PLAN AND PROFILE: CTH H	SHEET	E
------------------------	------------	--------------	-------------------------	-------	---

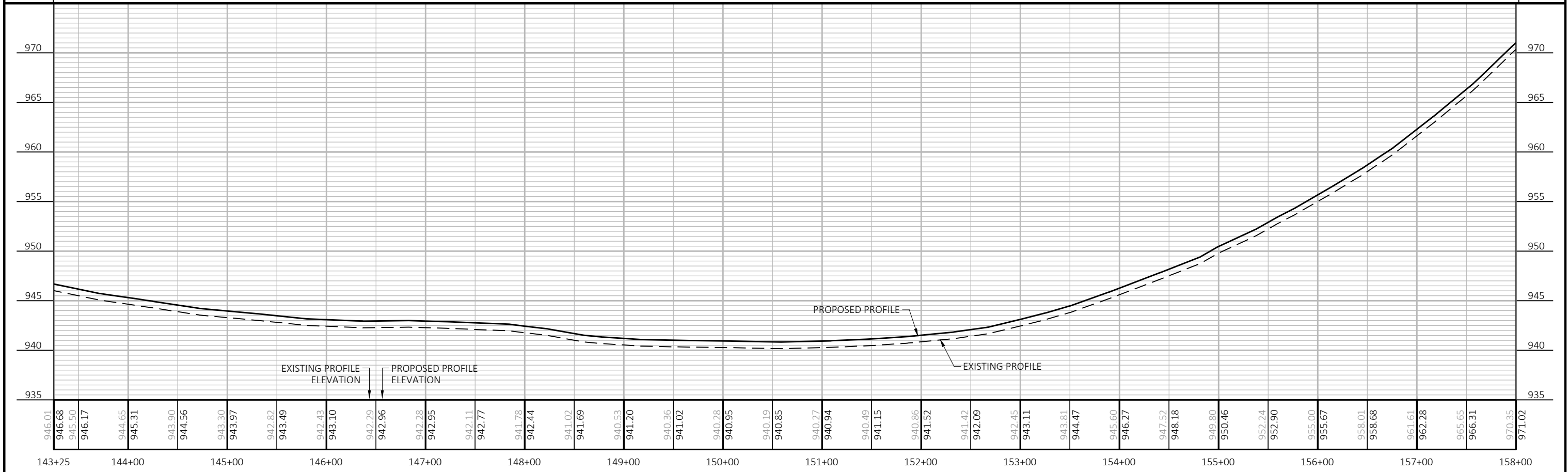
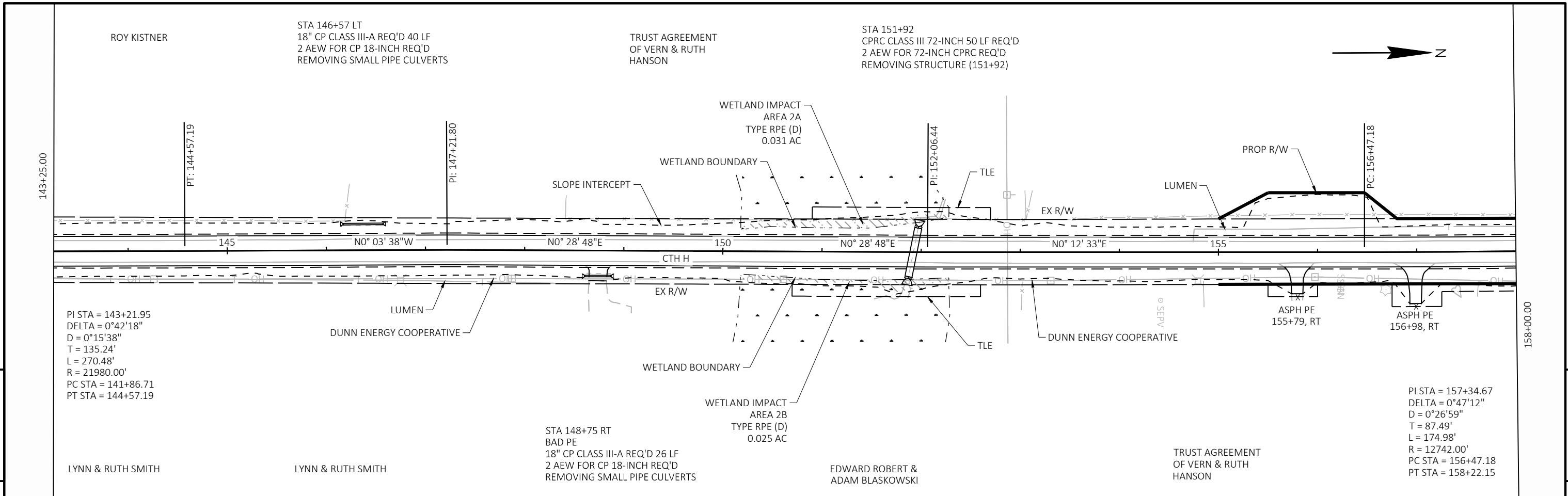

PROJECT NO: 7880-07-73	HWY: CTH H	COUNTY: DUNN	PLAN AND PROFILE: CTH H	SHEET	E
------------------------	------------	--------------	-------------------------	-------	---

CONTROL POINTS					
POINT	STATION	OFFSET	Y COORDS	X COORDS	ELEVATION
3	160+39.28	19.24 RT	185198.302	228050.382	984.39

TRUST AGREEMENT
OF VERN & RUTH
HANSON

STA 167+81
CP CLASS III-A 36-INCH 50 LF REQ'D
2 AEW FOR CP 36-INCH REQ'D
REMOVING SMALL PIPE CULVERTS

D & P RHUDE, LLC

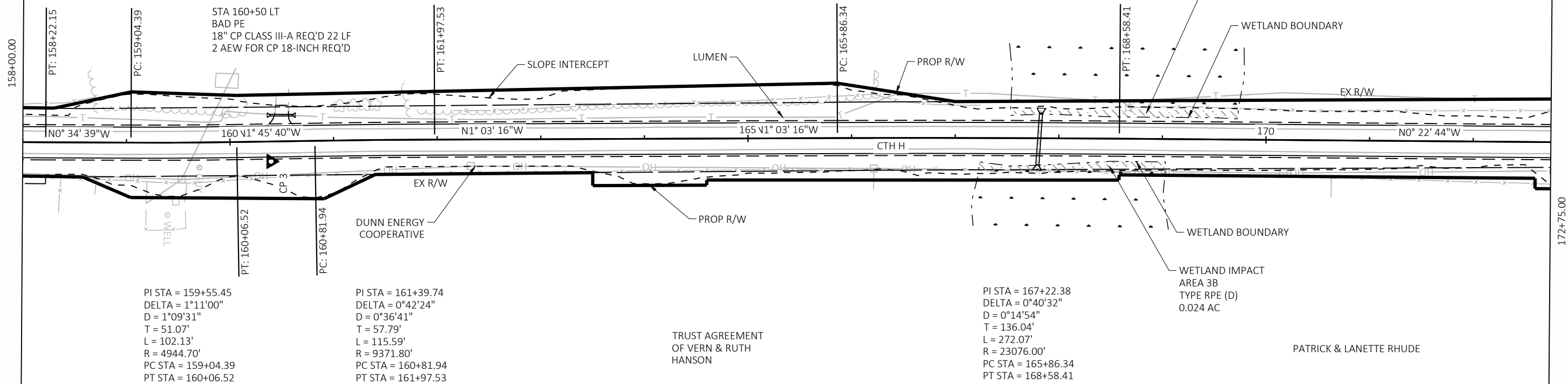

5

5

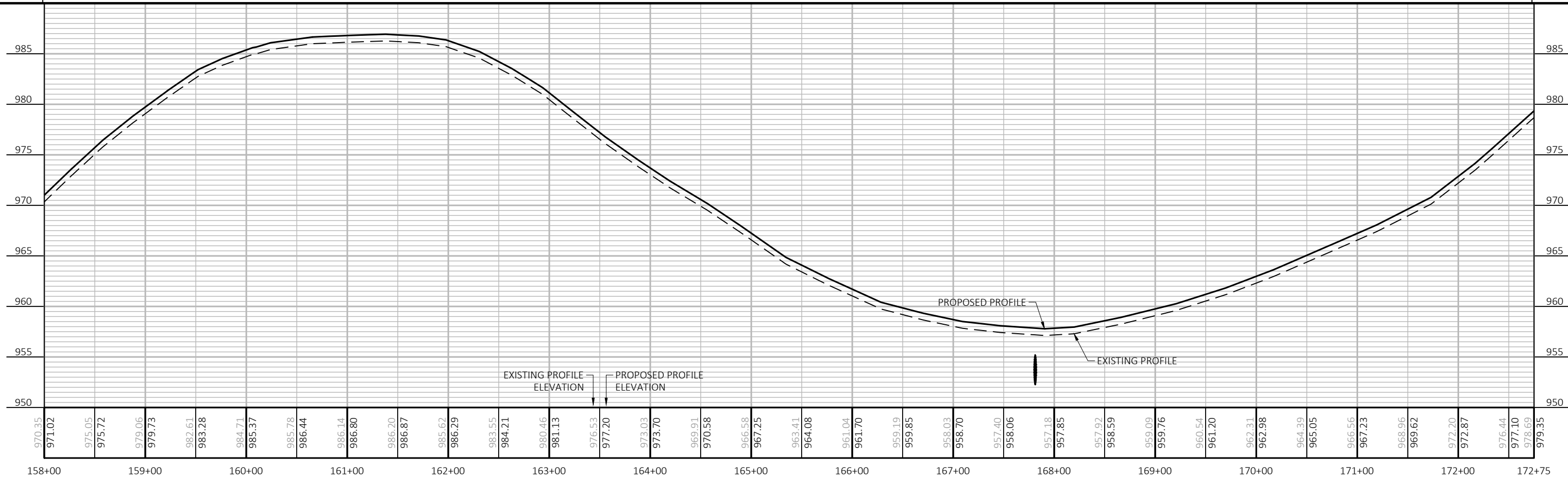

PROJECT NO: 7880-07-73 HWY: CTH H COUNTY: DUNN PLAN AND PROFILE: CTH H SHEET: E

CONTROL POINTS					
POINT	STATION	OFFSET	Y COORDS	X COORDS	ELEVATION
4	184+72.97	9.84 LT	187629.868	227958.595	1010.54

STA 177+55 LT
BAD PE
18" CP CLASS III-A REQ'D 28 LF
2 AEW FOR CP 18-INCH REQ'D
REMOVING SMALL PIPE CULVERTS

D & P RHUDE, LLC

STA 181+66
CP CLASS III-A 24-INCH 42 LF REQ'D
2 AEW FOR CP 24-INCH REQ'D
REMOVING SMALL PIPE CULVERTS



DEAN & LEAH LANGBY

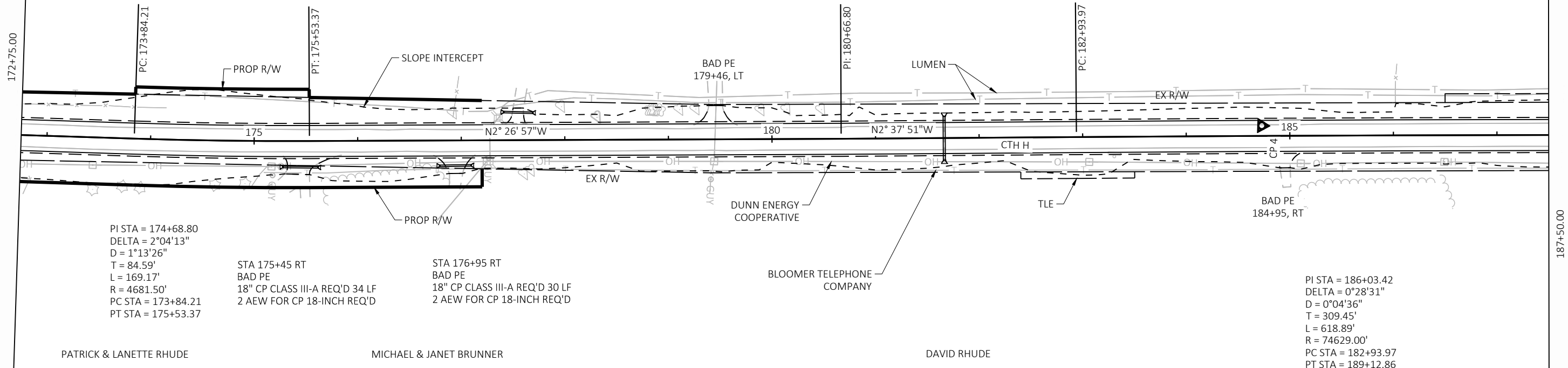

PI STA = 174+68.80
DELTA = 2°04'13"
D = 1°13'26"
T = 84.59'
L = 169.17'
R = 4681.50'
PC STA = 173+84.21
PT STA = 175+53.37

STA 175+45 RT
BAD PE
18" CP CLASS III-A REQ'D 34 LF
2 AEW FOR CP 18-INCH REQ'D

STA 176+95 RT
BAD PE
18" CP CLASS III-A REQ'D 30 LF
2 AEW FOR CP 18-INCH REQ'D

PI STA = 186+03.42
DELTA = 0°28'31"
D = 0°04'36"
T = 309.45'
L = 618.89'
R = 74629.00'
PC STA = 182+93.97
PT STA = 189+12.86

PATRICK & LANETTE RHUDE

MICHAEL & JANET BRUNNER

DAVID RHUDE

5

5

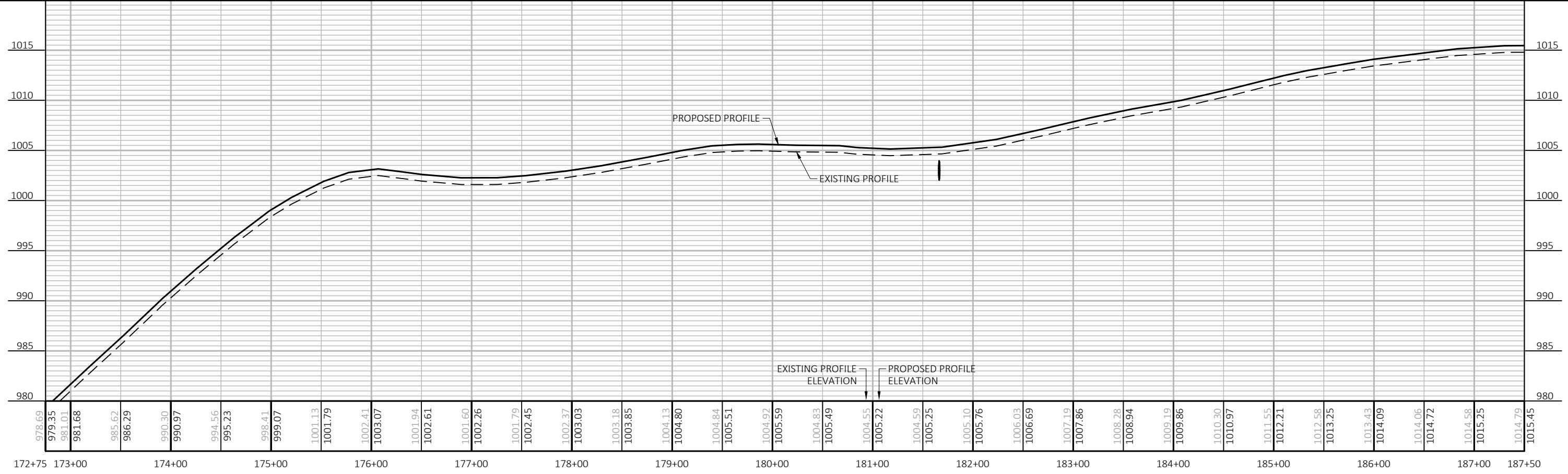

PROJECT NO: 7880-07-73	HWY: CTH H	COUNTY: DUNN	PLAN AND PROFILE: CTH H	SHEET	E
------------------------	------------	--------------	-------------------------	-------	---

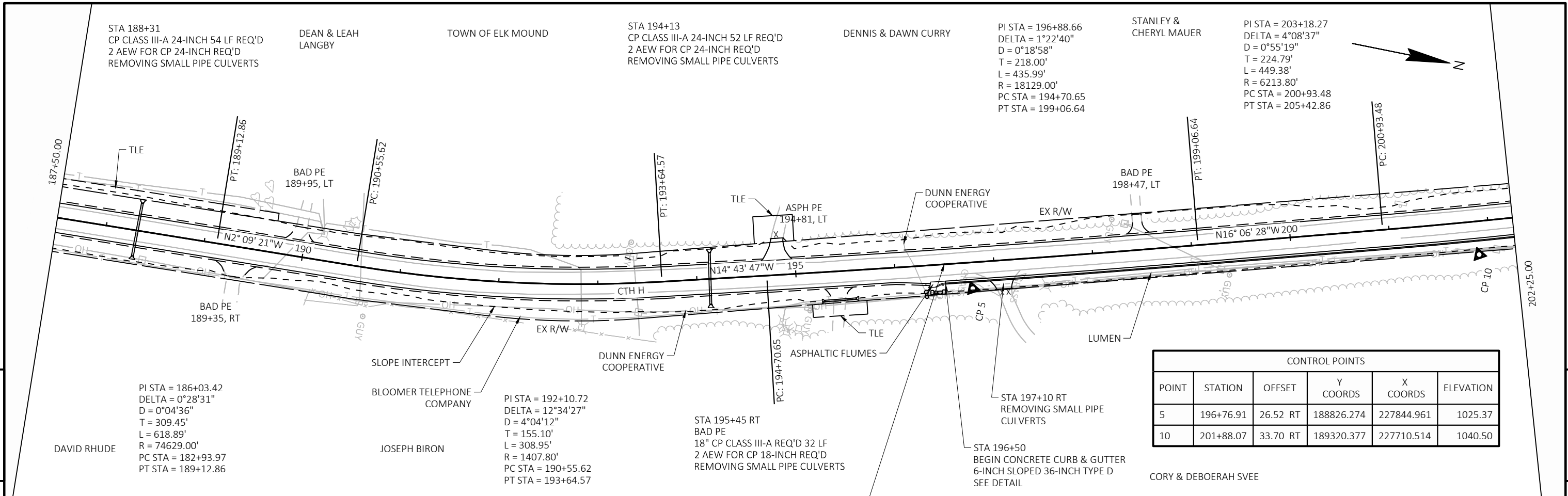

CONTROL POINTS					
POINT	STATION	OFFSET	Y COORDS	X COORDS	ELEVATION
5	196+76.91	26.52 RT	188826.274	227844.961	1025.37
10	201+88.07	33.70 RT	189320.377	227710.514	1040.50

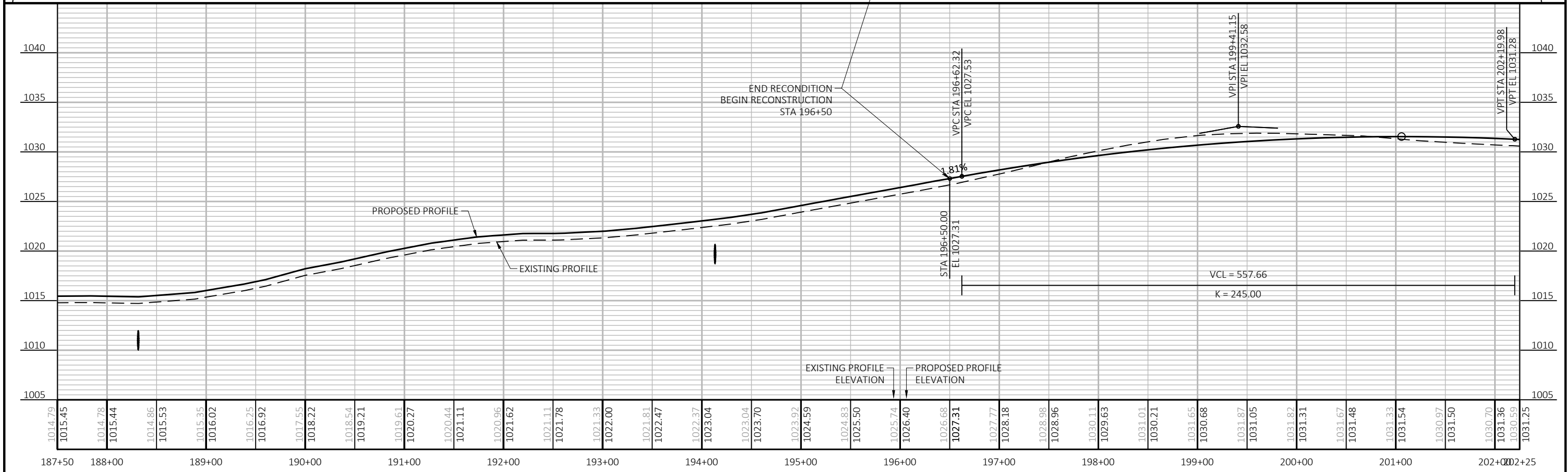

PROJECT NO: 7880-07-73	HWY: CTH H	COUNTY: DUNN	PLAN AND PROFILE: CTH H	SHEET	E
------------------------	------------	--------------	-------------------------	-------	----------

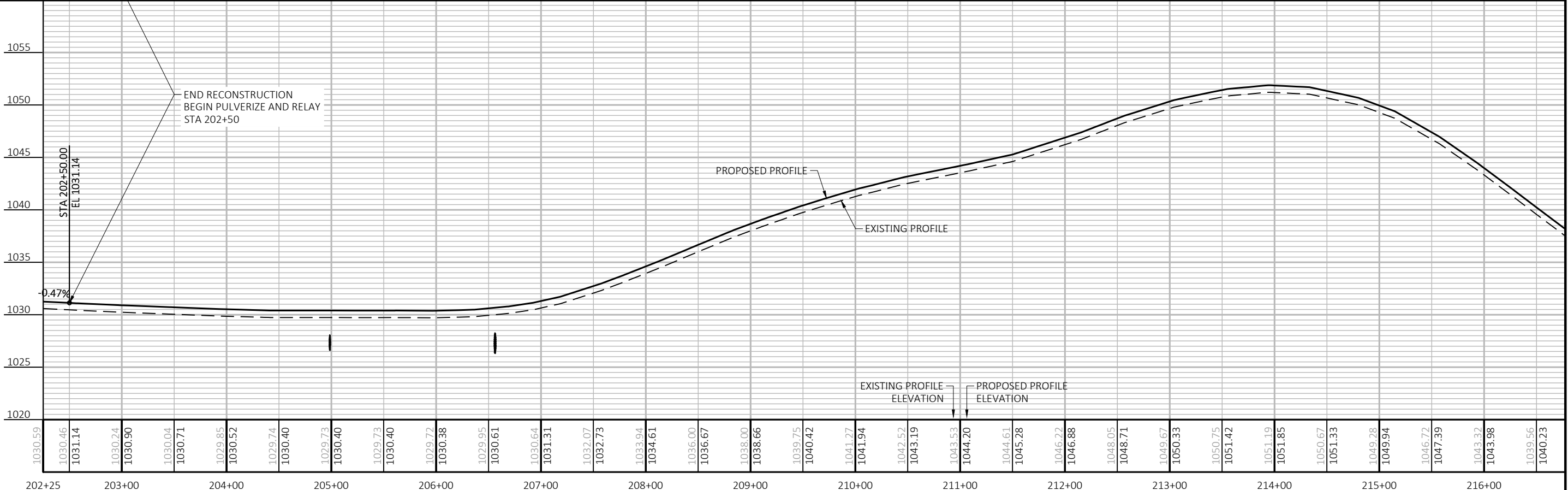
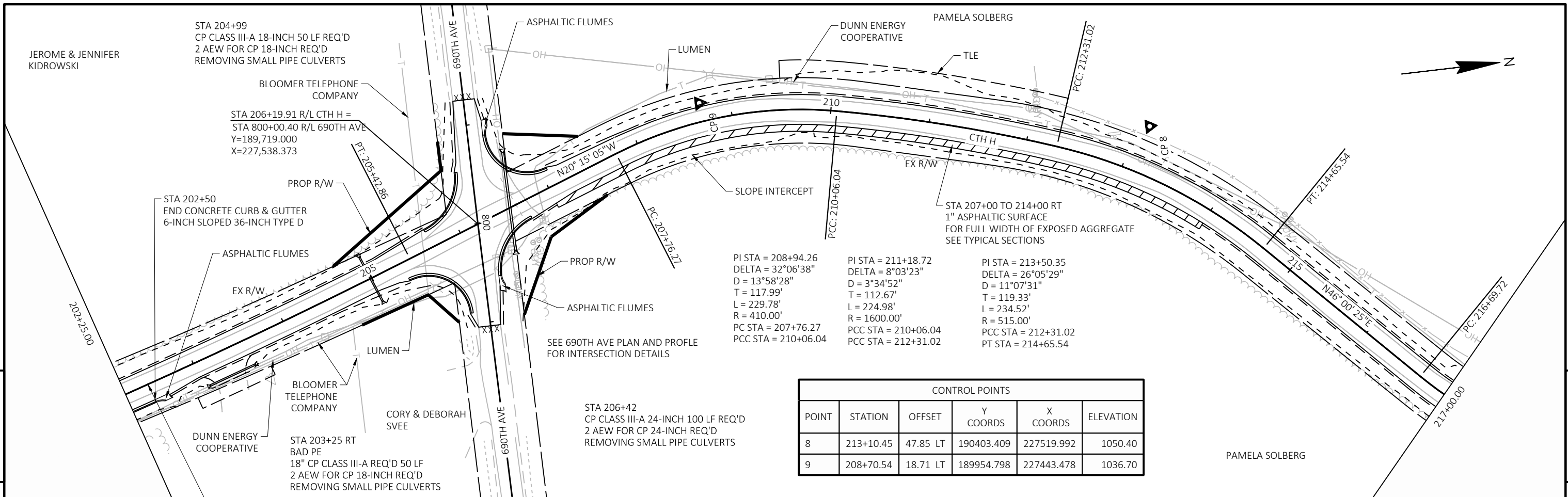

PROJECT NO: 7880-07-73	HWY: CTH H	COUNTY: DUNN	PLAN AND PROFILE: CTH H	SHEET	E
------------------------	------------	--------------	-------------------------	-------	---

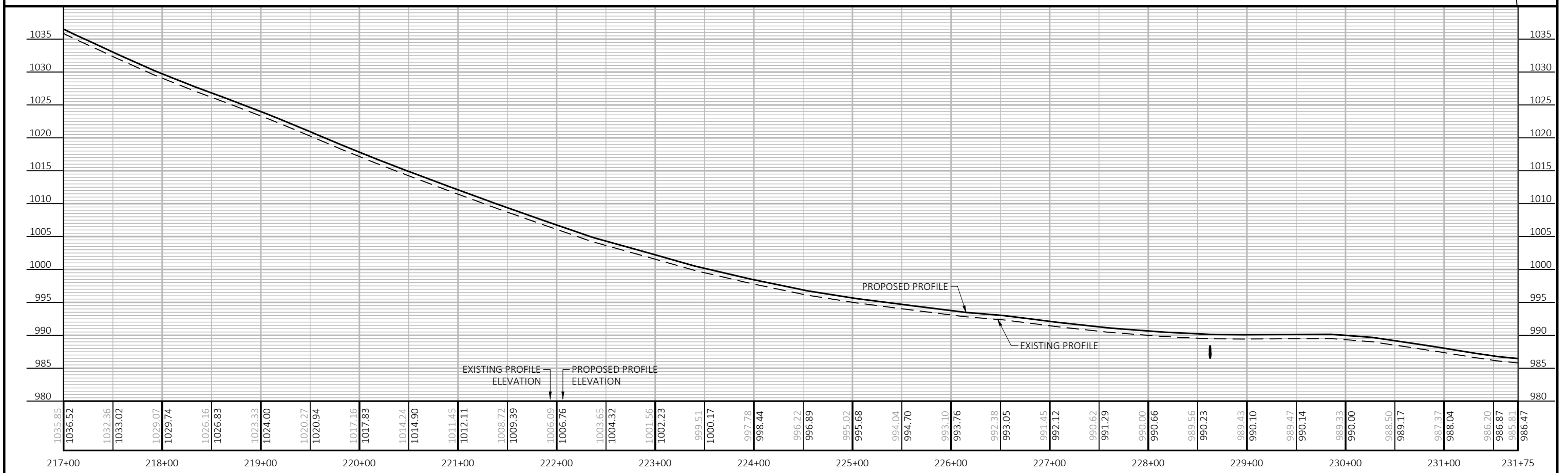
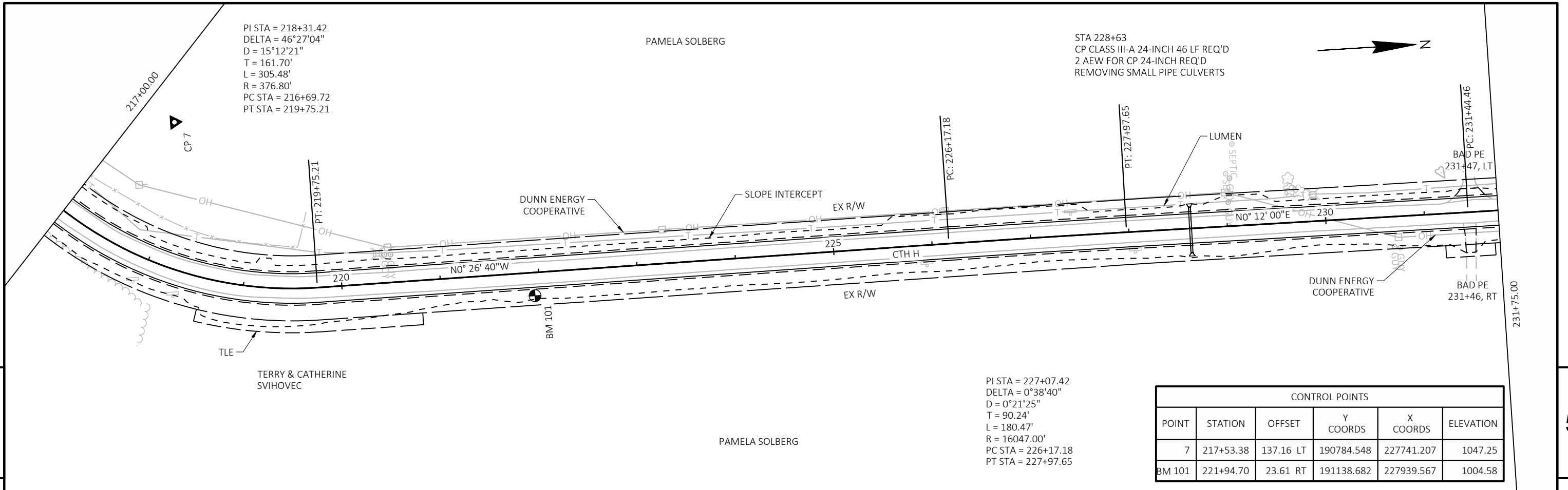

PROJECT NO: 7880-07-73	HWY: CTH H	COUNTY: DUNN	PLAN AND PROFILE: CTH H	SHEET	E
------------------------	------------	--------------	-------------------------	-------	----------

5

5

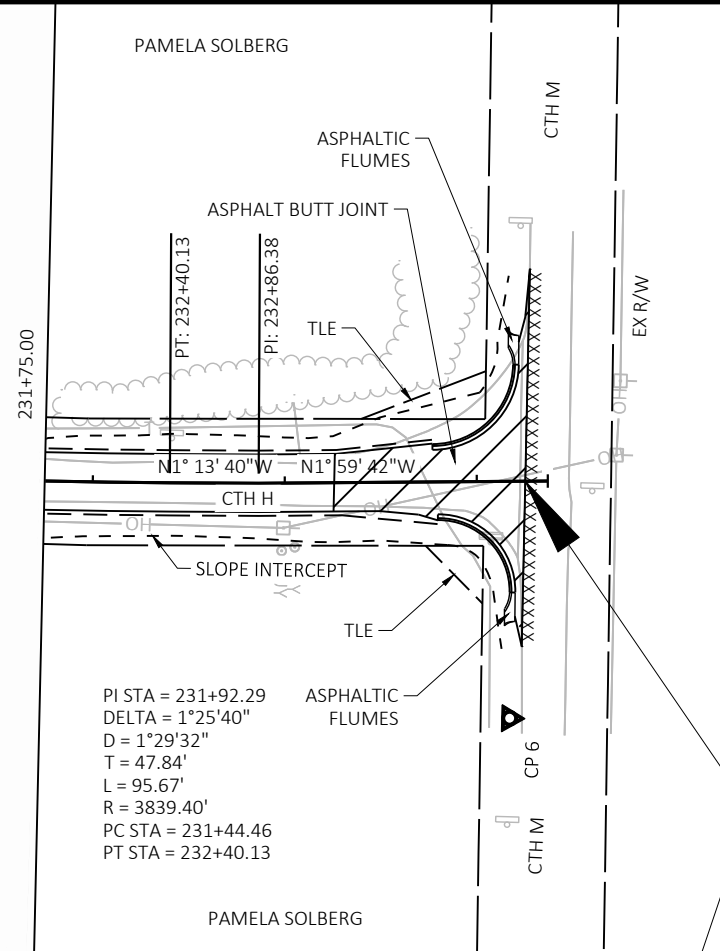

PI STA = 231+92.29
 DELTA = 1°25'40"
 D = 1°29'32"
 T = 47.84'
 L = 95.67'
 R = 3839.40'
 PC STA = 231+44.46
 PT STA = 232+40.13

END PROJECT
 STA 234+25.27

CONTROL POINTS					
POINT	STATION	OFFSET	Y COORDS	X COORDS	ELEVATION
6			192364.038	228030.486	976.25

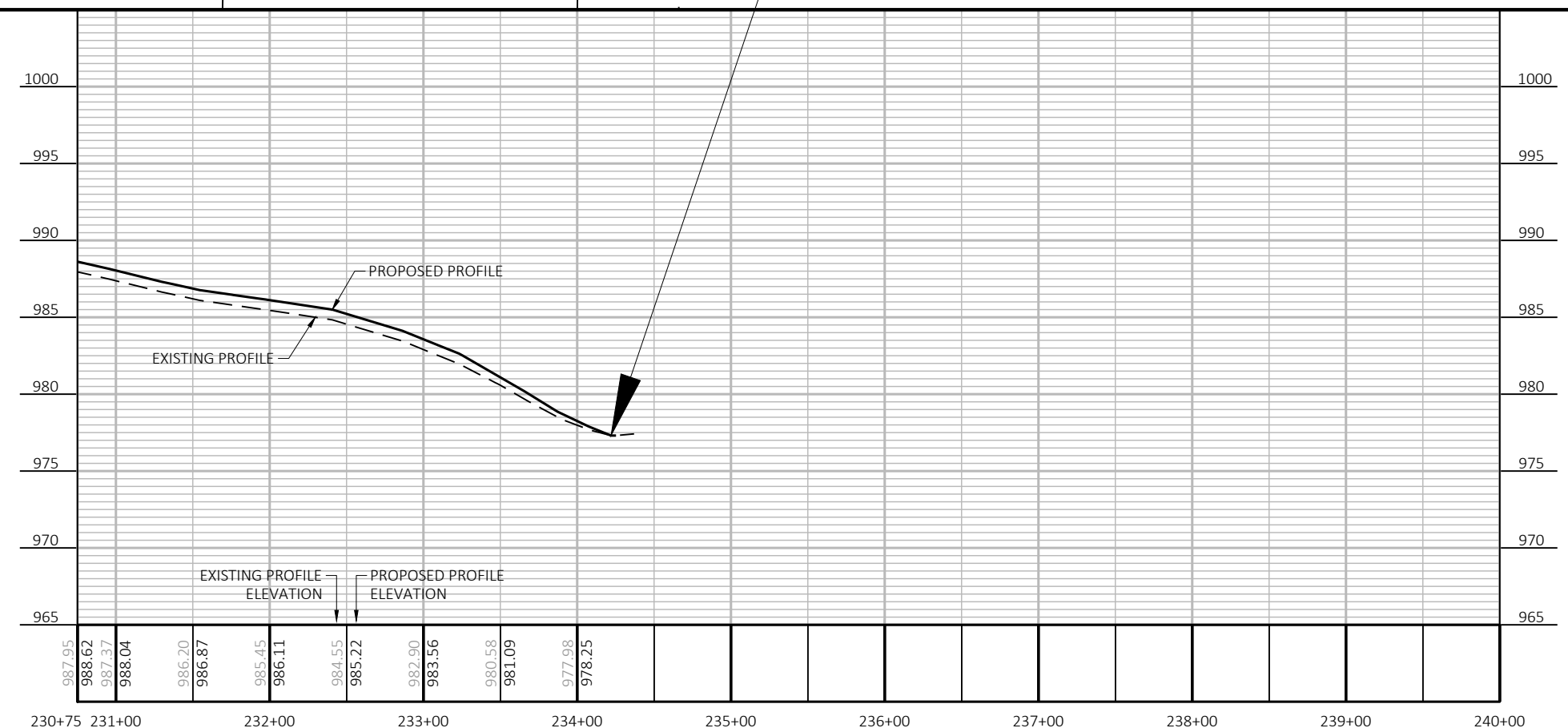

PROJECT NO: 7880-07-73 HWY: CTH H COUNTY: DUNN PLAN AND PROFILE: CTH H SHEET **E**

630TH AVE					
POINT NUMBER	STATION	OFFSET	ELEVATION	NORTHING	EASTING
1 RP	127+40.67	77.21' LT	--	181900.63	227942.41
2	126+80.37	76.19' LT	968.11	181840.63	227942.20
3	126+98.46	34.41' LT	969.52	181857.74	227984.37
4	127+40.67	17.21' LT	970.44	181899.52	228002.40
5	127+21.30	17.32' RT	969.88	181879.51	228036.56
6	126+93.31	29.10' RT	968.91	181851.23	228047.75
7	126+81.72	57.21' RT	967.44	181838.99	228075.60
8 RP	127+21.57	57.32' RT	--	181878.98	228076.55
9	126+50.63	57.78' LT	967.61	181810.57	227959.92
10	126+39.20	28.96' LT	968.32	181798.45	227988.45
11	126+10.61	16.96' LT	968.53	181769.59	227999.76
12 RP	126+10.64	56.96' LT	--	181770.57	227959.77
13	125+91.80	17.00' RT	967.91	181749.98	228033.27
14	126+34.23	34.57' RT	967.63	181791.97	228051.85
15	126+51.80	77.00' RT	966.84	181808.53	228094.68
16 RP	125+91.68	77.13' RT	--	181748.42	228093.38

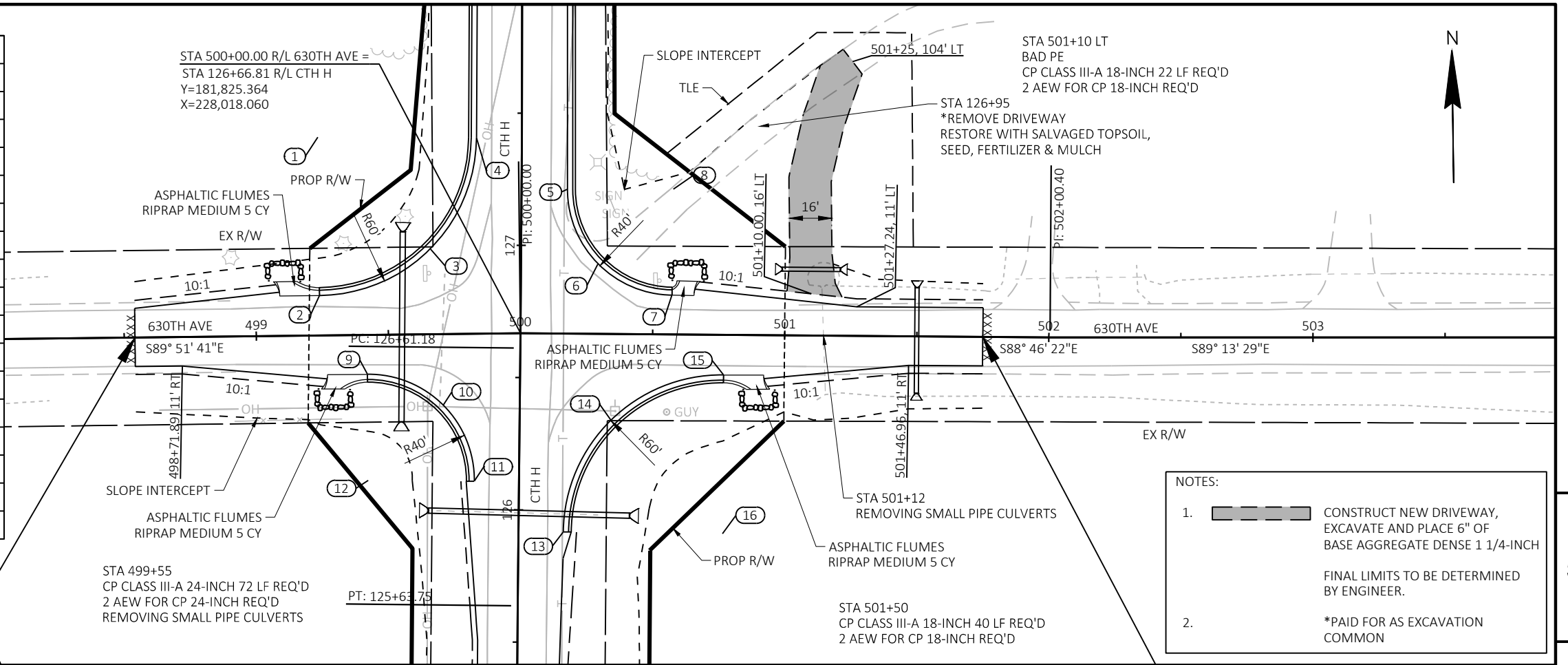

- NOTES:
-  CONSTRUCT NEW DRIVEWAY, EXCAVATE AND PLACE 6" OF BASE AGGREGATE DENSE 1 1/4-INCH

FINAL LIMITS TO BE DETERMINED BY ENGINEER.
 -  *PAID FOR AS EXCAVATION COMMON

BEGIN CONSTRUCTION
STA 498+54
SAWCUT REQ'D

END CONSTRUCTION
STA 501+75
SAWCUT REQ'D

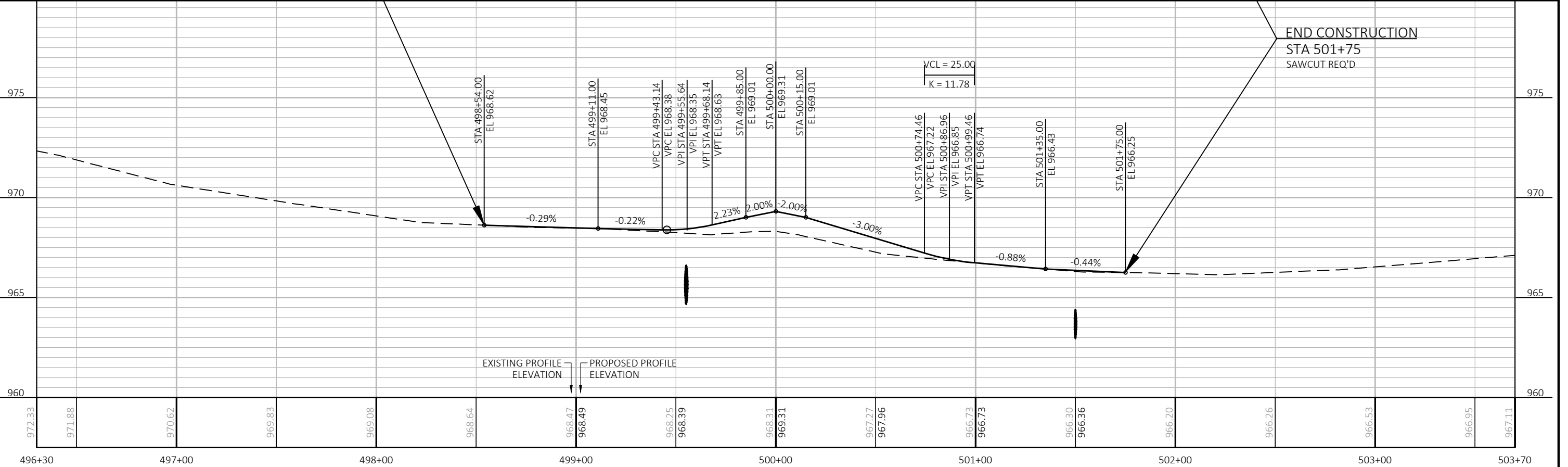

690TH AVE					
POINT NUMBER	STATION	OFFSET	ELEVATION	NORTHING	EASTING
50 RP	207+07.02	62.00' LT	--	189779.27	227450.05
52	206+64.85	77.70' LT	1026.27	189734.27	227449.92
53	206+66.00	43.50' LT	1028.93	189747.18	227481.61
54	206+82.61	24.20' LT	1031.08	189769.45	227493.97
55	207+07.02	17.00' LT	1031.19	189794.84	227492.27
56	206+71.28	17.00' RT	1030.47	189773.08	227536.54
57	206+37.05	27.73' RT	1030.29	189744.68	227558.45
58	206+15.05	56.07' RT	1030.10	189733.85	227592.66
59 RP	206+71.28	77.00' RT	--	189793.85	227592.83
60 RP	205+68.58	77.06' LT	--	189644.17	227483.85
61	206+24.81	56.13' LT	1028.14	189704.17	227484.02
62	206+02.78	27.76' LT	1029.08	189693.32	227518.26
63	205+68.50	17.06' LT	1030.03	189664.86	227540.16
64	205+32.84	17.01' RT	1029.56	189643.18	227584.47
65	205+69.77	36.32' RT	1030.63	189684.54	227589.81
66	205+74.99	77.70' RT	1030.70	189703.75	227626.82
67 RP	205+32.92	62.01' RT	--	189658.75	227626.69

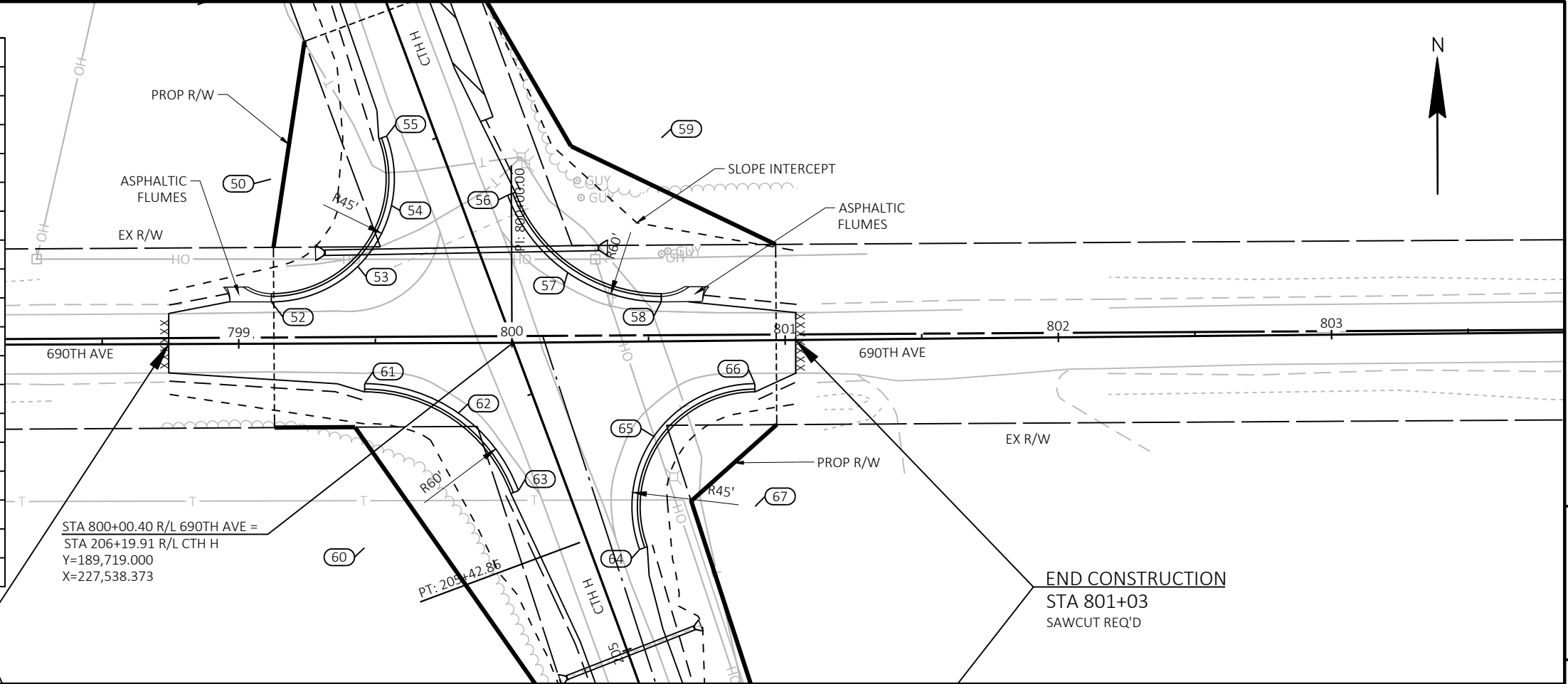

BEGIN CONSTRUCTION
STA 798+74
SAWCUT REQ'D

END CONSTRUCTION
STA 801+03
SAWCUT REQ'D

STA 800+00.40 R/L 690TH AVE =
STA 206+19.91 R/L CTH H
Y=189,719.000
X=227,538.373

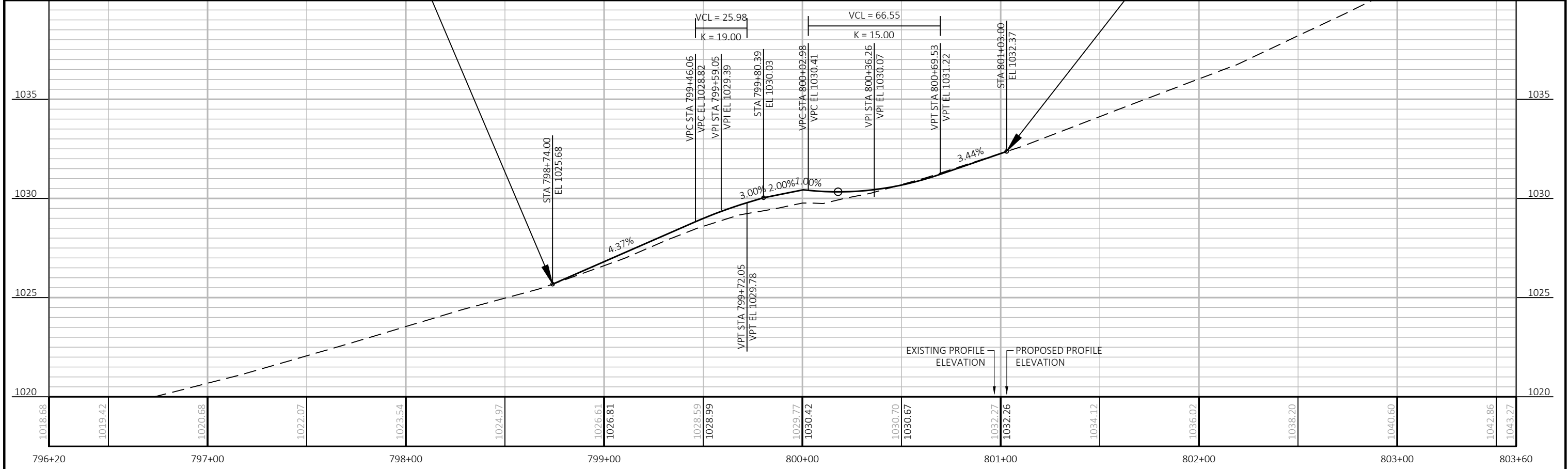

PROJECT NO: 7880-07-73	HWY: CTH H	COUNTY: DUNN	PLAN AND PROFILE: 690TH AVE	SHEET E
------------------------	------------	--------------	-----------------------------	---------

Standard Detail Drawing List

08D01-22A	CONCRETE CURB & GUTTER
08D01-22B	CONCRETE CURB, TIES AND CURB AND GUTTER APPLICATIONS
08D04-06	CONCRETE SURFACE DRAINS & ASPHALTIC FLUMES
08E08-03	TYPICAL INSTALLATIONS OF EROSION BALES / TEMPORARY DITCH CHECKS
08E09-06	SILT FENCE
08E15-01	CULVERT PIPE CHECK
08F01-11	APRON ENDWALLS FOR CULVERT PIPE
08F03-03	DETAILS FOR PIPE CATTLE PASS, CONCRETE ENDWALLS AND STEPS
08F04-08	JOINT TIES FOR CONCRETE PIPE AND CONCRETE COLLAR DETAIL
08F07-05	STEEL APRON ENDWALLS FOR CULVERT PIPE AND PIPE ARCH SLOPED SIDE DRAINS
08F08-02	STEEL APRON ENDWALLS FOR CULVERT PIPE AND PIPE ARCH SLOPED CROSS DRAINS
08F10-01	CONCRETE MASONRY ENDWALLS FOR CULVERT PIPE AND PIPE ARCH
09A01-13A	AT-GRADE SIDE ROAD INTERSECTION, TYPES "B1", "B2", "C" AND D AND TEE INTERSECTION BYPASS LANE
15A03-02A	FLEXIBLE MARKER POST FOR CULVERT END
15A03-02B	FLEXIBLE MARKER POST FOR CULVERT END
15C02-08A	BARRICADES AND SIGNS FOR MAINLINE CLOSURES
15C02-08B	BARRICADES AND SIGNS FOR VARIOUS CLOSURES
15C02-08C	DETOUR SIGNING FOR MAINLINE CLOSURES
15C03-05	BARRICADES AND SIGNS FOR SIDEROAD CLOSURES
15C08-20A	LONGITUDINAL MARKING (MAINLINE)

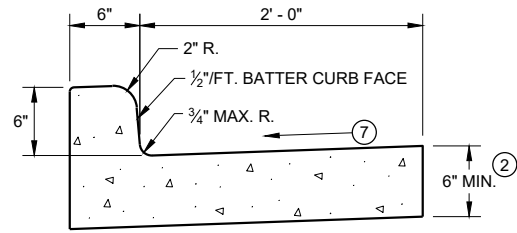

TYPES A^① & D

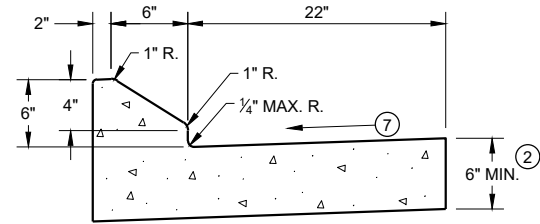

6" SLOPED CURB TYPES G^① & J

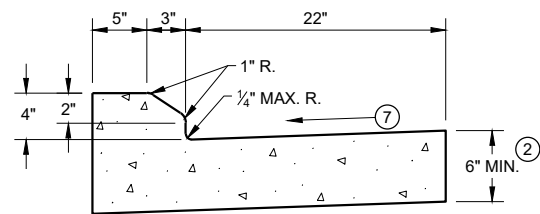

4" SLOPED CURB TYPES G^① & J

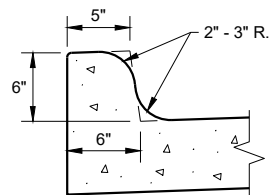

TYPES K^① & L
(OPTIONAL CURB SHAPE)

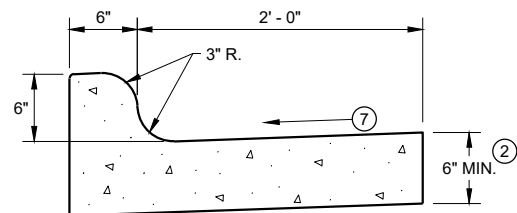

TYPES K^① & L

CONCRETE CURB AND GUTTER 30"

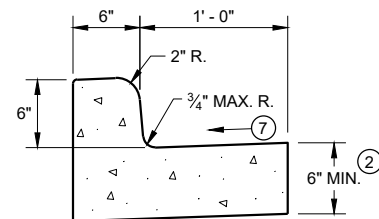

TYPES A^① & D

CONCRETE CURB AND GUTTER 18"

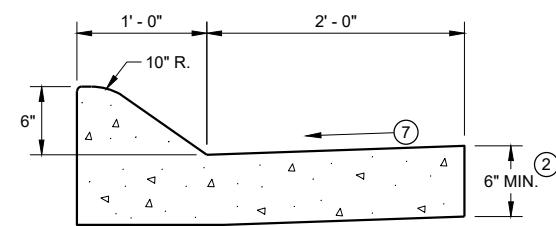

6" SLOPED CURB TYPES A^① & D

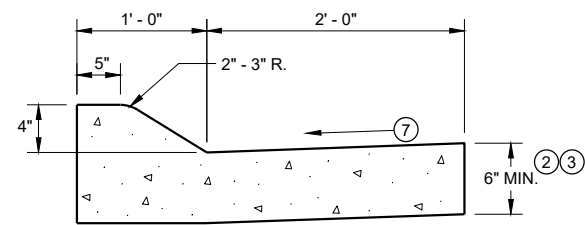

4" SLOPED CURB TYPES A^① & D

CONCRETE CURB AND GUTTER 36"

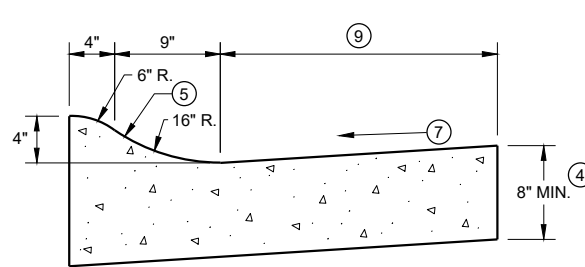

4" SLOPED CURB TYPES R^① & T

TBT & TBTT	X
30"	22"
36"	28"

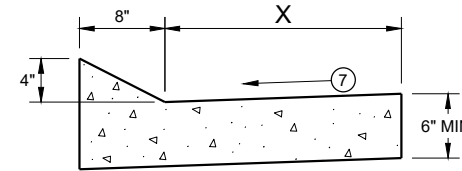

TYPES TBT & TBTT^①

CONCRETE CURB AND GUTTER

PAVEMENT THICKNESS AND MAXIMUM CONCRETE PANEL WIDTH TABLE

PAVEMENT THICKNESS	MAXIMUM PANEL WIDTH
LESS THAN 10"	12'
10" & ABOVE	15'

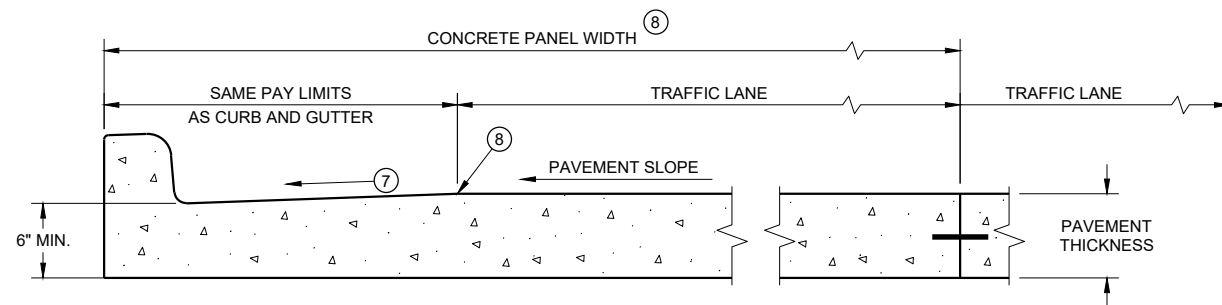

PARTIAL SECTION OF PAVEMENT *
WITH INTEGRAL CURB AND GUTTER

* BIKE LANE IS NOT SHOWN

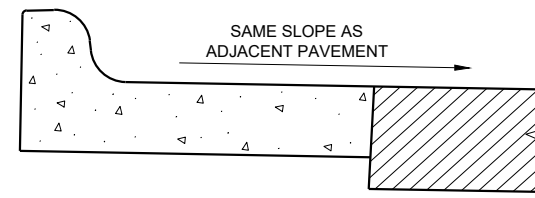

REVERSE SLOPE GUTTER^⑥
(TYPICAL FOR ALL CURB & GUTTER TYPES)

GENERAL NOTES

DETAILS OF CONSTRUCTION AND WORKMANSHIP NOT SHOWN ON THIS DRAWING SHALL CONFORM TO THE PERTINENT REQUIREMENTS OF THE CONTRACT.

PAVEMENT TIES AND TIE BARS SHALL BE EPOXY COATED IN CONFORMANCE WITH SUBSECTION 505.2.6.2 OF THE STANDARD SPECIFICATIONS.

INTEGRAL CURB AND GUTTER SHALL CONFORM TO THE DETAILS SHOWN FOR CONCRETE CURB AND GUTTER INCLUDING THE TRANSVERSE GUTTER SLOPE.

UNLESS OTHERWISE SHOWN ON THE TYPICAL CROSS SECTIONS, THE BASE AGGREGATE AND COMMON EXCAVATION LIMITS ARE 2' - 0" BEHIND THE BACK OF CURBS.

- ① TIE BARS ARE REQUIRED FOR CURB AND GUTTERS TYPES A, G, K, R, AND TBTT.
- ② THE BOTTOM OF CURB AND GUTTER MAY BE CONSTRUCTED EITHER LEVEL OR PARALLEL TO THE SLOPE OF THE SUBGRADE OR BASE AGGREGATE PROVIDED A 6" MINIMUM GUTTER THICKNESS IS MAINTAINED.
- ③ USE 8" MINIMUM GUTTER THICKNESS WHEN USED WITH AN ADJACENT CONCRETE TRUCK APRON PLACED BEHIND BACK OF CURB.
- ④ THE BOTTOM OF CURB AND GUTTER MAY BE CONSTRUCTED EITHER LEVEL OR PARALLEL TO THE SLOPE OF THE SUBGRADE OR BASE AGGREGATE PROVIDED A 8" MINIMUM GUTTER THICKNESS IS MAINTAINED.
- ⑤ UNLESS OTHERWISE NOTED, FOR STAKING PURPOSES THE FACE OF CURB IS 6" FROM THE BACK OF CURB.
- ⑥ WHEN REVERSE SLOPE GUTTER IS REQUIRED, THE LOCATION(S) WILL BE SHOWN ELSEWHERE IN THE PLAN.
- ⑦ USE 4% GUTTER CROSS SLOPE UNLESS OTHERWISE NOTED IN THE PLANS.
- ⑧ INCLUDE LONGITUDINAL JOINT AND TIE BARS ALONG LANE EDGE WHEN CONCRETE PANEL WIDTH EXCEEDS THE MAXIMUM WIDTH PER TABLE BELOW. LONGITUDINAL JOINT(S) ARE NOT ALLOWED WITHIN TRAFFIC LANES AND BIKE LANES. LONGITUDINAL JOINT MAY BE SAWED.
- ⑨ CONCRETE CURB AND GUTTER 4-INCH SLOPED 30-INCH TYPE "R" AND "T" = 17 INCHES
CONCRETE CURB AND GUTTER 4-INCH SLOPED 36-INCH TYPE "R" AND "T" = 23 INCHES

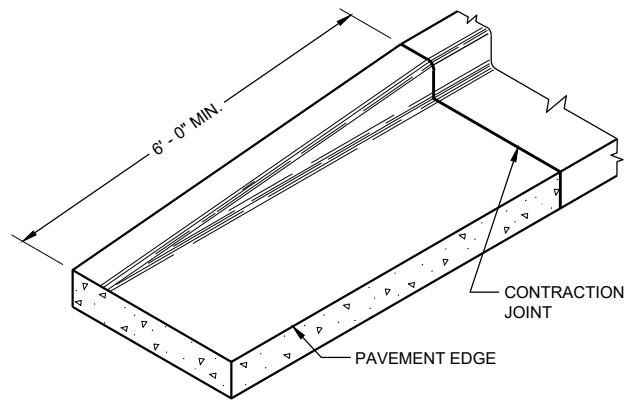

END SECTION CURB AND GUTTER

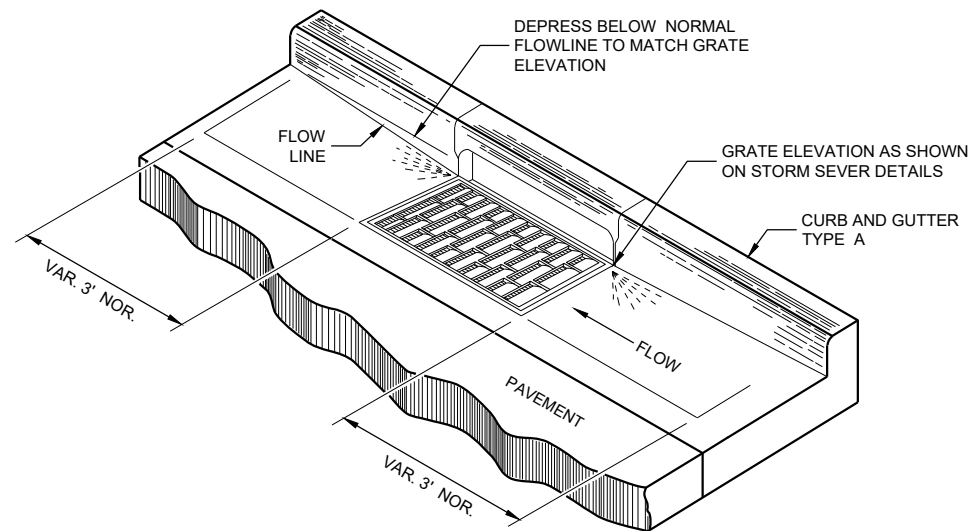

DETAIL OF CURB AND GUTTER AT INLETS
(TYPICAL H INLET COVER SHOWN)

GENERAL NOTES

DETAILS OF CONSTRUCTION AND WORKMANSHIP NOT SHOWN ON THIS DRAWING SHALL CONFORM TO THE PERTINENT REQUIREMENTS OF THE CONTRACT.

PAVEMENT TIES AND TIE BARS SHALL BE EPOXY COATED IN CONFORMANCE WITH SUBSECTION 505.2.6.2 OF THE STANDARD SPECIFICATIONS.

UNLESS OTHERWISE SHOWN ON THE TYPICAL CROSS SECTIONS, THE BASE AGGREGATE AND COMMON EXCAVATION LIMITS ARE 2' - 0" BEHIND THE BACK OF CURBS.

- ① TIE BARS ARE REQUIRED FOR CURB AND GUTTERS TYPES A, G, K, R, AND TBTT.
- ② THE BOTTOM OF CURB AND GUTTER MAY BE CONSTRUCTED EITHER LEVEL OR PARALLEL TO THE SLOPE OF THE SUBGRADE OR BASE AGGREGATE PROVIDED A 6" MINIMUM GUTTER THICKNESS IS MAINTAINED.
- ⑨ REFER TO SDD 08D18 AND 08D19 FOR ADDITIONAL DRIVEWAY ENTRANCE CURB DETAILS.

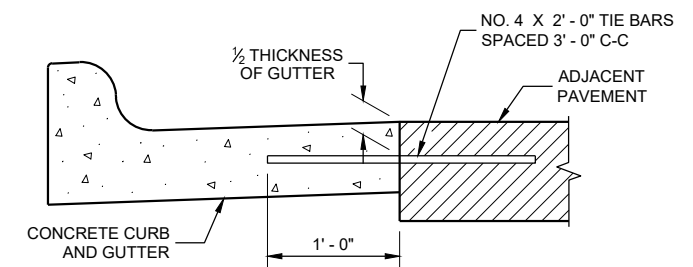

TYPICAL TIE BAR LOCATION ①

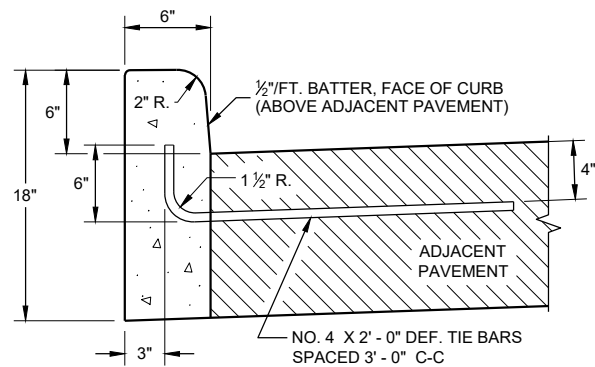

TYPES A ① & D

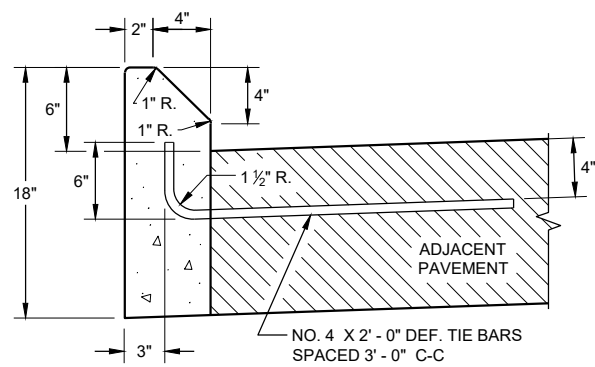

TYPES G ① & J

CONCRETE CURB

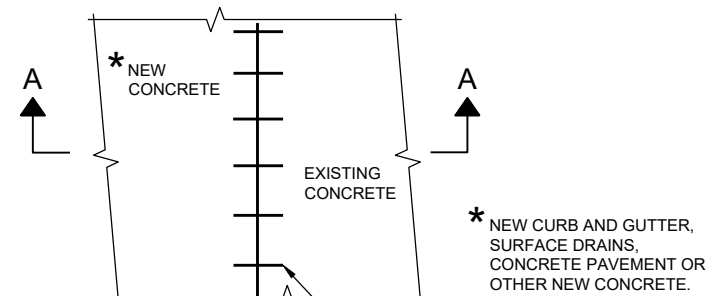

PLAN VIEW

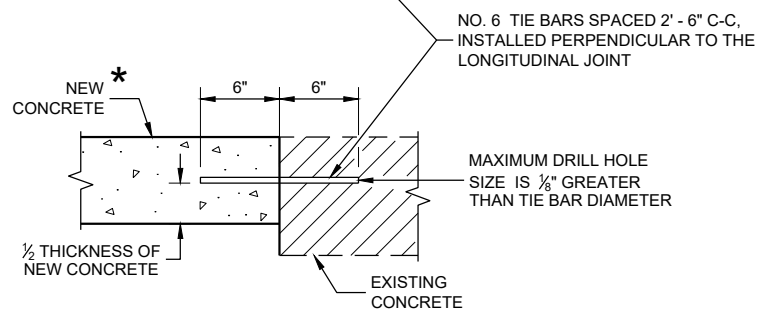

SECTION A - A

TIE BARS DRILLED INTO EXISTING PAVEMENT

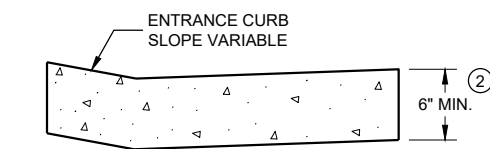

DRIVEWAY ENTRANCE CURB ⑨
(WHEN DIRECTED BY THE ENGINEER)

CONCRETE CURB, TIES AND CURB AND GUTTER APPLICATIONS

STATE OF WISCONSIN
DEPARTMENT OF TRANSPORTATION

APPROVED
February 2021 /S/ Rodney Taylor
DATE ROADWAY STANDARDS DEVELOPMENT ENGINEER

FHWA

NOTE: TAPER CURB ENDS TO GUTTER IN 1' - 0"

ASPHALTIC FLUME

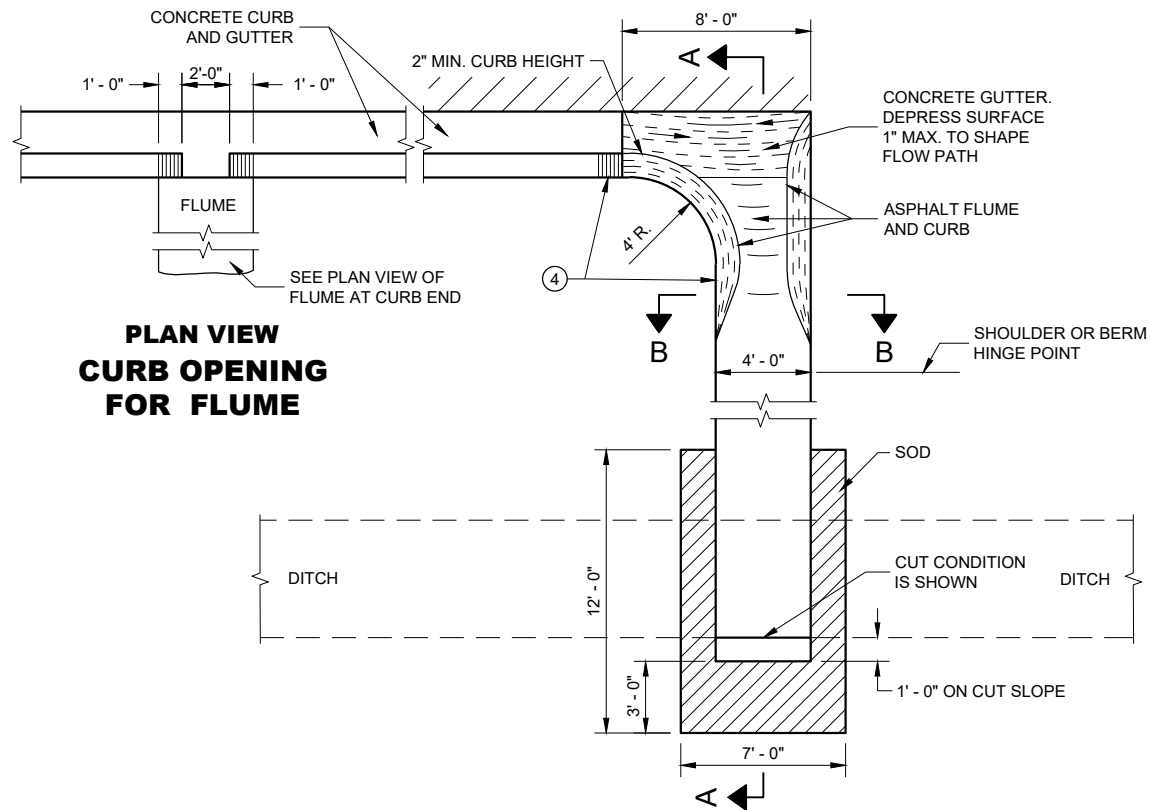

**PLAN VIEW
CURB OPENING
FOR FLUME**

**PLAN VIEW
FLUME AT CURB END**

GENERAL NOTES

DETAILS OF CONSTRUCTION, MATERIALS AND WORKMANSHIP NOT SHOWN ON THIS DRAWING SHALL CONFORM TO PERTINENT REQUIREMENTS OF THE STANDARD SPECIFICATIONS AND APPLICABLE SPECIAL PROVISIONS.

4" X 4" - W3.0 X W3.0 CONCRETE REINFORCEMENT SHALL BE IN ACCORDANCE WITH AASHTO SPECIFICATION M55.

- ① JOINTS SHALL BE 1/8" TO 1/4" WIDE BY 1 1/2" DEEP AND SPACED AT UNIFORM INTERVALS OF APPROXIMATELY 4 FEET.
- ② GEOTEXTILE TYPE "R" SHALL UNDERLAY THE FULL LENGTH AND WIDTH OF THE CONCRETE SURFACE DRAIN AND RIPRAP.
- ③ CONCRETE SURFACE DRAIN WITHOUT CURB AND GUTTER MAY BE USED ON BACKSLOPES WHEN SPECIFIED.
- ④ ANGLE OF FLUME IN RELATION TO BACK OF CURB TO BE CONSTRUCTED PER THE PLAN DETAILS OR AS DIRECTED BY THE ENGINEER. ANGLE OF FLUME MAY BE OTHER THAN 90 DEGREES AS SHOWN.

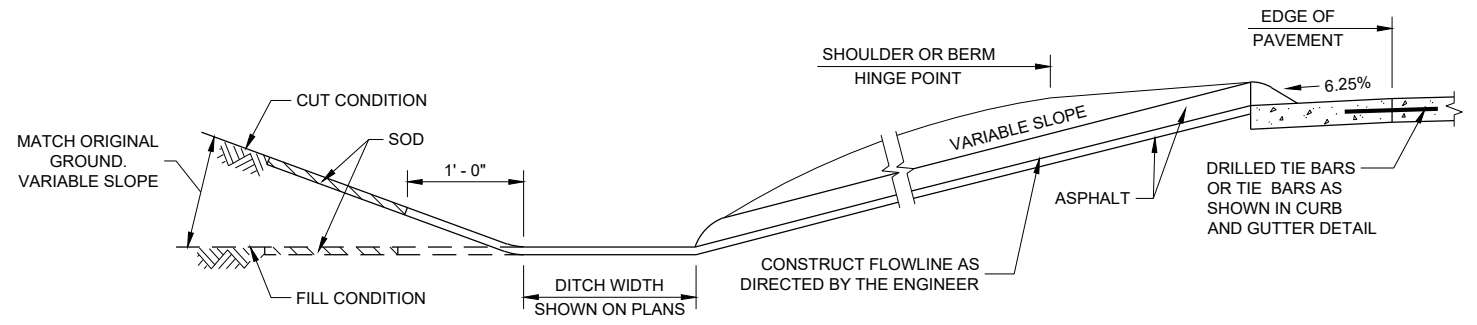

SECTION A - A

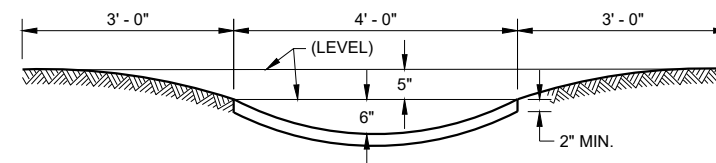

SECTION B - B

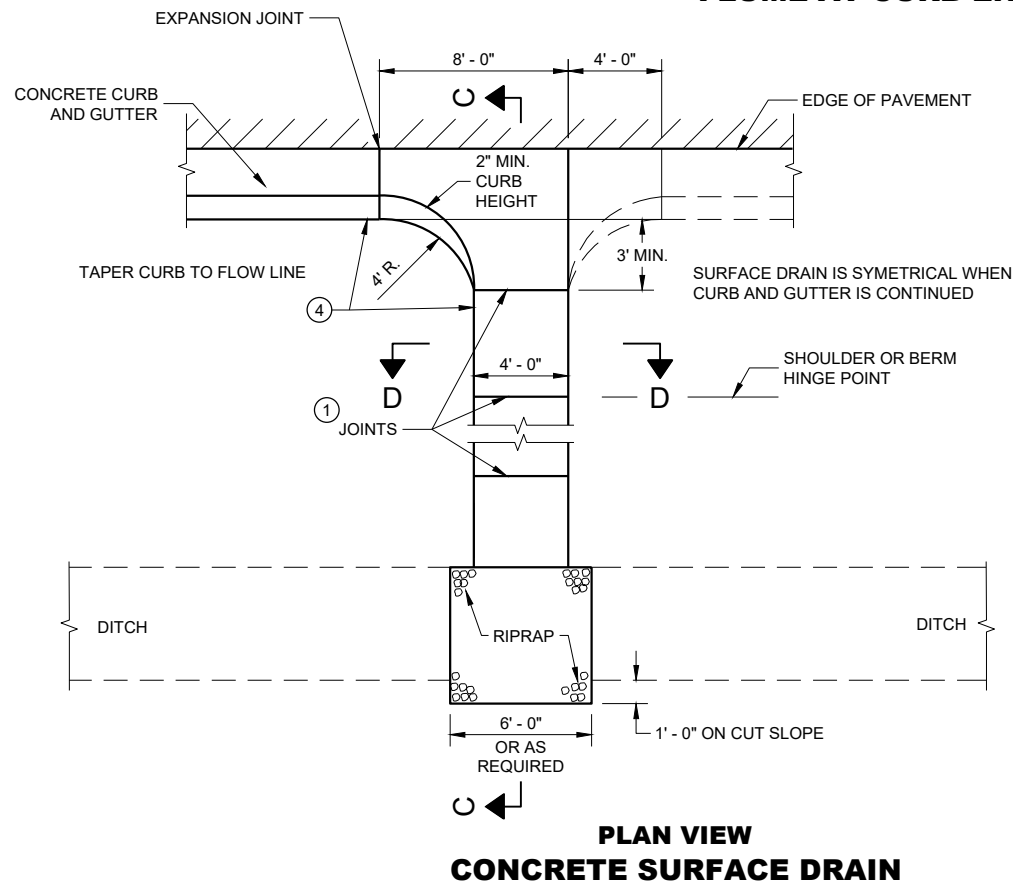

**PLAN VIEW
CONCRETE SURFACE DRAIN**

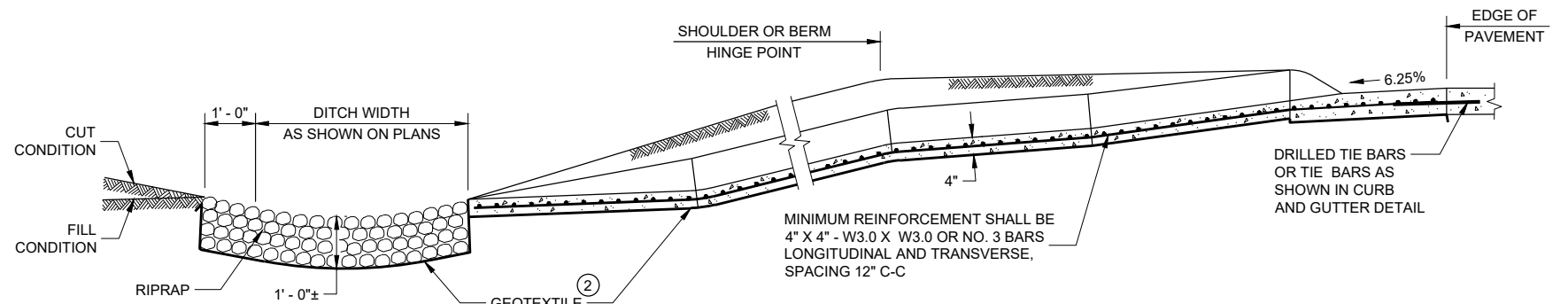

SECTION C - C

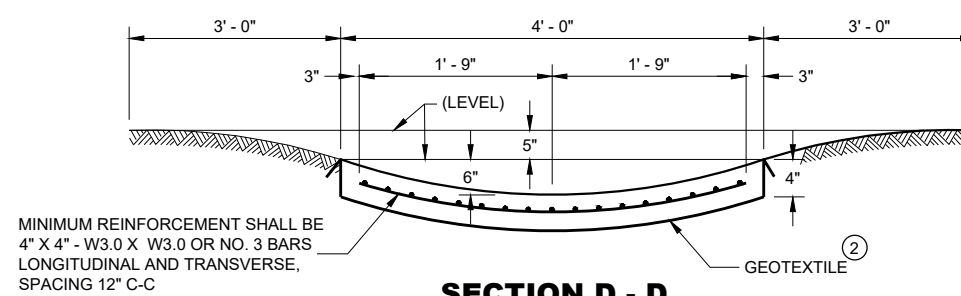

SECTION D - D

CONCRETE SURFACE DRAINS AND ASPHALTIC FLUMES

STATE OF WISCONSIN
DEPARTMENT OF TRANSPORTATION

APPROVED
November 2021 /S/ Rodney Taylor
DATE ROADWAY STANDARDS DEVELOPMENT
ENGINEER
FHWA

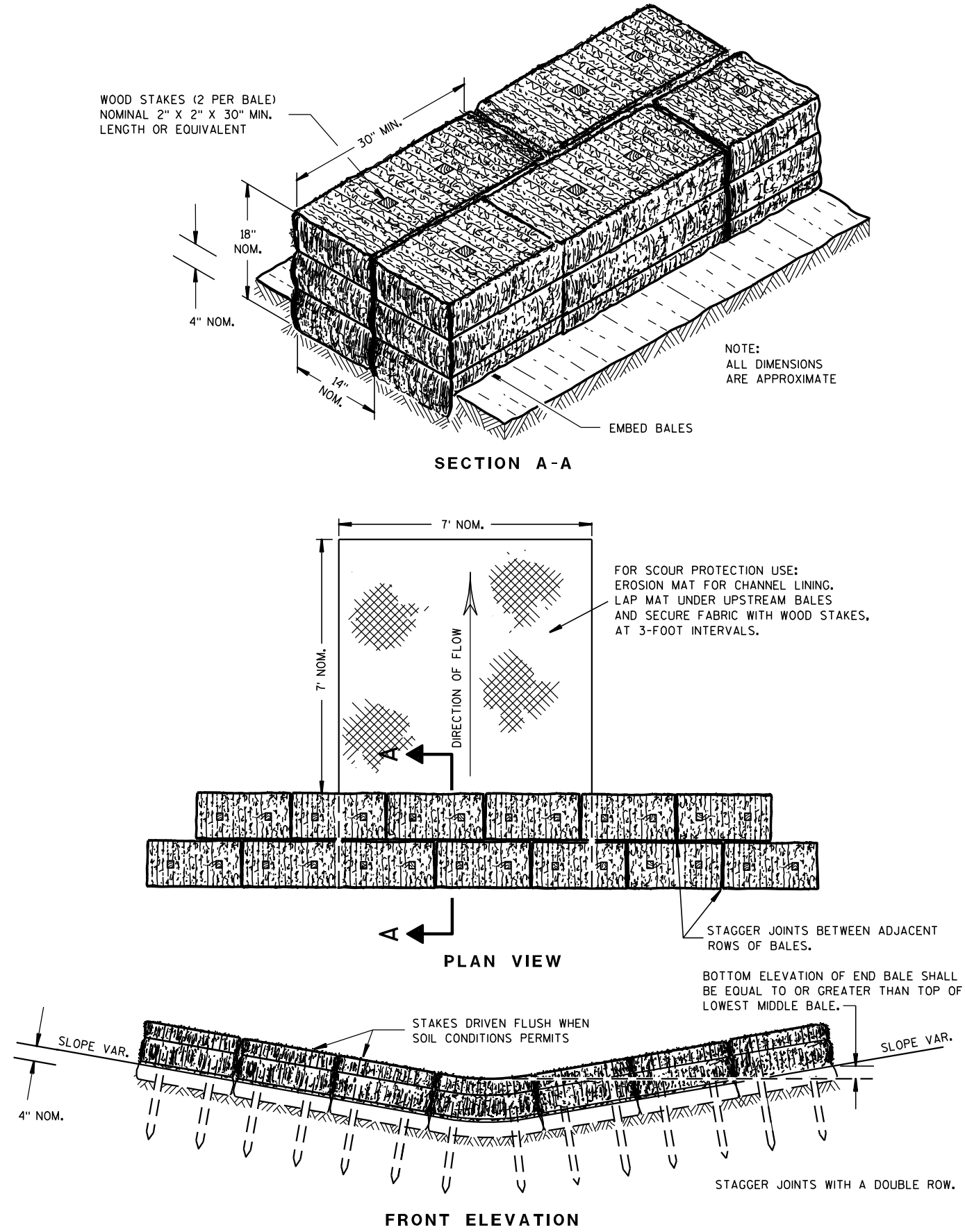

TEMPORARY DITCH CHECK USING EROSION BALES ①

GENERAL NOTES

DETAILS OF CONSTRUCTION, MATERIALS AND WORKMANSHIP NOT SHOWN ON THIS DRAWING SHALL CONFORM TO THE PERTINENT REQUIREMENTS OF THE STANDARD SPECIFICATIONS AND THE APPLICABLE SPECIAL PROVISIONS.

- ① TEMPORARY DITCH CHECKS EITHER EROSION BALES OR MANUFACTURED SHALL BE PAID FOR UNDER THE BID ITEM OF TEMPORARY DITCH CHECK. THE DEPARTMENT WILL NOT PAY FOR TEMPORARY DITCH CHECKS CONSTRUCTED OF A SINGLE ROW OF EROSION BALES.

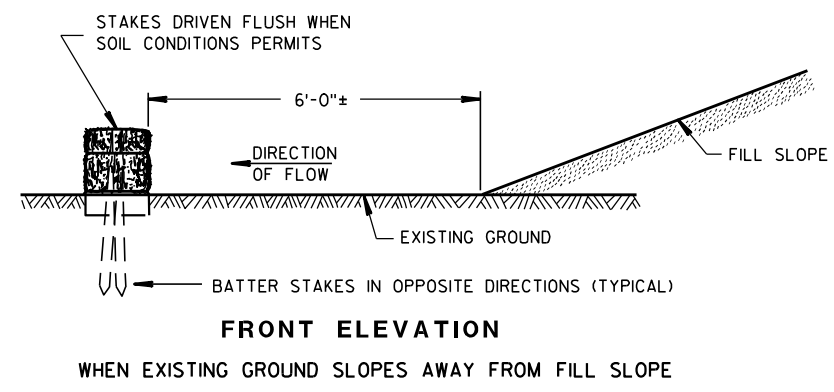
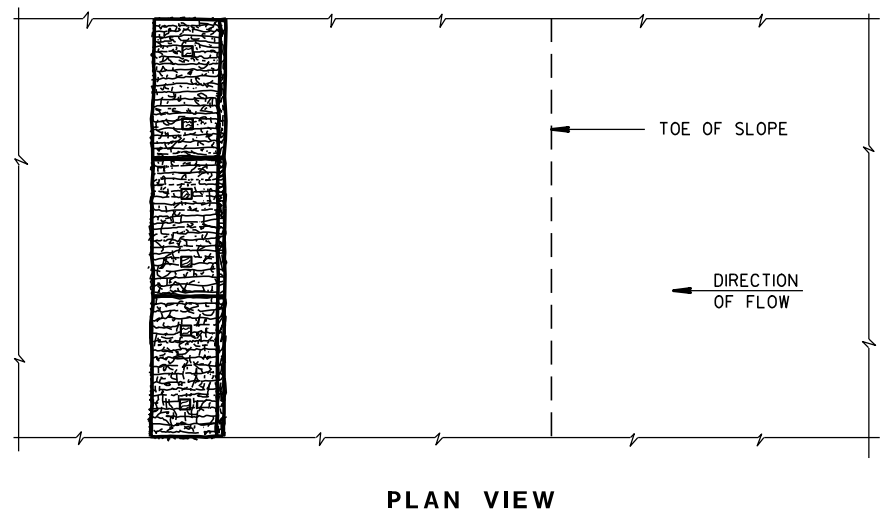
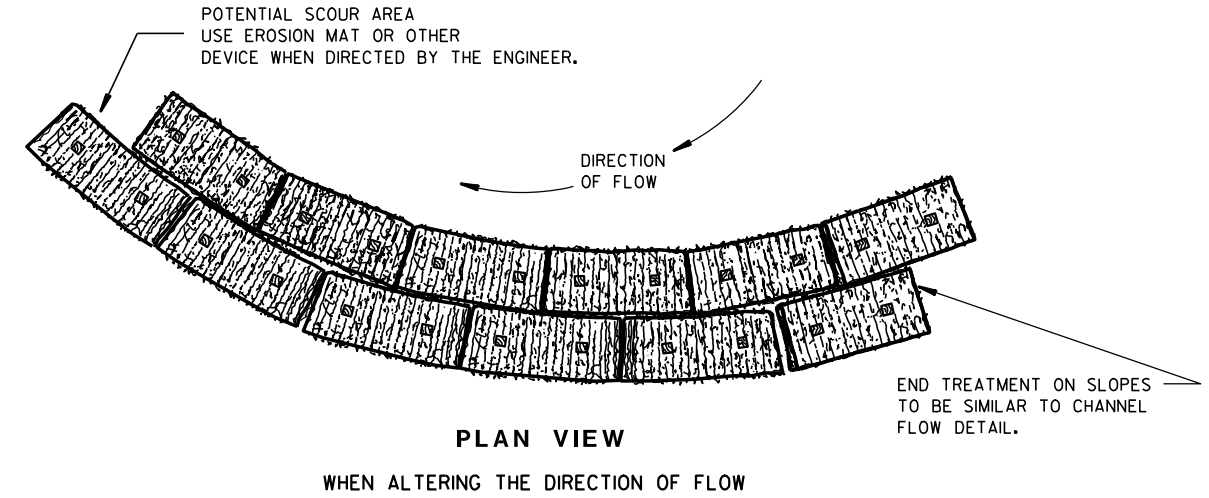

EROSION BALES FOR SHEET FLOW

TYPICAL INSTALLATIONS OF EROSION BALES / TEMPORARY DITCH CHECKS

STATE OF WISCONSIN
DEPARTMENT OF TRANSPORTATION

APPROVED
6/04/02 /S/ Beth Canestra
DATE CHIEF ROADWAY DEVELOPMENT ENGINEER
FHWA

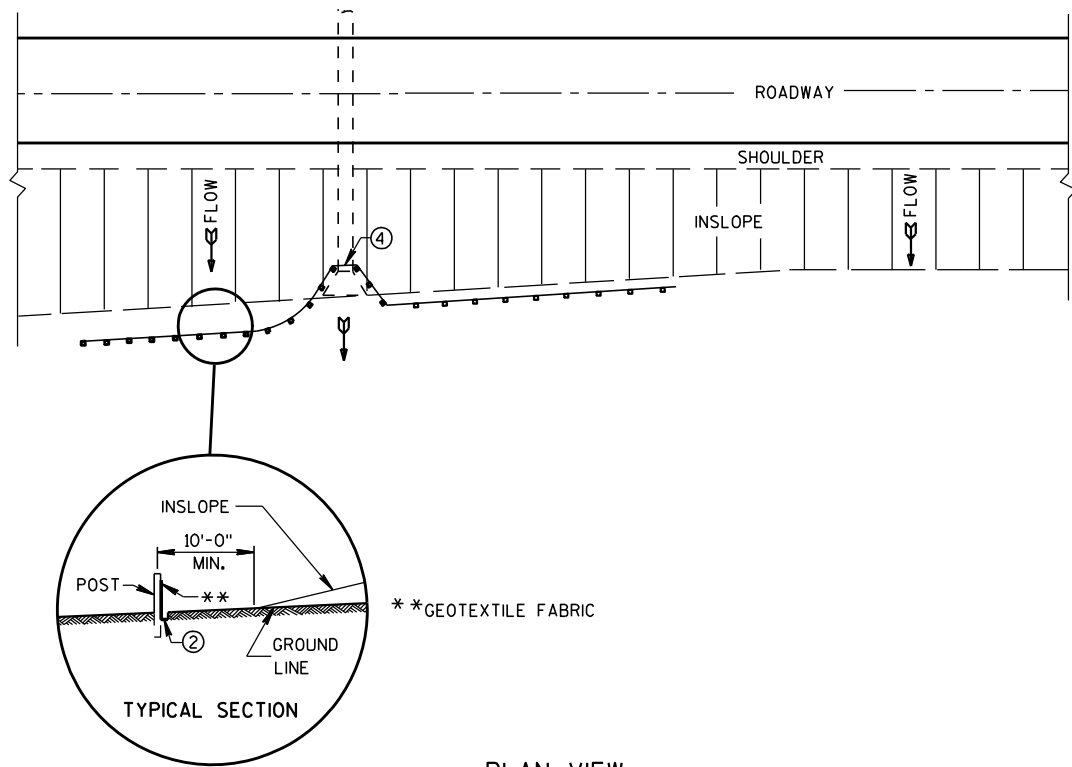

PLAN VIEW
TYPICAL APPLICATION OF SILT FENCE

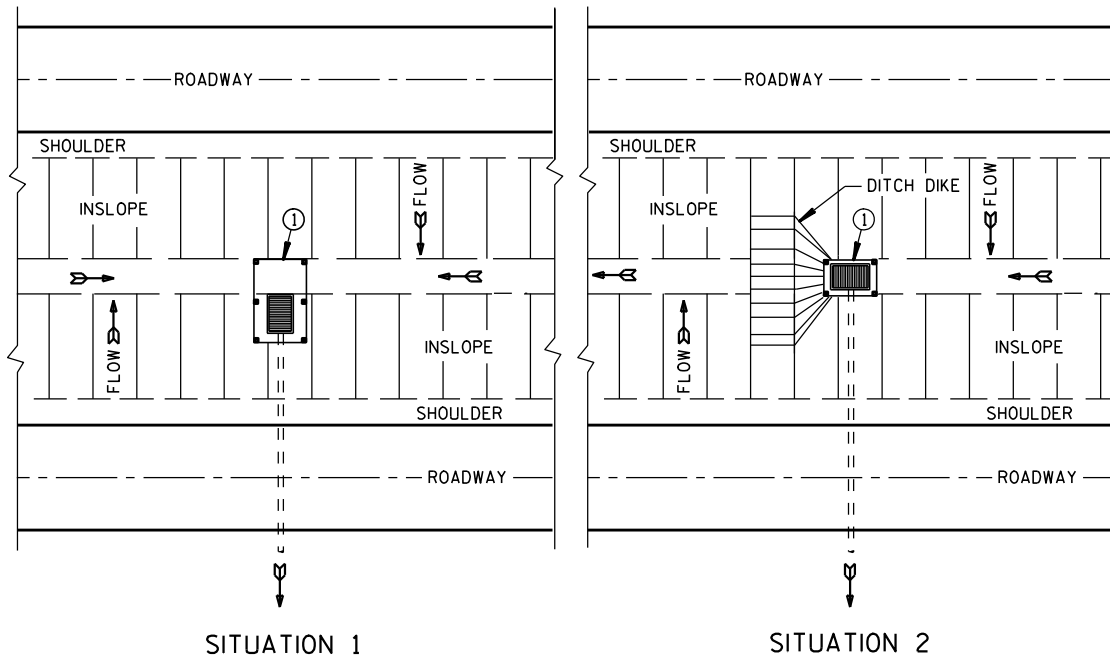

SITUATION 1 SITUATION 2
PLAN VIEW
SILT FENCE AT MEDIAN SURFACE DRAINS

GENERAL NOTES

DETAILS OF CONSTRUCTION NOT SHOWN ON THIS DRAWING SHALL CONFORM TO THE PERTINENT REQUIREMENTS OF THE STANDARD SPECIFICATIONS AND APPLICABLE SPECIAL PROVISIONS.

- ① HORIZONTAL BRACE REQUIRED WITH 2" X 4" WOODEN FRAME OR EQUIVALENT AT TOP OF POSTS.
- ② FOR MANUAL INSTALLATIONS THE TRENCH SHALL BE A MINIMUM OF 4" WIDE & 6" DEEP TO BURY AND ANCHOR THE GEOTEXTILE FABRIC. FOLD MATERIAL TO FIT TRENCH AND BACKFILL & COMPACT TRENCH WITH EXCAVATED SOIL.
- ③ WOOD POSTS SHALL BE A MINIMUM SIZE OF 1 1/8" X 1 1/8" OF OAK OR HICKORY.
- ④ SILT FENCE TO EXTEND ACROSS THE TOP OF THE PIPE.
- ⑤ CONSTRUCT SILT FENCE FROM A CONTINUOUS ROLL IF POSSIBLE BY CUTTING LENGTHS TO AVOID JOINTS. IF A JOINT IS NECESSARY USE ONE OF THE FOLLOWING TWO METHODS; A) OVERLAP THE END POSTS AND TWIST, OR ROTATE, AT LEAST 180 DEGREES, B) HOOK THE END OF EACH SILT FENCE LENGTH.

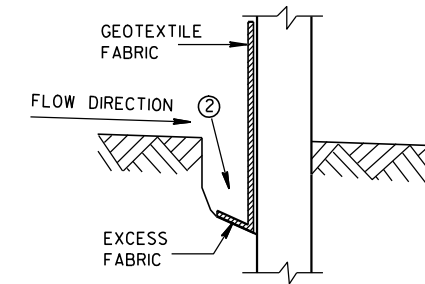

TRENCH DETAIL

NOTE: ADDITIONAL POST DEPTH OR TIE BACKS MAY BE REQUIRED IN UNSTABLE SOILS

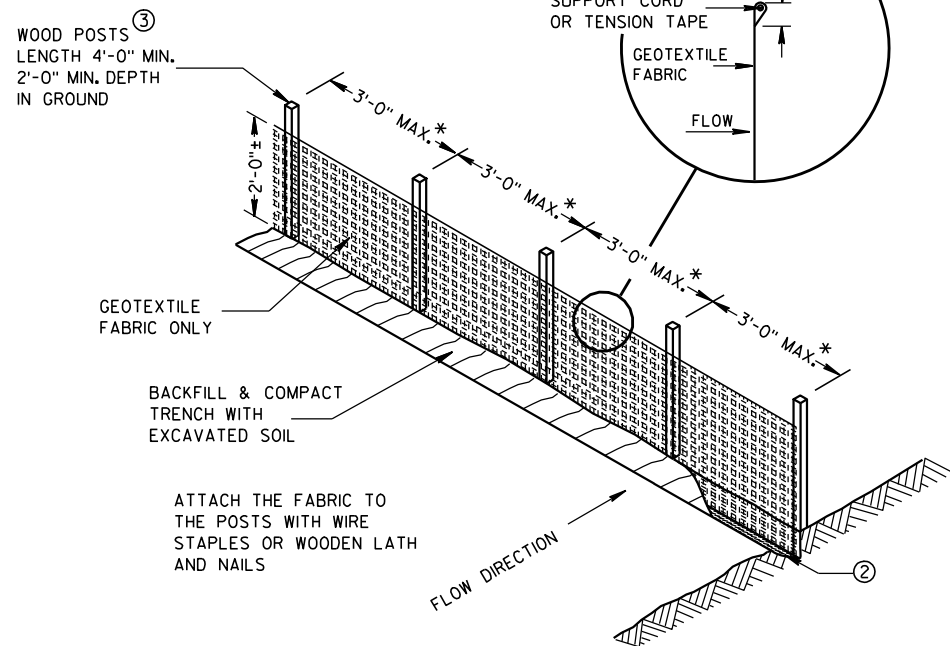

SILT FENCE

* NOTE: 8'-0" POST SPACING ALLOWED IF A WOVEN GEOTEXTILE FABRIC IS USED.

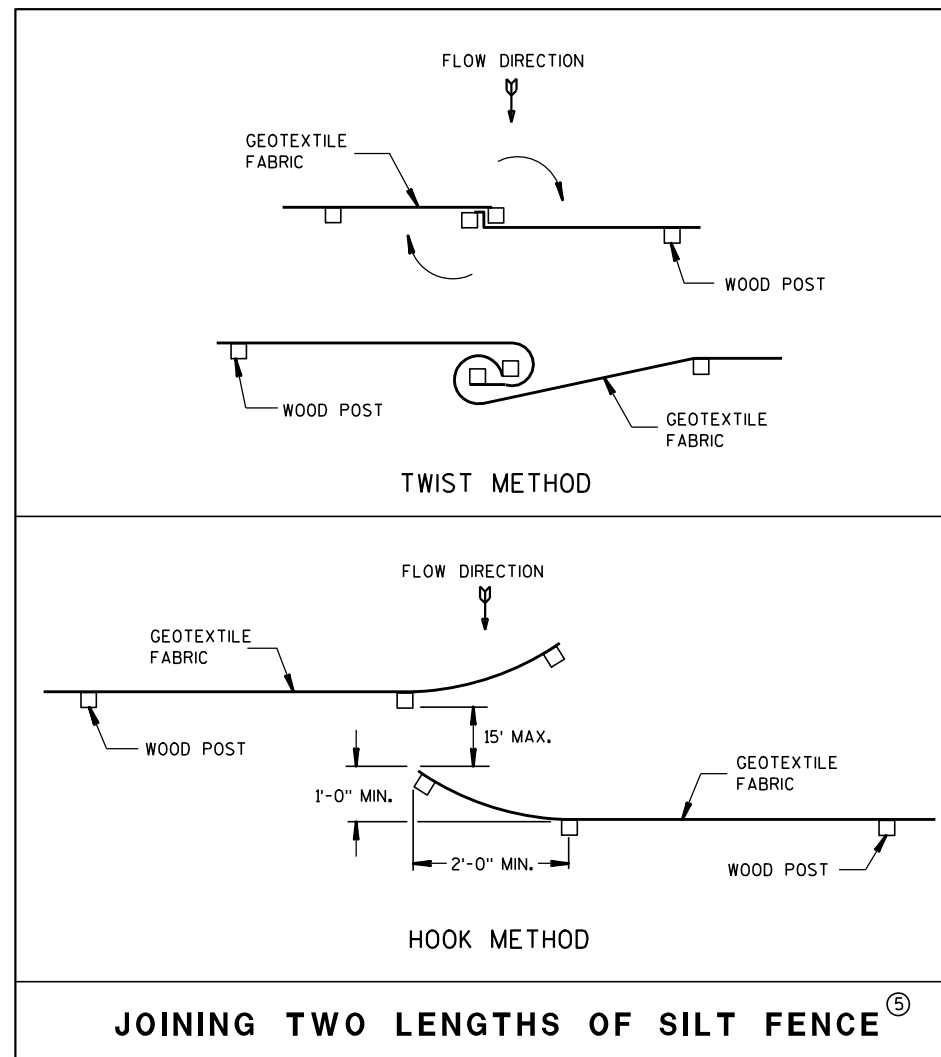

JOINING TWO LENGTHS OF SILT FENCE ⑤

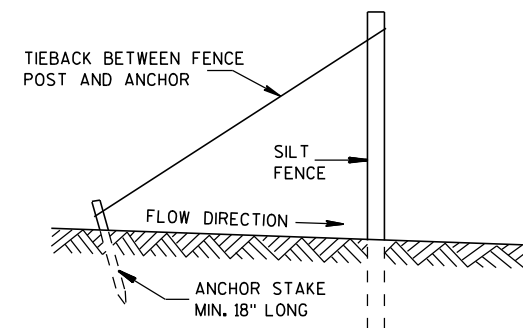

SILT FENCE TIE BACK
(WHEN REQUIRED BY THE ENGINEER)

SILT FENCE

STATE OF WISCONSIN
DEPARTMENT OF TRANSPORTATION

APPROVED
4-29-05 /S/ Beth Canestra
DATE CHIEF ROADWAY DEVELOPMENT ENGINEER
FHWA

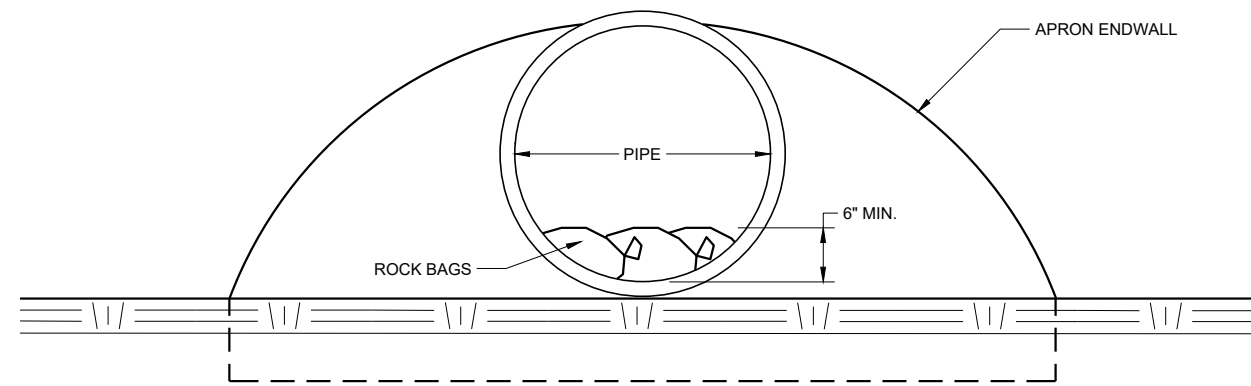

END VIEW

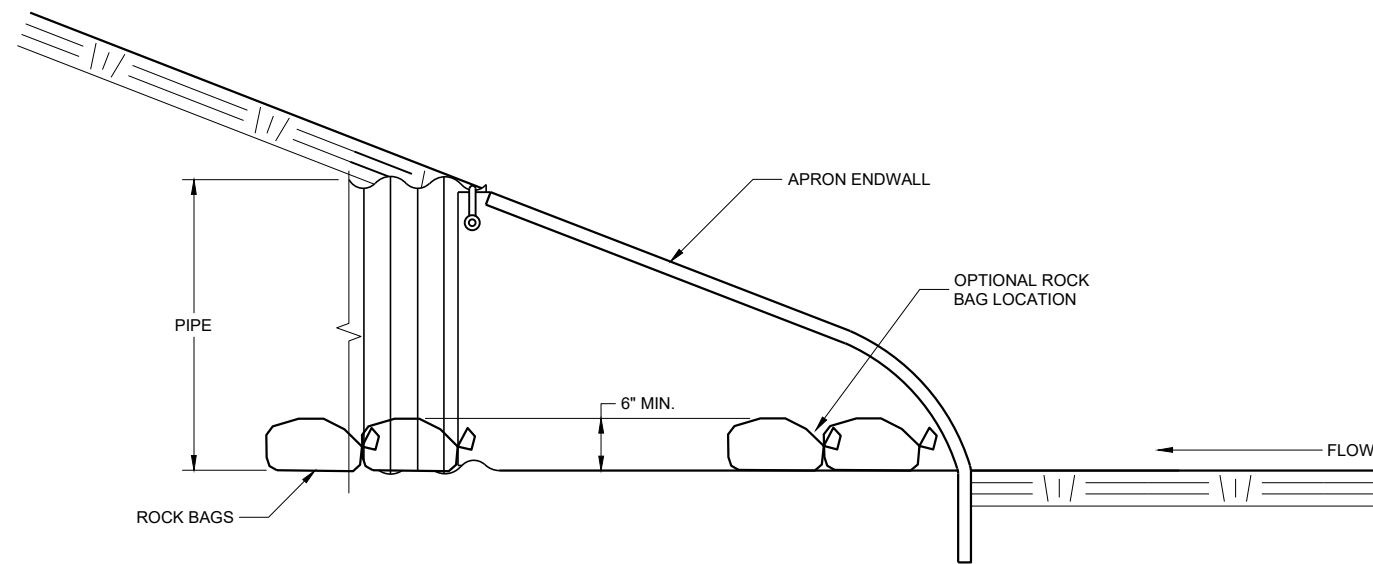

SIDE VIEW

CULVERT PIPE CHECK
(INSTALL ON INLET END ONLY)

6

6

SDD 08E15 - 01

SDD 08E15 - 01

CULVERT PIPE CHECK	
STATE OF WISCONSIN DEPARTMENT OF TRANSPORTATION	
APPROVED May 2019 DATE	/S/ Daniel Schave EROSION CONTROL ENGINEER
<small>FHWA</small>	

METAL APRON ENDWALLS											
PIPE DIA. (IN.)	MIN. THICK. (Inches)		DIMENSIONS (Inches)							APPROX. SLOPE	BODY
	STEEL	ALUM.	A (±1")	B (MAX.)	H (±1")	L (±1 1/2")	L1	L2	W (±2")		
12	.064	.060	6	6	6	21	12	17 1/2	24	2 1/2 to 1	1 Pc.
15	.064	.060	7	8	6	26	14	21 3/4	30	2 1/2 to 1	1 Pc.
18	.064	.060	8	10	6	31	15	28 1/4	36	2 1/2 to 1	1 Pc.
21	.064	.060	9	12	6	36	18	29 5/8	42	2 1/2 to 1	1 Pc.
24	.064	.075	10	13	6	41	18	37 1/4	48	2 1/2 to 1	1 Pc.
30	.079	.075	12	16	8	51	18	52 1/4	60	2 1/2 to 1	1 Pc.
36	.079	.105	14	19	9	60	24	59 3/4	72	2 1/2 to 1	2 Pc.
42	.109	.105	16	22	11	69	24	75 5/8	84	2 1/2 to 1	2 Pc.
48	.109	.105	18	27	12	78	24	81	90	2 1/4 to 1	3 Pc.
54	.109	.105	18	30	12	84	30	85 1/2	102	2 1/4 to 1	3 Pc.
60	.109x	.105x	18	33	12	87	—	—	114	2 to 1	3 Pc.
66	.109x	.105x	18	36	12	87	—	—	120	2 to 1	3 Pc.
72	.109x	.105x	18	39	12	87	—	—	126	2 to 1	3 Pc.
78	.109x	.105x	18	42	12	87	—	—	132	1 1/2 to 1	3 Pc.
84	.109x	.105x	18	45	12	87	—	—	138	1 1/2 to 1	3 Pc.
90	.109x	.105x	18	37	12	87	—	—	144	1 1/2 to 1	3 Pc.
96	.109x	.105x	18	35	12	87	—	—	150	1 1/2 to 1	3 Pc.

* EXCEPT CENTER PANEL SEE GENERAL NOTES

REINFORCED CONCRETE APRON ENDWALLS									
PIPE DIA. (IN.)	DIMENSIONS (Inches)							APPROX. SLOPE	
	T	A	B	C	D	E	G		
12	2	4	24	48 1/8	72 1/8	24	2	3 to 1	
15	2 1/4	6	27	46	73	30	2 1/4	3 to 1	
18	2 1/2	9	27	46	73	36	2 1/2	3 to 1	
21	2 3/4	9	36	37 1/2	73 1/2	42	2 3/4	3 to 1	
24	3	9 1/2	43 1/2	30	73 1/2	48	3	3 to 1	
27	3 1/4	10 1/2	49 1/2	24	73 1/2	54	3 1/4	3 to 1	
30	3 1/2	12	54	19 3/4	73 1/2	60	3 1/2	3 to 1	
36	4	15	63	34 3/4	97 3/4	72	4	3 to 1	
42	4 1/2	21	63	35	98	78	4 1/2	3 to 1	
48	5	24	72	26	98	84	5	3 to 1	
54	5 1/2	27	65	33 1/4-35	98 1/4-100	90	5 1/2	2 1/2 to 1	
60	6	30-35	60	39	99	96	5	2 to 1	
66	6 1/2	24-30	72-78	21-27	99	102	5 1/2	2 to 1	
72	7	24-36	78	21	99	108	6	2 to 1	
78	7 1/2	24-36	78	21	99	114	6 1/2	2 to 1	
84	8	36	90 1/2	21	111 1/2	120	6 1/2	1 1/2 to 1	
90	8 1/2	41	87 1/2	24	111 1/2	132	6 1/2	1 1/2 to 1	

* MINIMUM
** MAXIMUM

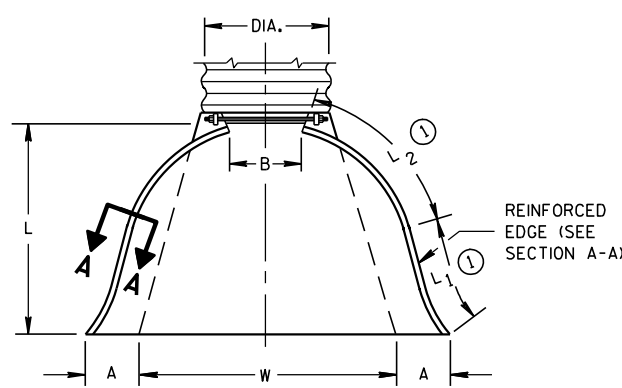

PLAN VIEW

REINFORCED EDGE (SEE SECTION A-A)
END CORNER PLATES MAY BE FASTENED TO APRON PROPER BY BOLTS, RIVETS, OR RESISTANCE SPOT WELDS WHICH WILL HOLD THE SURFACES TIGHTLY TOGETHER

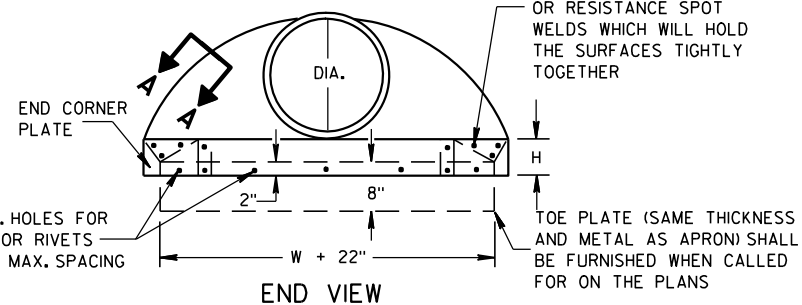

END VIEW

7/16" DIA. HOLES FOR BOLTS OR RIVETS 12" C-C MAX. SPACING

TOE PLATE (SAME THICKNESS AND METAL AS APRON) SHALL BE FURNISHED WHEN CALLED FOR ON THE PLANS

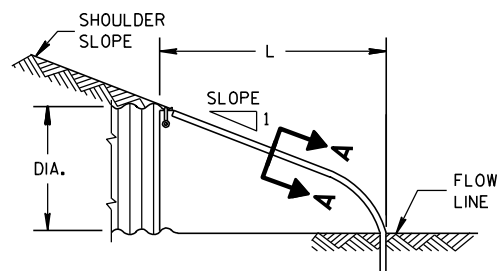

SIDE ELEVATION
METAL ENDWALLS

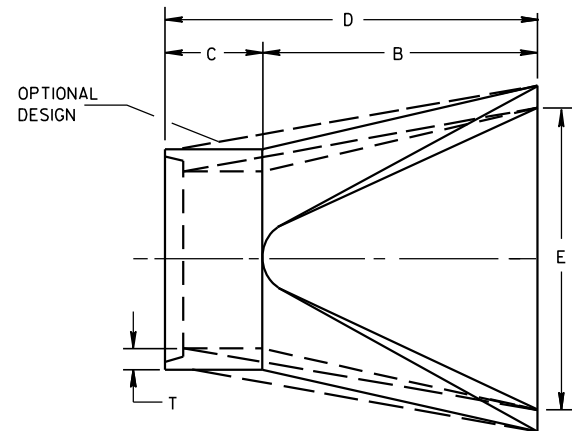

PLAN

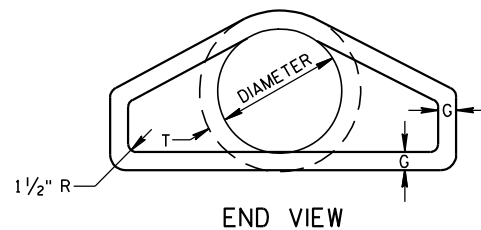

END VIEW

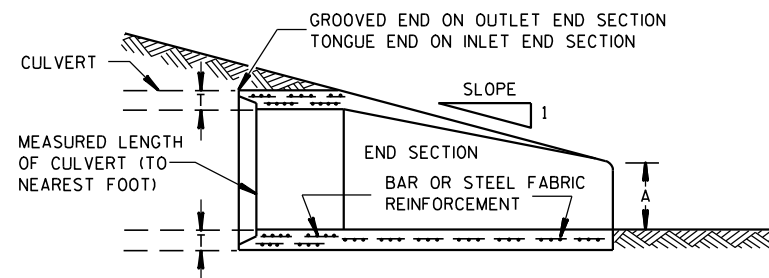

LONGITUDINAL SECTION
CONCRETE ENDWALLS

1" WIDE, 12 GA. (0.109" THICK) GALVANIZED STRAP WITH STANDARD 6" X 1/2" BAND BOLT AND NUT

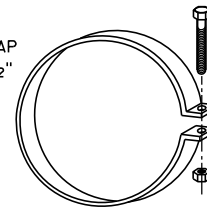

ALTERNATE FOR TYPE 1 CONNECTION
END SECTION CONNECTOR STRAP

THREADED 7/16" DIA. ROD AROUND CULVERT & THROUGH TANK TYPE CONNECTOR LUG OR ALTERNATE CONNECTOR STRAP (SEE DETAIL)

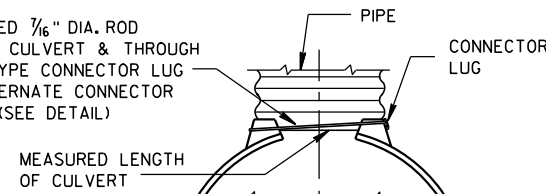

TYPE 1
FOR 12" THRU 24" CORR. PIPE

THREADED 7/16" DIA. ROD OVER TOP OF APRON, SIDE LUGS TO BE RIVETED TO APRON



TYPE 2
FOR 30" THRU 96" CORR. PIPE

MEASURED LENGTH OF CULVERT
CONNECTOR SECTION TO BE PAID FOR AS PART OF END SECTION

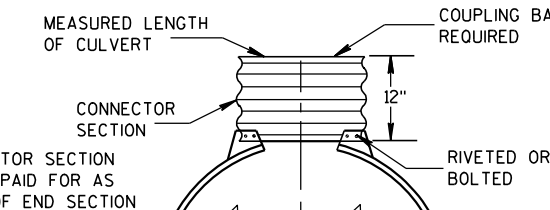

TYPE 3
FOR 42" THRU 96" CORR. PIPE

DIMPLED OR CORRUGATED COUPLING BAND
RIVETED OR BOLTED AT DIMPLES (6" C-C FOR CORRUGATED BAND)

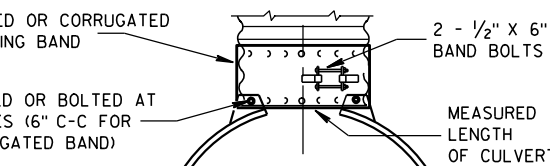

TYPE 5
ALTERNATE FOR:
ALL SIZES CORRUGATED CIRCULAR PIPE

NOTE: DIMPLED BAND FITS OVER OUTSIDE OF ENDWALL, AND CORRUGATED BAND FITS INSIDE ENDWALL. DIMPLED BAND MAY BE USED WITH HELICALLY CORRUGATED PIPE.

FOR CIRCUMFERENTIALLY CORRUGATED PIPE USE ENDWALL CONNECTION DETAILS 1, 2, 3 OR 5 AS APPLICABLE.

FOR HELICALLY CORRUGATED PIPE USE ENDWALL CONNECTION DETAILS 1, 2 OR 5.

FOR HELICALLY CORRUGATED PIPES WITH TWO CIRCUMFERENTIAL CORRUGATIONS AT EACH END USE ENDWALL CONNECTION DETAILS 1, 2 OR 3.

CONNECTION DETAILS

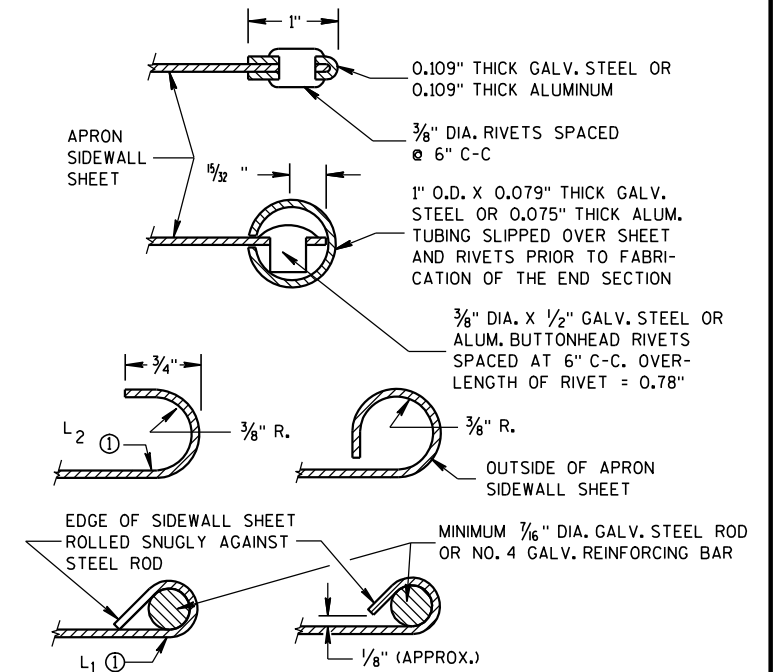

SECTION A-A

GENERAL NOTES

DETAILS OF CONSTRUCTION, MATERIALS AND WORKMANSHIP NOT SHOWN ON THIS DRAWING SHALL CONFORM TO THE PERTINENT REQUIREMENTS OF THE STANDARD SPECIFICATIONS AND THE APPLICABLE SPECIAL PROVISIONS.

CONCRETE CULVERT ENDWALLS MAY NOT BE USED WITH GALVANIZED STEEL OR ALUMINUM CULVERT PIPE OR VICE VERSA. GALVANIZED STEEL OR ALUMINUM ENDWALLS SHALL NORMALLY BE INSTALLED ON CULVERT PIPE OF THE SAME METAL.

ALL THREE PIECE STEEL APRON ENDWALLS FOR 60" DIAMETER PIPE AND LARGER SHALL HAVE 0.109" SIDES AND 0.138" CENTER PANELS. ALL THREE PIECE ALUMINUM APRON ENDWALLS FOR 60" DIAMETER PIPE AND LARGER SHALL HAVE 0.105" SIDES AND 0.134" CENTER PANELS. THE WIDTH OF CENTER PANELS SHALL BE GREATER THAN 20 PERCENT OF THE PIPE PERIMETER.

LAP SEAMS SHALL BE TIGHTLY JOINED BY GALVANIZED RIVETS OR BOLTS FOR STEEL UNITS AND ALUMINUM RIVETS AND BOLTS FOR ALUMINUM UNITS. FOR THE 60" THROUGH 96" DIAMETER APRON ENDWALL SIZES, THE REINFORCED EDGES AND CENTER PANEL SEAMS SHALL BE FURTHER REINFORCED WITH GALVANIZED STEEL OR ALUMINUM STIFFENER ANGLES. THE ANGLES SHALL BE ATTACHED BY GALVANIZED NUTS AND BOLTS FOR STEEL UNITS AND ALUMINUM NUTS AND BOLTS FOR ALUMINUM UNITS.

WHERE TWO OR MORE PIPES WITH APRON ENDWALLS ARE LAID ADJACENT TO EACH OTHER, THEY SHALL BE SEPARATED BY A DISTANCE SUFFICIENT TO PROVIDE A MINIMUM CLEARANCE OF 6 INCHES BETWEEN APRON ENDWALLS.

① FOR PIPE SIZES UP TO 60" DIAMETER, A 180° ROLLED EDGE MAY BE USED INSTEAD OF STEEL ROD REINFORCEMENT. SEE SECTION A-A.

APRON ENDWALLS FOR CULVERT PIPE

STATE OF WISCONSIN
DEPARTMENT OF TRANSPORTATION

APPROVED
11/30/94 DATE /S/ Rory L. Rhinesmith
DATE /S/ RORY L. RHINESMITH
CHIEF ROADWAY DEVELOPMENT ENGINEER
FHWA

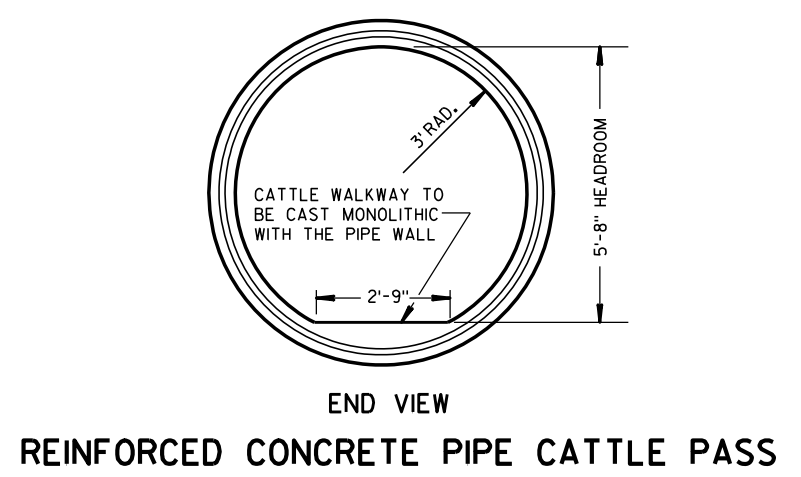
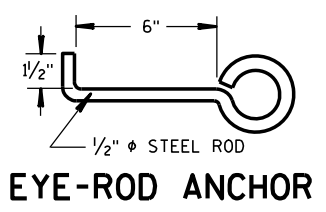
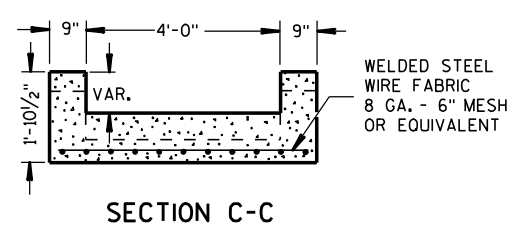
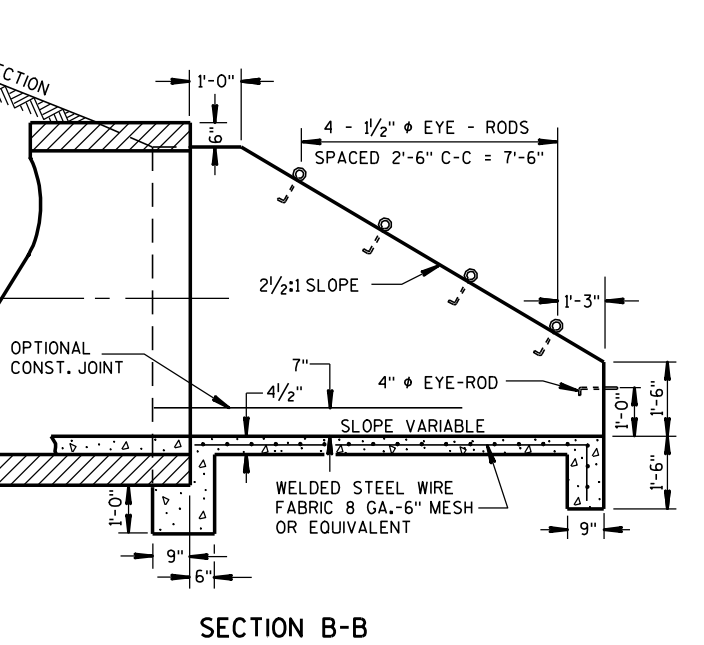
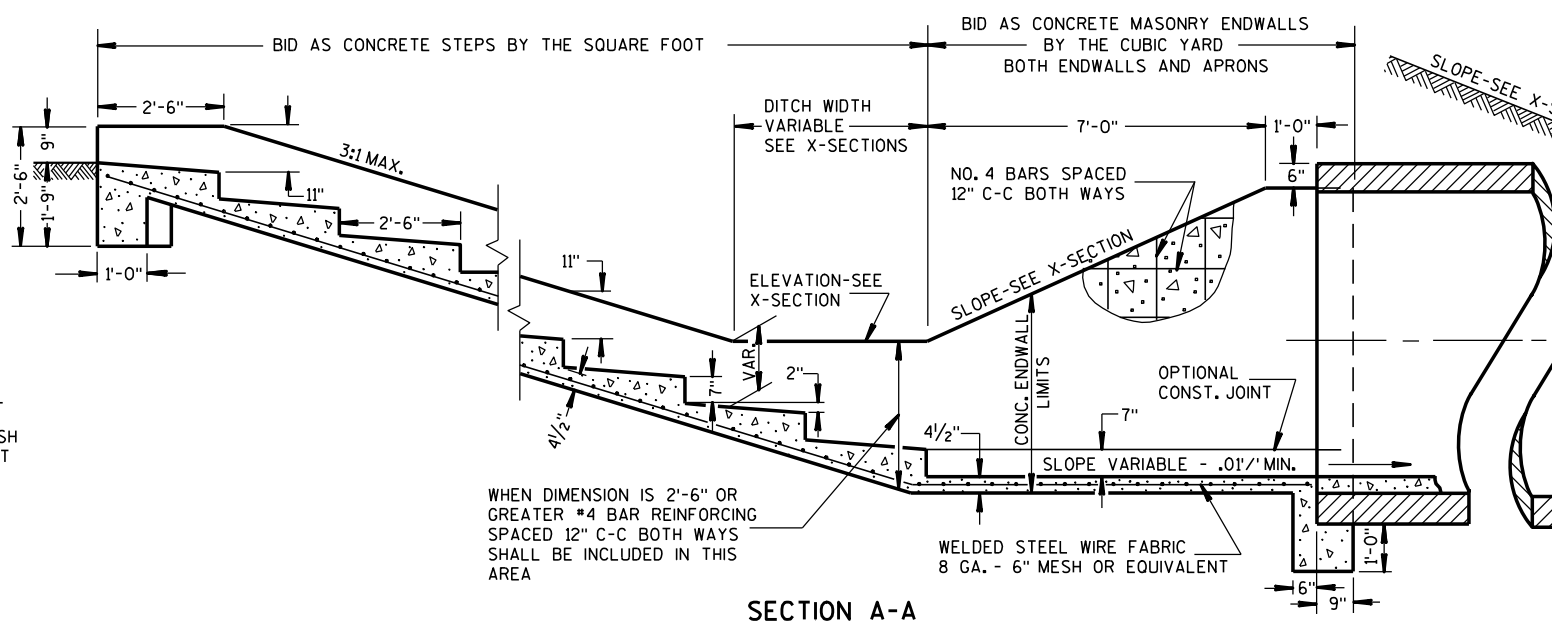
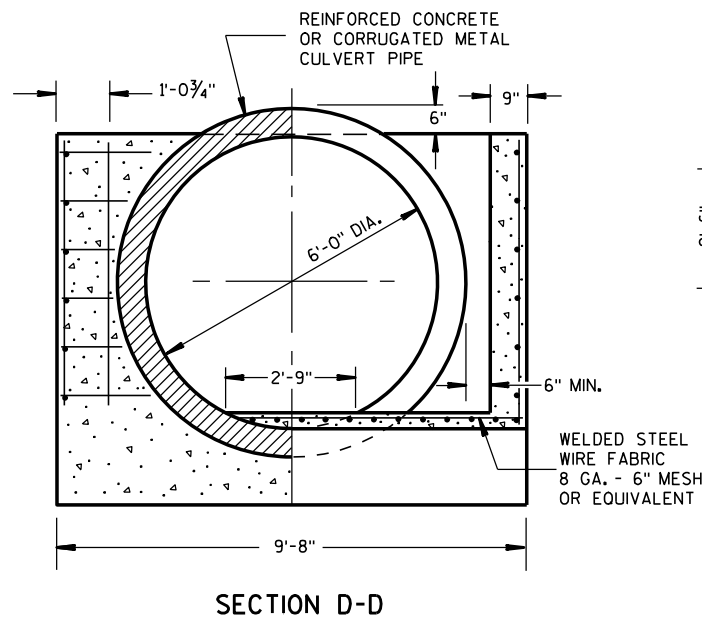
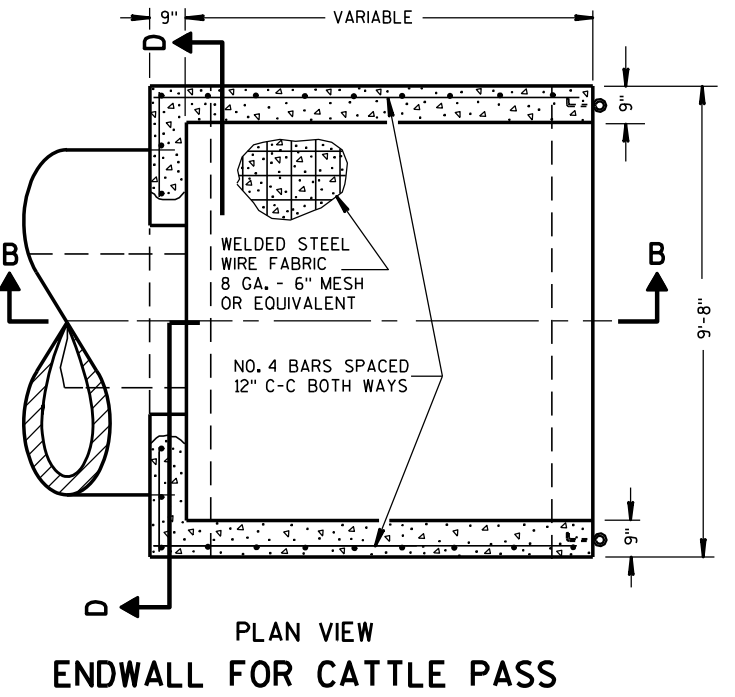
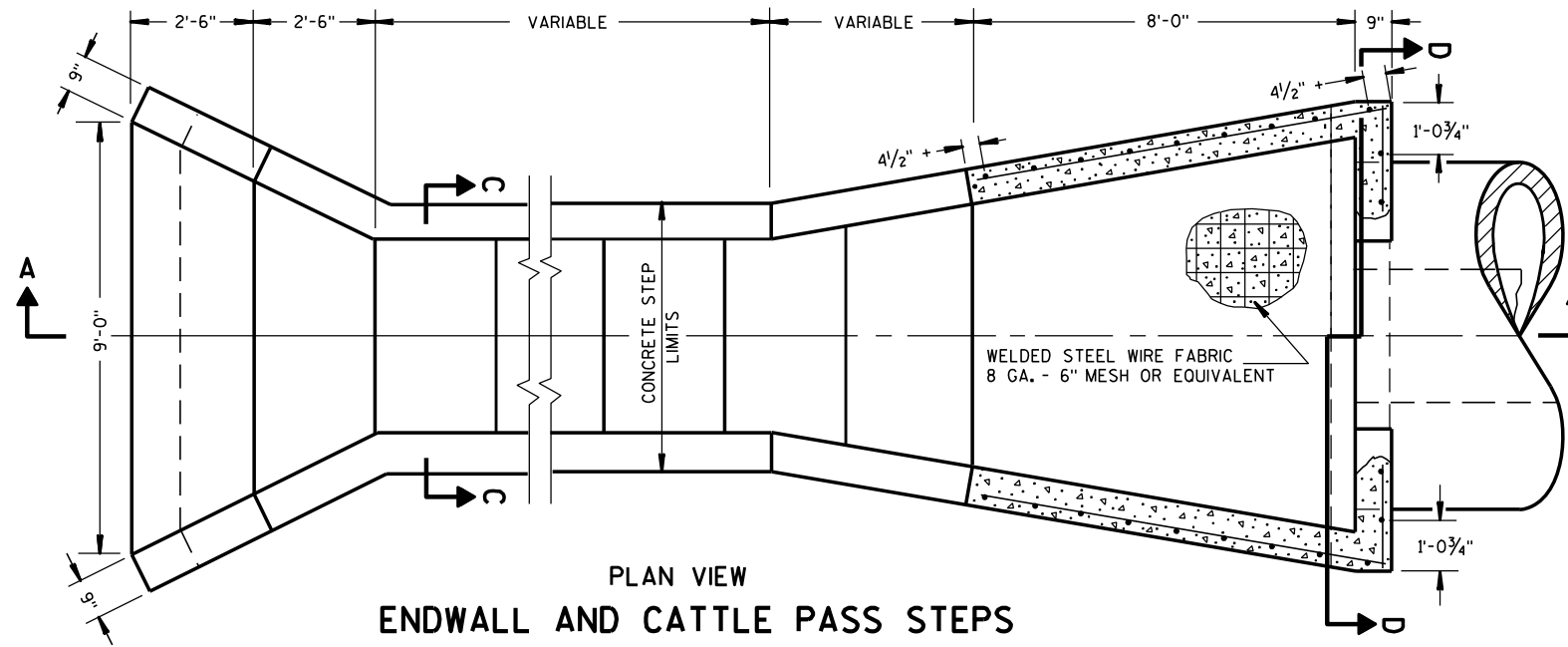
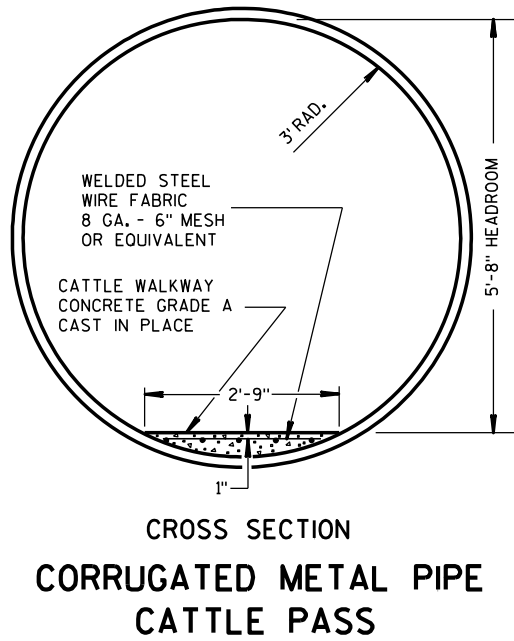

GENERAL NOTES

- DETAILS OF CONSTRUCTION, MATERIALS AND WORKMANSHIP NOT SHOWN ON THIS DRAWING SHALL CONFORM TO THE PERTINENT REQUIREMENTS OF THE STANDARD SPECIFICATIONS AND THE APPLICABLE SPECIAL PROVISIONS.
- ALL STEEL REINFORCEMENT IN ENDWALLS AND CATTLE PASS STEPS SHALL BE EMBEDDED 2 INCHES CLEAR UNLESS OTHERWISE NOTED.
- ALL STEEL REINFORCEMENT OR FABRIC USED AS SHOWN ABOVE SHALL BE INCIDENTAL TO THE BID ITEM OF WHICH IT IS AN INTEGRAL PART.
- EYE-RODS FOR FENCE CONNECTIONS SHALL BE PROVIDED BY THE CONTRACTOR AS AN INCIDENTAL TO THE BID ITEM OF CONCRETE MASONRY, ENDWALLS AND SHALL BE GALVANIZED.
- CONCRETE USED FOR THE CATTLE WALKWAY WITHIN THE PIPE SHALL BE INCIDENTAL TO THE BID ITEM OF PIPE CATTLE PASS.

DETAILS FOR PIPE CATTLE PASS, CONCRETE ENDWALL AND STEPS	
STATE OF WISCONSIN DEPARTMENT OF TRANSPORTATION	
APPROVED 6/6/75 DATE	/s/ Harold Felder STATE DESIGN ENGINEER FOR HWYS
FHWA	

6

6

S.D.D. 8 F 3-3

S.D.D. 8 F 3-3

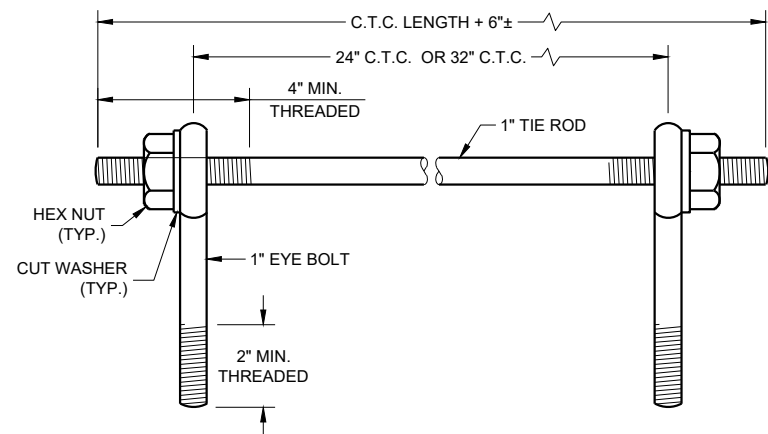

EYE BOLTS AND TIE ROD

EYE BOLT AND TIE ROD ASSEMBLY (ALTERNATE NO. 1)

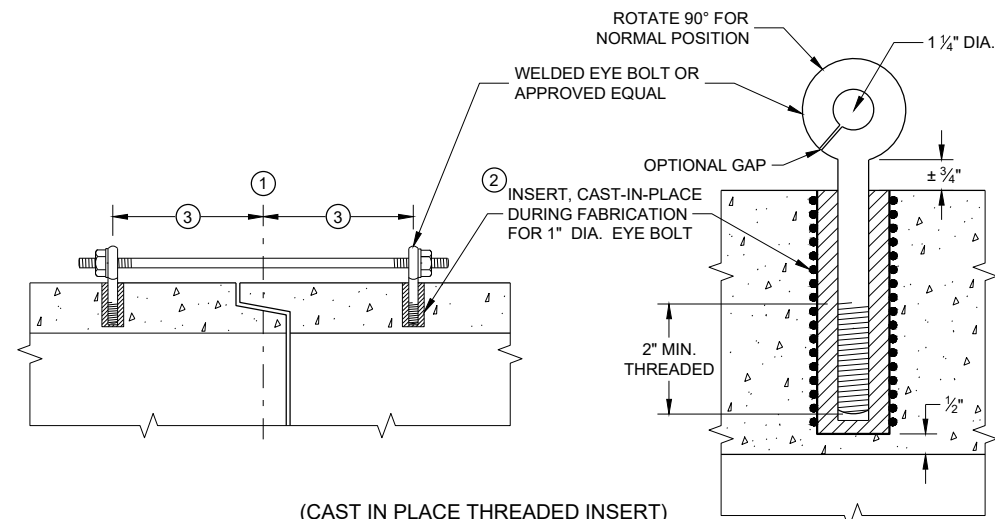

(CAST IN PLACE THREADED INSERT)
LONGITUDINAL SECTIONS

GENERAL NOTES

DETAILS OF CONSTRUCTION, MATERIALS, AND WORKMANSHIP NOT SHOWN ON THIS DRAWING SHALL CONFORM TO THE PERTINENT REQUIREMENTS OF THE STANDARD SPECIFICATIONS AND APPLICABLE SPECIAL PROVISIONS.

CONCRETE CULVERT AND STORM SEWER PIPE SHALL BE TIED TOGETHER IN THE MANNER ILLUSTRATED BY THIS DETAIL AT LOCATIONS DESIGNATED IN THE STANDARD SPECIFICATIONS AND THE PLAN. THE CONTRACTOR MAY USE EITHER ALTERNATE 1, 2 OR 3 FOR DRAINAGE STRUCTURES. ONLY ALTERNATE 1 AND 3 MAY BE USED FOR CATTLE PASSES, UNLESS OTHERWISE STATED IN THE CONTRACT. THE MATERIALS, FABRICATION AND WORK NECESSARY TO TIE THE PIPE BY THIS DETAIL WILL BE CONSIDERED INCIDENTAL TO THE PIPE AND APRON ENDWALLS IF REQUIRED.

DETAILED DRAWINGS FOR PROPOSED ALTERNATE DESIGNS FOR JOINT TIES SHALL BE SUBMITTED TO THE ENGINEER FOR APPROVAL.

JOINT TIES TO BE HOT-DIP GALVANIZED PER ASTM A 153.

- ① CENTER LINE OF TONGUE AND GROOVE OR BELL AND SPIGOT JOINTS.
- ② THE INSIDE OF THE THREADED INSERTS SHALL BE CLEAN TO ALLOW THE INSERTION OF THREADED EYE BOLTS.
- ③ HOLES SHALL BE CAST-IN-PLACE OR DRILLED PER THE APPLICABLE DETAIL, AND EQUAL DISTANCE FROM THE CENTERLINE OF THE JOINT.
- ④ BOLT PROJECTION INSIDE OF PIPE SHALL NOT EXCEED 2 INCHES.
- ⑤ OPENING TO BE ROD DIAMETER PLUS 1 INCH.
- ⑥ LENGTH ADEQUATE TO EXTEND TO WITHIN 1/2 INCH OF THE INNER SURFACE OF THE PIPE.
- ⑦ EYE BOLT LENGTH DETERMINED BY WALL THICKNESS, BELL THICKNESS AND BOLT PROJECTION INSIDE PIPE.

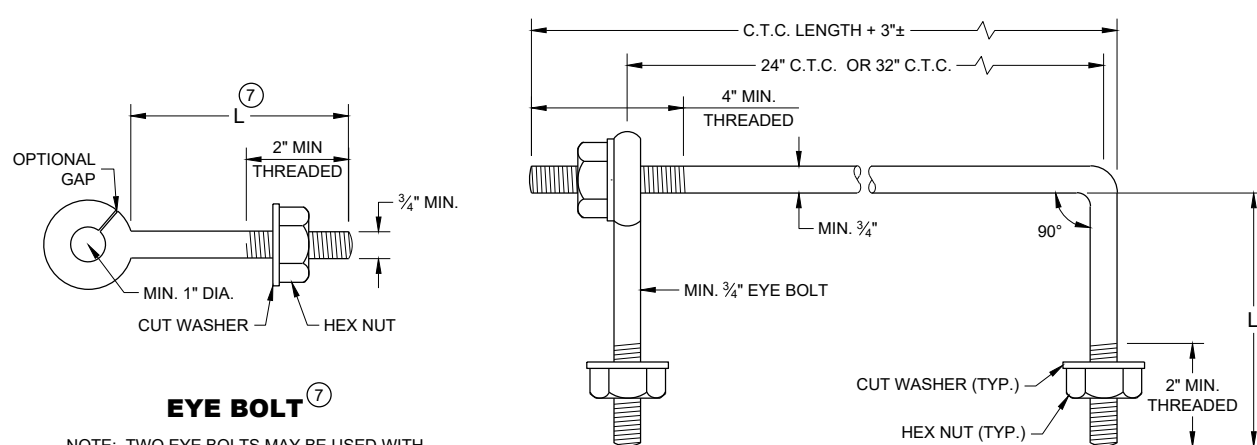

EYE BOLT AND TIE ROD

EYE BOLT ⑦

NOTE: TWO EYE BOLTS MAY BE USED WITH A 30" OR 38" LONG THREADED ROD IN LIEU OF THE 90° BENT TIE ROD.

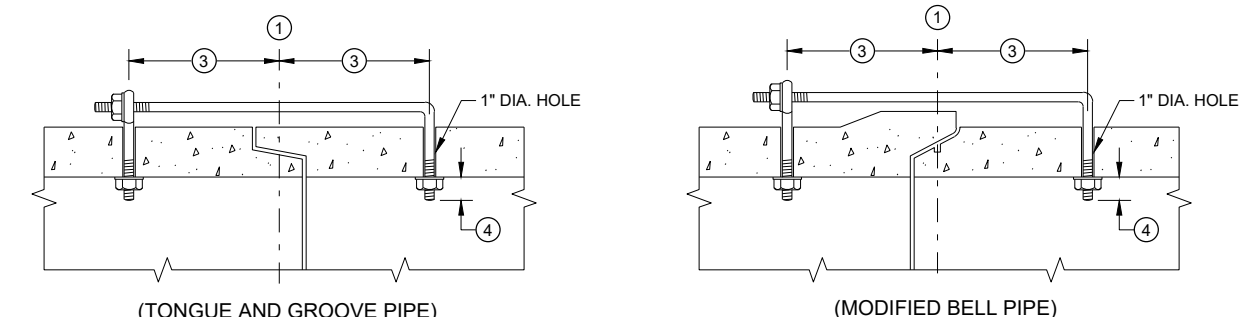

LONGITUDINAL SECTION
(JOINT TIES FOR 18" TO 66" DIA. CONCRETE PIPE)

EYE BOLT AND TIE ROD ASSEMBLY (ALTERNATE NO. 2)

ADJUSTABLE TIE ROD TABLE

PIPE DIAMETER	TIE ROD DIAMETER	D	L ₁	N
12 - 60	5/8	5/8	5	1/2
66 - 84	3/4	3/4	5	1/2
90 - 144	1	1	7	1 1/16

DIMENSIONS SHOWN ARE IN INCHES

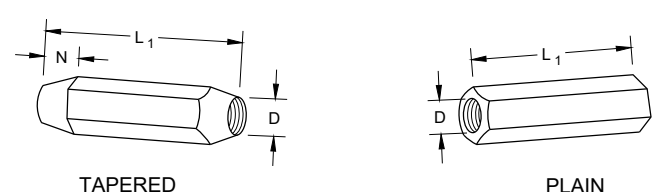

RIGHT AND LEFT THREADS SLEEVE NUTS

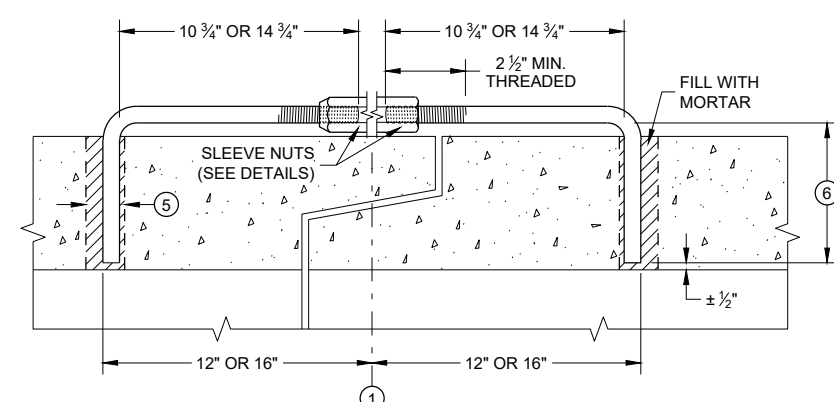

LONGITUDINAL SECTION

ADJUSTABLE TIE ROD (ALTERNATE NO. 3)

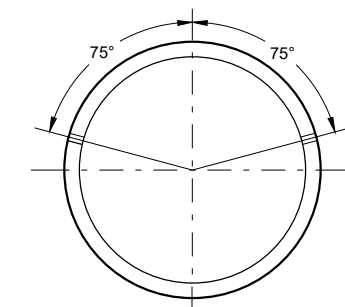

PLACEMENT OF (2) CAST-IN-PLACE INSERTS OR HOLES DURING FABRICATION FOR PIPE SECTIONS REQUIRING TIE RODS

TRANSVERSE SECTION

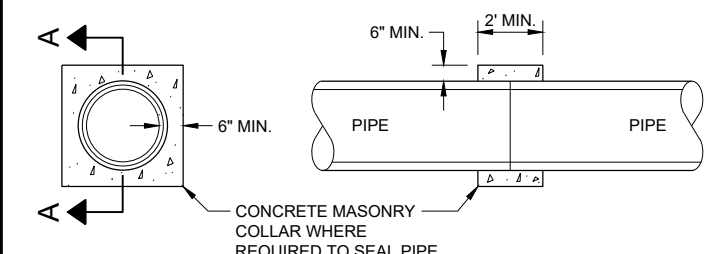

SECTION A - A
CONCRETE COLLAR DETAIL

JOINT TIES FO CONCRETE PIPE AND CONCRETE COLLAR DETAIL

STATE OF WISCONSIN
DEPARTMENT OF TRANSPORTATION

APPROVED
November 2021 /S/ Rodney Taylor
DATE ROADWAY STANDARDS DEVELOPMENT
ENGINEER

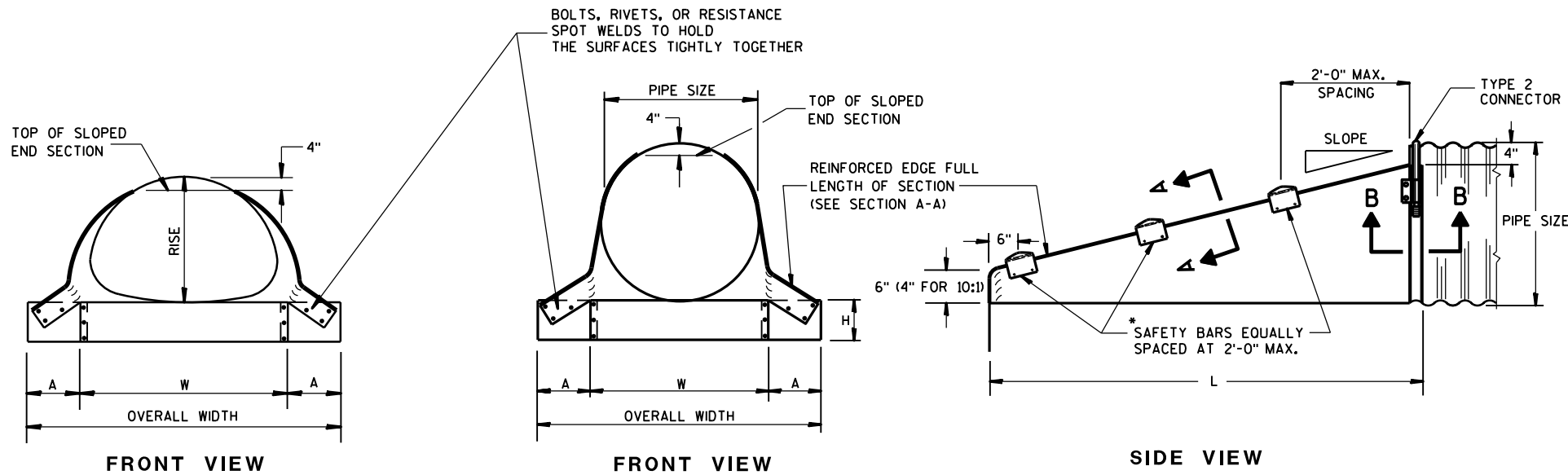

GENERAL NOTES

DETAILS OF CONSTRUCTION, MATERIALS AND WORKMANSHIP NOT SHOWN ON THIS DRAWING SHALL CONFORM TO THE PERTINENT REQUIREMENTS OF THE STANDARD SPECIFICATIONS AND THE APPLICABLE SPECIAL PROVISIONS.

SLOPED END SECTIONS SHALL CONFORM TO THE REQUIREMENTS OF THE STANDARD SPECIFICATIONS, SECTION 521 FOR STEEL APRON ENDWALLS.

SAFETY BARS SHALL BE FABRICATED FROM GALVANIZED STEEL PIPE MEETING THE REQUIREMENTS OF ASTM A-53, GRADE B, SCHEDULE 40 OR APPROVED EQUAL.

STEEL APRON ENDWALLS FOR CULVERT PIPE SLOPED SIDE DRAINS

PIPE DIA. (IN.)	MIN. THICK. (Inches)	DIMENSIONS (Inches)				L DIMENSIONS					
		A	H	W	OVERALL WIDTH	SLOPE	LENGTH INCHES	SLOPE	LENGTH INCHES	SLOPE	LENGTH INCHES
15	.064	8	6	21	37	4:1	20	6:1	30	10:1	70
18	.064	8	6	24	40	4:1	32	6:1	48	10:1	100
21	.064	8	6	27	43	4:1	44	6:1	66	10:1	130
24	.064	8	6	30	46	4:1	56	6:1	84	10:1	160
30	.109	12	9	36	60	4:1	80	6:1	120	10:1	220
36	.109	12	9	42	66	4:1	104	6:1	156	10:1	280
42	.109	16	12	48	80	4:1	128	6:1	192	—	—
48	.109	16	12	54	86	4:1	152	6:1	228	—	—
54	.109	16	12	60	92	4:1	176	6:1	264	—	—
60	.109	16	12	66	98	4:1	200	6:1	300	—	—

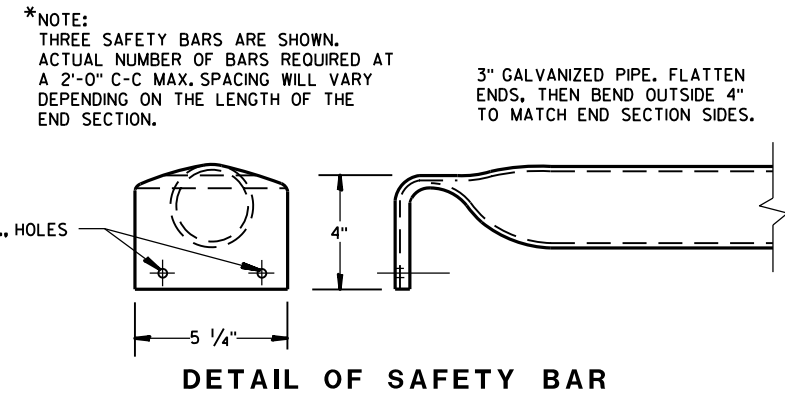
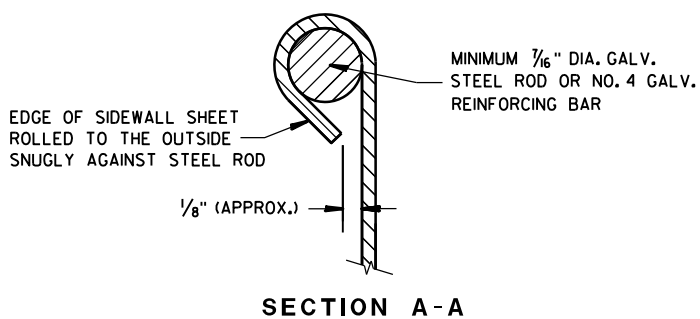

STEEL APRON ENDWALLS FOR PIPE ARCH SLOPED SIDE DRAINS

EQUIV. DIA. (Inches)	(Inches)		MIN. THICK. (Inches)	DIMENSIONS (Inches)				L DIMENSIONS					
	SPAN	RISE		A	H	W	OVERALL WIDTH	SLOPE	LENGTH INCHES	SLOPE	LENGTH INCHES	SLOPE	LENGTH INCHES
15	17	13	.064 *	7	6	30	44	4:1	19	6:1	30	10:1 ②	70
18	21	15	.064 *	8	6	27	43	4:1	20	6:1	30	10:1	70
21	24	18	.064 *	8	6	30	46	4:1	32	6:1	48	10:1	100
24	28	20	.064 *	8	6	34	50	4:1	40	6:1	60	10:1	120
30	35	24	.079 *	12	9	41	65	4:1	56	6:1	84	10:1	160
36	42	29	.109 *	12	9	48	72	4:1	76	6:1	114	10:1	210
42	49	33	.109	16	12	55	87	4:1	92	6:1	138	—	—
48	57	38	.109	16	12	63	95	4:1	112	6:1	168	—	—
54	64	43	.109	16	12	70	102	4:1	132	6:1	198	—	—

① * MINIMUM THICKNESS OF ALL 10:1 SLOPED SIDE DRAINS IS 0.109".
 ② ACTUAL SLOPE GREATER THAN 10:1.

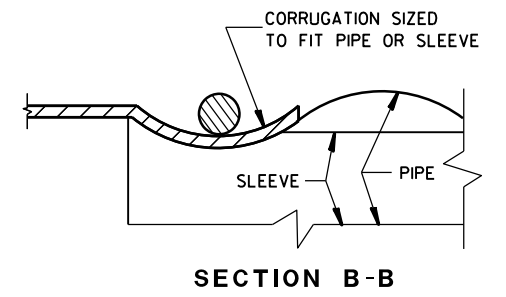
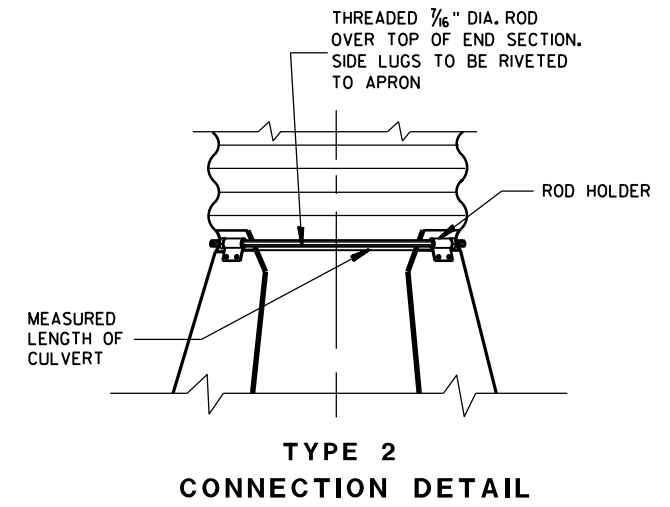
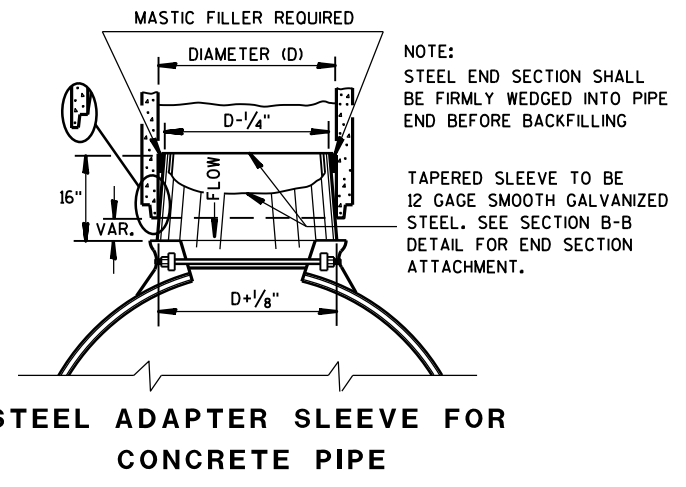
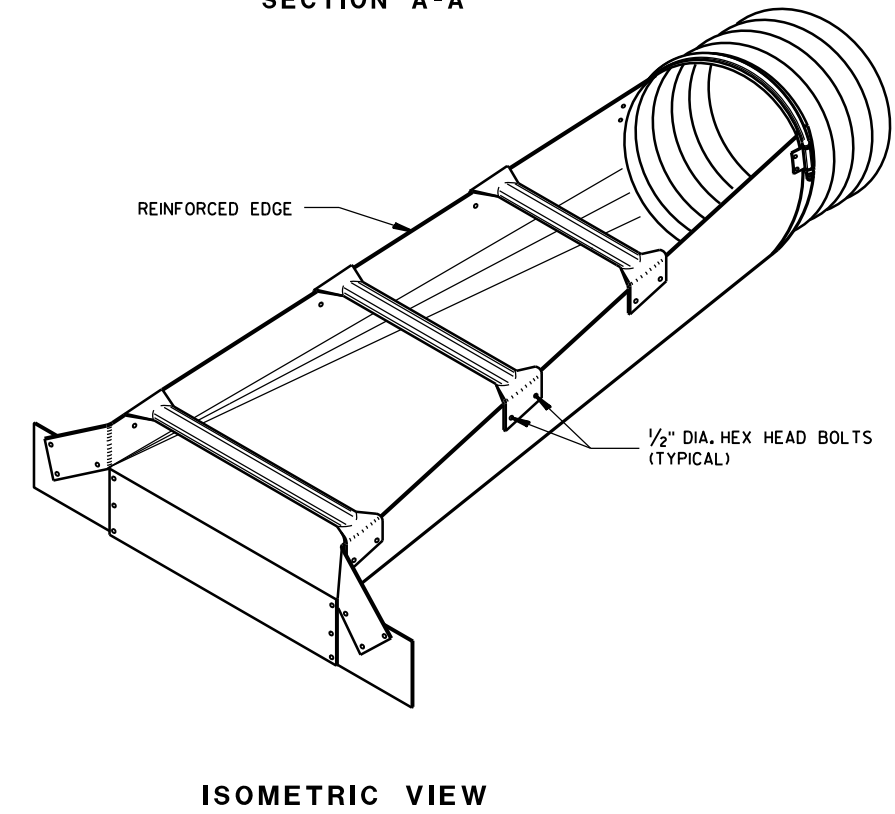

STEEL APRON ENDWALLS FOR CULVERT PIPE AND PIPE ARCH SLOPED SIDE DRAINS

STATE OF WISCONSIN
DEPARTMENT OF TRANSPORTATION

APPROVED
DATE 9/14/2012 /S/ Jerry H. Zogg
ROADWAY STANDARDS DEVELOPMENT ENGINEER

FHWA

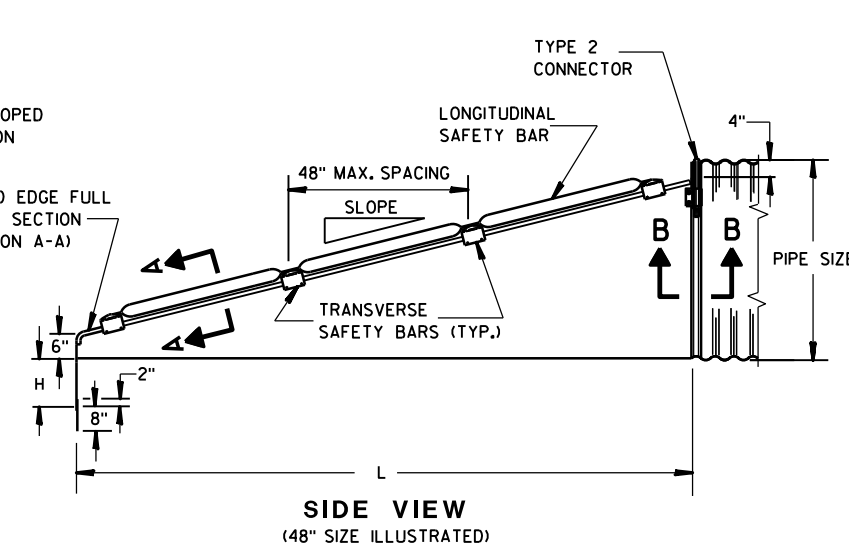
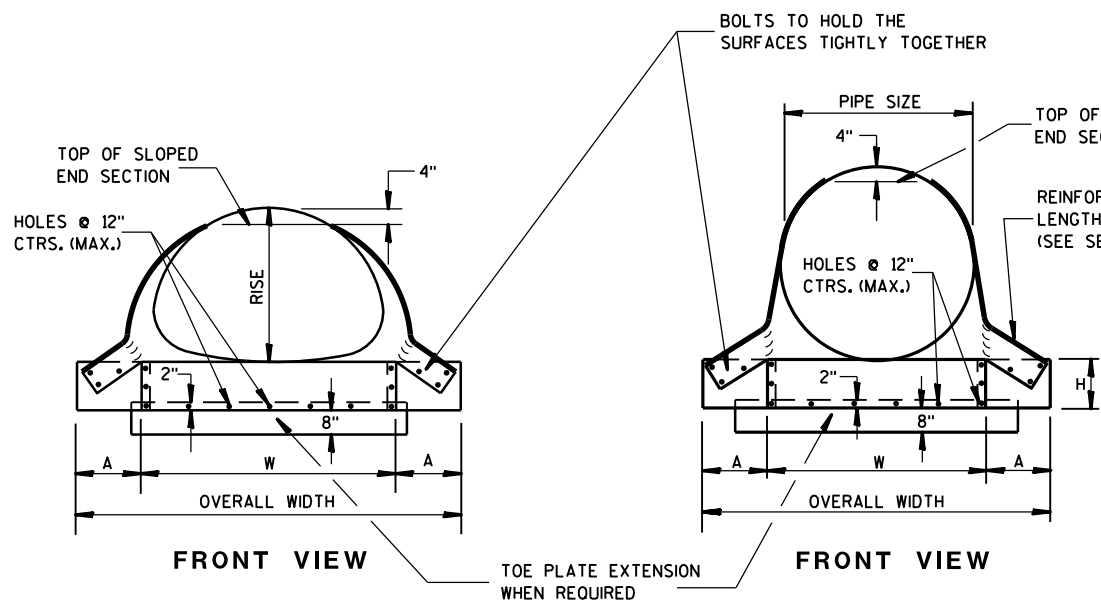

GENERAL NOTES

DETAILS OF CONSTRUCTION, MATERIALS AND WORKMANSHIP NOT SHOWN ON THIS DRAWING SHALL CONFORM TO THE PERTINENT REQUIREMENTS OF THE STANDARD SPECIFICATIONS AND APPLICABLE SPECIAL PROVISIONS.

SAFETY GRATES SHALL BE FABRICATED FROM 3-INCH DIAMETER GALVANIZED PIPE MEETING THE REQUIREMENTS OF ASTM A-53, GRADE B, SCHEDULE 40 OR APPROVED EQUAL. THE LONGITUDINAL BAR SHALL BE WELDED TO THE TRANSVERSE BARS WHERE THE BARS CROSS. THE NUMBER OF TRANSVERSE BARS REQUIRED WILL VARY DEPENDING ON THE LENGTH OF THE END SECTION.

SLOPED STEEL ENDWALLS LOCATED AT THE ENDS OF CONCRETE CULVERT PIPE SHALL BE FURNISHED WITH STEEL ADAPTER SLEEVES.

STEEL APRON ENDWALLS FOR CULVERT PIPE CROSS DRAINS										
PIPE DIA. (IN.)	MIN. THICK. IN.	GAGE	DIMENSIONS (inches)				L DIMENSIONS			
			A	H	W	OVERALL WIDTH	SLOPE	LENGTH INCHES	SLOPE	LENGTH INCHES
36	.109	12	12	9	42	66	4:1	104	6:1	156
42	.109	12	16	12	48	80	4:1	128	6:1	192
48	.109	12	16	12	54	86	4:1	152	6:1	228
54	.109	12	16	12	60	92	4:1	176	6:1	264
60	.109	12	16	12	66	98	4:1	200	6:1	300

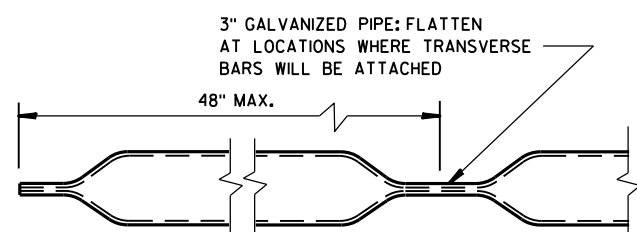
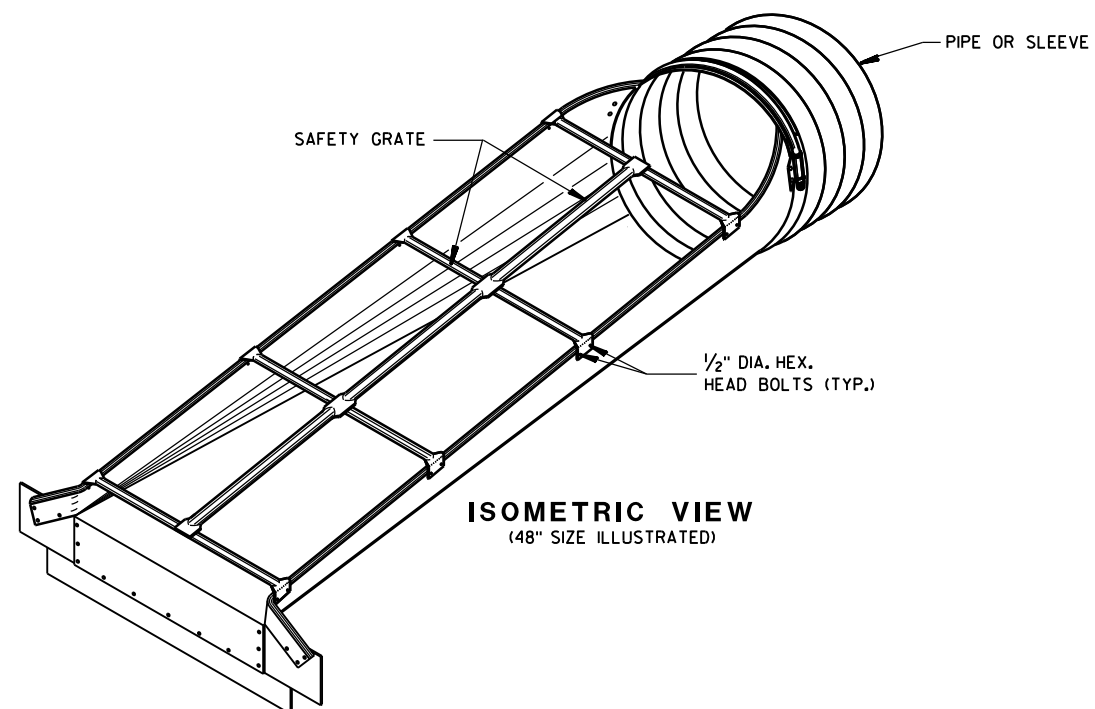

LONGITUDINAL SAFETY BAR

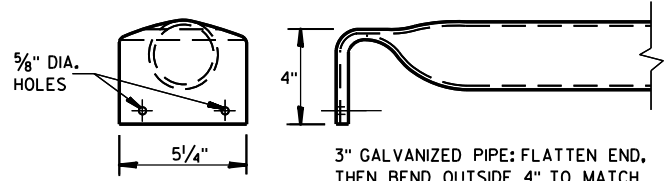

TRANSVERSE SAFETY BAR

STEEL APRON ENDWALLS FOR PIPE ARCH SLOPED CROSS DRAINS												
EQUIV. DIA. (IN.)	INCHES		MIN. THICK. IN.	GAGE	DIMENSIONS (inches)				L DIMENSIONS			
	SPAN	RISE			A	H	W	OVERALL WIDTH	SLOPE	LENGTH INCHES	SLOPE	LENGTH INCHES
30	35	24	.079	14	12	9	41	65	4:1	56	6:1	84
36	42	29	.109	12	12	9	48	72	4:1	76	6:1	114
42	49	33	.109	12	16	12	55	87	4:1	92	6:1	138
48	57	38	.109	12	16	12	63	95	4:1	112	6:1	168
54	64	43	.109	12	16	12	70	102	4:1	132	6:1	198
60	71	47	.109	12	16	12	77	109	4:1	148	6:1	222

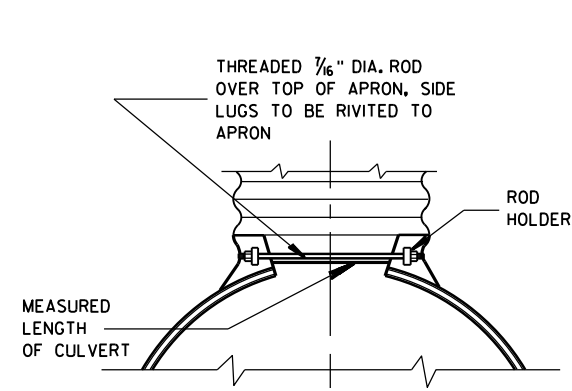

TYPE 2 CONNECTOR DETAIL

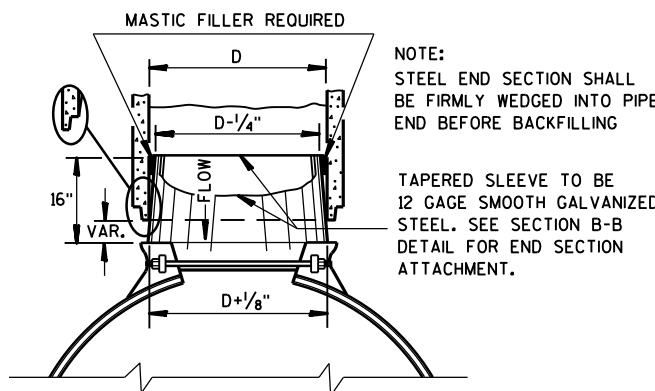

STEEL ADAPTER SLEEVE FOR CONCRETE PIPE

NOTE: STEEL END SECTION SHALL BE FIRMLY WEDGED INTO PIPE END BEFORE BACKFILLING

TAPERED SLEEVE TO BE 12 GAGE SMOOTH GALVANIZED STEEL. SEE SECTION B-B DETAIL FOR END SECTION ATTACHMENT.

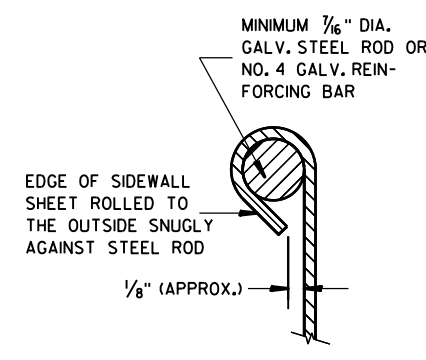

SECTION A-A

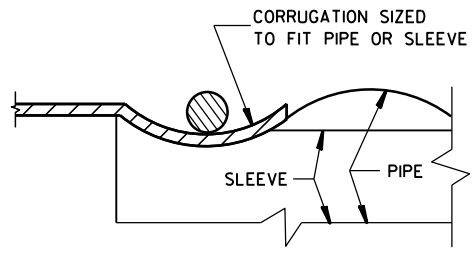

SECTION B-B

STEEL APRON ENDWALLS FOR CULVERT PIPE AND PIPE ARCH SLOPED CROSS DRAINS

STATE OF WISCONSIN
DEPARTMENT OF TRANSPORTATION

APPROVED
DATE 6/5/2012 /S/ Jerry H. Zogg
ROADWAY STANDARDS DEVELOPMENT ENGINEER

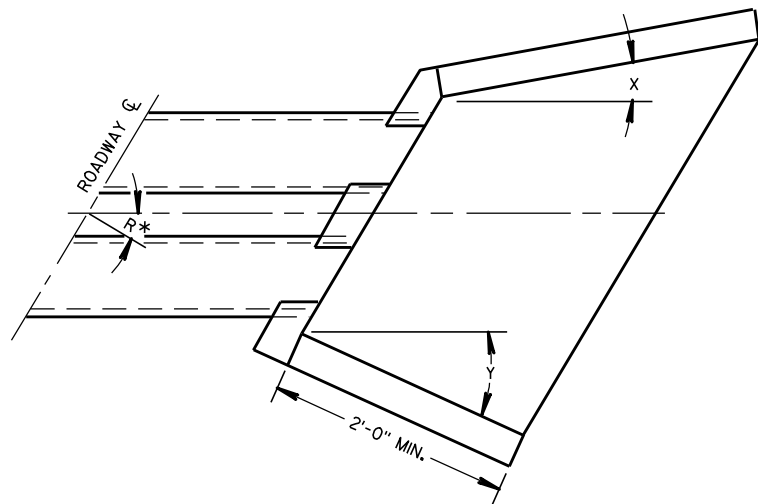

WINGWALL ANGLE DETAILS

INLET			OUTLET		
R*	X	Y	R*	X	Y
0 - 7°	30°	30°	0 - 15°	15°	15°
8 - 22°	25°	"	16 - 45°	10°	"
23 - 37°	20°	"	46 - 75°	5°	"
38 - 52°	15°	"	OVER 75°	0°	"
53 - 67°	10°	"			
68 - 82°	5°	"			
OVER 82°	0°	"			

*R = NUMBER OF DEGREES RIGHT OR LEFT HAND FORWARD

GENERAL NOTES

DETAILS OF CONSTRUCTION, MATERIALS AND WORKMANSHIP NOT SHOWN ON THIS DRAWING SHALL CONFORM TO THE PERTINENT REQUIREMENTS OF THE STANDARD SPECIFICATIONS AND THE APPLICABLE SPECIAL PROVISIONS.

FILL SLOPES FLATTER THAN 2 1/2:1 SHALL BE WARPED TO MEET THE TOP OF THE WINGWALLS.

ALL STEEL REINFORCEMENT AND WELDED STEEL WIRE FABRIC SHALL BE EMBEDDED 2 INCHES CLEAR UNLESS OTHERWISE NOTED.

1 MINIMUM REINFORCEMENT SHALL BE 6" X 6" - W4.0 X W4.0 OR NO. 3 BARS SPACED 12" C-C IN BOTH DIRECTIONS.

2 THE SPACE BETWEEN PIPES SHALL BE AS FOLLOWS:

DIAMETER OR SPAN	SPACE
UP TO AND INCLUDING 48"	2'-0"
OVER 48" TO 72"	1/2 DIA. OR SPAN
OVER 72"	3'-0"

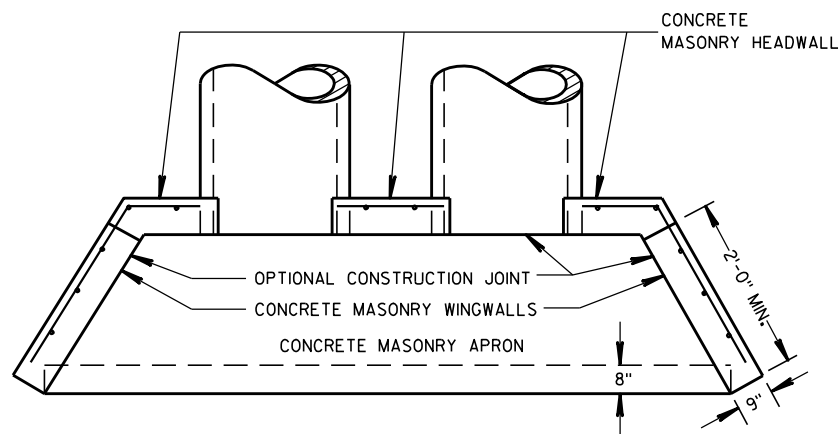

**PLAN VIEW
CULVERT PIPE AND PIPE ARCH**

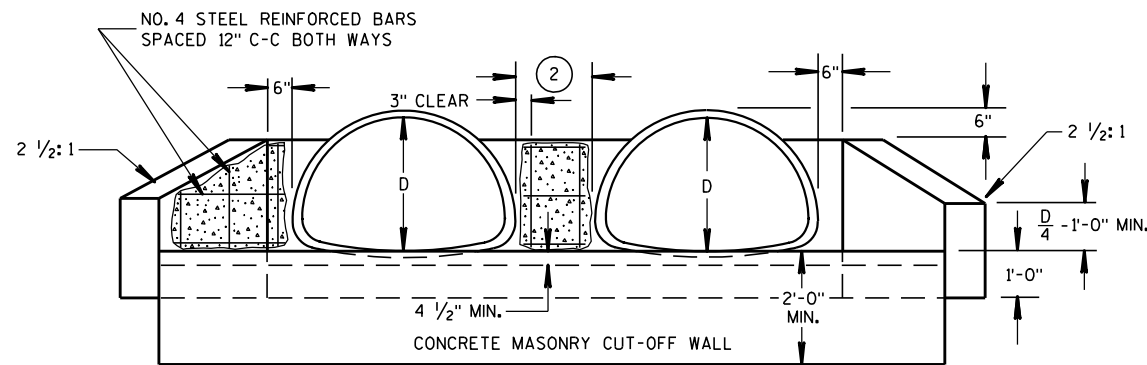

**END ELEVATION
PIPE ARCH**

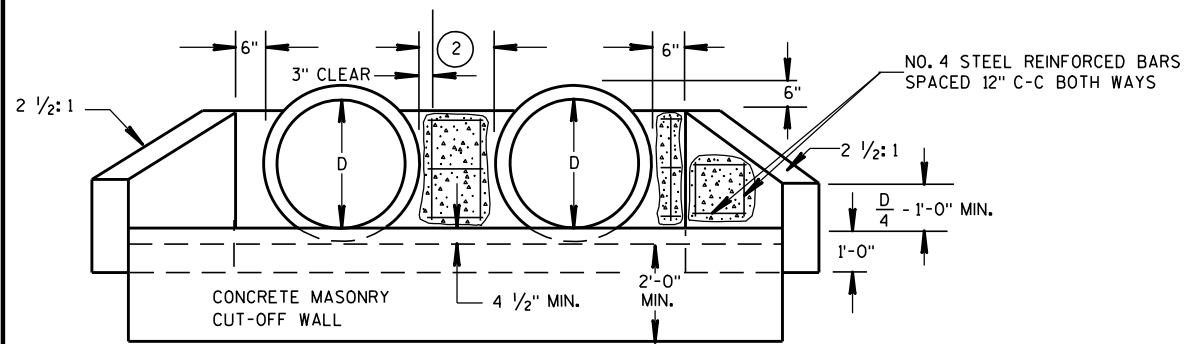

**END ELEVATION
CULVERT PIPE**

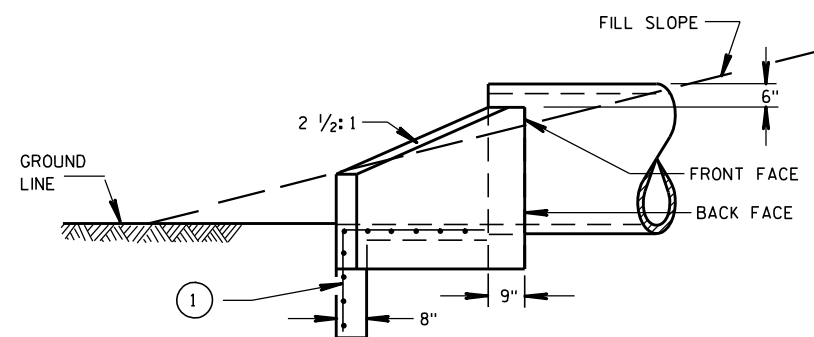

**SIDE ELEVATION
CULVERT PIPE AND PIPE ARCH**

6

6

S.D.D. 8 F 10-1

S.D.D. 8 F 10-1

**CONCRETE MASONRY ENDWALLS
FOR CULVERT PIPE AND
PIPE ARCH**

STATE OF WISCONSIN
DEPARTMENT OF TRANSPORTATION

APPROVED
9/14/98 /S/ Rory L. Rhinesmith
DATE CHIEF ROADWAY DEVELOPMENT ENGINEER
FHWA

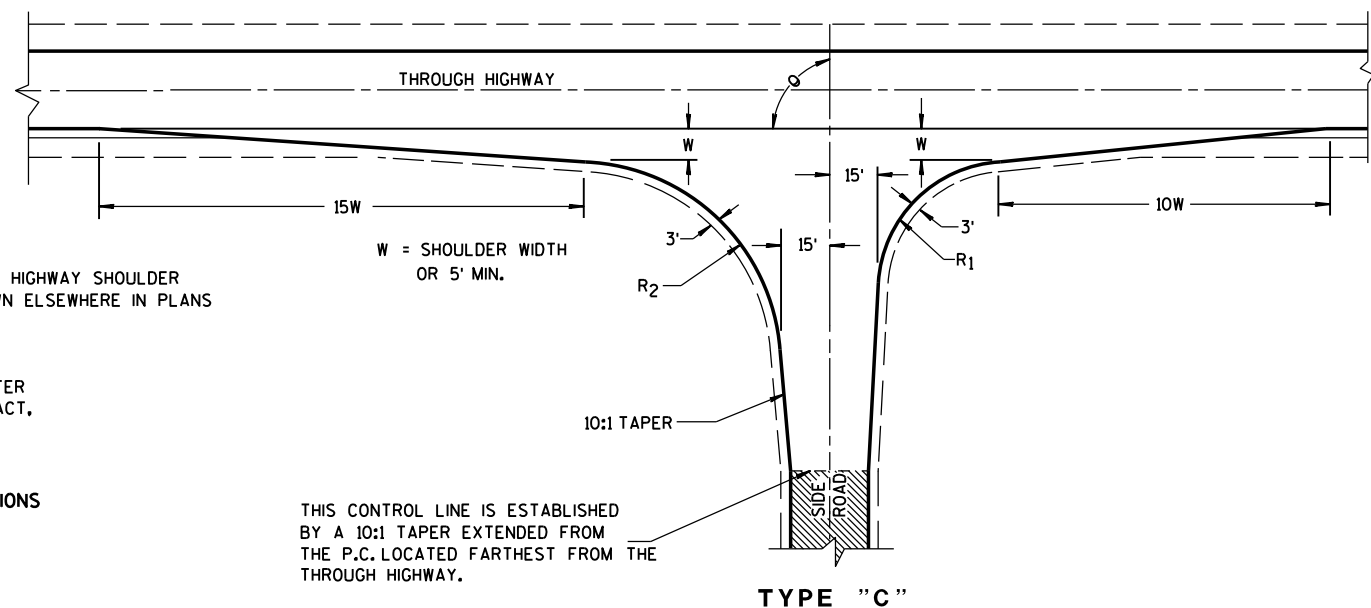
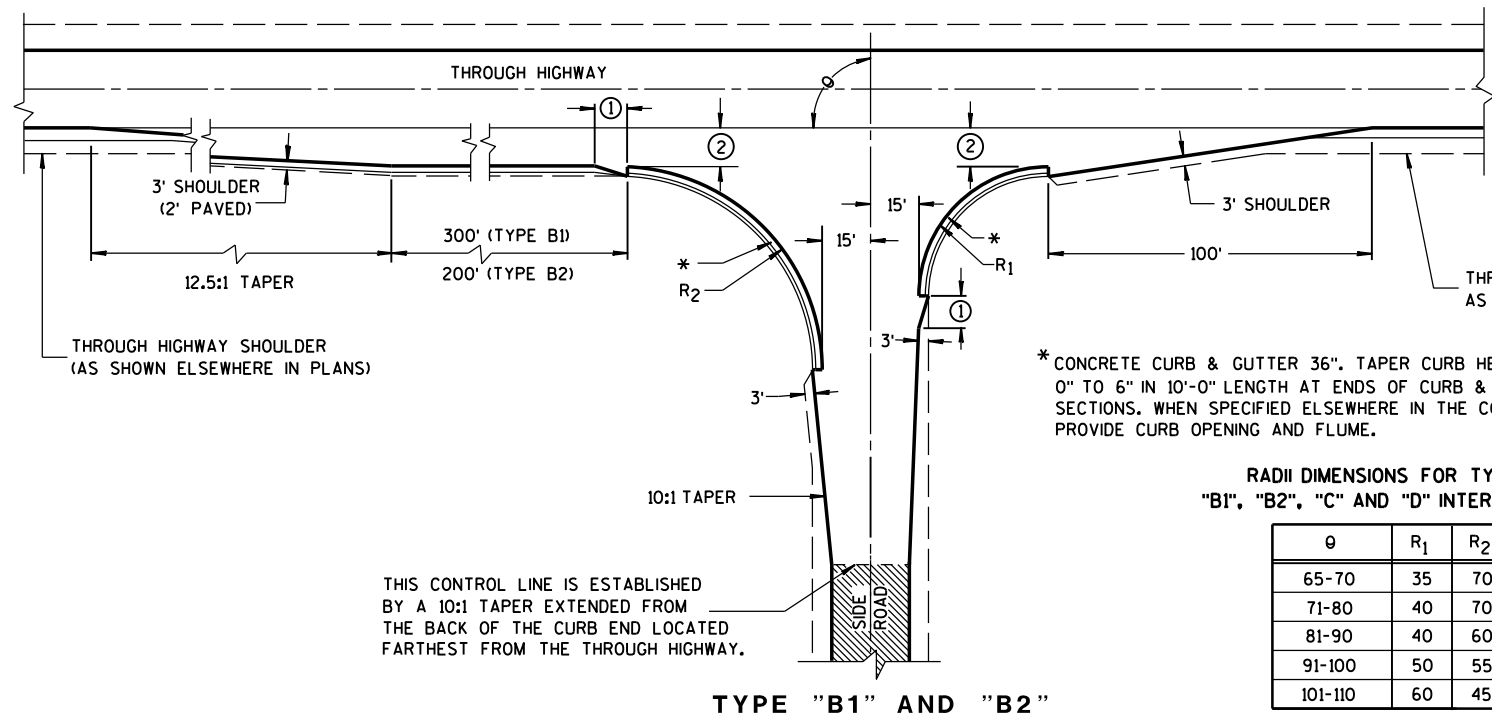

RADII DIMENSIONS FOR TYPES "B1", "B2", "C" AND "D" INTERSECTIONS

θ	R ₁	R ₂
65-70	35	70
71-80	40	70
81-90	40	60
91-100	50	55
101-110	60	45

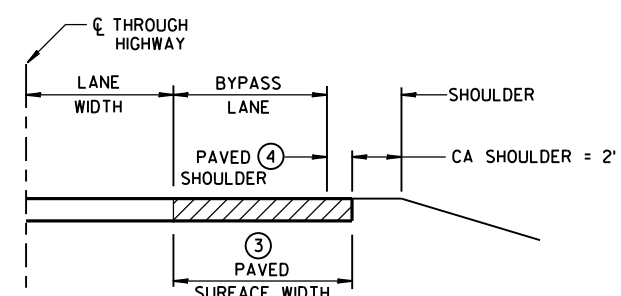
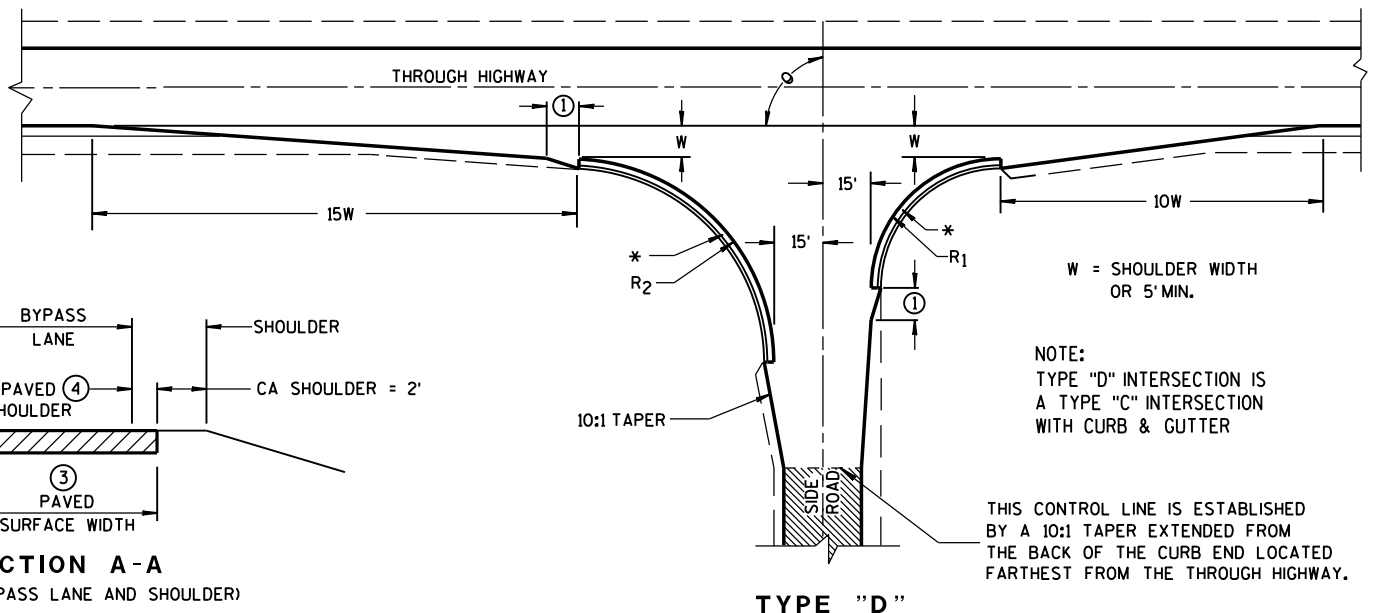

GENERAL NOTES

DESIGNS MAY BE USED INTERCHANGEABLY IN COMBINATION OR SEPARATELY FOR ANY ONE COMPLETE INTERSECTION DEPENDING UPON INTERSECTION ANGLE AND SURFACING OF EACH APPROACH ROADWAY.

SIDE ROAD SURFACING NOTE

WHEN THE SIDE ROAD IS NOT PRESENTLY PAVED, PAVEMENT SHALL BE PLACED TO THE LIMITS SHOWN UNLESS OTHERWISE PROVIDED IN THE CONTRACT. WHERE THE CONSTRUCTION LIMITS ARE BEYOND THE PAVING LIMITS, CRUSHED AGGREGATE SURFACING SHALL BE PLACED BETWEEN THE PAVING LIMITS AND CONSTRUCTION LIMITS.

WHEN THE SIDE ROAD IS PRESENTLY PAVED, NEW PAVEMENT SHALL BE PLACED TO THE LIMITS OF DESIGN AS SHOWN AND BEYOND, IF NECESSARY, TO MEET EXISTING PAVEMENT.

WHEN THE SIDE ROAD IS THE CONSTRUCTION PROJECT, THE INTERSECTION SURFACING SHALL BE THE SAME AS FOR THE PROJECT.

EXISTING PAVED SURFACE

BYPASS LANE

- ① 10-FT TYPICAL.
- ② 12-FT** PLUS ADDITIONAL WIDTH FOR BIKE LANE IF SHOWN ELSEWHERE IN THE PLAN.
**10-FT MAY BE USED ON TYPE B2 ON RESURFACING PROJECTS IF SPECIFIED IN THE CONTRACT.
- ③ BYPASS LANE PAVED SURFACE WIDTH OUTSIDE OF TRAVEL LANE
-ASPHALT = 12-FT PLUS PAVED SHOULDER WIDTH.
-PC CPNCRETE = 13-FT PLUS PAVED SHOULDER WIDTH.
- ④ BYPASS LANE PAVED SHOULDER WIDTH = THE GREATER OF 1-FT OR THE PAVED SHOULDER WIDTH OF THE THROUGH HIGHWAY.

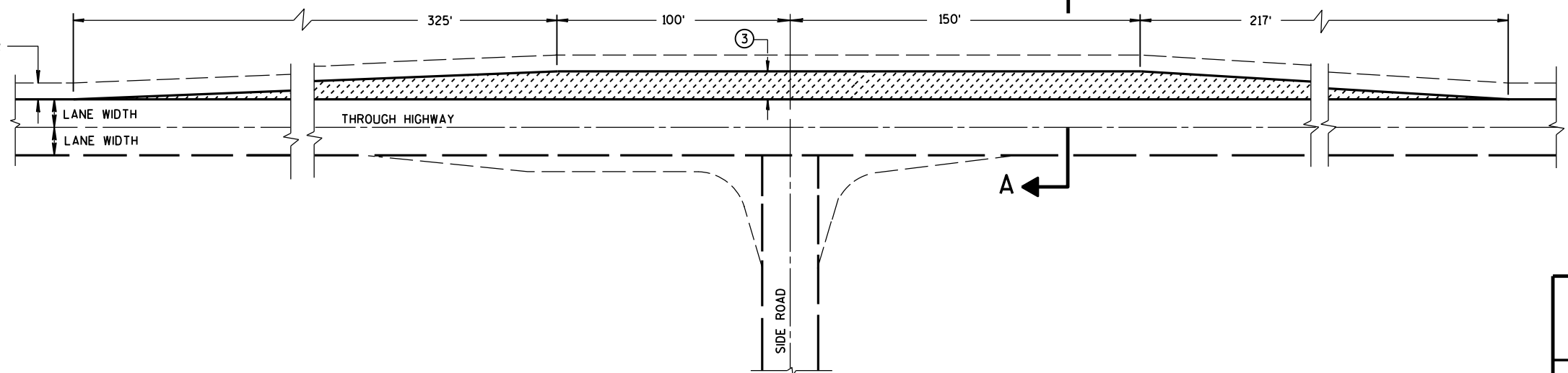

AT-GRADE SIDE ROAD INTERSECTION, TYPES "B1", "B2", "C" AND "D" AND TEE INTERSECTION BYPASS LANE

STATE OF WISCONSIN DEPARTMENT OF TRANSPORTATION

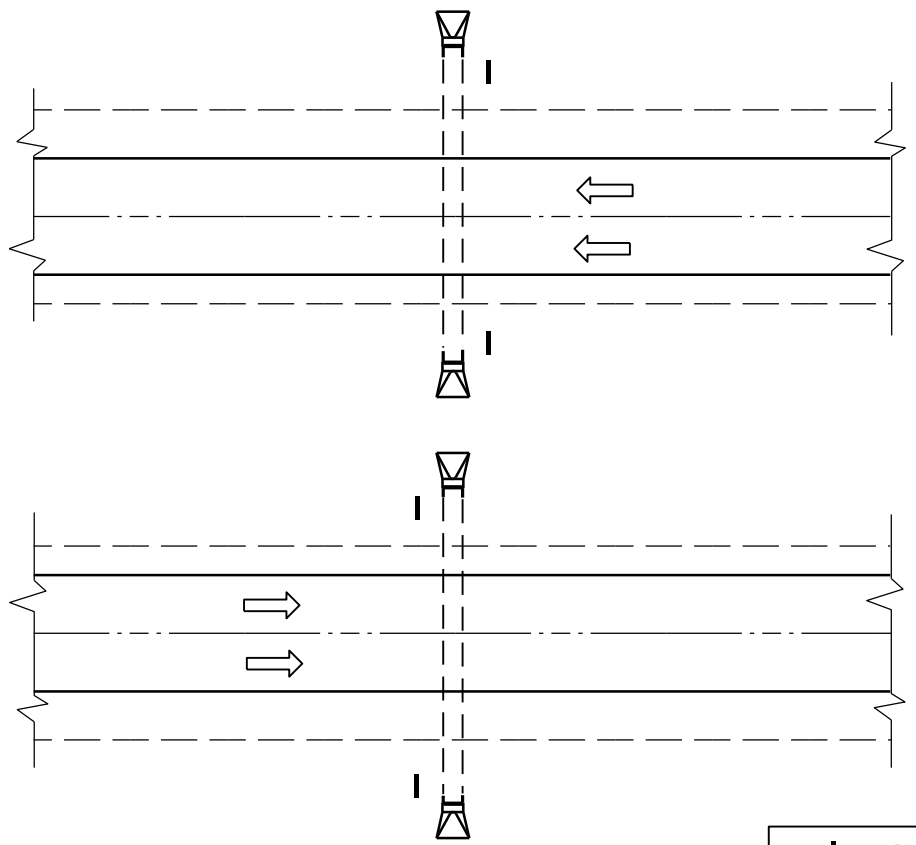

PLAN VIEW
DIVIDED HIGHWAY

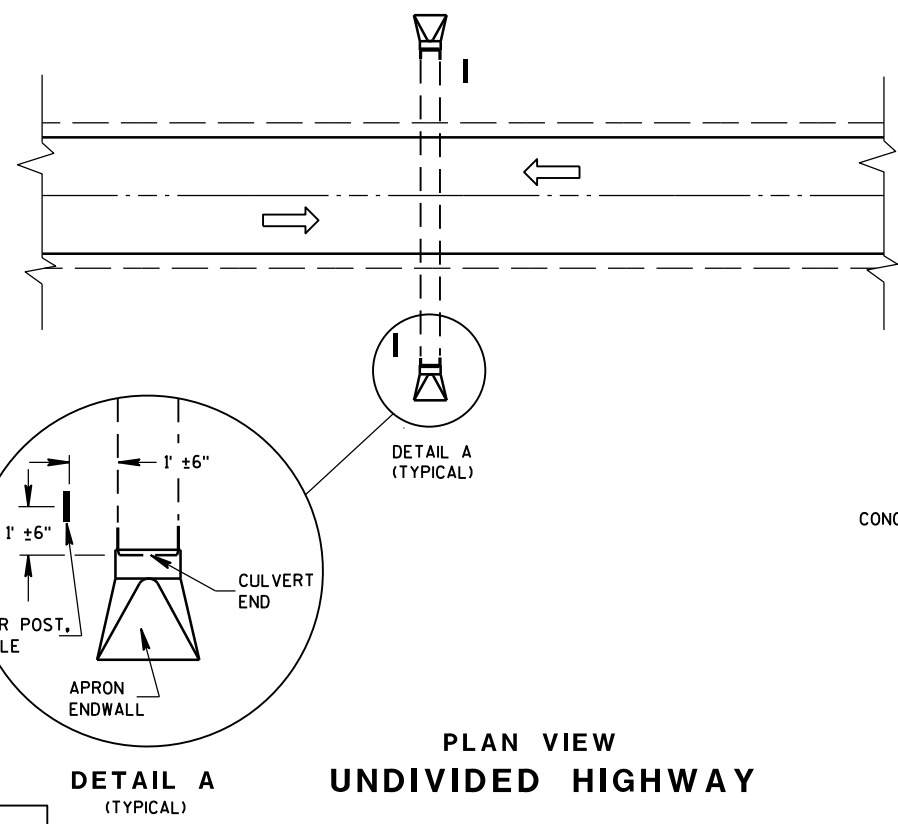

PLAN VIEW
UNDIVIDED HIGHWAY

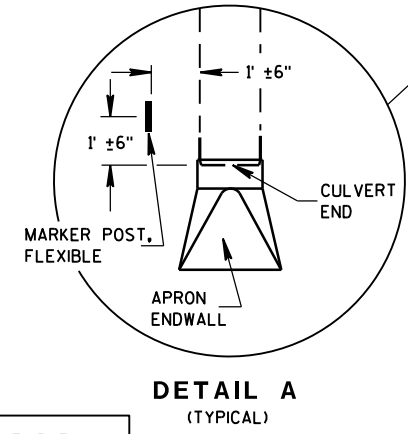

DETAIL A
(TYPICAL)

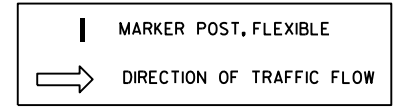

FLEXIBLE MARKER POST LOCATION

GENERAL NOTES

DETAILS OF CONSTRUCTION, MATERIALS AND WORKMANSHIP NOT SHOWN ON THIS DRAWING SHALL CONFORM TO THE PERTINENT REQUIREMENTS OF THE STANDARD SPECIFICATIONS AND THE APPLICABLE SPECIAL PROVISIONS.

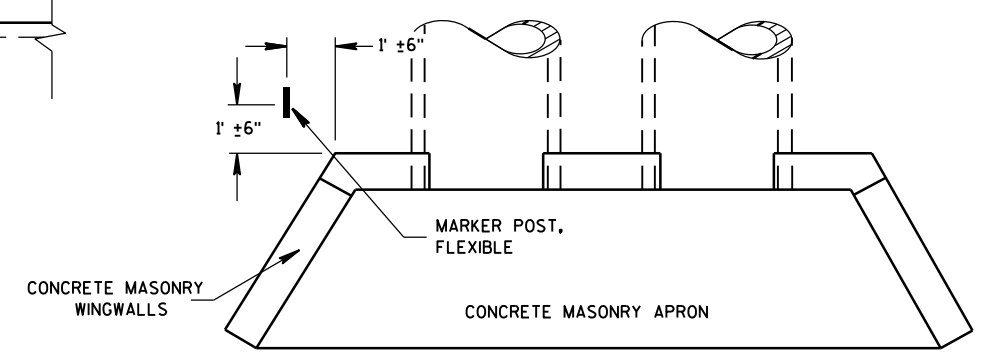

PLAN VIEW
CONCRETE MASONRY ENDWALLS FOR
CULVERT PIPE AND PIPE ARCH

6

6

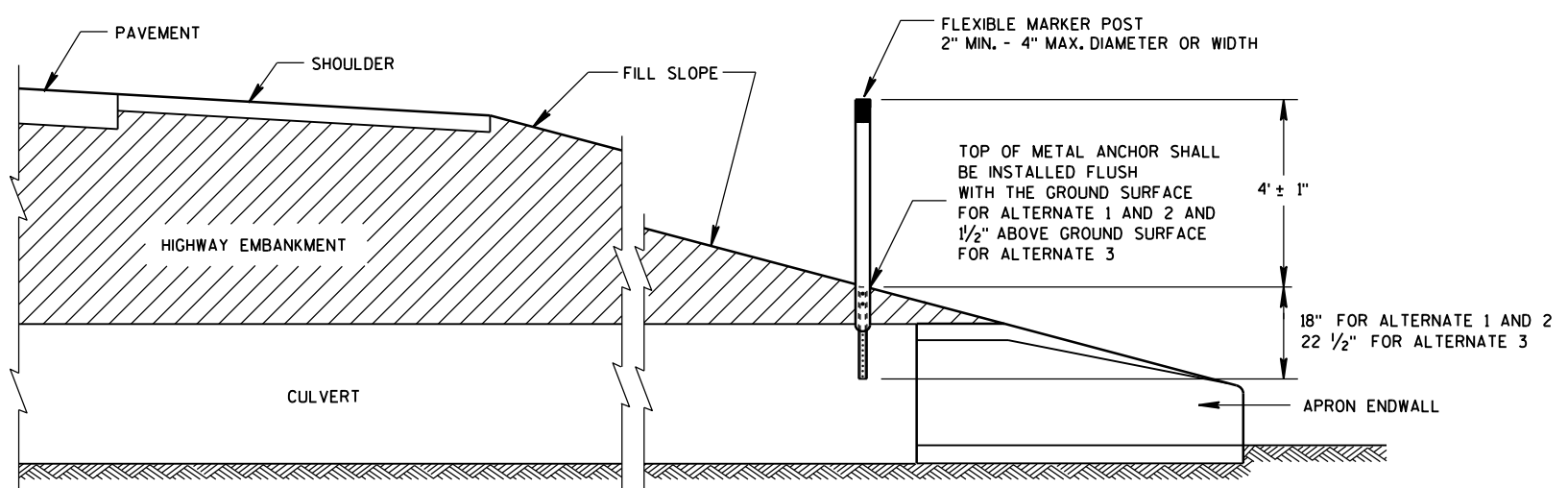

CROSS SECTION
FLEXIBLE MARKER POST

FLEXIBLE MARKER POST
FOR CULVERT END

STATE OF WISCONSIN
DEPARTMENT OF TRANSPORTATION

S.D.D. 15 A 3-2a

S.D.D. 15 A 3-2a

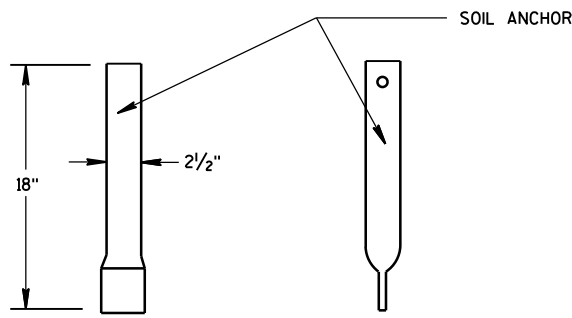
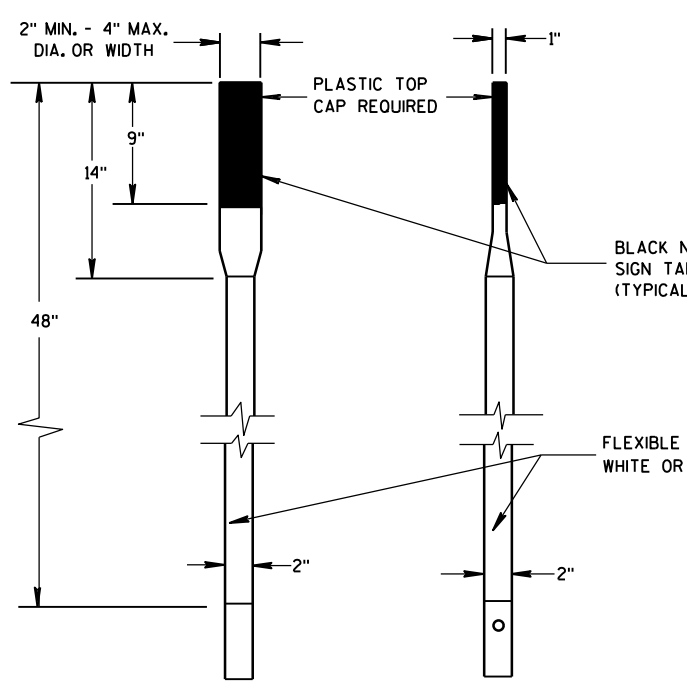

FRONT VIEW SIDE VIEW
ALTERNATE 1

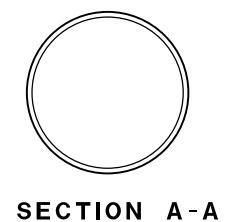

SECTION A-A

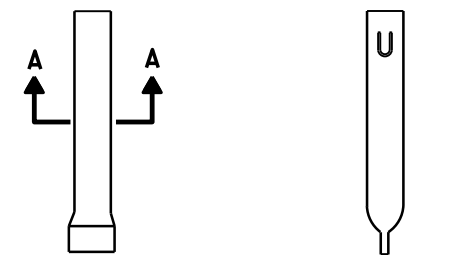

FRONT VIEW SIDE VIEW
ALTERNATE 1

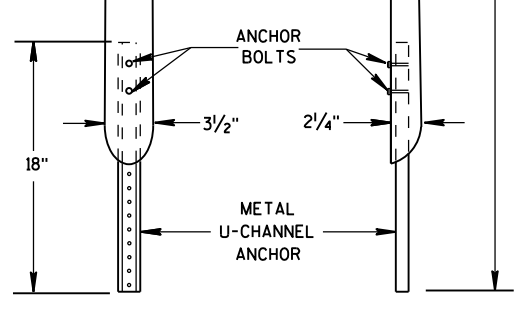
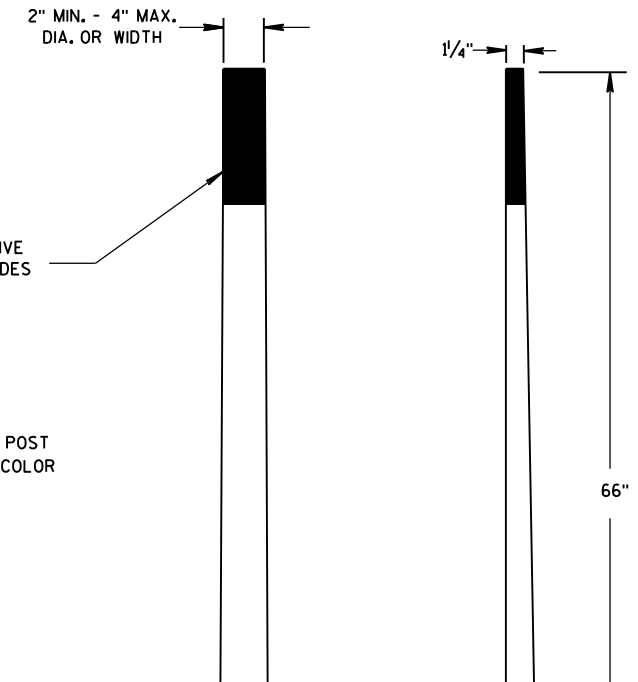

FRONT VIEW SIDE VIEW
ALTERNATE 2

FLEXIBLE MARKER POSTS

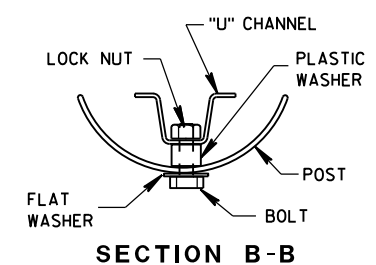

SECTION B-B

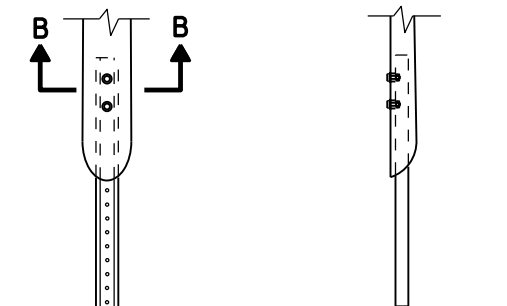

FRONT VIEW SIDE VIEW
ALTERNATE 2

FLEXIBLE MARKER POST ANCHORS

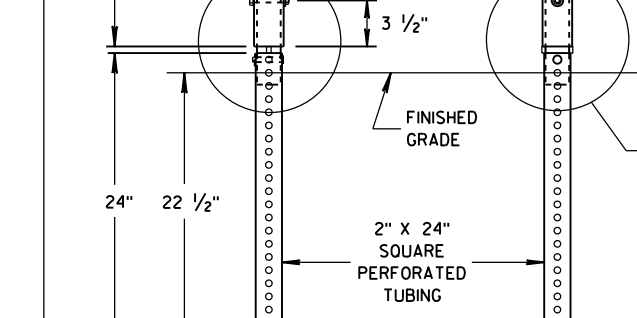
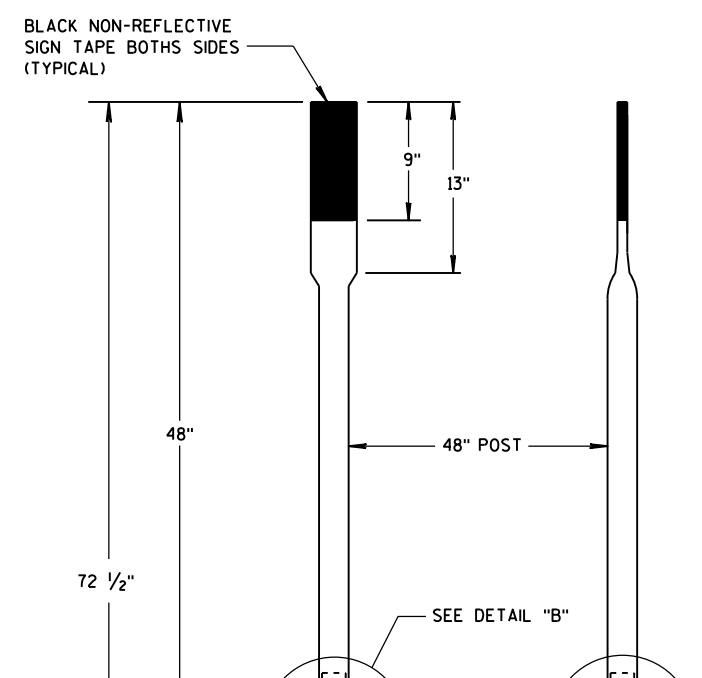

FRONT VIEW SIDE VIEW
ALTERNATE 3

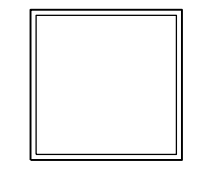

SECTION C-C

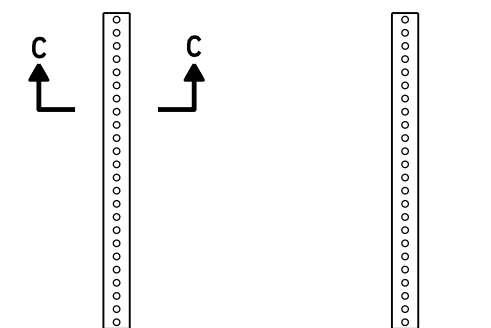

FRONT VIEW SIDE VIEW
ALTERNATE 3

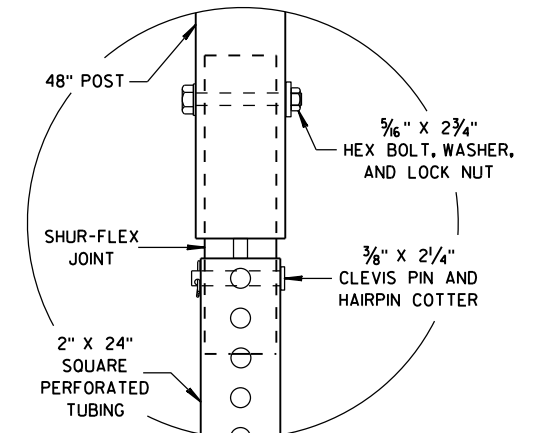

DETAIL B

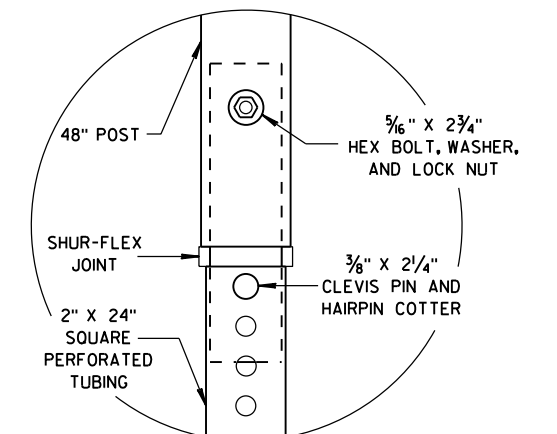

DETAIL C

FLEXIBLE MARKER POST FOR CULVERT END

STATE OF WISCONSIN
DEPARTMENT OF TRANSPORTATION

APPROVED
10/1/2012 DATE /S/ Travis Feltes
STATE TRAFFIC ENGINEER OF DESIGN
FHWA

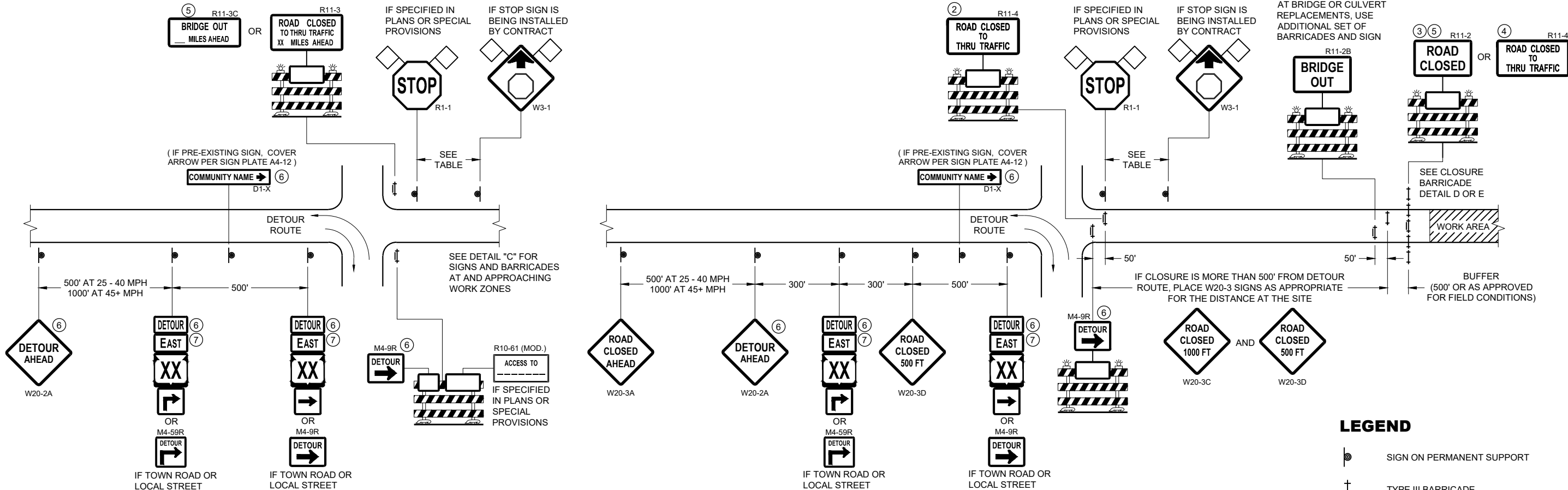

**DETAIL A
MAINLINE CLOSURE WITH POSTED DETOUR**

WORK ZONE GREATER THAN OR EQUAL TO 1/2 MILE FROM
DETOUR ROUTE (1000 FEET IF URBAN)

**DETAIL B
MAINLINE CLOSURE WITH POSTED DETOUR**

WORK ZONE LESS THAN 1/2 MILE FROM
DETOUR ROUTE (1000 FEET IF URBAN)

LEGEND

- SIGN ON PERMANENT SUPPORT
- TYPE III BARRICADE
- TYPE III BARRICADE WITH ATTACHED SIGN
- TYPE "A" WARNING LIGHT (FLASHING)
- WORK AREA
- FLAGS, 16" X 16" MIN. (ORANGE)

SPEED LIMIT (MPH)	"STOP AHEAD" ADVANCE WARNING DISTANCE (FT)
25	200
30	200
35	350
40	350
45	500
50	550
55	750

- M4 - 8
- M3 - X
- M1 - 4
- M1 - 6
- M1 - 5A
- M05 - 1
- M06 - 1

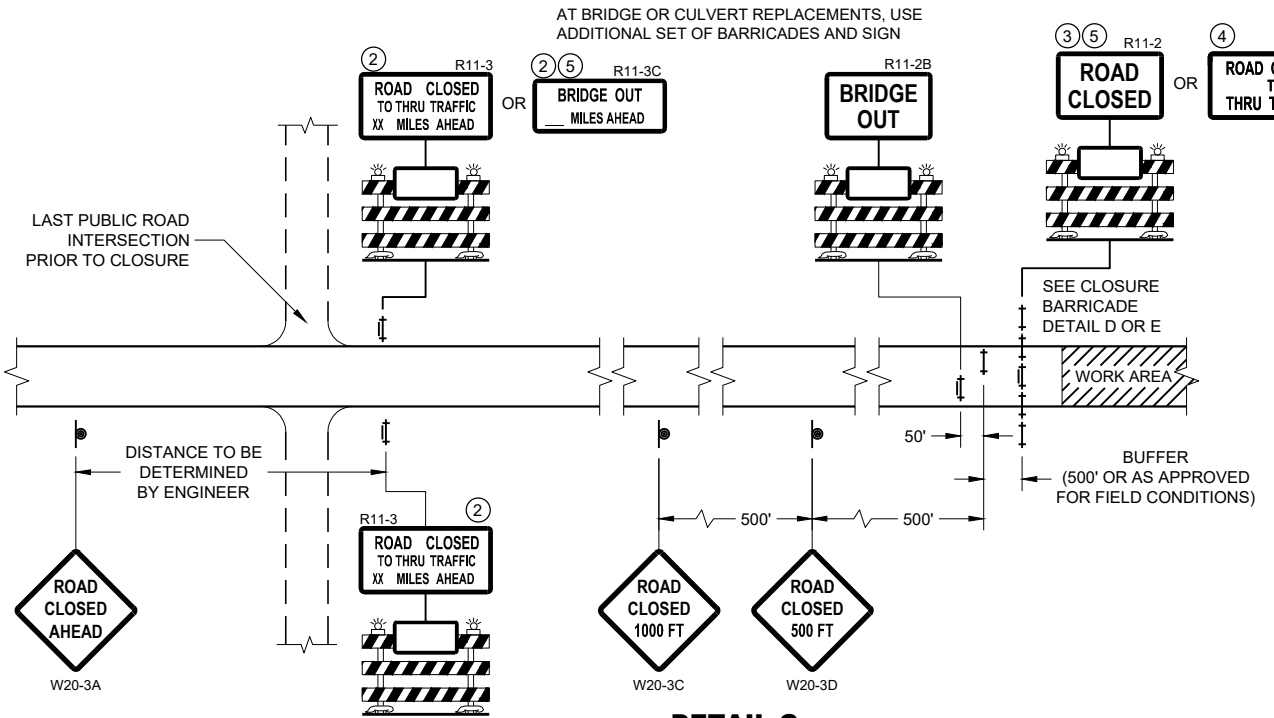

**DETAIL C
MAINLINE CLOSURE, NO POSTED DETOUR**

SEE SDD 15C2-SHEET "b"
FOR GENERAL NOTES
AND FOOTNOTES ① THROUGH ⑦

**BARRICADES AND SIGNS
FOR MAINLINE CLOSURES**

STATE OF WISCONSIN
DEPARTMENT OF TRANSPORTATION

APPROVED
February 2020 /S/ Andrew Heidtke
DATE DATE WORK ZONE ENGINEER

FHWA

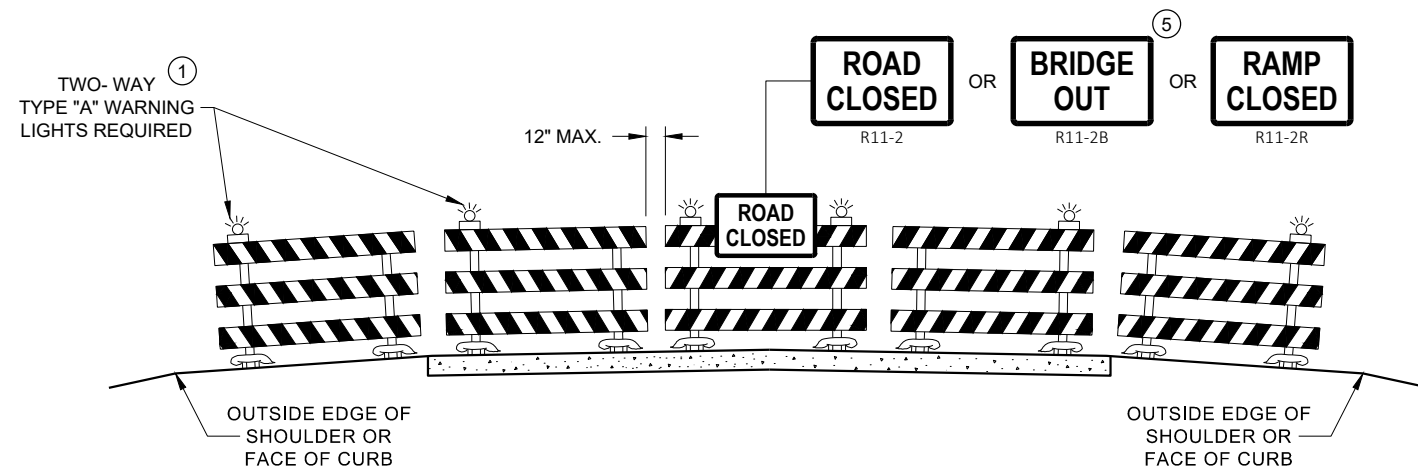

**DETAIL D
ROAD CLOSURE BARRICADE DETAIL
APPROACH VIEW**

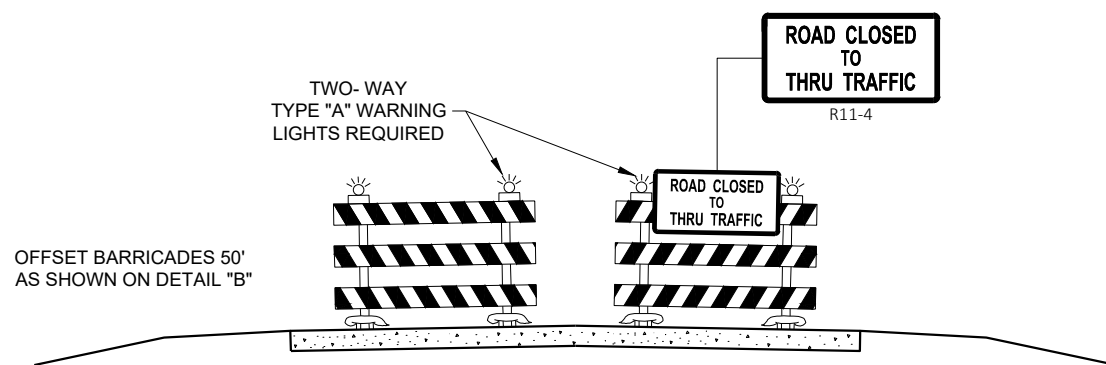

**DETAIL E
LANE CLOSURE BARRICADE DETAIL
APPROACH VIEW**

SEE SDD 15C2 - SHEET "a" FOR LEGEND

GENERAL NOTES

THE EXACT NUMBER, LOCATION, AND SPACING OF ALL SIGNS AND BARRICADES SHALL BE ADJUSTED TO FIT FIELD CONDITIONS AS APPROVED BY THE ENGINEER.

ANY SIGNS TEMPORARY OR EXISTING, WHICH CONFLICT WITH TRAFFIC CONTROL "IN USE", SHALL BE REMOVED OR COVERED AS NEEDED AND AS APPROVED BY THE ENGINEER.

THE SPACING BETWEEN TRAFFIC CONTROL SIGNS SHOULD BE ADJUSTED TO NOT CONFLICT WITH AND SHOULD PROVIDE A DESIRABLE MINIMUM OF 200 FEET CLEARANCE TO EXISTING SIGNS THAT WILL REMAIN IN PLACE.

BARRICADES THAT MUST BE MOVED FOR A WORK OPERATION SHALL BE IMMEDIATELY RE-ESTABLISHED UPON COMPLETION OF THE OPERATION, OR FOR CONTINUING OPERATIONS, AT THE END OF EACH WORKING DAY.

SIGNS THAT WILL BE IN PLACE LESS THAN 7 CONTINUOUS DAYS AND NIGHTS MAY BE MOUNTED ON PORTABLE SUPPORTS.

ALL TYPE III BARRICADES SHALL HAVE RAILS REFLECTORIZED ON BOTH FACES. STRIPES SHALL BE PROPERLY SLOPED DOWN TOWARD THE TRAFFIC SIDE OR AS SHOWN IN THE ROAD CLOSURE BARRICADE DETAIL "D" FOR FULL ROAD CLOSURES.

TYPE "A" LOW - INTENSITY FLASHING WARNING LIGHTS SHALL BE VISIBLE ON BOTH SIDES OF THE BARRICADE.

THE R11 - 2, R11 - 3, M4 - 9, R11 - 4, AND R10 - 61 SIGNS PLACED ON THE BARRICADES SHALL COVER NO MORE THAN THE TOP RAIL. THE SIGNS SHALL NOT COVER ANY PORTION OF THE MIDDLE RAIL OR BOTTOM RAILS.

"WO" AND "MO" SIGNS ARE THE SAME AS "W" AND "M" SIGNS EXCEPT THE BACKGROUND IS ORANGE.

ALL SIGNS SHALL BE 48" X 48" UNLESS OTHERWISE NOTED BELOW:

- R11 - 2 SHALL BE 48" X 30"
- R11 - 3 SHALL, R11 - 4 AND R10 - 61 SHALL BE 60" X 30"
- M4 - 9 SHALL BE 30" X 24"
- M3 - X SHALL BE 24" X 12" (36" X 18" IF NEEDED TO MATCH EXISTING SIGNS)
- M4 - 8 SHALL BE 24" X 12" (36" X 18" IF NEEDED TO MATCH EXISTING SIGNS)
- M1 - 4, M1 - 5A AND M1 - 6 SHALL BE 24" X 24" (36" X 36" IF NEEDED TO MATCH EXISTING SIGNS)
- MO5 - 1 AND MO6 - 1 SHALL BE 21" X 21" (30" X 30" IF NEEDED TO MATCH EXISTING SIGNS)
- D1 - X SHALL BE AS SHOWN ON SPECIFIC PROJECT SIGNING DETAIL SHEETS.
- R1 - 1 SHALL BE 36" X 36"

- ① TWO WARNING LIGHTS SHALL BE PROVIDED ON THE CENTER BARRICADE AND A MINIMUM OF ONE WARNING LIGHT SHALL BE PROVIDED ON EACH OF THE OTHER BARRICADES WITHIN THE ROADWAY LIMITS. SPACING OF THE WARNING LIGHTS SHALL BE UNIFORM TO THE EDGE OF ROADWAY AS SHOWN (APPROX. 8 FOOT LIGHT SPACING).
- ② THESE SIGNS AND BARRICADES ARE NOT REQUIRED IF ROAD CLOSURE BEGINS AT AN INTERSECTION.
- ③ FOR ROAD CLOSURE WITHOUT LOCAL ACCESS TO PROJECT, SEE ROAD CLOSURE BARRICADE DETAIL "D".
- ④ FOR ROAD CLOSURE WITH LOCAL ACCESS TO PROJECT, SEE ROAD CLOSURE BARRICADE DETAIL "E".
- ⑤ FOR BRIDGE OR CULVERT REPLACEMENTS, SUBSTITUTE "BRIDGE OUT" INSTEAD OF "ROAD CLOSED" ON R11 - 2 AND R11 - 3 SIGNS.
- ⑥ INSTALL DETOUR AND COMMUNITY GUIDE SIGNS AND ARROWS ONLY IF SPECIFIED IN THE CONTRACT. IF THERE ARE EXISTING ROUTE MARKER ASSEMBLIES THAT WILL REMAIN IN PLACE, ADJUST THE LOCATION OF THE DETOUR ROUTE SIGNS TO CORRESPOND WITH THE EXISTING ASSEMBLIES. MODIFY EXISTING SIGNS WHERE POSSIBLE. SEE SPECIFIC PROJECT DETOUR SIGNING DETAIL SHEETS. IF DETOUR SIGNS ARE BEING INSTALLED BY OTHERS, PLACE THE CONTRACTED TRAFFIC CONTROL SIGNS TO ALLOW FOR PLACEMENT OF ALL WARNING, DETOUR AND GUIDE SIGNS AS SHOWN.
- ⑦ "EAST" CARDINAL DIRECTION MARKERS AND RIGHT TURN ARROWS ARE SHOWN. USE OTHER CARDINAL DIRECTIONS AND ARROWS AS APPROPRIATE.

**BARRICADES AND SIGNS
FOR
VARIOUS CLOSURES**

STATE OF WISCONSIN
DEPARTMENT OF TRANSPORTATION

APPROVED
February 2020 /S/ Andrew Heidtke
DATE WORK ZONE ENGINEER
FHWA

LEGEND

- SIGN ON PERMANENT SUPPORT
- WORK AREA
- M4 - 8
- M3 - X
- M1 - 4
- M1 - 6
- M1 - 5A
- M05 - 1
- M06 - 1
- M06 - 1

GENERAL NOTES

THE EXACT NUMBER, LOCATION AND SPACING OF ALL SIGNS SHALL BE ADJUSTED TO FIT FIELD CONDITIONS AS APPROVED BY THE ENGINEER.

IF THERE ARE EXISTING ROUTE MARKER ASSEMBLIES THAT WILL REMAIN IN PLACE, ADJUST THE LOCATION OF THE DETOUR ROUTE SIGNS TO CORRESPOND WITH THE EXISTING ASSEMBLIES. SEE SPECIFIC PROJECT DETOUR SIGNING DETAIL SHEETS. MODIFY EXISTING SIGNS WHERE POSSIBLE.

THE SPACING BETWEEN TRAFFIC CONTROL AND DETOUR SIGNS SHOULD BE ADJUSTED TO NOT CONFLICT WITH AND TO PROVIDE A DESIRABLE MINIMUM OF 200 FEET CLEARANCE TO EXISTING SIGNS THAT WILL REMAIN IN PLACE.

ANY SIGNS TEMPORARY OR EXISTING, WHICH CONFLICT WITH TRAFFIC CONTROL "IN USE" SHALL BE REMOVED OR COVERED AS NEEDED AND AS APPROVED BY THE ENGINEER.

SIGNS THAT WILL BE IN PLACE LESS THAN 7 CONTINUOUS DAYS AND NIGHTS MAY BE MOUNTED ON PORTABLE SUPPORTS.

"MO" SIGNS ARE THE SAME AS "M" SIGNS EXCEPT THE BACKGROUND IS ORANGE.

SIGN SIZES SHALL BE AS FOLLOWS:

- M3-X SHALL BE 24" X 12" (36" X 18" IF NEEDED TO MATCH EXISTING SIGNS)
- M4-8 SHALL BE 24" X 12" (36" X 18" IF NEEDED TO MATCH EXISTING SIGNS)
- M1-4, M1-5A AND M1-6 SHALL BE 24" X 24" (36" X 36" IF NEEDED TO MATCH EXISTING SIGNS)
- M05-1 AND M06-1 SHALL BE 21" X 21" (30" X 30" IF NEEDED TO MATCH EXISTING SIGNS)
- M4-9 AND M4-59 SHALL BE 30" X 24"
- M4-8a SHALL BE 24" X 18"
- G20-51 SHALL BE 60" X 24"
- W20-2A SHALL BE 48" X 48"
- D1-X SHALL BE AS SHOWN ON SPECIFIC PROJECT SIGNING DETAIL SHEETS.

- * OPTIONAL SIGNS. SEE SPECIFIC PROJECT DETOUR SIGNING DETAIL SHEETS.
- ** FOR A TOWN ROAD OR LOCAL STREET DETOURED ONTO A STATE TRUNK HIGHWAY, PLACE A ROAD NAME PLAQUE ABOVE THE M4-9 SIGN AS SPECIFIED IN THE CONTRACT.

THIS DRAWING PROVIDES GENERAL GUIDANCE ON TYPICAL DETOUR SIGN LAYOUT AND SPACING. SEE PROJECT DETOUR SIGNING SHEETS FOR SPECIFIC DETAILS FOR EACH PROJECT.

MATCH POINT

DETAIL F DETOUR SIGNING

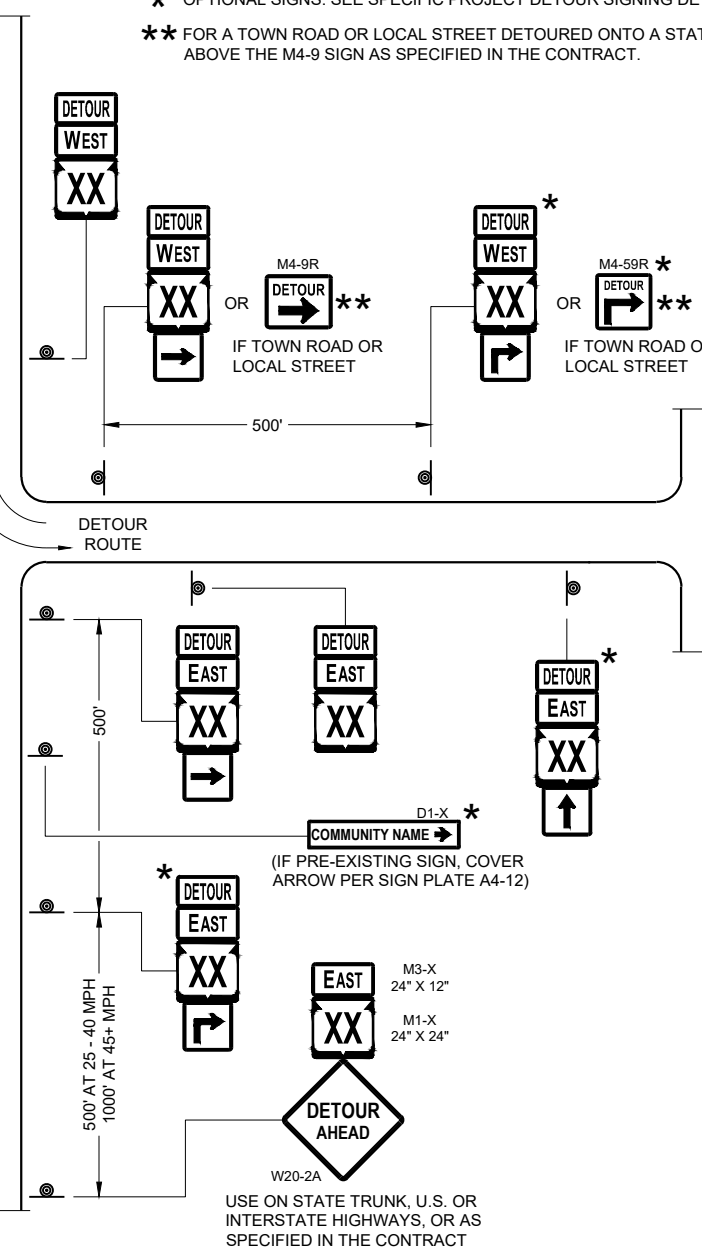
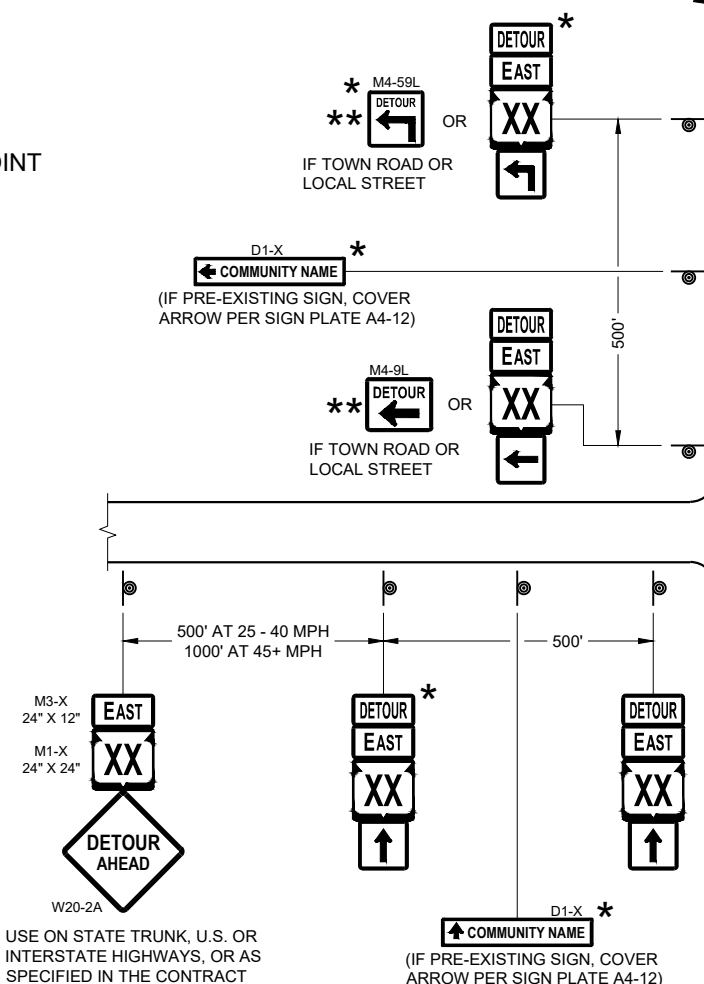
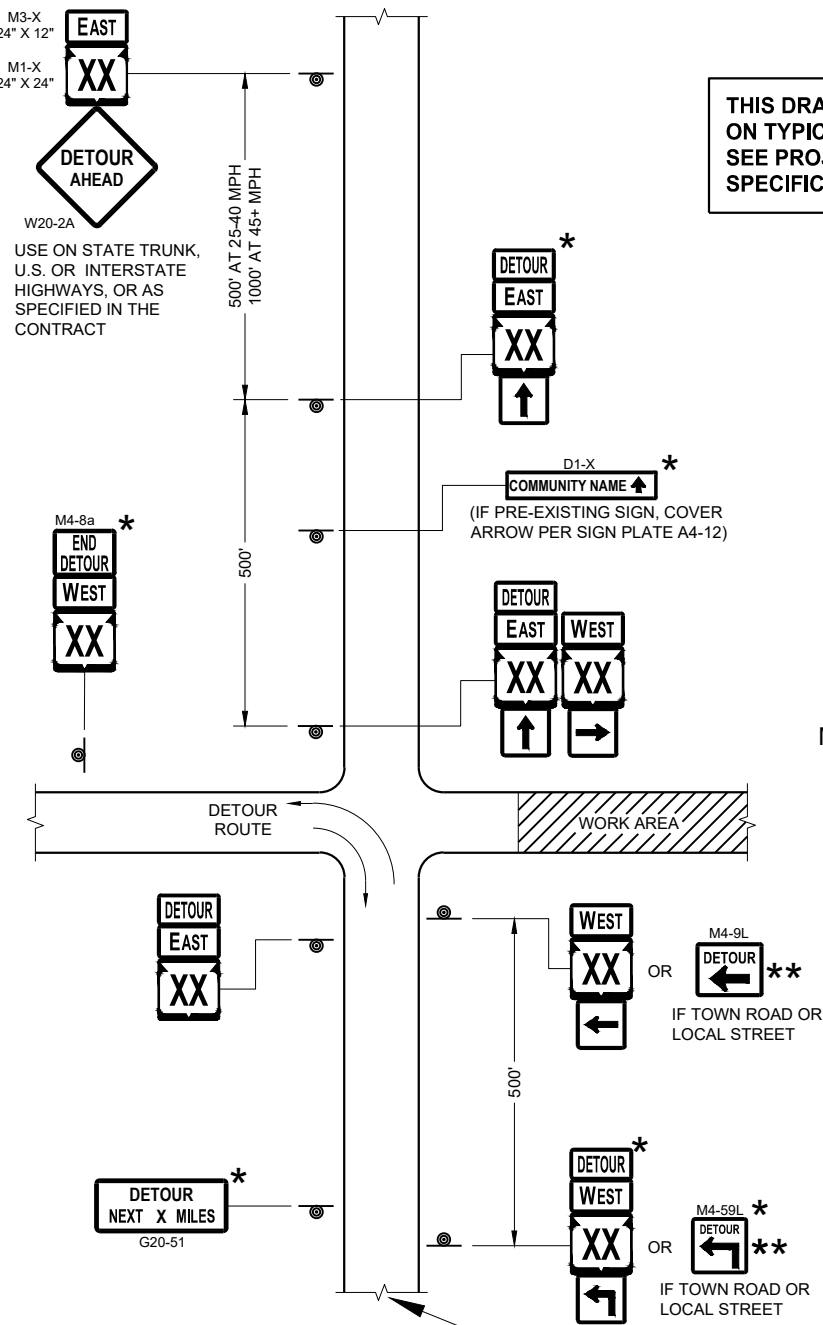

SEE SPECIFIC PROJECT DETOUR SIGNING DETAIL SHEETS AND DETAIL A OR B ON SDD SHEET 15C02 - SHEET "a"

DETOUR SIGNING FOR MAINLINE CLOSURES	
STATE OF WISCONSIN DEPARTMENT OF TRANSPORTATION	
APPROVED February 2020 DATE	/S/ Andrew Heidtke WORK ZONE ENGINEER
FHWA	

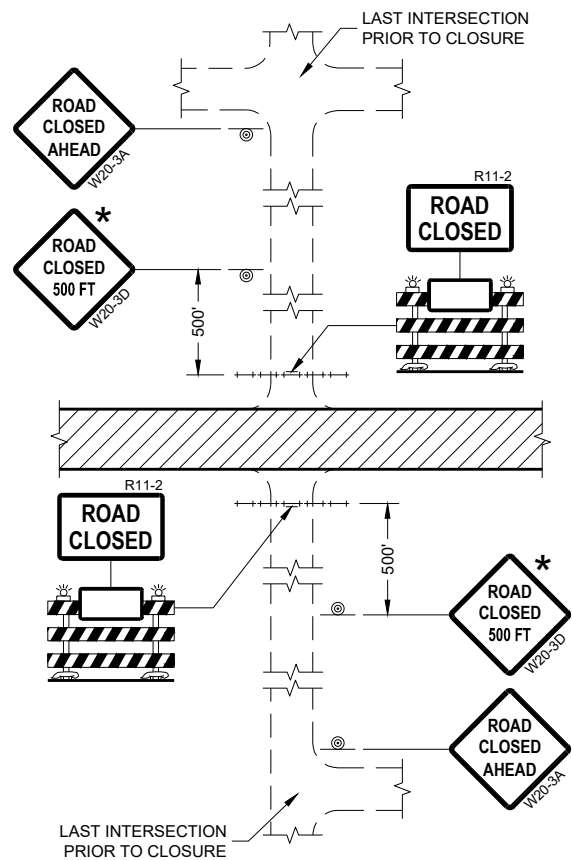

DETAIL 1
(NO ACCESS TO PROJECT)

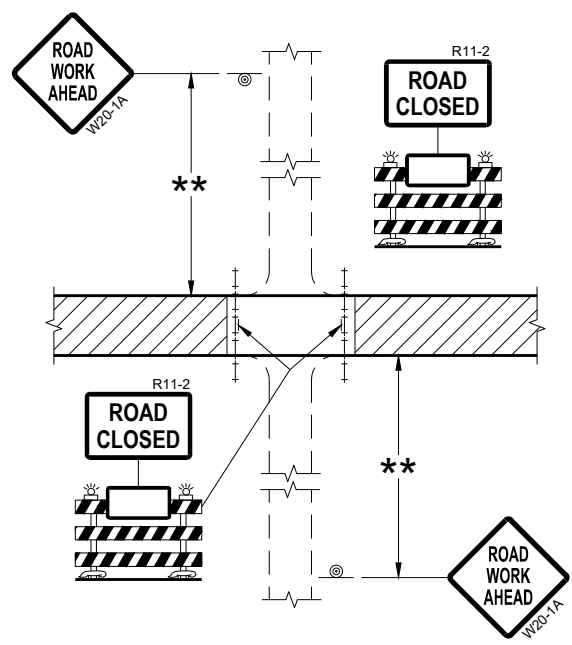

DETAIL 2
(PUBLIC CROSS-TRAFFIC MAINTAINED.
NO ACCESS TO PROJECT)

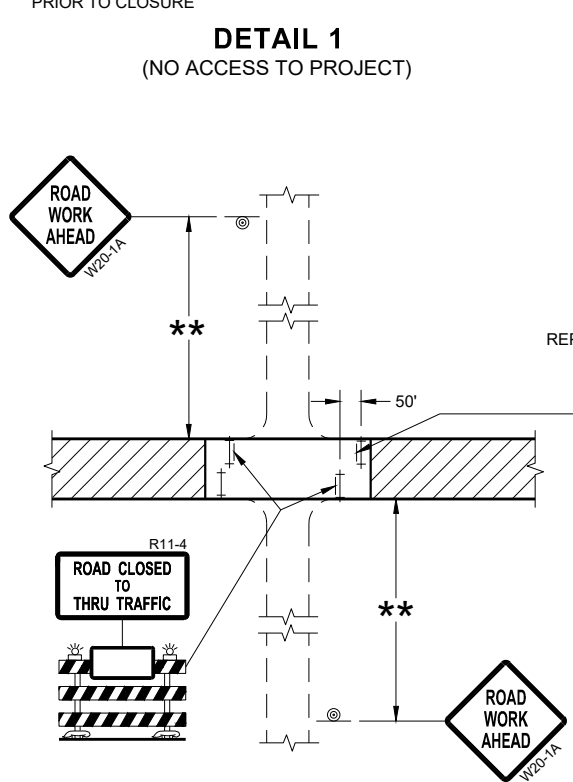

DETAIL 3
(PUBLIC CROSS-TRAFFIC MAINTAINED.
CONTRACTOR, LOCAL BUSINESS AND
RESIDENT ACCESS TO PROJECT)

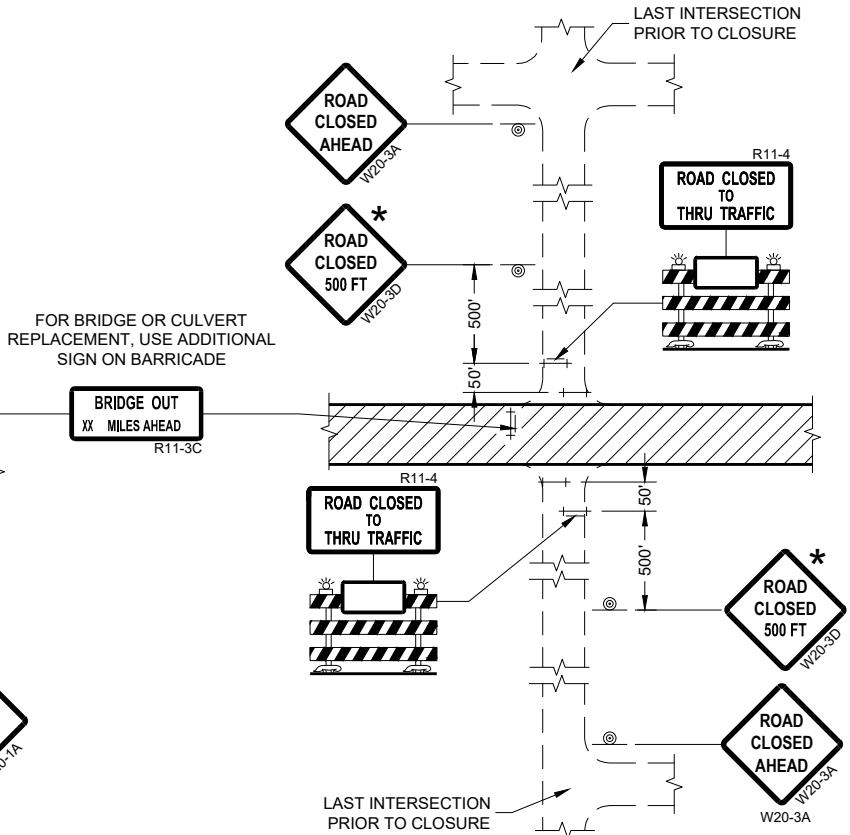

DETAIL 4
(CONTRACTOR, LOCAL BUSINESS AND
RESIDENT ACCESS TO PROJECT)

GENERAL NOTES

THE EXACT NUMBER, LOCATION, AND SPACING OF ALL SIGNS AND BARRICADES SHALL BE ADJUSTED TO FIT FIELD CONDITIONS AS APPROVED BY THE ENGINEER.

ANY SIGNS TEMPORARY OR EXISTING, WHICH CONFLICT WITH TRAFFIC CONTROL "IN USE" SHALL BE REMOVED OR COVERED AS NEEDED AND AS APPROVED BY THE ENGINEER.

THE SPACING BETWEEN TRAFFIC CONTROL SIGNS SHOULD BE ADJUSTED TO NOT CONFLICT WITH AND SHOULD PROVIDE A DESIRABLE MINIMUM OF 200 FEET CLEARANCE (500 FEET DESIRABLE) TO EXISTING SIGNS THAT WILL REMAIN IN PLACE.

IF A "STOP" SIGN MUST BE REMOVED FOR A WORK OPERATION, A TEMPORARY "STOP" SIGN SHALL BE PLACED PRIOR TO THE SIGN REMOVAL, OR A FLAGGER SHALL BE PROVIDED UNTIL THE SIGN IS REESTABLISHED.

BARRICADES THAT MUST BE MOVED FOR A WORK OPERATION SHALL BE IMMEDIATELY REESTABLISHED UPON COMPLETION OF THE OPERATION OR FOR CONTINUING OPERATIONS, AT THE END OF EACH WORKING DAY.

SIGNS THAT WILL BE IN PLACE LESS THAN SEVEN CONTINUOUS DAYS AND NIGHTS MAY BE MOUNTED ON PORTABLE SUPPORTS.

ALL TYPE III BARRICADES SHALL HAVE RAILS REFLECTORIZED ON BOTH FACES. STRIPES SHALL BE PROPERLY SLOPED DOWN TOWARD THE TRAFFIC SIDE OR AS SHOWN IN THE ROAD CLOSURE BARRICADE DETAIL "D" FOR FULL ROAD CLOSURES.

TYPE "A" LOW-INTENSITY FLASHING WARNING LIGHTS SHALL BE VISIBLE ON BOTH SIDES OF THE BARRICADE.

THE R11-2, R11-3, AND R11-4 SIGNS PLACED ON BARRICADES SHALL COVER NO MORE THAN THE TOP RAIL. THE SIGNS SHALL NOT COVER ANY PORTION OF THE MIDDLE OR BOTTOM RAILS.

ALL SIGNS SHALL BE 48" X 48" UNLESS OTHERWISE NOTED BELOW:
R11-2 SHALL BE 48" X 30".
R11-4 AND R11-3 SHALL BE 60" X 30".

- * OMIT THE "ROAD CLOSED 500 FT." SIGN IF THE LAST INTERSECTION IS 500 FEET OR LESS FROM THE WORK ZONE.
- ** 500' MAX. OR AT LAST INTERSECTION, WHICHEVER IS CLOSEST.

LEGEND

- ⊙ SIGN ON PERMANENT SUPPORT
- TYPE III BARRICADE
- TYPE III BARRICADE WITH ATTACHED SIGN
- ⚡ TYPE "A" WARNING LIGHT (FLASHING)
- ▨ WORK AREA

**BARRICADES AND SIGNS
FOR
SIDEROAD CLOSURES**

STATE OF WISCONSIN
DEPARTMENT OF TRANSPORTATION

APPROVED
July 2018 /S/ Andrew Heidtke
DATE WORK ZONE ENGINEER

TYPICAL ASSEMBLIES

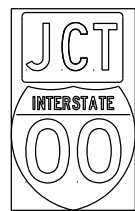

J1-1

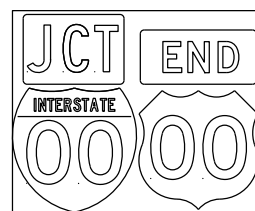

J1-2

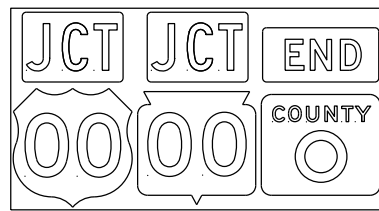

J1-3



JR1-1

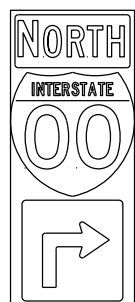

J2-1

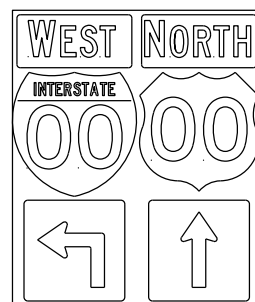

J2-2

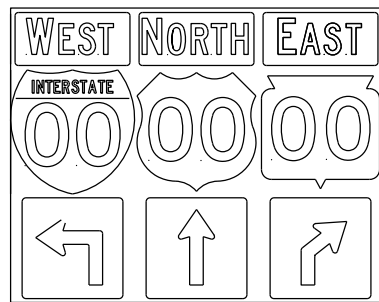

J2-3

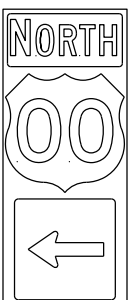

J3-1

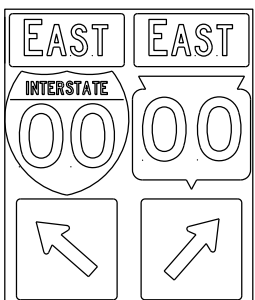

J3-2

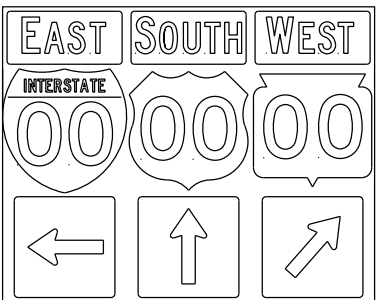

J3-3

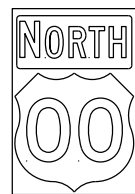

J4-1

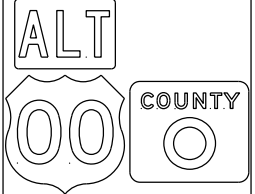

J4-2

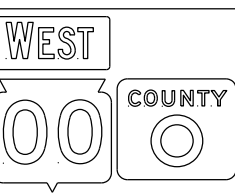

J4-2

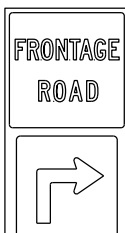

J12-1

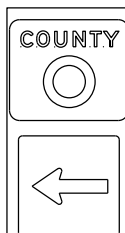

J13-1

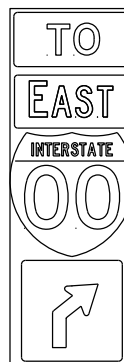

J32-1

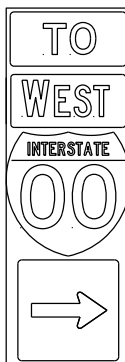

J33-1

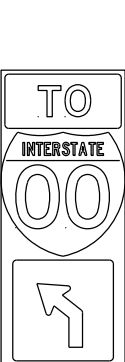

J22-1

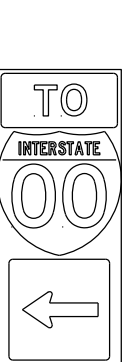

J23-1



JR13-1



JR23-1



JR99-1



JV

(Typical Vertical J-Assembly See Note 10 and 11)

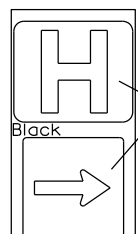

JH-1

Blue Background

blue background with interstate

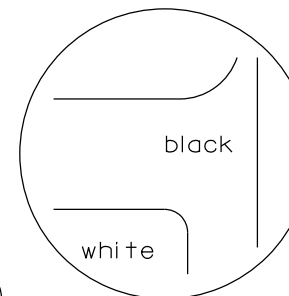
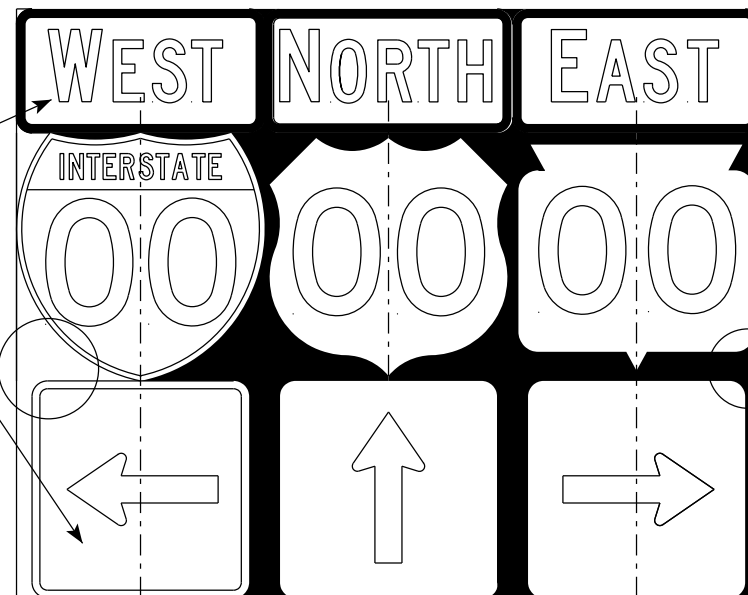
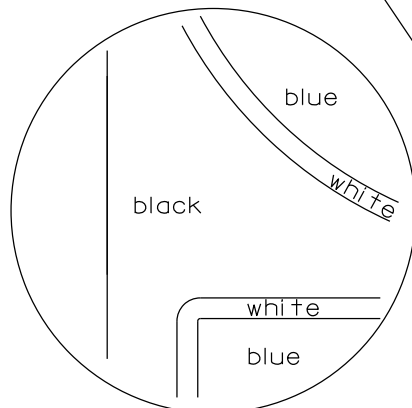

black background

NOTES

- Signs are Type II - Type H Reflective
- Color:
 - Background - Black Non-reflective
 - Message - see Note 5
- Message Series - See Note 5
- Corners shall be square or rounded if base material is plywood. If base material is metal the corners shall be rounded.
- The colors and message spacing on each marker shall be according to the applicable route marker panel specifications.
- Certain marker heads require the component pieces to be the same color. As an example, all the components used with an MI-1 Interstate marker shall be blue.
- Single panel j-assemblies shall only be used with route marker shields that are same size. If the route marker shields are different size use multiple piece component.
- Route assemblies that have 24 inch route shields and have dimensions greater than 48 inches (both vertical and horizontal) shall have one horizontal splice between the arrows and route shields. Vertical splices shall not be used on route assemblies with a horizontal dimension of 144 inches or less. The contractor shall not use more than one vertical joint per sign and the joint shall be between route shields.
- Route assemblies that have 36 inch shields and have dimensions greater than 48 inches (both vertical and horizontal) shall have two horizontal splices. One horizontal splice shall be between the cardinal direction and route shields and the other horizontal splice shall be between the arrows and route shields. Vertical splices shall not be used on route assemblies with a horizontal dimension of 144 or less. The contractor shall not use more than one vertical joint per sign and the joint shall be between route shields.
- All Vertical J Assemblies are given a Sign Code of JV
- For JV Assemblies that have a mixture of Interstate and non Interstate shields, arrows and cardinals shall be white on blue.

7

7

PROJECT NO:

FILE NAME : C:\CAEfiles\Projects\tr_stdplote_A21S.dgn

PLOT DATE : 18-MAR 2021 1:37

PLOT BY : mscj9h

PLOT NAME :

SHEET NO:

E

ROUTE MARKERS & COMPONENTS
IN TYPICAL ASSEMBLIES

WISCONSIN DEPT OF TRANSPORTATION

APPROVED

Matthew R. Rauch
for State Traffic Engineer

DATE 3/18/21

PLATE NO. A2-1S.9

WISDOT/CADDS SHEET 42

URBAN AREA

RURAL AREA (See Note 2)

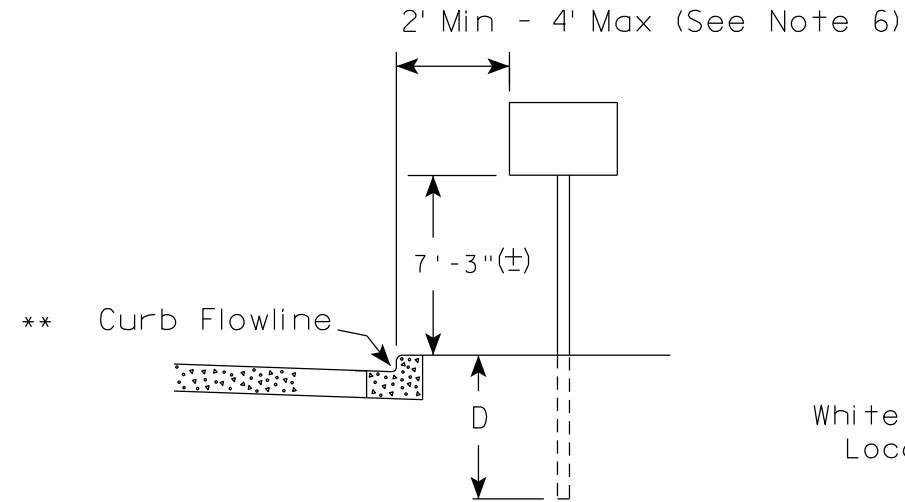

White Edgeline Location

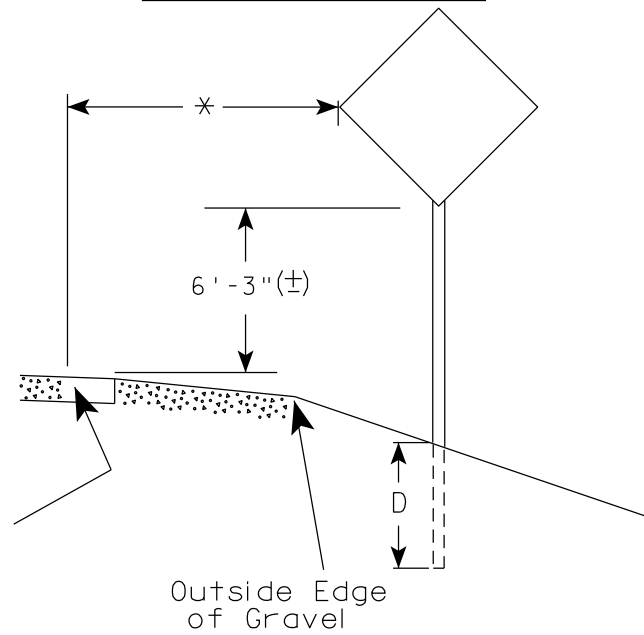

Outside Edge of Gravel

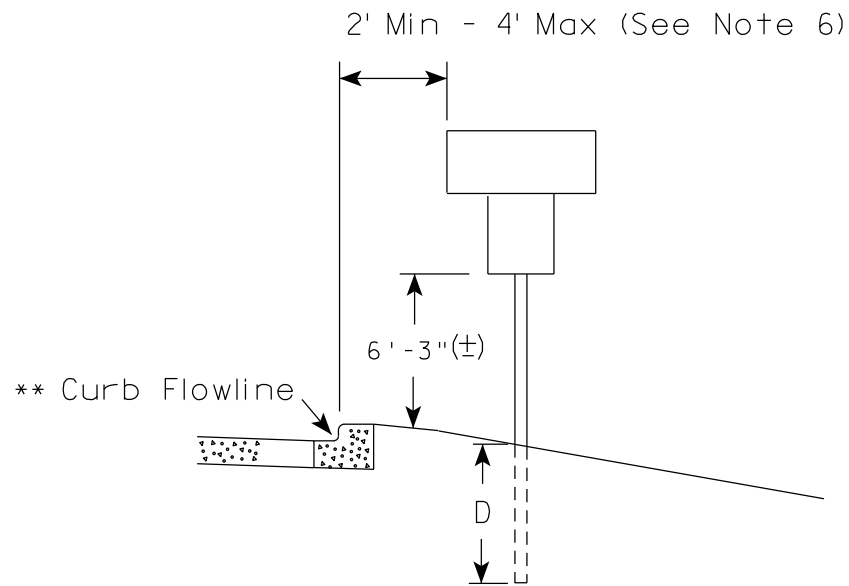

White Edgeline Location

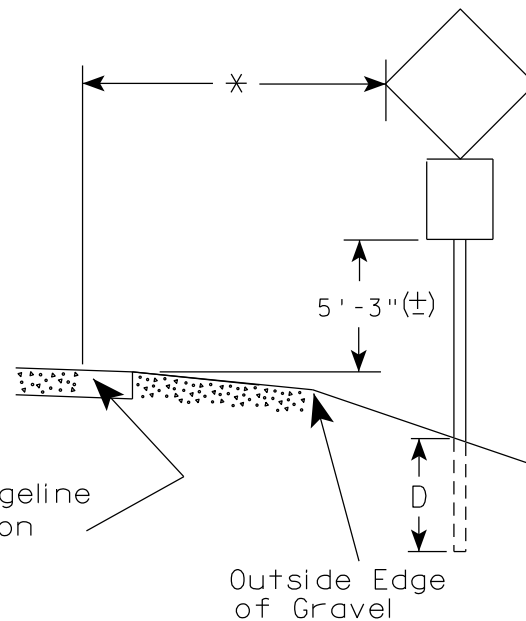

Outside Edge of Gravel

POST EMBEDMENT DEPTH

Area of Sign Installation (Sq. Ft.)	D (Min)
20 or Less	4'
Greater than 20	5'

GENERAL NOTES

1. Signs wider than 4 feet or 20 sq.ft or larger, shall be mounted on multiple posts. Refer to plate A4-4.
2. If signs are mounted on or behind barrier wall, see A4-10 sign plate.
The Double Arrow sign (W12-1D) shall be mounted at a height of 2'-3" (±). The Chevron sign (W1-8), Roundabout Chevron panel (R6-4B), Enhanced Reference Markers, Clearance Markers (W5-52), Mile Markers (D10 series), In Road Object Markers (W5-54) & End of Road Markers (W5-56) shall be mounted at a height of 4'-3" (±).
3. For expressways and freeways, mounting height is 7'- 3" (±) or 6'-3" (±) depending upon existence of a sub-sign.
4. Minimum mounting height for signs mounted on traffic signal poles is 5'- 3" (±).
5. Offset distance shall be consistent with existing signs or consistent throughout length of project.
6. The (±) tolerance for mounting height is 3 inches.
7. Folding signs shall be mounted at a height of 5'-3" (±) or as directed by the Engineer.

* * The existence of curb and gutter does not in itself mandate the vertical clearance illustrated. That height is typically measured where there is sidewalk adjacent to the roadway or parking is permitted. In the absence of sidewalk vertical clearance is measured from the top of the curb. Offset of signs is measured from the flow line.

* 6 feet from edge of a paved shoulder or 12 feet from the edge of pavement (edge line location) or 2 feet from outside edge of gravel, whichever is greater unless directed by project engineer.

TYPICAL INSTALLATION OF PERMANENT TYPE II SIGNS ON SINGLE POSTS

WISCONSIN DEPT OF TRANSPORTATION

APPROVED *Matthew R. Rauch*
for State Traffic Engineer

DATE 5/13/2020 PLATE NO. A4-3.22

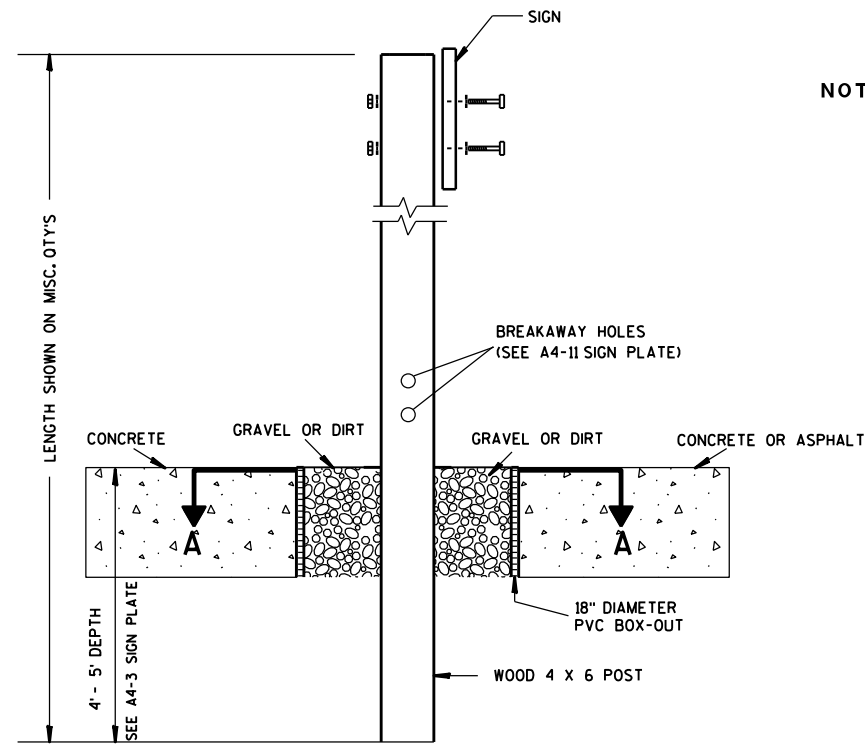

ELEVATION VIEW

DETAIL OF WOOD 4 X 6 SIGN POST IN BOX-OUT

- NOTES:**
1. ALL MATERIAL TO BE APPROVED BY ENGINEER PRIOR TO INSTALLATION
 2. SEE SIGN PLATE A4-8 FOR SIGN HARDWARE REQUIREMENTS
 3. 18 INCH X 18 INCH SQUARE BOX-OUTS MAY BE USED FOR INSTALLATIONS IN EXISTING CONCRETE OR ASPHALT LOCATIONS.

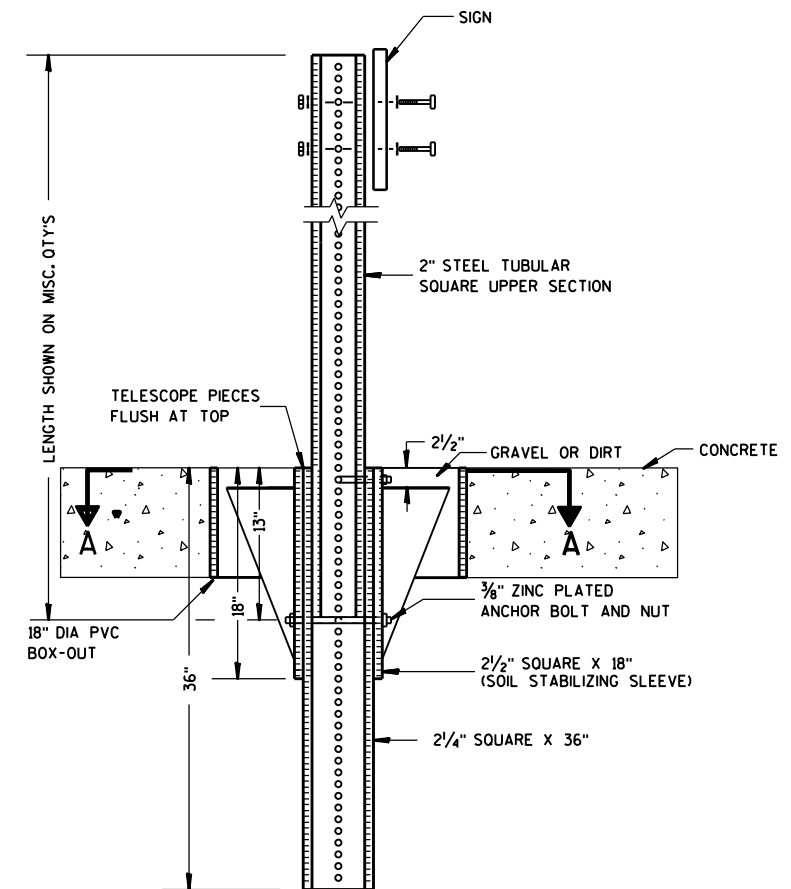

ELEVATION VIEW

DETAIL OF STEEL 2 X 2 SIGN POST IN BOX-OUT

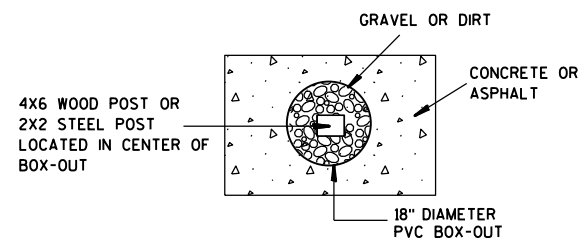

PLAN VIEW

FOR NEW CONCRETE/ASPHALT INSTALLATIONS

SIGN POST BOX-OUTS A4-3B	
<small>WISCONSIN DEPT OF TRANSPORTATION</small>	
APPROVED <i>Matthew R. Rauch</i> <small>for State Traffic Engineer</small>	
DATE <u>1/27/14</u>	PLATE NO. <u>A4-3B.1</u>

GENERAL NOTES

1. For 3 or 4 post installations, individual post spacing shall be greater than 3'-6".
2. See tables below for required number of posts.
3. For expressways and freeways, mounting height is 7'-3" (±) or 6'-3" (±) depending upon existence of sub-sign.
4. The (±) tolerance for mounting height is 3 inches.
5. J-Assemblies are considered to be one sign for mounting height.
6. Offset distance shall be consistent with existing signs or consistent throughout length of project.
7. Folding signs shall be mounted at a height of 5'-3" (±) or as directed by the engineer.
8. The Double Arrow sign (W12-1) shall be mounted at a height of 2'-3" (±). The Chevron sign (W1-8), Roundabout Chevron panel (R6-4B), Clearance Markers (W5-52), Mile Markers (D10 series), In Road Object Markers (W5-54) & End of Road Markers (W5-56) shall be mounted at a height of 4'-3" (±).

URBAN AREA

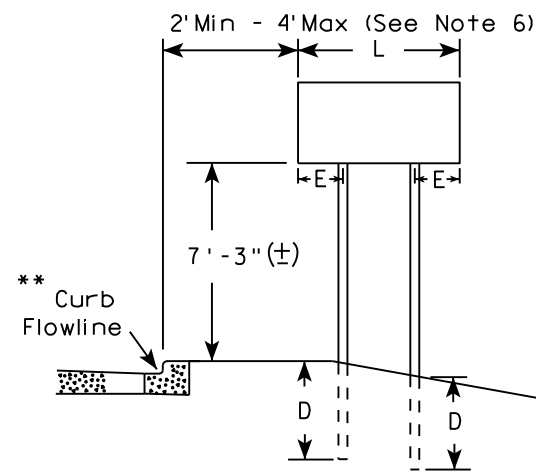

RURAL AREA (See Note 3)

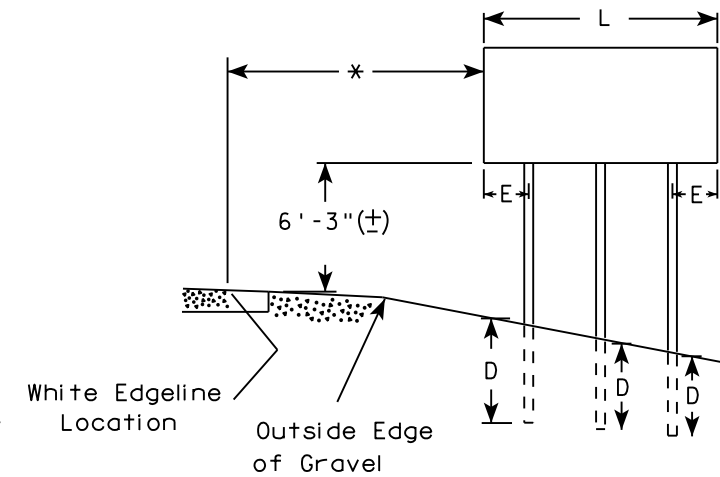
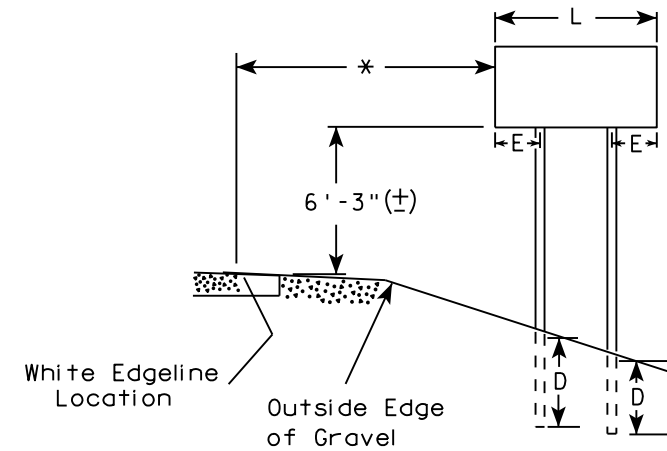

2' Min - 4' Max (See Note 6)

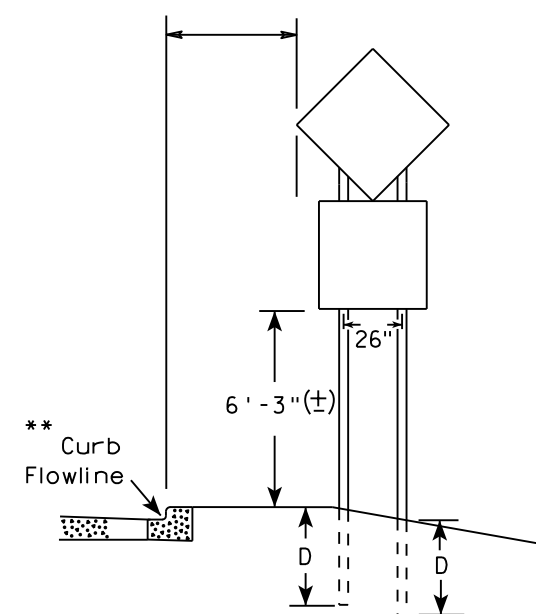

48" DIAMOND WARNING SIGN

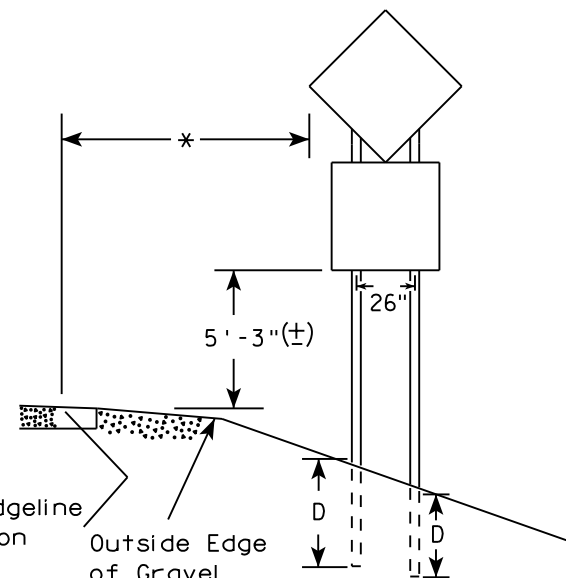

48" DIAMOND WARNING SIGN

* 6 feet from edge of a paved shoulder or 12 feet from the edge of pavement (edge line location) or 2 feet from outside edge of gravel, whichever is greater unless directed by project engineer.

** The existence of curb and gutter does not in itself mandate the vertical clearance illustrated. That height is typically measured where there is sidewalk adjacent to the roadway or parking is permitted. In the absence of sidewalk vertical clearance is measured from the top of the curb. Offset of signs is measured from the flow line.

*** See A4-3 sign plate for signs 4' or less in width and less than 20 S.F. in area.

SIGN SHAPE OTHER THAN DIAMOND (TWO POSTS REQUIRED)	
L	E
Greater than 48" Less than 60"	12"
60" to 108"	L/5

SIGN SHAPE OTHER THAN DIAMOND (THREE POSTS REQUIRED)	
L	E
Greater than 108" to 144"	12"

POST EMBEDMENT DEPTH

Area of Sign Installation (Sq. Ft.)	D (Min)
20 or Less	4'
Greater than 20	5'

TYPICAL INSTALLATION OF TYPE II SIGNS ON MULTIPLE POSTS

WISCONSIN DEPT OF TRANSPORTATION
 APPROVED *Matthew R. Rauch*
 For State Traffic Engineer
 DATE 8/21/17 PLATE NO. A4-4.15

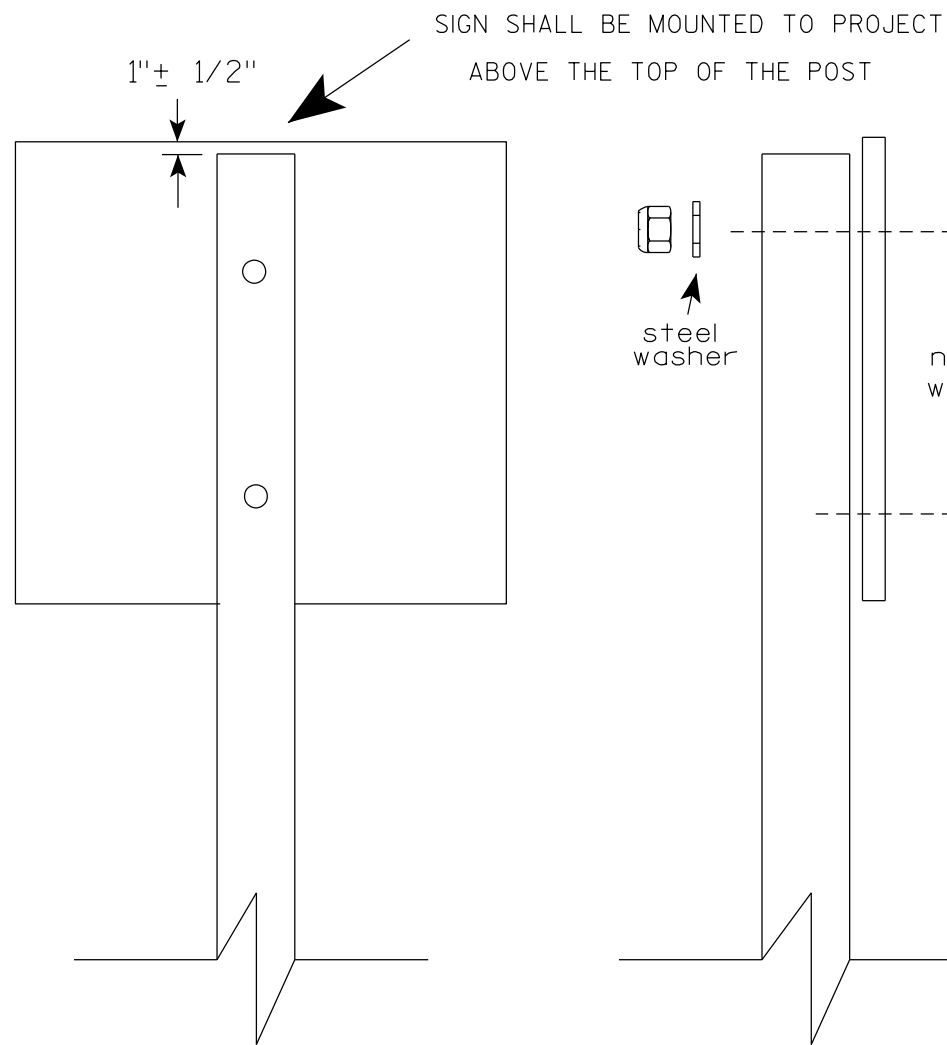

Nuts, bolts and lags used for mounting signs shall have hexagonal heads and shall be either :

- a. Hot dip galvanized in accordance with ASTM Designation: A 153, Class D, or SC 3
- b. Electro-galvanized in accordance with ASTM Designation : B 633, TYPE III, SC 3.

Threads on bolts and nuts shall be manufactured with sufficient allowance for the cadmium plate or galvanized coating to permit the nuts to run freely on the bolts.

STRINGER BOLTING TO ALUMINUM SIGNS (SEE SIGN PLATE A4-18)

MACHINE BOLTS - 5/16" X 1-3/4" Length w/ lock nuts

WOOD POSTS (4" x 6")

LAG SCREWS - 3/8" X 3" (NO STRINGERS ON BACK OF SIGN)
3/8" X 4" (STRINGERS ON BACK OF SIGN)

SQUARE STEEL POSTS (2" x 2")

MACHINE BOLTS - 3/8" X 3-1/4" Length w/ nuts (NO STRINGER ON BACK OF SIGN)
3/8" X 5" Length w/ nuts (STRINGERS ON BACK OF SIGN)

RIVETS - 9/32" (6605-9-6) BULB-TITE, TRI-FOLD, ALUMINUM BODY/MANDREL
O.D. FLANGE .720-.765 INCH, GRIP RANGE .042-.375 INCH

WASHERS (ALL POSTS) -

1-1/4" O.D. X 3/8" I.D. X 1/16" STEEL

1-1/4" O.D. X 3/8" I.D. X .080 NYLON

* Two different fastening systems are shown for illustration purposes. On any individual sign, either one or the other system shall be used. Actual number of fasteners per sign varies with the sign area, but normally there are two. For a single post installation, all signs greater than 9 sq. ft. require the use of 3 fasteners.

ATTACHMENT OF SIGNS
TO POSTS

WISCONSIN DEPT OF TRANSPORTATION

APPROVED *Matthew R Rauch*
For State Traffic Engineer

DATE 4/1/2020 PLATE NO. A4-8.9

**TELESCOPIC TUBING ANCHORS
TWO PIECE SYSTEM**

2 1/4" SQUARE
12 GAUGE
PERFORATED
GALVANIZED FINISH

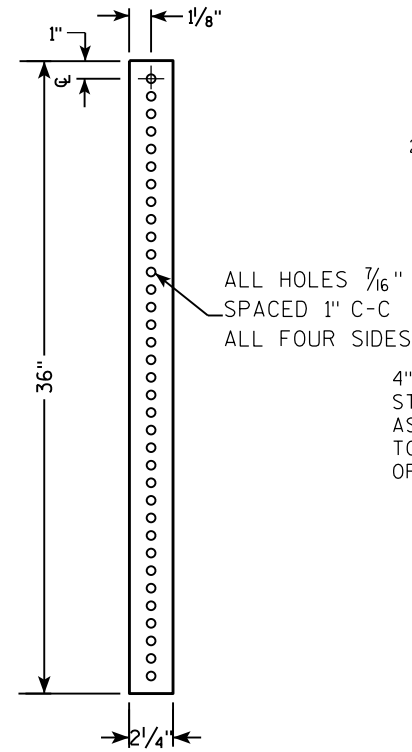

2 1/2" SQUARE
12 GAUGE
OMNI-DIRECTIONAL
PERFORATED
SOIL STABILIZING SLEEVE
GALVANIZED FINISH

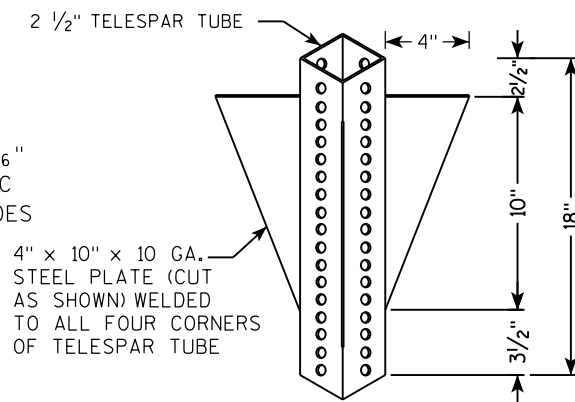

**DETAIL OF TUBULAR STEEL SIGN POST
(IN POURED CONCRETE OR ASPHALT)**

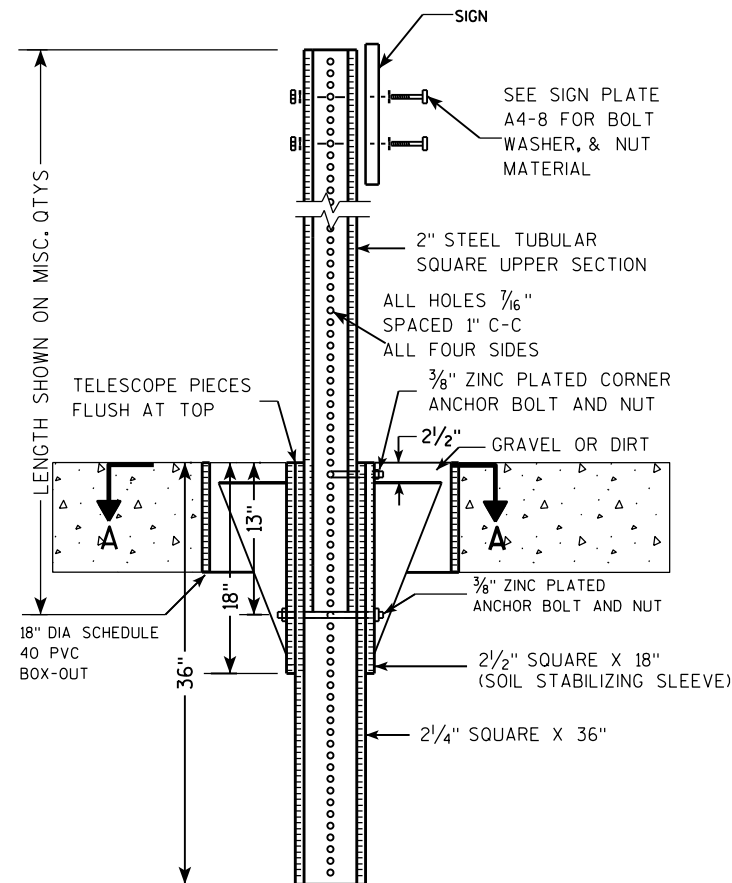

**DETAIL OF TUBULAR STEEL SIGN POST
(IN LOCATIONS OTHER THAN POURED CONCRETE OR ASPHALT)**

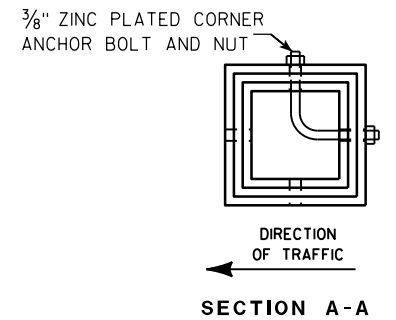
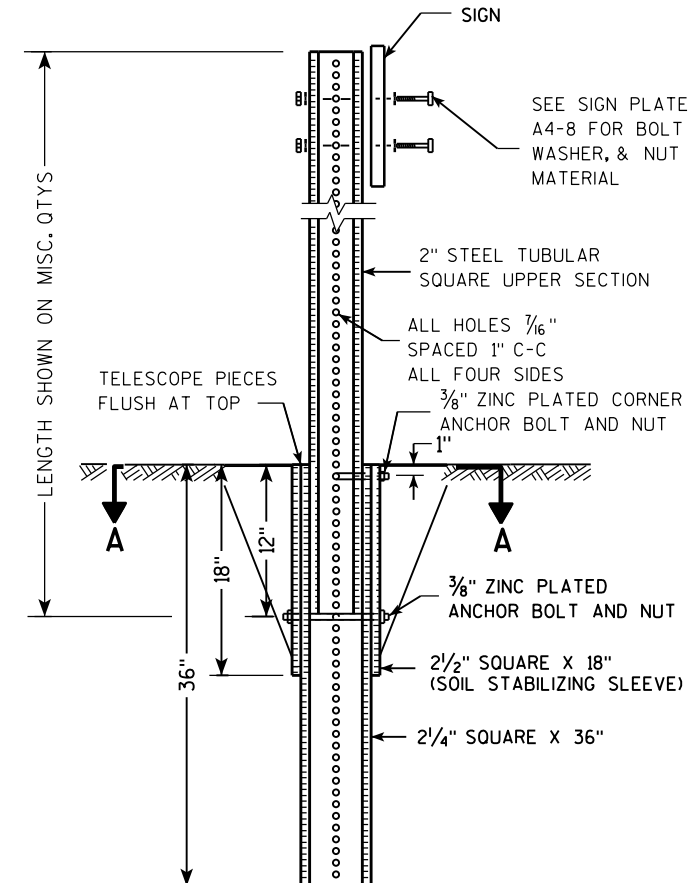

Area of Sign Installation (Sq. Ft.)	Number of Required Posts
9 or less	1
Greater than 9 less than or equal to 18	2
Greater than 18 less than or equal to 27	3

Signs wider than 3 feet or larger than 9 sq. ft shall be mounted on multiple posts (see above table).

**TUBULAR STEEL
SIGN POST
A4-9**

WISCONSIN DEPT OF TRANSPORTATION

APPROVED *Matthew R. Rauch*
for State Traffic Engineer

DATE 2/05/15 PLATE NO. A4-9.9

PROJECT NO:

HWY:

COUNTY:

SHEET NO:

E

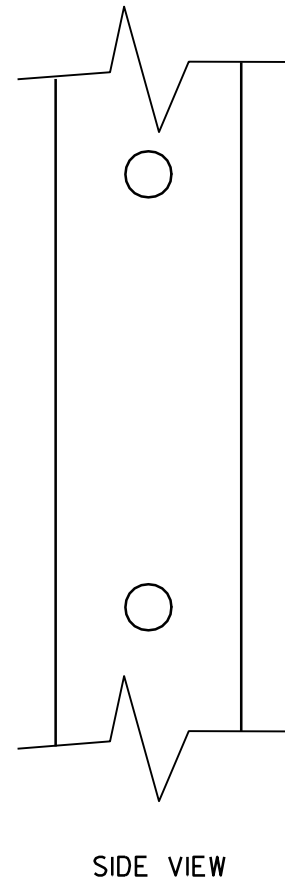
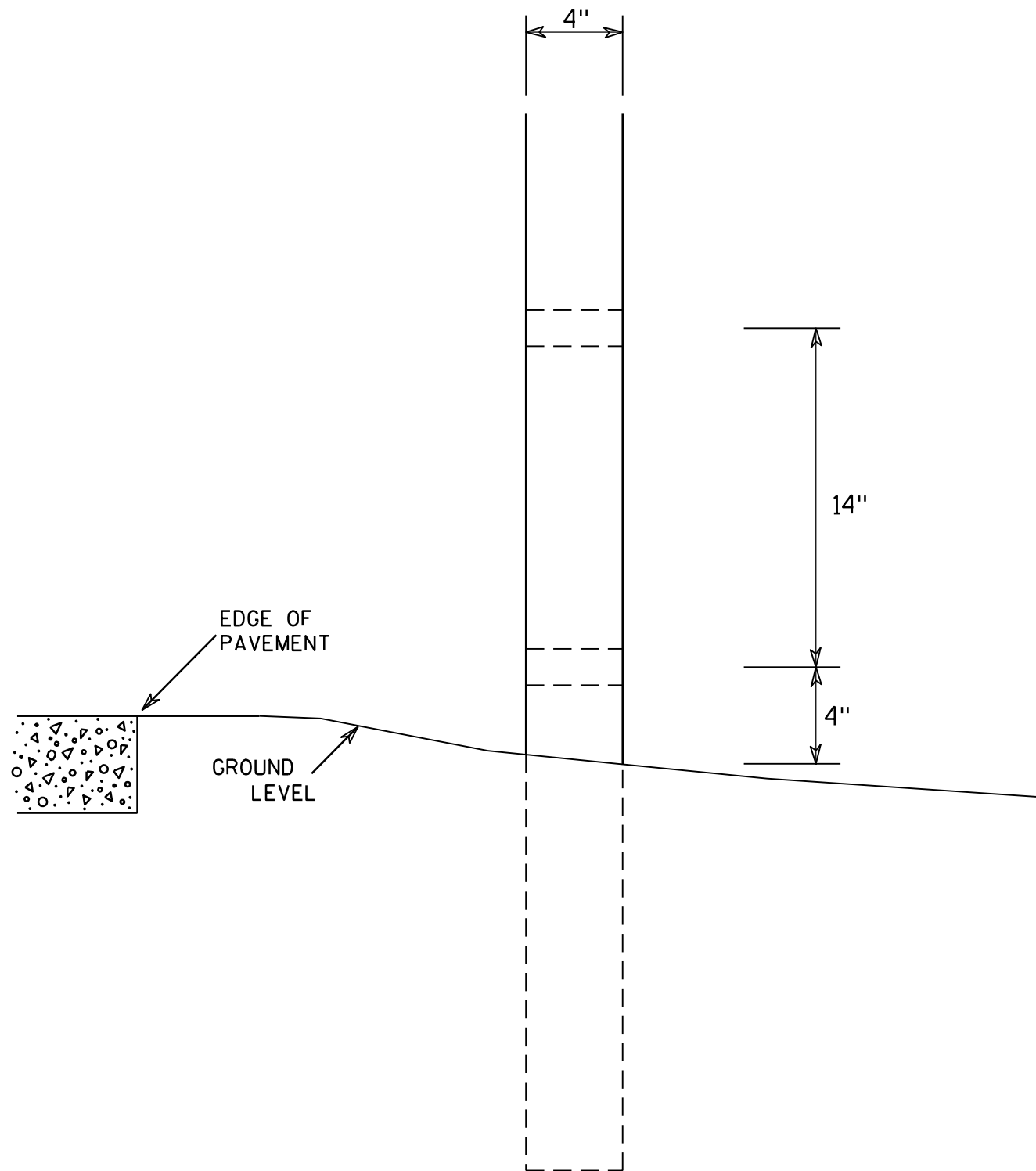

GENERAL NOTES

1. All 4 x 6 Wood Posts shall be modified by having two 1½" diameter holes drilled perpendicular to the roadway centerline.

7

7

4 X 6 WOOD POST MODIFICATIONS	
WISCONSIN DEPT OF TRANSPORTATION	
APPROVED	<i>Chester J Spang</i> for State Traffic Engineer
DATE 3/27/97	PLATE NO. A4-11.2

BANDING

SINGLE SIGN

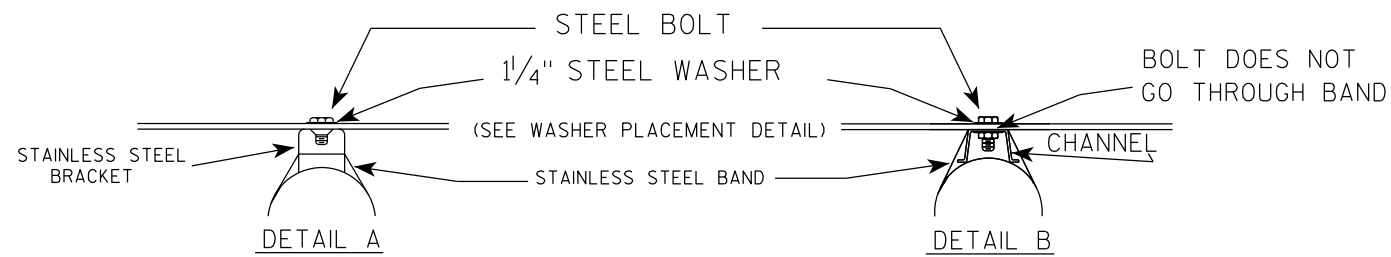
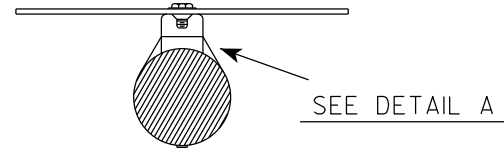
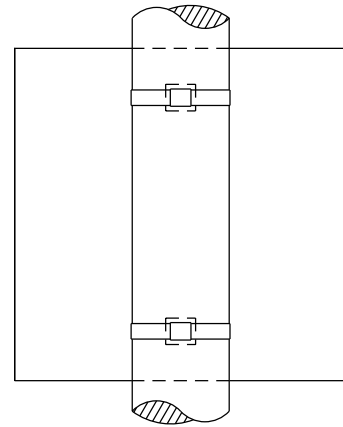

"J" ASSEMBLY

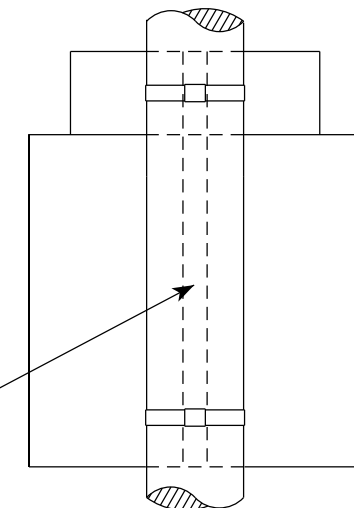

CHANNEL
SEE TYPICAL PANEL
INSTALLATION SHEET

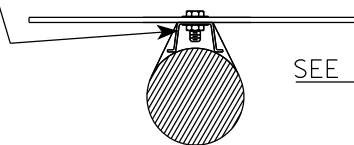

- GENERAL NOTES**
1. Any sign over 3 feet in width shall use the V-Block banding method. See A5-10 standard plate.
 2. Signs 3 feet or greater in height shall have three bracket bands installed. Signs less than 3 feet in height shall have two bracket bands installed.
 3. Banding and assembly bracket shall be stainless steel. All bands shall be $\frac{3}{4}$ " in width and 0.025" thickness.
 4. ALL SIGN MOUNTING BOLTS AND WASHERS SHALL BE EITHER:
 - a. Hot dip or mechanically galvanized in accordance with ASTM Designation: A 153, Class D
 - b. Electro-galvanized in accordance with ASTM designation: B 633, Type III, SC 3

WASHER PLACEMENT

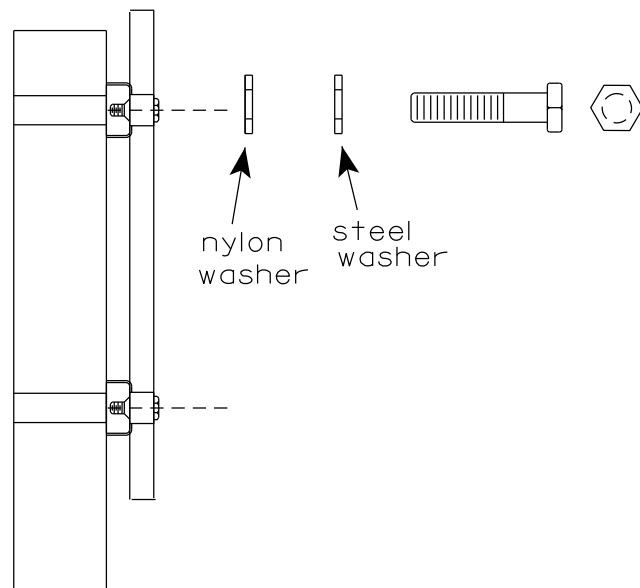

WASHERS (ALL POSTS) -
 1-1/4" O.D. X 3/8" I.D. X 1/16" STEEL
 1-1/4" O.D. X 3/8" I.D. X .080 NYLON
 FOR ALL TYPE H SIGNS

STANDARD SIGN
SIGN BANDING DETAILS

WISCONSIN DEPT OF TRANSPORTATION

APPROVED *Matthew R. Rauch*
for State Traffic Engineer

DATE 6/10/19 PLATE NO. A5-9.4

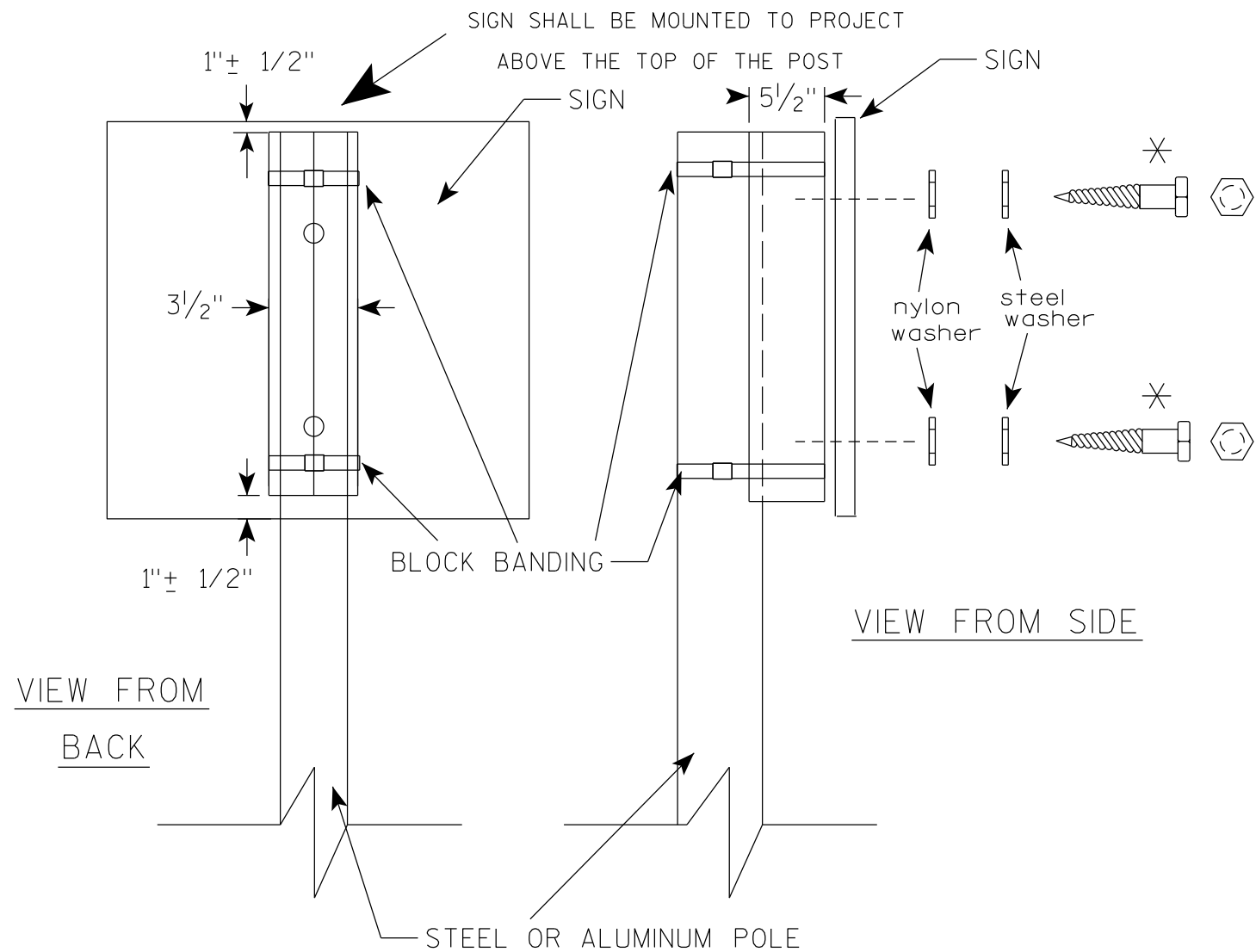

GENERAL NOTES

1. WOOD 4"X6" POST MATERIAL SHALL CONFORM TO 507.2.2 OF THE WisDOT STANDARD SPECIFICATIONS
2. BLOCK BANDING AND CLIPS SHALL BE STAINLESS STEEL, 3/4" WIDTH AND 0.025" THICKNESS
3. SIGNS 3' OR GREATER IN HEIGHT SHALL UTILIZE 3 BLOCK BANDS. SIGNS UNDER 3' IN HEIGHT SHALL UTILIZE 2 BLOCK BANDS
4. ACTUAL NUMBER OF FASTENERS PER SIGN VARIES WITH THE SIGN AREA, BUT NORMALLY THERE ARE TWO. FOR SIGNS GREATER THAN 9 S.F. 3 FASTENERS SHALL BE USED.
5. ALL SIGN MOUNTING BOLTS AND WASHERS SHALL BE EITHER:
 - a. Hot dip or mechanically galvanized in accordance with ASTM Designation: A 153, Class D
 - b. Electro-galvanized in accordance with ASTM Designation : B 633, TYPE III, SC 3
6. ALL BOLTS SHALL HAVE HEXAGONAL HEADS.
7. STEEL WASHERS SHALL BE 1/4" O.D. X 3/8" I.D. X 1/16"
8. NYLON WASHERS SHALL BE 1/4" O.D. X 3/8" I.D. X .080 FOR TYPE H OR TYPE F FACE SIGN

✱ LAG BOLTS SHALL BE 3/8" X 2 1/2"

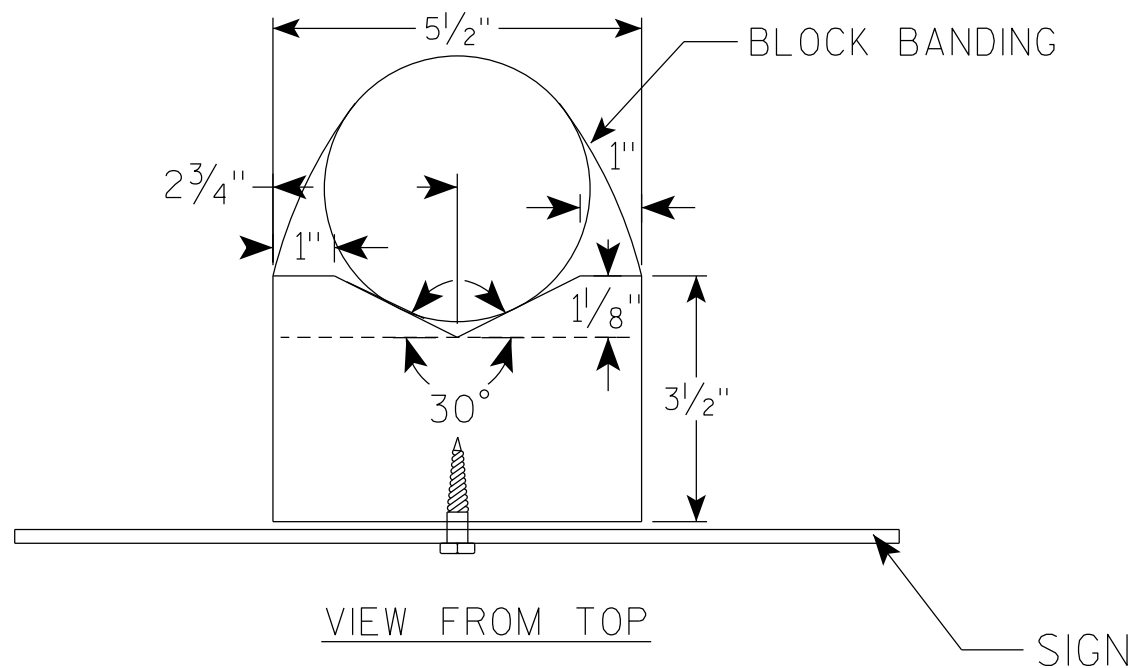

BLOCK BANDING DETAIL (V-BLOCK OPTION)	
WISCONSIN DEPT OF TRANSPORTATION	
APPROVED	<i>Matthew R Rauch</i> for State Traffic Engineer
DATE 6/10/19	PLATE NO. A5-10.2

NOTES

1. Sign is Type II - see Note 7 - reference WIS DOT Standard Specification for HIGHWAY and STRUCTURE CONSTRUCTION latest edition.
2. Color:
Background - White & Black - See Note 7
Message - Black
3. Message Series - see Note 5
4. Corners may be square or rounded when base material is plywood but borders shall be rounded as shown. When base material is metal, the corners and borders shall be rounded.
5. Message Series E for 1 letter.
Message Series D for 2 letters unless message is too big then Series C.
Message Series C for 3 letters unless message is too big then Series B.
6. Substitute appropriate letters & optically center to achieve proper balance.
7. Permanent Signs
Background - Type H Reflective
Detour or temporary Signs
Background - Reflective

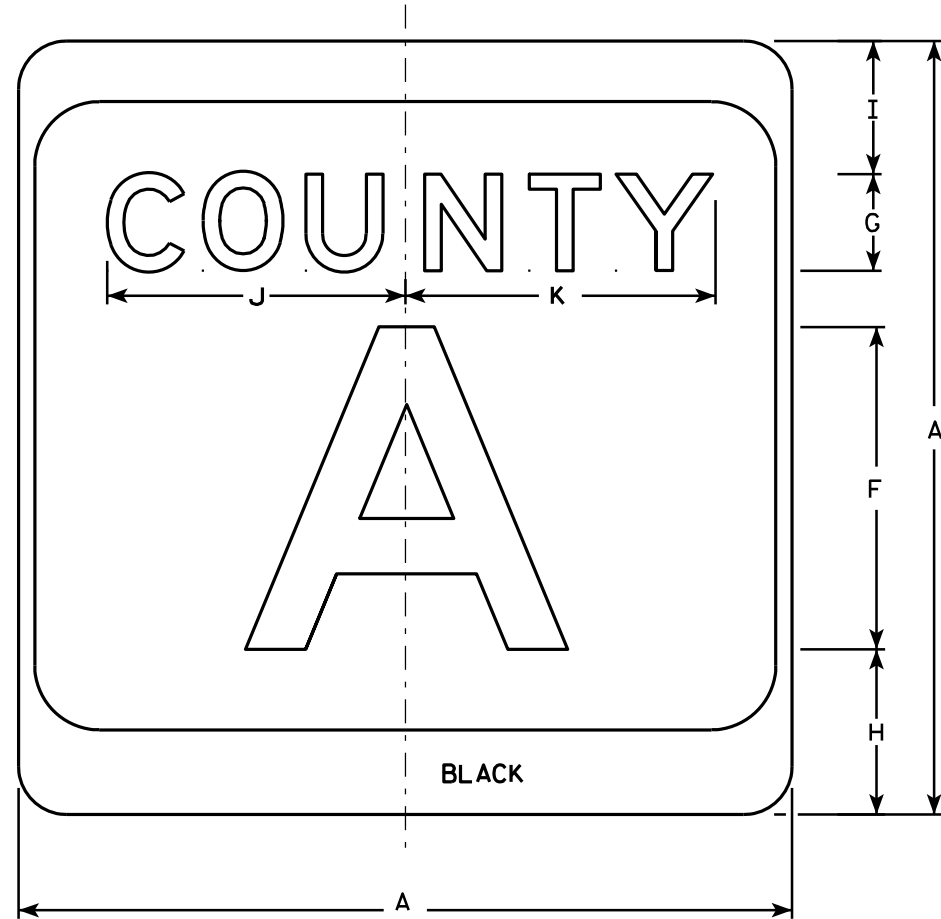

M1-5A

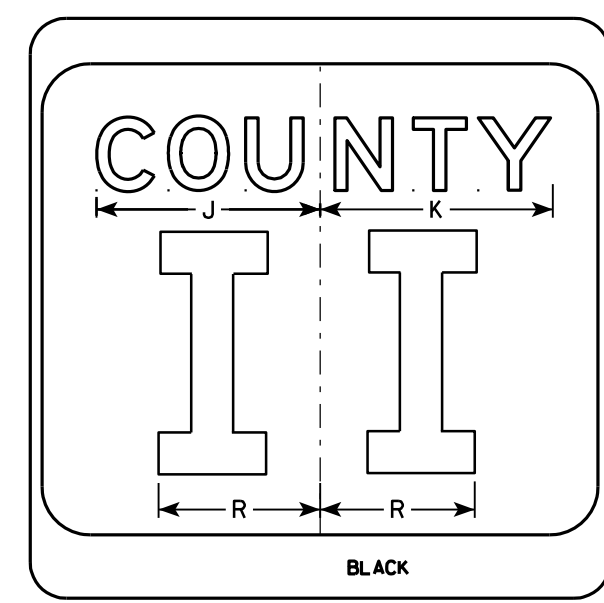
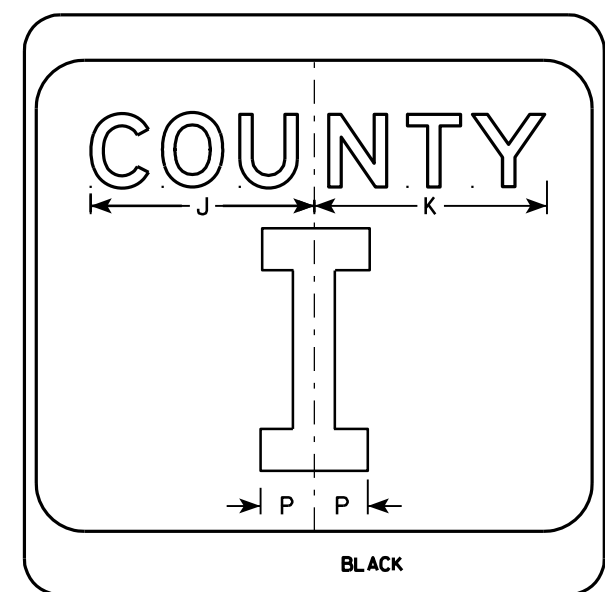
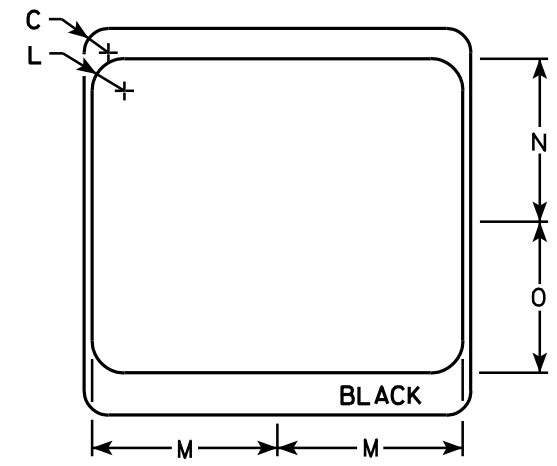

7

7

SIZE	A	B	C	D	E	F	G	H	I	J	K	L	M	N	O	P	Q	R	S	T	U	V	W	X	Y	Z	Area sq. ft.
1																											
2	24		1 1/2			10	3	5 1/8	4 1/8	9 1/4	9 5/8	2	11 1/2	10 1/8	9 3/8	2 1/4		6 5/8									4.0
3	36		2 1/4			16	4	7 5/8	5 5/8	12 1/4	12 7/8	3	17 1/8	15 1/4	14	3 3/8		10									9.0
4	36		2 1/4			16	4	7 5/8	5 5/8	12 1/4	12 7/8	3	17 1/8	15 1/4	14	3 3/8		10									9.0
5	36		2 1/4			16	4	7 5/8	5 5/8	12 1/4	12 7/8	3	17 1/8	15 1/4	14	3 3/8		10									9.0

CTH MARKER
M1-5A FOR ASSEMBLIES

WISCONSIN DEPT OF TRANSPORTATION

APPROVED *Matthew R. Raub*
For State Traffic Engineer

DATE 9/27/11 PLATE NO. MI-5A.8

PROJECT NO: _____ HWY: _____ COUNTY: _____ SHEET NO: **E**

NOTES

1. Sign is Type II - Type H Reflective
2. Color:
Background - White
Message - Black
3. Message Series - D except 3 number signs Series C
4. Corners may be square or rounded when base material is plywood but borders shall be rounded as shown. When base material is metal, the corners and borders shall be rounded.

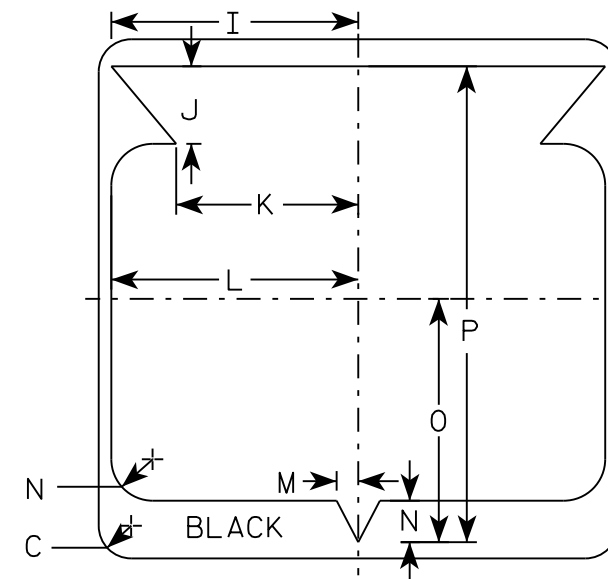
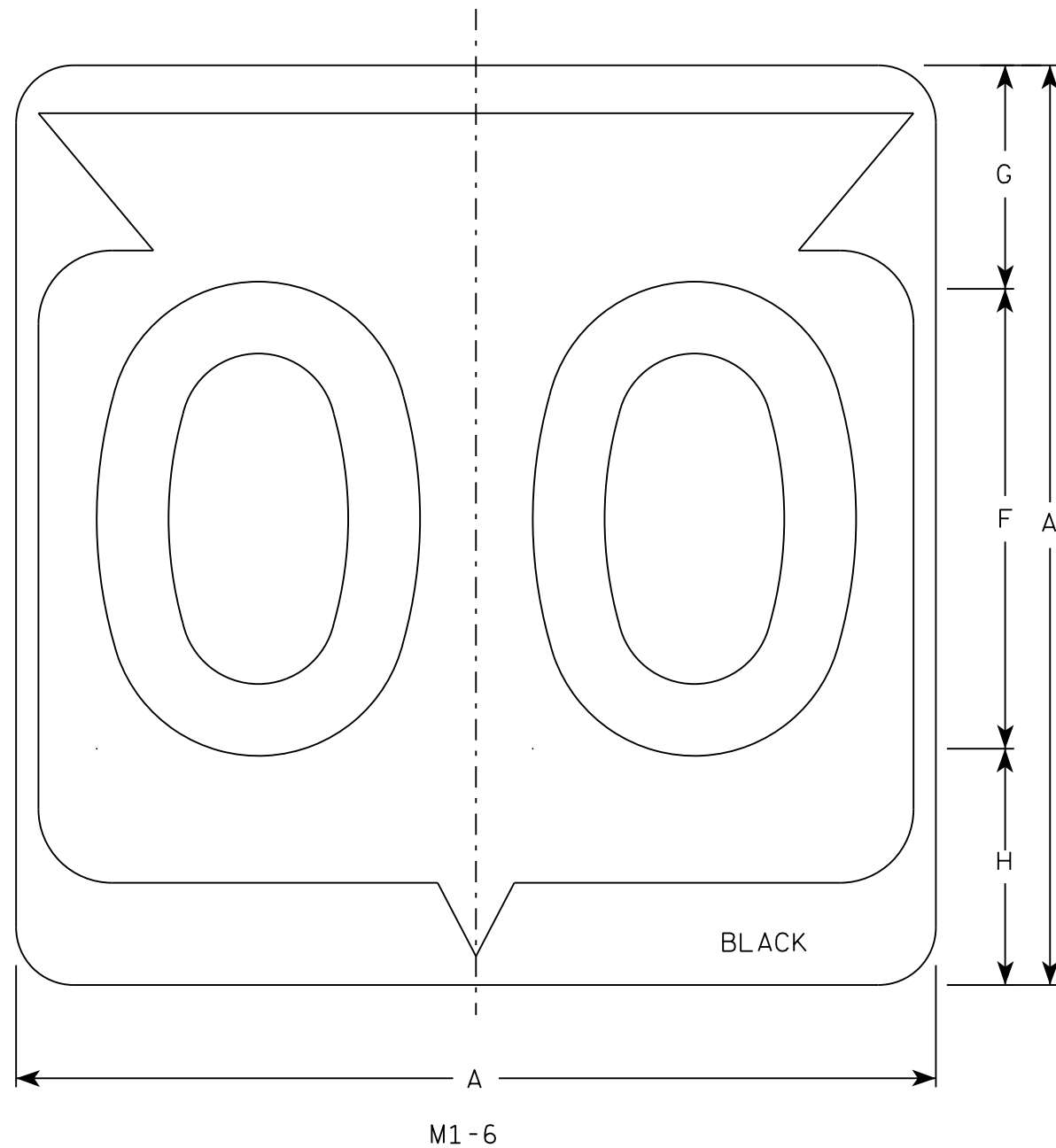

SIZE	A	B	C	D	E	F	G	H	I	J	K	L	M	N	O	P	Q	R	S	T	U	V	W	X	Y	Z	Area sq. ft.
1																											
2	24		1 1/2			12	5 1/2	6 1/2	10 1/4	2 1/2	8 7/8	11 1/2	1	1 7/8	11 1/4	21 7/8											4.0
3	36		2 1/4			18	8 3/4	9 1/4	15 3/8	5 3/8	12 5/8	17 1/8	1 1/2	2 7/8	16 7/8	33											9.0
4	36		2 1/4			18	8 3/4	9 1/4	15 3/8	5 3/8	12 5/8	17 1/8	1 1/2	2 7/8	16 7/8	33											9.0
5	36		2 1/4			18	8 3/4	9 1/4	15 3/8	5 3/8	12 5/8	17 1/8	1 1/2	2 7/8	16 7/8	33											9.0

STATE ROUTE MARKER
M1-6 FOR ASSEMBLIES

WISCONSIN DEPT OF TRANSPORTATION

APPROVED *Matthew R. Rauch*
for State Traffic Engineer

DATE 3/16/18 PLATE NO. M1-6.10

PROJECT NO: _____ HWY: _____ COUNTY: _____ SHEET NO: _____ **E**

NOTES

1. Sign is Type II - Type H
2. Color:
 - Background - See note 5
 - Message - See note 5
3. Message Series - C
4. Corners may be square or rounded when base material is plywood but borders shall be rounded as shown. When base material is metal, the corners and borders shall be rounded.
5. M2-1 Background - White
 Message - Black
 MB2-1 Background - Blue
 Message - White
 MK2-1 Background - Green
 Message - White
 MM2-1 Background - White
 Message - Green
 MN2-1 Background - Brown
 Message - White
 MP2-1 Background - White
 Message - Blue
 MR2-1 Background - Brown
 Message - Yellow

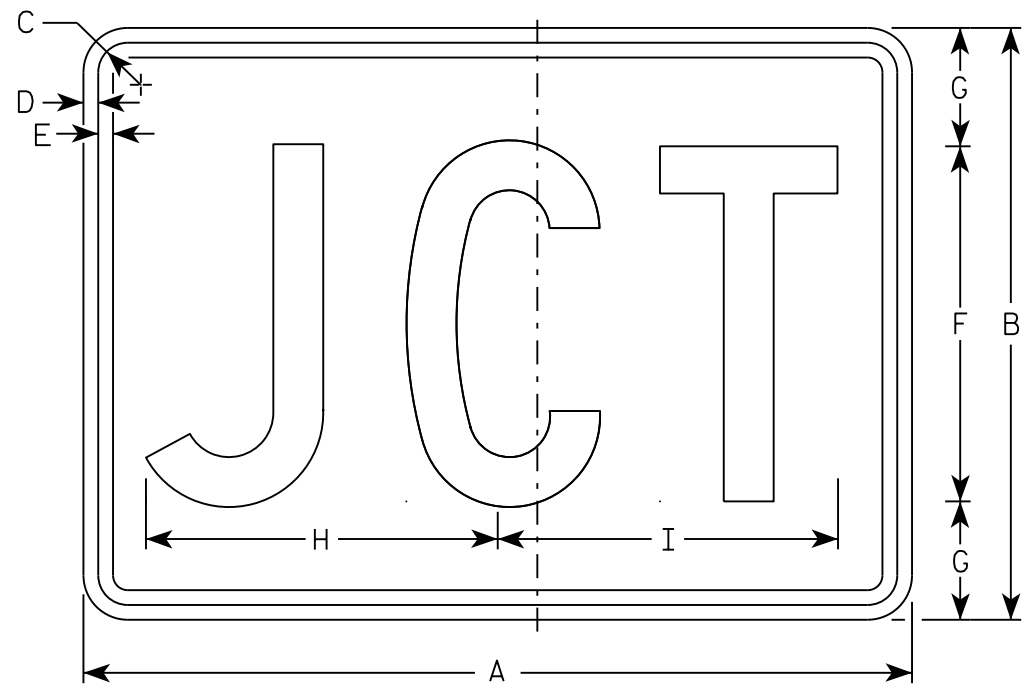

M2-1
MM2-1
MP2-1

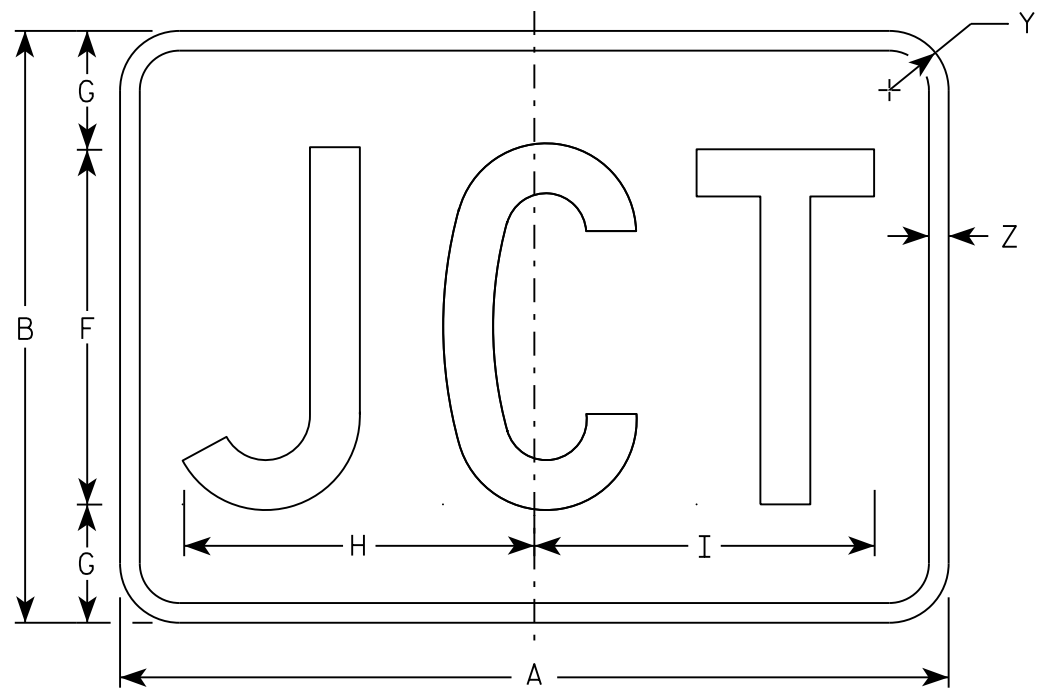

MB2-1
MK2-1
MN2-1
MR2-1

7

SIZE	A	B	C	D	E	F	G	H	I	J	K	L	M	N	O	P	Q	R	S	T	U	V	W	X	Y	Z	Area sq. ft.
1																											
2	21	15	1 1/8	3/8	3/8	9	3	8 7/8	8 5/8																1 1/2	1/2	2.20
3	30	21	1 1/8	3/8	3/8	13	4	12 7/8	12 3/8																1 1/2	1/2	4.40
4	30	21	1 1/8	3/8	3/8	13	4	12 7/8	12 3/8																1 1/2	1/2	4.40
5	30	21	1 1/8	3/8	3/8	13	4	12 7/8	12 3/8																1 1/2	1/2	4.40

STANDARD SIGN
M2-1

WISCONSIN DEPT OF TRANSPORTATION

APPROVED *Matthew R. Rauch*
For State Traffic Engineer

DATE 10/15/15 PLATE NO. M2-1.12

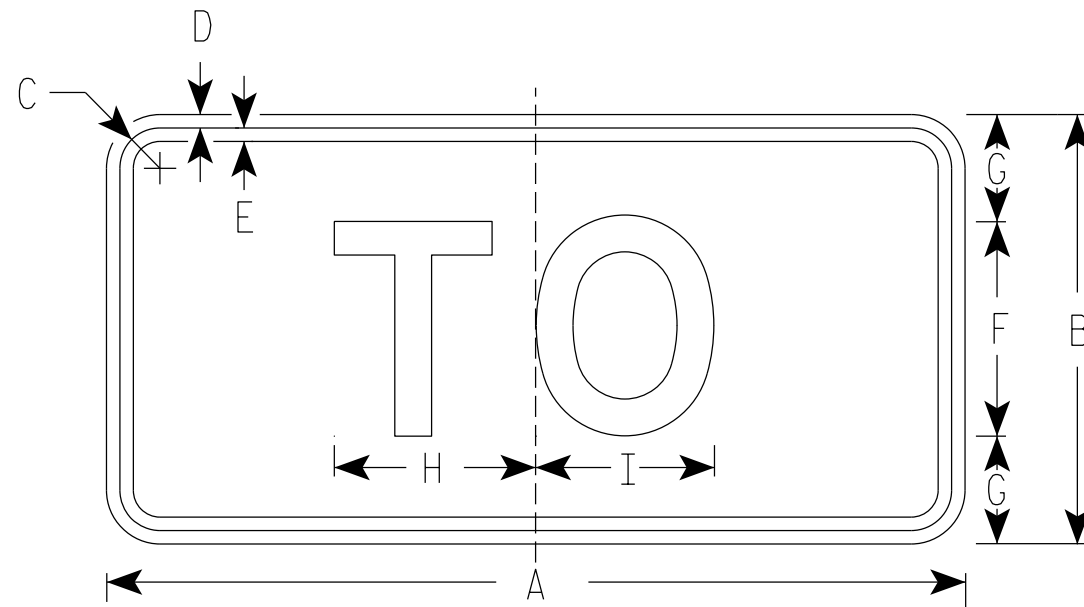

M4-5
MM4-5
MP4-5
M04-5

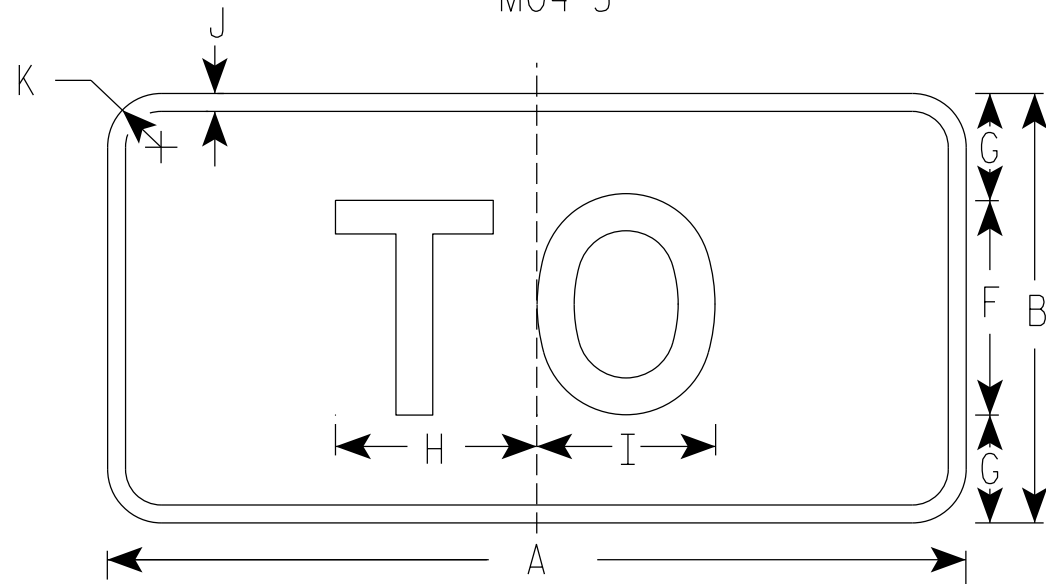

MB4-5
MK4-5
MN4-5

NOTES

1. Sign is Type II - Type H Reflective
2. Color:
Background - See note 5
Message - See note 5
3. Message Series - E
4. Corners may be square or rounded when base material is plywood but borders shall be rounded as shown. When base material is metal, the corners and borders shall be rounded.
5. M4-5 Background - White
Message - Black
MB4-5 Background - Blue
Message - White
MK4-5 Background - Green
Message - White
MM4-5 Background - White
Message - Green
MN4-5 Background - Brown
Message - White
MP4-5 Background - White
Message - Blue
M04-5 Background - Orange Type F Reflective
Message - Black

7

7

SIZE	A	B	C	D	E	F	G	H	I	J	K	L	M	N	O	P	Q	R	S	T	U	V	W	X	Y	Z	Area sq. ft.
1																											
2	24	12	1 1/8	3/8	3/8	6	3	5 3/8	5 1/4	1/2	1 1/2																2.00
3	36	18	1 3/8	3/8	1/2	9	4 1/2	8 1/4	8 3/8	1/2	1 1/2																4.5
4	36	18	1 3/8	3/8	1/2	9	4 1/2	8 1/4	8 3/8	1/2	1 1/2																4.5
5	36	18	1 3/8	3/8	1/2	9	4 1/2	8 1/4	8 3/8	1/2	1 1/2																4.5

STANDARD SIGN
M4-5

WISCONSIN DEPT OF TRANSPORTATION

APPROVED *Matthew R. Rauch*
State Traffic Engineer

DATE 03/7/19 PLATE NO. M4-5.9

PROJECT NO: _____ HWY: _____ COUNTY: _____ SHEET NO: **E**

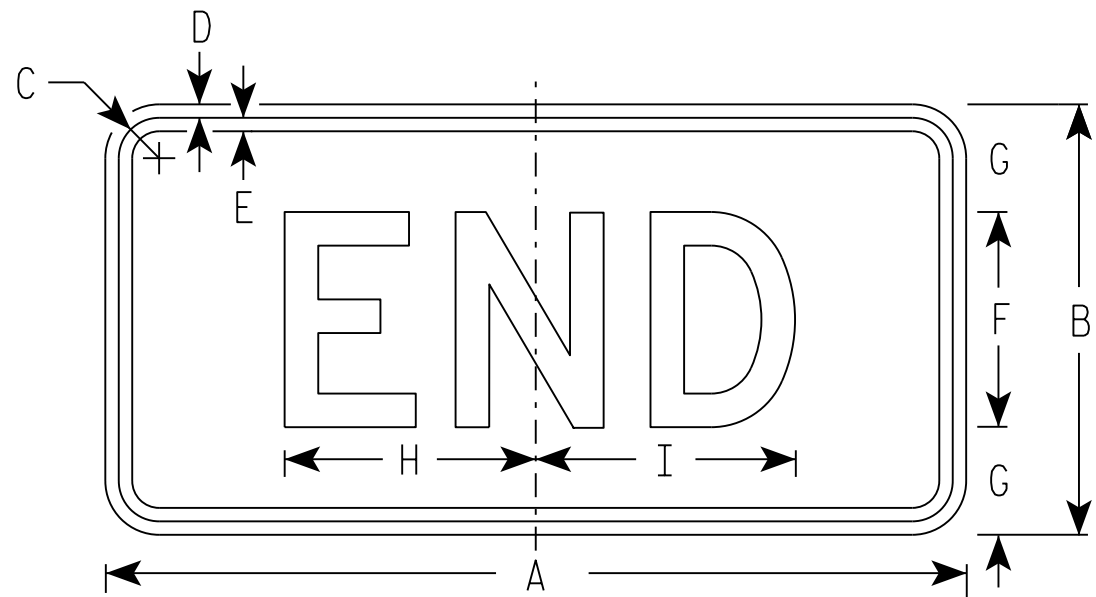

M4-6
MM4-6
MP4-6

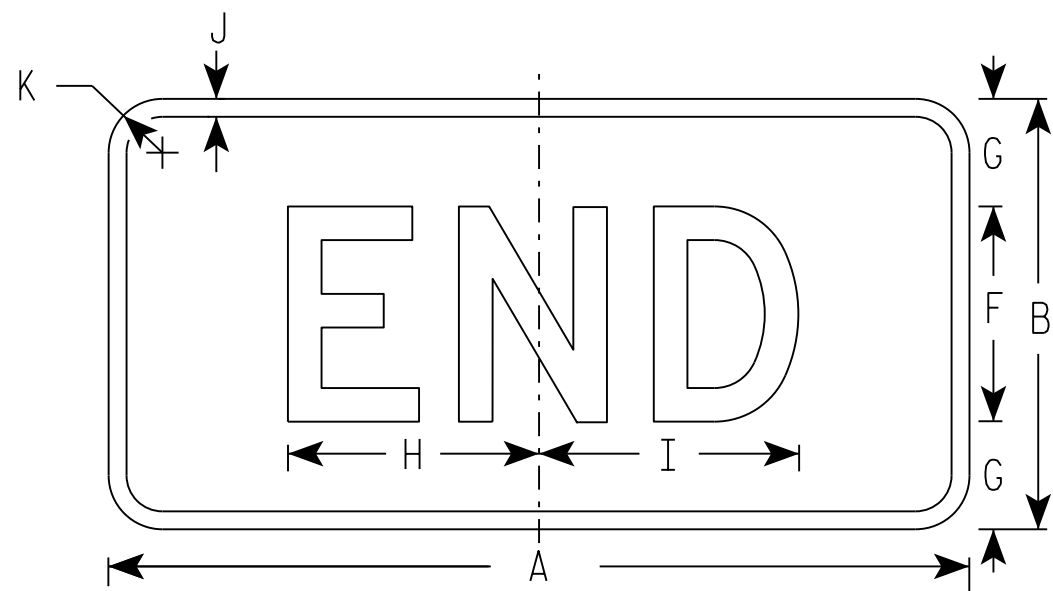

MB4-6
MK4-6
MN4-6
MR4-6

NOTES

1. Sign is Type II - Type H
2. Color:
Background - See note 5
Message - See note 5
3. Message Series - D
4. Corners may be square or rounded when base material is plywood but borders shall be rounded as shown. When base material is metal, the corners and borders shall be rounded.
5. M4-6 Background - White
Message - Black
MB4-6 Background - Blue
Message - White
MK4-6 Background - Green
Message - White
MM4-6 Background - White
Message - Green
MN4-6 Background - Brown
Message - White
MP4-6 Background - White
Message - Blue
MR4-6 Background - Brown
Message - Yellow

7

SIZE	A	B	C	D	E	F	G	H	I	J	K	L	M	N	O	P	Q	R	S	T	U	V	W	X	Y	Z	Area sq. ft.
1																											
2	24	12	1 1/8	3/8	3/8	6	3	7	7 1/4	1/2	1 1/2																2.00
3	36	18	1 1/8	3/8	1/2	9	4 1/2	12	11 7/8	1/2	1 1/2																4.5
4	36	18	1 1/8	3/8	1/2	9	4 1/2	12	11 7/8	1/2	1 1/2																4.5
5	36	18	1 1/8	3/8	1/2	9	4 1/2	12	11 7/8	1/2	1 1/2																4.5

STANDARD SIGN
M4-6

WISCONSIN DEPT OF TRANSPORTATION

APPROVED *Matthew R. Rauch*
for State Traffic Engineer

DATE 10/15/15 PLATE NO. M4-7.9

NOTES

1. Sign is Type II - Type F Reflective - reference WIS DOT Standard Specification for HIGHWAY and STRUCTURE CONSTRUCTION latest edition.
2. Color:
Background - Orange
Message - Black
3. Message Series - B
4. Corners may be square or rounded when base material is plywood but borders shall be rounded as shown. When base material is metal, the corners and borders shall be rounded.

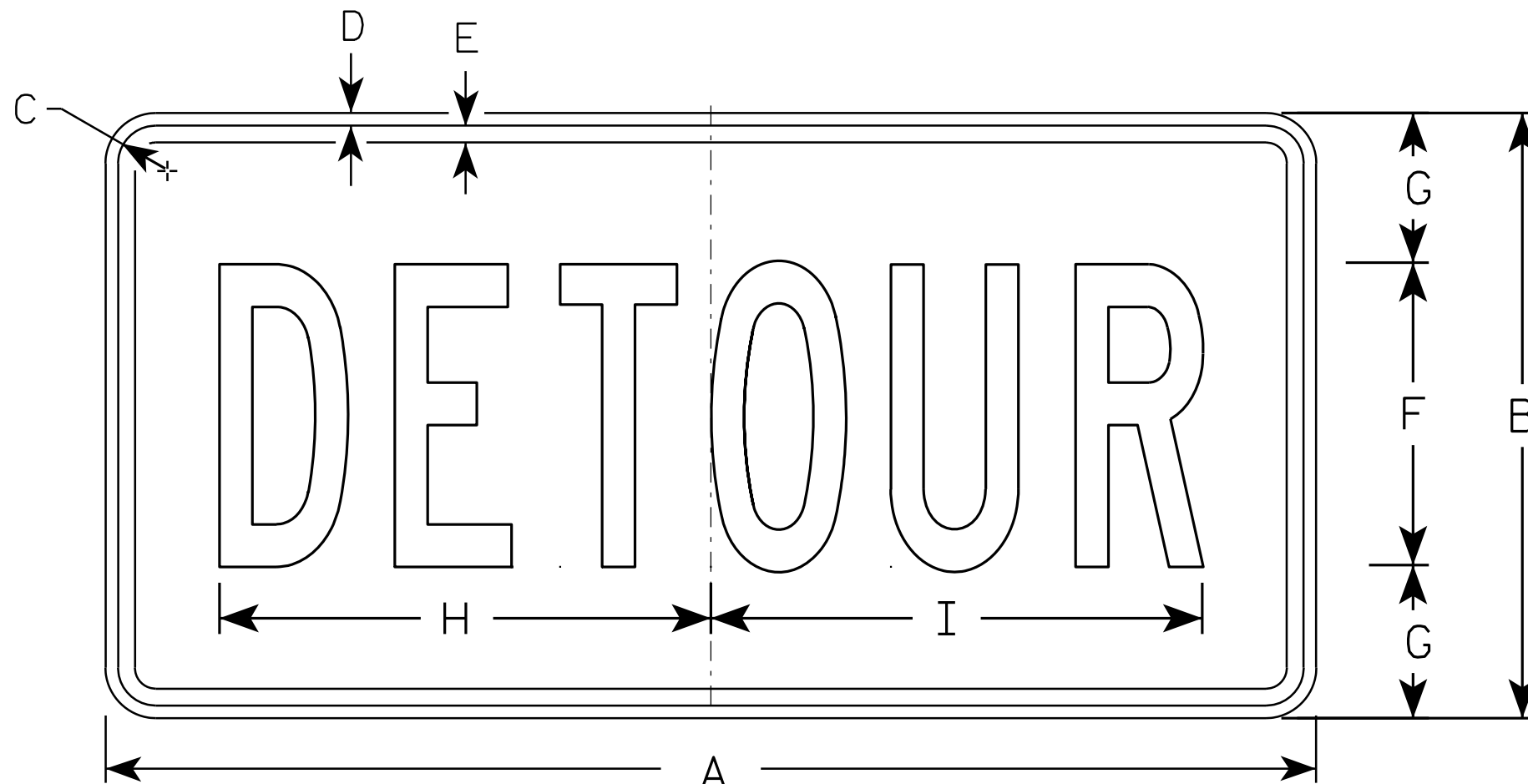

M4-8

7

7

SIZE	A	B	C	D	E	F	G	H	I	J	K	L	M	N	O	P	Q	R	S	T	U	V	W	X	Y	Z	Area sq. ft.
1																											
2	24	12	1 1/8	3/8	3/8	6	3	10	10 1/4																		2.0
3	36	18	1 1/8	3/8	1/2	9	4 1/2	14 5/8	14 1/2																		4.5
4																											
5																											

STANDARD SIGN
M4-8

WISCONSIN DEPT OF TRANSPORTATION

APPROVED *Matthew R. Rauch*
for State Traffic Engineer

DATE 11/10/10 PLATE NO. M4-8.2

PROJECT NO: _____ HWY: _____ COUNTY: _____ SHEET NO: **E**

NOTES

1. Sign is Type II - Type F Reflective - reference WIS DOT Standard Specification for HIGHWAY and STRUCTURE CONSTRUCTION latest edition.
2. Color:
Background - Orange
Message - Black
3. Message Series - B
4. Corners may be square or rounded when base material is plywood but borders shall be rounded as shown. When base material is metal, the corners and borders shall be rounded.

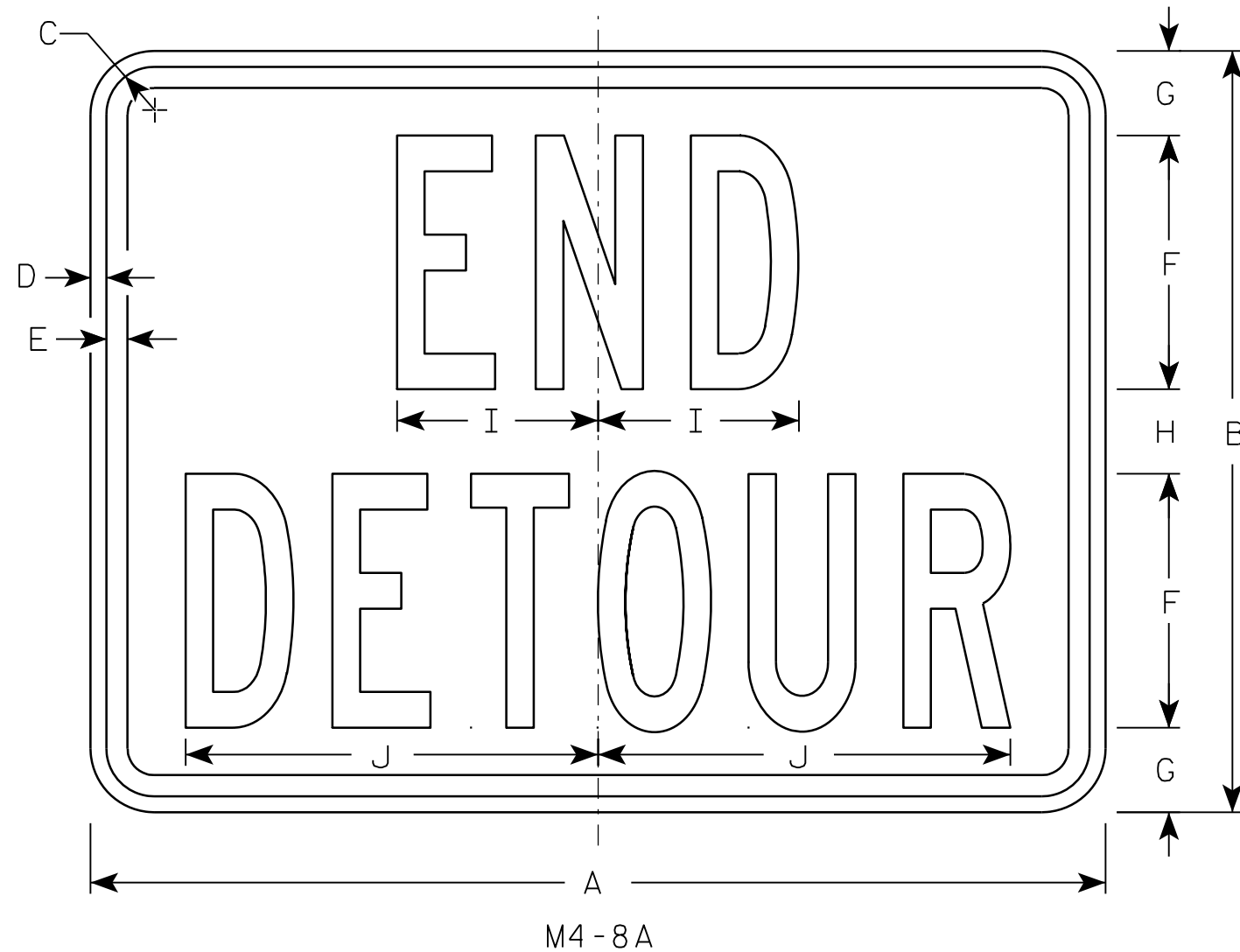

7

7

SIZE	A	B	C	D	E	F	G	H	I	J	K	L	M	N	O	P	Q	R	S	T	U	V	W	X	Y	Z	Area sq. ft.
1																											
2	24	18	1 1/8	3/8	1/2	6	2	2	4 3/4	9 3/4																	3.0
3	30	24	1 1/8	3/8	1/2	8	2 1/2	3	6 3/4	13																	5.0
4																											
5																											

STANDARD SIGN
M4-8A

WISCONSIN DEPT OF TRANSPORTATION

APPROVED *Matthew R Rauch*
for State Traffic Engineer

DATE 3/9/11 PLATE NO. M4-8A.2

PROJECT NO: _____ HWY: _____ COUNTY: _____ SHEET NO: **E**

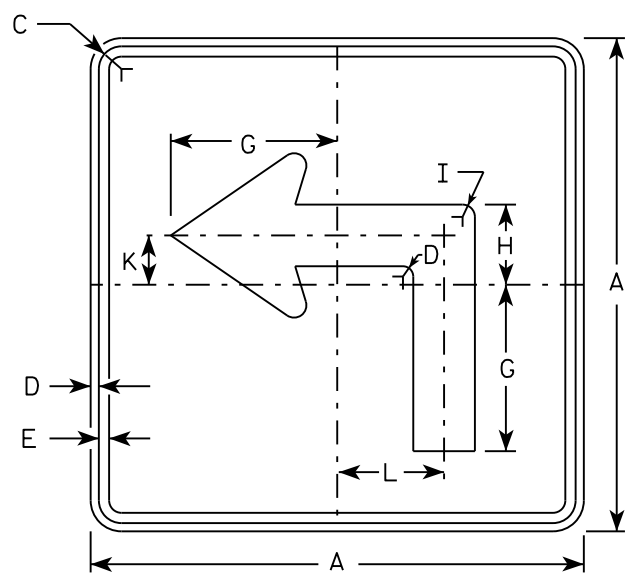

M5-1L
MM5-1L
M05-1L
MP5-1L

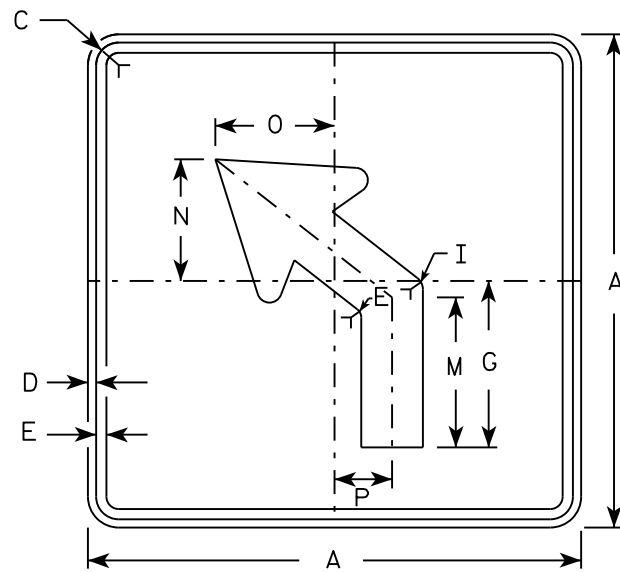

M5-2L
MM5-2L
M05-2L
MP5-2L

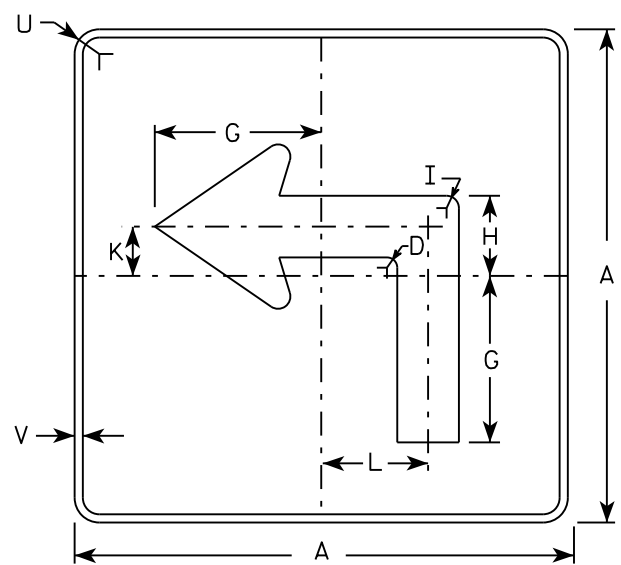

MB5-1L
MK5-1L
MN5-1L
MR5-1L

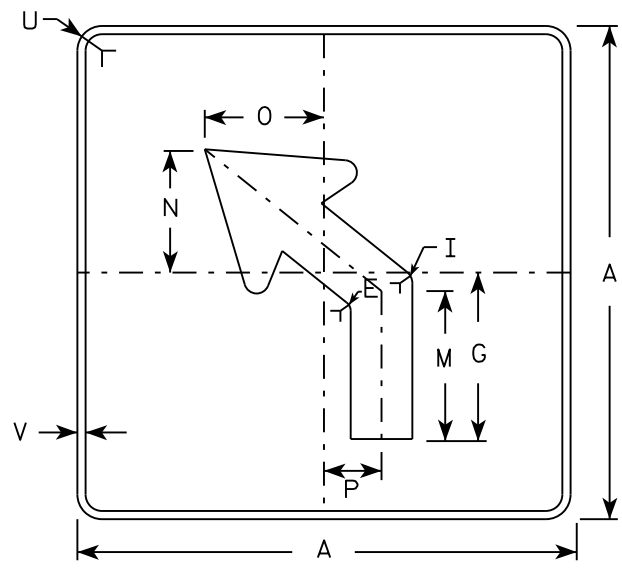

MB5-2L
MK5-2L
MN5-2L
MR5-2L

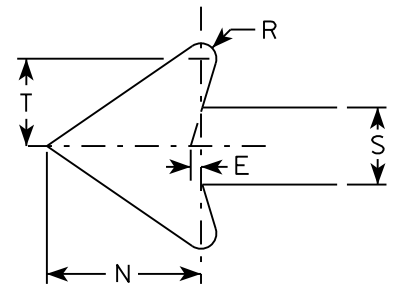

NOTES

- Signs are Type II - Type H reflective except as shown
- Color:
 - Background - See note 4
 - Message - See note 4
- Corners may be square or rounded when base material is plywood but borders shall be rounded as shown. When base material is metal, the corners and borders shall be rounded.
- M5-1 and M5-2 Background - White
Message - Black
 - MB5-1 and MB5-2 Background - Blue
Message - White
 - MK5-1 and MK5-2 Background - Green
Message - White
 - MM5-1 and MM5-2 Background - White
Message - Green
 - MN5-1 and MN5-2 Background - Brown
Message - White
 - M05-1 and M05-2 Background - Orange - Type F Reflective
Message - Black
 - MP5-1 and MP5-2 Background - White - Type H Reflective
Message - Blue
 - MR5-1 and MR5-2 Background - Brown
Message - Yellow
- M5-1R same as M5-1L except arrow points right.
- M5-2R same as M5-2L except arrow tilts right.

SIZE	A	B	C	D	E	F	G	H	I	J	K	L	M	N	O	P	Q	R	S	T	U	V	W	X	Y	Z	Area sq. ft.
1																											
2	21		1 1/8	3/8	3/8		7	3 3/8	5/8		2 1/8	4 1/2	6 3/8	5 1/4	5	2 1/2		1/2	2 5/8	3	1 1/2	1/2					3.06
3	30		1 3/8	1/2	5/8		10 1/8	4 7/8	7/8		3	6 1/2	9 1/8	7 1/2	7 1/4	3 1/2		3/4	3 3/4	4 1/4	1 7/8	1/2					6.25
4	30		1 3/8	1/2	5/8		10 1/8	4 7/8	7/8		3	6 1/2	9 1/8	7 1/2	7 1/4	3 1/2		3/4	3 3/4	4 1/4	1 7/8	1/2					6.25
5	30		1 3/8	1/2	5/8		10 1/8	4 7/8	7/8		3	6 1/2	9 1/8	7 1/2	7 1/4	3 1/2		3/4	3 3/4	4 1/4	1 7/8	1/2					6.25

STANDARD SIGN
M5-1 & M5-2

WISCONSIN DEPT OF TRANSPORTATION

APPROVED *Matthew R. Rauch*
for State Traffic Engineer

DATE 10/15/15 PLATE NO. M5-1.13

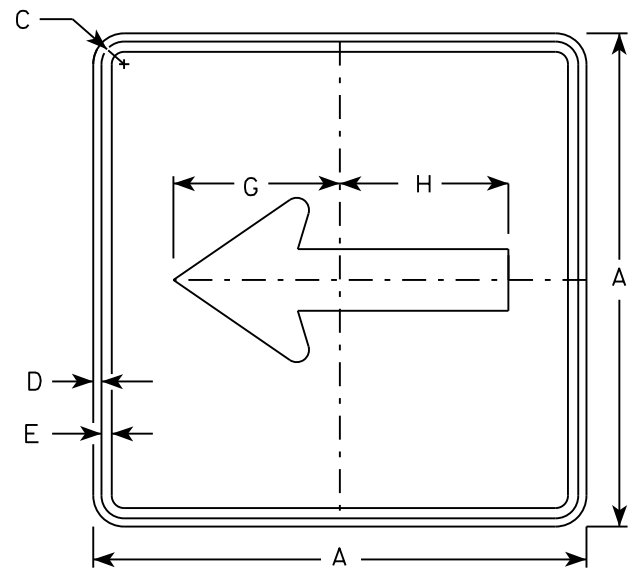

M6-1
MM6-1
M06-1
MP6-1

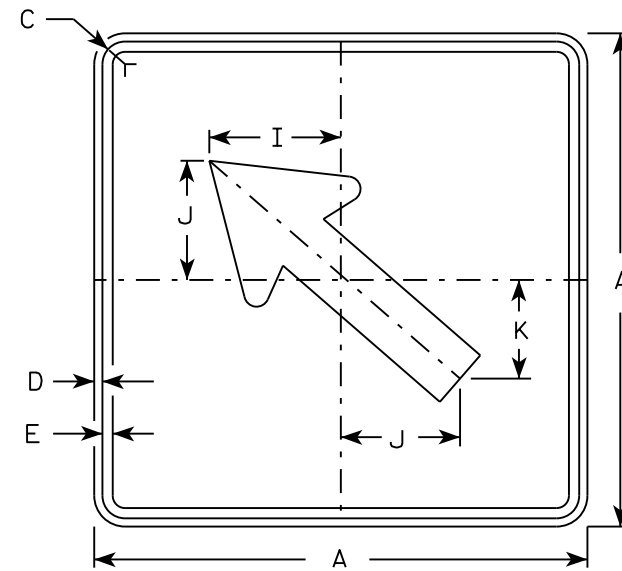

M6-2
MM6-2
M06-2
MP6-2

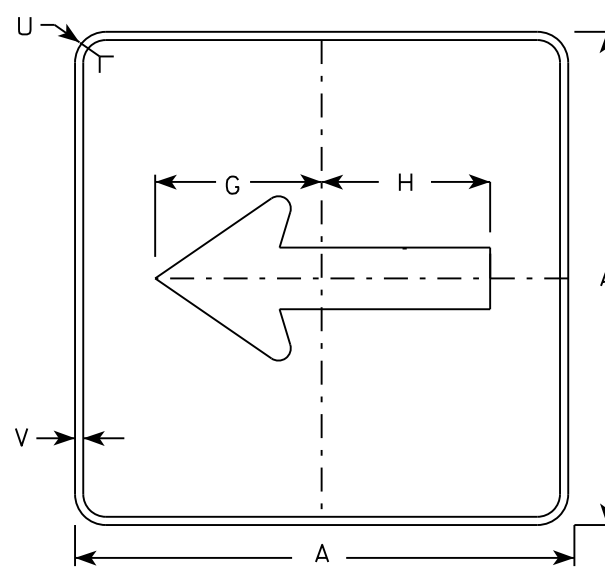

MB6-1
MK6-1
MN6-1
MR6-1

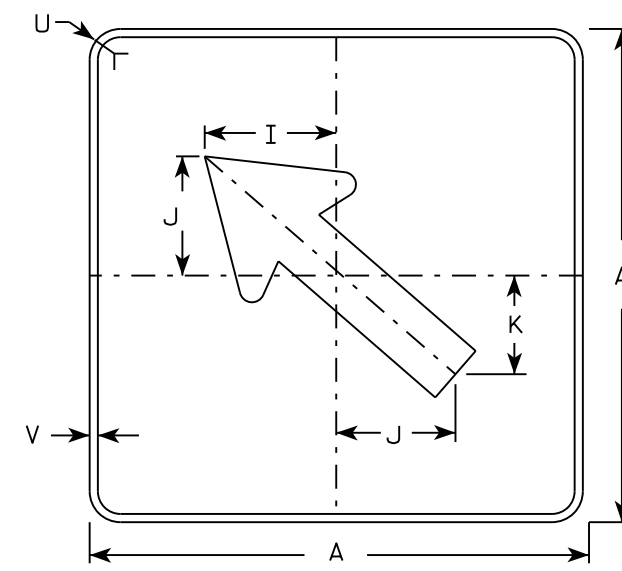

MB6-2
MK6-2
MN6-2
MR6-2

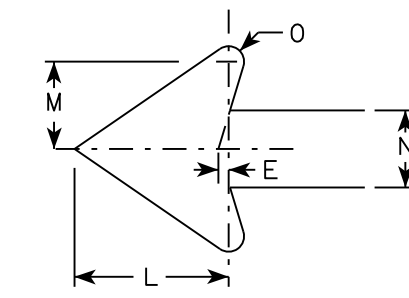

NOTES

- Signs are Type II - Type H except as Shown
- Color:
Background - See note 4
Message - See note 4
- Corners may be square or rounded when base material is plywood but borders shall be rounded as shown. When base material is metal, the corners and borders shall be rounded.
- M6-1 and M6-2 Background - White
Message - Black
MB6-1 and MB6-2 Background - Blue
Message - White
MK6-1 and MK6-2 Background - Green
Message - White
MM6-1 and MM6-2 Background - White
Message - Green
MN6-1 and MN6-2 Background - Brown
Message - White
M06-1 and M06-2 Background - Orange - Type F Reflective
Message - Black
MP6-1 and MP6-2 Background - White
Message - Blue
MR6-1 and MR6-2 Background - Brown
Message - Yellow

7

SIZE	A	B	C	D	E	F	G	H	I	J	K	L	M	N	O	P	Q	R	S	T	U	V	W	X	Y	Z	Area sq. ft.
1																											
2	21		1 1/8	3/8	3/8		7 1/2	7 1/8	5 5/8	5	4 1/4	5 1/4	3	2 5/8	1/2						1 1/2	1/2					3.06
3	30		1 3/8	1/2	5/8		10 3/4	10 1/4	8	7 1/4	6	7 1/2	4 1/4	3 3/4	3/4						1 7/8	1/2					6.25
4	30		1 3/8	1/2	5/8		10 3/4	10 1/4	8	7 1/4	6	7 1/2	4 1/4	3 3/4	3/4						1 7/8	1/2					6.25
5	30		1 3/8	1/2	5/8		10 3/4	10 1/4	8	7 1/4	6	7 1/2	4 1/4	3 3/4	3/4						1 7/8	1/2					6.25

STANDARD SIGN
M6-1 & M6-2
SERIES

WISCONSIN DEPT OF TRANSPORTATION

APPROVED *Matthew R. Rauch*
for State Traffic Engineer

DATE 10/15/15 PLATE NO. M6-1.15

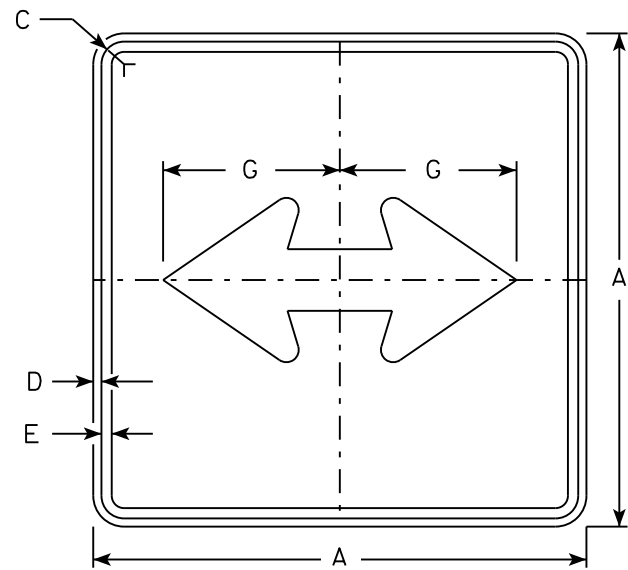

M6-4
MM6-4
M06-4
MP6-4

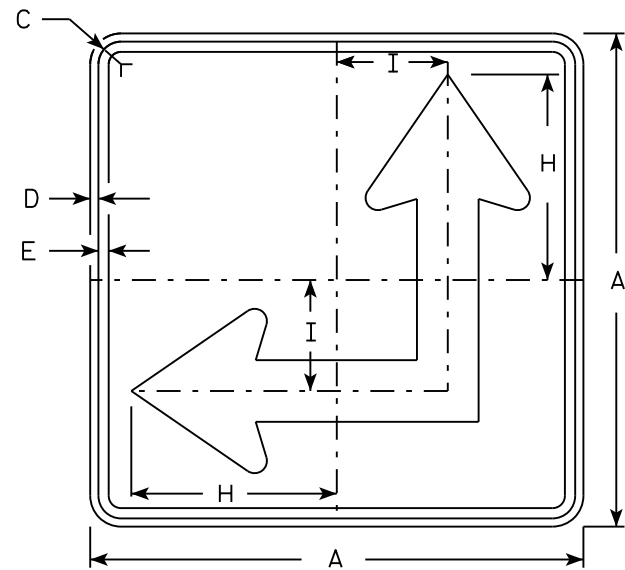

M6-6
MM6-6
M06-6
MP6-6

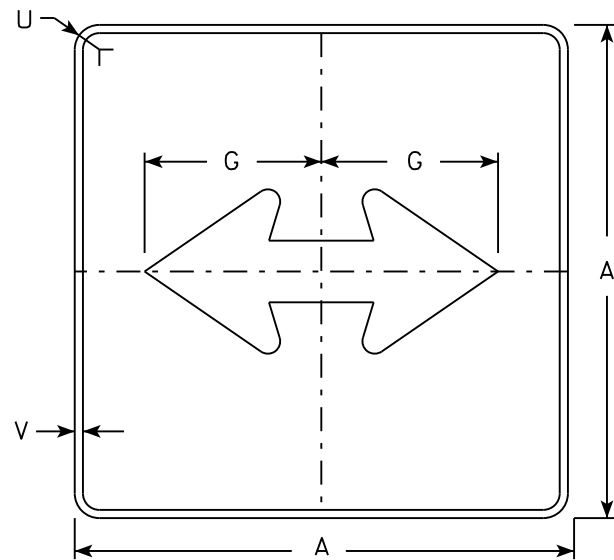

MB6-4
MK6-4
MN6-4
MR6-4

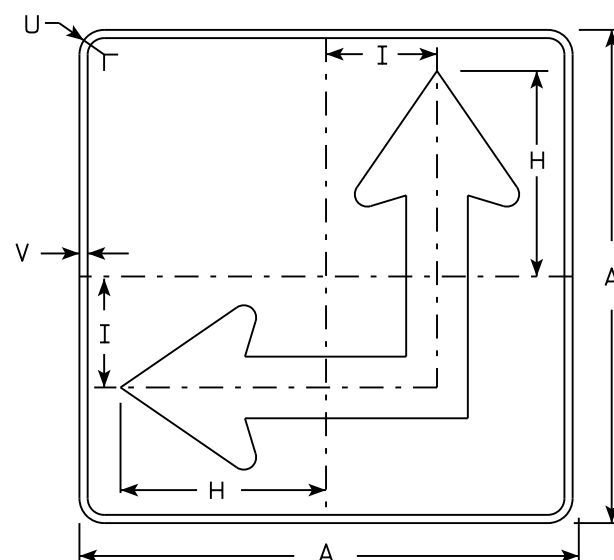

MB6-6
MK6-6
MN6-6
MR6-6

NOTES

- Signs are Type II - Type H except as Shown
- Color:
Background - See Note 4
Message - See Note 4
- Corners may be square or rounded when base material is plywood but borders shall be rounded as shown. When base material is metal, the corners and borders shall be rounded.
- M6-4 and M6-6 Background - White
Message - Black
MB6-4 and MB6-6 Background - Blue
Message - White
MK6-4 and MK6-6 Background - Green
Message - White
MM6-4 and MM6-6 Background - White
Message - Green
MN6-4 and MN6-6 Background - Brown
Message - White
M06-4 and M06-6 Background - Orange - Type F Reflective
Message - Black
MP6-4 and MP6-6 Background - White
Message - Blue
MR6-4 and MR6-6 Background - Brown
Message - Yellow
- M6-6R same as M6-6L except arrow points ahead and right.

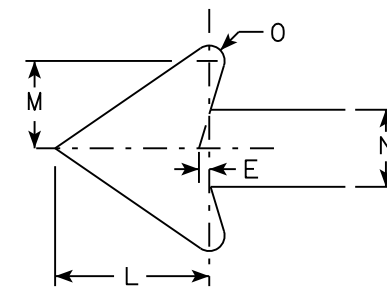

7

SIZE	A	B	C	D	E	F	G	H	I	J	K	L	M	N	O	P	Q	R	S	T	U	V	W	X	Y	Z	Area sq. ft.
1																											
2	21		1 1/8	3/8	3/8		7 1/2	8 3/4	4 1/4			5 1/4	3	2 5/8	1/2						1 1/2	1/2					3.06
3	30		1 3/8	1/2	5/8		10 3/4	12 1/2	6 3/4			7 1/2	4 1/4	3 3/4	3/4						1 7/8	1/2					6.25
4	30		1 3/8	1/2	5/8		10 3/4	12 1/2	6 3/4			7 1/2	4 1/4	3 3/4	3/4						1 7/8	1/2					6.25
5	30		1 3/8	1/2	5/8		10 3/4	12 1/2	6 3/4			7 1/2	4 1/4	3 3/4	3/4						1 7/8	1/2					6.25

STANDARD SIGN
M6-4 & M6-6
SERIES

WISCONSIN DEPT OF TRANSPORTATION

APPROVED *Matthew R. Rauch*
for State Traffic Engineer

DATE 10/15/15 PLATE NO. M6-4.10

NOTES

1. Sign is Type II - Type H Reflective - reference WIS DOT Standard Specification for HIGHWAY and STRUCTURE CONSTRUCTION latest edition.
2. Color:
Background - Red
Message - White
3. Message Series - C

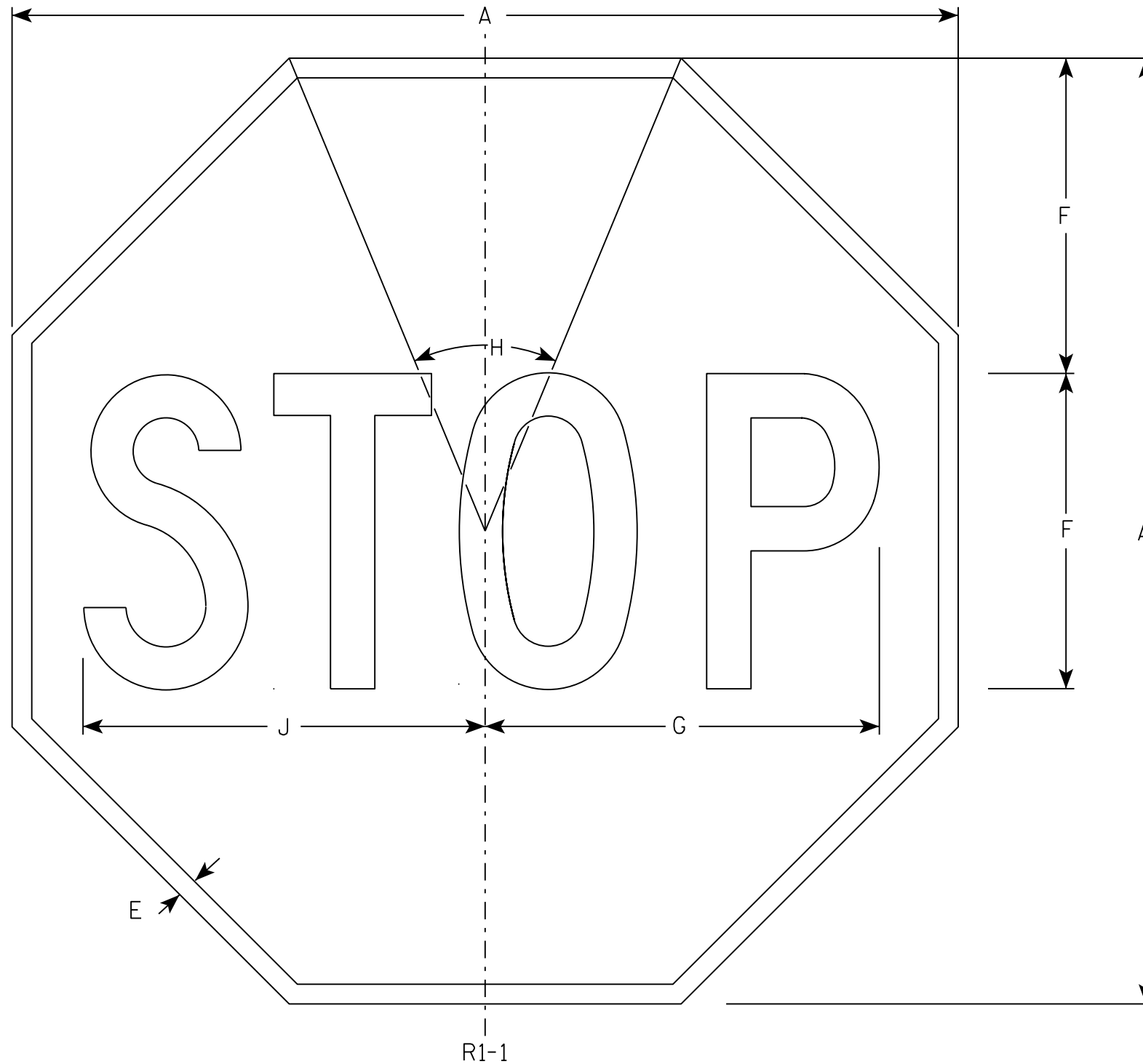

R1-1

SIZE	A	B	C	D	E	F	G	H	I	J	K	L	M	N	O	P	Q	R	S	T	U	V	W	X	Y	Z	Area sq. ft.
1	30				5/8	10	12 1/2	45°		12 3/4																	5.18
2S	30				5/8	10	12 1/2	45°		12 3/4																	5.18
2M	36				3/4	12	15	45°		15 3/8																	7.46
3	36				3/4	12	15	45°		15 3/8																	7.46
4	48				1	16	20	45°		20 1/2																	13.25
5	48				1	16	20	45°		20 1/2																	13.25
6	18				3/8	6	7 3/4	45°		7 3/4																	1.86
7	12				1/4	4	5	45°		5 1/8																	0.78

STANDARD SIGN
R1-1

WISCONSIN DEPT OF TRANSPORTATION

APPROVED *Matthew R. Rauch*
for State Traffic Engineer

DATE 11/12/15 PLATE NO. R1-1.13

PROJECT NO: _____ HWY: _____ COUNTY: _____ SHEET NO: **E**

NOTES

1. Sign is Type II - Type H Reflective - reference WIS DOT Standard Specification for HIGHWAY and STRUCTURE CONSTRUCTION latest edition.
2. Color:
Background - White
Message - Black
3. Message Series - C
4. Corners may be square or rounded when base material is plywood but borders shall be rounded as shown. When base material is metal, the corners and borders shall be rounded.

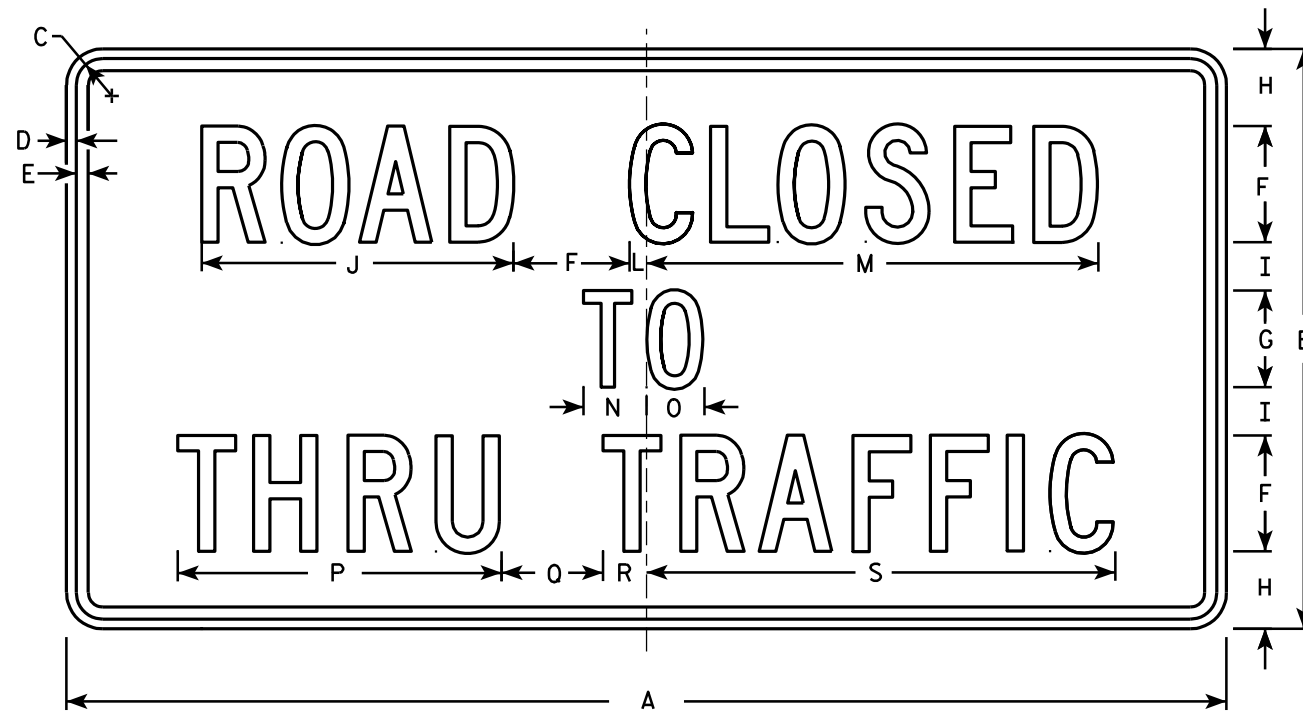

R11-4

7

7

SIZE	A	B	C	D	E	F	G	H	I	J	K	L	M	N	O	P	Q	R	S	T	U	V	W	X	Y	Z	Area sq. ft.
1																											
2S	60	30	1 3/8	1/2	5/8	6	5	4	2 1/2	16 1/8		7/8	23 3/8	3 1/4	3	16 3/4	5 1/4	2 1/4	24 1/4								12.5
2M	60	30	1 3/8	1/2	5/8	6	5	4	2 1/2	16 1/8		7/8	23 3/8	3 1/4	3	16 3/4	5 1/4	2 1/4	24 1/4								12.5
3																											
4																											
5																											

STANDARD SIGN
R11 - 4

WISCONSIN DEPT OF TRANSPORTATION

APPROVED *Matthew R. Raush*
for State Traffic Engineer

DATE 4/1/11 PLATE NO. R11-4.3

PROJECT NO: _____ HWY: _____ COUNTY: _____ SHEET NO: _____ E

NOTES

1. Sign is Type II - Type F Reflective - reference WIS DOT Standard Specification for HIGHWAY and STRUCTURE CONSTRUCTION latest edition.
2. Color:
Background - Yellow
Message - Black
3. Corners may be square or rounded when base material is plywood but borders shall be rounded as shown. When base material is metal, the corners and borders shall be rounded.
4. W1-2L is the same as W1-2R except the arrow is reversed along the vertical centerline.

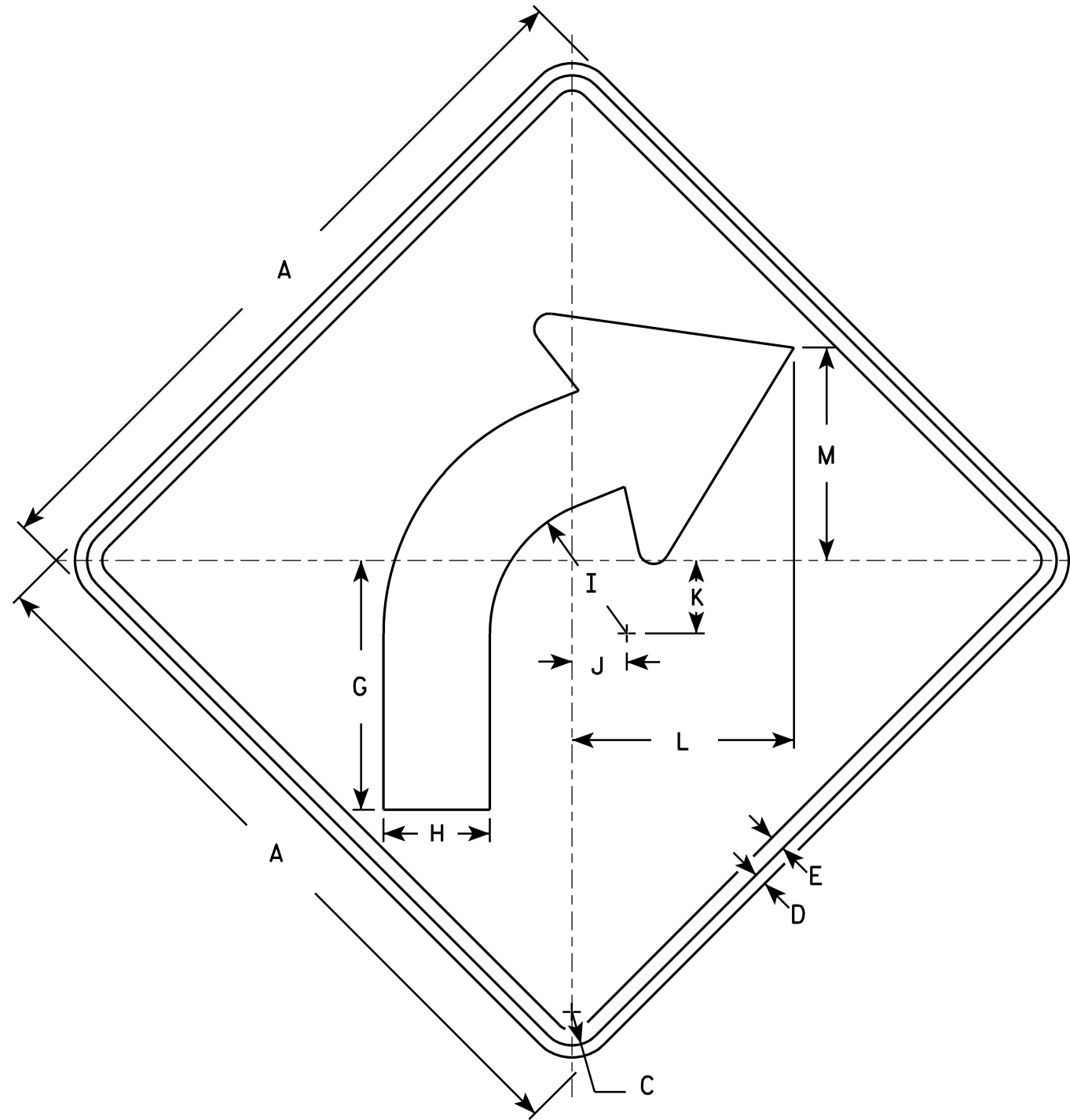

W1-2R

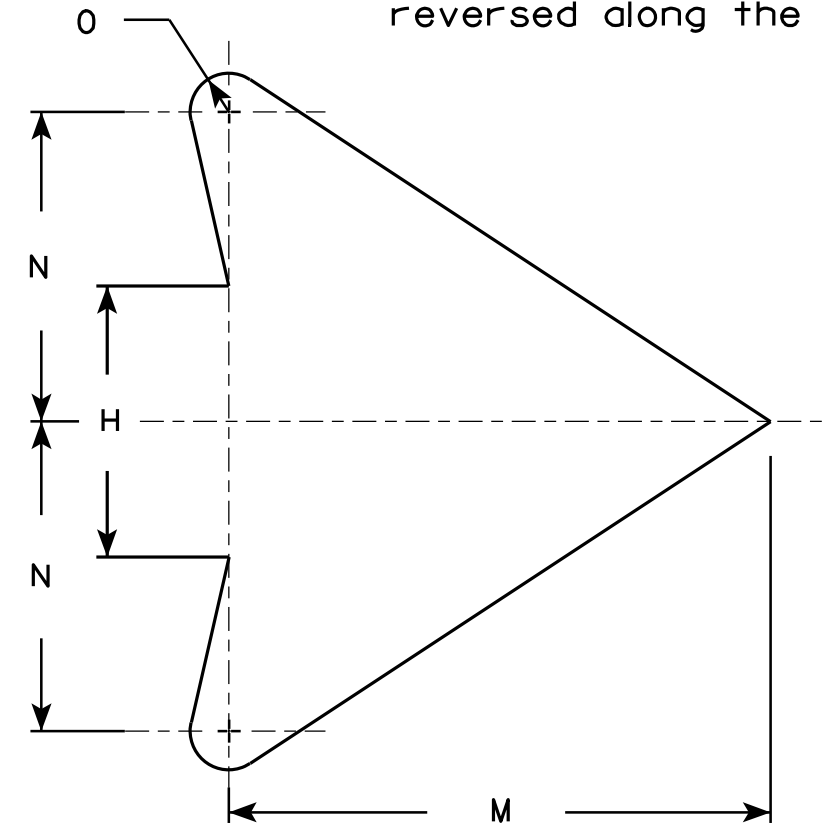

ARROW DETAIL

SIZE	A	B	C	D	E	F	G	H	I	J	K	L	M	N	O	P	Q	R	S	T	U	V	W	X	Y	Z	Area sq. ft.
1	24		1 1/8	3/8	1/2		8 1/4	3 1/2	4 1/2	1 3/4	2 3/8	7 1/4	7	4	1/2												4.0
2S	30		1 3/8	1/2	5/8		10 1/4	4 3/8	5 5/8	2 1/4	3	9 1/8	8 3/4	5	5/8												6.25
2M	36		1 5/8	5/8	3/4		12 3/8	5 1/4	6 3/4	2 5/8	3 1/2	10 7/8	10 1/2	6	3/4												9.0
3	36		1 5/8	5/8	3/4		12 3/8	5 1/4	6 3/4	2 5/8	3 1/2	10 7/8	10 1/2	6	3/4												9.0
4	36		1 5/8	5/8	3/4		12 3/8	5 1/4	6 3/4	2 5/8	3 1/2	10 7/8	10 1/2	6	3/4												9.0
5	48		2 1/4	3/4	1		16 1/2	7	9	3 1/2	4 5/8	14 1/2	14	8	1												16.0

STANDARD SIGN
W1-2

WISCONSIN DEPT OF TRANSPORTATION

APPROVED *Matthew R. Rauch*
For State Traffic Engineer

DATE 5/15/12 PLATE NO. W1-2.10

PROJECT NO: _____ HWY: _____ COUNTY: _____ SHEET NO: **E**

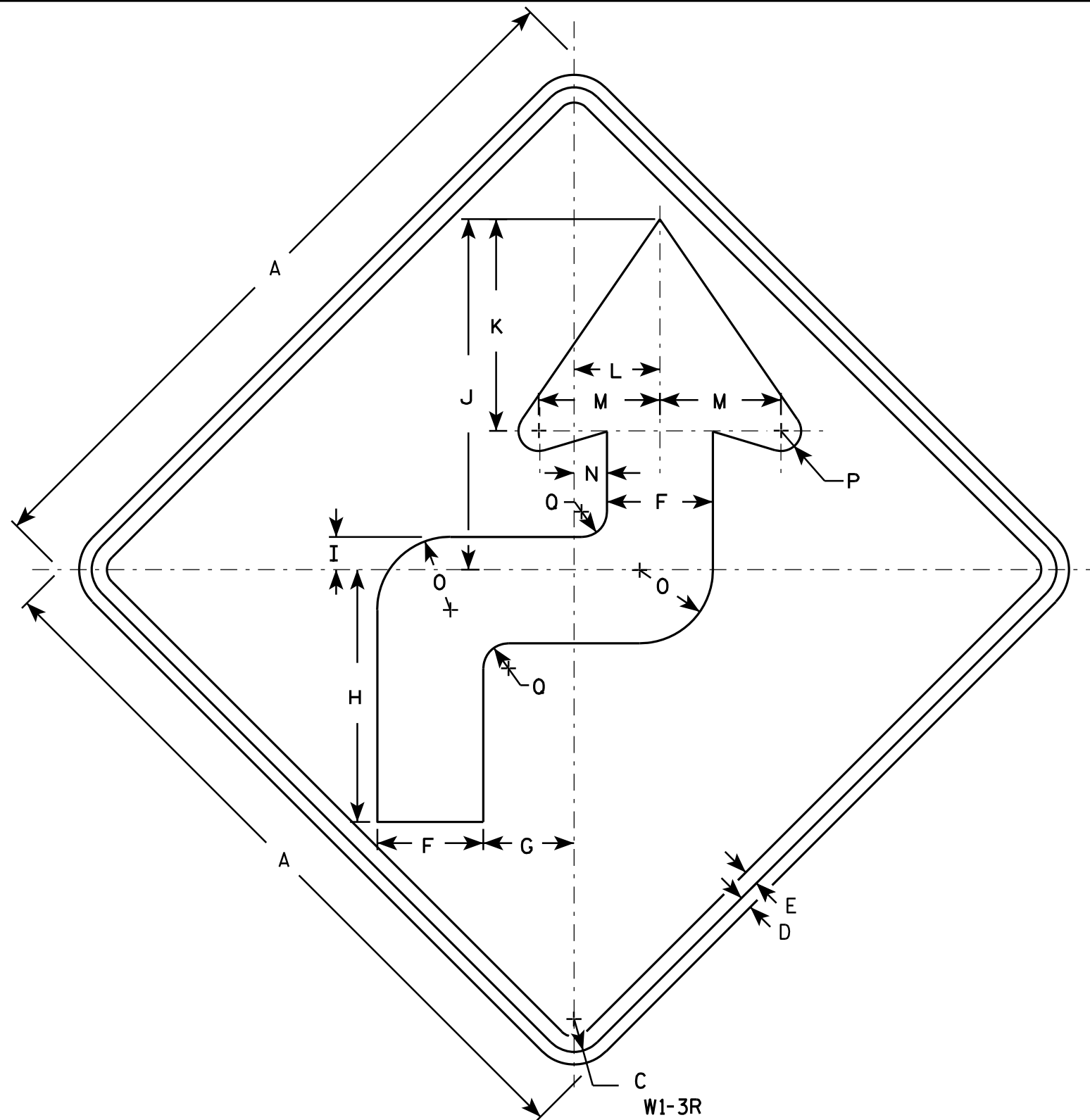

NOTES

1. Sign is Type II - Type F Reflective - reference WIS DOT Standard Specification for HIGHWAY and STRUCTURE CONSTRUCTION latest edition.
2. Color:
Background - Yellow
Message - Black
3. Corners may be square or rounded when base material is plywood but borders shall be rounded as shown. When base material is metal, the corners and borders shall be rounded.
4. W1-3L is the same as W1-3R except the arrow is reversed along the vertical centerline.

7

7

W1-3R

SIZE	A	B	C	D	E	F	G	H	I	J	K	L	M	N	O	P	Q	R	S	T	U	V	W	X	Y	Z	Area sq. ft.
1	24		1 1/8	3/8	1/2	3 1/2	3	8 3/8	1 1/8	11 5/8	7	2 3/4	4	1 1/8	2 1/2	5/8	7/8										4.0
2S	36		1 5/8	5/8	3/4	5 1/4	4 1/2	12 1/2	1 5/8	17 3/8	10 1/2	4 1/4	6	1 5/8	3 5/8	1	1 1/4										9.0
2M	36		1 5/8	5/8	3/4	5 1/4	4 1/2	12 1/2	1 5/8	17 3/8	10 1/2	4 1/4	6	1 5/8	3 5/8	1	1 1/4										9.0
3	36		1 5/8	5/8	3/4	5 1/4	4 1/2	12 1/2	1 5/8	17 3/8	10 1/2	4 1/4	6	1 5/8	3 5/8	1	1 1/4										9.0
4	36		1 5/8	5/8	3/4	5 1/4	6	12 1/2	1 5/8	17 3/8	10 1/2	4 1/4	6	1 5/8	3 5/8	1	1 1/4										9.0
5	48		2 1/4	3/4	1	7	6	16 5/8	2 1/4	23 1/4	14	5 5/8	8	2 1/8	4 7/8	1 1/4	1 5/8										16.0

STANDARD SIGN
W1-3

WISCONSIN DEPT OF TRANSPORTATION

APPROVED *Matthew R. Rauch*
for State Traffic Engineer

DATE 5/17/12 PLATE NO. W1-3.8

PROJECT NO: _____ HWY: _____ COUNTY: _____ SHEET NO: **E**

NOTES

1. Sign is Type II - Type F Reflective - reference WIS DOT Standard Specification for HIGHWAY and STRUCTURE CONSTRUCTION latest edition.
2. Color:
Background - Yellow
Message - Black
3. Corners may be square or rounded when base material is plywood but borders shall be rounded as shown. When base material is metal, the corners and borders shall be rounded.

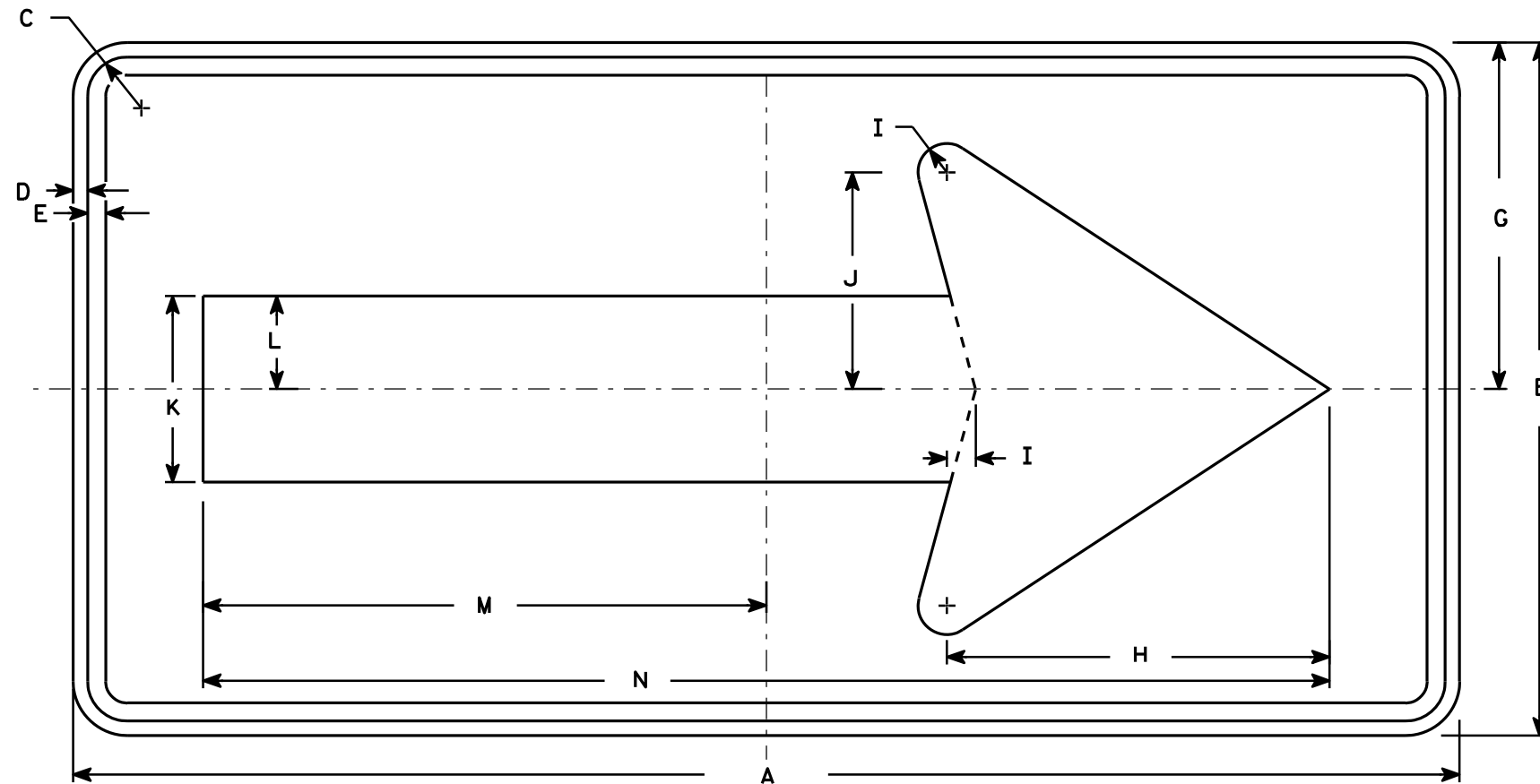

W1-6

7

7

SIZE	A	B	C	D	E	F	G	H	I	J	K	L	M	N	O	P	Q	R	S	T	U	V	W	X	Y	Z	Area sq. ft.
1	36	18	1 1/8	3/8	3/8		9	10	3/4	5 5/8	4 3/4	2 3/8	14 5/8	29 1/4													4.5
2S	48	24	1 3/8	1/2	5/8		12	13 1/4	1	7 1/2	6 1/2	3 1/4	19 1/2	39													8.0
2M	48	24	1 3/8	1/2	5/8		12	13 1/4	1	7 1/2	6 1/2	3 1/4	19 1/2	39													8.0
3	60	30	1 3/8	1/2	5/8		15	16 1/4	1 1/4	9 1/4	8	4	24 3/8	48 3/4													12.5
4	60	30	1 3/8	1/2	5/8		15	16 1/4	1 1/4	9 1/4	8	4	24 3/8	48 3/4													12.5
5	96	48	2 1/4	3/4	1		24	26 1/2	2	15	13	6 1/2	39	78													32.0

STANDARD SIGN
W1-6

WISCONSIN DEPT OF TRANSPORTATION

APPROVED *Matthew R. Rauch*
For State Traffic Engineer

DATE 6/7/10 PLATE NO. W1-6.8

PROJECT NO: _____ HWY: _____ COUNTY: _____ SHEET NO: _____

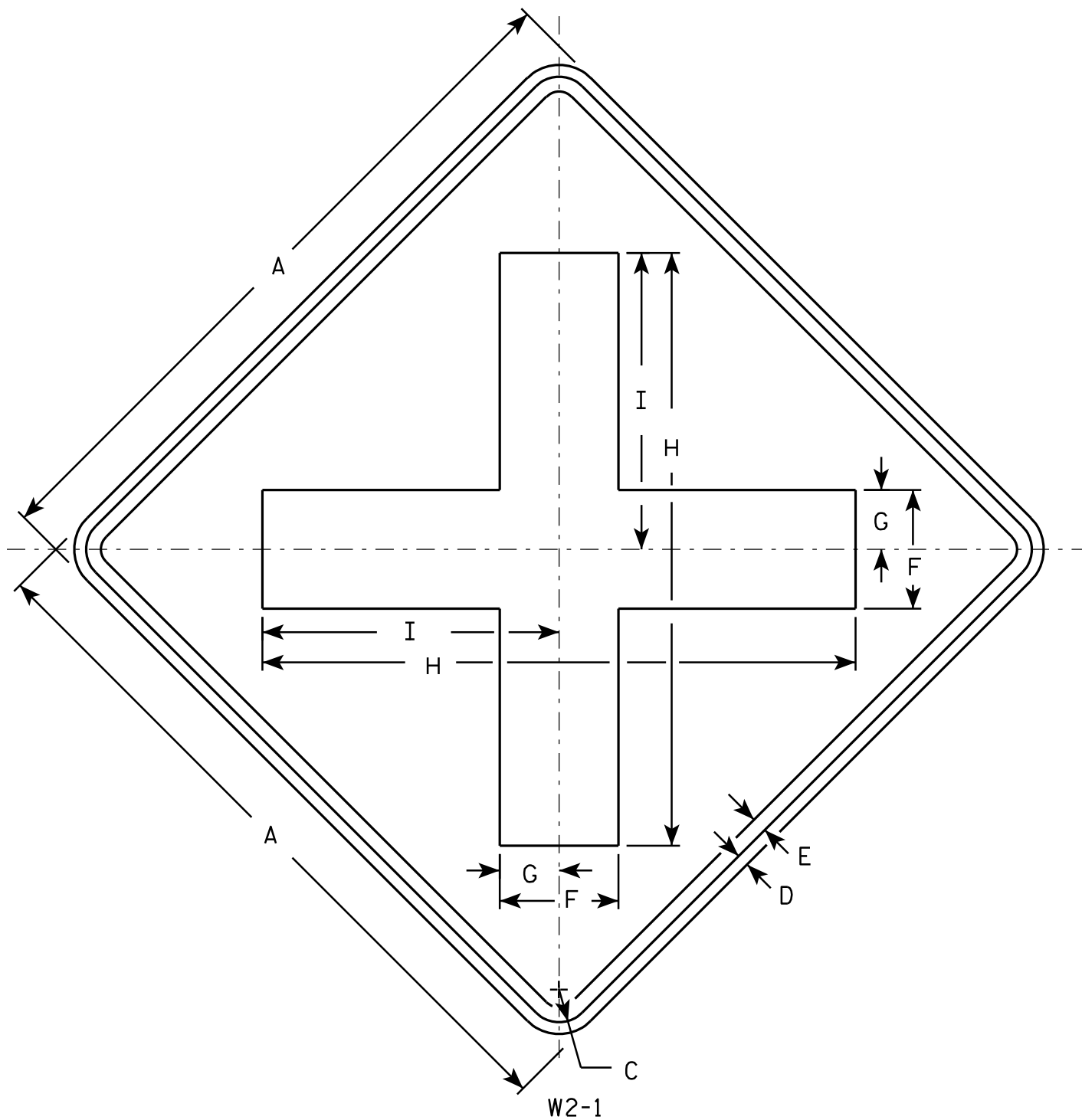

NOTES

1. Sign is Type II - Type F Reflective - reference WIS DOT Standard Specification for HIGHWAY and STRUCTURE CONSTRUCTION latest edition.
2. Color:
 Background - Yellow
 Message - Black
3. Corners may be square or rounded when base material is plywood but borders shall be rounded as shown. When base material is metal, the corners and borders shall be rounded.

7

7

SIZE	A	B	C	D	E	F	G	H	I	J	K	L	M	N	O	P	Q	R	S	T	U	V	W	X	Y	Z	Area sq. ft.
1	24		1 1/8	3/8	1/2	4	2	20	10																		4.0
2S	30		1 3/8	1/2	5/8	5	2 1/2	25	12 1/2																		6.25
2M	30		1 3/8	1/2	5/8	5	2 1/2	25	12 1/2																		6.25
3	36		1 5/8	5/8	3/4	6	3	30	15																		9.0
4	48		2 1/4	3/4	1	8	4	40	20																		16.0
5																											

STANDARD SIGN
W2-1

WISCONSIN DEPT OF TRANSPORTATION

APPROVED *Matthew R. Rauch*
for State Traffic Engineer

DATE 5/29/12 PLATE NO. W2-1.9

PROJECT NO: _____ HWY: _____ COUNTY: _____ SHEET NO: _____ E

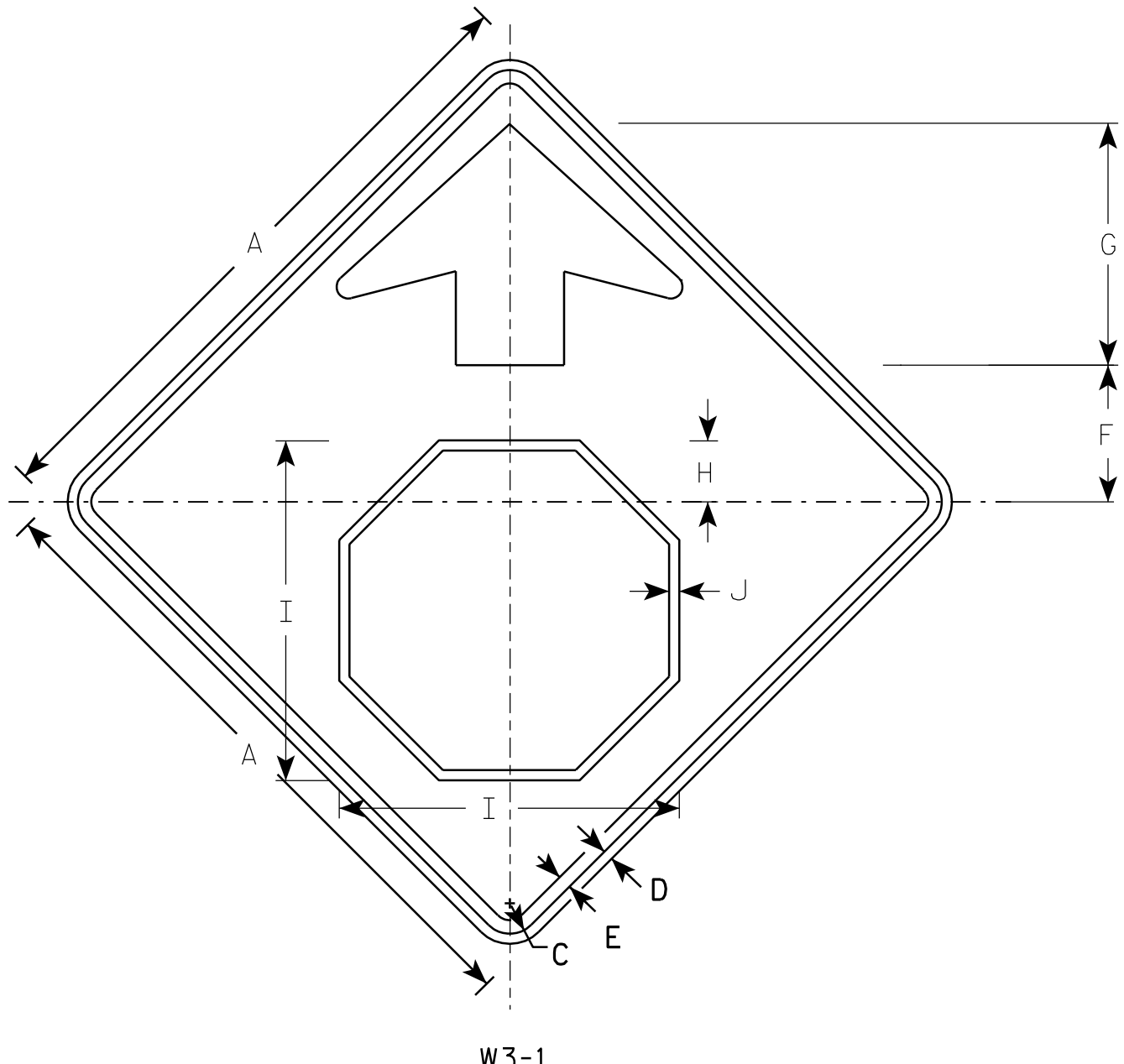

W3-1

NOTES

1. All Signs Type II - Type F Reflective - reference WIS DOT Standard Specification for HIGHWAY and STRUCTURE CONSTRUCTION latest edition.
2. Color:
 Background - YELLOW
 Arrow & Border - BLACK
 Stop Symbol - WHITE BORDER ON RED BACKGROUND

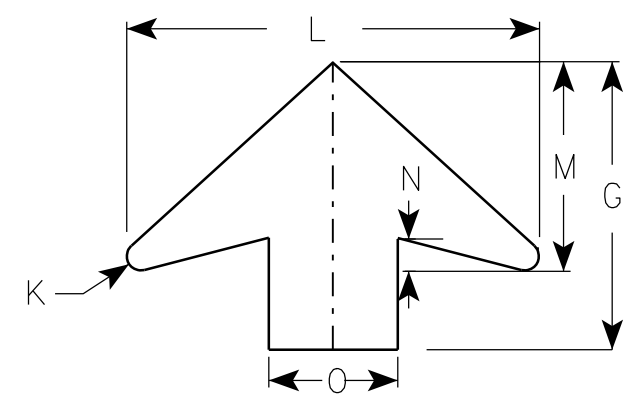

ARROW DETAIL

7

7

SIZE	A	B	C	D	E	F	G	H	I	J	K	L	M	N	O	P	Q	R	S	T	U	V	W	X	Y	Z	Area sq. ft.
1	30		1 3/8	1/2	5/8	6 1/4	11 1/4	2 7/8	15 3/4	1/2	1/2	16	8	1 1/4	5												6.25
2S	36		1 5/8	5/8	3/4	7 1/2	13 1/2	3 1/2	19	5/8	5/8	19 1/4	9 3/4	1 5/8	6												9.0
2M	36		1 5/8	5/8	3/4	7 1/2	13 1/2	3 1/2	19	5/8	5/8	19 1/4	9 3/4	1 5/8	6												9.0
3	36		1 5/8	5/8	3/4	7 1/2	13 1/2	3 1/2	19	5/8	5/8	19 1/4	9 3/4	1 5/8	6												9.0
4	48		2 1/4	3/4	1	10	17 7/8	4 1/2	25 1/8	3/4	7/8	25 5/8	13	2	8												16.0
5	48		2 1/4	3/4	1	10	17 7/8	4 1/2	25 1/8	3/4	7/8	25 5/8	13	2	8												16.0

STANDARD SIGN
W3-1

WISCONSIN DEPT OF TRANSPORTATION

APPROVED *Matthew R. Rauch*
for State Traffic Engineer

DATE 6/7/10 PLATE NO. W3-1.12

PROJECT NO: _____ SHEET NO: _____ E

NOTES

1. Sign is Type II - Type F Reflective - reference WIS DOT Standard Specification for HIGHWAY and STRUCTURE CONSTRUCTION latest edition.
2. Color:
Background - Yellow
Message - Black
3. Message Series - B
4. Corners may be square or rounded when base material is plywood but borders shall be rounded as shown. When base material is metal, the corners and borders shall be rounded.



W4-4B

7

7

SIZE	A	B	C	D	E	F	G	H	I	J	K	L	M	N	O	P	Q	R	S	T	U	V	W	X	Y	Z	Area sq. ft.
1																											
2S	30	12	1 1/8	3/8	1/2	3	2 1/4	1 1/2	12 3/8	5/8	1 1/2	10 3/8	6 1/4	2 1/4	2 1/4	6 1/4											2.5
2M	30	12	1 1/8	3/8	1/2	3	2 1/4	1 1/2	12 3/8	5/8	1 1/2	10 3/8	6 1/4	2 1/4	2 1/4	6 1/4											2.5
3	42	15	1 1/8	3/8	1/2	4	2 5/8	1 3/4	16 7/8	5/8	2 3/8	13 7/8	8 3/8	3	3 1/8	8 3/8											4.17
4	48	18	1 1/8	3/8	1/2	5	3	2	21	5/8	3 1/8	17 1/4	10 1/2	3 5/8	3 7/8	10 3/8											6.0
5																											

STANDARD SIGN
W4-4B

WISCONSIN DEPT OF TRANSPORTATION

APPROVED *Matthew R. Rauch*
for State Traffic Engineer

DATE 03/12/13 PLATE NO. W4-4B.2

PROJECT NO: _____ HWY: _____ COUNTY: _____ SHEET NO: _____ E

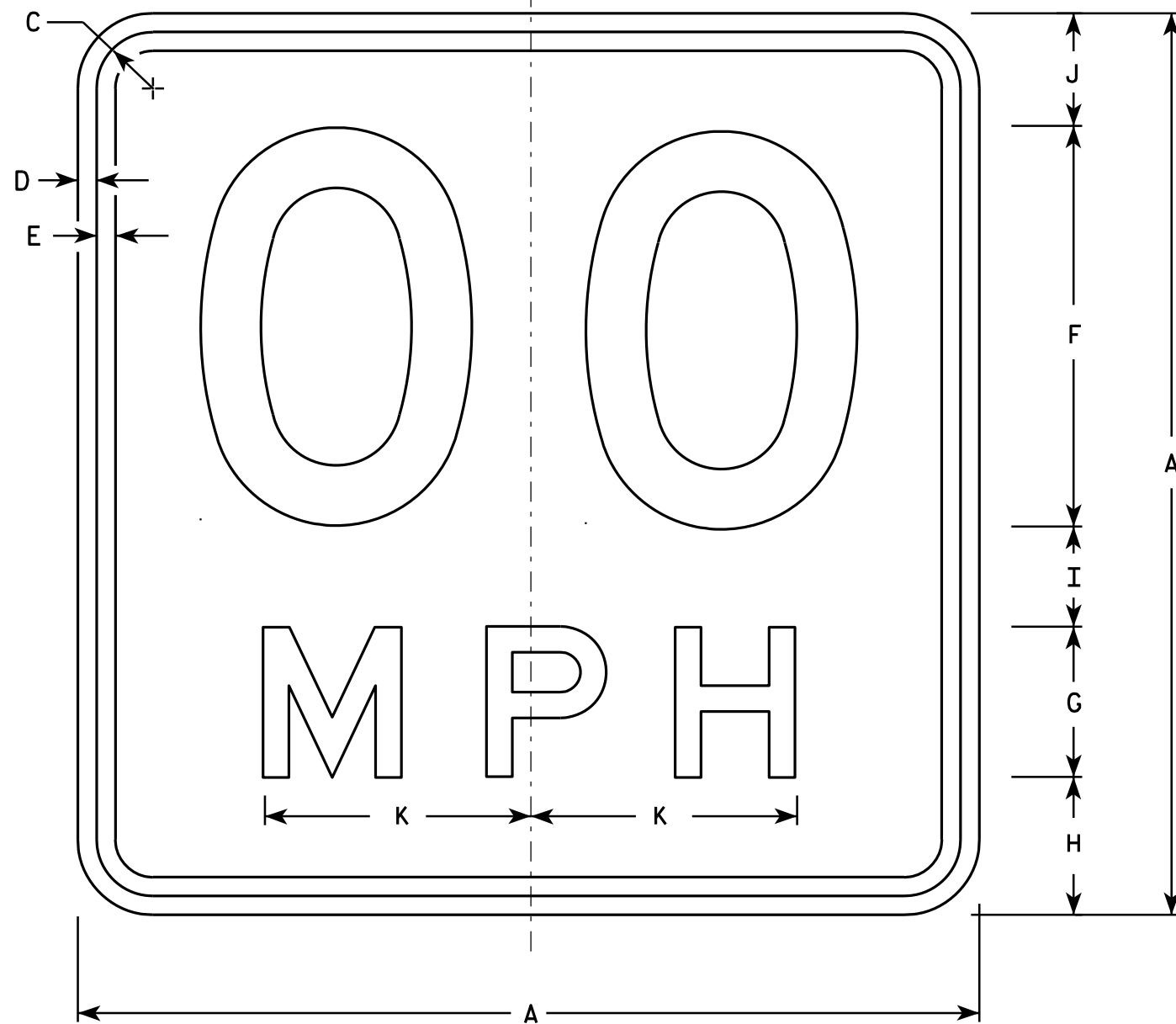

NOTES

1. Sign is Type II - Type F Reflective - reference WIS DOT Standard Specification for HIGHWAY and STRUCTURE CONSTRUCTION latest edition.
2. Color:
Background - Yellow
Message - Black
3. Message Series - See Note 6
4. Corners may be square or rounded when base material is plywood but borders shall be rounded as shown. When base material is metal, the corners and borders shall be rounded.
5. Substitute appropriate numerals and optically space about centerline to achieve proper balance.
6. Line 1 is Series D
Line 2 is Series E

W13-1

* For 30" x 30" Warning Signs, use 18" x 18" W13-1 signs.
For 36" x 36" Warning Signs, use 24" x 24" W13-1 signs.

SIZE	A	B	C	D	E	F	G	H	I	J	K	L	M	N	O	P	Q	R	S	T	U	V	W	X	Y	Z	Area sq. ft.
1	18		1 1/8	3/8	3/8	8	3	2 3/4	2	2 1/4	5 3/8																2.25
* 2S	18		1 1/8	3/8	3/8	8	3	2 3/4	2	2 1/4	5 3/8																2.25
* 2M	18		1 1/8	3/8	3/8	8	3	2 3/4	2	2 1/4	5 3/8																2.25
3	24		1 1/8	3/8	1/2	10	4	4	2 3/4	3 1/4	6 5/8																4.00
4	36		1 5/8	5/8	3/4	16	6	5 1/2	4	4 1/2	10 5/8																9.00
5	36		1 5/8	5/8	3/4	16	6	5 1/2	4	4 1/2	10 5/8																9.00

STANDARD SIGN

W13-1

WISCONSIN DEPT OF TRANSPORTATION

APPROVED *Matthew R. Rauch*
For State Traffic Engineer

DATE 5/31/12 PLATE NO. W13-1.16

PROJECT NO:

HWY:

COUNTY:

SHEET NO:

E

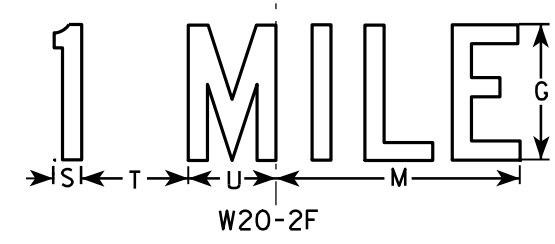
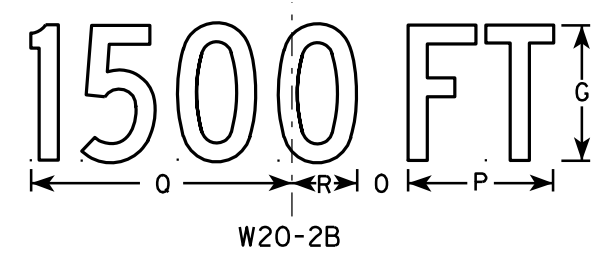
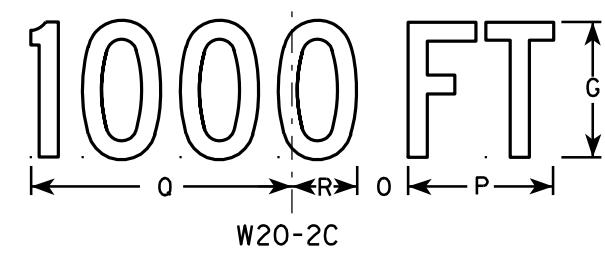
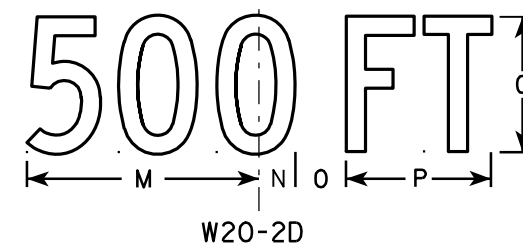
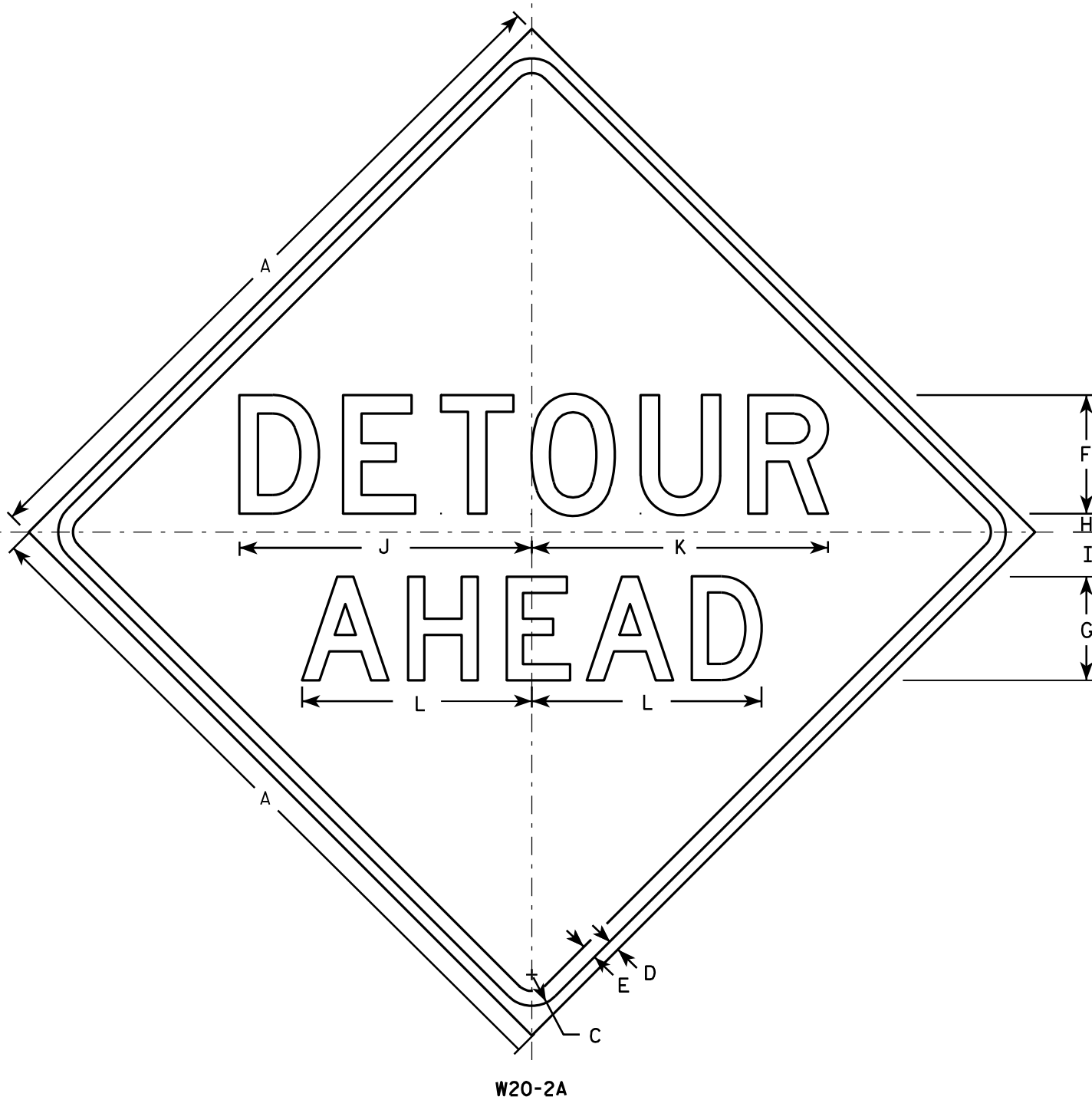

NOTES

1. Sign is Type II - Type F Reflective - reference WIS DOT Standard Specification for HIGHWAY and STRUCTURE CONSTRUCTION latest edition.
2. Color:
Background - Orange
Message - Black
3. Message Series - See note 5
4. Corners may be square or rounded when base material is plywood but borders shall be rounded as shown. When base material is metal, the corners and borders shall be rounded.
5. Line 1 is Series D.
Line 2 is Series D for AHEAD and Series C for all other distances.

7

7

SIZE	A	B	C	D	E	F	G	H	I	J	K	L	M	N	O	P	Q	R	S	T	U	V	W	X	Y	Z	Area sq. ft.
1	36		1 5/8	5/8	3/4	6	5	1	2 1/4	14 3/4	15	11 5/8	9	1 3/8	1 7/8	5 5/8	10 1/8	2 1/2	1 1/8	4 1/2	3 1/2	8	1 3/4	10 3/4			9.0
2S	48		2 1/4	3/4	1	8	7	1 1/4	3	19 3/4	20	15 1/2	12	1 7/8	2 5/8	7 1/2	13 1/2	3 3/8	1 1/2	6	4 5/8	10 5/8	2 3/8	14 3/8			16.0
2M	48		2 1/4	3/4	1	8	7	1 1/4	3	19 3/4	20	15 1/2	12	1 7/8	2 5/8	7 1/2	13 1/2	3 3/8	1 1/2	6	4 5/8	10 5/8	2 3/8	14 3/8			16.0
3	48		2 1/4	3/4	1	8	7	1 1/4	3	19 3/4	20	15 1/2	12	1 7/8	2 5/8	7 1/2	13 1/2	3 3/8	1 1/2	6	4 5/8	10 5/8	2 3/8	14 3/8			16.0
4	48		2 1/4	3/4	1	8	7	1 1/4	3	19 3/4	20	15 1/2	12	1 7/8	2 5/8	7 1/2	13 1/2	3 3/8	1 1/2	6	4 5/8	10 5/8	2 3/8	14 3/8			16.0
5	48		2 1/4	3/4	1	8	7	1 1/4	3	19 3/4	20	15 1/2	12	1 7/8	2 5/8	7 1/2	13 1/2	3 3/8	1 1/2	6	4 5/8	10 5/8	2 3/8	14 3/8			16.0

STANDARD SIGN
W20-2A, B, C, D, F & G

WISCONSIN DEPT OF TRANSPORTATION

APPROVED *Matthew R. Raub*
for State Traffic Engineer

DATE 3/18/11 PLATE NO. W20-2.6

PROJECT NO: _____ HWY: _____ COUNTY: _____ SHEET NO: _____ E

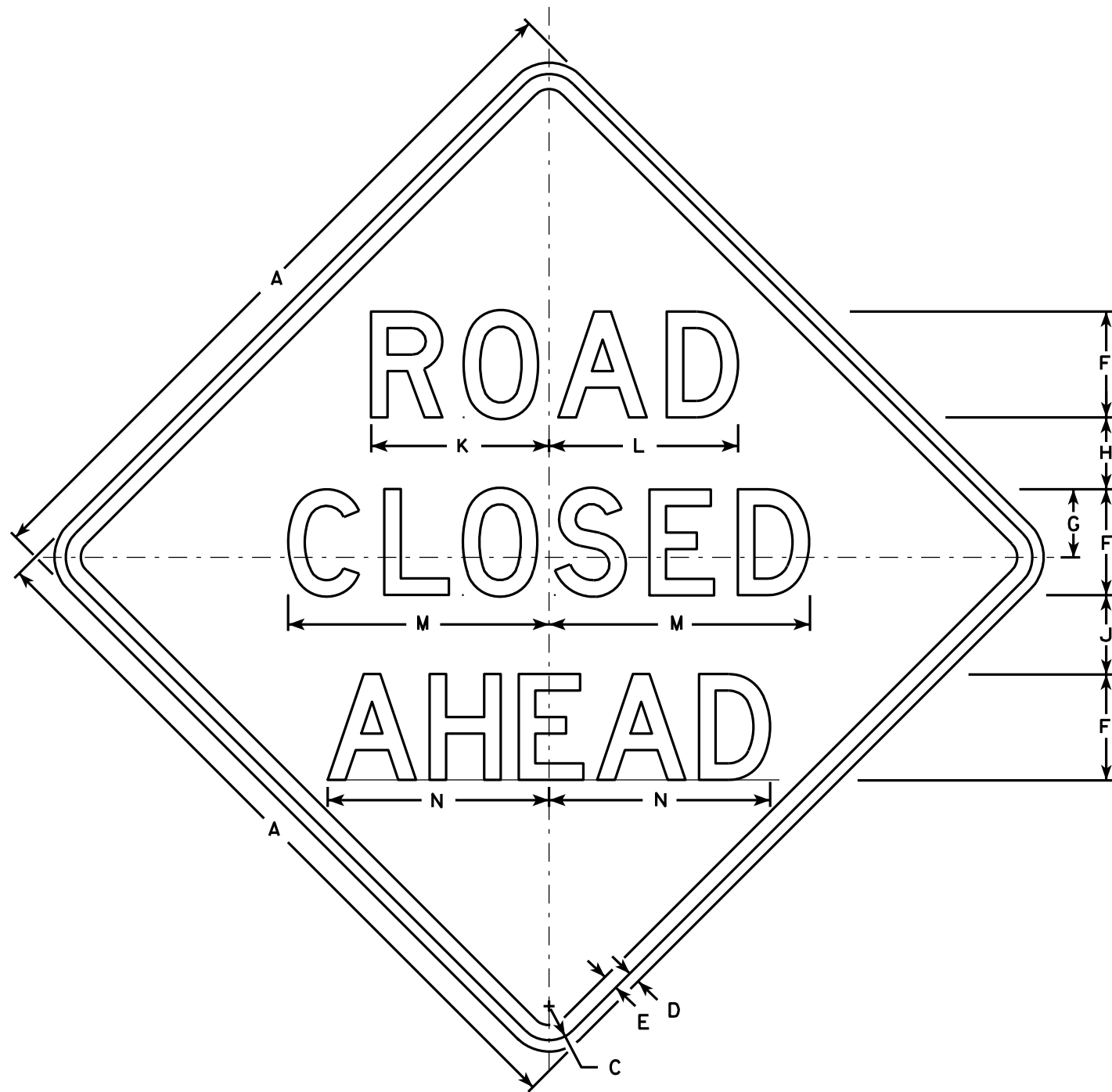

W20-3A

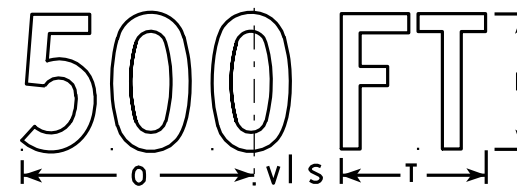

W20-3D

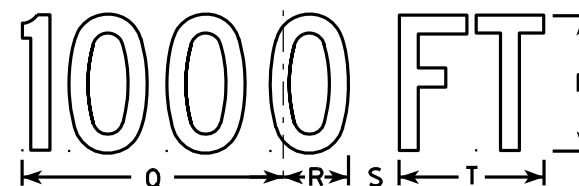

W20-3C

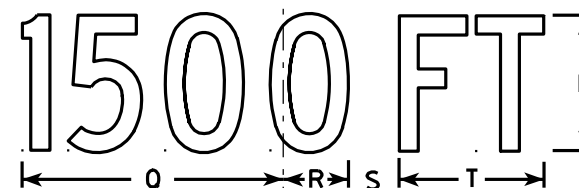

W20-3B

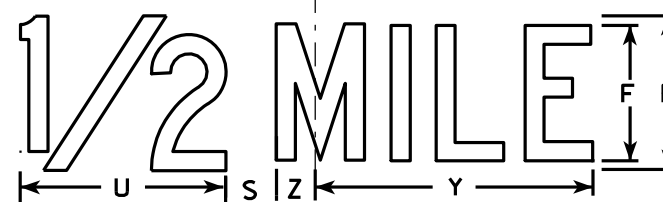

W20-3G

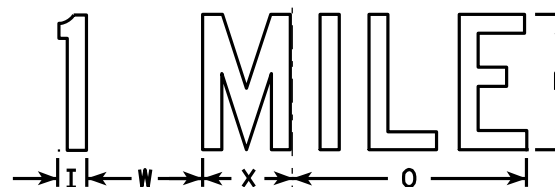

W20-3F

NOTES

1. Sign is Type II - Type F Reflective - reference WIS DOT Standard Specification for HIGHWAY and STRUCTURE CONSTRUCTION latest edition.
2. Color:
Background - Orange
Message - Black
3. Message Series - see note 5
4. Corners may be square or rounded when base material is plywood but borders shall be rounded as shown. When base material is metal, the corners and borders shall be rounded.
5. Lines 1 and 2 are Series D.
Line 3 is Series D for AHEAD and Series C for all other distances.

7

7

SIZE	A	B	C	D	E	F	G	H	I	J	K	L	M	N	O	P	Q	R	S	T	U	V	W	X	Y	Z	Area sq. ft.
1	36		1 5/8	5/8	3/4	5	3 3/8	3 1/2	1 1/8	4	8 3/8	8 7/8	12 1/2	11	9	6	10 1/8	2 1/2	1 7/8	5 5/8	8	1 3/8	4 1/2	3 1/2	10 3/4	1 3/4	9.0
2S	48		2 1/4	3/4	1	7	4 1/2	4 3/4	1 1/2	5 1/4	11 3/4	12 1/2	17 1/4	14 5/8	12	8	13 1/2	3 3/8	2 5/8	7 1/2	10 5/8	1 7/8	6	4 5/8	14 3/8	2 3/8	16.0
2M	48		2 1/4	3/4	1	7	4 1/2	4 3/4	1 1/2	5 1/4	11 3/4	12 1/2	17 1/4	14 5/8	12	8	13 1/2	3 3/8	2 5/8	7 1/2	10 5/8	1 7/8	6	4 5/8	14 3/8	2 3/8	16.0
3	48		2 1/4	3/4	1	7	4 1/2	4 3/4	1 1/2	5 1/4	11 3/4	12 1/2	17 1/4	14 5/8	12	8	13 1/2	3 3/8	2 5/8	7 1/2	10 5/8	1 7/8	6	4 5/8	14 3/8	2 3/8	16.0
4	48		2 1/4	3/4	1	7	4 1/2	4 3/4	1 1/2	5 1/4	11 3/4	12 1/2	17 1/4	14 5/8	12	8	13 1/2	3 3/8	2 5/8	7 1/2	10 5/8	1 7/8	6	4 5/8	14 3/8	2 3/8	16.0
5	48		2 1/4	3/4	1	7	4 1/2	4 3/4	1 1/2	5 1/4	11 3/4	12 1/2	17 1/4	14 5/8	12	8	13 1/2	3 3/8	2 5/8	7 1/2	10 5/8	1 7/8	6	4 5/8	14 3/8	2 3/8	16.0

STANDARD SIGN
W20-3A, B, C, D, F & G

WISCONSIN DEPT OF TRANSPORTATION

APPROVED *Matthew R. Rauch*
For State Traffic Engineer

DATE 3/18/11 PLATE NO. W20-3.7

PROJECT NO: _____ HWY: _____ COUNTY: _____ SHEET NO: _____ E

DIVISION 1 - CTH H

STATION	DISTANCE	AREA (SF)				INCREMENTAL VOL (CY) (UNADJUSTED)				CUMULATIVE VOL (CY)			
		CUT	SALVAGED/UNUSABLE PAVEMENT MATERIAL	FILL	ROCK EXC	CUT	SALVAGED/UNUSABLE PAVEMENT MATERIAL	FILL	ROCK EXC	CUT	EXPANDED FILL 1.25	EXPANDED ROCK 1.10	MASS ORDNATE
		NOTE 1	NOTE 2	NOTE 3		NOTE 1				NOTE 1			
10027.72	0.00	0.00	0.00	0.00	0.00	0	0	0	0	0	0	0	0
100+65	37.28	36.56	1.00	0.00	0.00	25	1	0	0	25	0	0	24
101+00	35.00	34.67	1.00	0.00	0.00	46	1	5	0	71	6	0	63
101+50	50.00	11.93	1.00	7.75	0.00	43	2	14	0	114	24	0	86
102+00	50.00	8.23	1.00	15.92	0.00	19	2	22	0	133	51	0	76
102+50	50.00	34.85	1.00	4.96	0.00	40	2	19	0	173	75	0	90
103+00	50.00	32.06	1.00	6.22	0.00	62	2	10	0	235	88	0	138
103+50	50.00	16.83	1.00	10.63	0.00	45	2	16	0	280	108	0	161
104+00	50.00	10.95	1.00	15.02	0.00	26	2	24	0	306	138	0	155
104+50	50.00	5.16	1.00	15.27	0.00	15	2	28	0	321	173	0	133
105+00	50.00	3.37	1.00	9.37	0.00	8	2	23	0	329	201	0	110
105+50	50.00	1.62	1.00	17.66	0.00	5	2	25	0	334	233	0	82
106+00	50.00	1.30	1.00	40.77	0.00	3	2	54	0	337	300	0	15
106+50	50.00	1.65	1.00	45.00	0.00	3	2	79	0	340	399	0	-83
107+00	50.00	1.33	1.00	32.11	0.00	3	2	71	0	343	488	0	-171
107+50	50.00	2.74	1.00	10.73	0.00	4	2	40	0	347	538	0	-219
108+00	50.00	16.56	1.00	4.35	0.00	18	2	14	0	365	555	0	-220
108+50	50.00	26.40	1.00	2.81	0.00	40	2	7	0	405	564	0	-191
109+00	50.00	60.20	1.00	2.78	0.00	80	2	5	0	485	570	0	-119
109+50	50.00	90.87	1.00	1.20	0.00	140	2	4	0	625	575	0	14
110+00	50.00	74.73	1.00	3.13	0.00	153	2	4	0	778	580	0	160
110+50	50.00	68.23	1.00	0.40	0.00	132	2	3	0	910	584	0	286
111+00	50.00	79.32	1.00	0.22	0.00	137	2	1	0	1,047	585	0	420
111+50	50.00	72.95	1.00	3.10	0.00	141	2	3	0	1,188	589	0	555
112+00	50.00	30.02	1.00	4.78	0.00	95	2	7	0	1,283	598	0	640
112+50	50.00	3.01	1.00	13.52	0.00	31	2	17	0	1,314	619	0	647
113+00	50.00	2.94	1.00	70.74	0.00	6	2	78	0	1,320	716	0	554
113+50	50.00	1.21	1.00	233.92	0.00	4	2	282	0	1,324	1,069	0	203
114+00	50.00	1.24	1.00	305.24	0.00	2	2	499	0	1,326	1,693	0	-421
114+50	50.00	1.88	1.00	311.85	0.00	3	2	571	0	1,329	2,406	0	-1,133
115+00	50.00	2.82	1.00	257.18	0.00	4	2	527	0	1,333	3,065	0	-1,790
115+50	50.00	2.39	1.00	154.31	0.00	5	2	381	0	1,338	3,541	0	-2,263
116+00	50.00	2.94	1.00	53.31	0.00	5	2	192	0	1,343	3,781	0	-2,500
116+50	50.00	8.25	1.00	8.23	0.00	10	2	57	0	1,353	3,853	0	-2,564
117+00	50.00	10.89	1.00	10.83	0.00	18	2	18	0	1,371	3,875	0	-2,570
117+50	50.00	3.81	1.00	11.24	0.00	14	2	20	0	1,385	3,900	0	-2,583
118+00	50.00	3.15	1.00	8.65	0.00	6	2	18	0	1,391	3,923	0	-2,602
118+50	50.00	4.07	1.00	12.45	0.00	7	2	20	0	1,398	3,948	0	-2,622
119+00	50.00	4.33	1.00	16.88	0.00	8	2	27	0	1,406	3,981	0	-2,649
119+50	50.00	5.53	1.00	40.80	0.00	9	2	53	0	1,415	4,048	0	-2,709
120+00	50.00	5.30	1.00	26.95	0.00	10	2	63	0	1,425	4,126	0	-2,779
120+50	50.00	6.38	1.00	23.59	0.00	11	2	47	0	1,436	4,185	0	-2,829
121+00	50.00	8.91	1.00	10.30	0.00	14	2	31	0	1,450	4,224	0	-2,856
121+50	50.00	13.46	1.00	3.21	0.00	21	2	13	0	1,471	4,240	0	-2,853
122+00	50.00	12.65	1.00	1.56	0.00	24	2	4	0	1,495	4,245	0	-2,836
122+50	50.00	10.02	1.00	143.16	0.00	21	2	134	0	1,516	4,413	0	-2,985
123+00	50.00	18.01	11.00	65.32	0.00	26	11	193	0	1,542	4,654	0	-3,211
123+50	50.00	24.59	11.00	7.52	0.00	39	20	67	0	1,581	4,738	0	-3,276
124+00	50.00	21.36	11.00	24.13	0.00	43	20	29	0	1,624	4,774	0	-3,289
124+50	50.00	12.15	11.00	83.18	0.00	31	20	99	0	1,655	4,898	0	-3,402
125+00	50.00	2.33	2.33	120.85	0.00	13	12	189	0	1,668	5,134	0	-3,637

Notes:	
1 - CUT	CUT INCLUDES SALVAGED/UNUSABLE PAVEMENT MATERIAL
2 - SALVAGED/UNUSABLE PAVEMENT MATERIAL	THIS DOES NOT SHOW UP IN CROSS SECTIONS
3 - FILL	DOES NOT INCLUDE UNUSABLE PAVEMENT EXC VOLUME

9

9

DIVISION 1 -- CTH H

STATION	DISTANCE	AREA (SF)				INCREMENTAL VOL (CY) (UNADJUSTED)				CUMULATIVE VOL (CY)			
		CUT	SALVAGED/UNUSABLE PAVEMENT MATERIAL	FILL	ROCK EXC	CUT NOTE 1	SALVAGED/UNUSABLE PAVEMENT MATERIAL NOTE 2	FILL NOTE 3	ROCK EXC	CUT NOTE 1	EXPANDED FILL 1.25	EXPANDED ROCK 1.10	MASS ORDNATE
125+50	50.00	0.00	0.00	114.21	0.00	2	2	218	0	1,670	5,406	0	-3,909
126+00	50.00	0.00	0.00	51.01	0.00	0	0	153	0	1,670	5,598	0	-4,101
126+50	50.00	3.25	3.25	62.65	0.00	3	3	105	0	1,673	5,729	0	-4,232
127+00	50.00	6.63	6.63	95.32	0.00	9	9	146	0	1,682	5,911	0	-4,414
127+50	50.00	36.46	11.00	32.94	0.00	40	16	119	0	1,722	6,060	0	-4,539
128+00	50.00	76.22	11.00	33.30	0.00	104	20	61	0	1,826	6,136	0	-4,531
128+50	50.00	117.14	11.00	19.00	0.00	179	20	48	0	2,005	6,196	0	-4,432
129+00	50.00	102.49	11.00	0.06	64.73	203	20	18	10	2,208	6,219	11	-4,261
129+50	50.00	104.95	11.00	0.00	123.51	192	20	0	101	2,400	6,219	122	-3,978
130+00	50.00	74.59	11.00	0.00	210.19	166	20	0	133	2,566	6,219	268	-3,685
130+50	50.00	46.56	11.00	0.00	348.23	112	20	0	208	2,678	6,219	497	-3,365
131+00	50.00	74.66	11.00	0.00	703.57	112	20	0	725	2,790	6,219	1,295	-2,475
131+50	50.00	29.36	11.00	0.00	539.03	96	20	0	989	2,886	6,219	2,383	-1,311
132+00	50.00	92.53	11.00	0.00	198.27	113	20	0	504	2,999	6,219	2,937	-664
132+50	50.00	26.97	11.00	0.00	208.58	111	20	0	214	3,110	6,219	3,172	-337
133+00	50.00	75.20	11.00	0.00	111.66	95	20	0	216	3,205	6,219	3,410	-25
133+50	50.00	166.80	11.00	0.07	0.00	224	20	0	76	3,429	6,219	3,494	263
134+00	50.00	117.13	11.00	0.00	0.00	263	20	0	0	3,692	6,219	3,494	506
134+50	50.00	82.75	11.00	0.00	0.00	185	20	0	0	3,877	6,219	3,494	671
135+00	50.00	55.55	11.00	0.00	0.00	128	20	0	0	4,005	6,219	3,494	779
135+50	50.00	26.33	11.00	4.33	0.00	76	20	4	0	4,081	6,224	3,494	830
136+00	50.00	7.73	7.73	22.83	0.00	32	17	25	0	4,113	6,255	3,494	814
136+35	35.00	11.04	1.00	18.13	0.00	12	6	27	0	4,125	6,289	3,494	786
136+50	15.00	1.48	1.00	18.04	0.00	3	1	10	0	4,128	6,301	3,494	775
137+00	50.00	0.84	0.84	23.30	0.00	2	2	38	0	4,130	6,349	3,494	728
137+50	50.00	2.71	1.00	23.00	0.00	3	2	43	0	4,133	6,403	3,494	675
138+00	50.00	8.57	1.00	16.10	0.00	10	2	36	0	4,143	6,448	3,494	638
138+50	50.00	2.64	1.00	14.25	0.00	10	2	28	0	4,153	6,483	3,494	611
139+00	50.00	20.77	1.00	10.79	0.00	22	2	23	0	4,175	6,511	3,494	602
139+50	50.00	24.14	1.00	8.73	0.00	42	2	18	0	4,217	6,534	3,494	620
140+00	50.00	19.41	1.00	5.30	0.00	40	2	13	0	4,257	6,550	3,494	642
140+50	50.00	14.59	1.00	13.49	0.00	31	2	17	0	4,288	6,571	3,494	649
141+00	50.00	15.16	1.00	11.45	0.00	28	2	23	0	4,316	6,600	3,494	647
141+50	50.00	7.05	1.00	10.87	0.00	21	2	21	0	4,337	6,626	3,494	639
142+00	50.00	4.49	1.00	8.45	0.00	11	2	18	0	4,348	6,649	3,494	626
142+50	50.00	2.16	1.00	10.42	0.00	6	2	17	0	4,354	6,670	3,494	609
143+00	50.00	0.57	0.57	23.97	0.00	3	1	32	0	4,357	6,710	3,494	571
143+50	50.00	0.67	0.67	28.61	0.00	1	1	49	0	4,358	6,771	3,494	509
144+00	50.00	1.05	1.00	29.67	0.00	2	2	54	0	4,360	6,839	3,494	442
144+50	50.00	1.27	1.00	28.37	0.00	2	2	54	0	4,362	6,906	3,494	374
145+00	50.00	1.64	1.00	26.27	0.00	3	2	51	0	4,365	6,970	3,494	312
145+50	50.00	2.60	1.00	27.55	0.00	4	2	50	0	4,369	7,033	3,494	251
146+00	50.00	4.15	1.00	24.72	0.00	6	2	48	0	4,375	7,093	3,494	195
146+50	50.00	9.68	1.00	7.90	0.00	13	2	30	0	4,388	7,130	3,494	169
147+00	50.00	3.08	1.00	20.28	0.00	12	2	26	0	4,400	7,163	3,494	146
147+50	50.00	3.07	1.00	35.53	0.00	6	2	52	0	4,406	7,228	3,494	85
148+00	50.00	6.79	1.00	17.23	0.00	9	2	49	0	4,415	7,289	3,494	31
148+50	50.00	8.36	1.00	18.19	0.00	14	2	33	0	4,429	7,330	3,494	2
149+00	50.00	2.58	1.00	22.65	0.00	10	2	38	0	4,439	7,378	3,494	-38
149+50	50.00	3.01	1.00	18.57	0.00	5	2	38	0	4,444	7,425	3,494	-82

Notes:	
1 - CUT	CUT INCLUDES SALVAGED/UNUSABLE PAVEMENT MATERIAL
2 - SALVAGED/UNUSABLE PAVEMENT MATERIAL	THIS DOES NOT SHOW UP IN CROSS SECTIONS
3 - FILL	DOES NOT INCLUDE UNUSABLE PAVEMENT EXC VOLUME

9

9

PROJECT NO: 7880-07-73

HWY: CTH H

COUNTY: DUNN

EARTHWORK QUANTITIES

SHEET

E

PLOT DATE: 10/18/2021

PLOT BY: CORRE, INC.

PLOT NAME:

PLOT SCALE 1:1

DIVISION 1 -- CTH H

STATION	DISTANCE	AREA (SF)				INCREMENTAL VOL (CY) (UNADJUSTED)				CUMULATIVE VOL (CY)			
		CUT	SALVAGED/UNUSABLE PAVEMENT MATERIAL	FILL	ROCK EXC	CUT	SALVAGED/UNUSABLE PAVEMENT MATERIAL	FILL	ROCK EXC	CUT	EXPANDED FILL	EXPANDED ROCK	MASS ORDNATE
150+00	50.00	2.59	1.00	18.76	0.00	5	2	35	0	4,449	7,469	3,494	-123
150+50	50.00	1.84	1.00	41.43	0.00	4	2	56	0	4,453	7,539	3,494	-191
151+00	50.00	1.12	1.00	55.17	0.00	3	2	89	0	4,456	7,650	3,494	-301
151+50	50.00	1.53	1.00	63.14	0.00	2	2	110	0	4,458	7,788	3,494	-439
152+00	50.00	1.97	1.00	10.84	0.00	3	2	68	0	4,461	7,873	3,494	-523
152+50	50.00	1.41	1.00	50.43	0.00	3	2	57	0	4,464	7,944	3,494	-593
153+00	50.00	1.90	1.00	17.87	0.00	3	2	63	0	4,467	8,023	3,494	-671
153+50	50.00	2.03	1.00	16.53	0.00	4	2	32	0	4,471	8,063	3,494	-709
154+00	50.00	2.13	1.00	15.05	0.00	4	2	29	0	4,475	8,099	3,494	-743
154+50	50.00	2.26	1.00	16.65	0.00	4	2	29	0	4,479	8,135	3,494	-777
155+00	50.00	1.49	1.00	16.75	0.00	3	2	31	0	4,482	8,174	3,494	-815
155+50	50.00	86.70	1.00	13.70	0.00	82	2	28	0	4,564	8,209	3,494	-770
156+00	50.00	105.48	1.00	14.87	0.00	178	2	26	0	4,742	8,241	3,494	-627
156+50	50.00	65.17	1.00	17.80	0.00	158	2	30	0	4,900	8,279	3,494	-508
157+00	50.00	1.74	1.00	17.53	0.00	62	2	33	0	4,962	8,320	3,494	-489
157+50	50.00	2.07	1.00	30.77	0.00	4	2	45	0	4,966	8,376	3,494	-544
158+00	50.00	0.96	0.96	46.29	0.00	3	2	71	0	4,969	8,465	3,494	-631
158+50	50.00	0.84	0.84	14.74	0.00	2	2	57	0	4,971	8,536	3,494	-703
159+00	50.00	177.74	1.00	4.35	0.00	165	2	18	0	5,136	8,559	3,494	-562
159+50	50.00	381.10	1.00	2.05	0.00	517	2	6	0	5,653	8,566	3,494	-55
160+00	50.00	128.20	1.00	0.08	0.00	472	2	2	0	6,125	8,569	3,494	413
160+50	50.00	10.50	1.00	44.10	0.00	128	2	41	0	6,253	8,620	3,494	488
161+00	50.00	17.54	1.00	67.06	0.00	26	2	103	0	6,279	8,749	3,494	383
161+50	50.00	53.78	1.00	7.50	0.00	66	2	69	0	6,345	8,835	3,494	361
162+00	50.00	89.39	1.00	5.53	0.00	133	2	12	0	6,478	8,850	3,494	477
162+50	50.00	72.65	1.00	6.85	0.00	150	2	11	0	6,628	8,864	3,494	611
163+00	50.00	54.19	1.00	8.77	0.00	117	2	14	0	6,745	8,881	3,494	708
163+50	50.00	79.55	1.00	18.63	0.00	124	2	25	0	6,869	8,913	3,494	799
164+00	50.00	129.40	1.00	46.71	0.00	193	2	60	0	7,062	8,988	3,494	915
164+50	50.00	163.33	1.00	26.24	0.00	271	2	68	0	7,333	9,073	3,494	1,099
165+00	50.00	147.57	1.00	21.00	0.00	288	2	44	0	7,621	9,128	3,494	1,330
165+50	50.00	89.66	1.00	22.17	0.00	220	2	40	0	7,841	9,178	3,494	1,498
166+00	50.00	38.48	1.00	23.71	0.00	119	2	42	0	7,960	9,230	3,494	1,563
166+50	50.00	24.34	1.00	25.60	0.00	58	2	46	0	8,018	9,288	3,494	1,561
167+00	50.00	5.63	1.00	37.39	0.00	28	2	58	0	8,046	9,360	3,494	1,515
167+50	50.00	1.29	1.00	30.30	0.00	6	2	63	0	8,052	9,439	3,494	1,440
168+00	50.00	3.33	1.00	33.44	0.00	4	2	59	0	8,056	9,513	3,494	1,368
168+50	50.00	1.87	1.00	37.80	0.00	5	2	66	0	8,061	9,595	3,494	1,289
169+00	50.00	1.61	1.00	35.90	0.00	3	2	68	0	8,064	9,680	3,494	1,205
169+50	50.00	1.24	1.00	34.38	0.00	3	2	65	0	8,067	9,761	3,494	1,124
170+00	50.00	1.27	1.00	32.36	0.00	2	2	62	0	8,069	9,839	3,494	1,047
170+50	50.00	1.47	1.00	30.01	0.00	3	2	58	0	8,072	9,911	3,494	975
171+00	50.00	1.60	1.00	27.46	0.00	3	2	53	0	8,075	9,978	3,494	910
171+50	50.00	3.11	1.00	10.80	0.00	4	2	35	0	8,079	10,021	3,494	868
172+00	50.00	2.37	1.00	13.89	0.00	5	2	23	0	8,084	10,050	3,494	843
172+50	50.00	3.69	1.00	3.44	0.00	6	2	16	0	8,090	10,070	3,494	827
173+00	50.00	54.48	1.00	0.46	0.00	54	2	4	0	8,144	10,075	3,494	874
173+50	50.00	78.39	1.00	3.27	0.00	123	2	3	0	8,267	10,079	3,494	991
174+00	50.00	135.00	1.00	5.58	0.00	198	2	8	0	8,465	10,089	3,494	1,177
174+50	50.00	177.66	1.00	7.85	0.00	289	2	12	0	8,754	10,104	3,494	1,449

Notes:	
1 - CUT	CUT INCLUDES SALVAGED/UNUSABLE PAVEMENT MATERIAL
2 - SALVAGED/UNUSABLE PAVEMENT MATERIAL	THIS DOES NOT SHOW UP IN CROSS SECTIONS
3 - FILL	DOES NOT INCLUDE UNUSABLE PAVEMENT EXC VOLUME

9

9

PROJECT NO: 7880-07-73

HWY: CTH H

COUNTY: DUNN

EARTHWORK QUANTITIES

SHEET

E

PLOT DATE: 10/18/2021

PLOT BY: CORRE, INC.

PLOT NAME:

PLOT SCALE 1:1

DIVISION 1 -- CTH H

STATION	DISTANCE	AREA (SF)				INCREMENTAL VOL (CY) (UNADJUSTED)				CUMULATIVE VOL (CY)			
		CUT	SALVAGED/UNUSABLE PAVEMENT MATERIAL	FILL	ROCK EXC	CUT	SALVAGED/UNUSABLE PAVEMENT MATERIAL	FILL	ROCK EXC	CUT	EXPANDED FILL	EXPANDED ROCK	MASS ORDNATE
175+00	50.00	124.10	1.00	6.19	0.00	279	2	13	0	9,033	10,120	3,494	1,710
175+50	50.00	88.55	1.00	0.00	0.00	197	2	6	0	9,230	10,128	3,494	1,897
176+00	50.00	67.42	1.00	0.00	0.00	144	2	0	0	9,374	10,128	3,494	2,039
176+50	50.00	48.90	1.00	0.20	0.00	108	2	0	0	9,482	10,128	3,494	2,145
177+00	50.00	25.78	1.00	0.47	0.00	69	2	1	0	9,551	10,129	3,494	2,211
177+50	50.00	11.78	1.00	16.86	0.00	35	2	16	0	9,586	10,149	3,494	2,224
178+00	50.00	1.85	1.00	17.74	0.00	13	2	32	0	9,599	10,189	3,494	2,195
178+50	50.00	2.13	1.00	6.12	0.00	4	2	22	0	9,603	10,216	3,494	2,169
179+00	50.00	31.49	1.00	0.00	0.00	31	2	6	0	9,634	10,224	3,494	2,191
179+50	50.00	37.36	1.00	0.00	0.00	64	2	0	0	9,698	10,224	3,494	2,253
180+00	50.00	6.82	1.00	5.04	0.00	41	2	5	0	9,739	10,230	3,494	2,286
180+50	50.00	2.98	1.00	12.82	0.00	9	2	17	0	9,748	10,251	3,494	2,271
181+00	50.00	3.67	1.00	20.59	0.00	6	2	31	0	9,754	10,290	3,494	2,237
181+50	50.00	3.30	1.00	14.29	0.00	6	2	32	0	9,760	10,330	3,494	2,201
182+00	50.00	3.45	1.00	13.07	0.00	6	2	25	0	9,766	10,361	3,494	2,173
182+50	50.00	16.50	1.00	7.95	0.00	18	2	19	0	9,784	10,385	3,494	2,166
183+00	50.00	42.67	1.00	8.80	0.00	55	2	16	0	9,839	10,405	3,494	2,199
183+50	50.00	8.63	1.00	14.59	0.00	48	2	22	0	9,887	10,433	3,494	2,217
184+00	50.00	8.65	1.00	20.74	0.00	16	2	33	0	9,903	10,474	3,494	2,190
184+50	50.00	7.87	1.00	19.94	0.00	15	2	38	0	9,918	10,521	3,494	2,155
185+00	50.00	18.09	1.00	5.61	0.00	24	2	24	0	9,942	10,551	3,494	2,147
185+50	50.00	14.96	1.00	0.39	0.00	31	2	6	0	9,973	10,559	3,494	2,169
186+00	50.00	20.41	1.00	0.10	0.00	33	2	0	0	10,006	10,559	3,494	2,200
186+50	50.00	32.79	1.00	4.25	0.00	49	2	4	0	10,055	10,564	3,494	2,242
187+00	50.00	8.39	1.00	17.58	0.00	38	2	20	0	10,093	10,589	3,494	2,253
187+50	50.00	6.61	1.00	25.51	0.00	14	2	40	0	10,107	10,639	3,494	2,215
188+00	50.00	6.54	1.00	34.48	0.00	12	2	56	0	10,119	10,709	3,494	2,155
188+50	50.00	7.44	1.00	30.37	0.00	13	2	60	0	10,132	10,784	3,494	2,091
189+00	50.00	7.44	1.00	25.31	0.00	14	2	52	0	10,146	10,849	3,494	2,038
189+50	50.00	5.05	1.00	19.56	0.00	12	2	42	0	10,158	10,901	3,494	1,995
190+00	50.00	2.58	1.00	4.86	0.00	7	2	23	0	10,165	10,930	3,494	1,972
190+50	50.00	18.00	1.00	0.06	0.00	19	2	5	0	10,184	10,936	3,494	1,982
191+00	50.00	22.42	1.00	5.99	0.00	37	2	6	0	10,221	10,944	3,494	2,010
191+50	50.00	9.12	1.00	8.81	0.00	29	2	14	0	10,250	10,961	3,494	2,019
192+00	50.00	9.50	1.00	12.07	0.00	17	2	19	0	10,267	10,985	3,494	2,011
192+50	50.00	7.09	1.00	16.09	0.00	15	2	26	0	10,282	11,018	3,494	1,991
193+00	50.00	10.16	1.00	19.12	0.00	16	2	33	0	10,298	11,059	3,494	1,964
193+50	50.00	5.03	1.00	19.20	0.00	14	2	35	0	10,312	11,103	3,494	1,932
194+00	50.00	1.84	1.00	27.54	0.00	6	2	43	0	10,318	11,156	3,494	1,882
194+50	50.00	3.95	1.00	10.57	0.00	5	2	35	0	10,323	11,200	3,494	1,842
195+00	50.00	5.94	1.00	3.63	0.00	9	2	13	0	10,332	11,216	3,494	1,832
195+50	50.00	18.57	1.00	3.82	0.00	23	2	7	0	10,355	11,225	3,494	1,845
196+00	50.00	5.10	1.00	6.38	0.00	22	2	9	0	10,377	11,236	3,494	1,853
196+50	50.00	18.75	11.00	11.69	0.00	22	11	17	0	10,399	11,258	3,494	1,843
197+00	50.00	34.30	11.00	3.11	0.00	49	20	14	0	10,448	11,275	3,494	1,855
197+50	50.00	51.17	11.00	2.88	0.00	79	20	6	0	10,527	11,283	3,494	1,906
198+00	50.00	95.86	11.00	0.00	0.00	136	20	3	0	10,663	11,286	3,494	2,018
198+50	50.00	124.22	11.00	0.00	0.00	204	20	0	0	10,867	11,286	3,494	2,202
199+00	50.00	128.78	11.00	0.00	0.00	234	20	0	0	11,101	11,286	3,494	2,416
199+50	50.00	117.51	11.00	0.00	0.00	228	20	0	0	11,329	11,286	3,494	2,624

Notes:	
1 - CUT	CUT INCLUDES SALVAGED/UNUSABLE PAVEMENT MATERIAL
2 - SALVAGED/UNUSABLE PAVEMENT MATERIAL	THIS DOES NOT SHOW UP IN CROSS SECTIONS
3 - FILL	DOES NOT INCLUDE UNUSABLE PAVEMENT EXC VOLUME

9

9

PROJECT NO: 7880-07-73

HWY: CTH H

COUNTY: DUNN

EARTHWORK QUANTITIES

SHEET

E

PLOT DATE: 10/18/2021

PLOT BY: CORRE, INC.

PLOT NAME:

PLOT SCALE 1:1

DIVISION 1 -- CTH H

STATION	DISTANCE	AREA (SF)				INCREMENTAL VOL (CY) (UNADJUSTED)				CUMULATIVE VOL (CY)			
		CUT	SALVAGED/UNUSABLE PAVEMENT MATERIAL	FILL	ROCK EXC	CUT	SALVAGED/UNUSABLE PAVEMENT MATERIAL	FILL	ROCK EXC	CUT	EXPANDED FILL	EXPANDED ROCK	MASS ORDNATE
200+00	50.00	87.69	11.00	0.03	0.00	190	20	0	0	11,519	11,286	3,494	2,794
200+50	50.00	55.95	11.00	1.15	0.00	133	20	1	0	11,652	11,288	3,494	2,906
201+00	50.00	37.43	11.00	2.11	0.00	86	20	3	0	11,738	11,291	3,494	2,968
201+50	50.00	33.43	11.00	3.68	0.00	66	20	5	0	11,804	11,298	3,494	3,008
202+00	50.00	33.97	11.00	5.91	0.00	62	20	9	0	11,866	11,309	3,494	3,039
202+50	50.00	24.73	11.00	12.35	0.00	54	20	17	0	11,920	11,330	3,494	3,052
203+00	50.00	5.44	1.00	7.83	0.00	28	11	19	0	11,948	11,354	3,494	3,045
203+50	50.00	18.24	1.00	4.82	0.00	22	2	12	0	11,970	11,369	3,494	3,050
204+00	50.00	5.76	1.00	5.12	0.00	22	2	9	0	11,992	11,380	3,494	3,059
204+50	50.00	6.06	1.00	6.21	0.00	11	2	10	0	12,003	11,393	3,494	3,055
205+00	50.00	7.14	1.00	7.50	0.00	12	2	13	0	12,015	11,409	3,494	3,049
205+50	50.00	4.86	1.00	21.12	0.00	11	2	27	0	12,026	11,443	3,494	3,024
207+00	0.00	19.40	1.00	0.05	0.00	0	0	0	0	12,026	11,443	3,494	3,024
207+50	50.00	4.94	1.00	11.70	0.00	23	2	11	0	12,049	11,456	3,494	3,031
208+00	50.00	8.25	1.00	7.84	0.00	12	2	18	0	12,061	11,479	3,494	3,019
208+50	50.00	9.01	1.00	8.22	0.00	16	2	15	0	12,077	11,498	3,494	3,014
209+00	50.00	13.83	1.00	5.72	0.00	21	2	13	0	12,098	11,514	3,494	3,017
209+50	50.00	4.38	1.00	11.13	0.00	17	2	16	0	12,115	11,534	3,494	3,012
210+00	50.00	5.62	1.00	24.78	0.00	9	2	33	0	12,124	11,575	3,494	2,978
210+50	50.00	3.88	1.00	30.21	0.00	9	2	51	0	12,133	11,639	3,494	2,921
211+00	50.00	4.70	1.00	37.67	0.00	8	2	63	0	12,141	11,718	3,494	2,848
211+50	50.00	4.27	1.00	32.59	0.00	8	2	65	0	12,149	11,799	3,494	2,773
212+00	50.00	5.26	1.00	27.84	0.00	9	2	56	0	12,158	11,869	3,494	2,710
212+50	50.00	5.01	1.00	13.45	0.00	10	2	38	0	12,168	11,916	3,494	2,670
213+00	50.00	7.12	1.00	5.90	0.00	11	2	18	0	12,179	11,939	3,494	2,657
213+50	50.00	14.39	1.00	3.22	0.00	20	2	8	0	12,199	11,949	3,494	2,665
214+00	50.00	9.55	1.00	6.39	0.00	22	2	9	0	12,221	11,960	3,494	2,674
214+50	50.00	8.03	1.00	5.37	0.00	16	2	11	0	12,237	11,974	3,494	2,674
215+00	50.00	17.45	1.00	2.50	0.00	24	2	7	0	12,261	11,983	3,494	2,687
215+50	50.00	8.03	1.00	2.59	0.00	24	2	5	0	12,285	11,989	3,494	2,703
216+00	50.00	2.12	1.00	2.55	0.00	9	2	5	0	12,294	11,995	3,494	2,704
216+50	50.00	2.05	1.00	5.30	0.00	4	2	7	0	12,298	12,004	3,494	2,697
217+00	50.00	7.97	1.00	10.65	0.00	9	2	15	0	12,307	12,023	3,494	2,685
217+50	50.00	6.76	1.00	8.63	0.00	14	2	18	0	12,321	12,045	3,494	2,675
218+00	50.00	1.51	1.00	5.30	0.00	8	2	13	0	12,329	12,061	3,494	2,664
218+50	50.00	0.93	0.93	4.83	0.00	2	2	9	0	12,331	12,073	3,494	2,653
219+00	50.00	1.77	1.00	28.36	0.00	3	2	31	0	12,334	12,111	3,494	2,615
219+50	50.00	1.23	1.00	39.56	0.00	3	2	63	0	12,337	12,190	3,494	2,538
220+00	50.00	1.01	1.00	26.36	0.00	2	2	61	0	12,339	12,266	3,494	2,461
220+50	50.00	1.15	1.00	16.53	0.00	2	2	40	0	12,341	12,316	3,494	2,411
221+00	50.00	1.93	1.00	4.90	0.00	3	2	20	0	12,344	12,341	3,494	2,387
221+50	50.00	2.87	1.00	4.81	0.00	4	2	9	0	12,348	12,353	3,494	2,378
222+00	50.00	2.85	1.00	9.30	0.00	5	2	13	0	12,353	12,369	3,494	2,365
222+50	50.00	2.12	1.00	13.87	0.00	5	2	21	0	12,358	12,395	3,494	2,342
223+00	50.00	1.49	1.00	11.74	0.00	3	2	24	0	12,361	12,425	3,494	2,313
223+50	50.00	1.78	1.00	8.16	0.00	3	2	18	0	12,364	12,448	3,494	2,291
224+00	50.00	3.17	1.00	4.20	0.00	5	2	11	0	12,369	12,461	3,494	2,280
224+50	50.00	1.51	1.00	8.58	0.00	4	2	12	0	12,373	12,476	3,494	2,267
225+00	50.00	1.90	1.00	8.06	0.00	3	2	15	0	12,376	12,495	3,494	2,250
225+50	50.00	2.20	1.00	7.29	0.00	4	2	14	0	12,380	12,513	3,494	2,234
226+00	50.00	6.98	1.00	7.68	0.00	9	2	14	0	12,389	12,530	3,494	2,224

Notes:	
1 - CUT	CUT INCLUDES SALVAGED/UNUSABLE PAVEMENT MATERIAL
2 - SALVAGED/UNUSABLE PAVEMENT MATERIAL	THIS DOES NOT SHOW UP IN CROSS SECTIONS
3 - FILL	DOES NOT INCLUDE UNUSABLE PAVEMENT EXC VOLUME

9

9

PROJECT NO: 7880-07-73

HWY: CTH H

COUNTY: DUNN

EARTHWORK QUANTITIES

SHEET

E

PLOT DATE: 10/18/2021

PLOT BY: CORRE, INC.

PLOT NAME:

PLOT SCALE 1:1

DIVISION 1 -- CTH H

STATION	DISTANCE	AREA (SF)				INCREMENTAL VOL (CY) (UNADJUSTED)				CUMULATIVE VOL (CY)			
		CUT	SALVAGED/UNUSABLE PAVEMENT MATERIAL	FILL	ROCK EXC	CUT	SALVAGED/UNUSABLE PAVEMENT MATERIAL	FILL	ROCK EXC	CUT	EXPANDED FILL	EXPANDED ROCK	MASS ORDINATE
						NOTE 1	NOTE 2	NOTE 3		NOTE 1	1.25	1.10	
226+50	50.00	7.57	1.00	8.11	0.00	13	2	15	0	12,402	12,549	3,494	2,216
227+00	50.00	8.94	1.00	5.22	0.00	15	2	12	0	12,417	12,564	3,494	2,214
227+50	50.00	8.49	1.00	2.75	0.00	16	2	7	0	12,433	12,573	3,494	2,219
228+00	50.00	5.27	1.00	4.89	0.00	13	2	7	0	12,446	12,581	3,494	2,221
228+50	50.00	5.87	1.00	5.27	0.00	10	2	9	0	12,456	12,593	3,494	2,218
229+00	50.00	11.67	1.00	13.39	0.00	16	2	17	0	12,472	12,614	3,494	2,211
229+50	50.00	3.35	1.00	5.44	0.00	14	2	17	0	12,486	12,635	3,494	2,202
230+00	50.00	4.37	1.00	3.41	0.00	7	2	8	0	12,493	12,645	3,494	2,197
230+50	50.00	4.49	1.00	6.16	0.00	8	2	9	0	12,501	12,656	3,494	2,191
231+00	50.00	3.79	1.00	20.06	0.00	8	2	24	0	12,509	12,686	3,494	2,167
231+50	50.00	24.40	1.00	8.34	0.00	26	2	26	0	12,535	12,719	3,494	2,159
232+00	50.00	4.79	1.00	10.58	0.00	27	2	18	0	12,562	12,741	3,494	2,161
232+50	50.00	6.39	1.00	7.68	0.00	10	2	17	0	12,572	12,763	3,494	2,148
233+00	50.00	3.28	1.00	9.04	0.00	9	2	15	0	12,581	12,781	3,494	2,136
233+50	50.00	14.17	1.00	8.03	0.00	16	2	16	0	12,597	12,801	3,494	2,130
234+00	50.00	111.27	1.00	16.84	0.00	116	2	23	0	12,713	12,830	3,494	2,216
234+25.77	25.77	105.54	1.00	13.52	0.00	103	1	14	0	12,816	12,848	3,494	2,300

Notes:	
1 - CUT	CUT INCLUDES SALVAGED/UNUSABLE PAVEMENT MATERIAL
2 - SALVAGED/UNUSABLE PAVEMENT MATERIAL	THIS DOES NOT SHOW UP IN CROSS SECTIONS
3 - FILL	DOES NOT INCLUDE UNUSABLE PAVEMENT EXC VOLUME

9

9

DIVISION 2 -- 630TH AVE

STATION	DISTANCE	AREA (SF)			INCREMENTAL VOL (CY) (UNADJUSTED)			CUMULATIVE VOL (CY)		
		CUT	SALVAGED/UNUSABLE PAVEMENT MATERIAL	FILL	CUT	SALVAGED/UNUSABLE PAVEMENT MATERIAL	FILL	CUT	EXPANDED FILL 1.25	MASS ORDINATE
498+54.00	0.00	25.13	5.00	7.16	0	0	0	0	0	0
499+00.00	46.00	22.02	5.00	28.00	121	26	90	121	112	-17
499+50.00	50.00	10.18	5.00	47.78	89	28	211	210	375	-219
499+60.00	10.00	9.08	5.00	158.68	11	6	115	221	519	-357
CTH H										
500+50.00	0.00	6.00	5.00	120.73	0	0	0	221	519	-357
501+00.00	50.00	21.46	5.00	25.54	76	28	406	297	1,027	-816
501+50.00	50.00	23.43	5.00	3.18	125	28	80	422	1,126	-819
501+75.00	25.00	22.77	5.00	9.71	64	14	18	486	1,149	-791

DIVISION 2 -- 690TH AVE

STATION	DISTANCE	AREA (SF)			INCREMENTAL VOL (CY) (UNADJUSTED)			CUMULATIVE VOL (CY)		
		CUT	SALVAGED/UNUSABLE PAVEMENT MATERIAL	FILL	CUT	SALVAGED/UNUSABLE PAVEMENT MATERIAL	FILL	CUT	EXPANDED FILL 1.25	MASS ORDINATE
798+74.00	0.00	28.58	5.00	2.91	0	0	0	0	0	0
799+00.00	26.00	21.91	5.00	15.65	73	14	27	73	34	25
799+60.00	60.00	21.23	5.00	115.14	144	33	436	217	578	-409
CTH H										
800+40.00	0.00	100.62	5.00	17.89	0	0	0	217	578	-409
800+75.00	35.00	63.75	5.00	7.06	320	19	49	536	639	-170
801+03.00	28.00	33.83	5.00	0.66	152	16	12	688	654	-49

Notes:	
1 - CUT	CUT INCLUDES SALVAGED/UNUSABLE PAVEMENT MATERIAL
2 - SALVAGED/UNUSABLE PAVEMENT MATERIAL	THIS DOES NOT SHOW UP IN CROSS SECTIONS
3 - FILL	DOES NOT INCLUDE UNUSABLE PAVEMENT EXC VOLUME

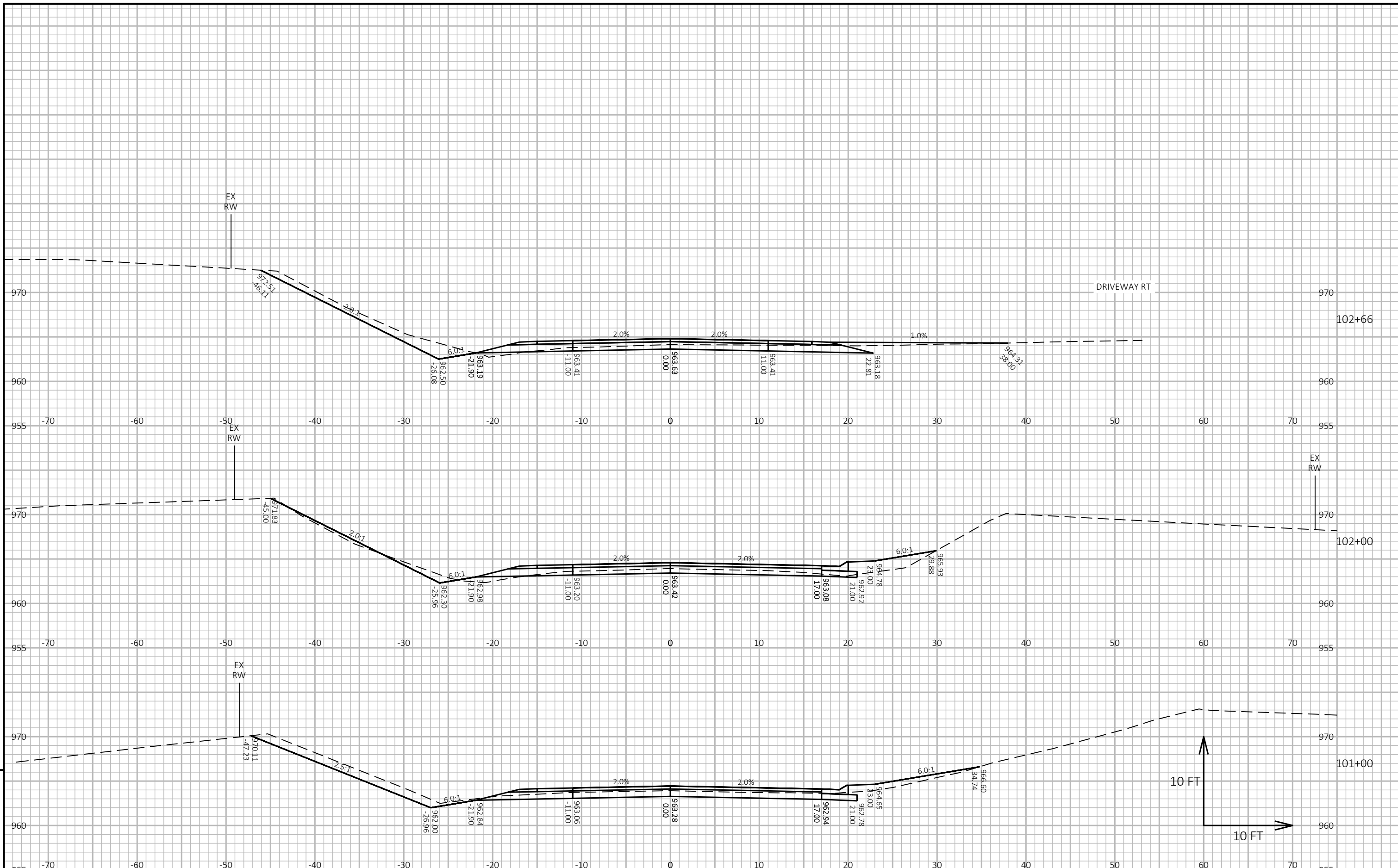

PROJECT NO: 7880-07-73

HWY: CTH H

COUNTY: DUNN

CROSS SECTIONS: CTH H

SHEET

E

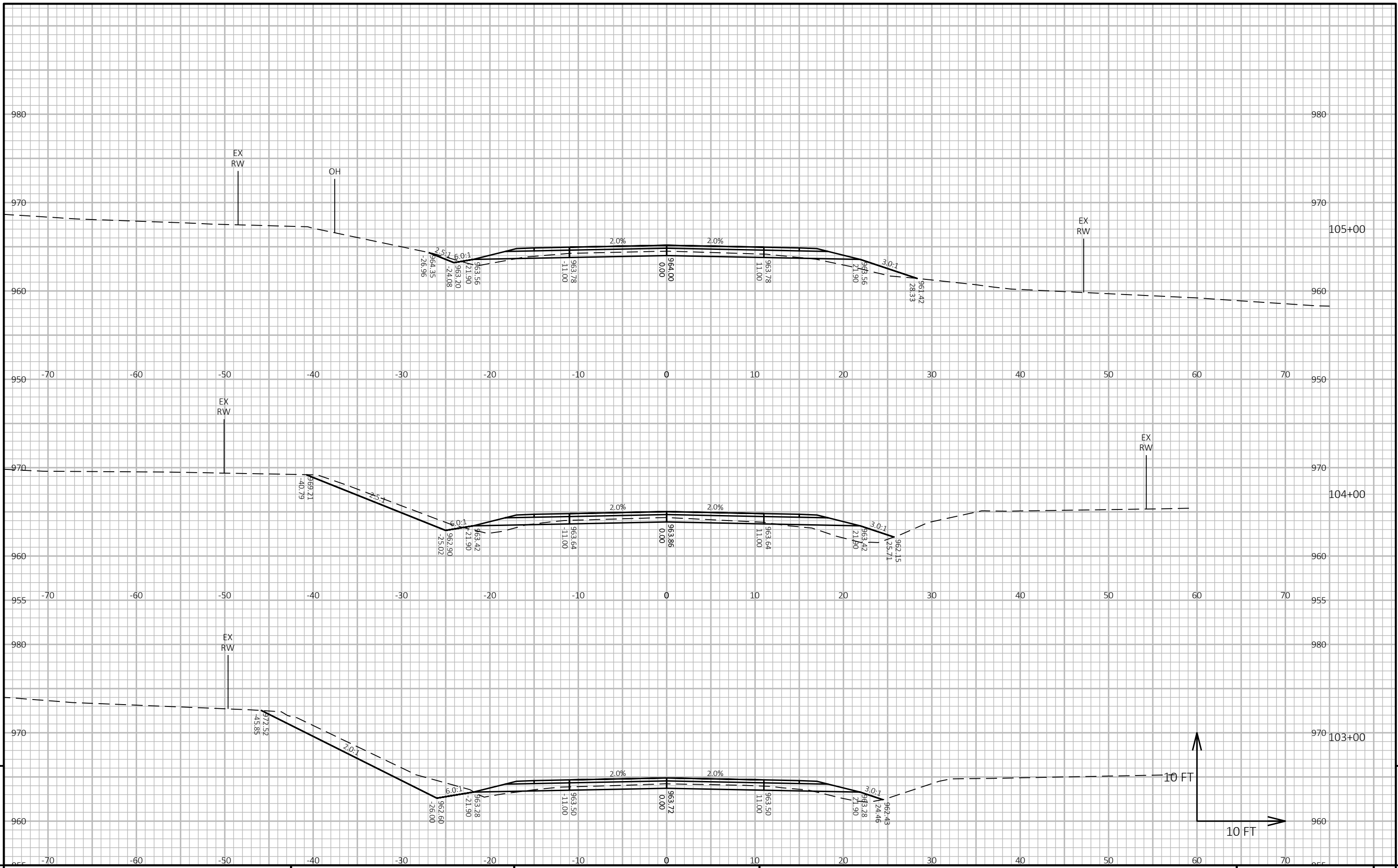

PROJECT NO: 7880-07-73

HWY: CTH H

COUNTY: DUNN

CROSS SECTIONS: CTH H

SHEET

E

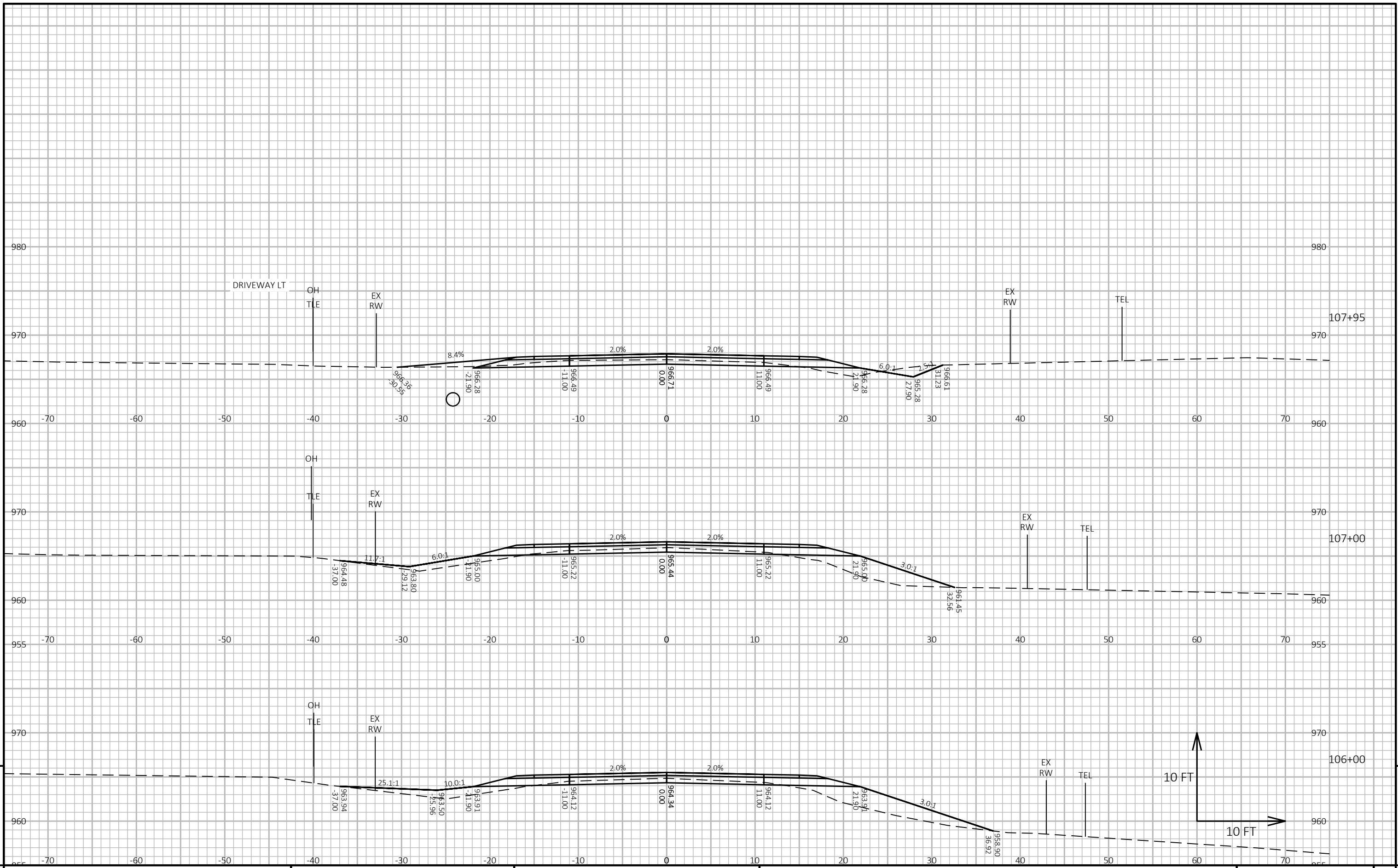

PROJECT NO: 7880-07-73	HWY: CTH H	COUNTY: DUNN	CROSS SECTIONS: CTH H	SHEET	E
------------------------	------------	--------------	-----------------------	-------	----------

9

9

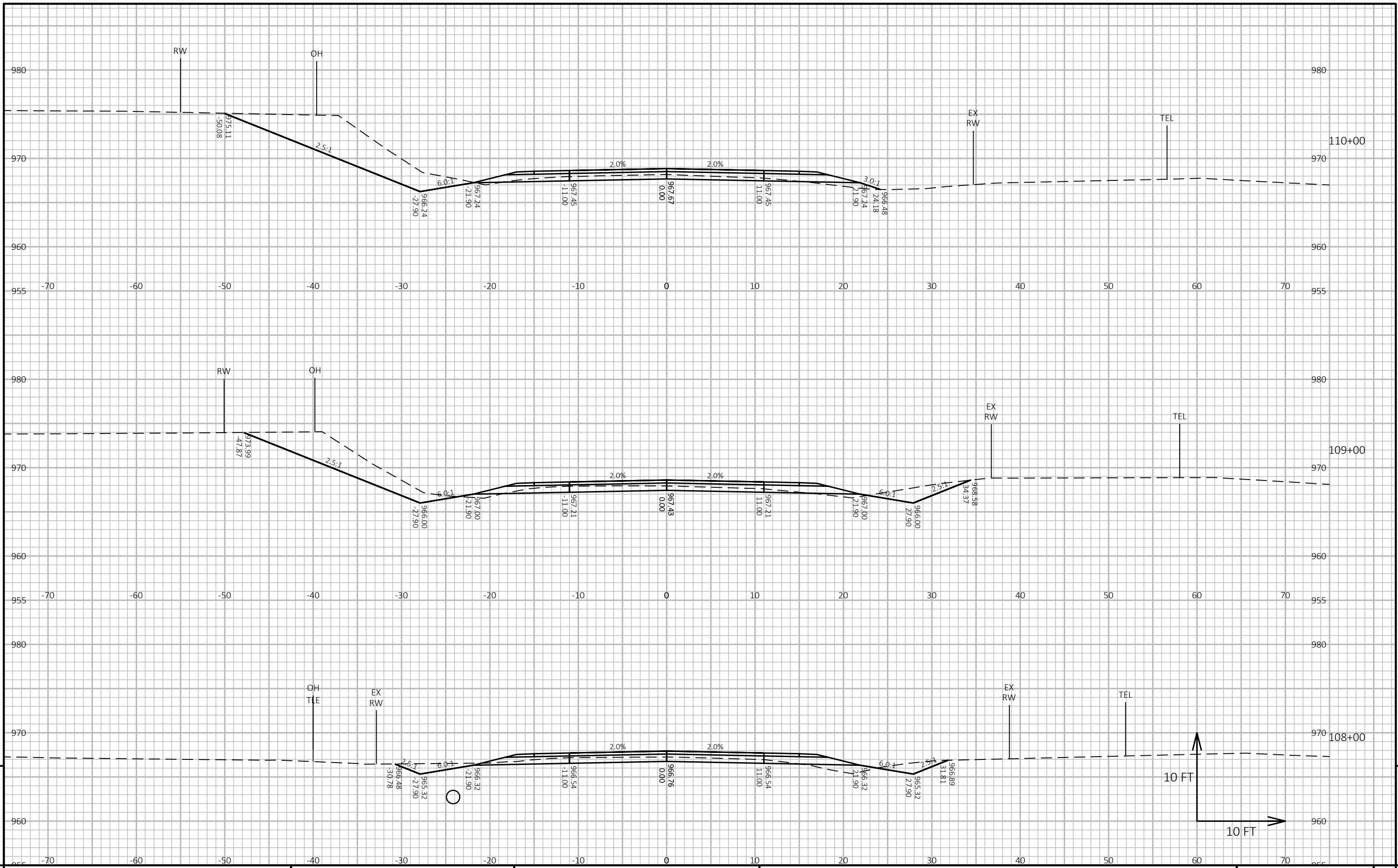

PROJECT NO: 7880-07-73 HWY: CTH H COUNTY: DUNN CROSS SECTIONS: CTH H SHEET E

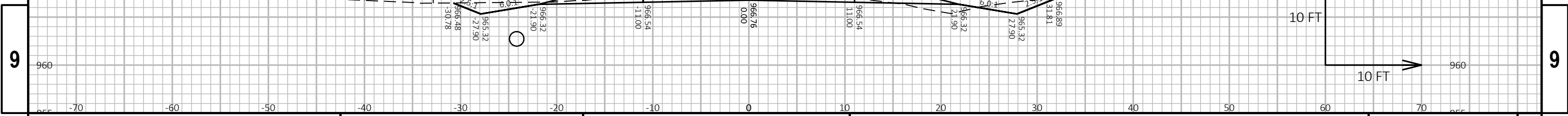

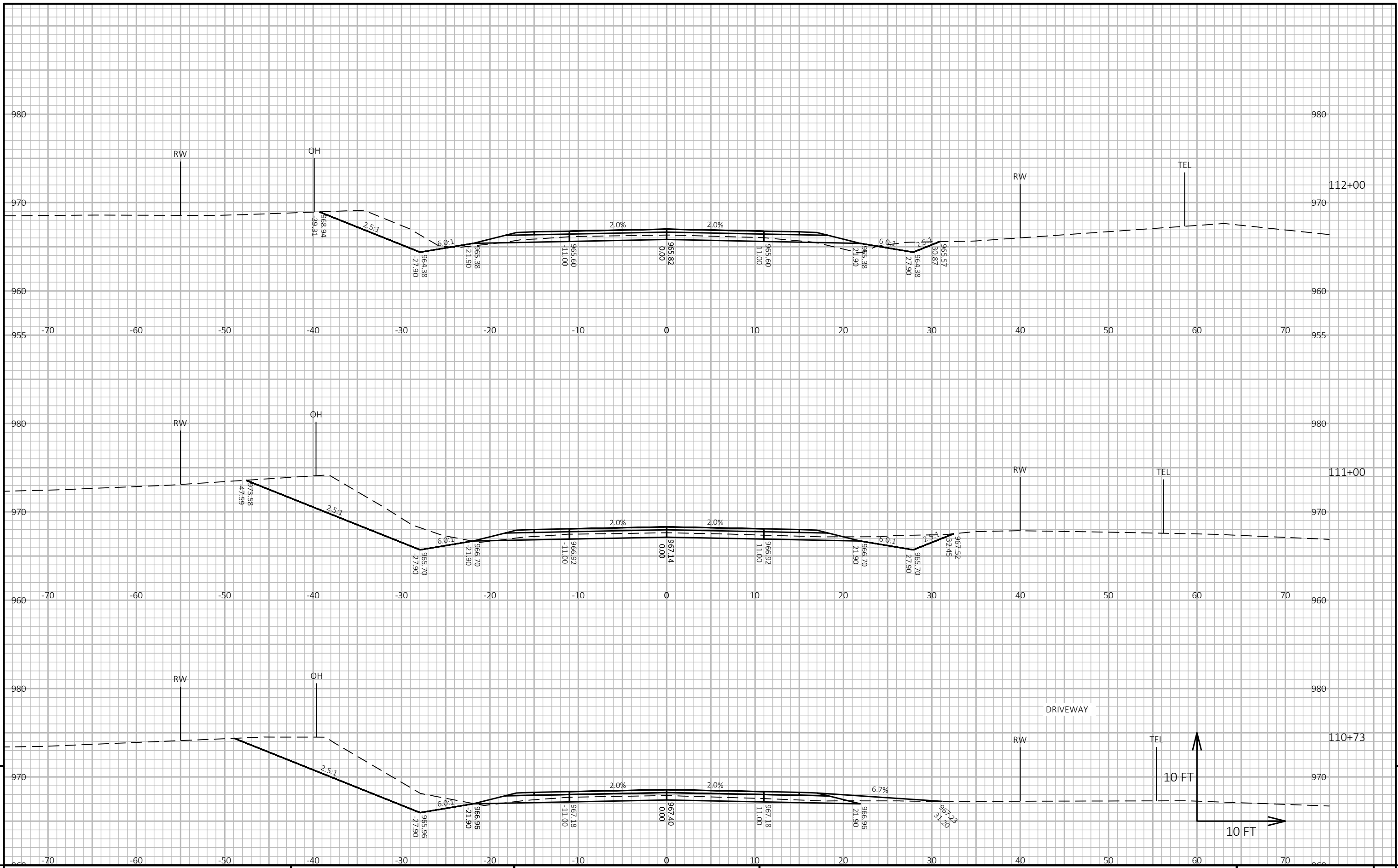

PROJECT NO: 7880-07-73 HWY: CTH H COUNTY: DUNN CROSS SECTIONS: CTH H SHEET E

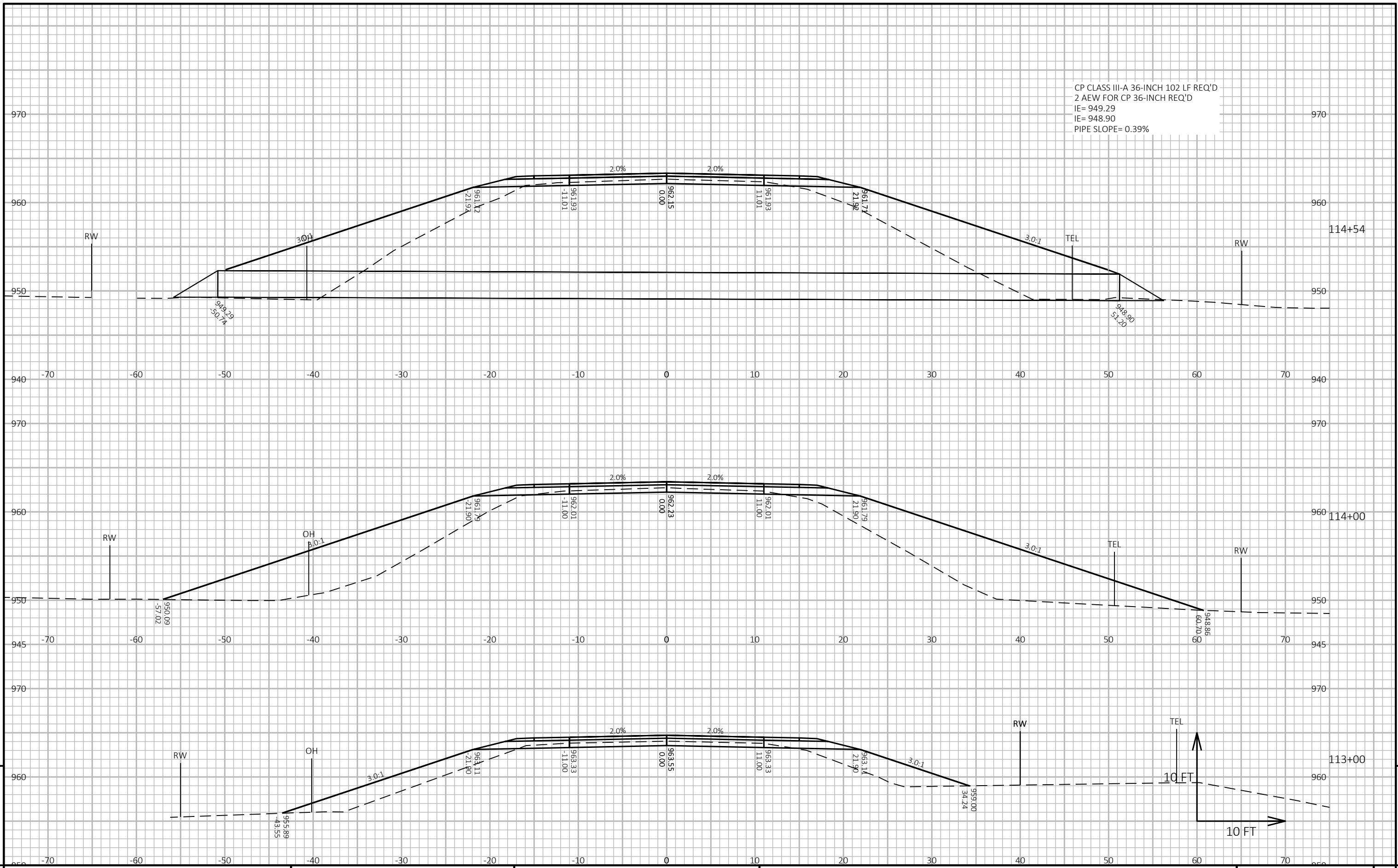

PROJECT NO: 7880-07-73 HWY: CTH H COUNTY: DUNN CROSS SECTIONS: CTH H SHEET E

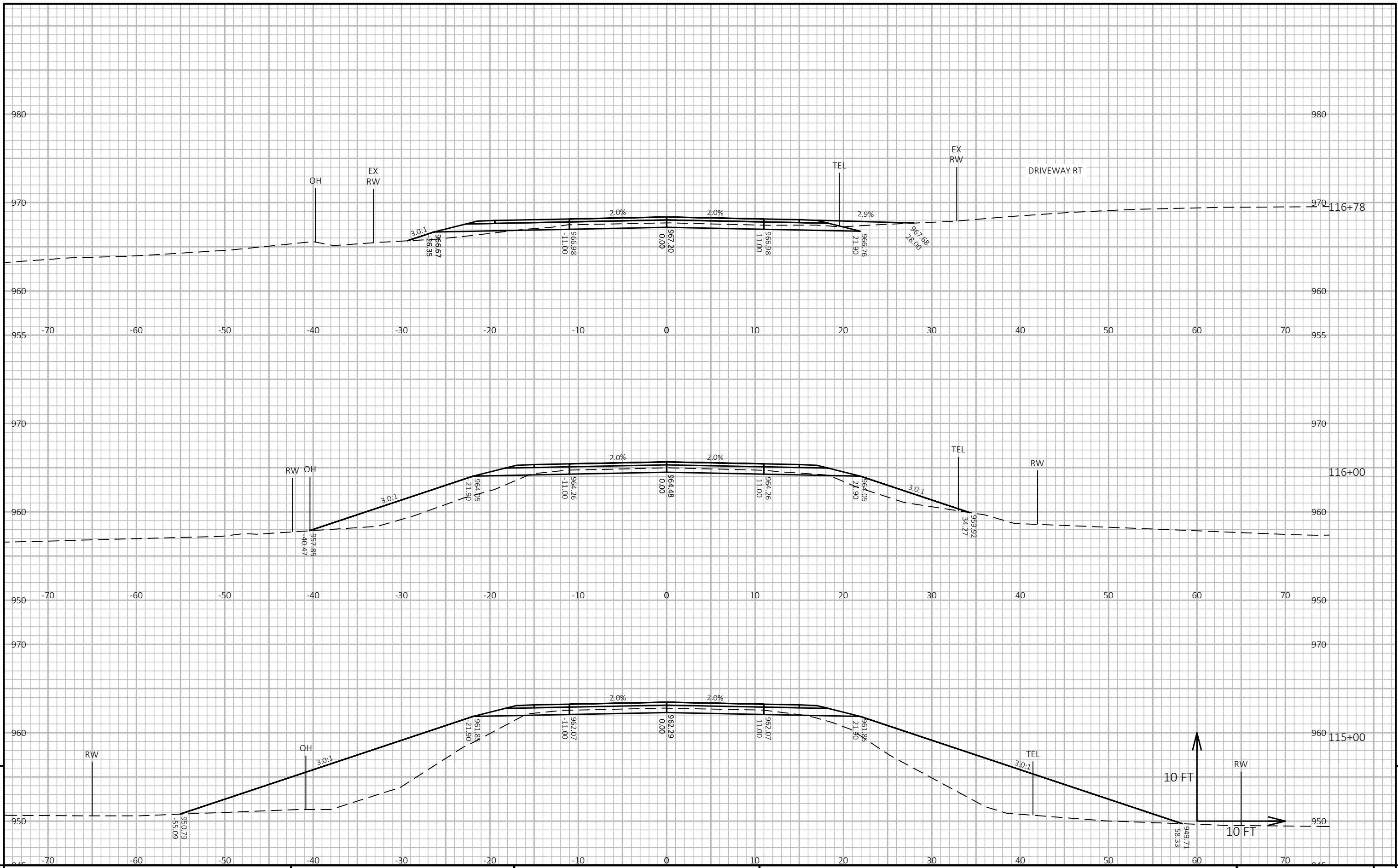

PROJECT NO: 7880-07-73	HWY: CTH H	COUNTY: DUNN	CROSS SECTIONS: CTH H	SHEET 9
------------------------	------------	--------------	-----------------------	---------

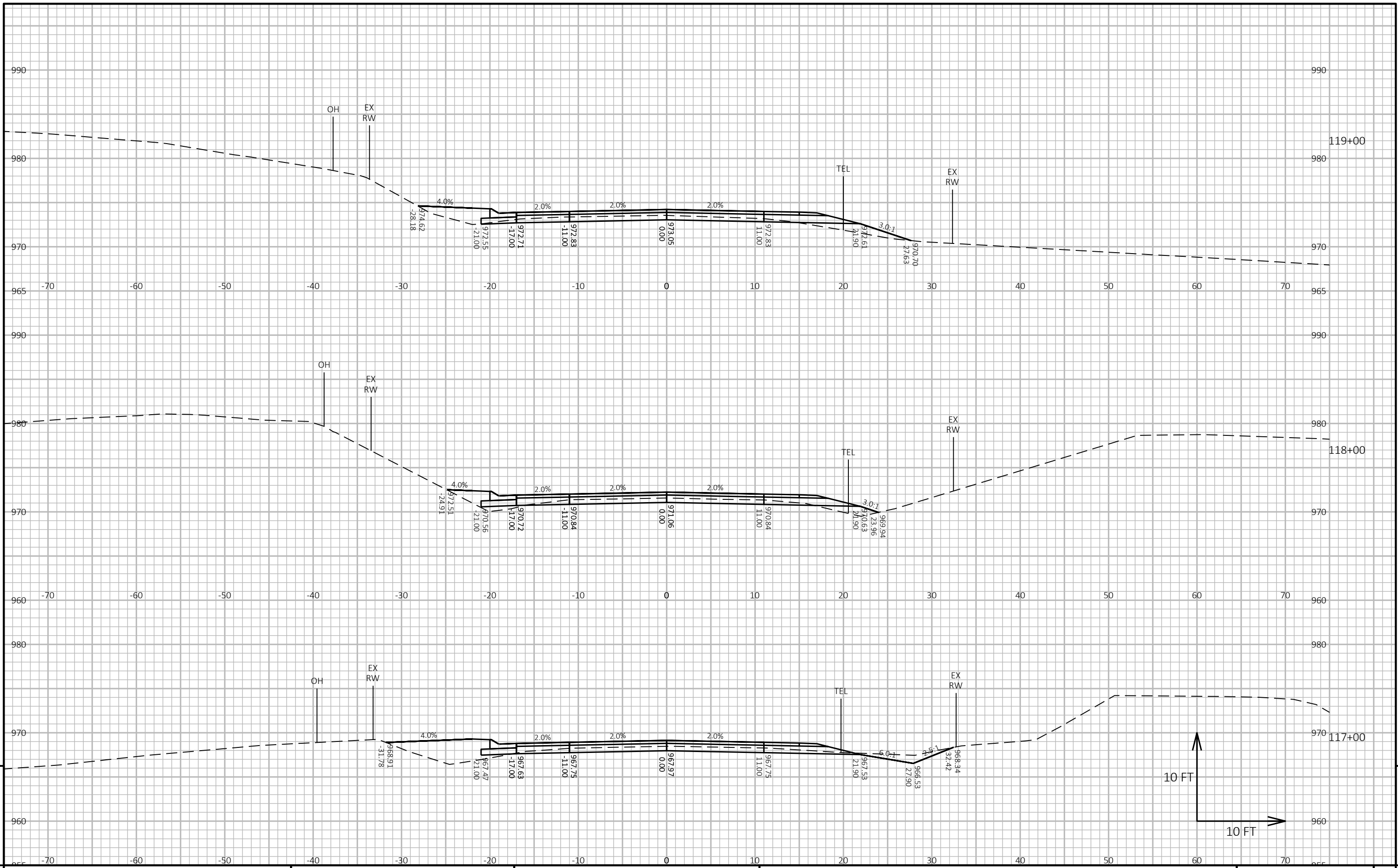

PROJECT NO: 7880-07-73 HWY: CTH H COUNTY: DUNN CROSS SECTIONS: CTH H SHEET E

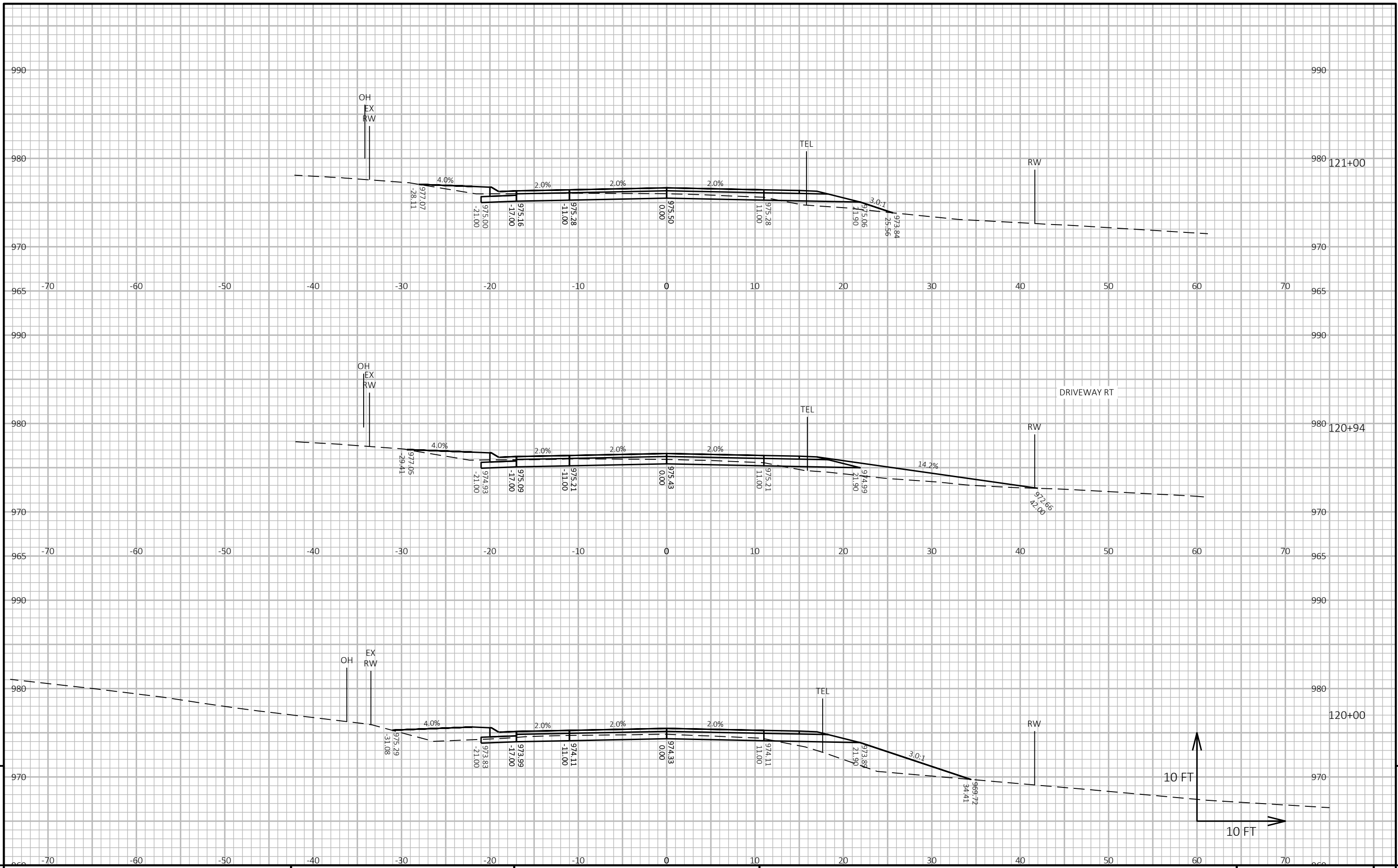

9

9

PROJECT NO: 7880-07-73 HWY: CTH H COUNTY: DUNN CROSS SECTIONS: CTH H SHEET E

FILE NAME: C:\OD\CORRE, INC\PROJECTS - DOCUMENTS\WI - NW REGION\7880-07-03_DUNN CO_CTH H\500_CADD\501_C3D_2018\78800703\SHEETS\PLAN\090201-XS.DWG PLOT DATE: 10/14/2021 2:53 PM PLOT BY: NICHOLAS WATHKE PLOT NAME: PLOT SCALE: 1 IN:10 FT HORZ. / 1 IN:10 FT VERT. WISDOT/CADD SHEET 49

LAYOUT NAME - 9

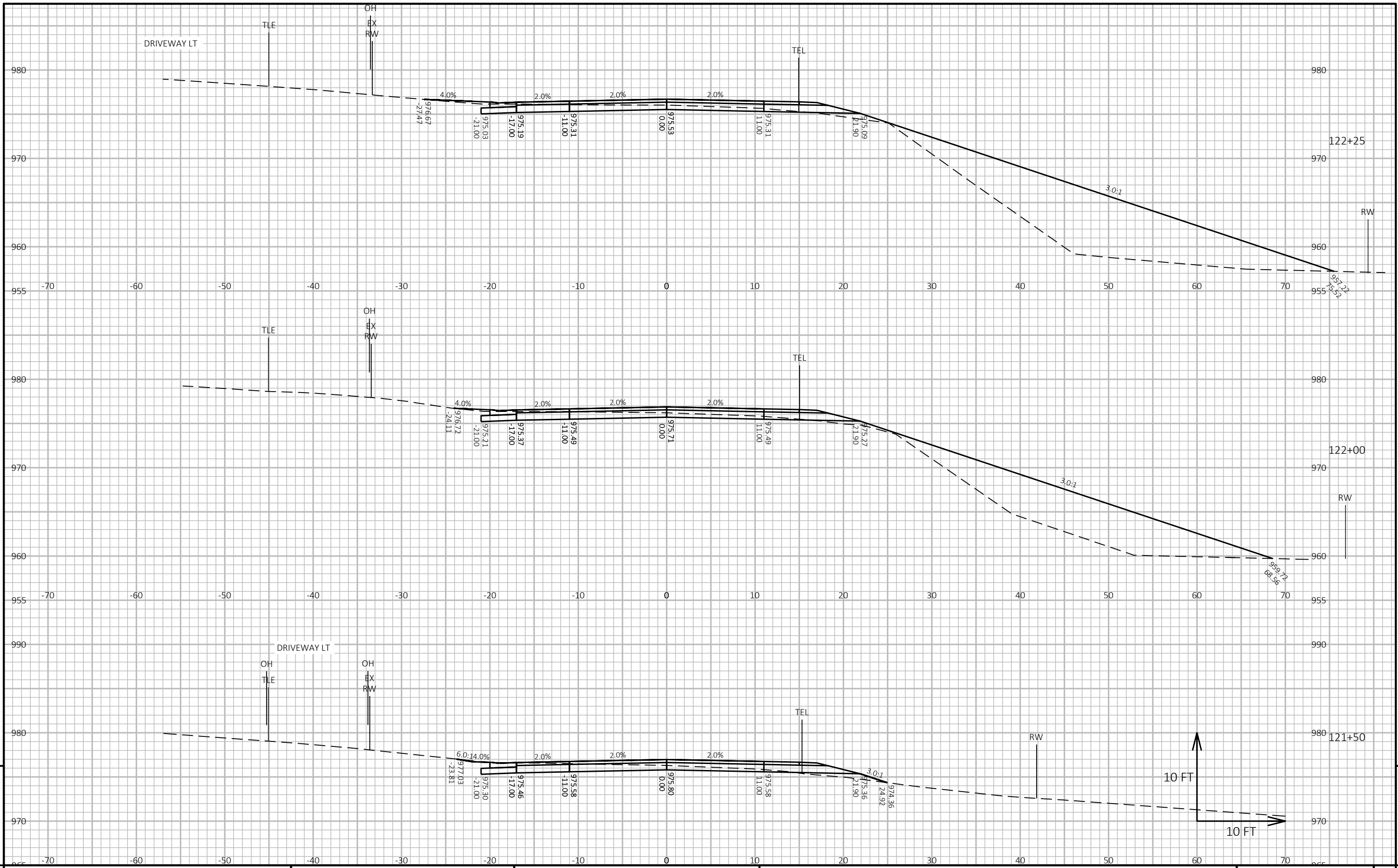

PROJECT NO: 7880-07-73 HWY: CTH H COUNTY: DUNN CROSS SECTIONS: CTH H SHEET E

9

9

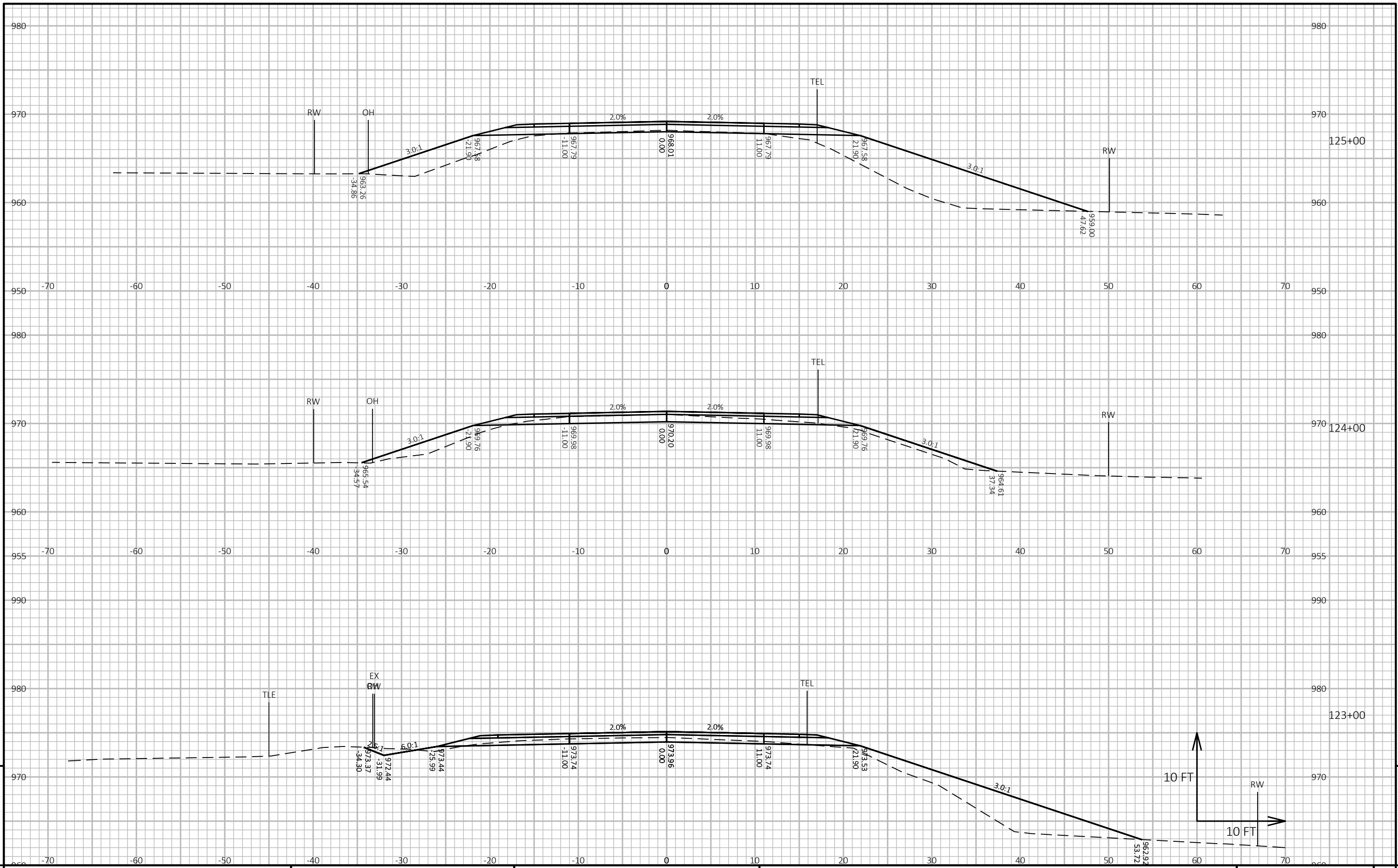

9

9

PROJECT NO: 7880-07-73 HWY: CTH H COUNTY: DUNN CROSS SECTIONS: CTH H SHEET E

FILE NAME : C:\OD\CORRE, INC\PROJECTS - DOCUMENTS\WI - NW REGION\7880-07-03_DUNN CO_CTH H\500_CADD\501_C3D_2018\78800703\SHEETS\PLAN\090201-XS.DWG PLOT DATE : 10/14/2021 2:54 PM PLOT BY : NICHOLAS WATHKE PLOT NAME : PLOT SCALE : 1 IN:10 FT HORZ. / 1 IN:10 FT VERT. WISDOT/CADD SHEET 49

LAYOUT NAME - 11

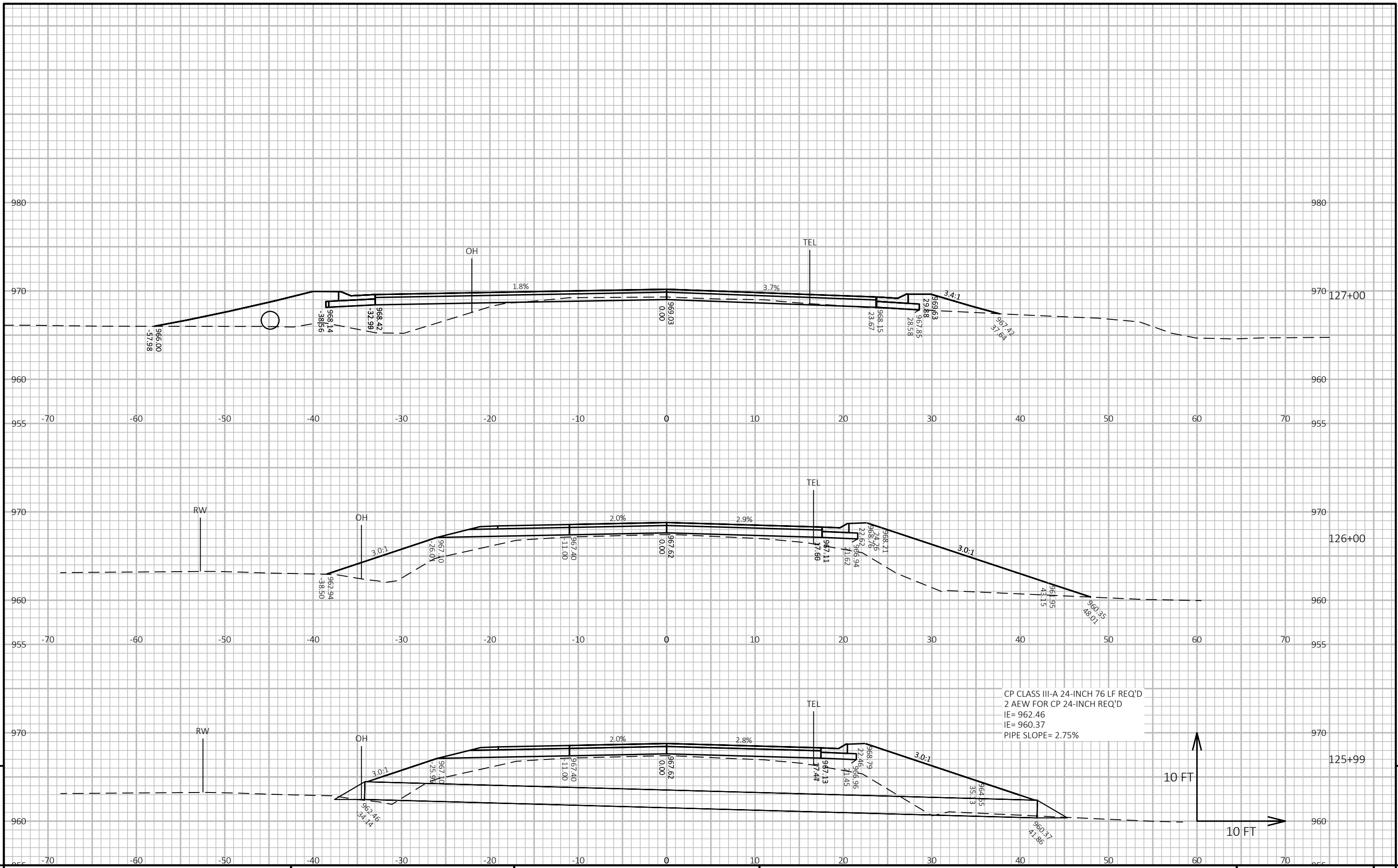

CP CLASS III-A 24-INCH 76 LF REQ'D
 2 AEW FOR CP 24-INCH REQ'D
 IE= 962.46
 IE= 960.37
 PIPE SLOPE= 2.75%

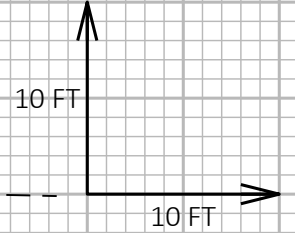

PROJECT NO: 7880-07-73	HWY: CTH H	COUNTY: DUNN	CROSS SECTIONS: CTH H	SHEET	E
------------------------	------------	--------------	-----------------------	-------	---

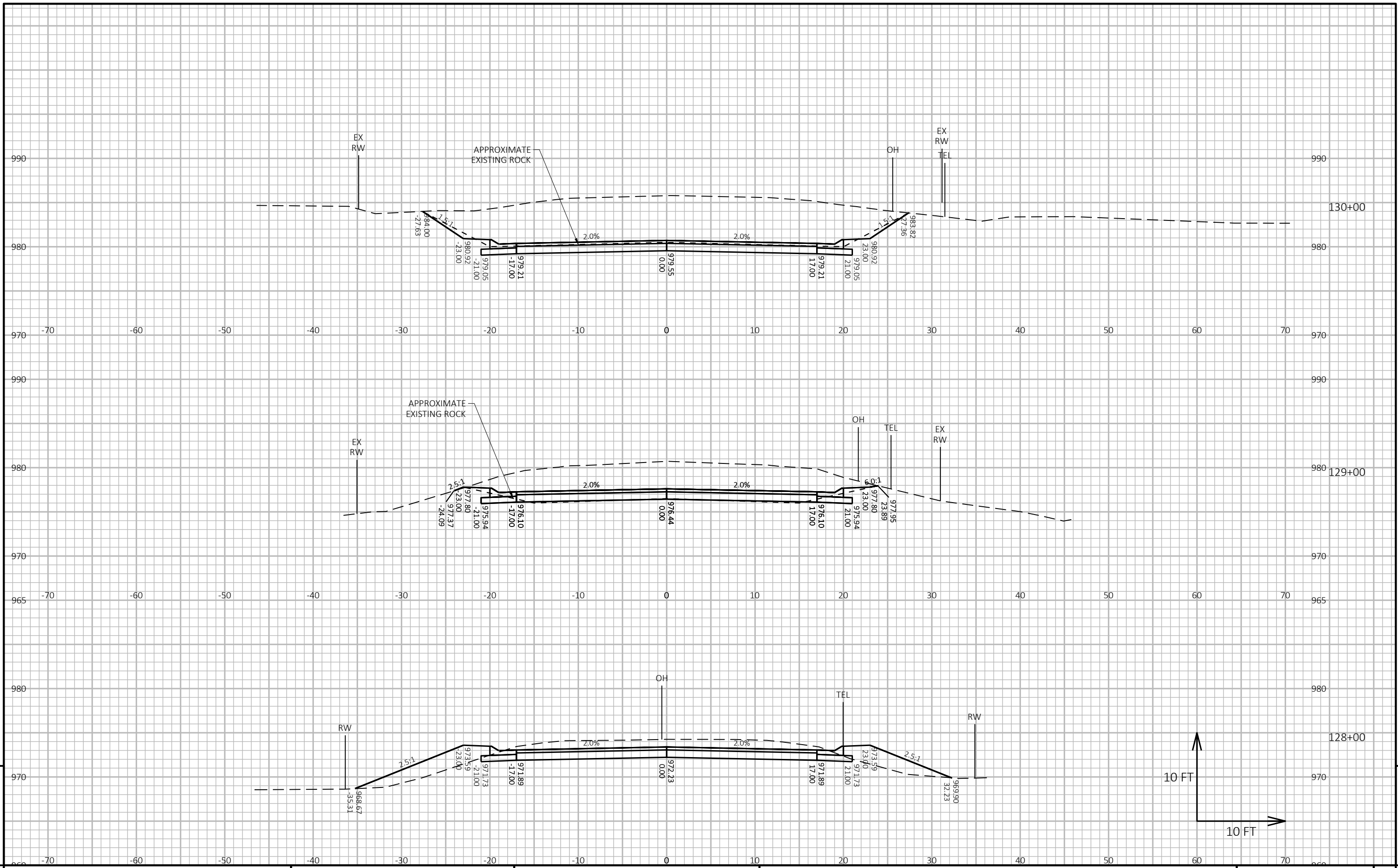

PROJECT NO: 7880-07-73 HWY: CTH H COUNTY: DUNN CROSS SECTIONS: CTH H SHEET E

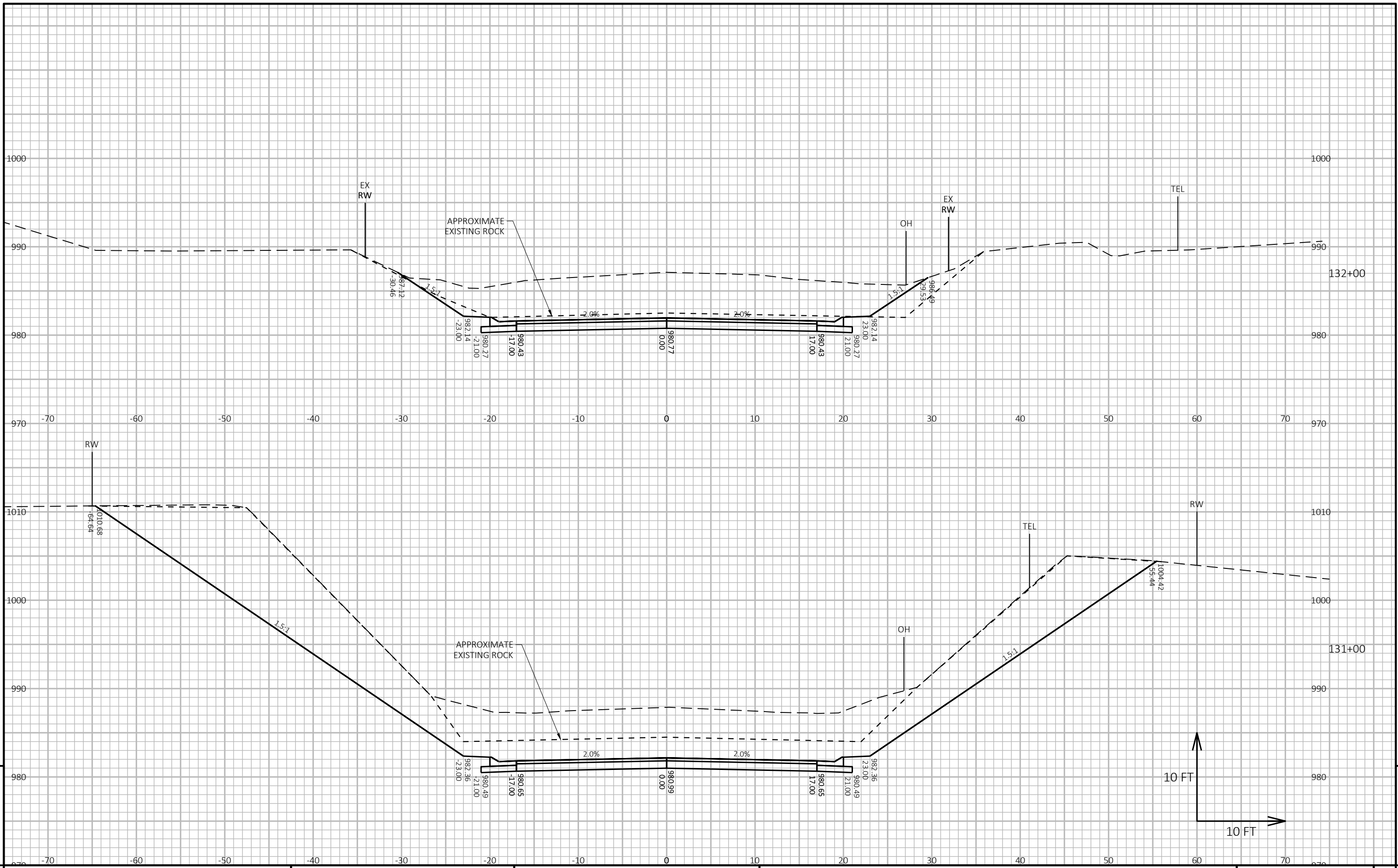

PROJECT NO: 7880-07-73 HWY: CTH H COUNTY: DUNN CROSS SECTIONS: CTH H SHEET E

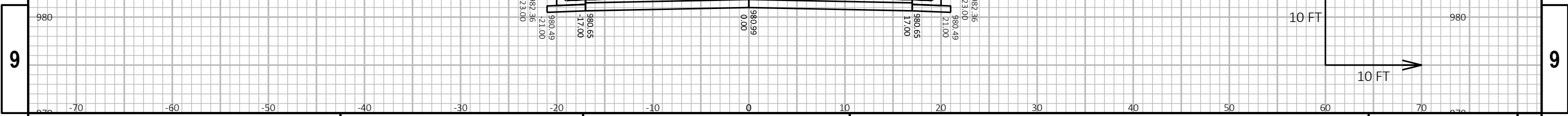

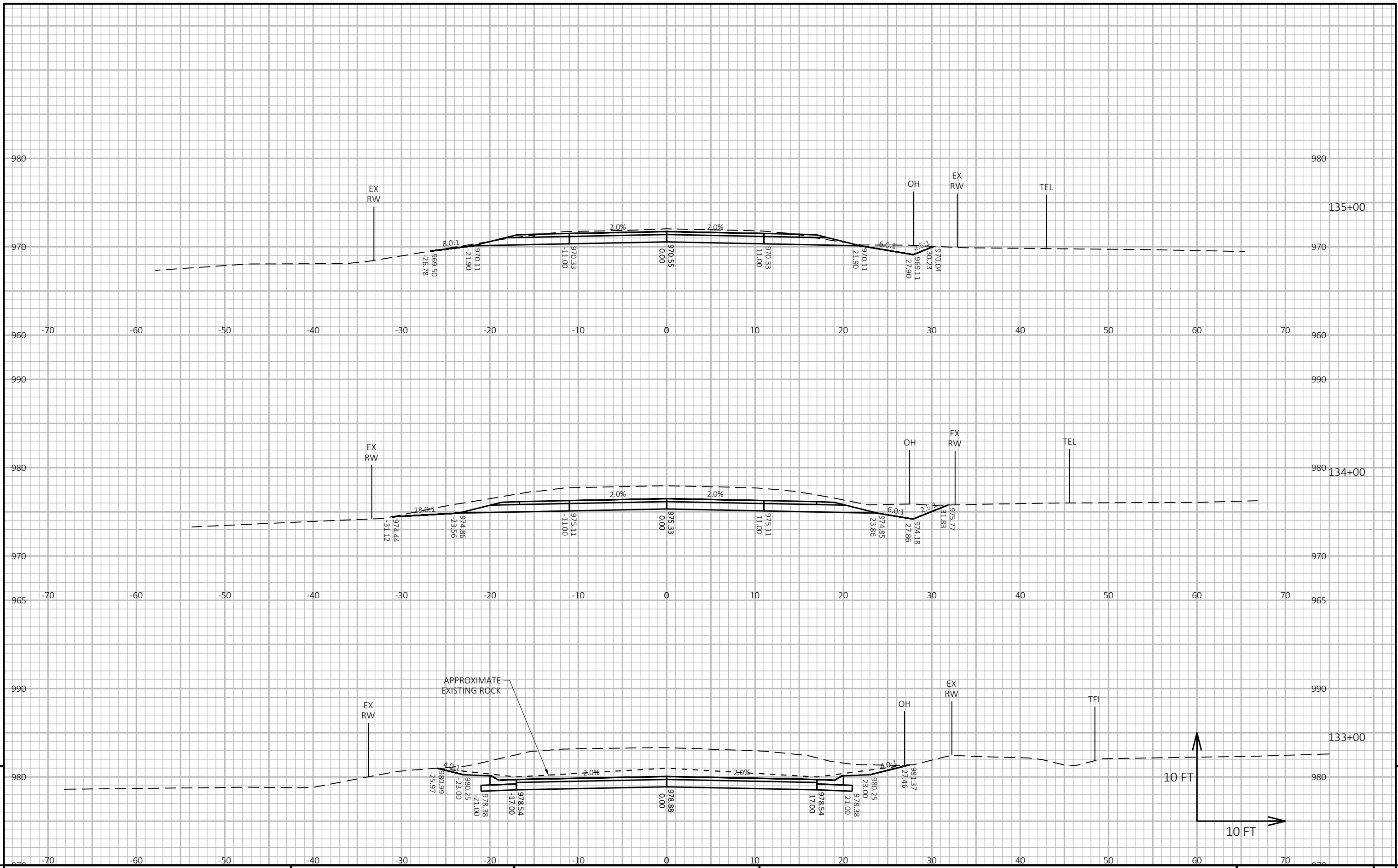

PROJECT NO: 7880-07-73 HWY: CTH H COUNTY: DUNN CROSS SECTIONS: CTH H SHEET E

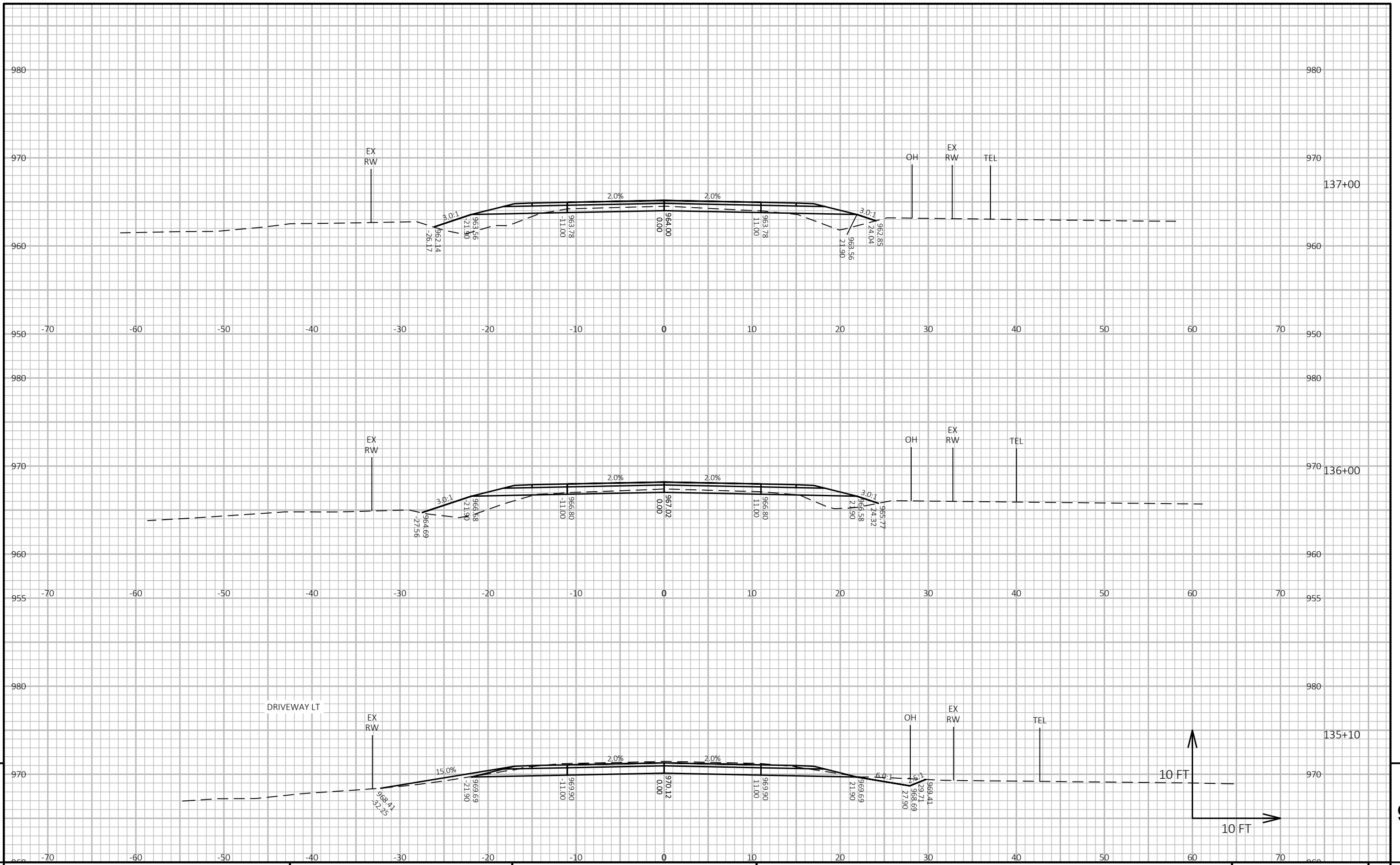

PROJECT NO: 7880-07-73	HWY: CTH H	COUNTY: DUNN	CROSS SECTIONS: CTH H	SHEET E
------------------------	------------	--------------	-----------------------	---------

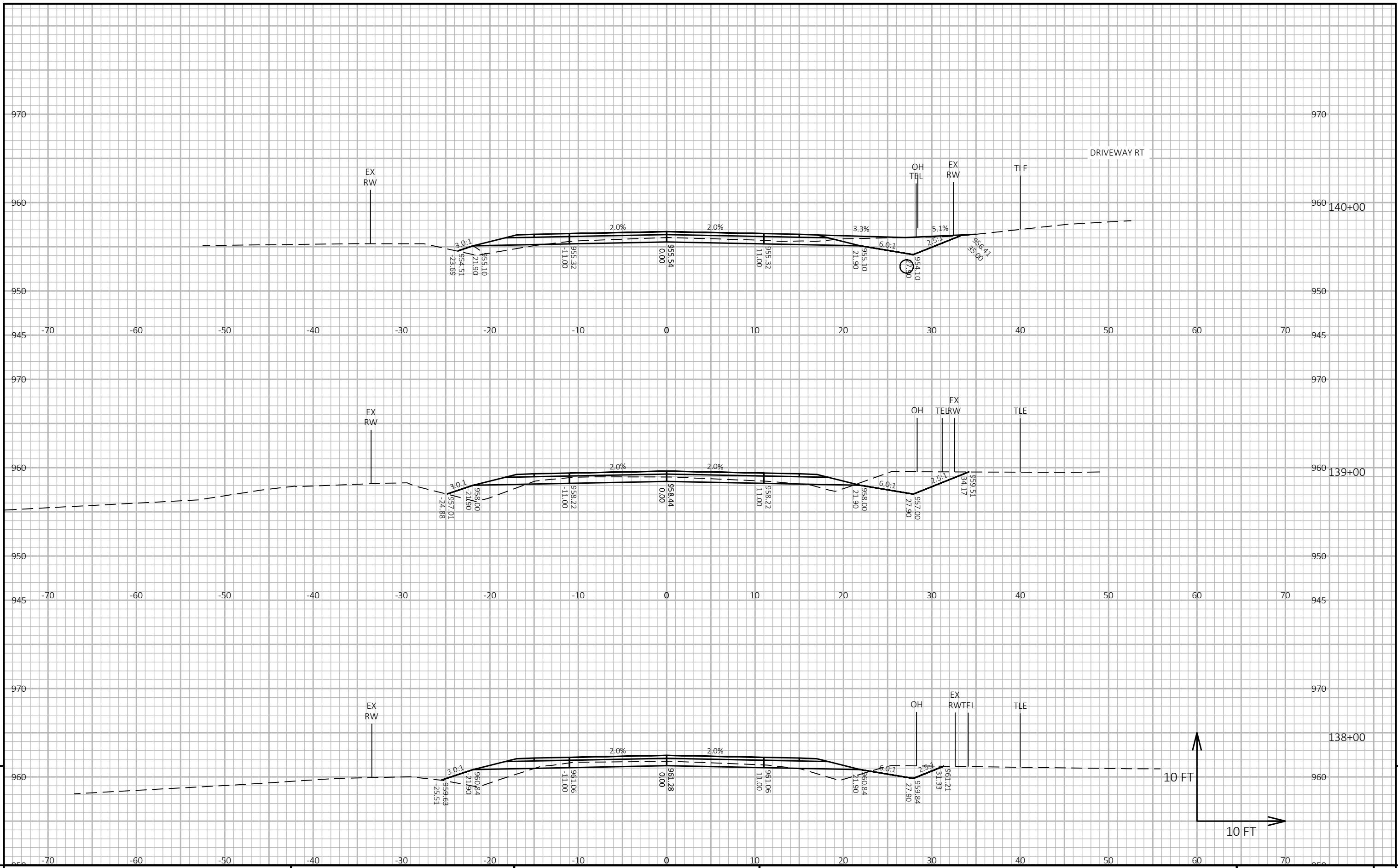

PROJECT NO: 7880-07-73 HWY: CTH H COUNTY: DUNN CROSS SECTIONS: CTH H SHEET E

9

9

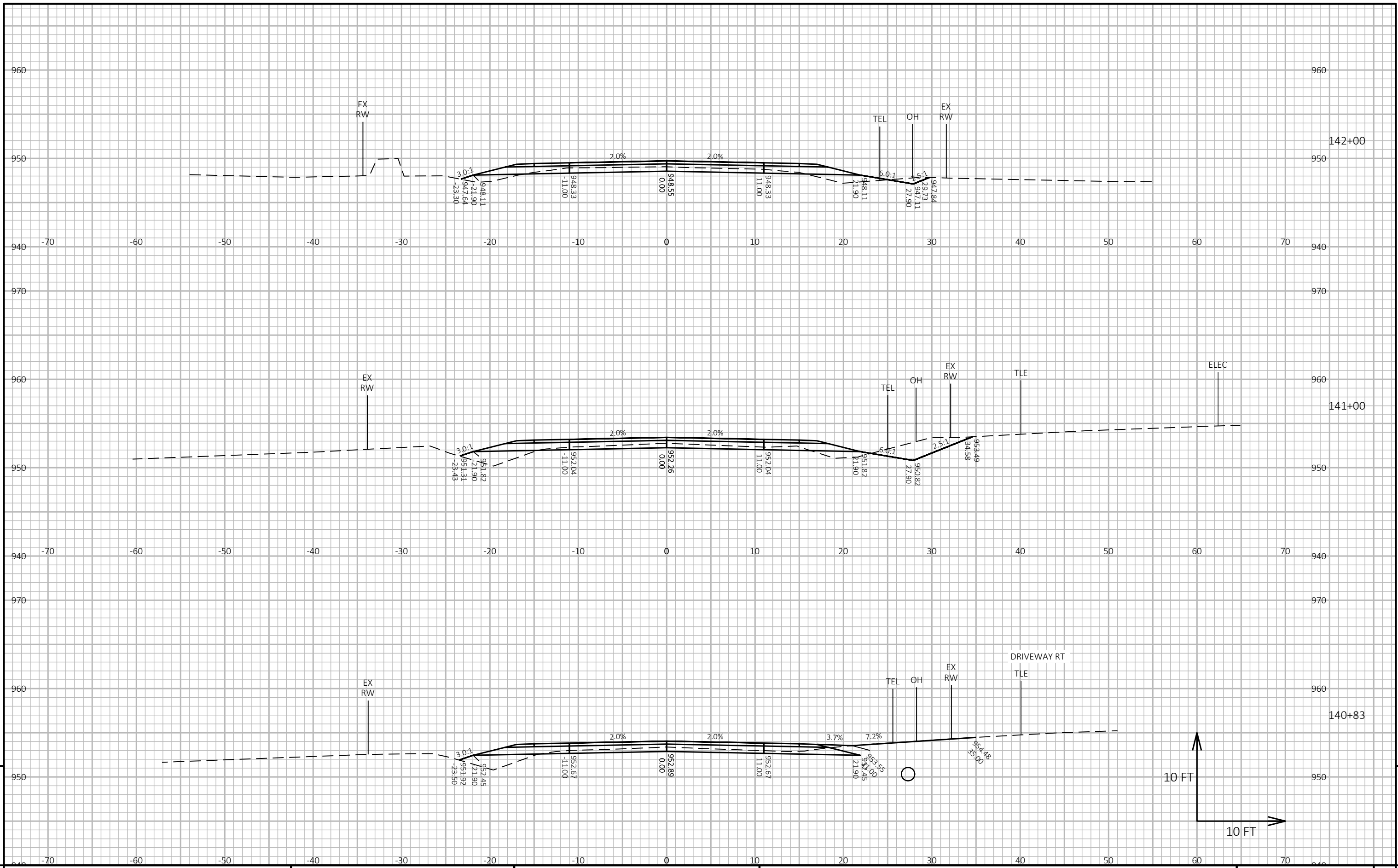

9

9

PROJECT NO: 7880-07-73 HWY: CTH H COUNTY: DUNN CROSS SECTIONS: CTH H SHEET E

FILE NAME : C:\OD\CORRE, INC\PROJECTS - DOCUMENTS\WI - NW REGION\7880-07-03_DUNN CO_CTH H\500_CADD\501_C3D_2018\78800703\SHEETS\PLAN\090201-XS.DWG PLOT DATE : 10/14/2021 2:56 PM PLOT BY : NICHOLAS WATKHE PLOT NAME : PLOT SCALE : 1 IN:10 FT HORZ. / 1 IN:10 FT VERT. WISDOT/CADD SHEET 49

LAYOUT NAME - 18

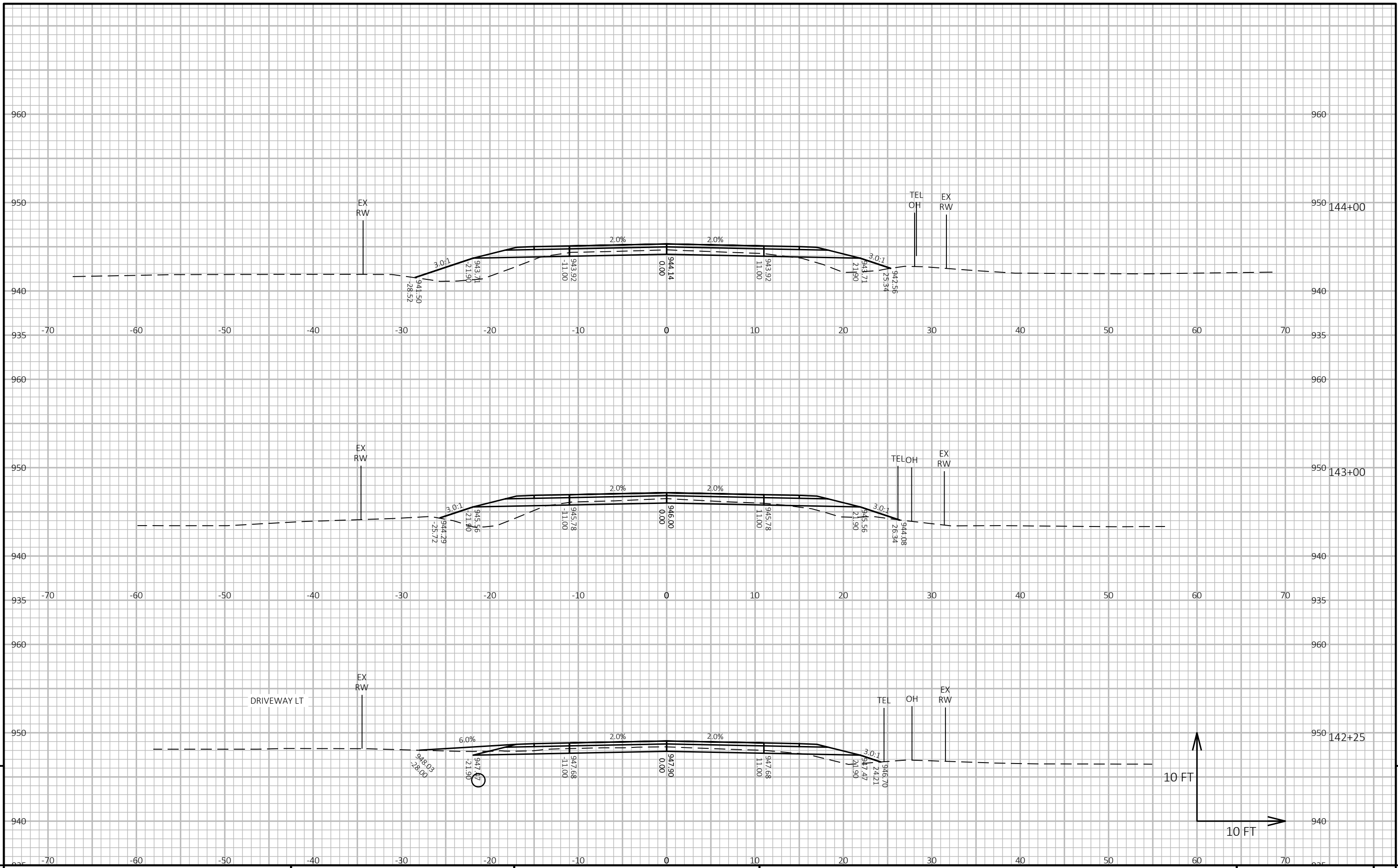

PROJECT NO: 7880-07-73 HWY: CTH H COUNTY: DUNN CROSS SECTIONS: CTH H SHEET E

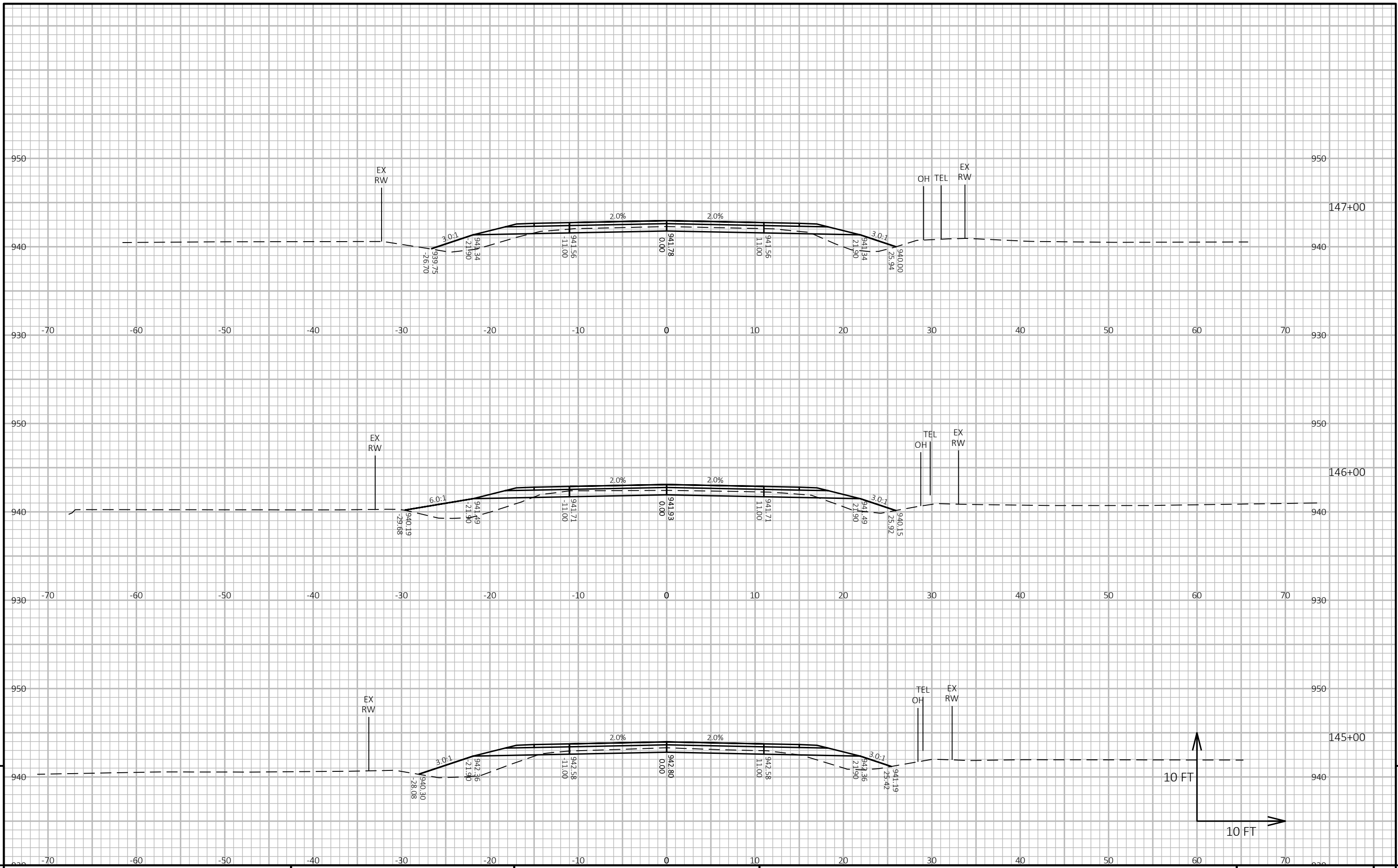

9 9

PROJECT NO: 7880-07-73 HWY: CTH H COUNTY: DUNN CROSS SECTIONS: CTH H SHEET E

FILE NAME: C:\OD\CORRE, INC\PROJECTS - DOCUMENTS\WI - NW REGION\7880-07-03_DUNN CO_CTH H\500_CADD\501_C3D_2018\78800703\SHEETS\PLAN\090201-XS.DWG PLOT DATE: 10/14/2021 2:56 PM PLOT BY: NICHOLAS WATHKE PLOT NAME: PLOT SCALE: 1 IN:10 FT HORZ. / 1 IN:10 FT VERT. WISDOT/CADD SHEET 49

LAYOUT NAME - 20

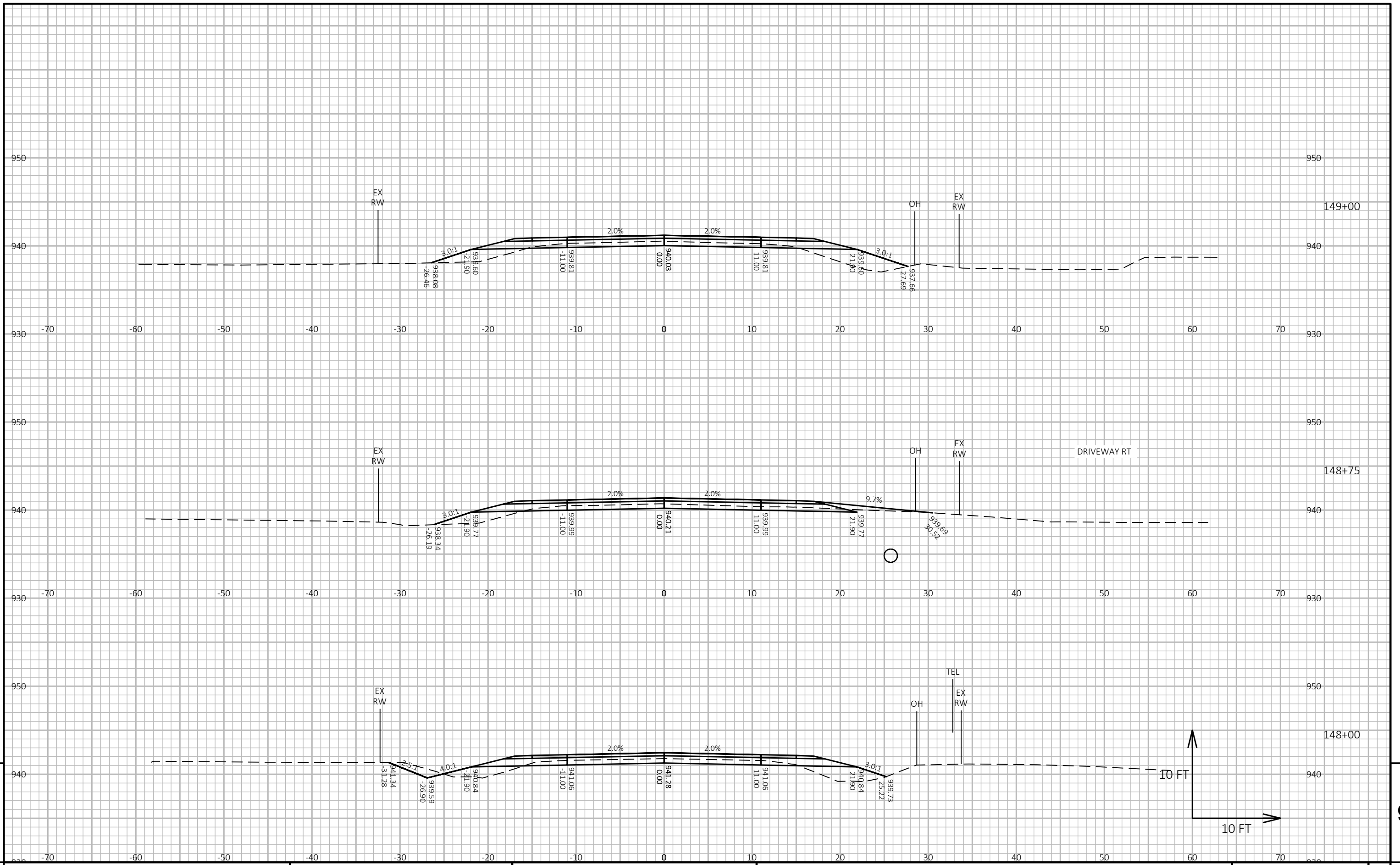

PROJECT NO: 7880-07-73 HWY: CTH H COUNTY: DUNN CROSS SECTIONS: CTH H SHEET E

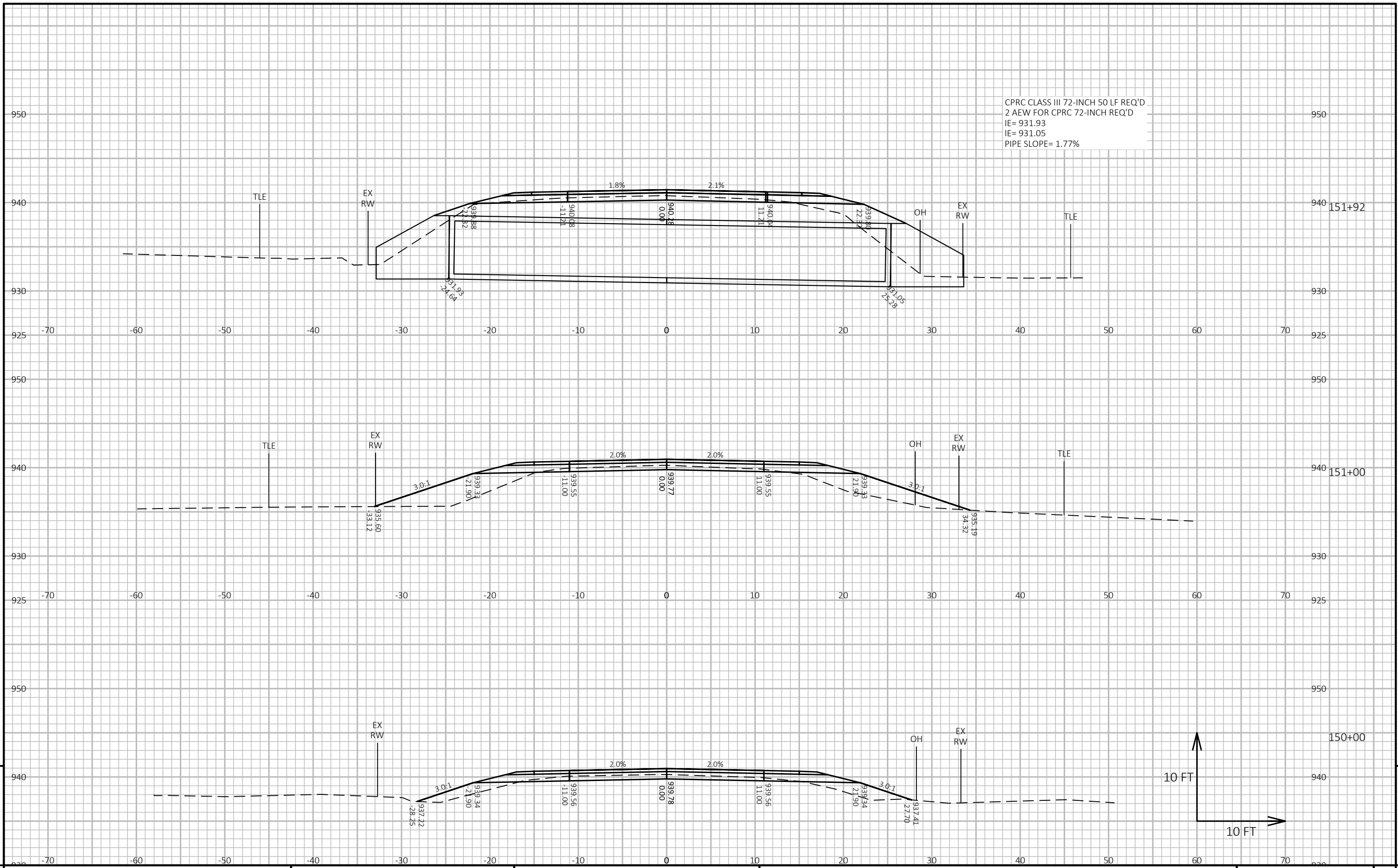

9

9

PROJECT NO: 7880-07-73 HWY: CTH H COUNTY: DUNN CROSS SECTIONS: CTH H SHEET E

FILE NAME : C:\OD\CORRE, INC\PROJECTS - DOCUMENTS\WI - NW REGION\7880-07-03_DUNN CO_CTH H\500_CADD\501_C3D_2018\78800703\SHEETS\PLAN\090201-XS.DWG PLOT DATE : 10/14/2021 2:57 PM PLOT BY : NICHOLAS WATKKE PLOT NAME : PLOT SCALE : 1 IN:10 FT HORZ. / 1 IN:10 FT VERT. WISDOT/CADD SHEET 49

LAYOUT NAME - 22

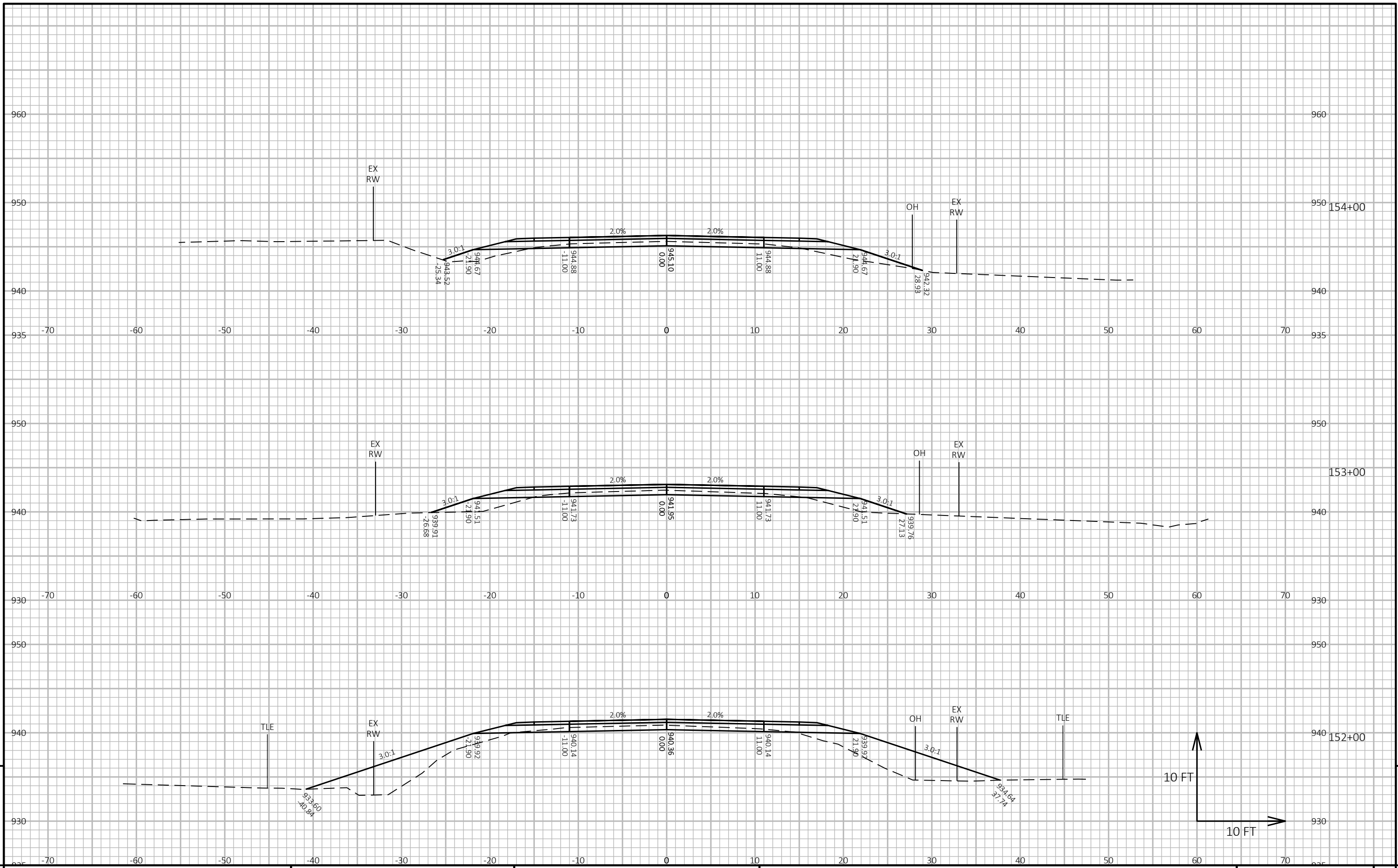

9

9

PROJECT NO: 7880-07-73 HWY: CTH H COUNTY: DUNN CROSS SECTIONS: CTH H SHEET E

FILE NAME : C:\OD\CORRE, INC\PROJECTS - DOCUMENTS\WI - NW REGION\7880-07-03_DUNN CO_CTH H\500_CADD\501_C3D_2018\78800703\SHEETS\PLAN\090201-XS.DWG PLOT DATE : 10/14/2021 2:57 PM PLOT BY : NICHOLAS WATKHE PLOT NAME : PLOT SCALE : 1 IN:10 FT HORZ. / 1 IN:10 FT VERT. WISDOT/CADD SHEET 49

LAYOUT NAME - 23

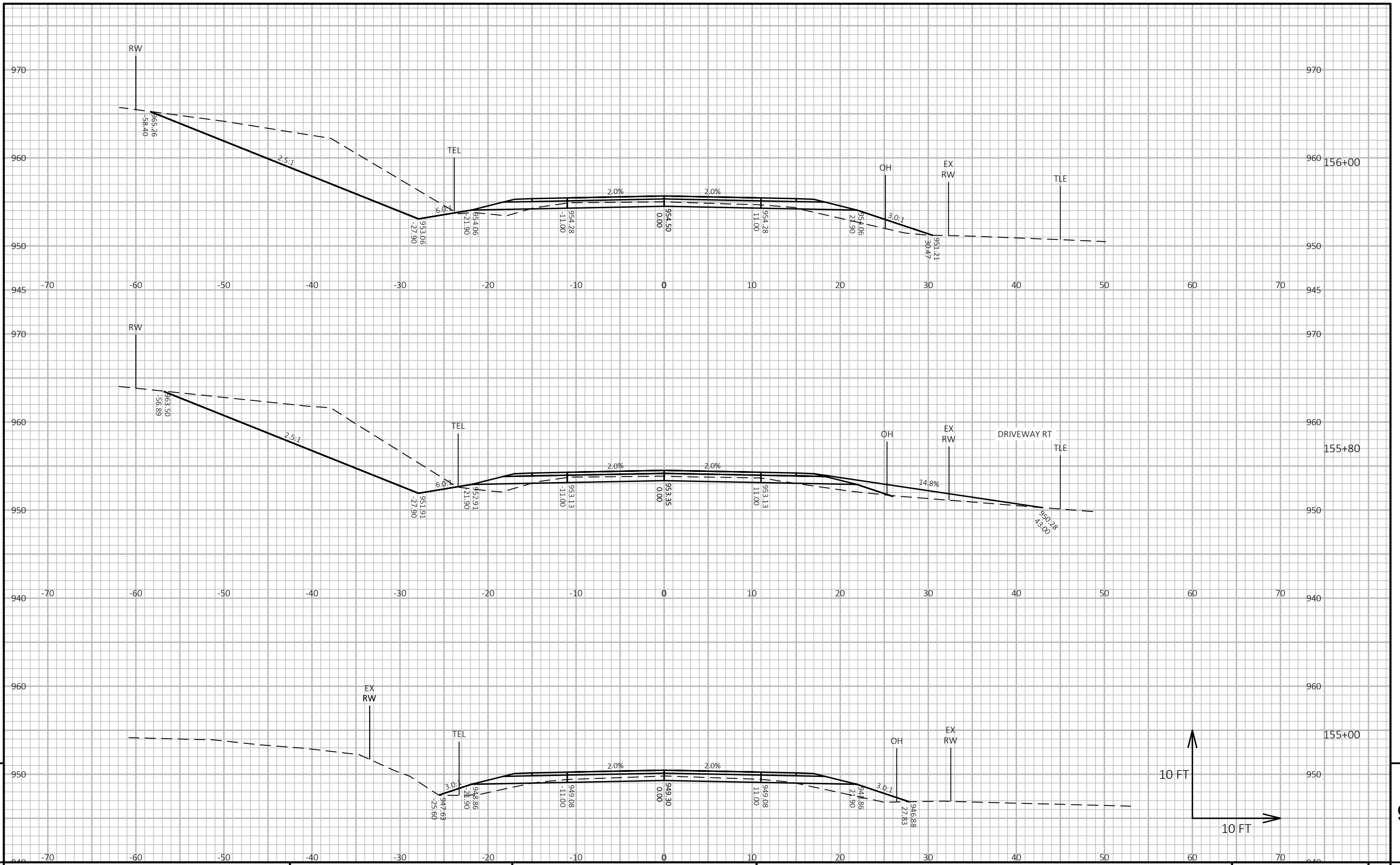

PROJECT NO: 7880-07-73 HWY: CTH H COUNTY: DUNN CROSS SECTIONS: CTH H SHEET E

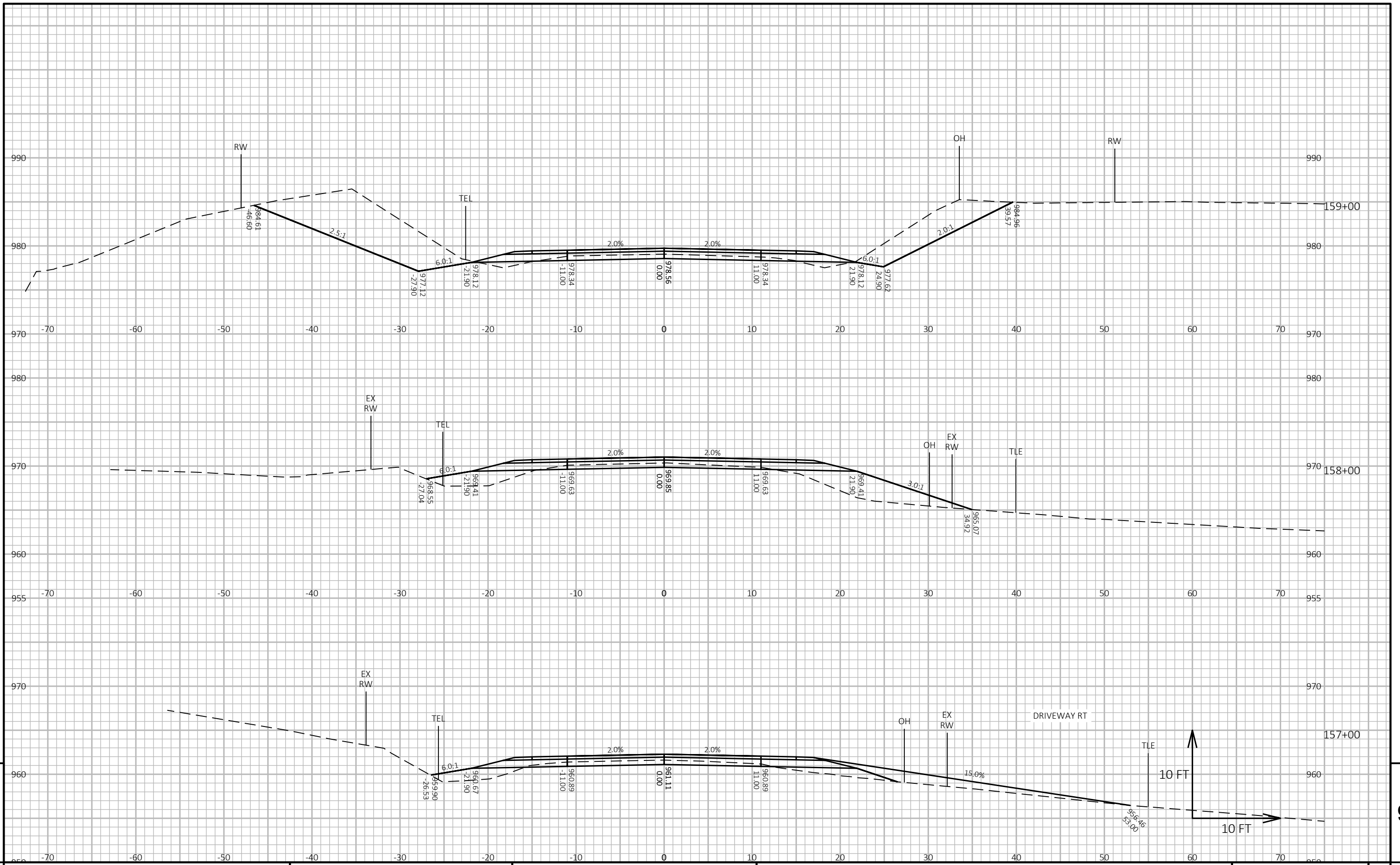

PROJECT NO: 7880-07-73

HWY: CTH H

COUNTY: DUNN

CROSS SECTIONS: CTH H

SHEET

E

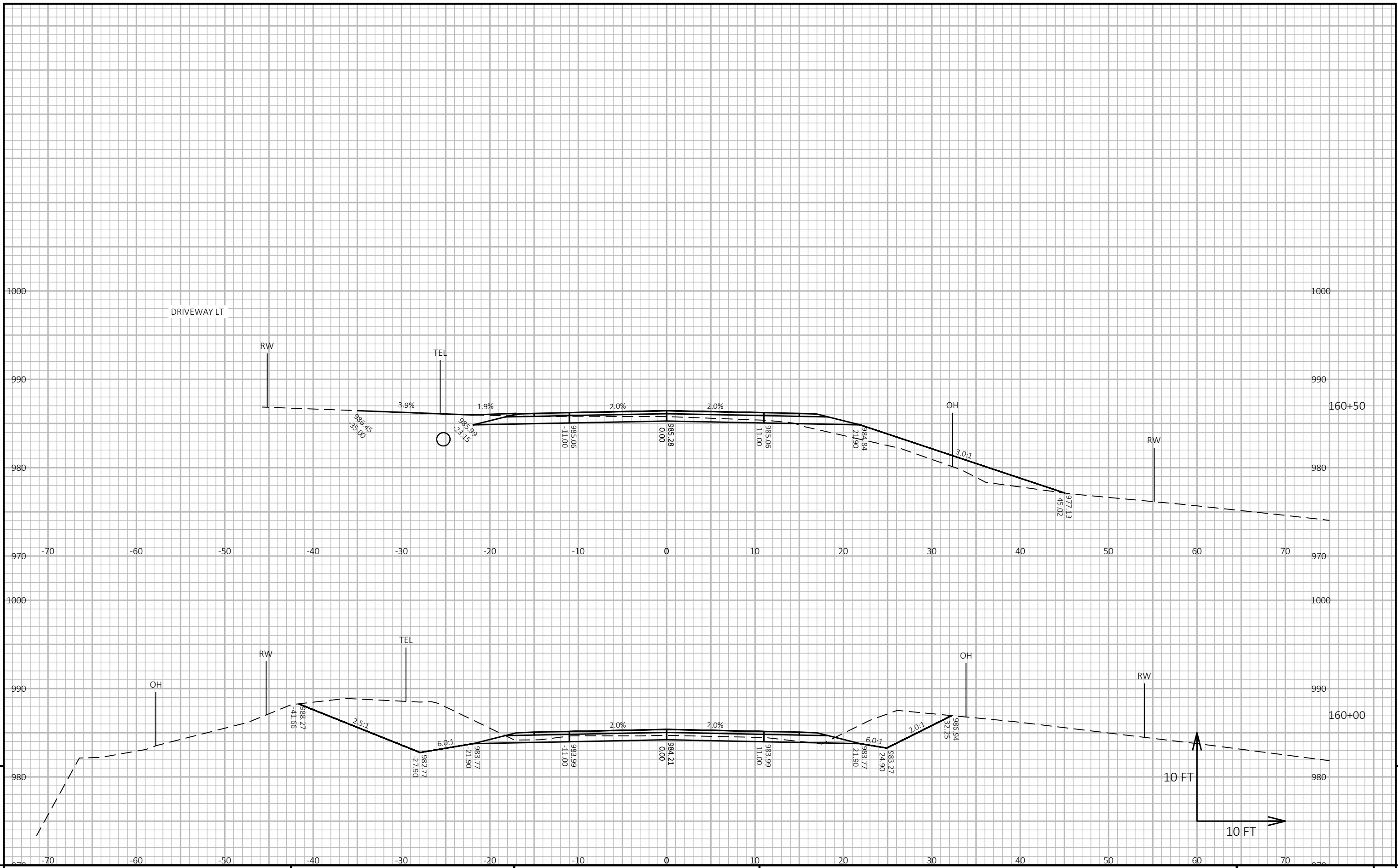

PROJECT NO: 7880-07-73

HWY: CTH H

COUNTY: DUNN

CROSS SECTIONS: CTH H

SHEET

E

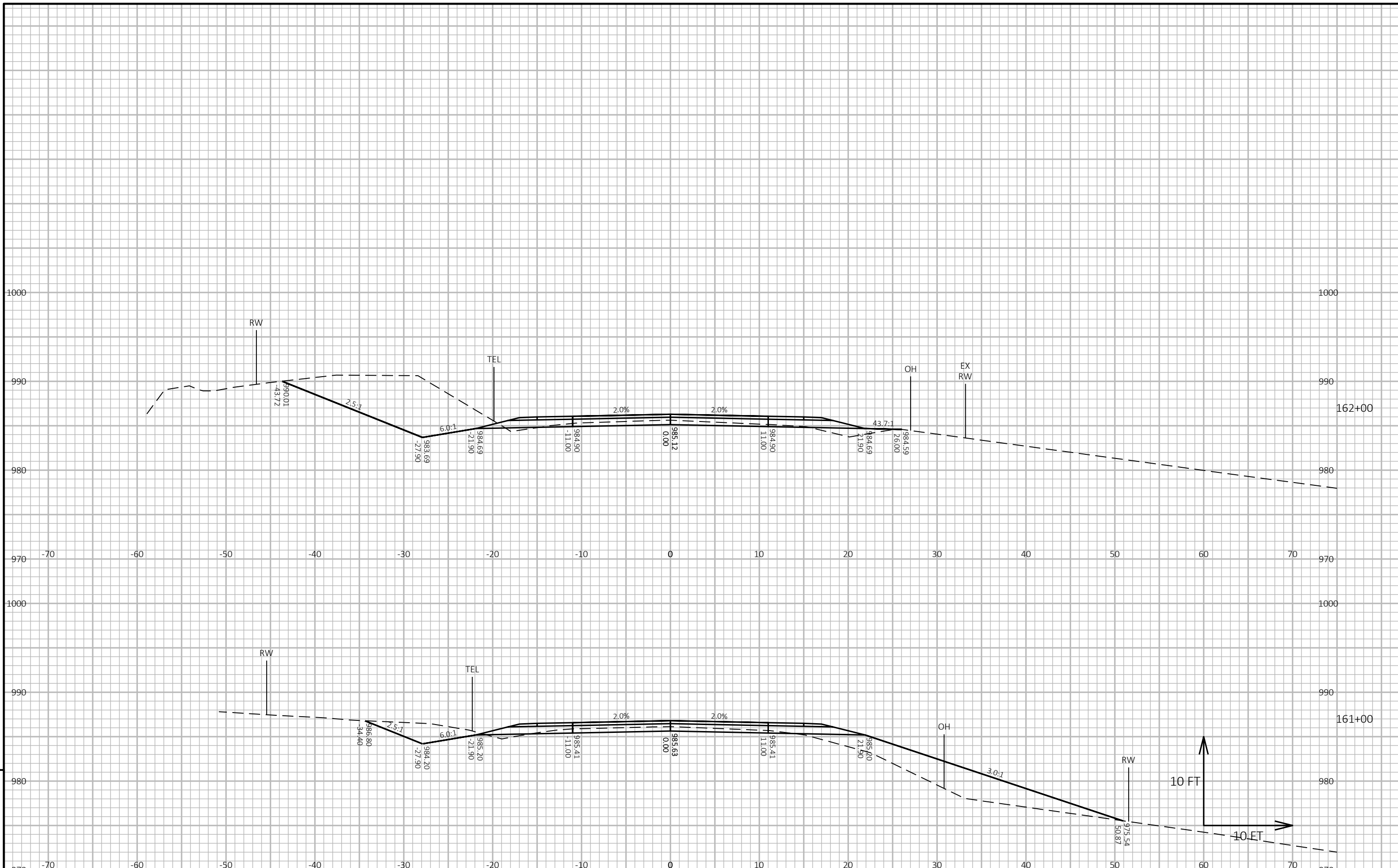

PROJECT NO: 7880-07-73

HWY: CTH H

COUNTY: DUNN

CROSS SECTIONS: CTH H

SHEET

E

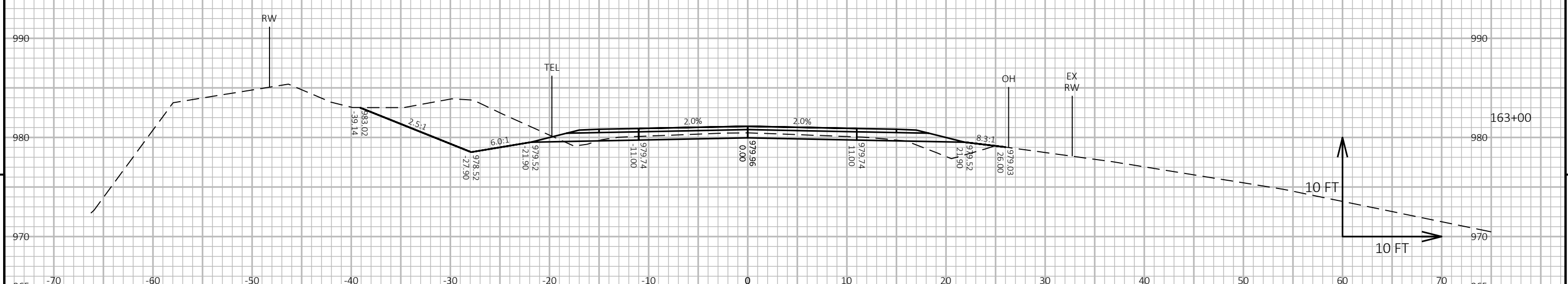
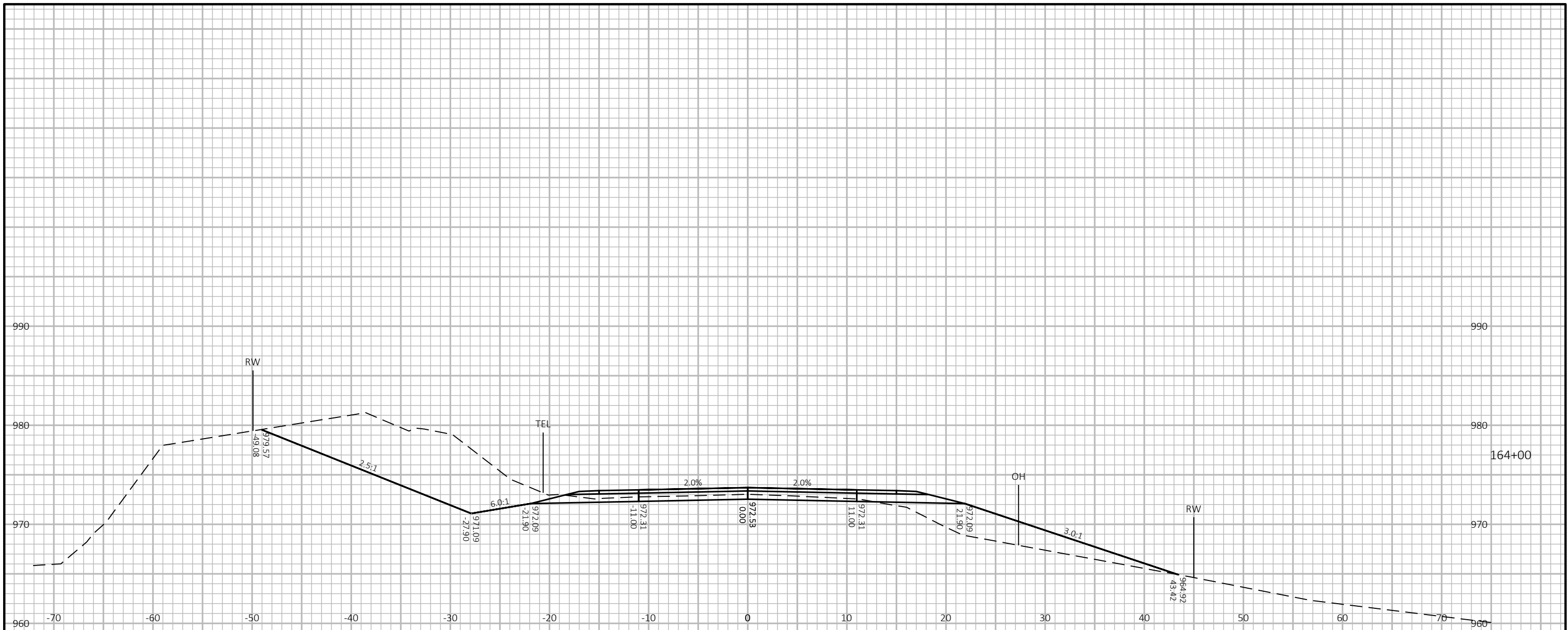

PROJECT NO: 7880-07-73 HWY: CTH H COUNTY: DUNN CROSS SECTIONS: CTH H SHEET E

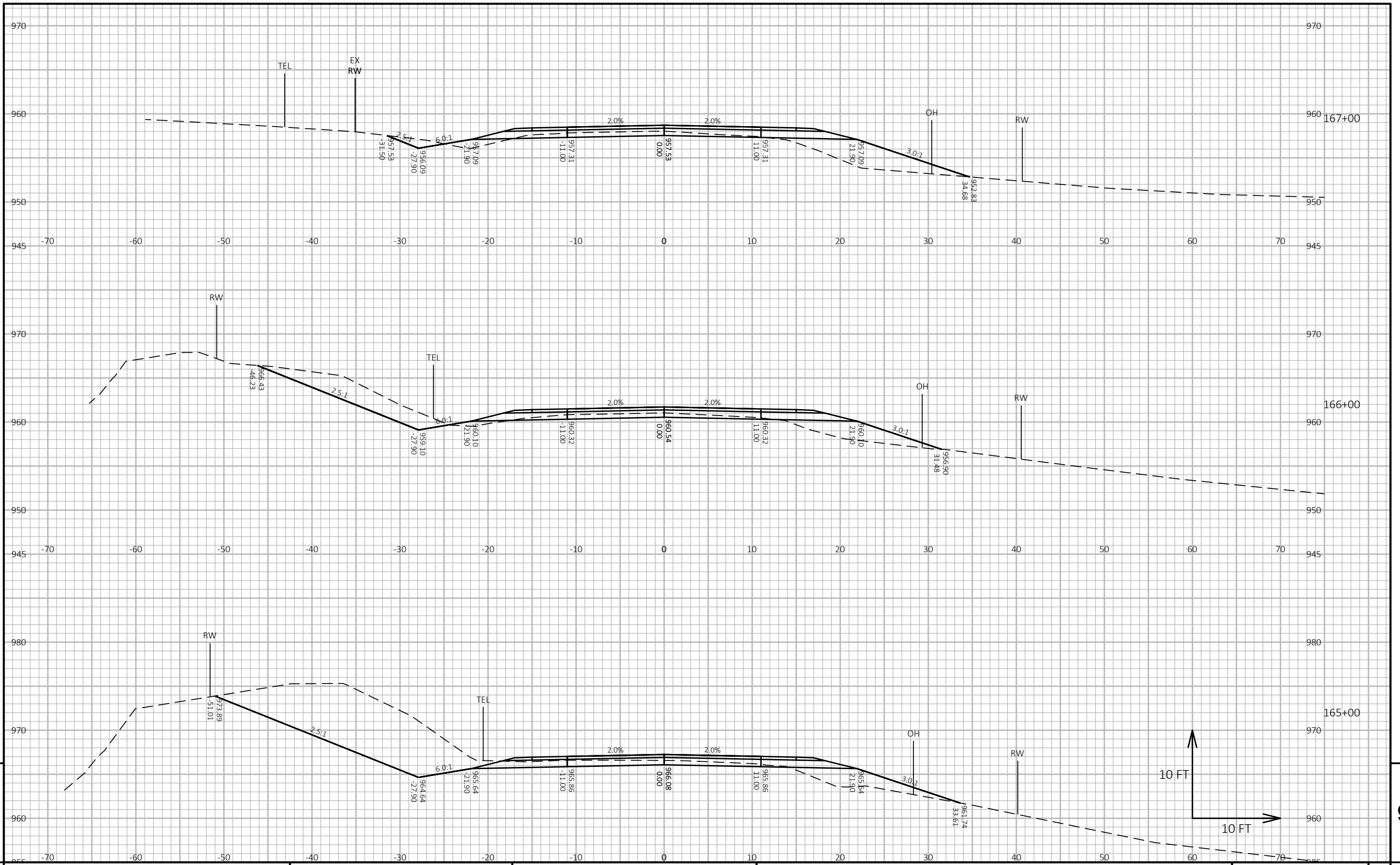

PROJECT NO: 7880-07-73 HWY: CTH H COUNTY: DUNN CROSS SECTIONS: CTH H SHEET 9

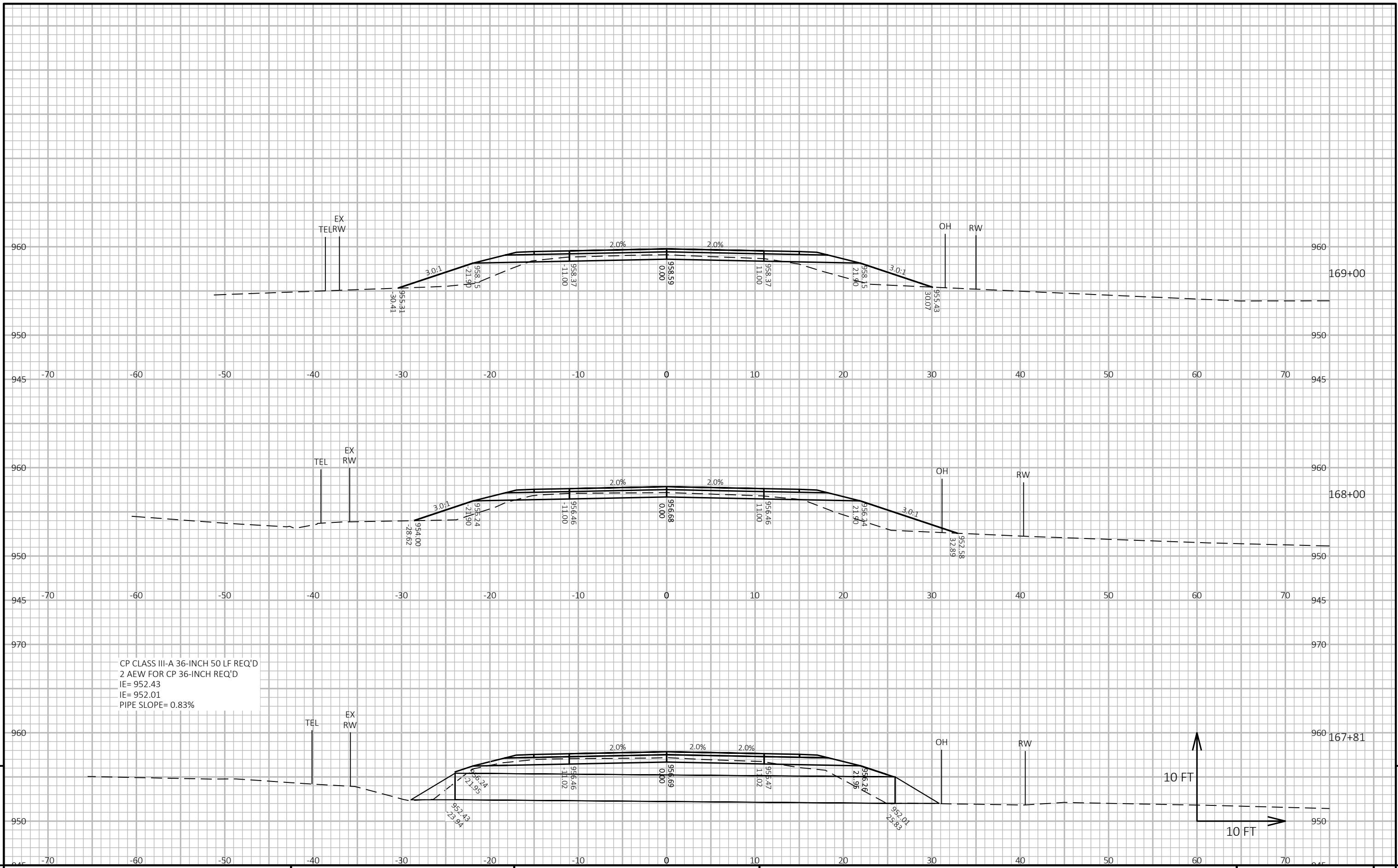

CP CLASS III-A 36-INCH 50 LF REQ'D
 2 AEW FOR CP 36-INCH REQ'D
 IE= 952.43
 IE= 952.01
 PIPE SLOPE= 0.83%

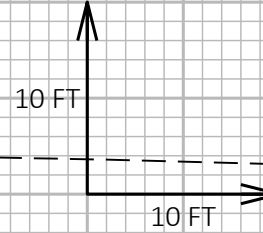

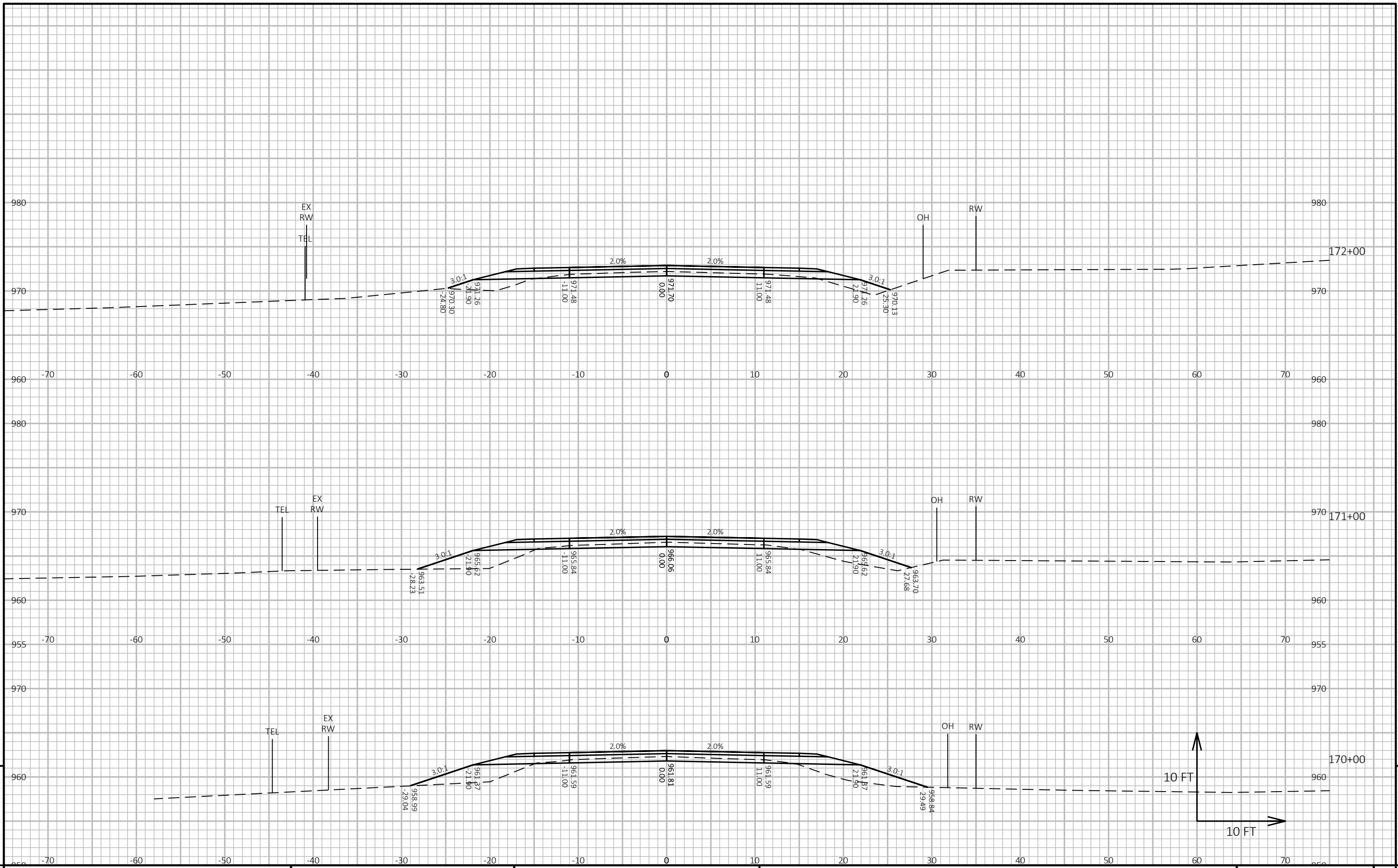

9

9

PROJECT NO: 7880-07-73 HWY: CTH H COUNTY: DUNN CROSS SECTIONS: CTH H SHEET E

FILE NAME : C:\OD\CORRE, INC\PROJECTS - DOCUMENTS\WI - NW REGION\7880-07-03_DUNN CO_CTH H\500_CADD\501_C3D_2018\78800703\SHEETS\PLAN\090201-XS.DWG PLOT DATE : 10/14/2021 2:59 PM PLOT BY : NICHOLAS WATHKE PLOT NAME : PLOT SCALE : 1 IN:10 FT HORZ. / 1 IN:10 FT VERT. WISDOT/CADD SHEET 49

LAYOUT NAME - 31

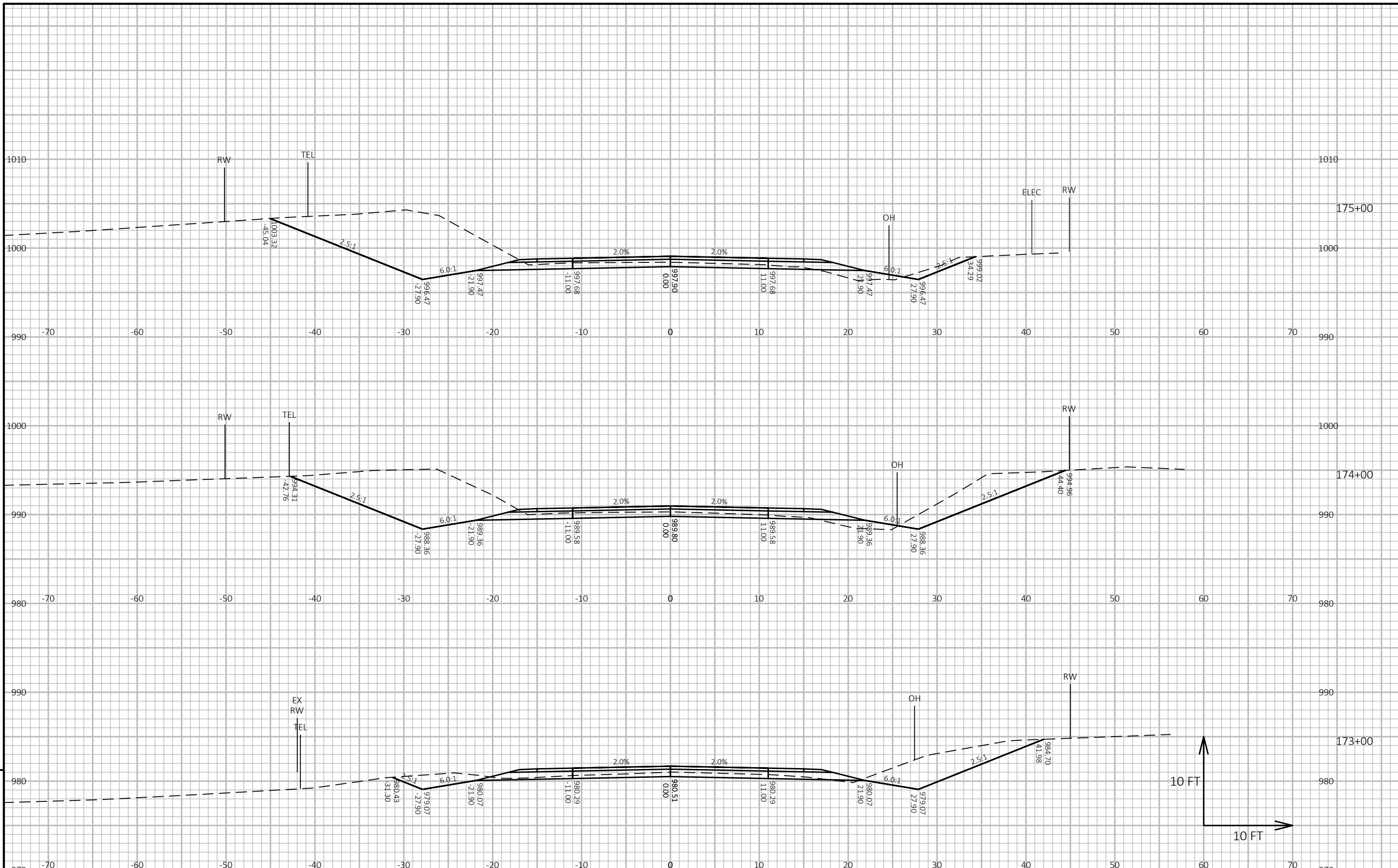

PROJECT NO: 7880-07-73

HWY: CTH H

COUNTY: DUNN

CROSS SECTIONS: CTH H

SHEET

E

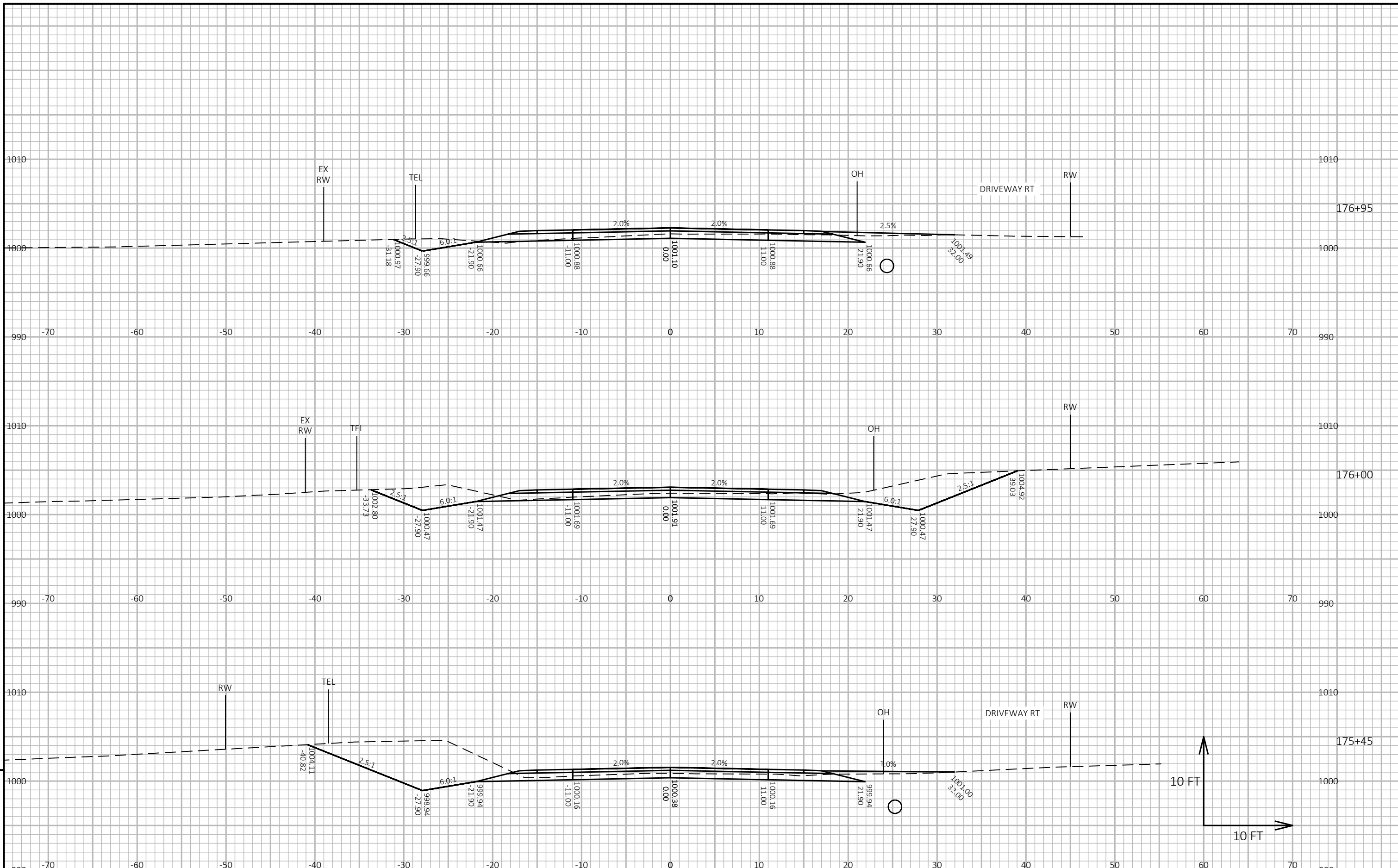

9

9

PROJECT NO: 7880-07-73	HWY: CTH H	COUNTY: DUNN	CROSS SECTIONS: CTH H	SHEET	E
------------------------	------------	--------------	-----------------------	-------	---

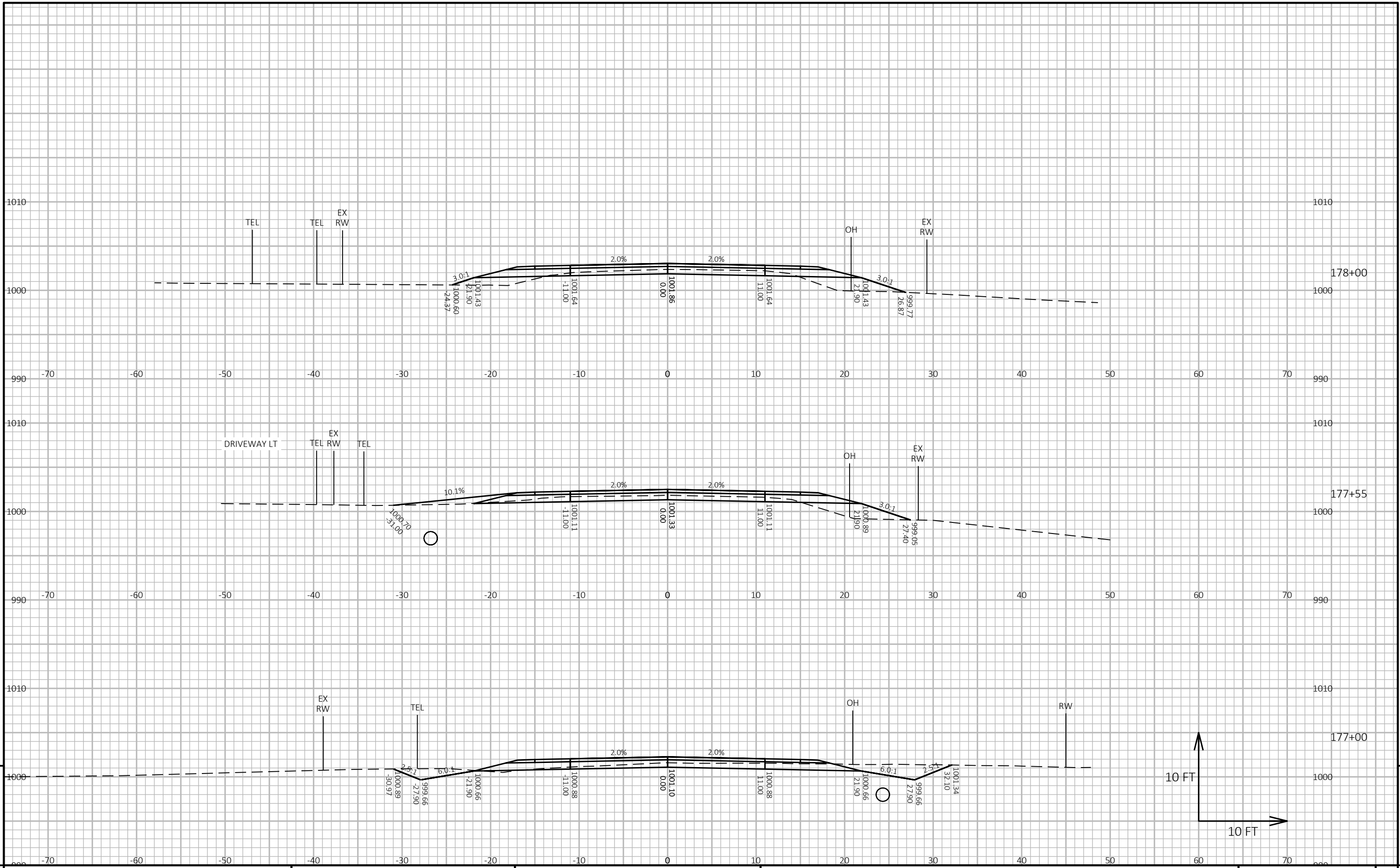

9

9

PROJECT NO: 7880-07-73 HWY: CTH H COUNTY: DUNN CROSS SECTIONS: CTH H SHEET E

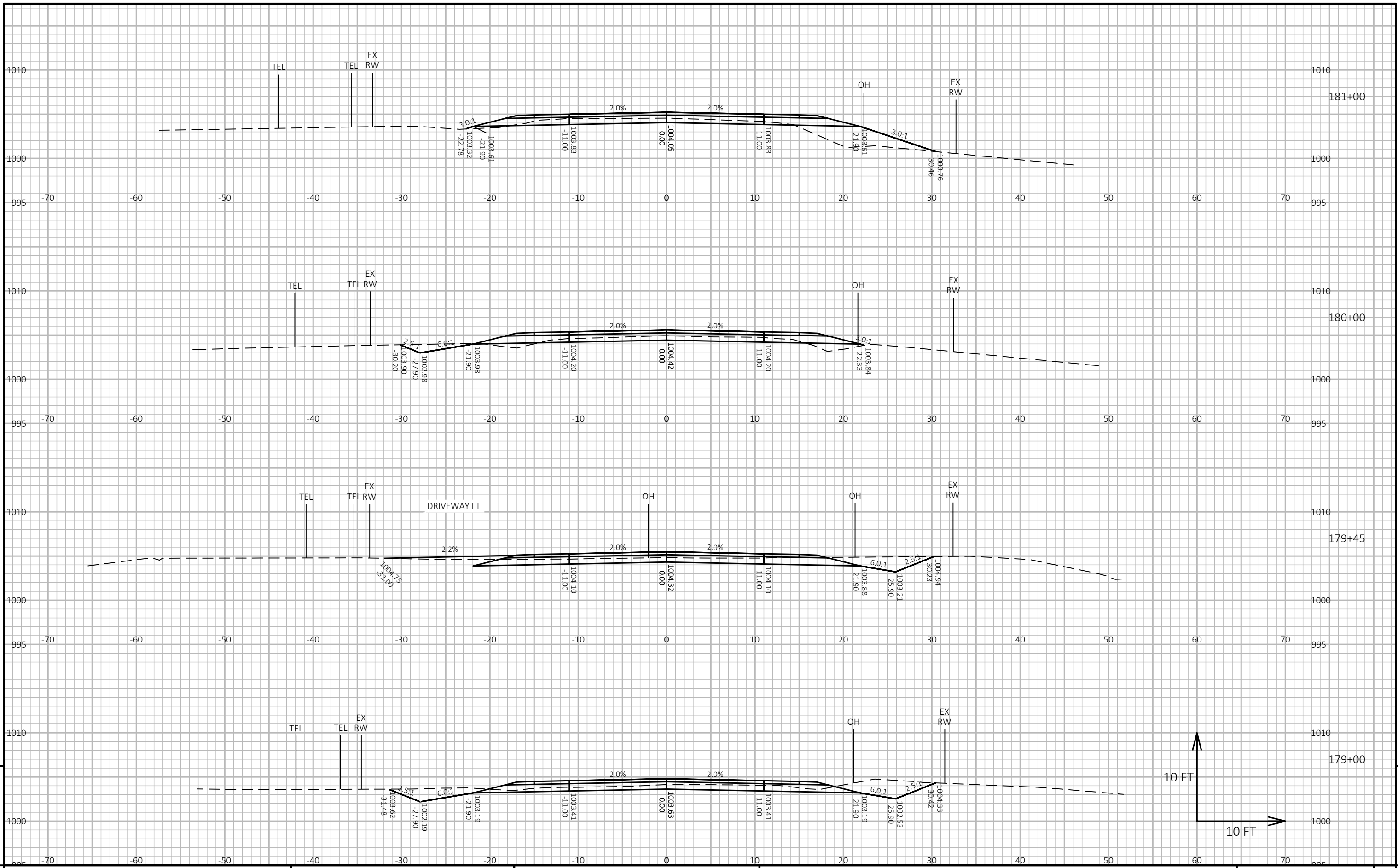

PROJECT NO: 7880-07-73 HWY: CTH H COUNTY: DUNN CROSS SECTIONS: CTH H SHEET E

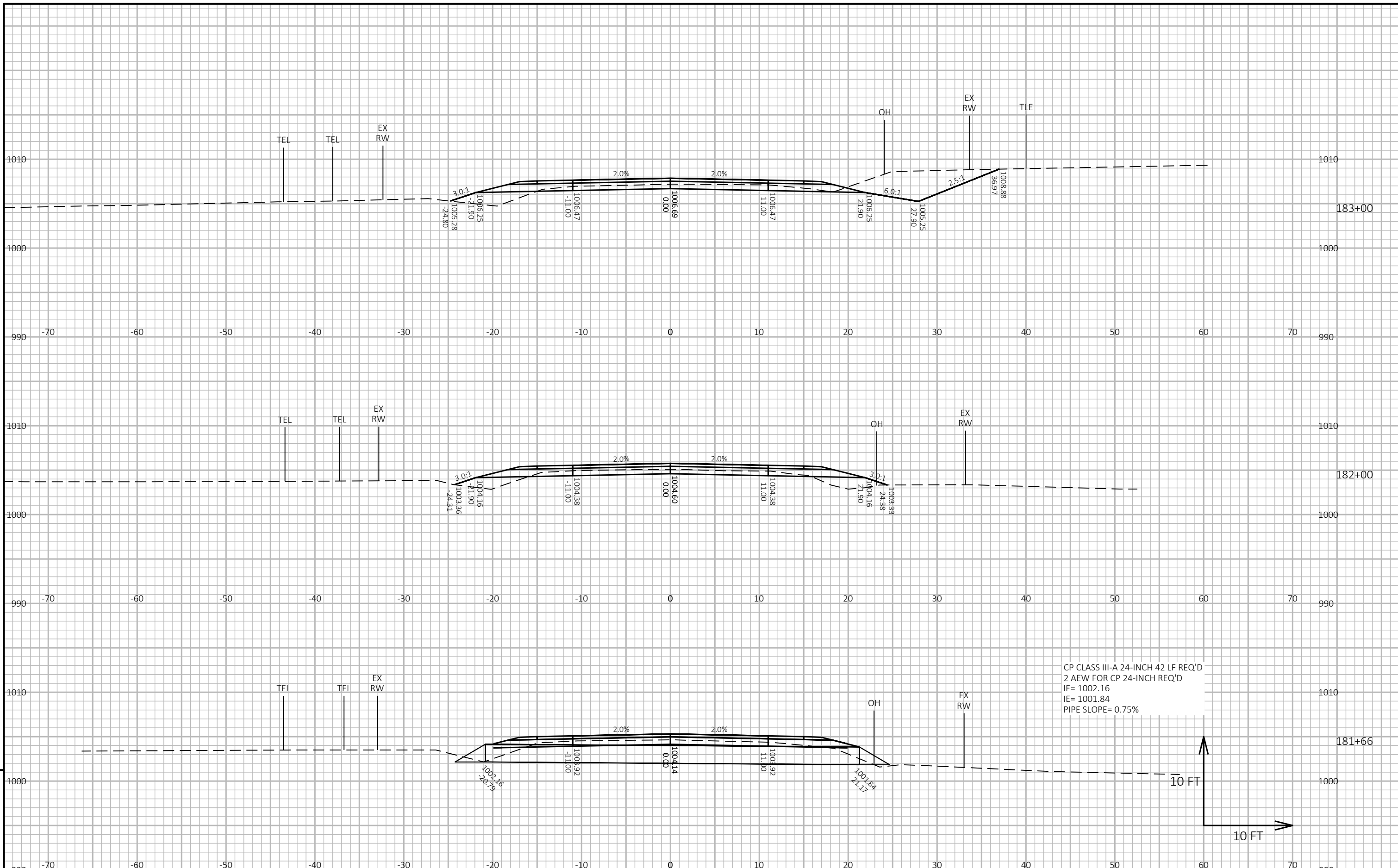

CP CLASS III-A 24-INCH 42 LF REQ'D
 2 AEW FOR CP 24-INCH REQ'D
 IE= 1002.16
 IE= 1001.84
 PIPE SLOPE= 0.75%

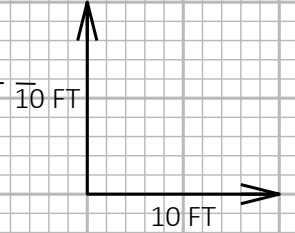

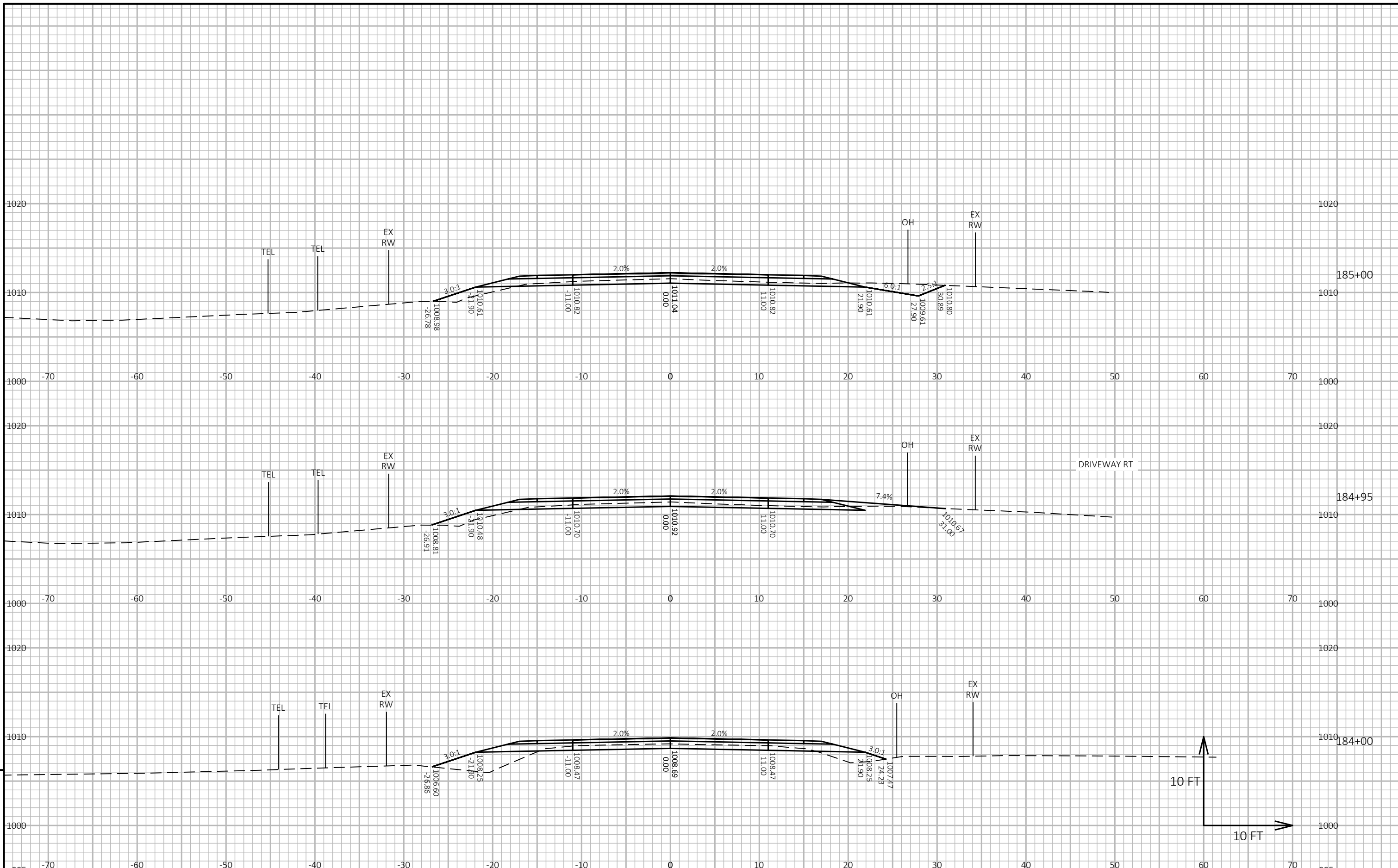

9

9

PROJECT NO: 7880-07-73	HWY: CTH H	COUNTY: DUNN	CROSS SECTIONS: CTH H	SHEET	E
------------------------	------------	--------------	-----------------------	-------	---

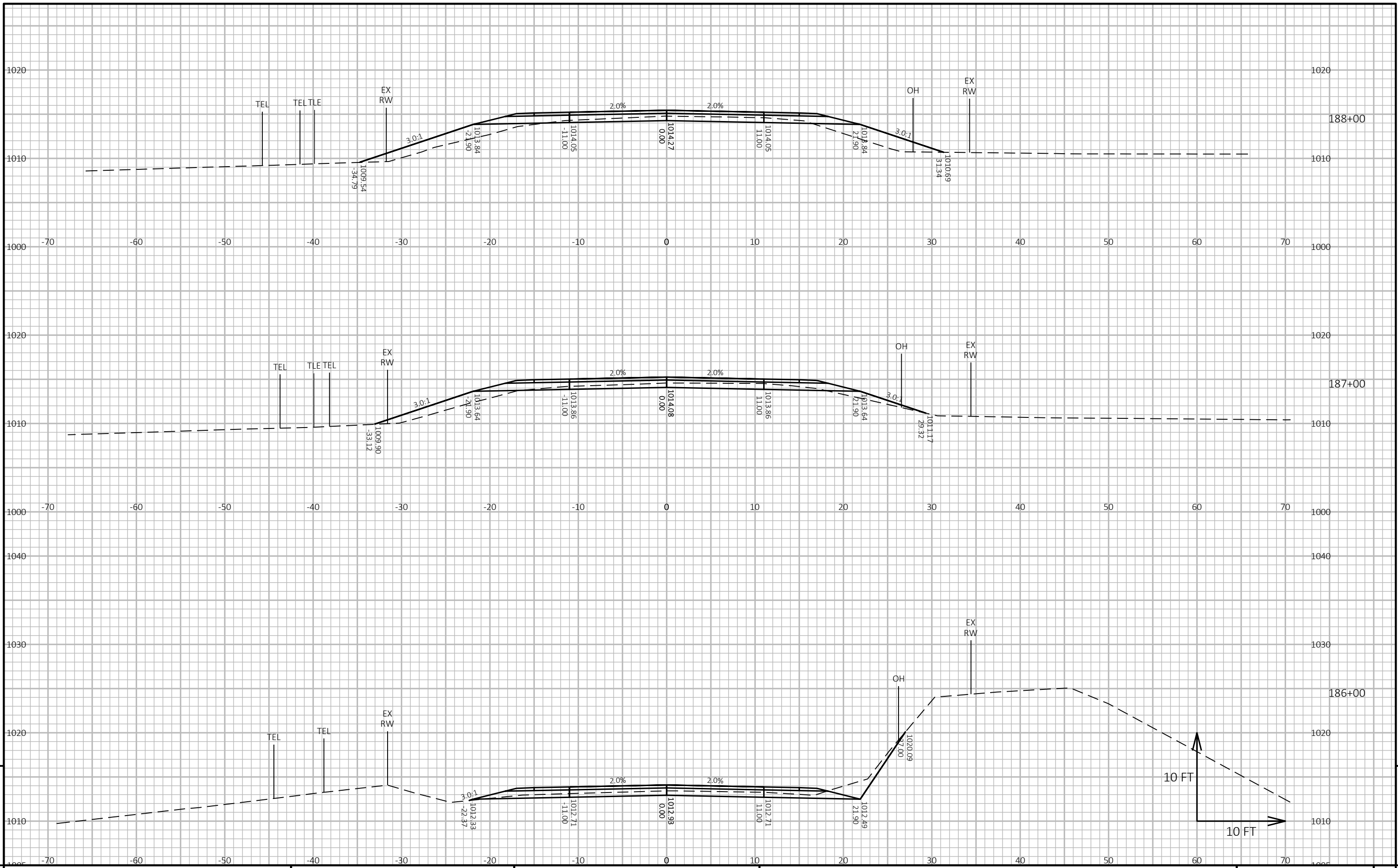

PROJECT NO: 7880-07-73

HWY: CTH H

COUNTY: DUNN

CROSS SECTIONS: CTH H

SHEET

E

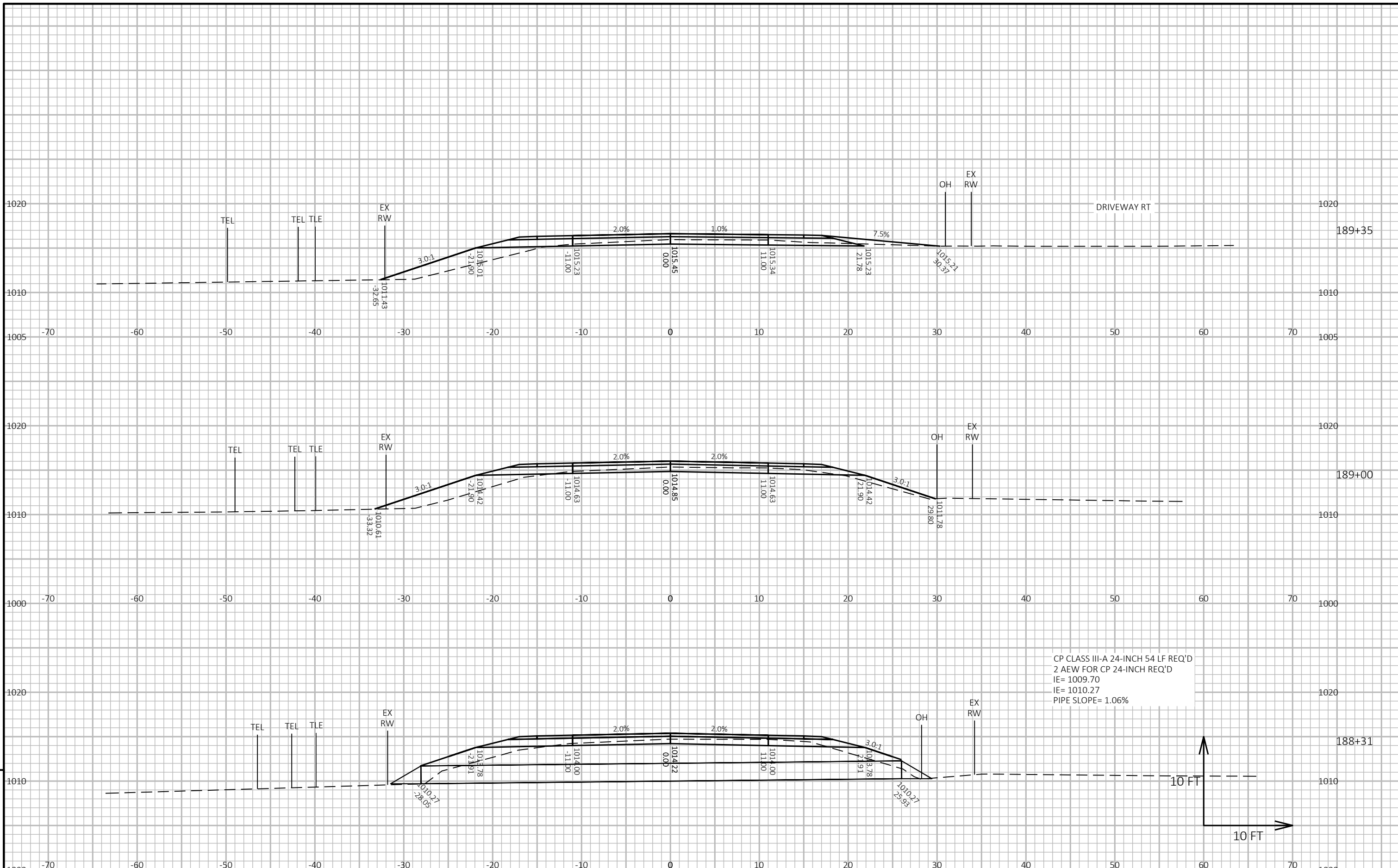

PROJECT NO: 7880-07-73

HWY: CTH H

COUNTY: DUNN

CROSS SECTIONS: CTH H

SHEET

E

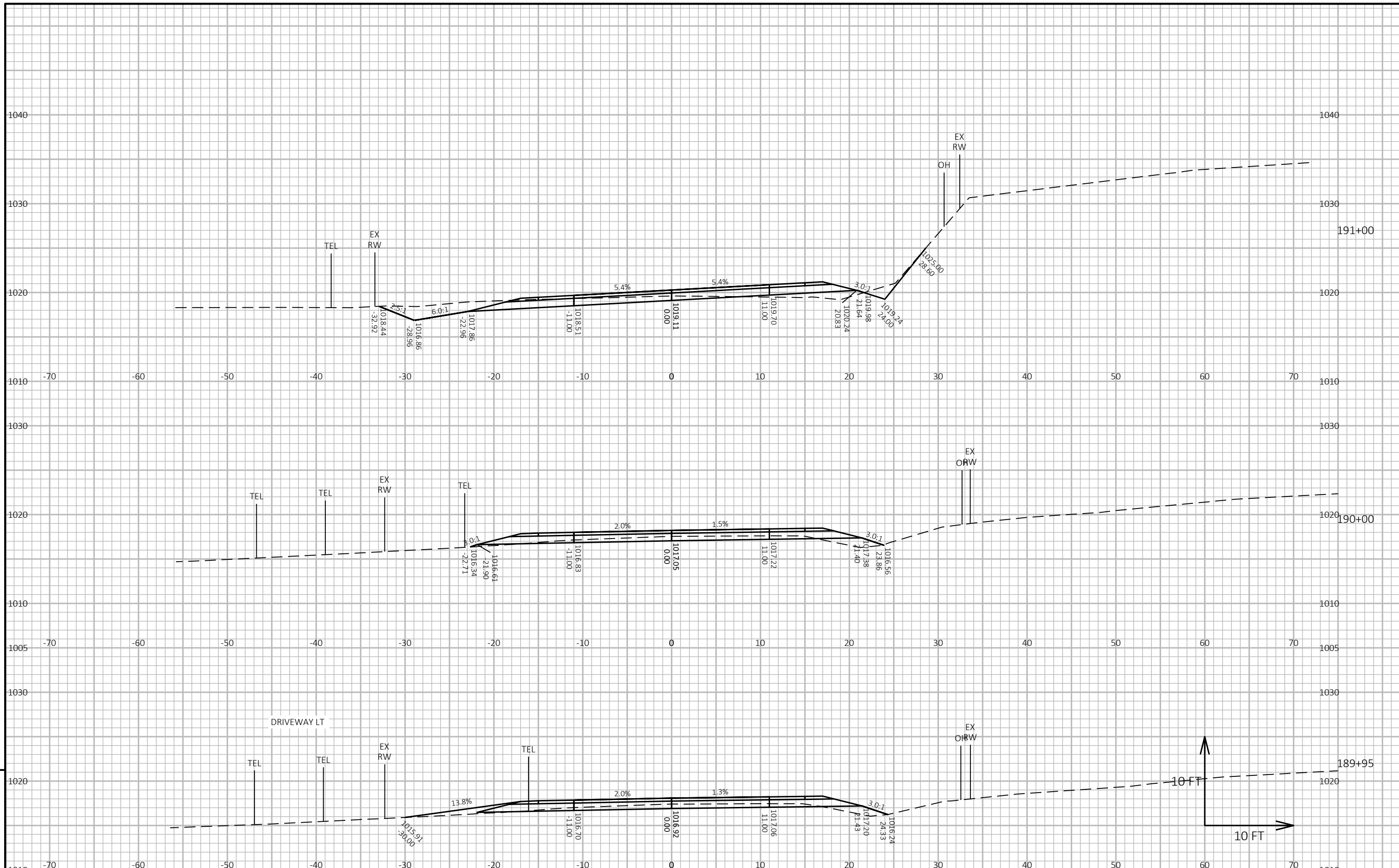

PROJECT NO: 7880-07-73

HWY: CTH H

COUNTY: DUNN

CROSS SECTIONS: CTH H

SHEET

E

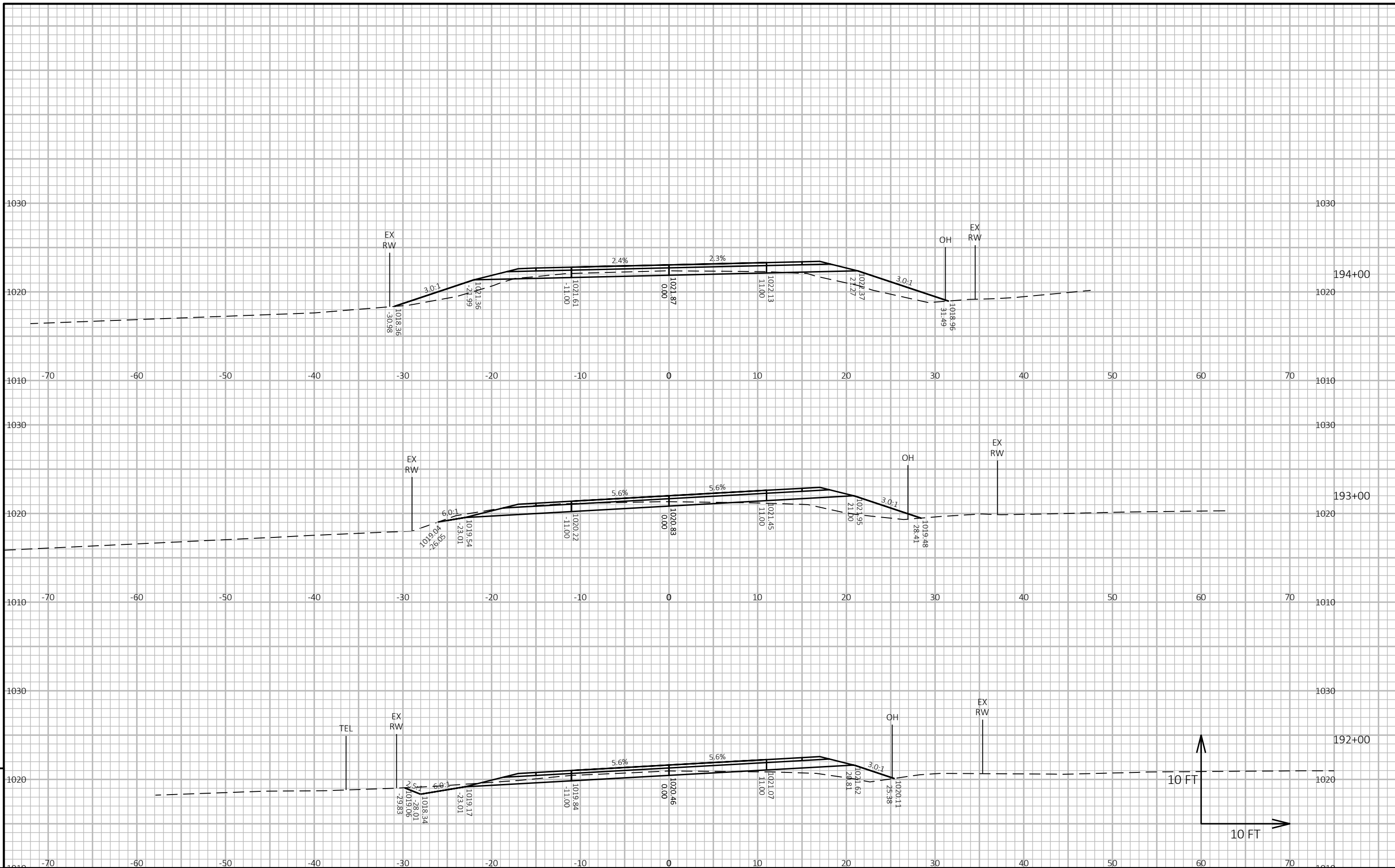

PROJECT NO: 7880-07-73

HWY: CTH H

COUNTY: DUNN

CROSS SECTIONS: CTH H

SHEET

E

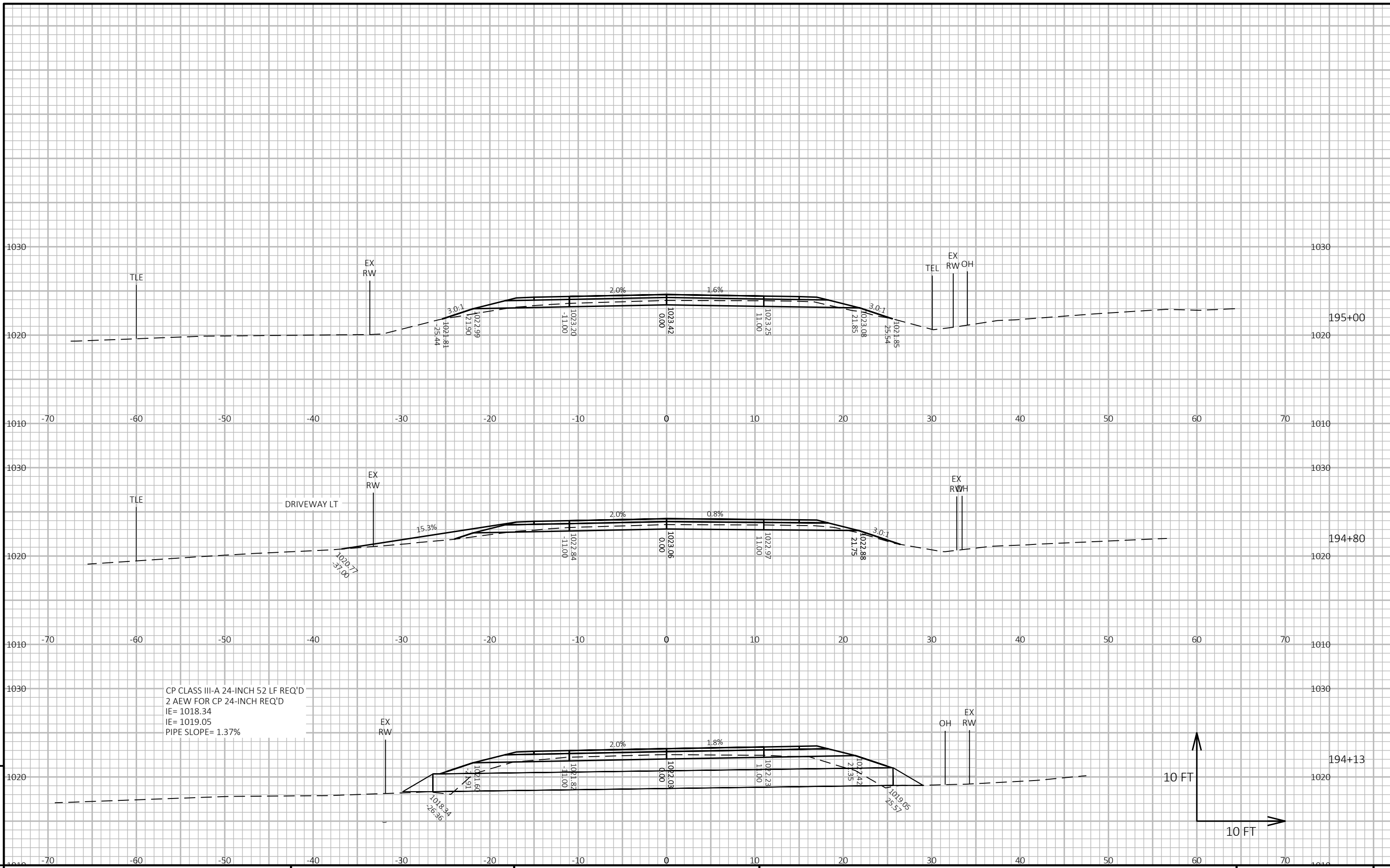

PROJECT NO: 7880-07-73

HWY: CTH H

COUNTY: DUNN

CROSS SECTIONS: CTH H

SHEET

E

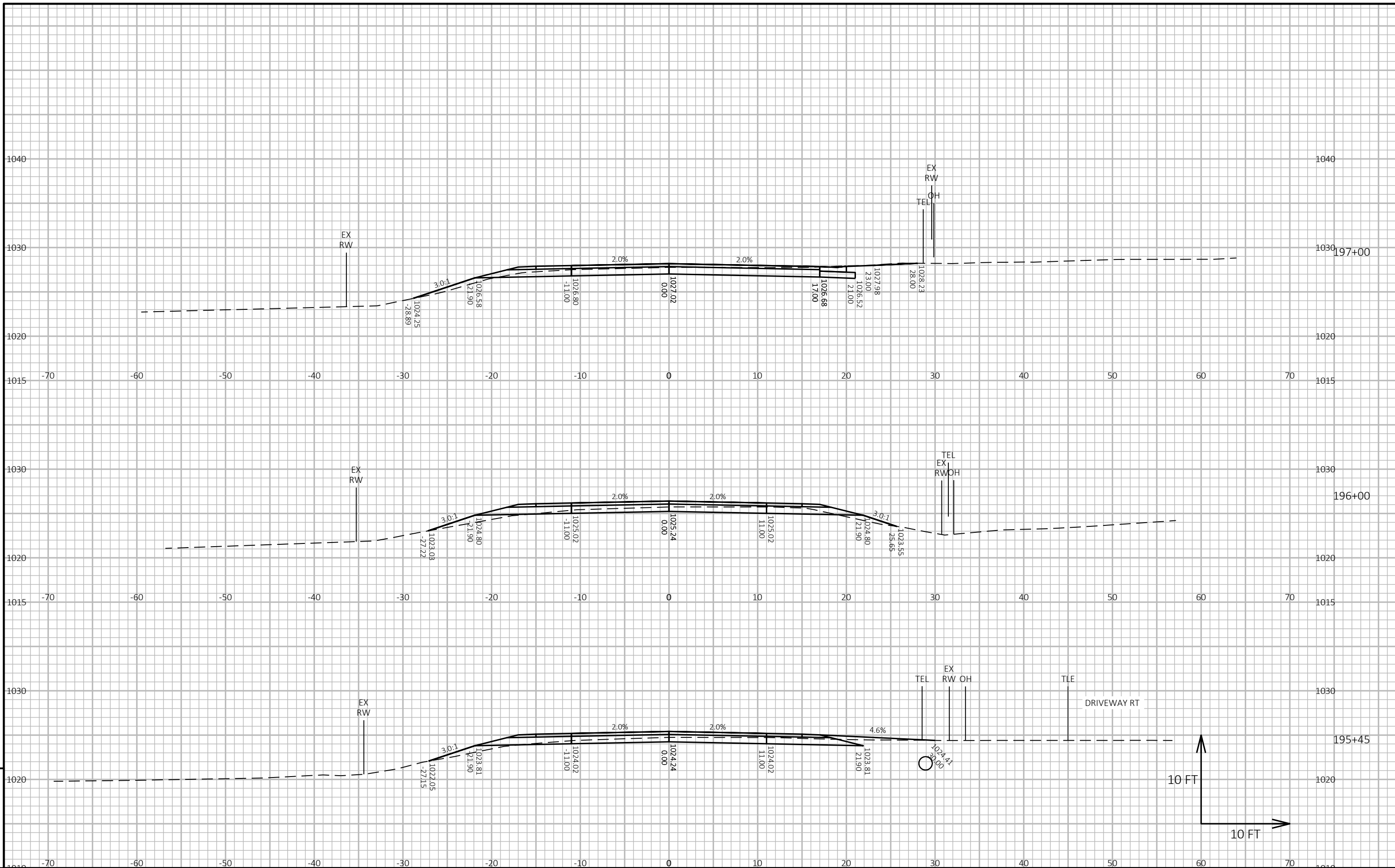

PROJECT NO: 7880-07-73

HWY: CTH H

COUNTY: DUNN

CROSS SECTIONS: CTH H

SHEET

E

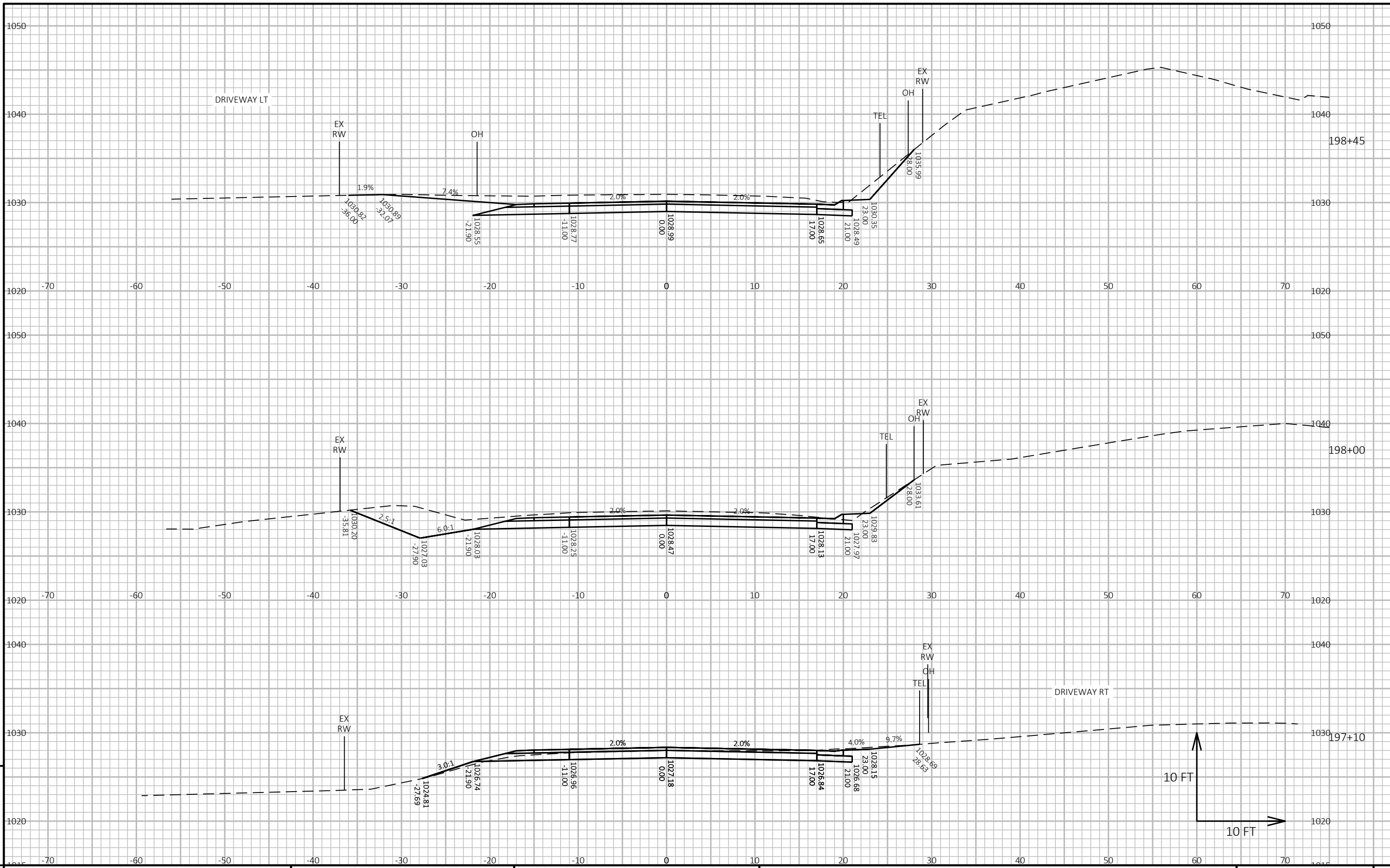

PROJECT NO: 7880-07-73

HWY: CTH H

COUNTY: DUNN

CROSS SECTIONS: CTH H

SHEET

E

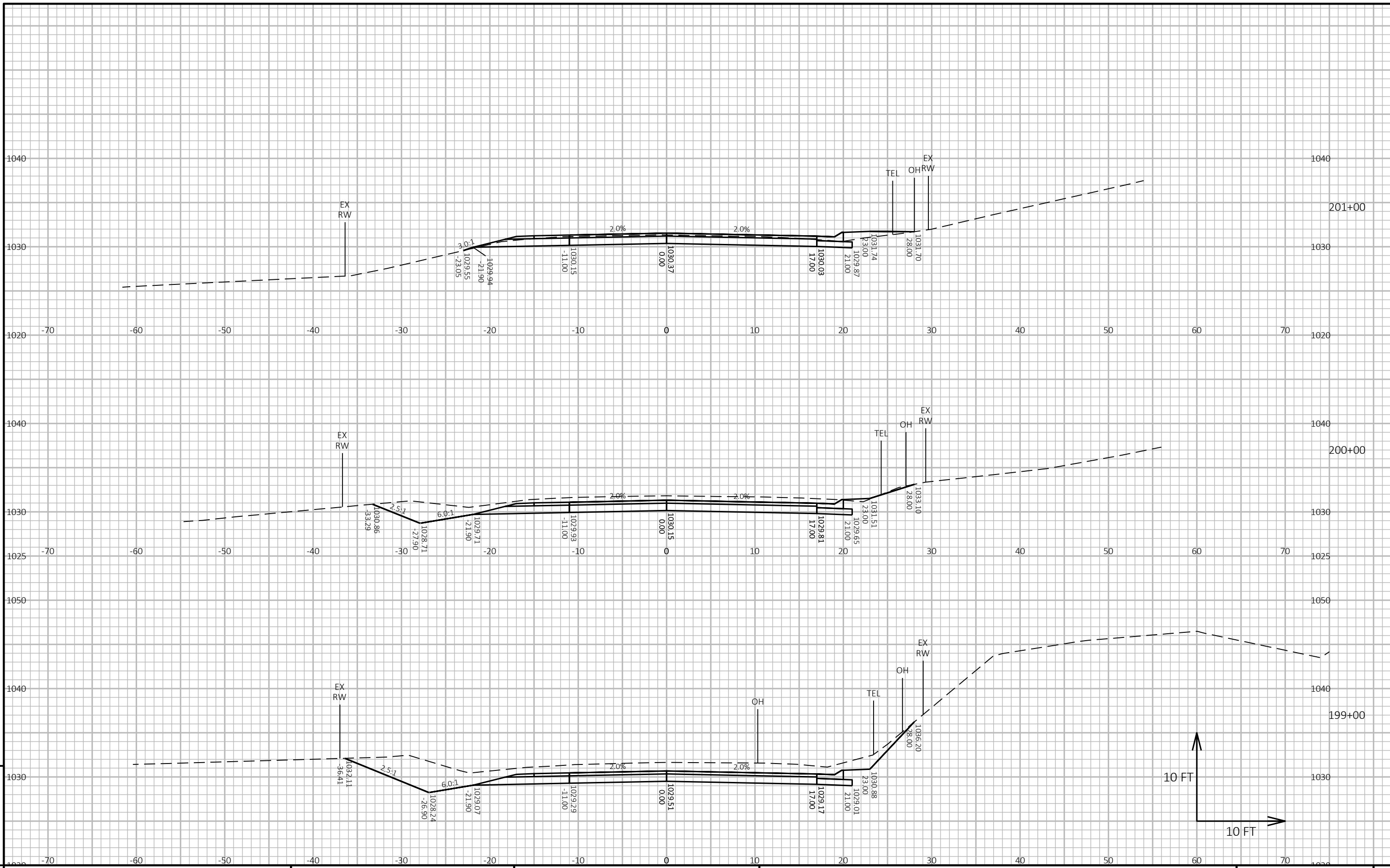

9

9

PROJECT NO: 7880-07-73 HWY: CTH H COUNTY: DUNN CROSS SECTIONS: CTH H SHEET E

FILE NAME: C:\OD\CORRE, INC\PROJECTS - DOCUMENTS\WI - NW REGION\7880-07-03_DUNN CO_CTH H\500_CADD\501_C3D_2018\78800703\SHEETS\PLAN\090201-XS.DWG PLOT DATE: 10/14/2021 3:03 PM PLOT BY: NICHOLAS WATKHE PLOT NAME: PLOT SCALE: 1 IN:10 FT HORZ. / 1 IN:10 FT VERT. WISDOT/CADD SHEET 49

LAYOUT NAME - 45

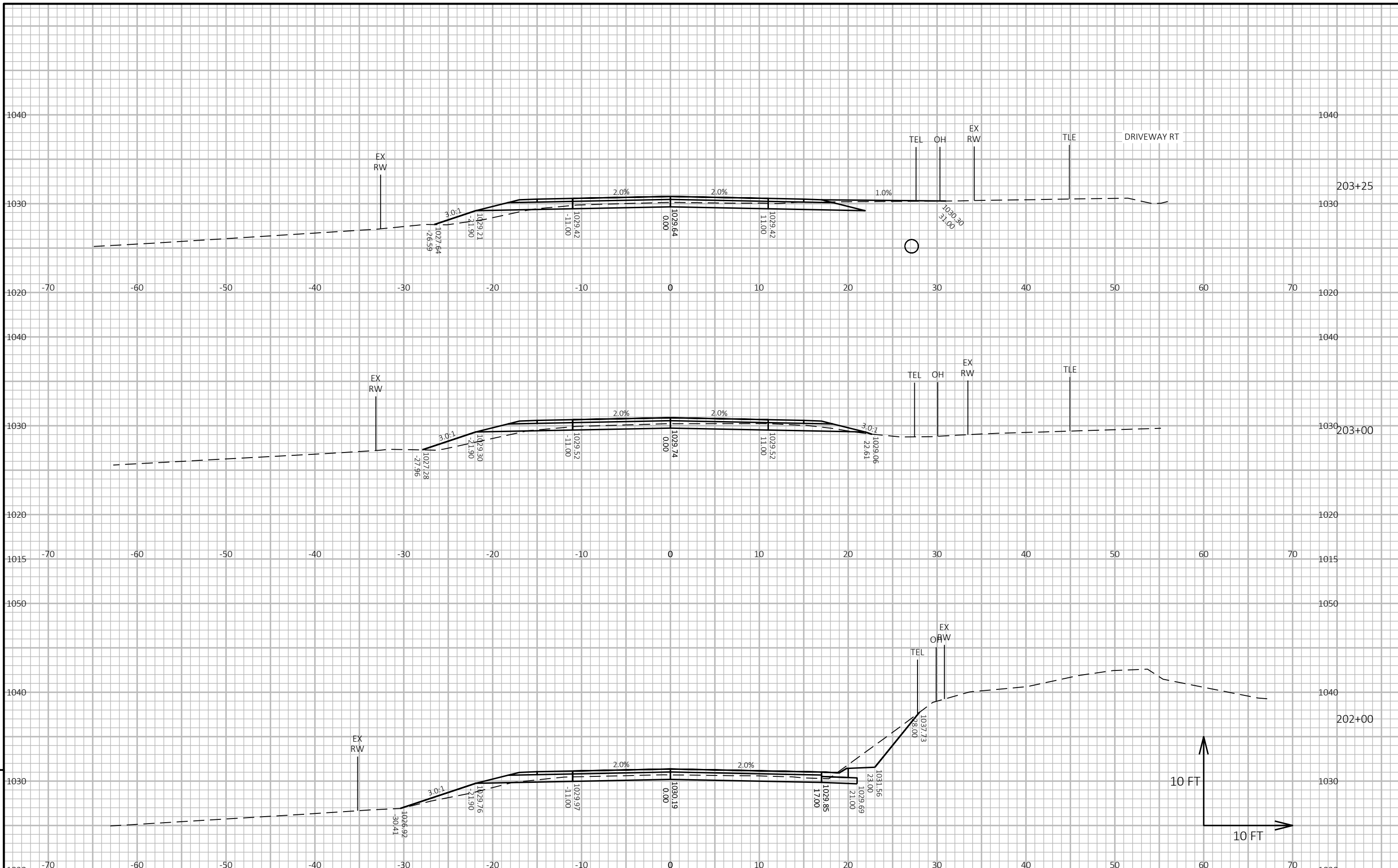

PROJECT NO: 7880-07-73

HWY: CTH H

COUNTY: DUNN

CROSS SECTIONS: CTH H

SHEET

E

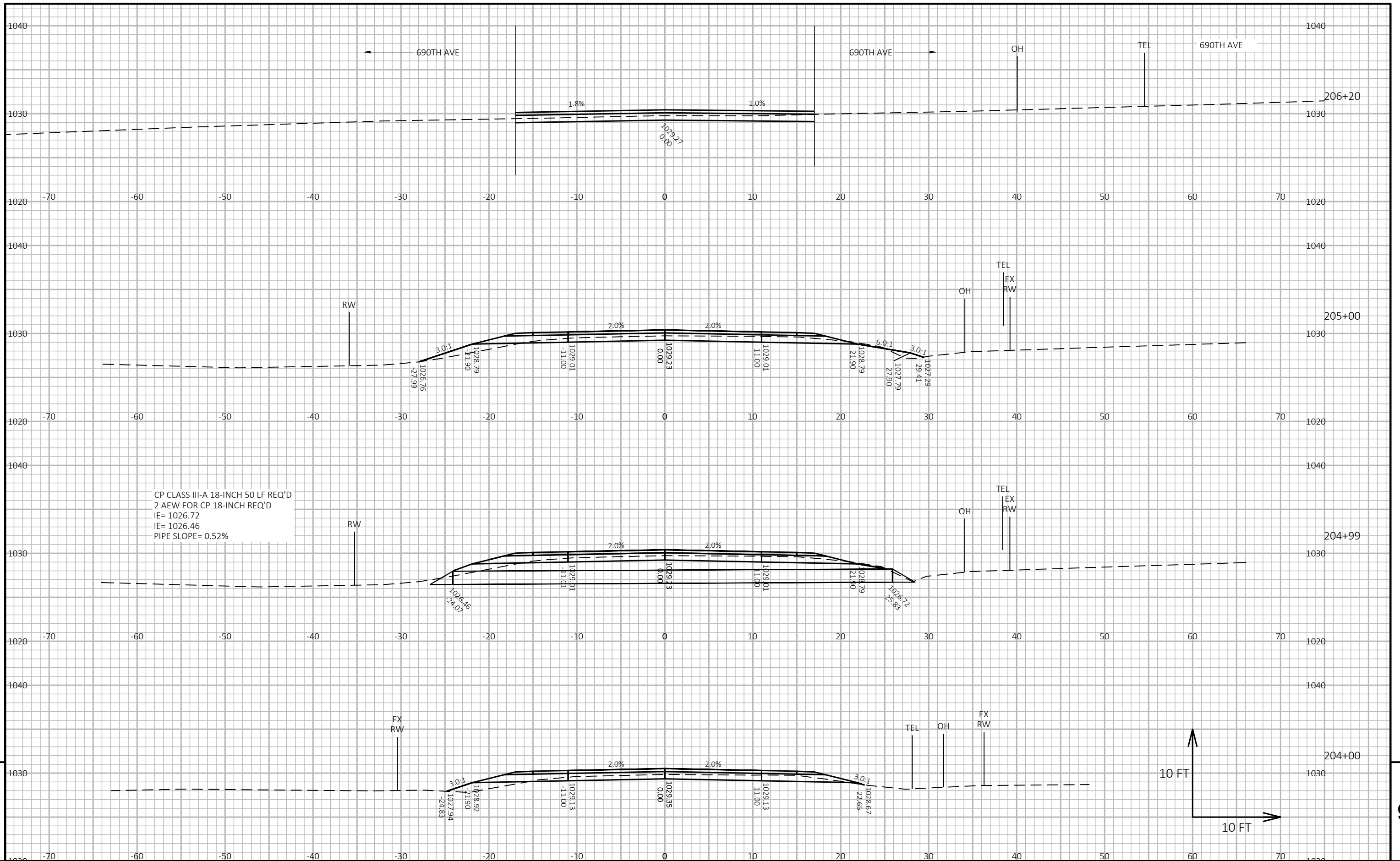

PROJECT NO: 7880-07-73

HWY: CTH H

COUNTY: DUNN

CROSS SECTIONS: CTH H

SHEET

E

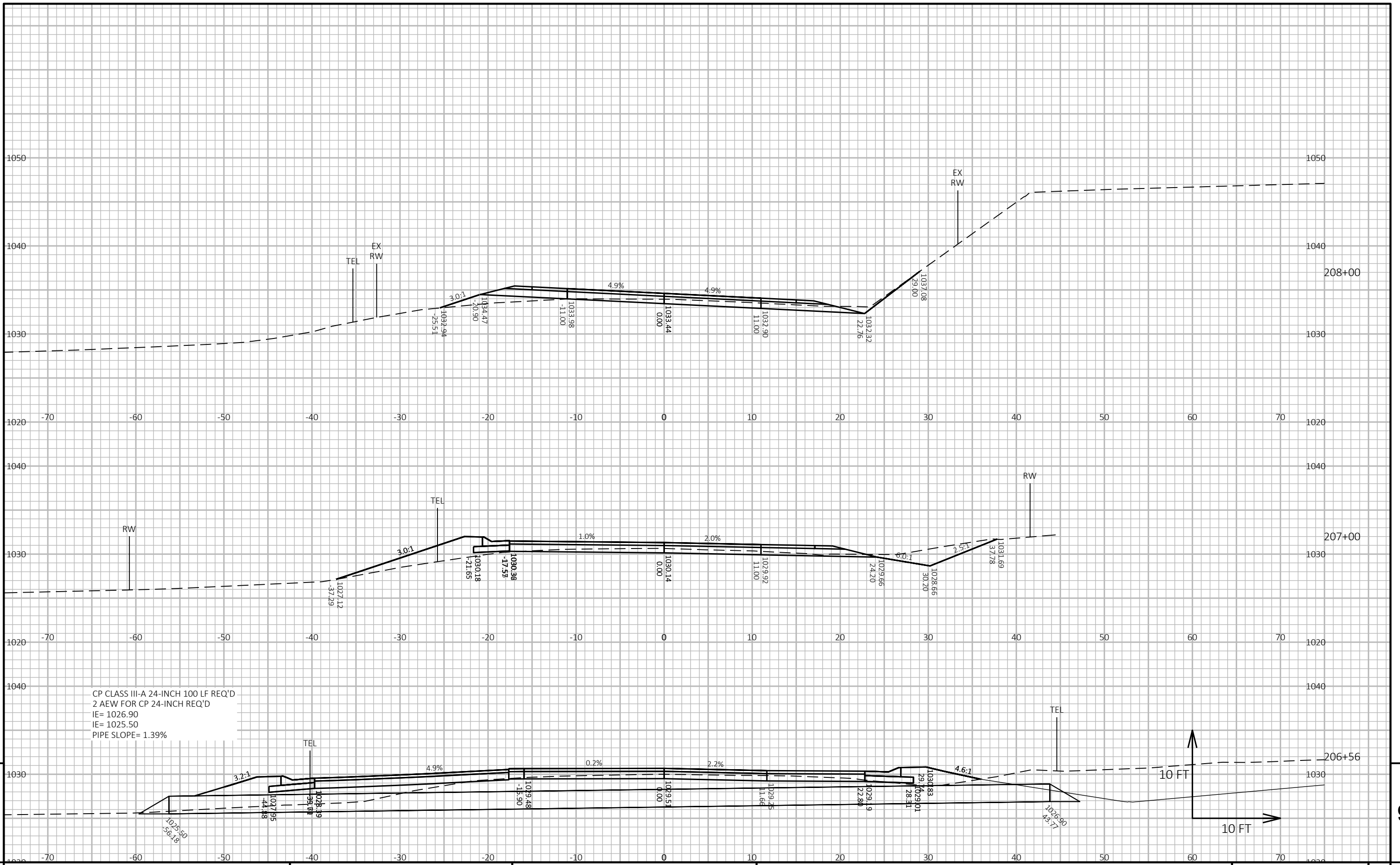

CP CLASS III-A 24-INCH 100 LF REQ'D
 2 AEW FOR CP 24-INCH REQ'D
 IE= 1026.90
 IE= 1025.50
 PIPE SLOPE= 1.39%

PROJECT NO: 7880-07-73 HWY: CTH H COUNTY: DUNN CROSS SECTIONS: CTH H SHEET E

FILE NAME : C:\OD\CORRE, INC\PROJECTS - DOCUMENTS\WI - NW REGION\7880-07-03_DUNN CO_CTH H\500_CADD\501_C3D_2018\78800703\SHEETS\PLAN\090201-XS.DWG PLOT DATE : 10/14/2021 3:03 PM PLOT BY : NICHOLAS WATHKE PLOT NAME : PLOT SCALE : 1 IN:10 FT HORZ. / 1 IN:10 FT VERT. WISDOT/CADD SHEET 49

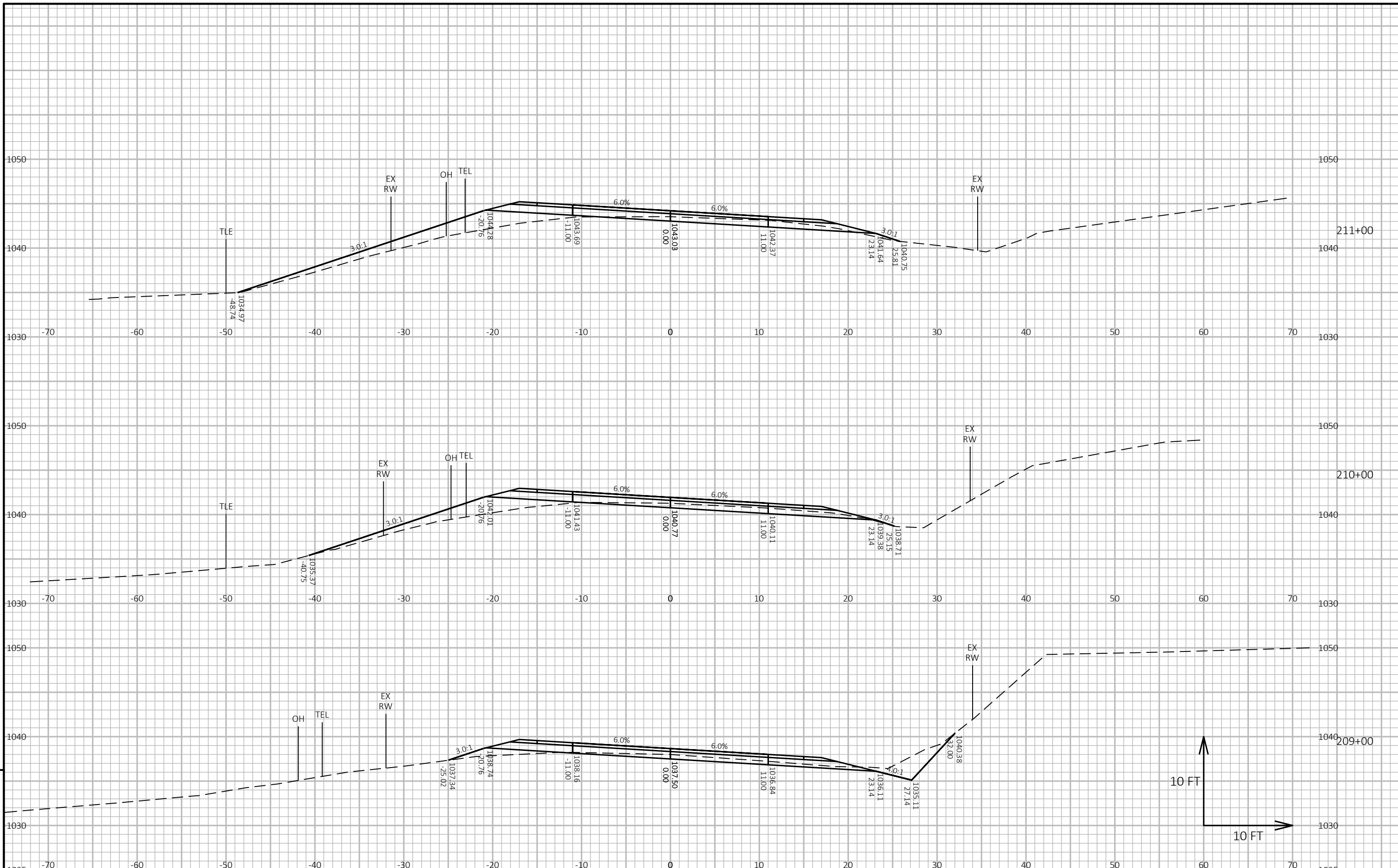

PROJECT NO: 7880-07-73

HWY: CTH H

COUNTY: DUNN

CROSS SECTIONS: CTH H

SHEET

E

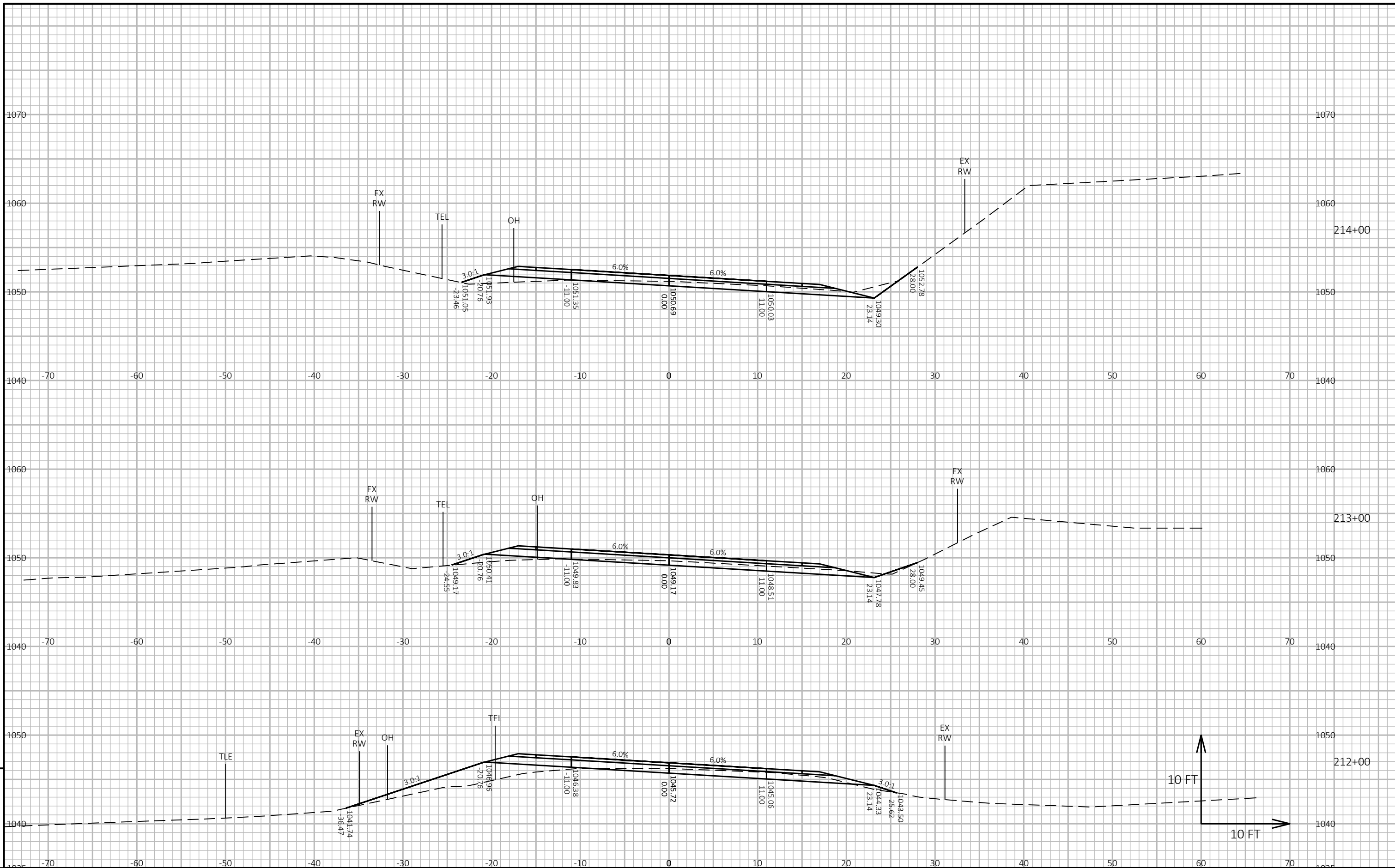

PROJECT NO: 7880-07-73

HWY: CTH H

COUNTY: DUNN

CROSS SECTIONS: CTH H

SHEET

E

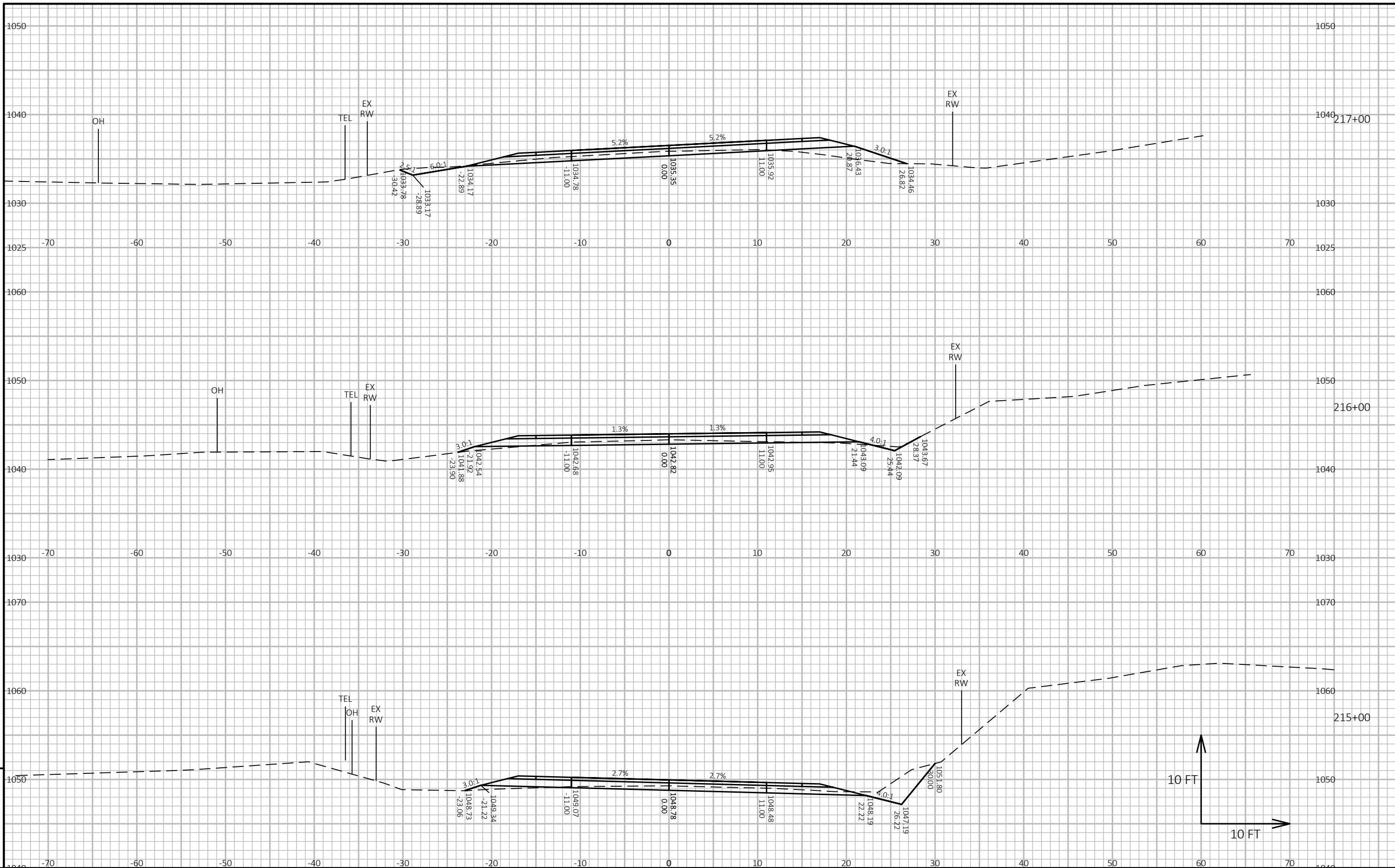

PROJECT NO: 7880-07-73

HWY: CTH H

COUNTY: DUNN

CROSS SECTIONS: CTH H

SHEET

E

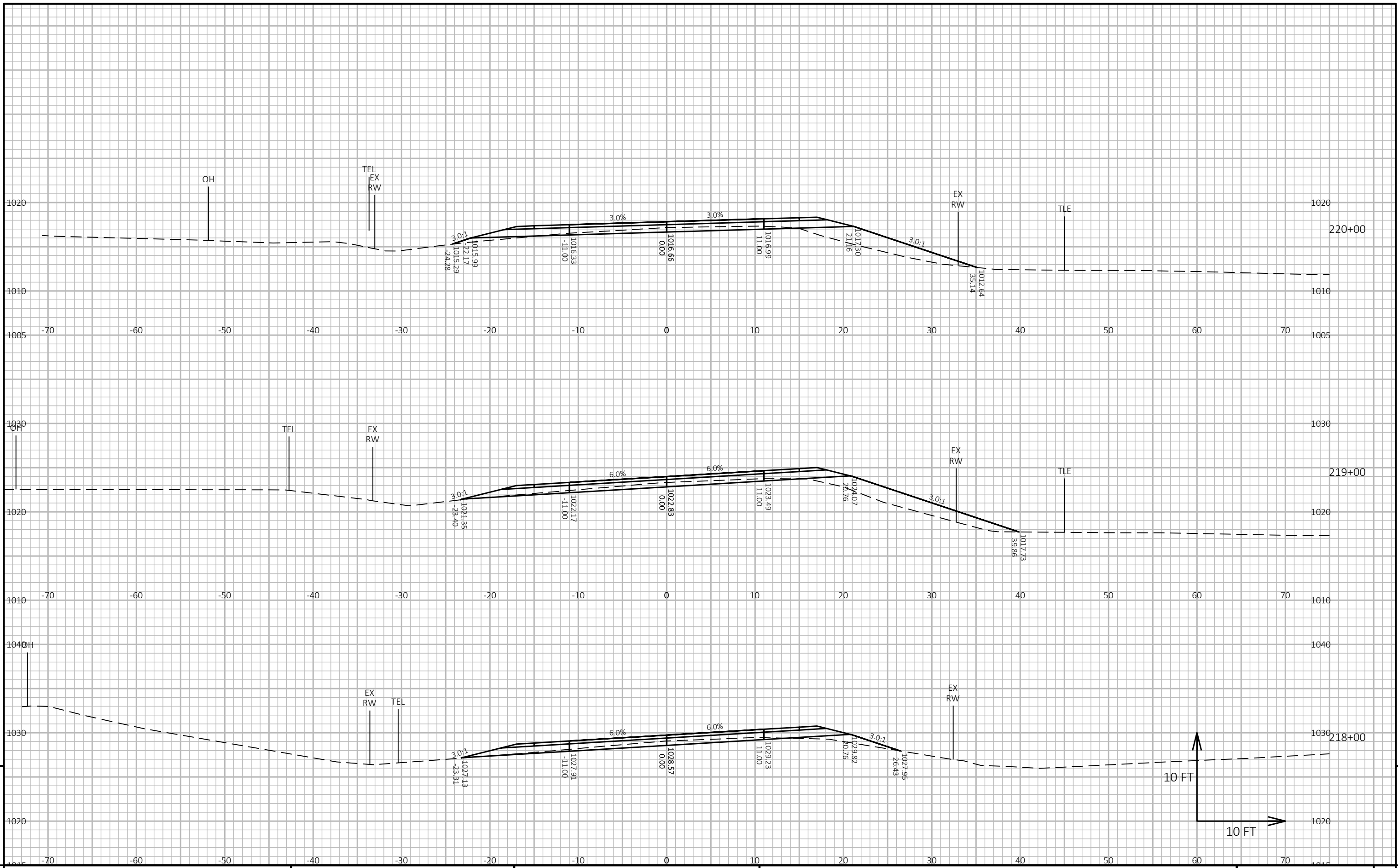

9

9

PROJECT NO: 7880-07-73	HWY: CTH H	COUNTY: DUNN	CROSS SECTIONS: CTH H	SHEET	E
------------------------	------------	--------------	-----------------------	-------	---

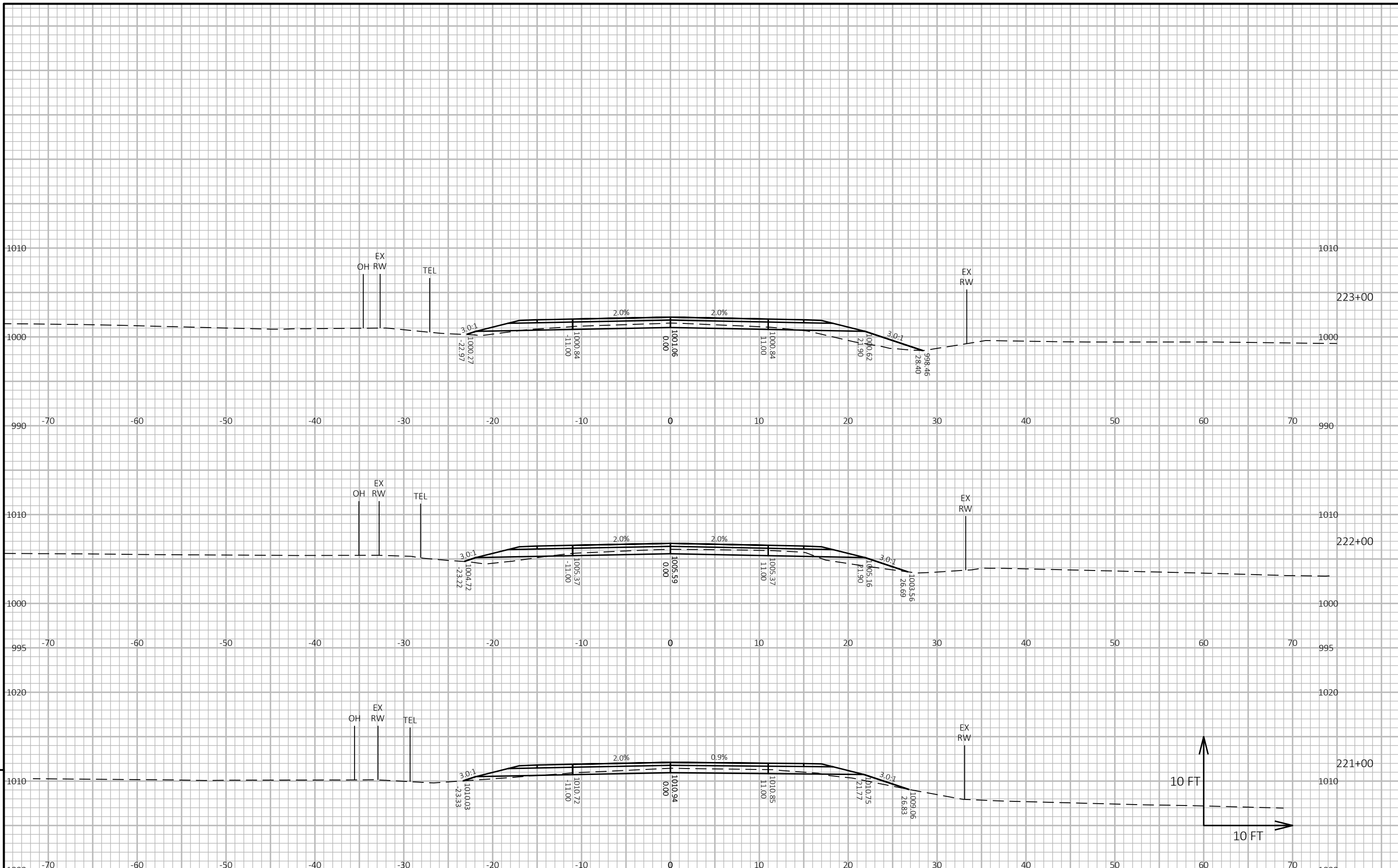

PROJECT NO: 7880-07-73 HWY: CTH H COUNTY: DUNN CROSS SECTIONS: CTH H SHEET E

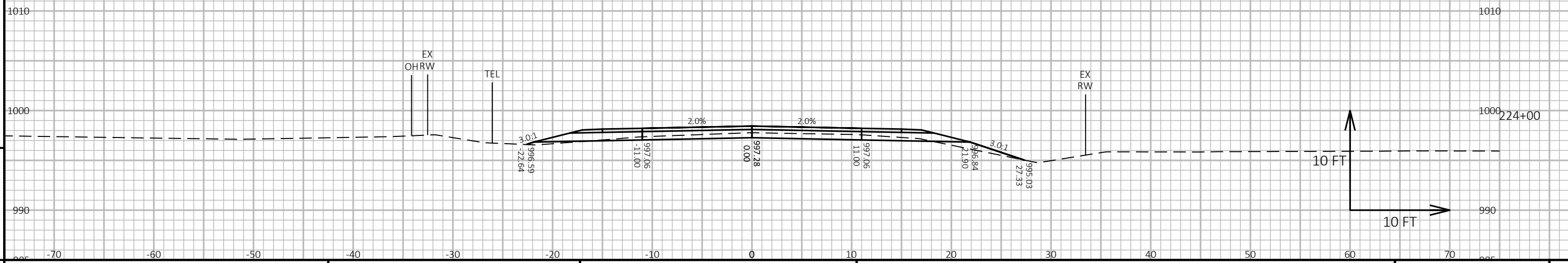
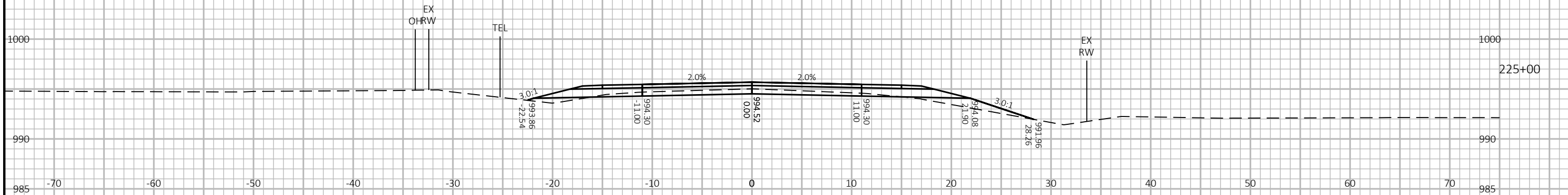
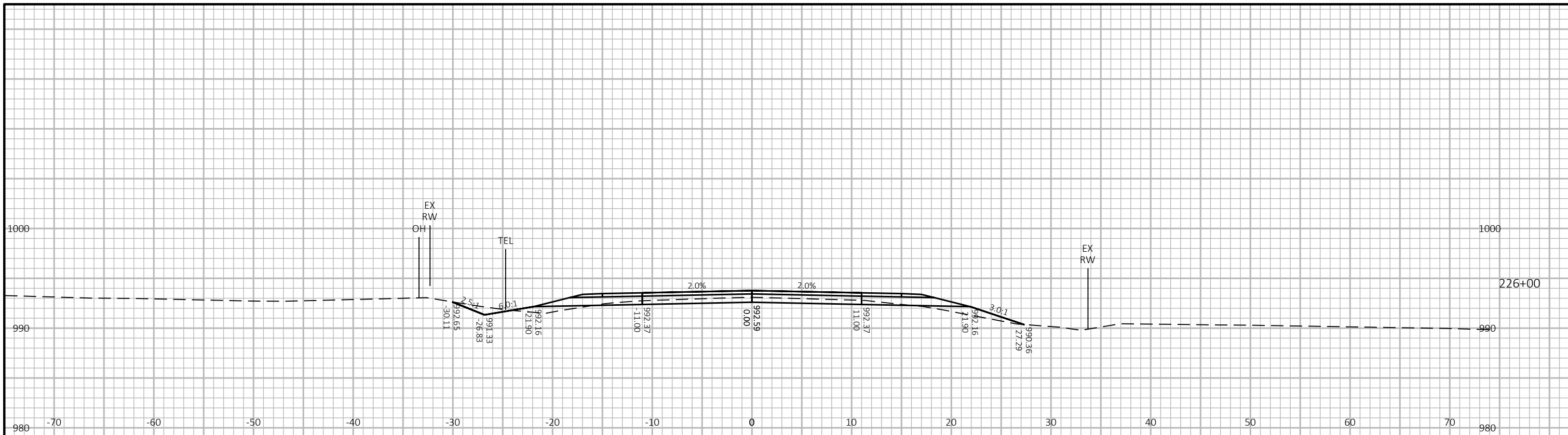

PROJECT NO: 7880-07-73 HWY: CTH H COUNTY: DUNN CROSS SECTIONS: CTH H SHEET 9

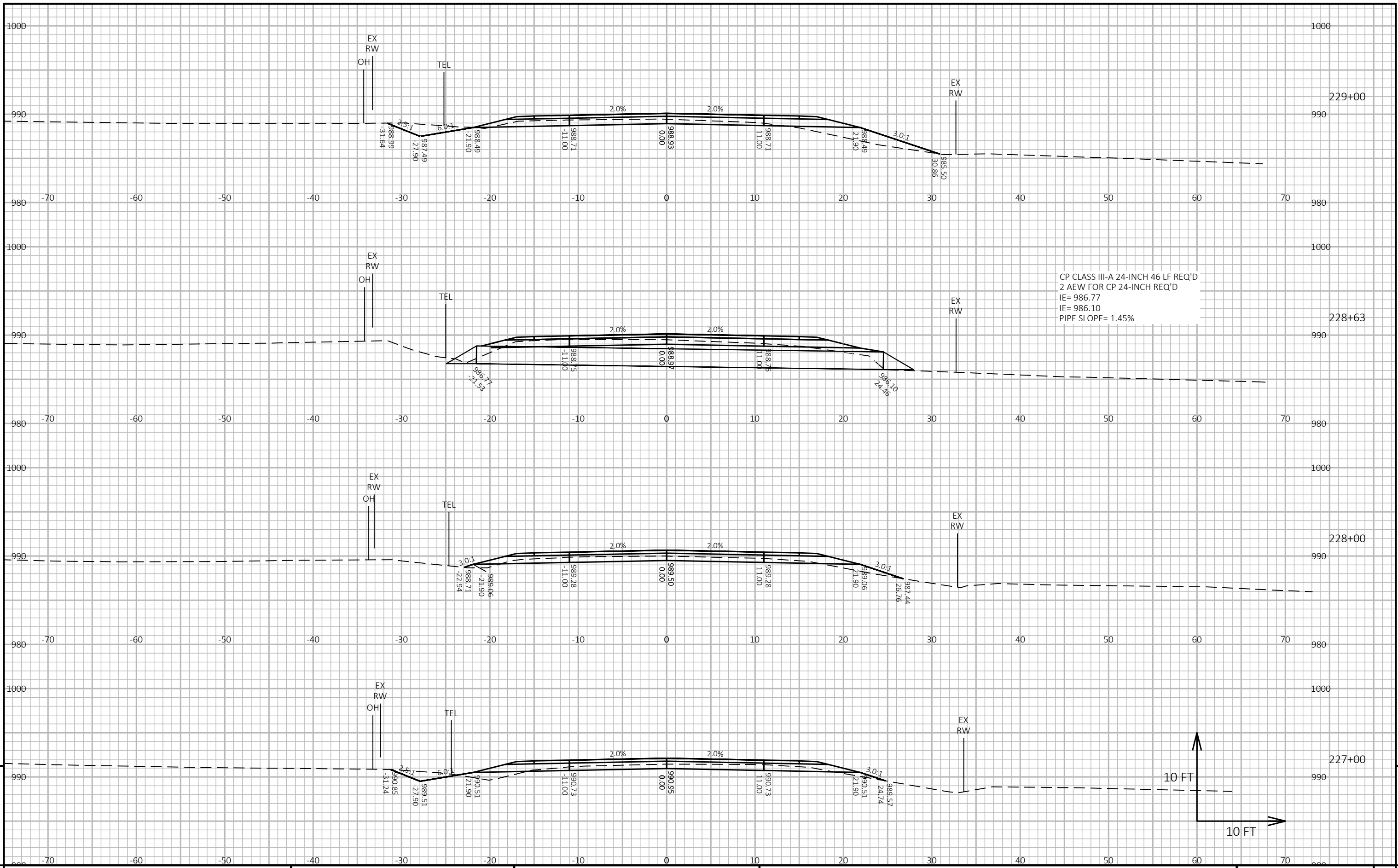

PROJECT NO: 7880-07-73

HWY: CTH H

COUNTY: DUNN

CROSS SECTIONS: CTH H

SHEET

E

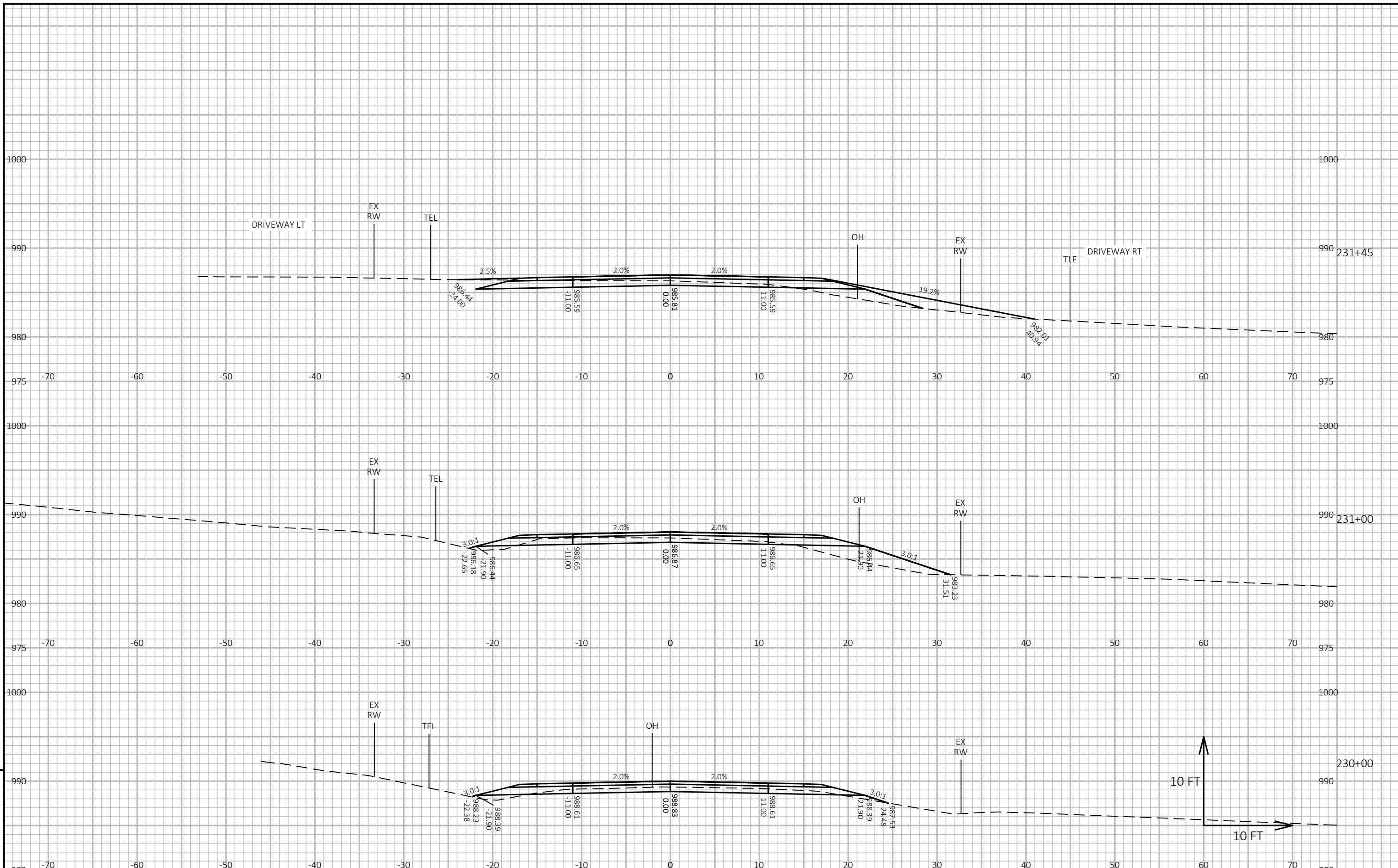

PROJECT NO: 7880-07-73

HWY: CTH H

COUNTY: DUNN

CROSS SECTIONS: CTH H

SHEET

E

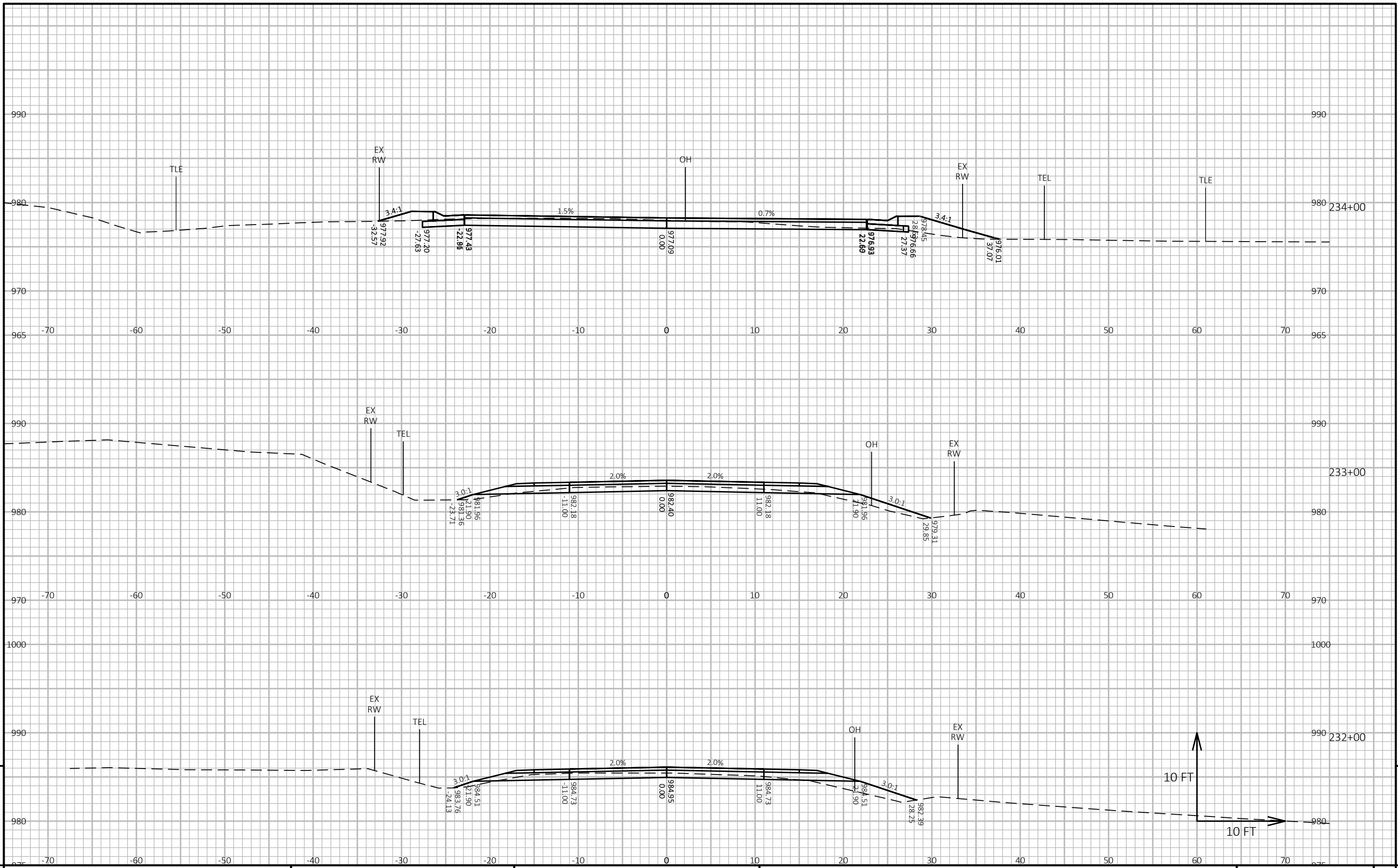

PROJECT NO: 7880-07-73

HWY: CTH H

COUNTY: DUNN

CROSS SECTIONS: CTH H

SHEET

E

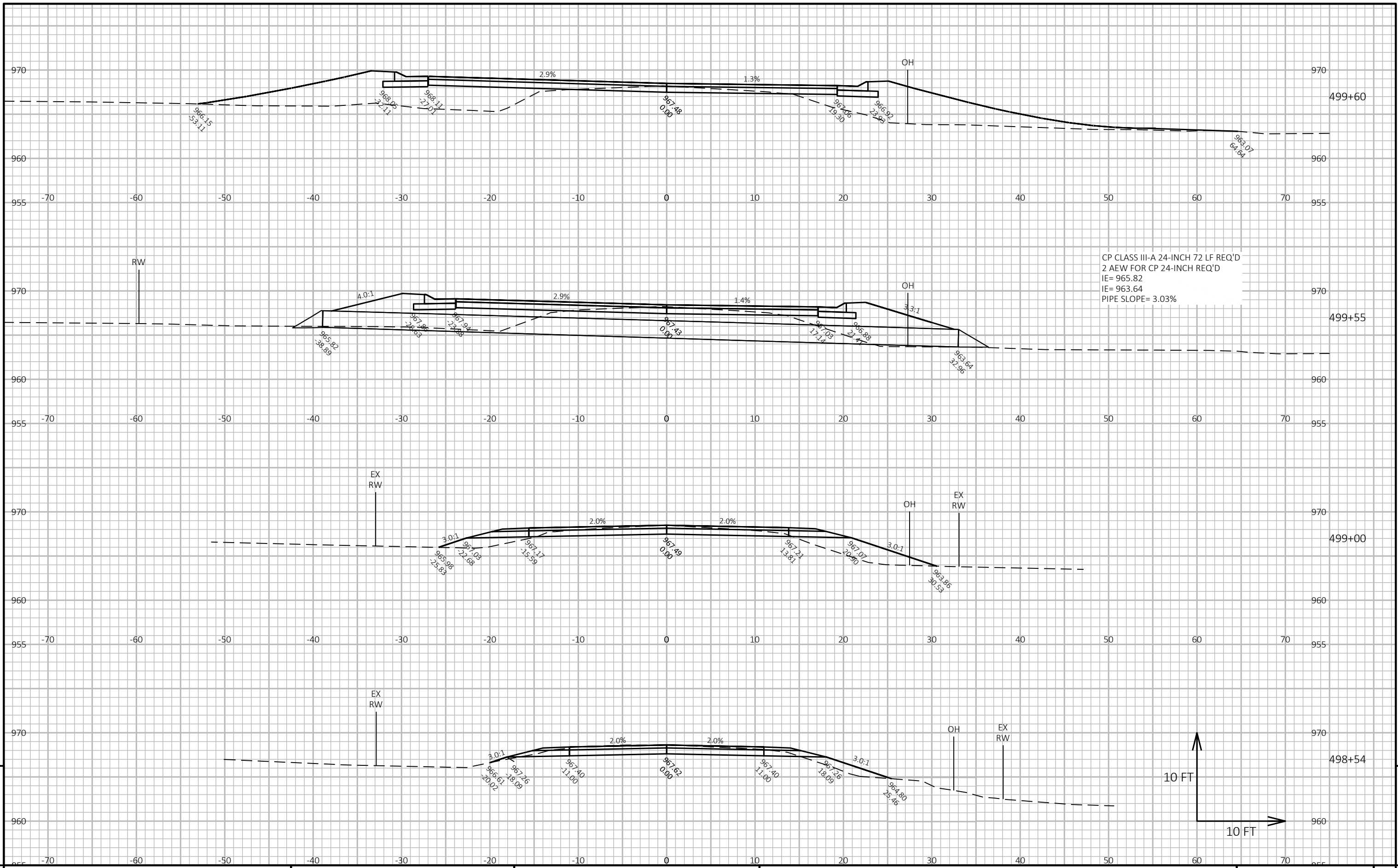

9

9

PROJECT NO: 7880-07-73 HWY: CTH H COUNTY: DUNN CROSS SECTIONS: 630TH AVE SHEET E

FILE NAME: C:\OD\CORRE, INC\PROJECTS - DOCUMENTS\WI - NW REGION\7880-07-03_DUNN CO_CTH H\500_CADD\501_C3D_2018\78800703\SHEETS\PLAN\090202-XS.DWG PLOT DATE: 10/18/2021 12:00 PM PLOT BY: NICHOLAS WATKHE PLOT NAME: PLOT SCALE: 1 IN:10 FT HORZ. / 1 IN:10 FT VERT.

WISDOT/CADD SHEET 49

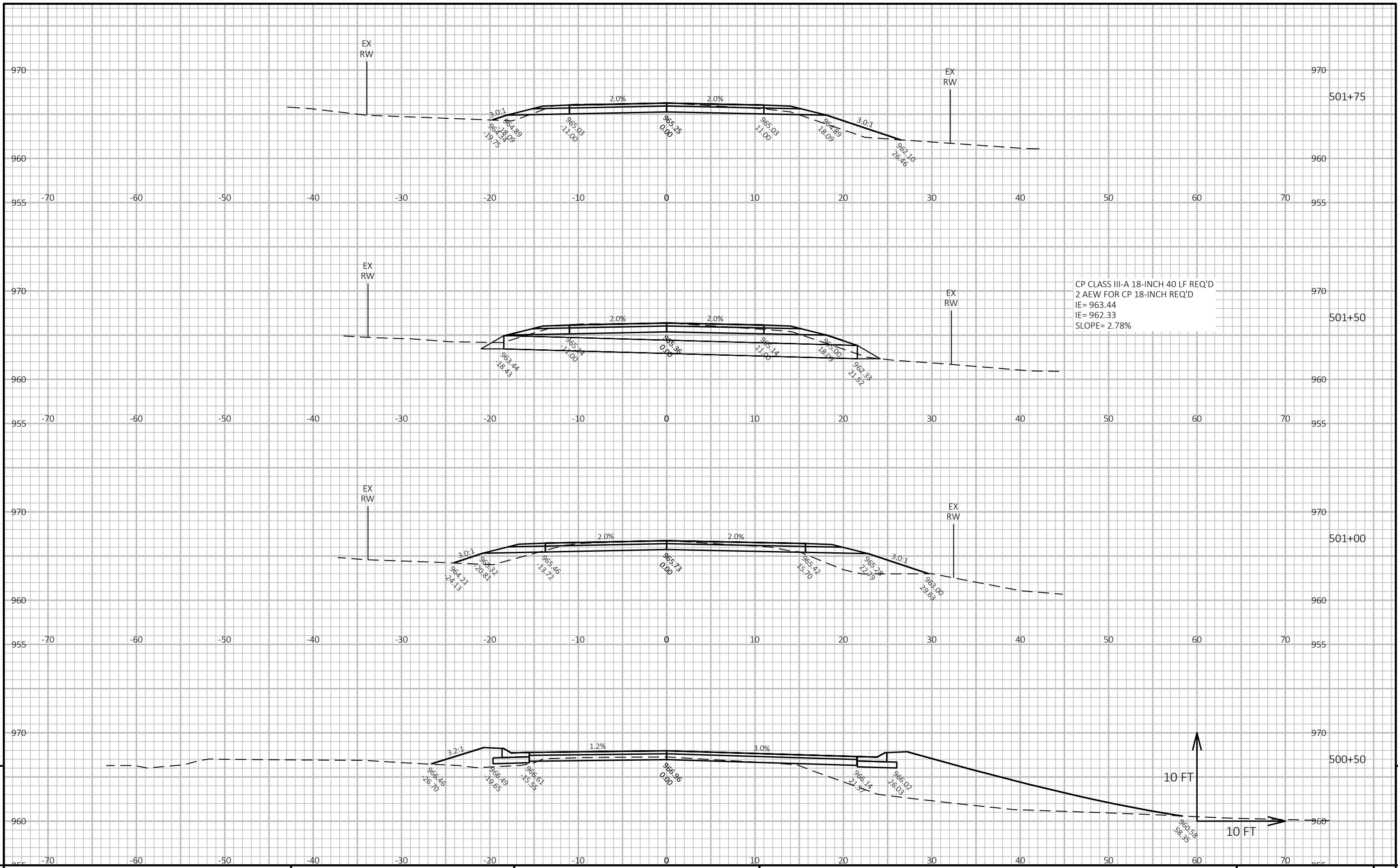

CP CLASS III-A 18-INCH 40 LF REQ'D
 2 AEW FOR CP 18-INCH REQ'D
 IE=963.44
 IE=962.33
 SLOPE=2.78%

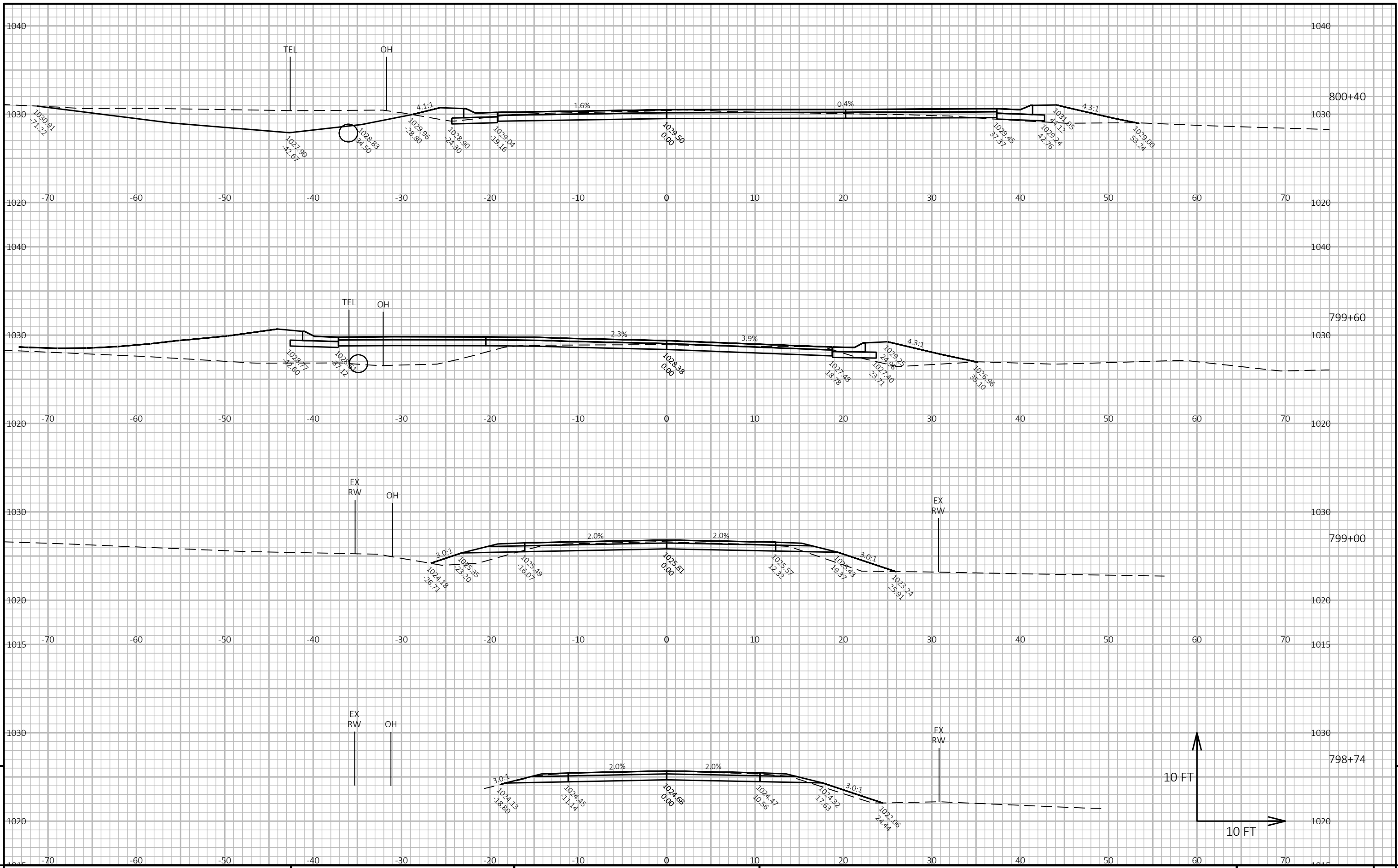

PROJECT NO: 7880-07-73

HWY: CTH H

COUNTY: DUNN

CROSS SECTIONS: 690TH AVE

SHEET

E

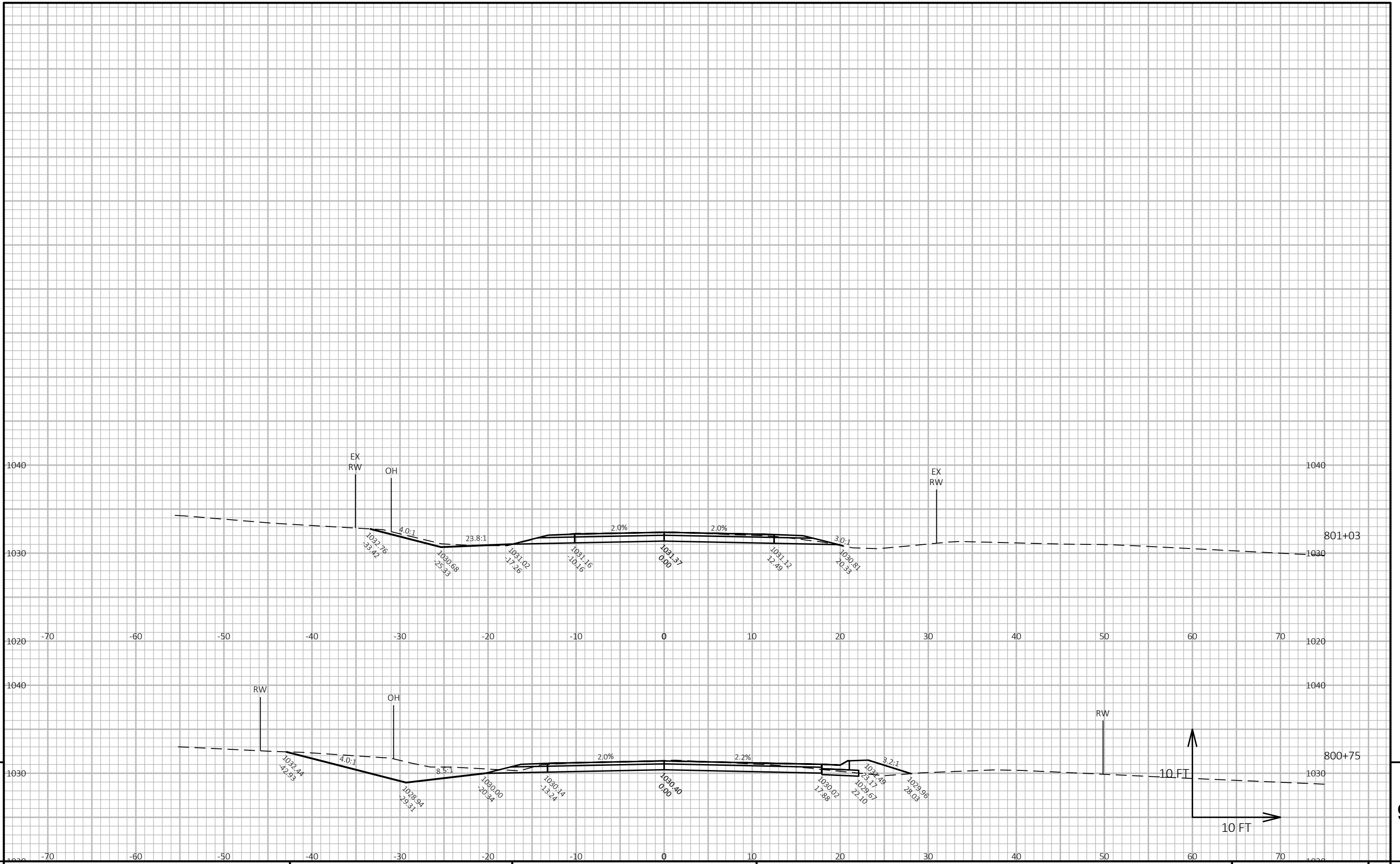

PROJECT NO: 7880-07-73

HWY: CTH H

COUNTY: DUNN

CROSS SECTIONS: 690TH AVE

SHEET

E



Wisconsin Department of Transportation

Dedicated people creating transportation solutions through innovation and exceptional service.

<http://www.dot.wisconsin.gov>