

LAX
PROJECT ID:
5305-00-71

FEBRUARY 2024

ORDER OF SHEETS

Section No.	1	Title
Section No.	2	Typical Sections and Details
Section No.	3	Estimate of Quantities
Section No.	3	Miscellaneous Quantities
Section No.	4	Right of Way Plat
Section No.	5	Plan and Profile
Section No.	6	Standard Detail Drawings
Section No.	7	Sign Plates
Section No.	8	Structure Plans
Section No.	9	Computer Earthwork Data
Section No.	9	Cross Sections

TOTAL SHEETS = 120

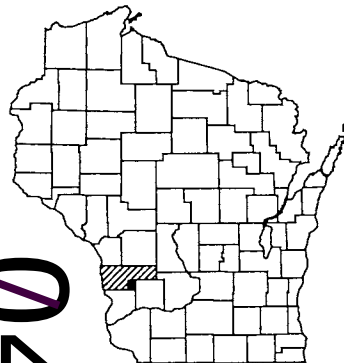

04

DESIGN DESIGNATION 5295-00-01

A.A.D.T.	2022	=	190
A.A.D.T.	2042	=	210
D.H.V.		=	21
D.D.		=	50/50
T.		=	23%
DESIGN SPEED		=	40 MPH
ESALS		=	59,000

CONVENTIONAL SYMBOLS

PLAN	PROFILE
CORPORATE LIMITS	GRADE LINE
PROPERTY LINE	ORIGINAL GROUND
LOT LINE	MARSH OR ROCK PROFILE (To be noted as such)
LIMITED HIGHWAY EASEMENT	SPECIAL DITCH
EXISTING RIGHT OF WAY	GRADE ELEVATION
PROPOSED OR NEW R/W LINE	CULVERT (Profile View)
SLOPE INTERCEPT	UTILITIES
REFERENCE LINE	ELECTRIC
EXISTING CULVERT	FIBER OPTIC
PROPOSED CULVERT (Box or Pipe)	GAS
COMBUSTIBLE FLUIDS	SANITARY SEWER
MARSH AREA	STORM SEWER
WOODED OR SHRUB AREA	TELEPHONE
	WATER
	UTILITY PEDESTAL
	POWER POLE
	TELEPHONE POLE

STATE OF WISCONSIN DEPARTMENT OF TRANSPORTATION

PLAN OF PROPOSED IMPROVEMENT

T LIBERTY - STH 56

PEA VINE ROAD TO STH 56

CTH SS
VERNON

STATE PROJECT NUMBER
5305-00-71

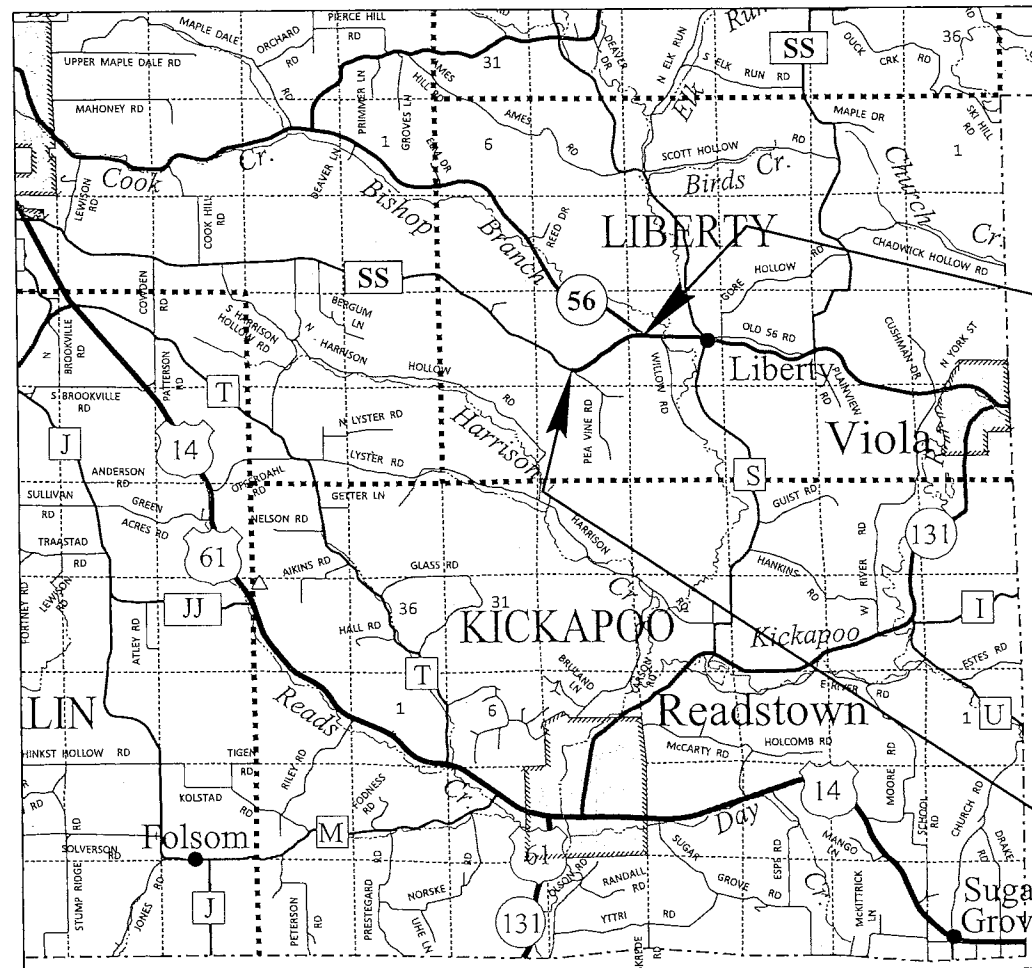

END PROJECT
STA 146+04'SS'

BEGIN PROJECT
STA 101+55'SS'
Y=735,863.1962
X=132,934.1777

LAYOUT
SCALE 0 2 MI
TOTAL NET LENGTH OF CENTERLINE = 0.843 MILES

HORIZONTAL POSITIONS SHOWN ON THIS PLAN ARE WISCONSIN COORDINATE REFERENCE SYSTEM (WISCRS), VERNON COUNTY, NAD83 (2011), IN U.S. SURVEY FEET. POSITIONS SHOWN ARE GRID COORDINATES, GRID BEARINGS, AND GRID DISTANCES. GRID DISTANCES ARE THE SAME AS GROUND DISTANCES.

ELEVATIONS ARE REFERENCED TO NAVD 88 (2012). GPS DERIVED ELEVATIONS ARE BASED ON GEOID 18

STATE PROJECT	FEDERAL PROJECT	
	PROJECT	CONTRACT
5305-00-71	WISC 2024251	1

ACCEPTED FOR

COUNTY of VERNON

10/9/23 *Phil Hewitt*
Hwy Comm
(Date) (Signature & Title of Official)

ORIGINAL PLANS PREPARED BY

SEH Short Elliott Hendrickson Inc.
329 Jay Street, Suite 301
La Crosse, WI 54601-4007
Building a Better World 608.782.3161 main | 888.908.8166 fax
for All of Us™ www.sehinc.com



10/4/2023 *Aleigha J. Burg*
(Date) (Signature)

STATE OF WISCONSIN
DEPARTMENT OF TRANSPORTATION

PREPARED BY	SEH
Surveyor	SEH
Designer	DAVID SCHMIDT
Project Manager	SW REGION
Regional Examiner	KYLE HEMP
Regional Supervisor	

APPROVED FOR THE DEPARTMENT
DATE: 10/10/23 *David Schmidt*
(Signature)

E

STANDARD ABBREVIATIONS

Table of standard abbreviations including ABUT, AC, AGG, AECPCRC, AECPCS, ASPH, AVG, ADT, BF, BM, BR, CE, C/L, Δ, COB, CONC, CPCS, CPRC, CPRCHE, CR, CY, C&G, D, DHV, DISCH, DG, DWY, X, EAT, EOR, EL, ENT, ESALS, EXC, EBS, EXIST, FC, FF, FERT, FE, FL, FO, CWT, HYD, ID, INV, IP, LHF, L, LF, LC, LS, MH, MOR, NC, NO, OBLIT, PACS, PAVT, PE, PVRC, QOR, R, REQ'D, RES, RHF, R/W, R, RDWY, R/L, SALV, SAN, SF, SY, SDD, STA, SS, SSPRC, SE, TC, T OR TN, T, TYP, VAR, VC, Y, YD.

DNR AREA LIAISON:

WI DEPT OF NATURAL REASOURCES
KAREN KALVELAGE
3550 MORMON COULEE ROAD
LA CROSSE, WI 54601
PHONE: (608) 785-9115
EMAIL: KAREN.KALVELAGE@WISCONSIN.GOV

WISDOT CONTACT:

WI DEPT OF TRANSPORTATION
DAVID B. SCHMIDT
210 WRIGHT STREET
MADISON, WI 53704
PHONE: (608) 246-3867
EMAIL: DAVID2.SCHMIDT@DOT.WI.GOV

VERNON COUNTY:

VERNON COUNTY HIGHWAY COMMISSIONER
PHIL HEWITT
1335 RAILROAD AVENUE
VIROQUA, WI 54665
PHONE: (608) 637-5452
EMAIL: VCHD@VERNONCOUNTY.ORG

DESIGN CONTACT:

SHORT ELLIOTT HENDRICKSON INC.
ALEIGHA BURG
329 JAY STREET, SUITE 301
LA CROSSE, WI 54601
PHONE: (608) 498-4804
EMAIL: ABURG@SEHINC.COM

UTILITY CONTACT LIST:

VERNON COMMUNICATIONS COOPERATIVE
103 N MAIN STREET
WESTBY, WI 54667
ATTENTION: SCOTT FREDRICK
TELEPHONE: 608.634.3136
EMAIL: SFREDERICK@VERNONCOM.COOP

VERNON ELECTRIC
110 SAUGSTAD ROAD
WESTBY, WI 53667
ATTENTION: COLE CARY
TELEPHONE: 608.634.7472
EMAIL: CCARY@VERNONELECTRIC.ORG



Dial 811 or (800)242-8511

www.DiggersHotline.com

GENERAL NOTES:

- 1. NO TREES OR SHRUBS SHALL BE REMOVED WITHOUT APPROVAL OF THE ENGINEER.
- 2. THE LOCATIONS OF EXISTING AND PROPOSED UTILITY INSTALLATIONS AS SHOWN ON THE PLANS ARE APPROXIMATE. THERE MAY BE OTHER UTILITY INSTALLATIONS WITHIN THE PROJECT AREA THAT ARE NOT SHOWN.
- 3. THE CONTRACTOR SHALL NOTIFY DIGGERS HOTLINE AND AFFECTED UTILITIES PRIOR TO THE START OF WORK. ANY LOCAL MUNICIPAL UTILITY WHICH IS NOT A MEMBER OF THE DIGGERS HOTLINE MUST BE CONTACTED SEPARATELY.
- 4. PRIOR TO ORDERING DRAINAGE PIPES AND STRUCTURES, THE CONTRACTOR SHALL VERIFY RELATED DRAINAGE INFORMATION IN THE PLANS WITH THE ENGINEER.
- 5. INLET AND DISCHARGE ELEVATIONS FOR DRAINAGE STRUCTURES SHOWN ON THE PLAN MAY BE ADJUSTED BY THE ENGINEER TO FIT FIELD CONDITIONS.
- 6. WETLANDS, WATERWAYS, AND OTHER ENVIRONMENTALLY SENSITIVE AREAS SHALL BE PROTECTED AT ALL TIMES. DO NOT STORE EQUIPMENT OR MATERIALS NEAR THESE SITES UNLESS APPROVED BY THE ENGINEER.
- 7. BROKEN CONCRETE CONTAINING RE-BAR SHALL NOT BE USED AS RIPRAP.
- 8. CROSS SECTIONS SHOWN INCLUDE THE THICKNESS OF TOPSOIL WHERE REQUIRED. TOPSOIL SHALL BE REPLACED WITH 4-INCH TYPICAL DEPTH.
- 9. TRAFFIC CONTROL DEVICES SHALL BE ADJUSTED TO FIT FIELD CONDITIONS AS DIRECTED BY THE ENGINEER.
- 10. REMOVAL OF EROSION CONTROL DEVICES IS INCLUDED IN THE COST OF THEIR RESPECTIVE BID ITEMS.
- 11. THE EROSION CONTROL FEATURES AS SHOWN IN THE PLANS ARE AT SUGGESTED LOCATIONS. EXACT LOCATIONS WILL BE DETERMINED BY THE ENGINEER IN THE FIELD.
- 12. ASPHALTIC SURFACES SHALL BE SAWCUT AT THE MATCH LINE AS SHOWN ON THE PLAN OR AS DIRECTED BY THE ENGINEER.
- 13. DISTURBED AREAS WITHIN THE RIGHT OF WAY, EXCEPT THE AREAS WITHIN THE FINISHED SHOULDER POINTS, SHALL BE SALVAGED TOPSOILED, FERTILIZED AND SEEDED.
- 14. FERTILIZER SHALL NOT BE USED NEAR NAVIGABLE WATERWAYS OR WETLANDS.
- 15. A CONVERSION FACTOR OF 2.0 TONS/CY IS USED TO ESTIMATE QUANTITIES FOR BAD 1 1/4-INCH AND 2.1 TONS/CY FOR BAD 3/4-INCH.
- 16. APPLY TACK COAT AT A RATE OF 0.07 GAL/SY TO MILLED SURFACE AND 0.05 GA/SY BETWEEN LAYERS OF HMA PAVEMENT.
- 17. HMA PAVEMENT WEIGHT CALCULATIONS ARE BASED ON 112 LB/SY/IN.
- 18. THE CONTRACTOR'S PAVING OPERATIONS SHALL BE CONSISTENT WITH THE PLAN AND TYPICAL SECTIONS AND CONSTRUCTED TO PREVENT HMA LONGITUDINAL JOINTS FROM BEING LOCATED WITHIN A DRIVING, TURNING, PASSING OR PARKING LANE.

RUNOFF COEFFICIENT TABLE

Table with columns for Hydrologic Soil Group (A, B, C, D) and Slope Range (Percent). Rows include Land Use (ROW CROPS, MEDIAN STRIP-TURF, SIDE SLOPE-TURF), Pavement (ASPHALT, CONCRETE, BRICK, DRIVES, WALKS, ROOFS, GRAVEL ROADS, SHOULDERS), and a total project area of 11.4 acres.

BORING LOG

Table with columns: BORING NO., STATION, ASPHALTIC PAVEMENT DEPTH (IN), BASE DEPTH (IN), SUBBASE MATERIAL. Rows 8-1 through 8-13 showing depths and materials like BROWN CLAY, SAND, TAN SAND.

ORDER OF SHEETS - SECTION 2:

- GENERAL NOTES
- PROJECT OVERVIEW
- TYPICAL SECTIONS
- CONSTRUCTION DETAILS
- EROSION CONTROL
- PERMANENT SIGNING & PAVEMENT MARKING
- TRAFFIC CONTROL DETAILS

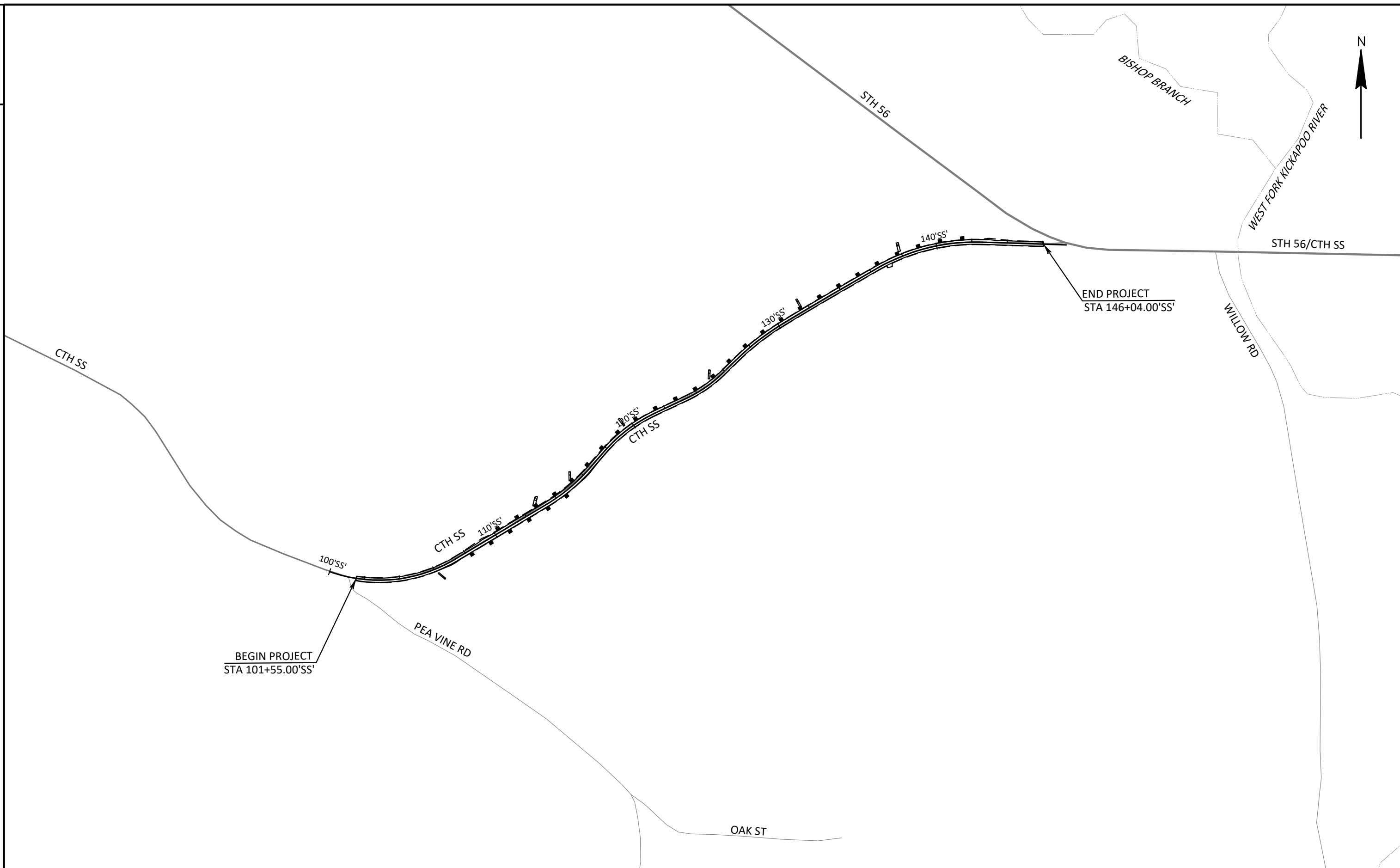

PROJECT NO: 5305-00-71

HWY: CTH SS

COUNTY: VERNON

PROJECT OVERVIEW

SHEET

E

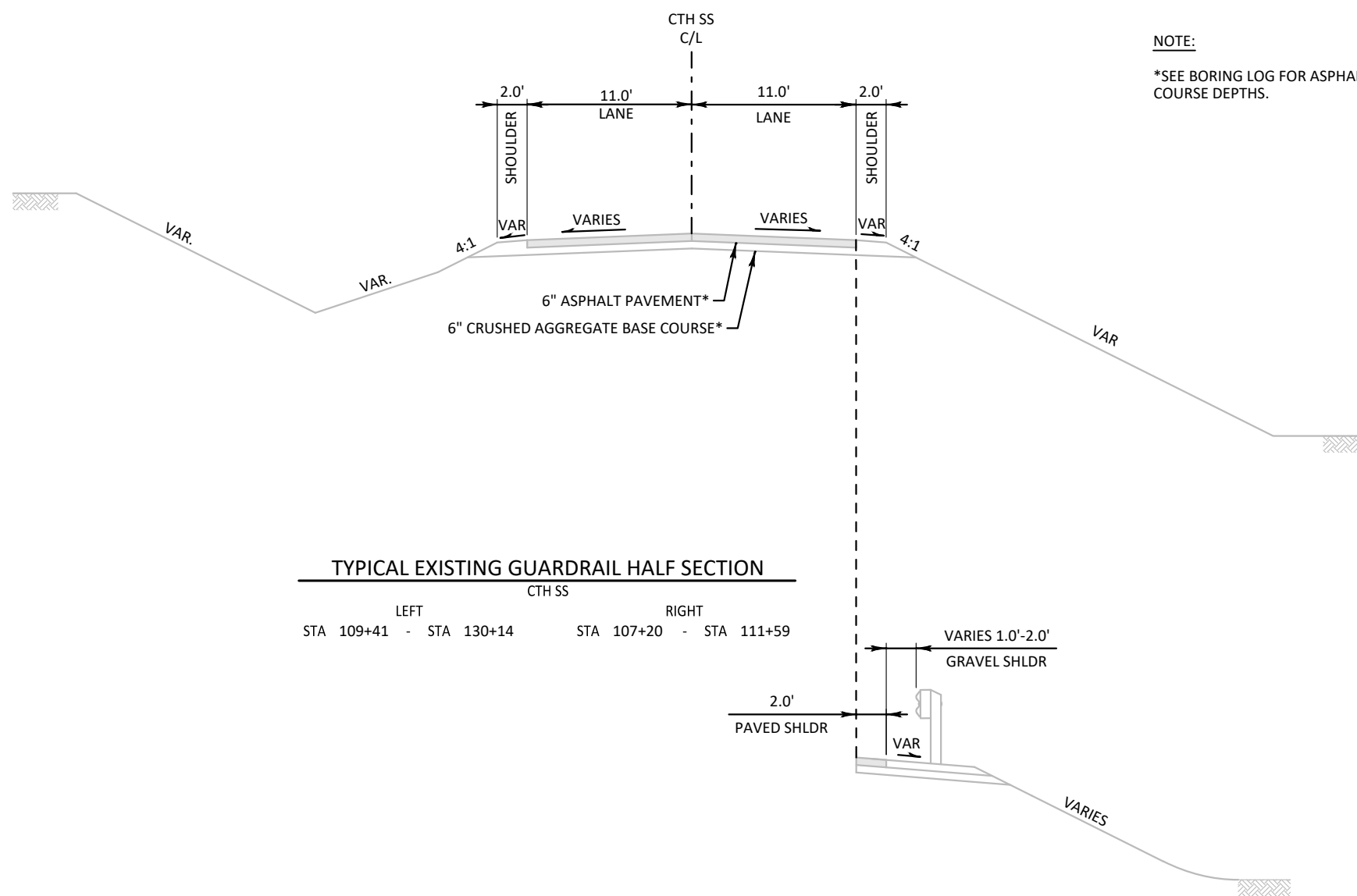

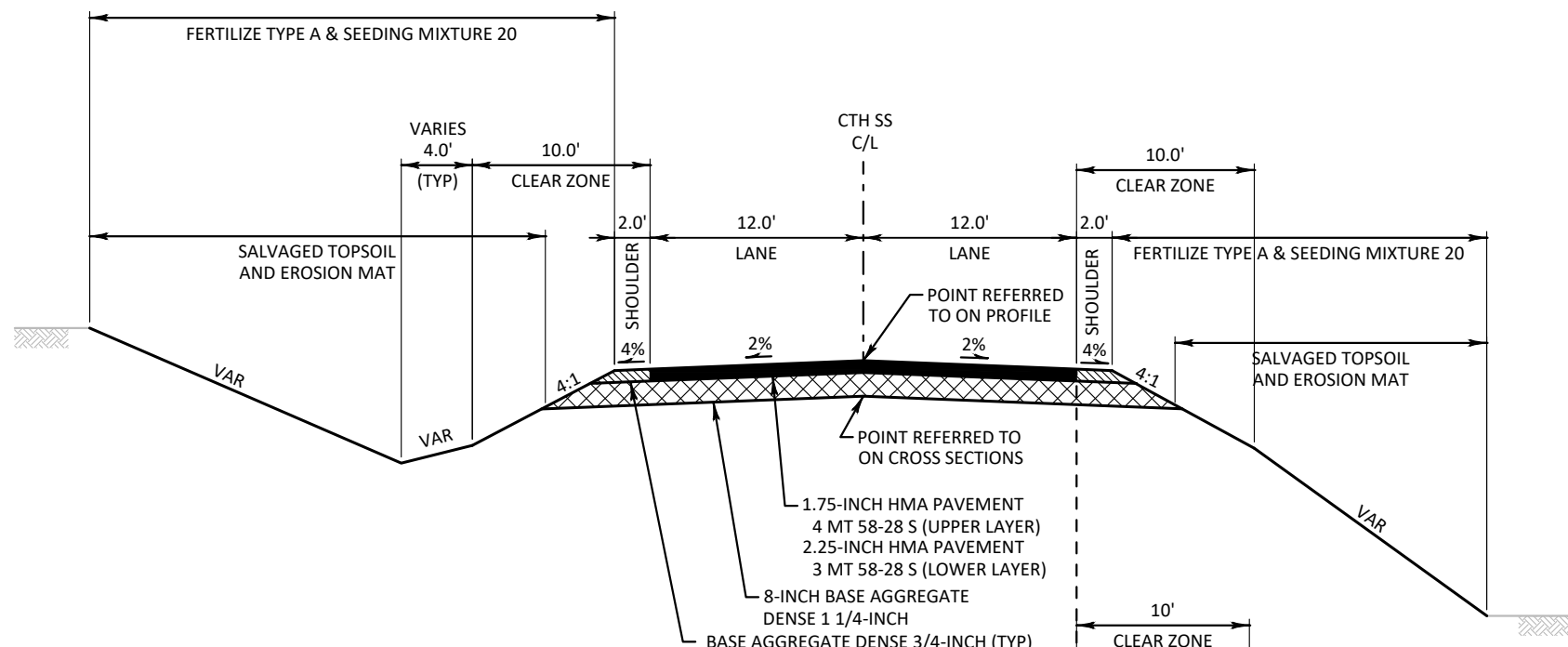

TYPICAL PROPOSED GUARDRAIL HALF SECTION

CTH SS
LEFT STA 119+00 - STA 142+96 RIGHT STA 107+06 - STA 116+20

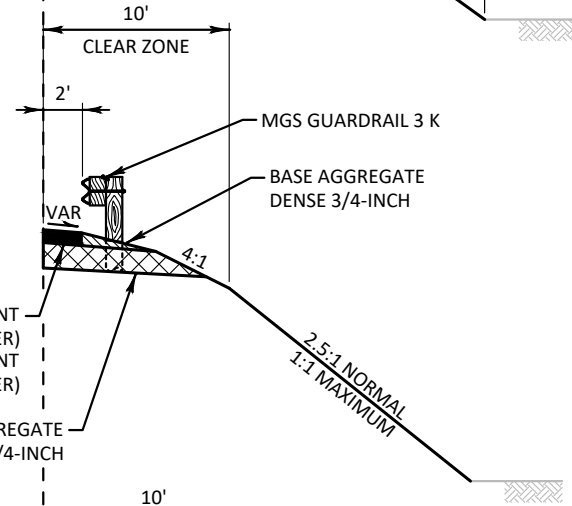

TYPICAL PROPOSED GUARDRAIL HALF SECTION

CTH SS
LEFT STA 109+23 - STA 119+00

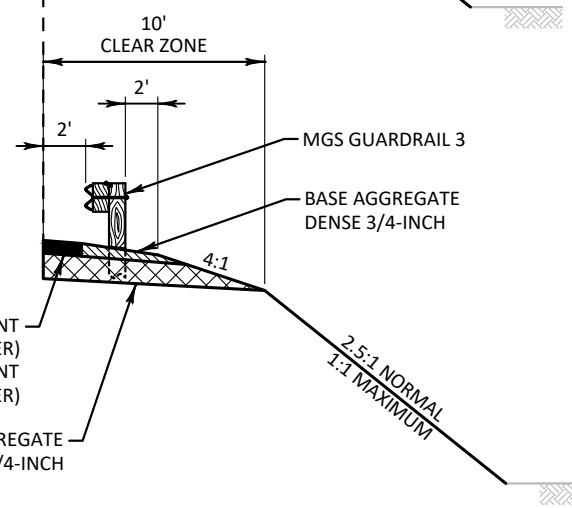

TYPICAL PROPOSED SECTION

CTH SS
STA 101+55 - STA 146+04

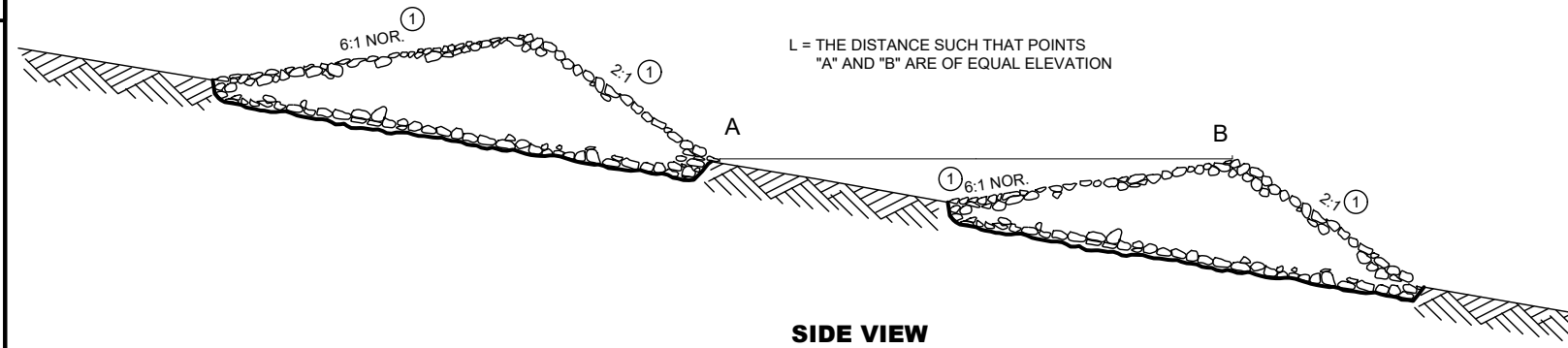

SIDE VIEW

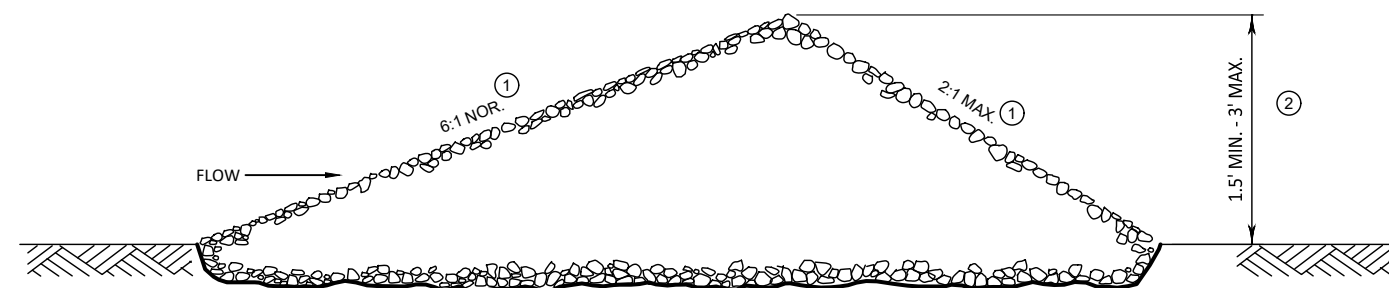

SIDE VIEW DETAIL

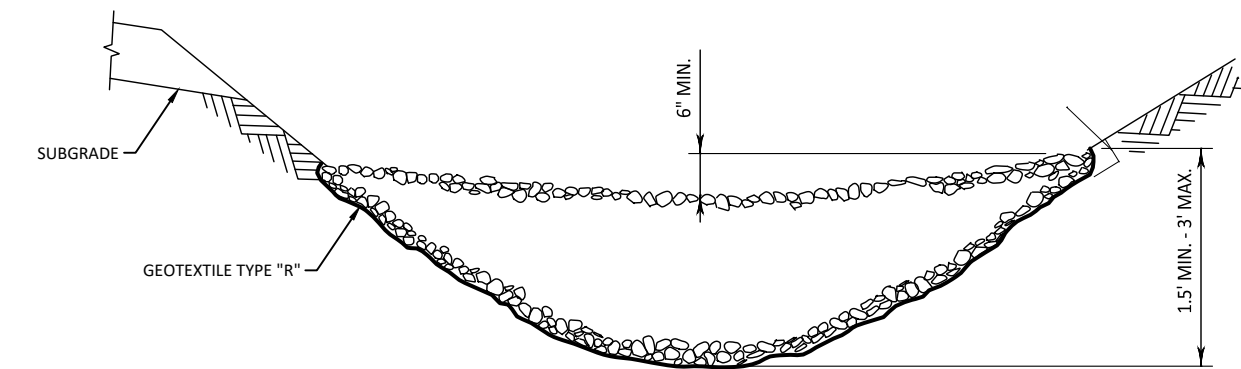

SECTION VIEW

STONE DITCH CHECK

- ① WHEN PLACED WITHIN THE CLEAR ZONE, SLOPED AT 6:1 OR FLATTER.
- ② MEASURED AT THE CENTER OF THE DITCH CHECK.

EBS WITH GEOGRID (STA 106+00 - 118+00)

NOTE:
WIDTHS NOT TO SCALE

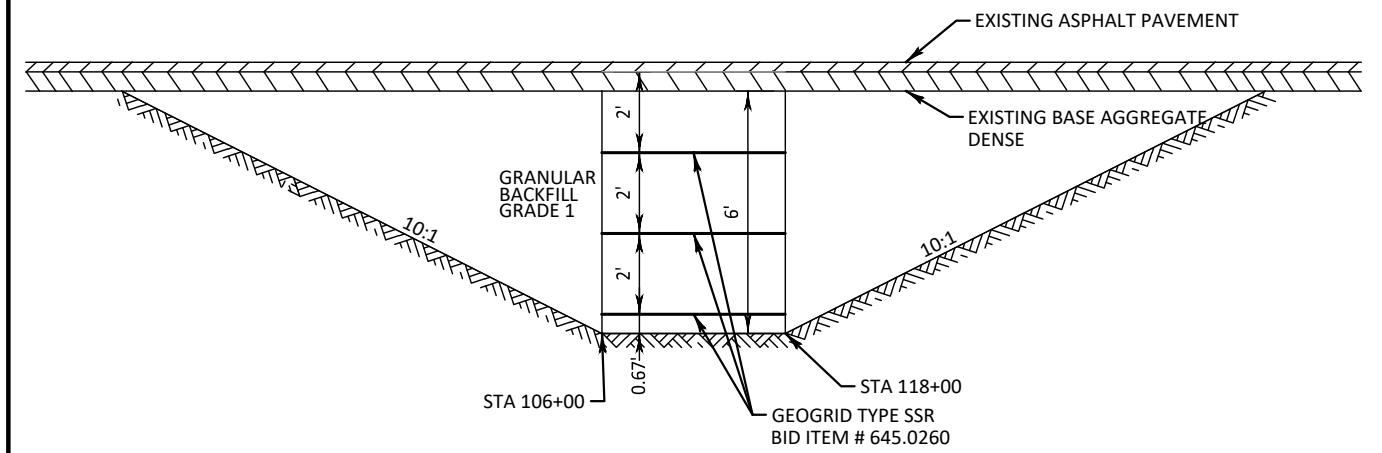

SIDE VIEW

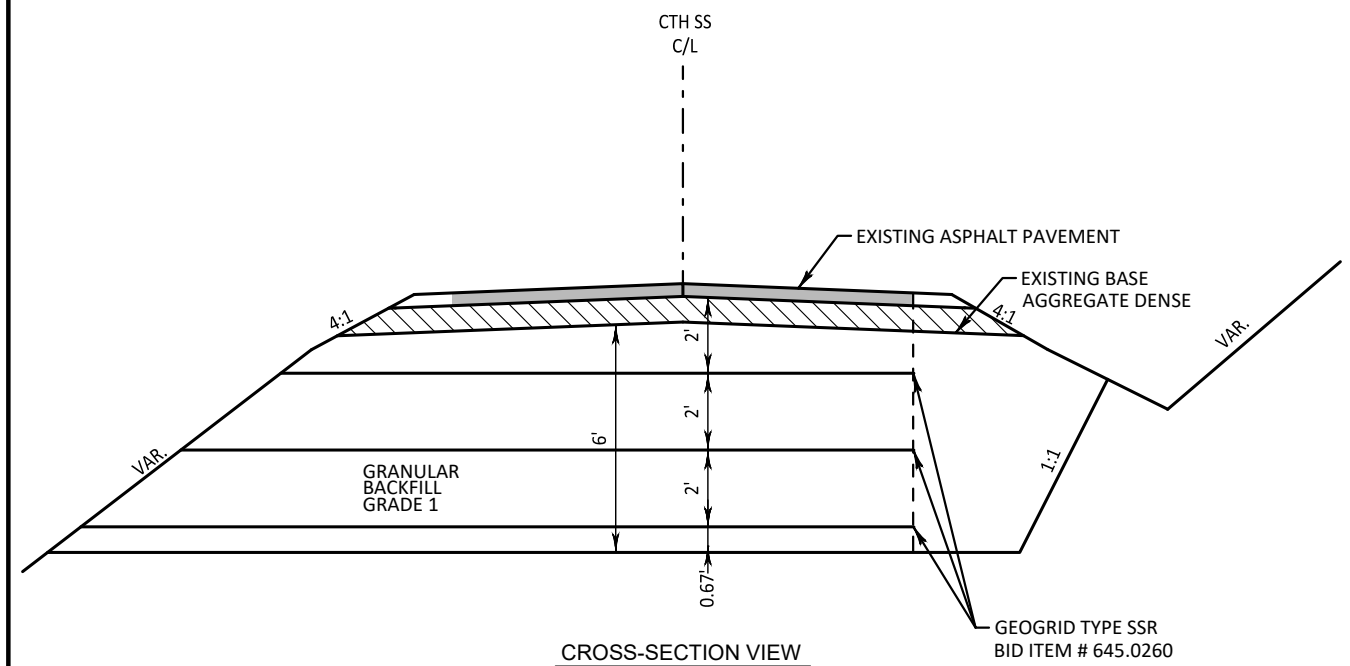

CROSS-SECTION VIEW

NOTE:
WHEN GEOGRID INTERSECTS WITH A CULVERT PIPE,
STOP THE GEOGRID IN CONFLICT WITH THE PIPE 2'
SHORT OF THE CULVERT PIPE.

EBS WITH GEOGRID (STA 124+50 - 127+50)

NOTE:
WIDTHS NOT TO SCALE

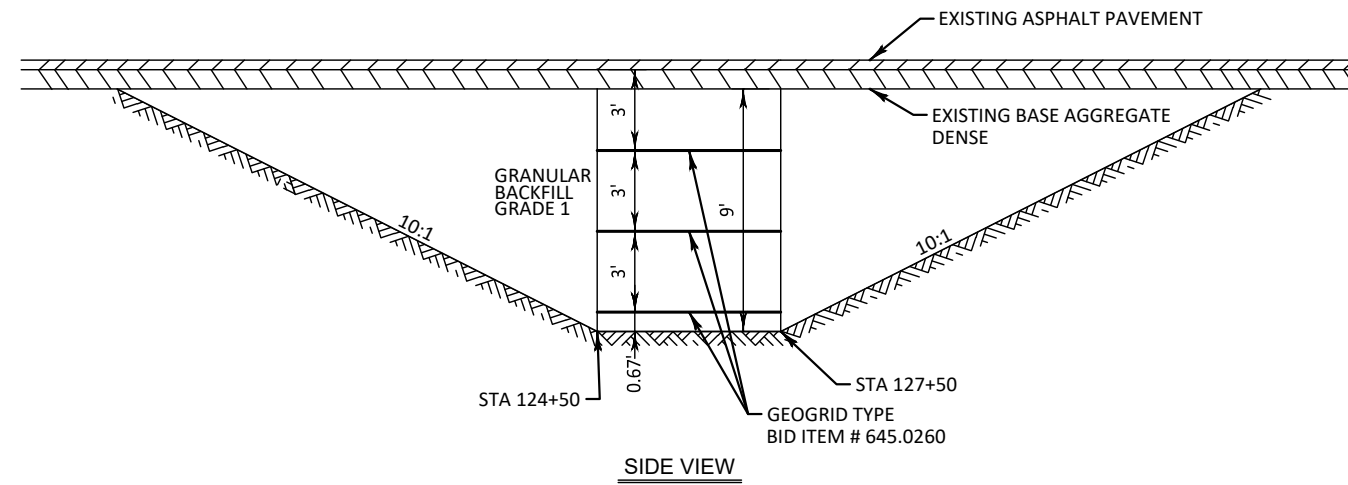

SIDE VIEW

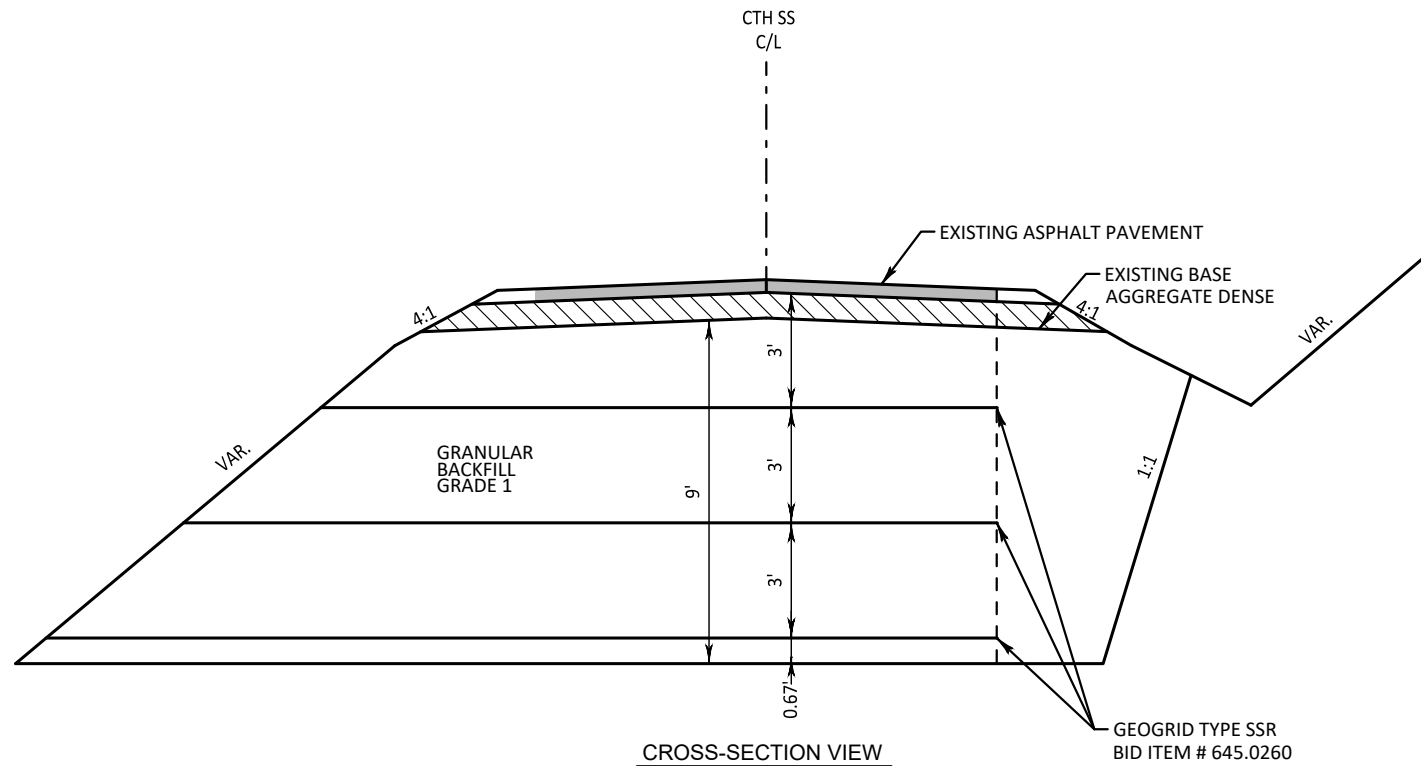

CROSS-SECTION VIEW

NOTE:
WHEN GEOGRID INTERSECTS WITH A CULVERT PIPE,
STOP THE GEOGRID IN CONFLICT WITH THE PIPE 2'
SHORT OF THE CULVERT PIPE.

EBS WITH GEOGRID (STA 137+00 - 139+00)

NOTE:
WIDTHS NOT TO SCALE

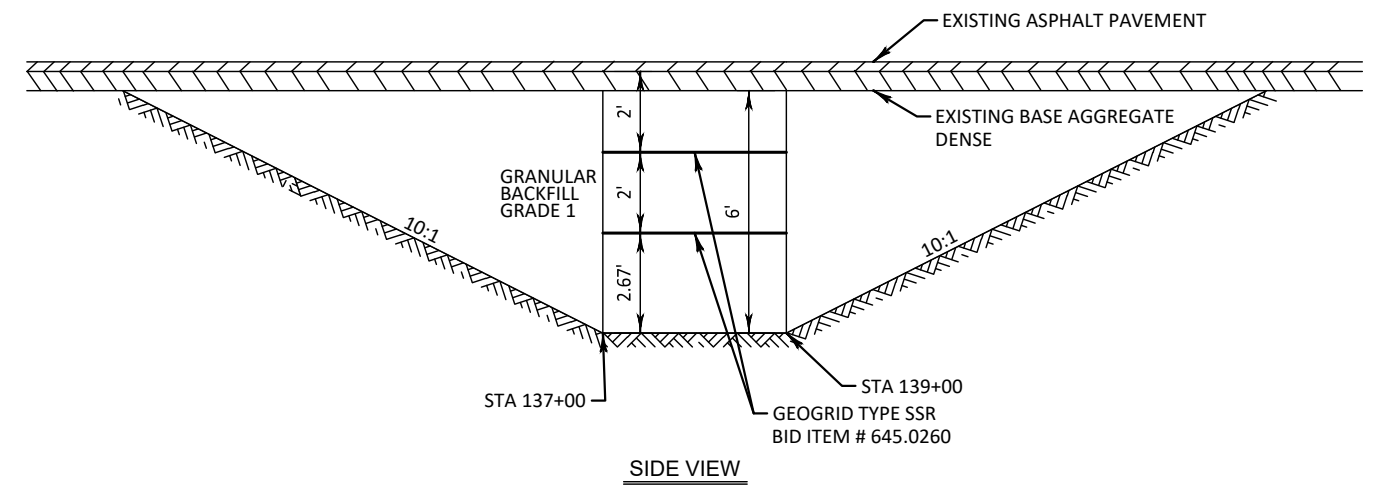

SIDE VIEW

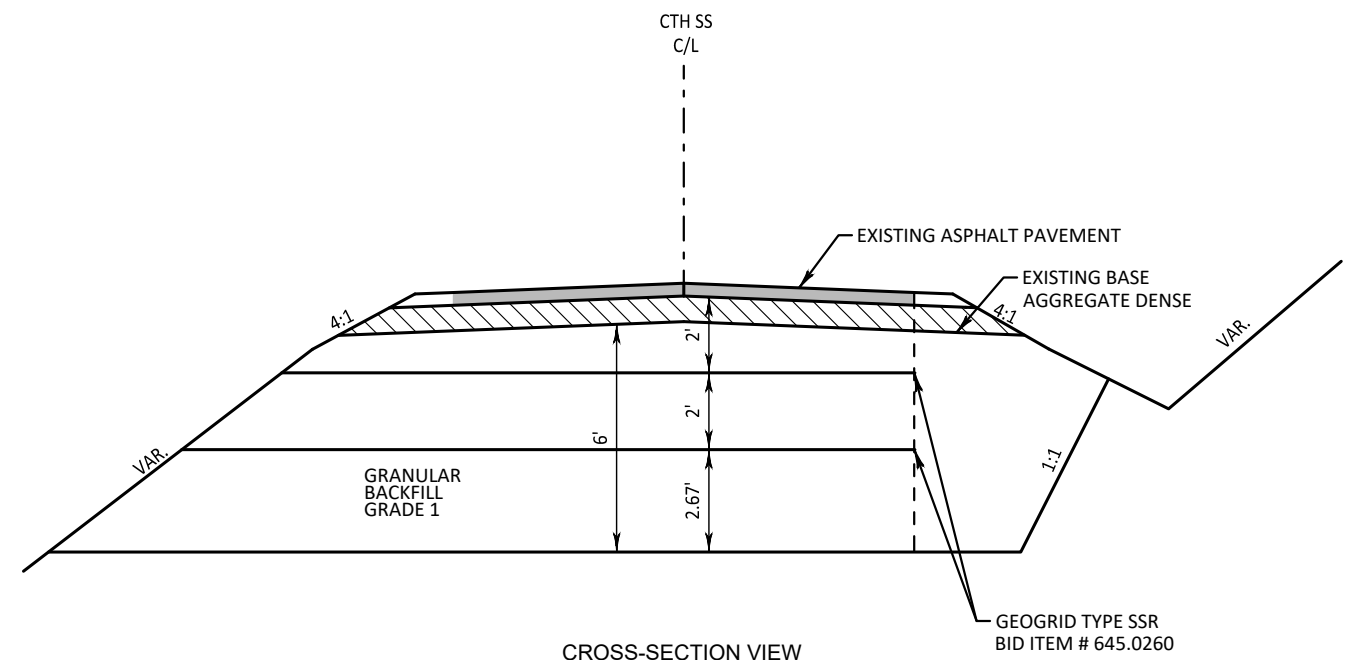

CROSS-SECTION VIEW

NOTE:
WHEN GEOGRID INTERSECTS WITH A CULVERT PIPE,
STOP THE GEOGRID IN CONFLICT WITH THE PIPE 2'
SHORT OF THE CULVERT PIPE.

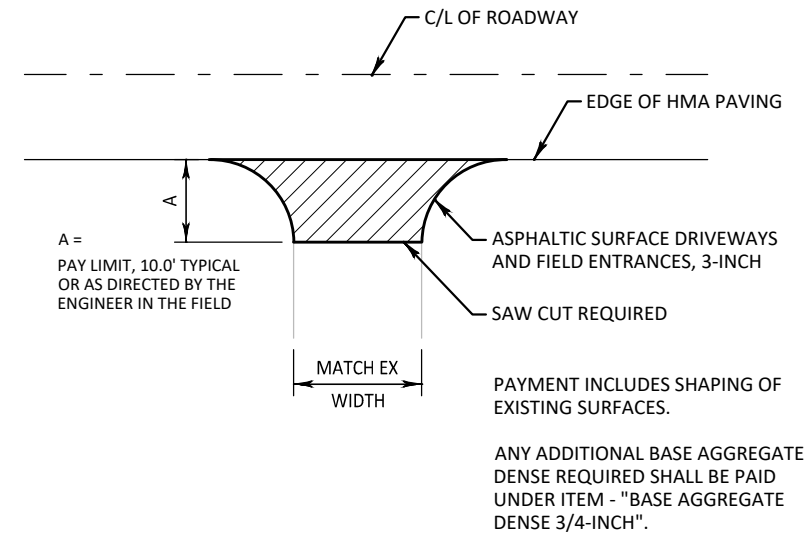

ASPHALTIC SURFACE DRIVEWAYS AND FIELD ENTRANCES
(PE, CE, OR FE)

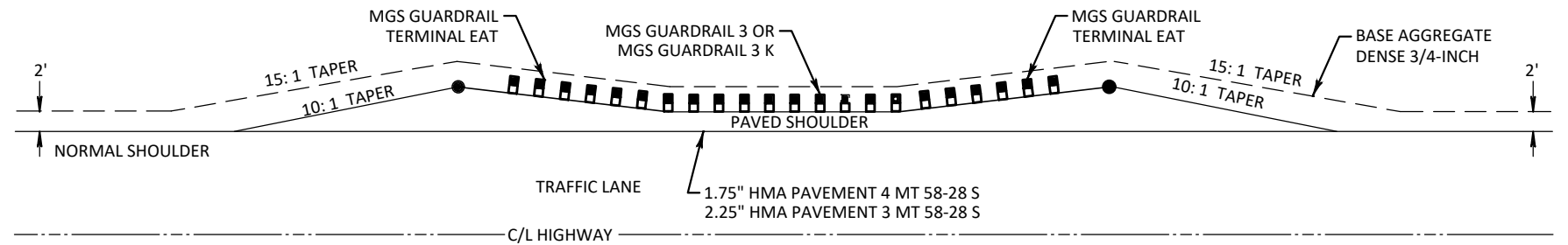
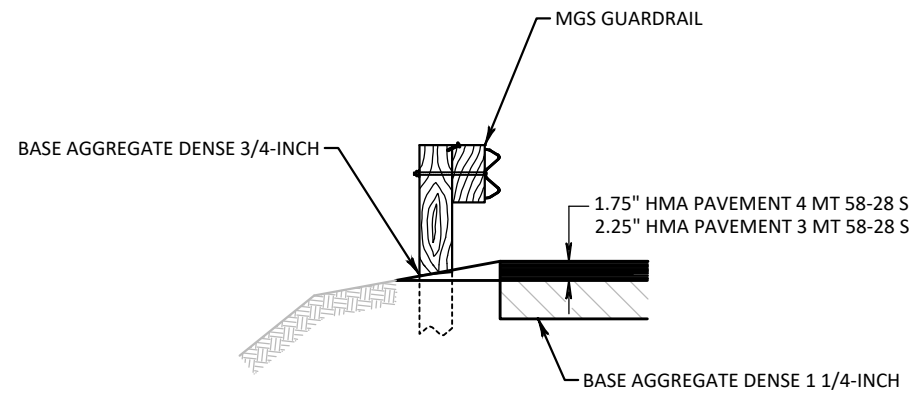

GUARDRAIL LAYOUT

NOTE:
SEE PLAN AND PROFILE SHEETS FOR EXACT OFFSETS
AND LAYOUT

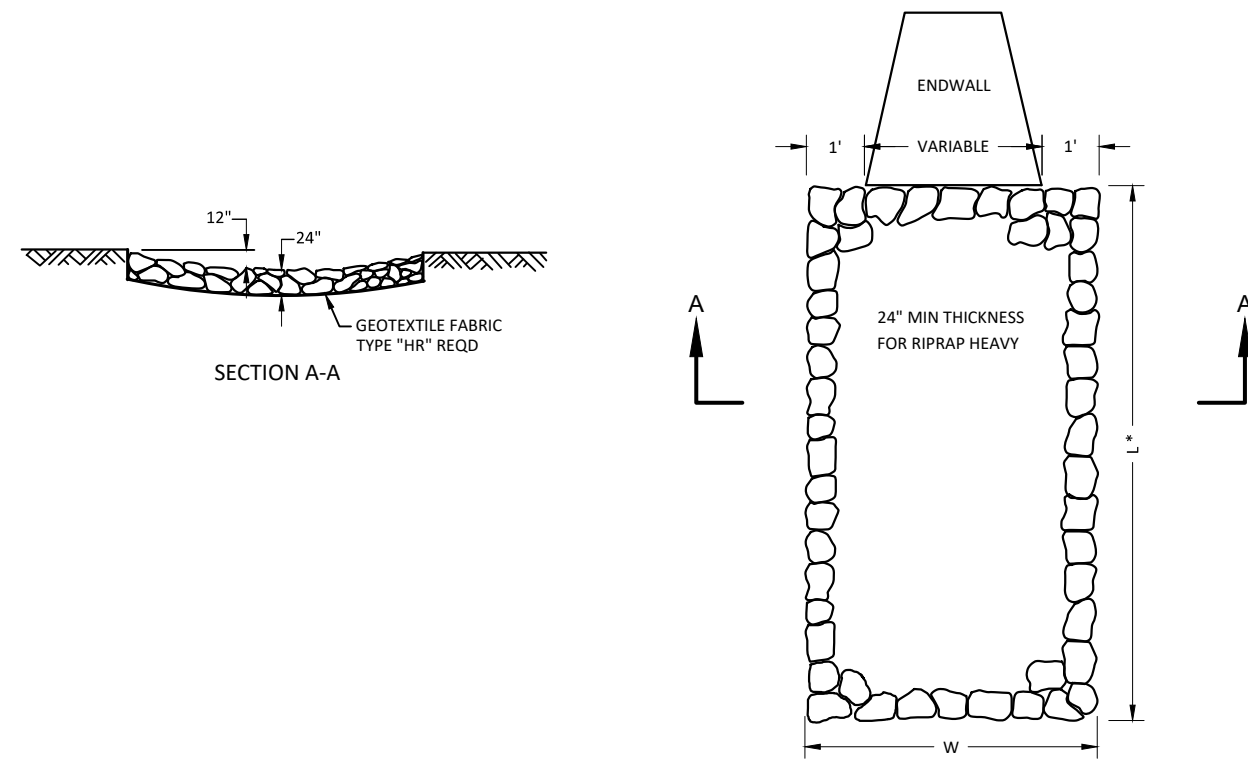

RIPRAP HEAVY TREATMENT AT CULVERTS

* = DIMENSION SHOWN ON EROSION CONTROL
DETAIL SHEETS.

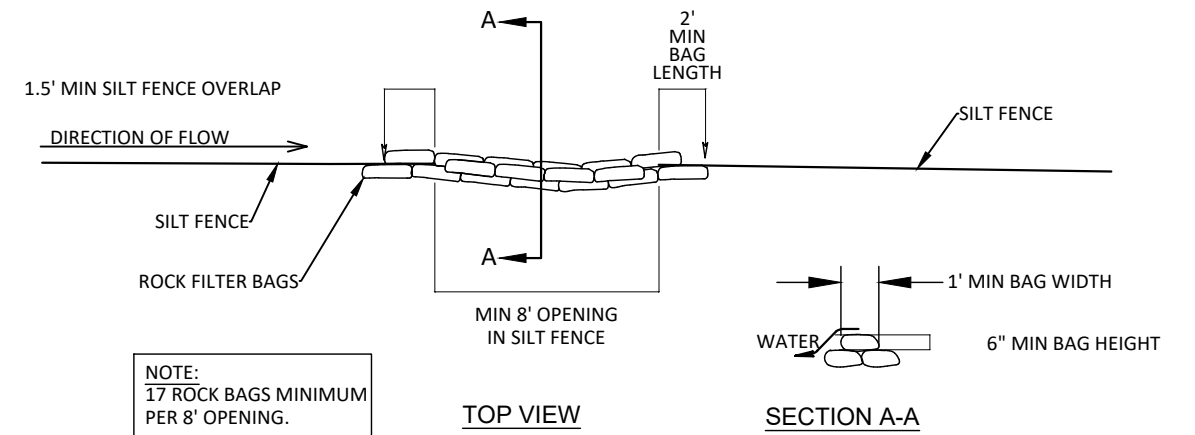

NOTE:
17 ROCK BAGS MINIMUM
PER 8' OPENING.

ROCK BAGS USED FOR SILT FENCE RELIEF

EROSION CONTROL NOTES:

PLACE SALVAGED TOPSOIL, SEED, AND FERTILIZER WITHIN ANY SURFACE SLOPE INTERCEPT AREAS THAT USE EROSION MAT.

DO NOT DRIVE EQUIPMENT OR STORE EQUIPMENT OR MATERIALS IN WETLANDS OR WATERWAYS.

PLACE SILT FENCE TWO FEET FROM THE SLOPE INTERCEPT WHERE APPROPRIATE.

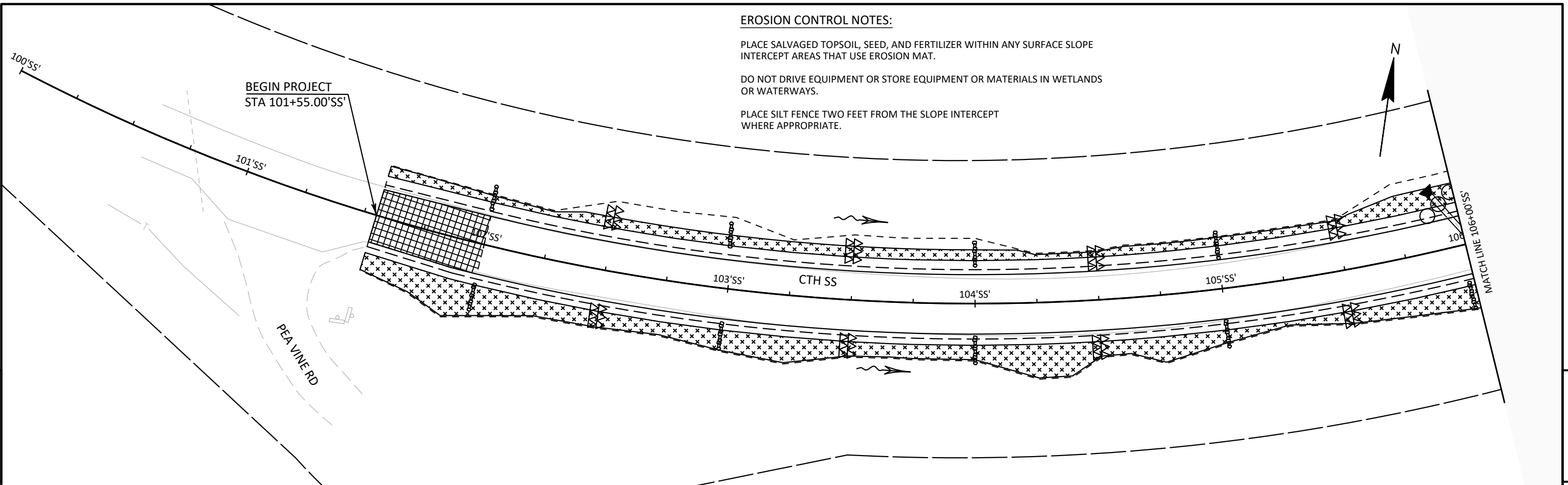

5

5

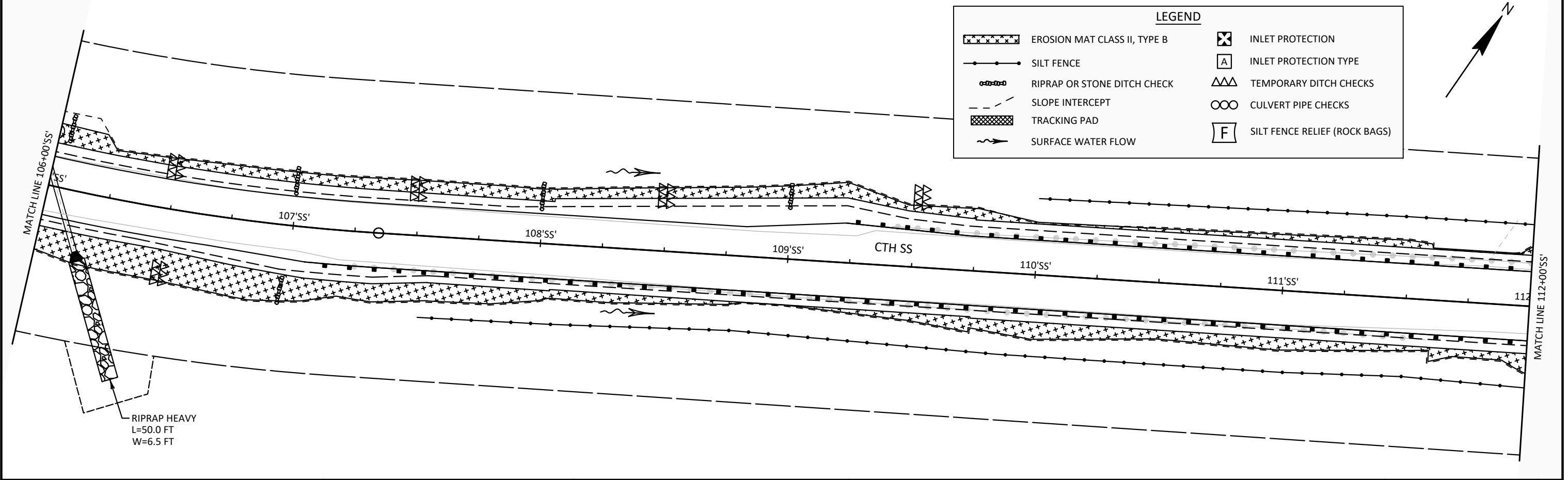

LEGEND

	EROSION MAT CLASS II, TYPE B		INLET PROTECTION
	SILT FENCE		INLET PROTECTION TYPE
	RIPRAP OR STONE DITCH CHECK		TEMPORARY DITCH CHECKS
	SLOPE INTERCEPT		CULVERT PIPE CHECKS
	TRACKING PAD		SILT FENCE RELIEF (ROCK BAGS)
	SURFACE WATER FLOW		

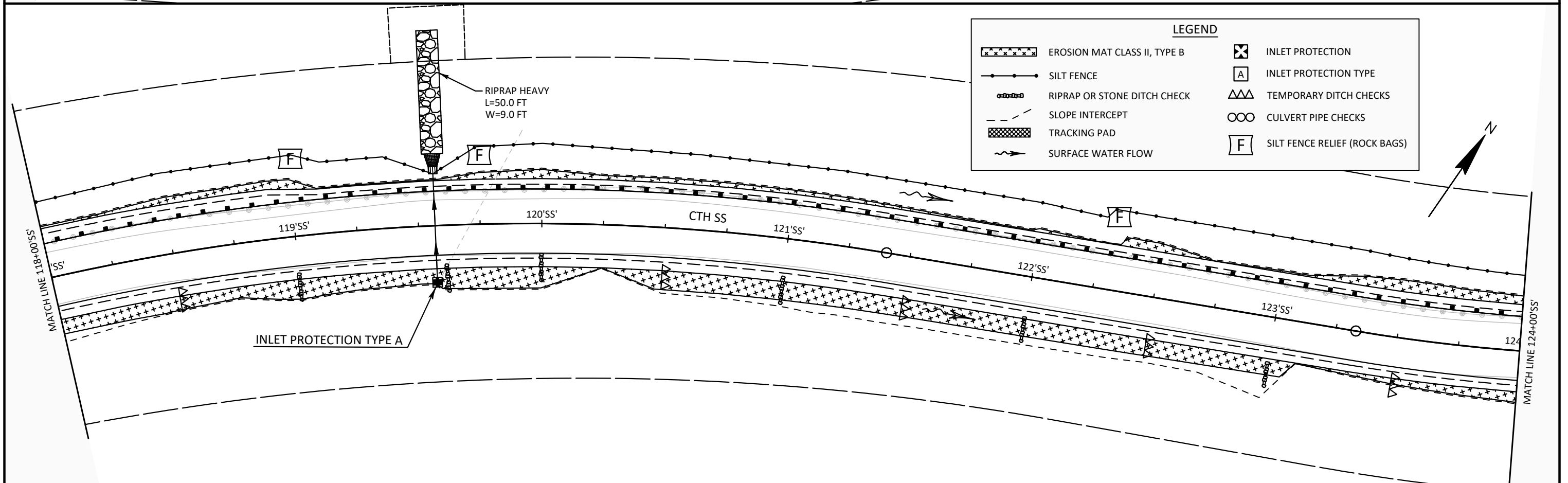
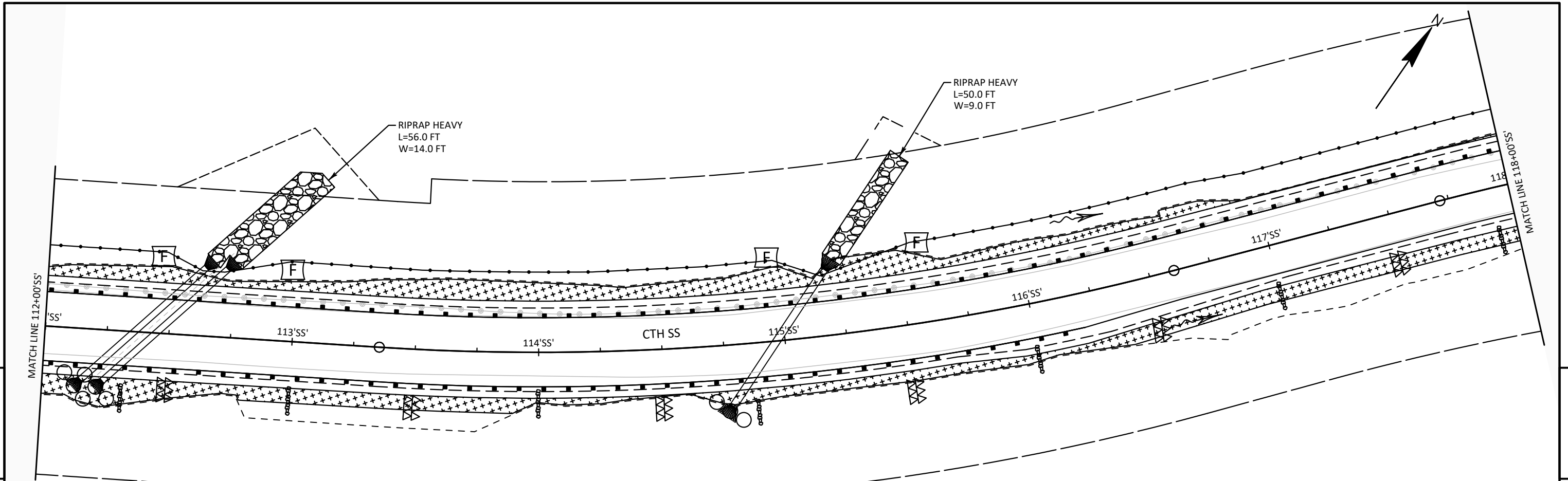

LEGEND	
	EROSION MAT CLASS II, TYPE B
	SILT FENCE
	RIPRAP OR STONE DITCH CHECK
	SLOPE INTERCEPT
	TRACKING PAD
	SURFACE WATER FLOW
	INLET PROTECTION
	INLET PROTECTION TYPE
	TEMPORARY DITCH CHECKS
	CULVERT PIPE CHECKS
	SILT FENCE RELIEF (ROCK BAGS)

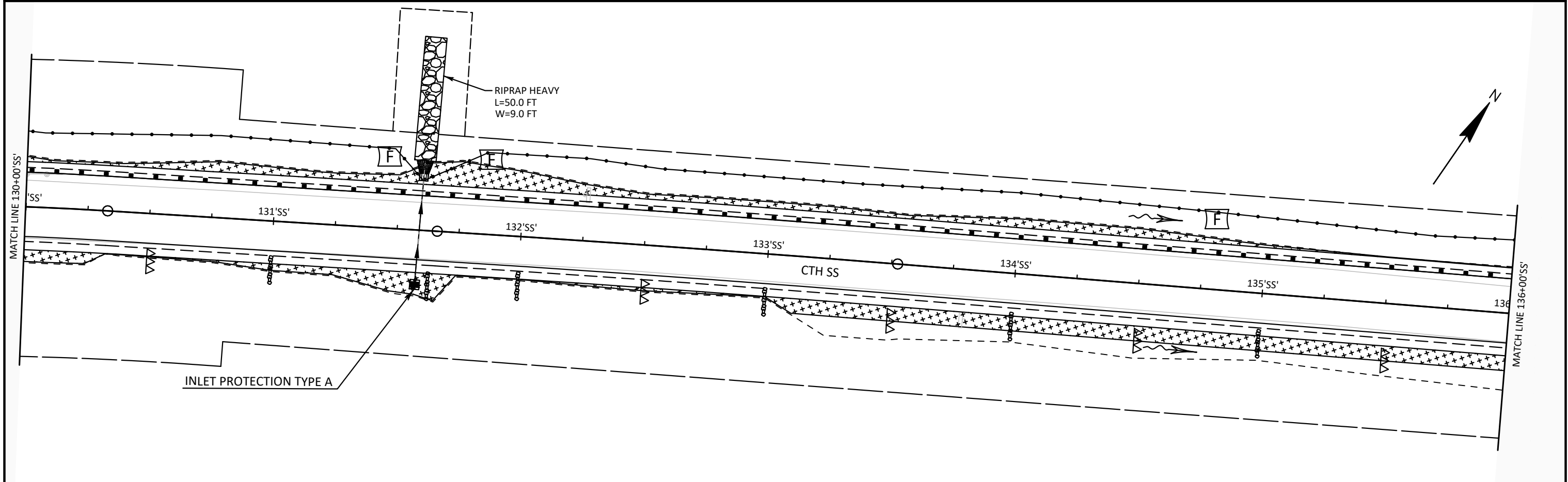
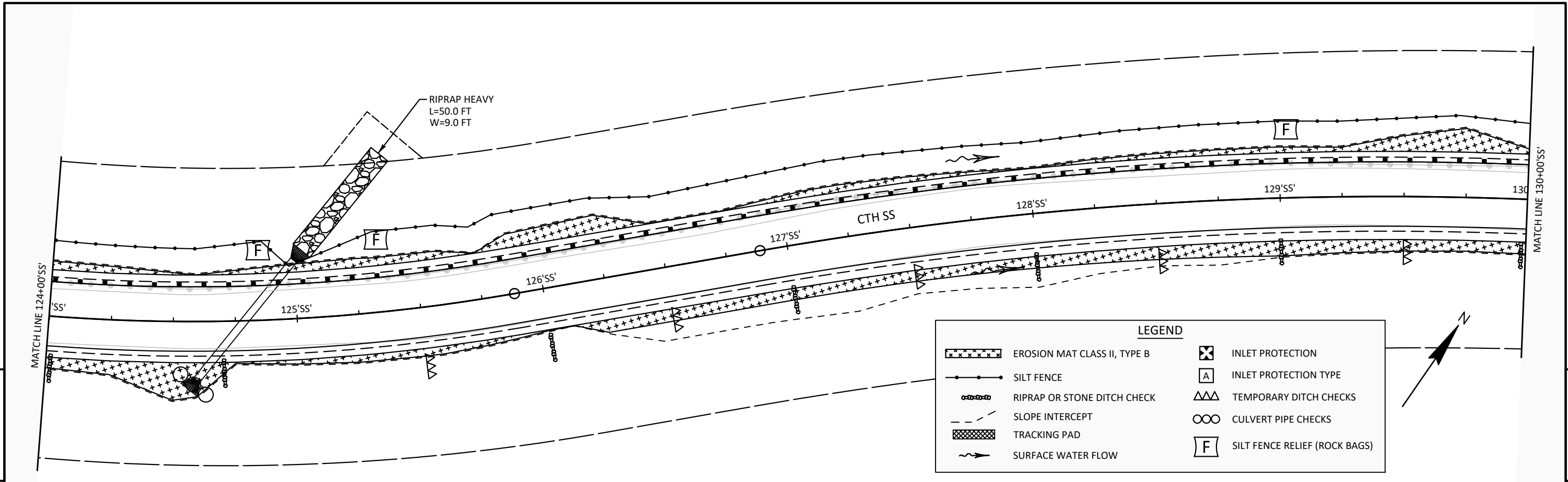

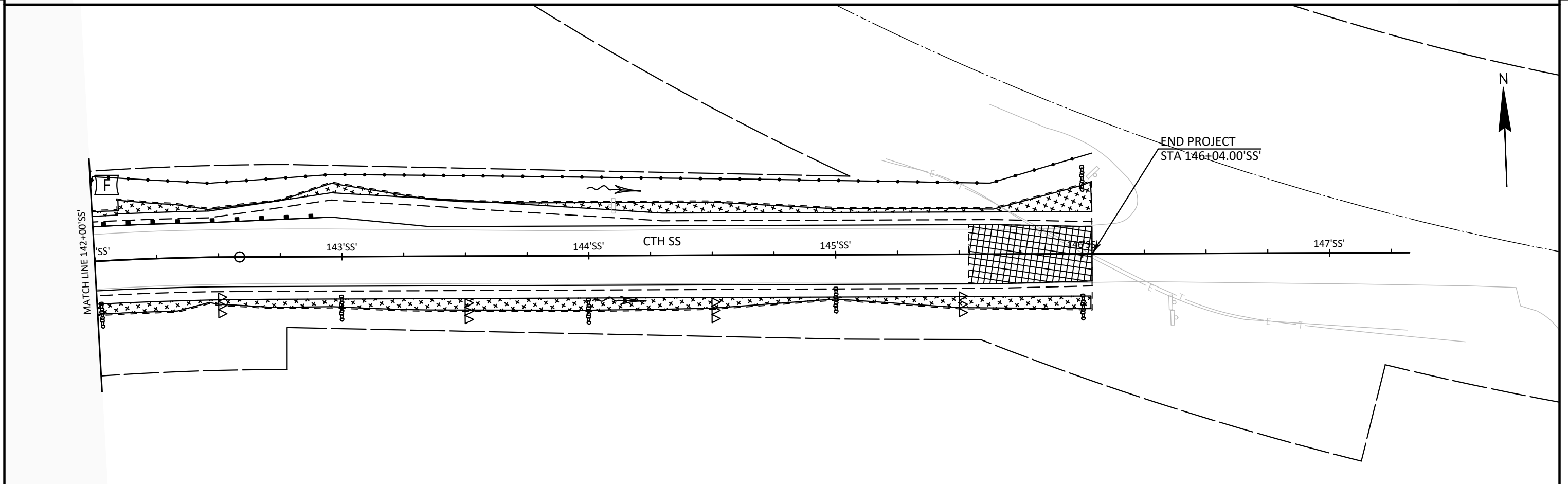
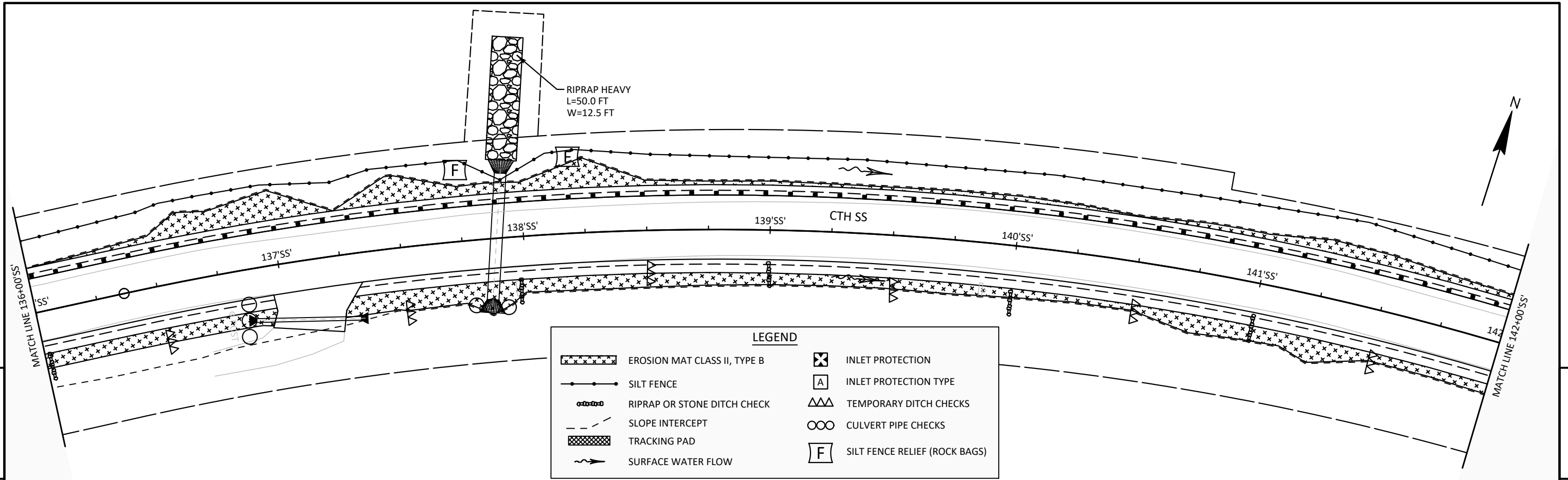

PERMANENT SIGNING LEGEND

-  EXISTING SIGN MOUNTED ON POST(S)
-  PROPOSED SIGN MOUNTED ON POST(S)
-  DENOTES SIGN NUMBER
-  SIGN COUNT SEQUENCE PER PAGE
-  PAGE NUMBER
-  WORK CODE: M=MOVE, R=REMOVE

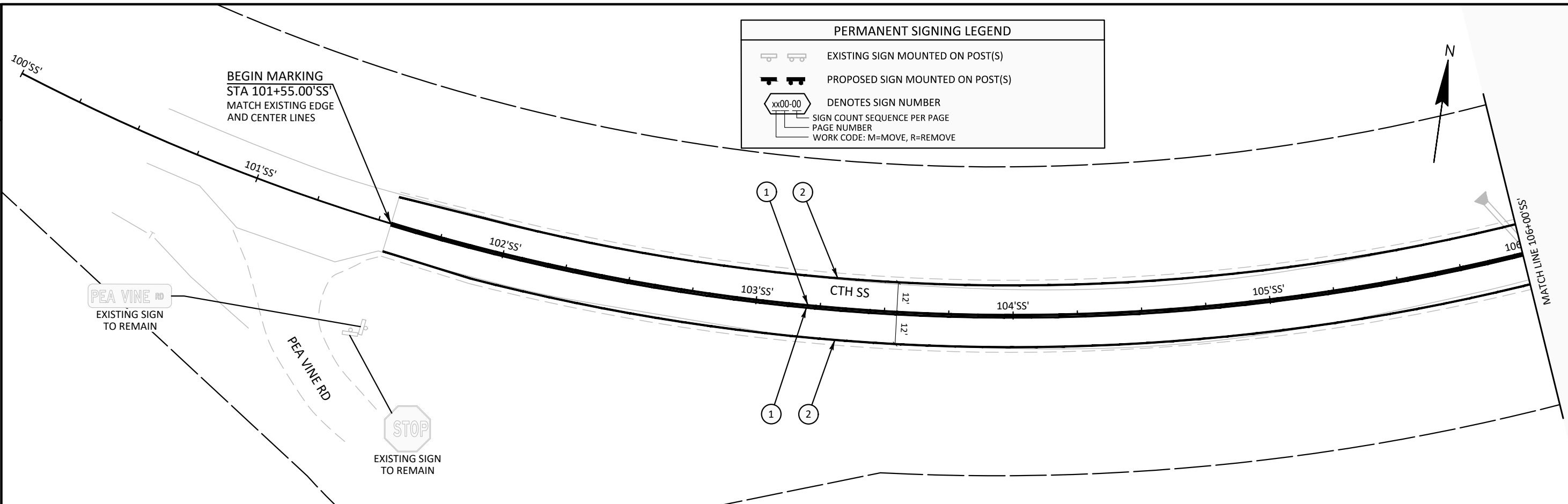

KEYNOTE LEGEND: PAVEMENT MARKING

- ① MARKING LINE PAINT 6-INCH (YELLOW)
- ② MARKING LINE PAINT 6-INCH (WHITE)

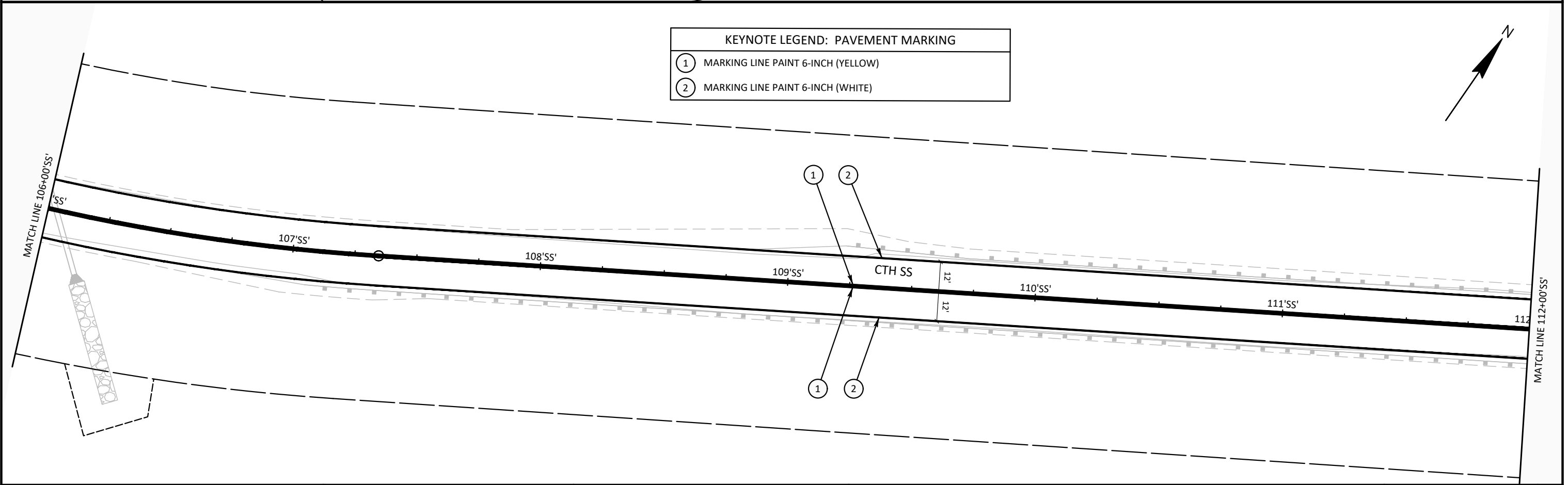

PERMANENT SIGNING LEGEND	
	EXISTING SIGN MOUNTED ON POST(S)
	PROPOSED SIGN MOUNTED ON POST(S)
	DENOTES SIGN NUMBER
	SIGN COUNT SEQUENCE PER PAGE
	PAGE NUMBER
	WORK CODE: M=MOVE, R=REMOVE

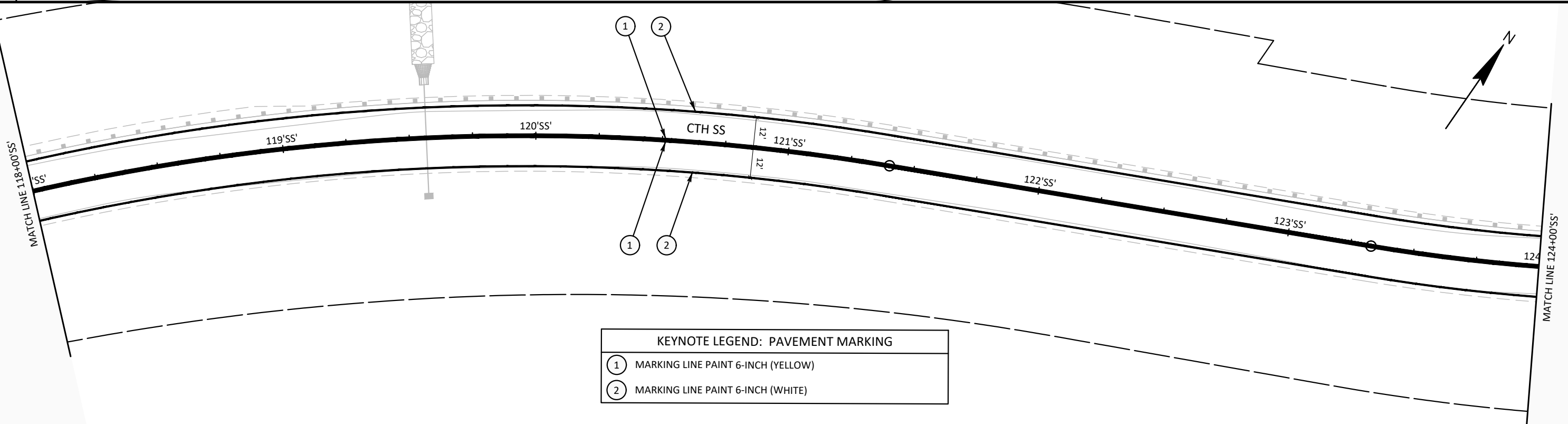
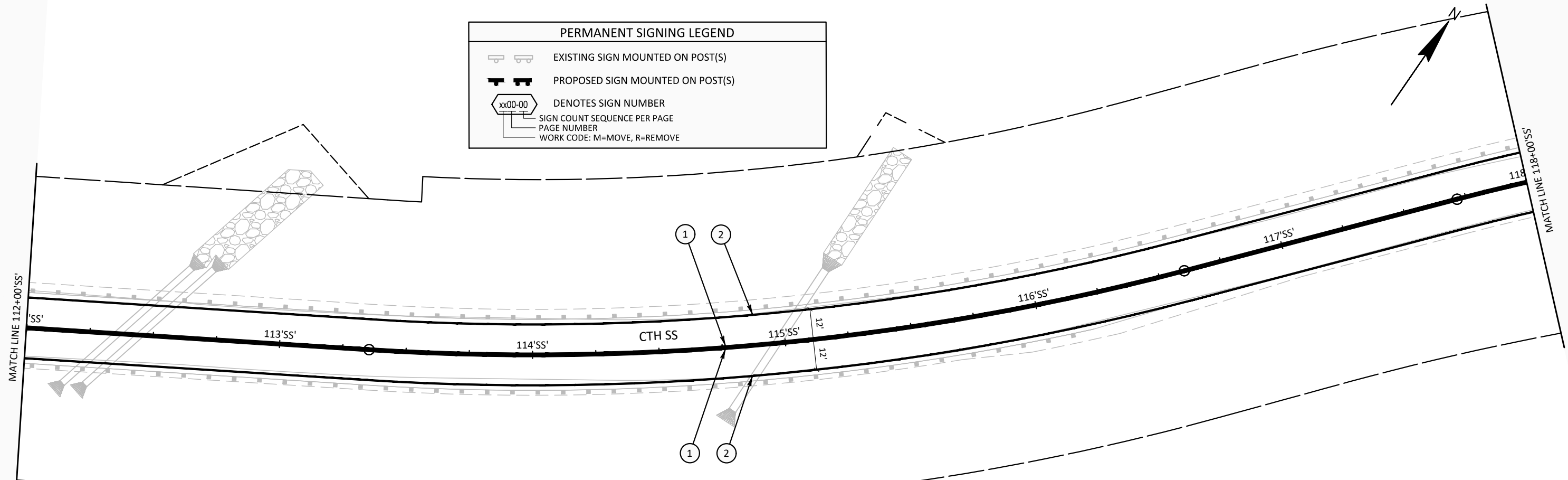

KEYNOTE LEGEND: PAVEMENT MARKING	
(1)	MARKING LINE PAINT 6-INCH (YELLOW)
(2)	MARKING LINE PAINT 6-INCH (WHITE)

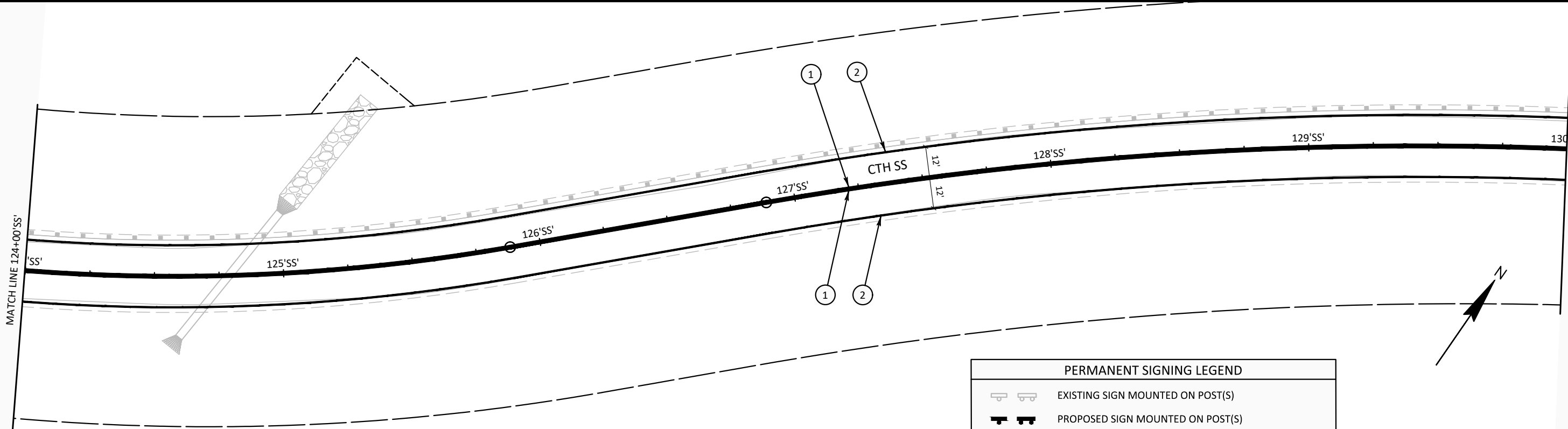

PERMANENT SIGNING LEGEND

- EXISTING SIGN MOUNTED ON POST(S)
- PROPOSED SIGN MOUNTED ON POST(S)
- DENOTES SIGN NUMBER
- SIGN COUNT SEQUENCE PER PAGE
- PAGE NUMBER
- WORK CODE: M=MOVE, R=REMOVE

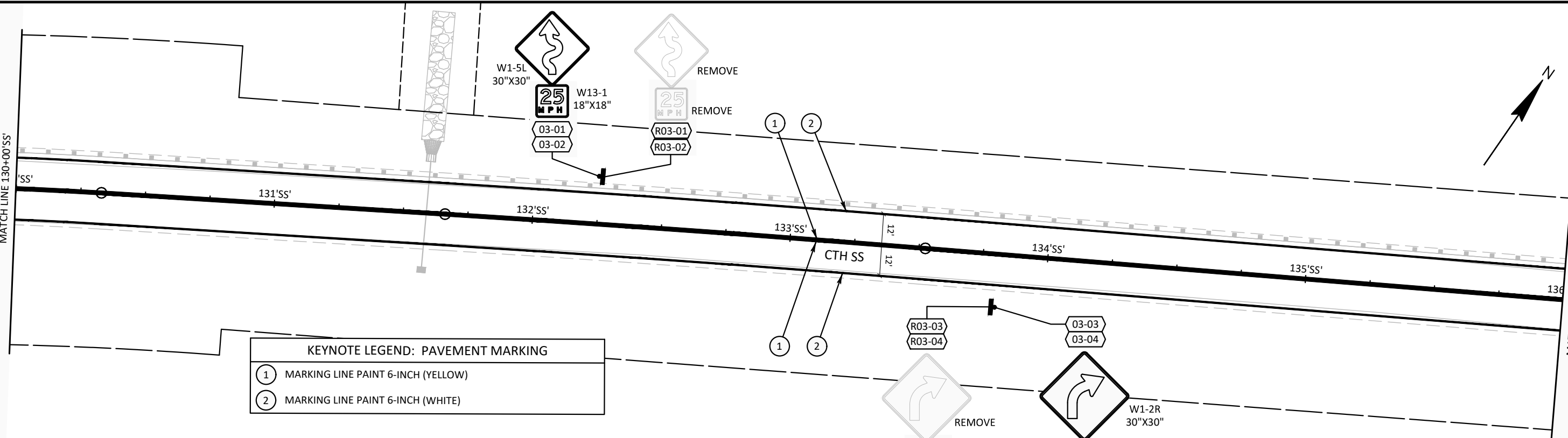

KEYNOTE LEGEND: PAVEMENT MARKING

- ① MARKING LINE PAINT 6-INCH (YELLOW)
- ② MARKING LINE PAINT 6-INCH (WHITE)

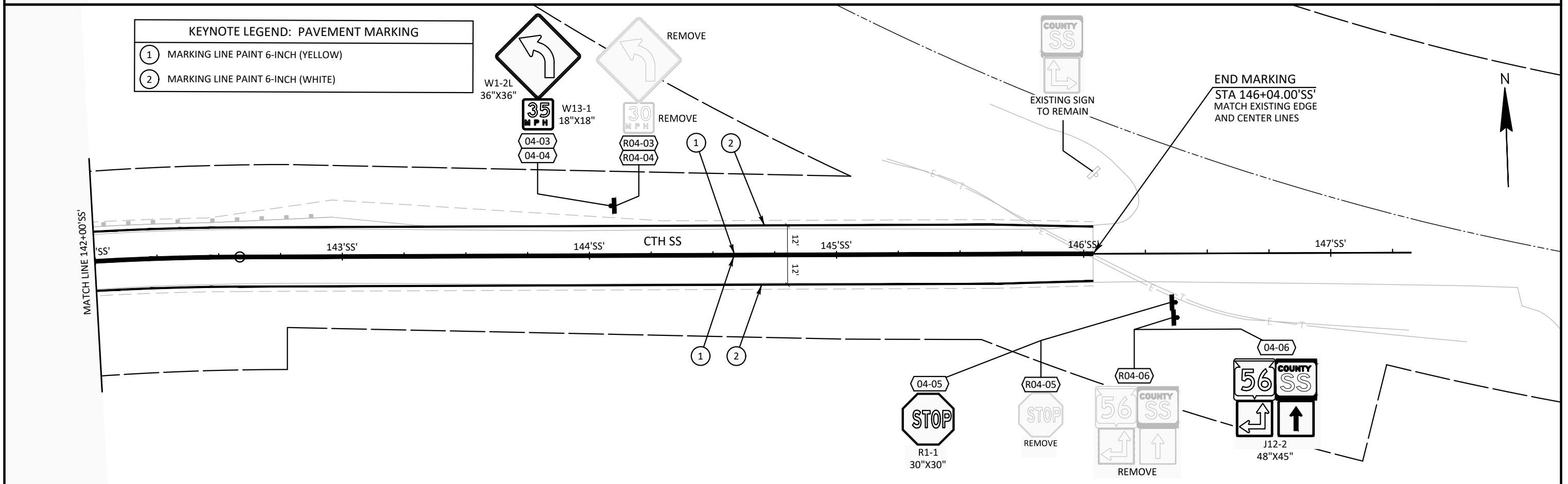
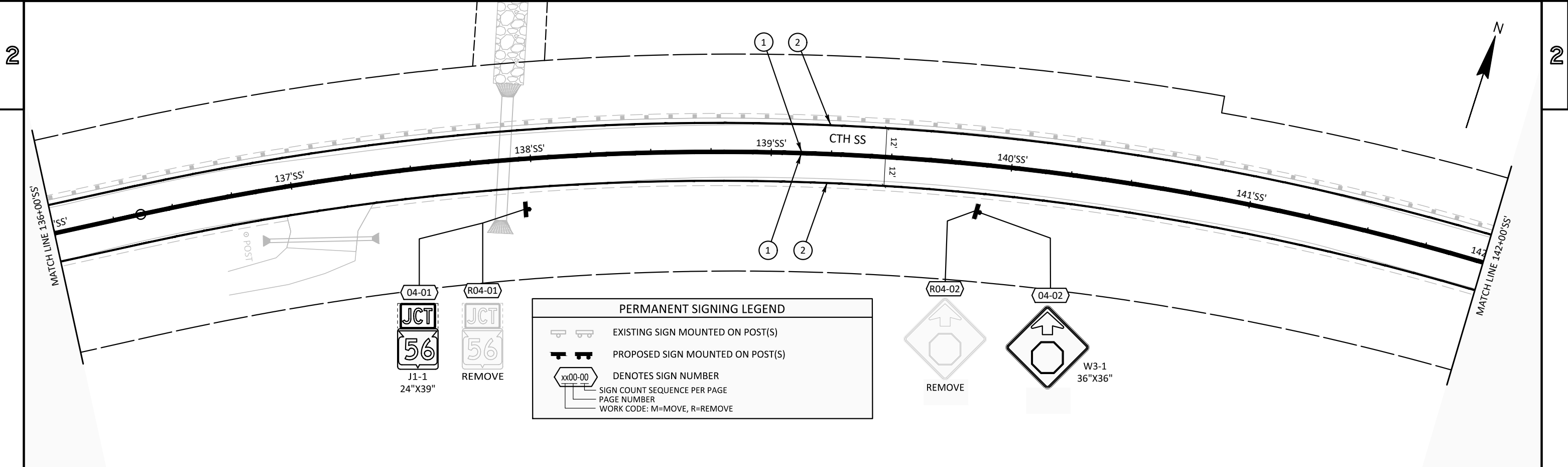

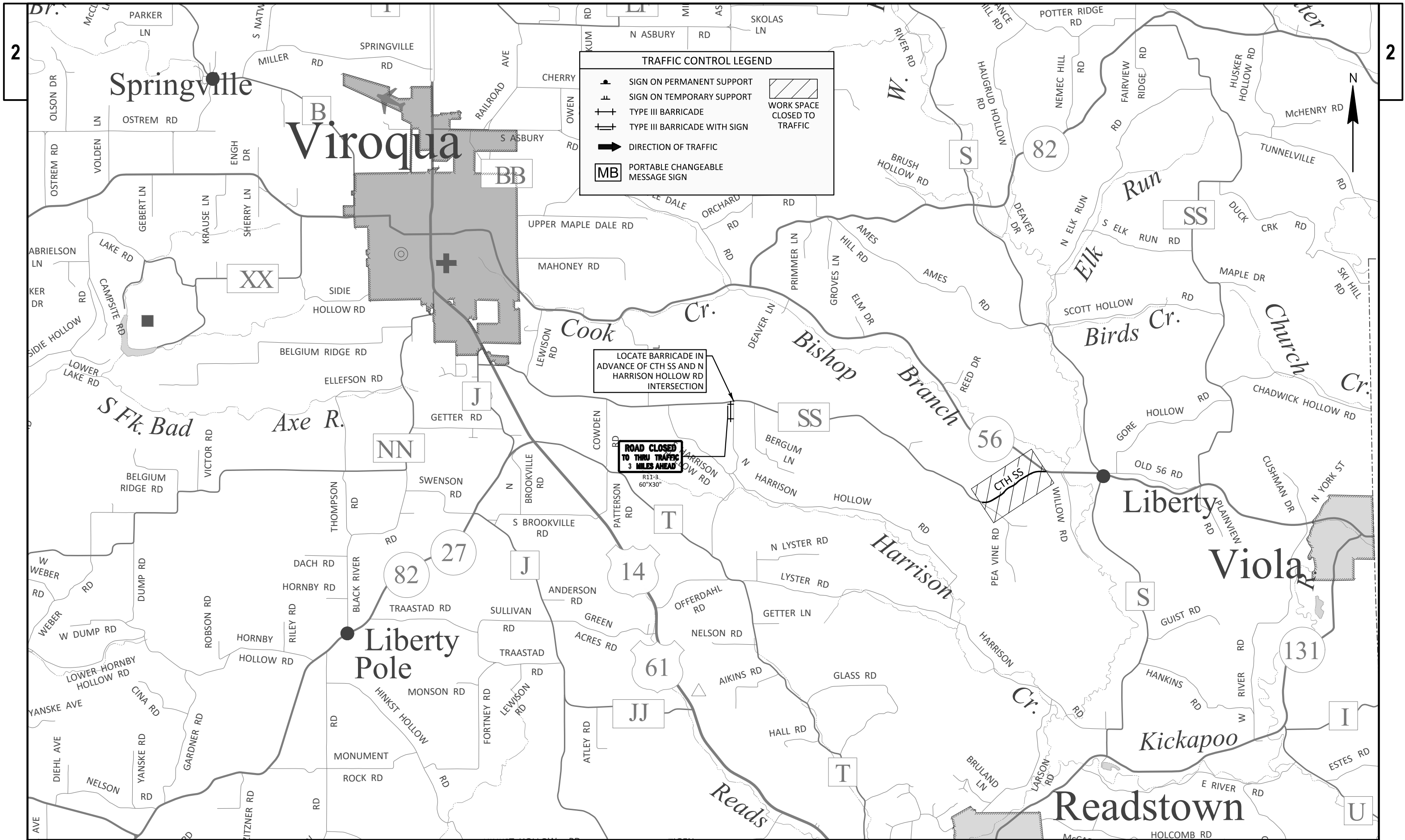

TRAFFIC CONTROL LEGEND

	SIGN ON PERMANENT SUPPORT		WORK SPACE CLOSED TO TRAFFIC
	SIGN ON TEMPORARY SUPPORT		
	TYPE III BARRICADE		
	TYPE III BARRICADE WITH SIGN		
	DIRECTION OF TRAFFIC		
	PORTABLE CHANGEABLE MESSAGE SIGN		

LOCATE BARRICADE IN ADVANCE OF CTH SS AND N HARRISON HOLLOW RD INTERSECTION

ROAD CLOSED TO THRU TRAFFIC 3 MILES AHEAD

DRAWING NOTES:

DETAILS OF CONSTRUCTION, MATERIALS AND WORKMANSHIP NOT SHOWN ON THIS DRAWING SHALL CONFORM TO THE PERTINENT REQUIREMENTS OF STANDARD DETAIL DRAWING "BARRICADES AND SIGNS FOR VARIOUS CLOSURES, DETAIL E."

TRAFFIC CONTROL LEGEND	
	SIGN ON PERMANENT SUPPORT
	SIGN ON TEMPORARY SUPPORT
	TYPE III BARRICADE
	TYPE III BARRICADE WITH SIGN
	DIRECTION OF TRAFFIC
	COVERING SIGNS TYPE II
	PORTABLE CHANGEABLE MESSAGE SIGN
	WORK SPACE CLOSED TO TRAFFIC

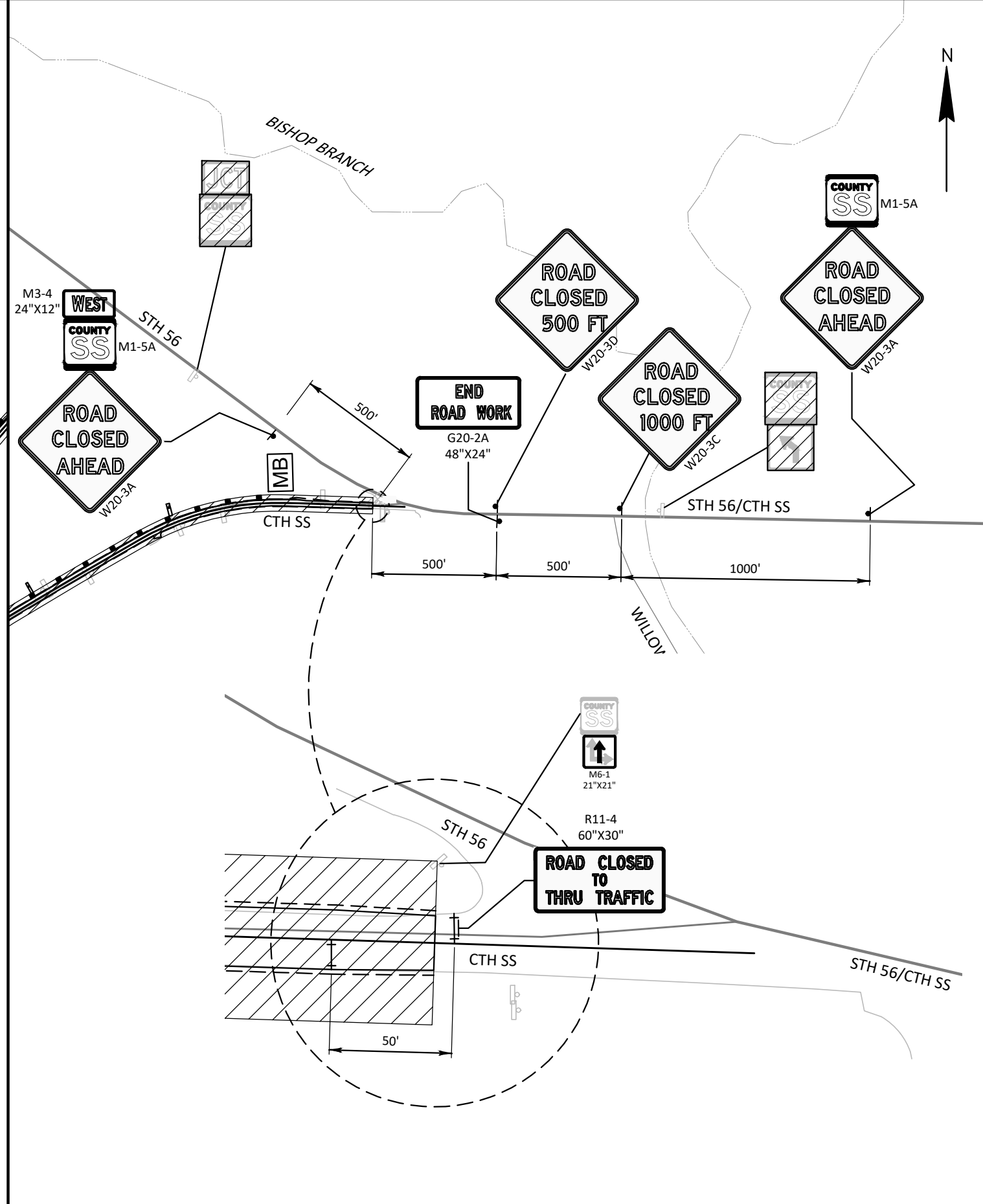
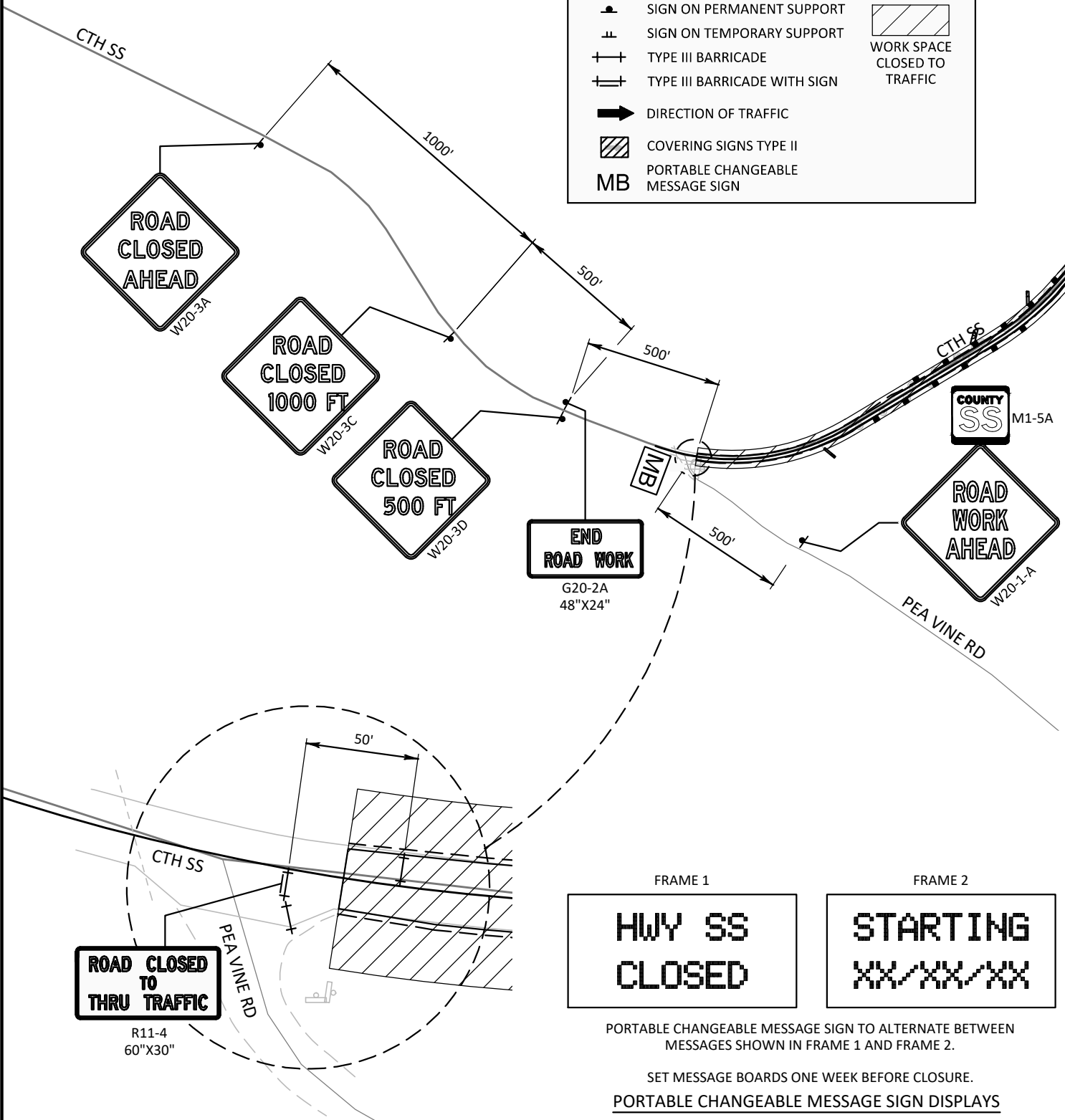

Estimate Of Quantities

5305-00-71

Line	Item	Item Description	Unit	Total	Qty
0002	201.0205	Grubbing	STA	38.000	38.000
0004	203.0100	Removing Small Pipe Culverts	EACH	9.000	9.000
0006	204.0110	Removing Asphaltic Surface	SY	56.000	56.000
0008	204.0165	Removing Guardrail	LF	2,512.000	2,512.000
0010	205.0100	Excavation Common	CY	26,392.000	26,392.000
0012	205.0200	Excavation Rock	CY	400.000	400.000
0014	209.1500	Backfill Granular Grade 1	TON	37,100.000	37,100.000
0016	213.0100	Finishing Roadway (project) 01. 5305-00-71	EACH	1.000	1.000
0018	305.0110	Base Aggregate Dense 3/4-Inch	TON	510.000	510.000
0020	305.0120	Base Aggregate Dense 1 1/4-Inch	TON	7,380.000	7,380.000
0022	455.0605	Tack Coat	GAL	642.000	642.000
0024	460.2000	Incentive Density HMA Pavement	DOL	1,850.000	1,850.000
0026	460.6223	HMA Pavement 3 MT 58-28 S	TON	1,620.000	1,620.000
0028	460.6224	HMA Pavement 4 MT 58-28 S	TON	1,260.000	1,260.000
0030	465.0120	Asphaltic Surface Driveways and Field Entrances	TON	9.000	9.000
0032	521.1018	Apron Endwalls for Culvert Pipe Steel 18-Inch	EACH	2.000	2.000
0034	521.1024	Apron Endwalls for Culvert Pipe Steel 24-Inch	EACH	2.000	2.000
0036	521.1030	Apron Endwalls for Culvert Pipe Steel 30-Inch	EACH	4.000	4.000
0038	521.1036	Apron Endwalls for Culvert Pipe Steel 36-Inch	EACH	4.000	4.000
0040	521.1257	Apron Endwalls for Pipe Arch Steel 57x38-Inch	EACH	2.000	2.000
0042	521.3118	Culvert Pipe Corrugated Steel 18-Inch	LF	48.000	48.000
0044	521.3124	Culvert Pipe Corrugated Steel 24-Inch	LF	53.000	53.000
0046	521.3130	Culvert Pipe Corrugated Steel 30-Inch	LF	136.000	136.000
0048	521.3136	Culvert Pipe Corrugated Steel 36-Inch	LF	128.000	128.000
0050	521.3757	Pipe Arch Corrugated Steel 57x38-Inch	LF	52.000	52.000
0052	522.1036	Apron Endwalls for Culvert Pipe Reinforced Concrete 36-Inch	EACH	2.000	2.000
0054	606.0300	Riprap Heavy	CY	252.000	252.000
0056	608.0336	Storm Sewer Pipe Reinforced Concrete Class III 36-Inch	LF	86.000	86.000
0058	611.0642	Inlet Covers Type MS	EACH	4.000	4.000
0060	611.3902	Inlets Median 2 Grate	EACH	2.000	2.000
0062	614.2300	MGS Guardrail 3	LF	927.000	927.000
0064	614.2330	MGS Guardrail 3 K	LF	3,160.000	3,160.000
0066	614.2610	MGS Guardrail Terminal EAT	EACH	4.000	4.000
0068	618.0100	Maintenance and Repair of Haul Roads (project) 01. 5305-00-71	EACH	1.000	1.000
0070	619.1000	Mobilization	EACH	1.000	1.000
0072	624.0100	Water	MGAL	450.000	450.000
0074	625.0500	Salvaged Topsoil	SY	7,540.000	7,540.000
0076	628.1504	Silt Fence	LF	4,110.000	4,110.000
0078	628.1520	Silt Fence Maintenance	LF	4,110.000	4,110.000
0080	628.1905	Mobilizations Erosion Control	EACH	5.000	5.000
0082	628.1910	Mobilizations Emergency Erosion Control	EACH	3.000	3.000
0084	628.2023	Erosion Mat Class II Type B	SY	4,200.000	4,200.000
0086	628.7005	Inlet Protection Type A	EACH	2.000	2.000
0088	628.7504	Temporary Ditch Checks	LF	590.000	590.000
0090	628.7515.S	Stone Ditch Checks	CY	330.000	330.000
0092	628.7555	Culvert Pipe Checks	EACH	37.000	37.000
0094	628.7560	Tracking Pads	EACH	2.000	2.000
0096	628.7570	Rock Bags	EACH	440.000	440.000
0098	629.0205	Fertilizer Type A	CWT	5.000	5.000
0100	630.0120	Seeding Mixture No. 20	LB	200.000	200.000

Estimate Of Quantities

5305-00-71

Line	Item	Item Description	Unit	Total	Qty
0102	630.0200	Seeding Temporary	LB	200.000	200.000
0104	630.0500	Seed Water	MGAL	180.000	180.000
0106	633.5200	Markers Culvert End	EACH	14.000	14.000
0108	634.0616	Posts Wood 4x6-Inch X 16-FT	EACH	2.000	2.000
0110	634.0618	Posts Wood 4x6-Inch X 18-FT	EACH	5.000	5.000
0112	637.2210	Signs Type II Reflective H	SF	26.680	26.680
0114	637.2230	Signs Type II Reflective F	SF	37.250	37.250
0116	638.2602	Removing Signs Type II	EACH	10.000	10.000
0118	638.3000	Removing Small Sign Supports	EACH	7.000	7.000
0120	642.5001	Field Office Type B	EACH	1.000	1.000
0122	643.0420	Traffic Control Barricades Type III	DAY	870.000	870.000
0124	643.0705	Traffic Control Warning Lights Type A	DAY	1,750.000	1,750.000
0126	643.0900	Traffic Control Signs	DAY	2,616.000	2,616.000
0128	643.0920	Traffic Control Covering Signs Type II	EACH	4.000	4.000
0130	643.1050	Traffic Control Signs PCMS	DAY	14.000	14.000
0132	643.5000	Traffic Control	EACH	1.000	1.000
0134	645.0120	Geotextile Type HR	SY	378.000	378.000
0136	645.0130	Geotextile Type R	SY	1,340.000	1,340.000
0138	645.0260	Geogrid Type SSR	SY	30,510.000	30,510.000
0140	646.2005	Marking Line Paint 6-Inch	LF	17,796.000	17,796.000
0142	650.4000	Construction Staking Storm Sewer	EACH	2.000	2.000
0144	650.4500	Construction Staking Subgrade	LF	4,449.000	4,449.000
0146	650.5000	Construction Staking Base	LF	4,449.000	4,449.000
0148	650.6000	Construction Staking Pipe Culverts	EACH	7.000	7.000
0150	650.9911	Construction Staking Supplemental Control (project) 01. 5305-00-71	EACH	1.000	1.000
0152	650.9920	Construction Staking Slope Stakes	LF	4,449.000	4,449.000
0154	690.0150	Sawing Asphalt	LF	73.000	73.000
0156	740.0440	Incentive IRI Ride	DOL	3,355.000	3,355.000
0158	ASP.1T0A	On-the-Job Training Apprentice at \$5.00/HR	HRS	400.000	400.000
0160	ASP.1TOG	On-the-Job Training Graduate at \$5.00/HR	HRS	300.000	300.000

GRUBBING

201.0205
GRUBBING

STATION	LOCATION	STA	REMARKS
104+00 - 110+00	RT	6	-
110+00 - 126+00	LT&RT	16	-
126+00 - 129+00	RT	3	-
129+00 - 133+00	LT&RT	4	-
133+00 - 136+00	RT	3	-
136+00 - 139+00	LT&RT	3	-
139+00 - 142+00	RT	3	-
PROJECT TOTALS		38	

EARTHWORK SUMMARY (PROJECT ID 5305-00-71)

FROM/TO STATION	LOCATION	205.0100 COMMON EXCAVATION (1)		SALVAGED / UNUSABLE PAVEMENT MATERIAL (4)	AVAILABLE MATERIAL (5)	205.0200 ROCK EXCAVATION (6)	REDUCED EBS IN FILL (7)	UNEXPANDED FILL	EXPANDED FILL (8)	MASS ORDINATE +/- (9)
		CUT (2)	EBS EXCAVATION (3)				FACTOR 0.80		FACTOR 1.25	
101+55 - 146+04	PROJECT	5,290	21,102	1,813	24,579		16,882	489	611	23,968
UNDISTRIBUTED						400				
PROJECT TOTAL		26,392				400				

NOTES:

- (1) COMMON EXCAVATION IS THE SUM OF THE CUT AND EBS EXCAVATION COLUMNS. ITEM NUMBER 205.0100
- (2) SALVAGED/UNUSABLE PAVEMENT MATERIAL IS INCLUDED IN CUT.
- (3) EBS EXCAVATION TO BE BACKFILLED WITH GRANULAR BACKFILL GRADE I.
- (4) SALVAGED/UNUSABLE PAVEMENT MATERIAL
- (5) AVAILABLE MATERIAL = CUT - SALVAGED/UNUSABLE PAVEMENT MATERIAL
- (6) ROCK EXCAVATION ITEM NUMBER 205.0200
- (7) REDUCED EBS IN FILL - EXCAVATED EBS MATERIAL IS USUABLE IN FILLS OUTSIDE THE 1:1 SLOPE. EBS IN FILL REDUCTION FACTOR = X.2X
- (8) EXPANDED FILL FACTOR = X.6X
- (9) THE MASS ORDINATE + OR - QTY CALCULATED FOR THE DIVISION. PLUS QUANTITY INDICATES AN EXCESS OF MATERIAL WITHIN THE DIVISION. MINUS INDICATES A SHORTAGE OF MATERIAL WITHIN THE DIVISION.

REMOVING SMALL PIPE CULVERTS

203.0100
REMOVING
SMALL PIPE
CULVERTS

STATION	LOCATION	CACTH	REMARKS
106+05	LT&RT	1	CMCP 18-INCH
111+85	LT	1	DRAIN BETWEEN GUARDRAIL POSTS, CMCP 24 INCH
112+41	LT&RT	1	CMCP 24-INCH
114+80	LT	1	DRAIN BETWEEN GUARDRAIL POSTS, CMCP 24-INCH
117+00	LT	1	DRAIN BETWEEN GUARDRAIL POSTS, CMCP 24-INCH
119+71	LT&RT	1	CMCP 18-INCH
131+56	LT&RT	1	CMCP 18-INCH
137+15	RT	1	CMCP 15-INCH
137+90	LT&RT	1	CMCP 43X64-INCH
PROJECT TOTALS		9	

REMOVING ASPHALTIC PAVEMENT

204.0110
REMOVING
ASPHALTIC SURFACE

STATION	LOCATION	SY	REMARKS
137+15	RT	56	ASPH PE
PROJECT TOTALS		56	

REMOVING GUARDRAIL

204.0165
REMOVING
GUARDRAIL

STATION	LOCATION	LF	REMARKS
107+20 - 111+59	RT	439	-
109+41 - 130+14	LT	2073	-
PROJECT TOTALS		2512	

3

BASE AGGREGATE ITEMS

Table with columns: STATION, LOCATION, TON, GRADE, DENSE, DENSE, WATER, GEOGRID, REMARKS. Includes project totals for various aggregate types.

ASPHALTIC ITEMS

Table with columns: STATION, LOCATION, GAL, TON, TON, ASPHALTIC SURFACE, REMARKS. Includes project totals for asphaltic items.

3

CULVERT PIPES

Table with columns: STATION, LOCATION, INLET, INLET, INLET, OUTLET, OUTLET, OUTLET, PIPE, APRON ENDWALLS, CORRUGATED STEEL, CORRUGATED STEEL, STEEL, STEEL, MARKERS. Includes project totals for culvert pipes.

*ADDITIONAL ITEMS SHOWN ELSEWHERE IN PLANS

STORM SEWER ITEMS

Table with columns: STATION, LOCATION, INLET, INLET, INLET, OUTLET, OUTLET, OUTLET, PIPE, APRON ENDWALLS, INLET, INLETS, MARKERS, REMARKS. Includes project totals for storm sewer items.

*ADDITIONAL ITEMS SHOWN ELSEWHERE IN PLANS

3

RIPRAP

STATION	LOCATION	606.0300	645.0120	REMARKS
		RIPRAP HEAVY CY	GEOTEXTILE TYPE HR SY	
106+20	RT	24	36	-
112+75	LT	53	79	-
115+30	LT	32	48	-
119+53	LT	32	48	-
125+10	LT	32	48	-
131+56	LT	32	48	-
137+95	LT	46	70	-
PROJECT TOTALS		252	378	

GUARDRAIL ITEMS

STATION	LOCATION	614.2300	614.2330	614.2610
		MGS GUARDRAIL 3 LF	MGS GUARDRAIL 3 K LF	MGS GUARDRAIL TERMINAL EAT EACH
107+06 - 116+20	RT	-	814	2
109+23 - 142+96	LT	927	2346	2
PROJECT TOTALS		927	3160	4

FINISHING ITEMS

STATION - STATION	625.0500	629.0205	630.0120	630.0200	630.0500
	SALVAGED TOPSOIL SY	FERTILIZER TYPE A CWT	SEEDING MIXTURE NO. 20 LB	SEEDING TEMPORARY LB	SEED WATER MGAL
ENTIRE PROJECT	6030	4	160	160	140
UNDISTRIBUTED QTY	1510	1	40	40	40
PROJECT TOTALS	7540	5	200	200	180

3

REMOVING SIGNS

SIGN #	SIGN MESSAGE	LOCATION	638.2602	638.3000
			REMOVING SIGNS TYPE II (EACH)	REMOVING SMALL SIGN SUPPORTS (EACH)
R03-01	CURVES IN ROADWAY	CTH SS	1	1
R03-02	25 MPH	CTH SS	1	-
R03-03	ROADWAY CURVES RIGHT	CTH SS	1	1
R03-04	25 MPH	CTH SS	1	-
R04-01	JCT STH 56	CTH SS	1	1
R04-02	STOP SIGN AHEAD	CTH SS	1	1
R04-03	ROADWAY CURVES LEFT	CTH SS	1	1
R04-04	30 MPH	CTH SS	1	-
R04-05	STOP SIGN	CTH SS	1	1
R04-06	STH 56 THRU LEFT / CTH SS THRU	CTH SS	1	1
PROJECT TOTALS			10	7

PERMANENT SIGNING

SIGN NO.	LT/RT	SIGN CODE	SIGN MESSAGE	SIZE W" X H"	637.2210	637.2230	634.0616	634.0618
					SIGNS TYPE II REFLECTIVE H (SF)	SIGNS TYPE II REFLECTIVE F (SF)	POSTS WOOD 4X6-INCH 16-FT (EACH)	POSTS WOOD 4X6-INCH 18-FT (EACH)
03-01	LT	W1-5L	CURVES IN ROADWAY	30"x30"	-	6.25	-	1
03-02	LT	W13-1	25 MPH	18"x18"	-	2.25	-	-
03-03	RT	W1-2R	ROADWAY CURVES RIGHT	30"x30"	-	6.25	-	1
03-04	RT	W13-1	30 MPH	18"x18"	-	2.25	-	-
04-01	RT	J1-1	JCT STH 56	24"x39"	6.50	-	1	-
04-02	RT	W3-1	STOP SIGN AHEAD	36"x36"	-	9.00	-	1
04-03	LT	W1-2L	ROADWAY CURVES LEFT	36"x36"	-	9.00	-	1
04-04	LT	W13-1	30 MPH	18"x18"	-	2.25	-	-
04-05	RT	R1-1	STOP SIGN	30"x30"	5.18	-	1	-
04-06	RT	J12-2	STH 56 THRU LEFT / CTH SS THRU	48"x45"	15.00	-	-	1
PROJECT TOTALS					26.68	37.25	2.00	5.00

EROSION CONTROL

STATION	LT/RT	628.1504	628.1520	628.2023	628.7005	628.7504	628.7515.S	628.7555	628.7560	628.7570	628.1905	628.1910	645.0130	REMARKS
		FENCE SILT LF	MAINTENANCE SILT FENCE LF	EROSION MAT CLASS II TYPE B SY	INLET PROTECTION TYPE A EACH	TEMPORARY DITCH CHECKS LF	STONE DITCH CHECKS CY	CULVERT PIPE CHECKS EACH	TRACKING PADS EACH	ROCK BAGS EACH	MOBILIZATIONS EROSION CONTROL EACH	MOBILIZATIONS EROSION CONTROL EACH	MOBILIZATIONS EROSION CONTROL EACH	
PROJET LENGTH		4110	4110	4200	2	470	260	37	2	350	5	3	1070	-
UNDISTRIBUTED		-	-	-	-	120	70	-	-	90	-	-	270	-
PROJECT TOTAL		4110	4110	4200	2	590	330	37	2	440	5	3	1340	

PROJECT NO: 5305-00-71

HWY: CTH SS

COUNTY: VERNON

MISCELLANEOUS QUANTITIES

SHEET

E

PAVEMENT MARKING

STATION	LOCATION	646.2005 MARKING LINE PAINT 6-INCH		REMARKS
		SOLID	SOLID	
		WHITE	YELLOW	
101+55 - 146+04	ML	8898	8898	
PROJECT TOTALS		17796		

TRAFFIC CONTROL

LOCATION	APPROX. SERVICE PERIOD	643.0420 TRAFFIC CONTROL BARRICADES TYPE III		643.0705 TRAFFIC CONTROL WARNING LIGHTS TYPE A		643.0900 TRAFFIC CONTROL SIGNS		**643.0920 TRAFFIC CONTROL COVERING SIGNS TYPE II		643.1050 TRAFFIC CONTROL SIGNS PCMS		NOTES
		DAYS	QTY.	DAYS	QTY.	DAYS	QTY.	DAYS	QTY.	DAYS	QTY.	
PRE-WARNING	7	0	0	0	0	0	0	0	2	14	PRE-WARN PRIOR TO CONSTRUCTION START	
ENTIRE PROJECT	121	6	726	12	1452	18	2178	4	0	0		
UNDISTRIBUTED			726		1452		2178			14		
PROJECT TOTALS			870		1750		2616		4	14		

**NUMBER OF CYCLES = 1

CONSTRUCTION STAKING

STATION	LOCATION	650.4000 CONSTRUCTION STAKING STORM SEWER		650.4500 CONSTRUCTION STAKING SUBGRADE		650.5000 CONSTRUCTION STAKING BASE		650.6000 CONSTRUCTION STAKING PIPE CULVERTS		650.9911 CONSTRUCTION STAKING SUPPLEMENTAL CONTROL		650.9920 CONSTRUCTION STAKING SLOPE STAKES	
		EACH	LF	LF	LF	EACH	EACH	LF					
101+55 - 146+04	LT&RT	2	4449	4449	7	1	4449						
PROJECT TOTALS		2	4449	4449	7	1	4449						

SAWING ASPHALT

STATION	LOCATION	690.0150 SAWING ASPHALT		REMARKS
		LF	LF	
101+55	ML	22		BEGIN PROJECT
136+94 - 137+23	RT	29		ASPH PE
146+04	ML	22		END PROJECT
PROJECT TOTALS		73		

CONVENTIONAL SYMBOLS

SECTION LINE		SECTION CORNER SYMBOL		R/W MONUMENT (TO BE SET)	
QUARTER LINE		SECTION CORNER MONUMENT		NON-MONUMENTED R/W POINT	
SIXTEENTH LINE		GEODETIC SURVEY MONUMENT		FOUND IRON PIN (1-INCH UNLESS NOTED)	
NEW REFERENCE LINE		SIXTEENTH CORNER MONUMENT		OFF-PREMISE SIGN	
NEW R/W LINE		SIGN		COMPENSABLE	
EXISTING R/W OR HE LINE		OFF-PREMISE SIGN		NON-COMPENSABLE	
PROPERTY LINE		PARALLEL OFFSETS			
LOT, TIE & OTHER MINOR LINES					
SLOPE INTERCEPT					
CORPORATE LIMITS					
UNDERGROUND FACILITY (COMMUNICATIONS, ELECTRIC, ETC)					
NEW R/W (FEE OR HE) (HATCHING VARIES BY OWNER)					
TEMPORARY LIMITED EASEMENT AREA					
EASEMENT AREA (PERMANENT LIMITED OR RESTRICTED DEVELOPMENT)					
TRANSMISSION STRUCTURES					
BUILDING TO BE REMOVED					
BRIDGE					
CULVERT					

CONVENTIONAL UTILITY SYMBOLS

WATER	
GAS	
TELEPHONE	
OVERHEAD TRANSMISSION LINES	
ELECTRIC	
CABLE TELEVISION	
FIBER OPTIC	
SANITARY SEWER	
STORM SEWER	
ELECTRIC TOWER	

CONVENTIONAL ABBREVIATIONS

ACCESS RIGHTS	AR	POINT OF COMPOUND CURVE	PCC
ACRES	AC	POINT OF INTERSECTION	PI
AHEAD	AH	PROPERTY LINE	PL
ALUMINUM	ALUM	RECORDED AS (100')	(100')
AND OTHERS	ET AL	REEL / IMAGE	R/I
BACK	BK	REFERENCE LINE	R/L
BLOCK	BLK	REMAINING	REM
CENTERLINE	C/L	RESTRICTIVE DEVELOPMENT EASEMENT	RDE
CERTIFIED SURVEY MAP	CSM		
CONCRETE	CONC	RIGHT	RT
COUNTY	CO	RIGHT OF WAY	R/W
COUNTY TRUNK HIGHWAY	CTH	SECTION	SEC
DISTANCE	DIST	SEPTIC VENT	SEPV
CORNER	COR	SQUARE FEET	SF
DOCUMENT NUMBER	DOC	STATE TRUNK HIGHWAY	STH
EASEMENT	EASE	STATION	STA
EXISTING	EX	TELEPHONE PEDESTAL	TP
GAS VALVE	GV	TEMPORARY LIMITED EASEMENT	TLE
GRID NORTH	GN		
HIGHWAY EASEMENT	HE	TRANSPORTATION PROJECT PLAT	TTP
IDENTIFICATION	ID	UNITED STATES HIGHWAY	USH
LAND CONTRACT	LC	VOLUME	V
LEFT	LT		
MONUMENT	MON		
NATIONAL GEODETIC SURVEY NUMBER	NGS		
OUTLOT	OL		
PAGE	P		
POINT OF TANGENCY	PT		
PERMANENT LIMITED EASEMENT	PLE		
POINT OF BEGINNING	POB		
POINT OF CURVATURE	PC		

CURVE DATA ABBREVIATIONS

LONG CHORD	LCH
LONG CHORD BEARING	LCB
RADIUS	R
DEGREE OF CURVE	D
CENTRAL ANGLE	Δ/DELTA
LENGTH OF CURVE	L
TANGENT	T
DIRECTION AHEAD	DA
DIRECTION BACK	DB

NOTES:

POSITIONS SHOWN ON THIS PLAT ARE WISCONSIN COORDINATE REFERENCE SYSTEM COORDINATES (WISCRS), VERNON COUNTY, NAD83 (2011) IN US SURVEY FEET. VALUES SHOWN ARE GRID COORDINATES, GRID BEARINGS, AND GRID DISTANCES. GRID DISTANCES MAY BE USED AS GROUND DISTANCES.

ALL NEW RIGHT-OF-WAY MONUMENTS WILL BE TYPE 2 (TYPICALLY 3/4" X 24" IRON REBARS), UNLESS OTHERWISE NOTED, AND WILL BE PLACED PRIOR TO THE COMPLETION OF THE PROJECT.

ALL RIGHT-OF-WAY LINES DEPICTED IN THE NON-ACQUISITION AREAS ARE INTENDED TO RE-ESTABLISH EXISTING RIGHT-OF-WAY LINES AS DETERMINED FROM PREVIOUS PROJECTS, OTHER RECORDED DOCUMENTS, OR FROM CENTERLINE OF EXISTING PAVEMENTS.

RIGHT-OF-WAY BOUNDARIES ARE DEFINED WITH COURSES OF THE PERIMETER OF THE HIGHWAY LANDS REFERENCED TO THE U.S. PUBLIC LAND SURVEY SYSTEM OR OTHER "SURVEYS OF PUBLIC RECORD".

DIMENSIONING FOR THE NEW MEASURED RIGHT-OF-WAY IS ALONG AND PERPENDICULAR TO THE NEW REFERENCE LINES.

A PERMANENT LIMITED EASEMENT (PLE) IS A RIGHT FOR CONSTRUCTION AND MAINTENANCE PURPOSES, AS DEFINED HEREIN, INCLUDING THE RIGHT TO OPERATE NECESSARY EQUIPMENT THEREON AND THE RIGHT OF INGRESS AND EGRESS, AS LONG AS REQUIRED FOR SUCH PUBLIC PURPOSE, INCLUDING THE RIGHT TO PRESERVE, PROTECT, REMOVE, OR PLANT THEREON ANY VEGETATION THAT THE HIGHWAY AUTHORITIES MAY DEEM DESIRABLE, BUT WITHOUT PREJUDICE TO THE OWNER'S RIGHTS TO MAKE OR CONSTRUCT IMPROVEMENTS ON SAID LANDS OR TO FLATTEN THE SLOPES, PROVIDING SAID ACTIVITIES WILL NOT IMPAIR OR OTHERWISE ADVERSELY AFFECT THE HIGHWAY FACILITIES.

PROPERTY LINES SHOWN ON THIS PLAT ARE DRAWN FROM DATA DERIVED FROM MAPS AND DOCUMENTS OF PUBLIC RECORD AND/OR EXISTING OCCUPATIONAL LINES. THIS PLAT MAY NOT BE A TRUE REPRESENTATION OF EXISTING PROPERTY LINES, EXCLUDING RIGHT-OF-WAY, AND SHOULD NOT BE USED AS A SUBSTITUTE FOR AN ACCURATE FIELD SURVEY.

FOR THE CURRENT ACCESS/DRIVEWAY INFORMATION, CONTACT THE VERNON COUNTY HIGHWAY DEPARTMENT.

PARCEL AND UTILITY IDENTIFICATION NUMBERS MAY NOT POINT TO ALL AREAS OF ACQUISITION, AS NOTED ON THE DETAIL PAGES.

INFORMATION FOR THE BASIS OF EXISTING HIGHWAY RIGHT-OF-WAY POINTS OF REFERENCE AND ACCESS CONTROL ARE LISTED ON THE DETAIL PAGES.

BEGIN RELOCATION

STA 104+00.00

Y = 132931.999
X = 736107.298

869.848 FEET NORTH AND
2834.418 FEET WEST OF THE
SOUTHEAST CORNER OF
SECTION 17, T12N, R3W

END RELOCATION

STA 140+00.00

Y = 134807.125
X = 739132.470

164.565 FEET NORTH AND
187.925 FEET EAST OF THE
WEST QUARTER CORNER
OF SECTION 16, T12N, R3W

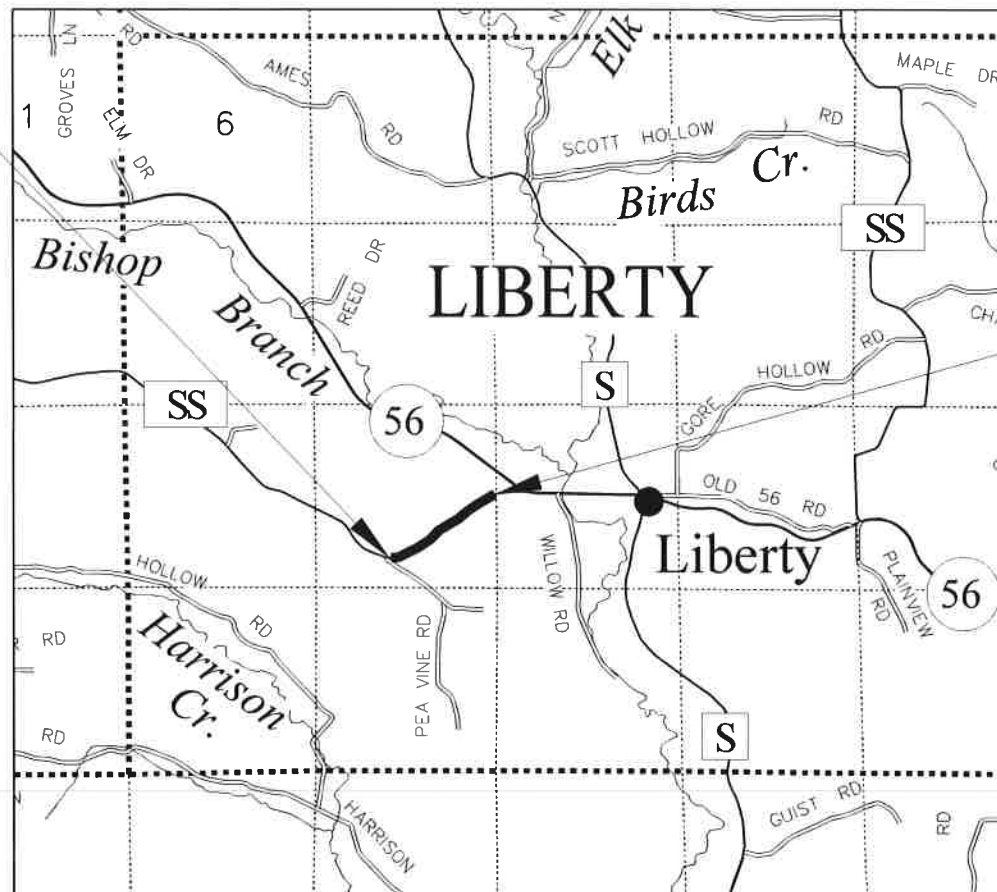

R 3 W

LAYOUT

SCALE 0 1.0 MILES

TOTAL NET LENGTH OF CENTERLINE = 0.682 MILES

THIS PLAT IS A GRAPHIC REPRESENTATION AND IS FOR REFERENCE PURPOSES ONLY. DEEDS MUST BE CHECKED TO DETERMINE PROPERTY BOUNDARIES AND ACCESS RIGHTS.

R/W PROJECT NUMBER 5295-00-01	SHEET NUMBER 4.01	TOTAL SHEETS 4
FEDERAL PROJECT NUMBER 5295-00-01	PLAT OF RIGHT OF WAY REQUIRED FOR TOWN OF LIBERTY - STH 56 (CTH SS) PEA VINE ROAD TO STH 56	
CTH SS	VERNON COUNTY	
CONSTRUCTION PROJECT NUMBER 5295-00-01		

Original Plat Prepared by



Jason L. Cance 7-17-2023
(Signature) (Date)

REVISION DATE

ACCEPTED FOR

COUNTY OF VERNON

DATE: 7-18-23 *Phil Hewitt*
(Signature)

OWNER'S NAMES ARE SHOWN FOR REFERENCE PURPOSES ONLY AND ARE SUBJECT TO CHANGE PRIOR TO TRANSFER OF LAND INTERESTS TO THE COUNTY.

SCHEDULE OF LANDS & INTERESTS REQUIRED

PARCEL NUMBER	SHEET NUMBER	OWNER(S)	INTEREST REQUIRED	R/W ACRES REQUIRED			PLE ACRES
				NEW	EXISTING	TOTAL	
1	4.03	STEVEN A. FOSSUM REVOCABLE TRUST	PLE	-	-	-	0.02
-	-	-	-	-	-	-	-
3	4.03	DANIEL R. & SHEILA M. KANIS	PLE	-	-	-	0.06
4	4.04	RICHARD A. & JADE C. OLIVER	PLE	-	-	-	0.07
-	-	-	-	-	-	-	-
50	4.03	WISCONSIN TELEPHONE COMPANY	RELEASE OF RIGHTS				

4

4

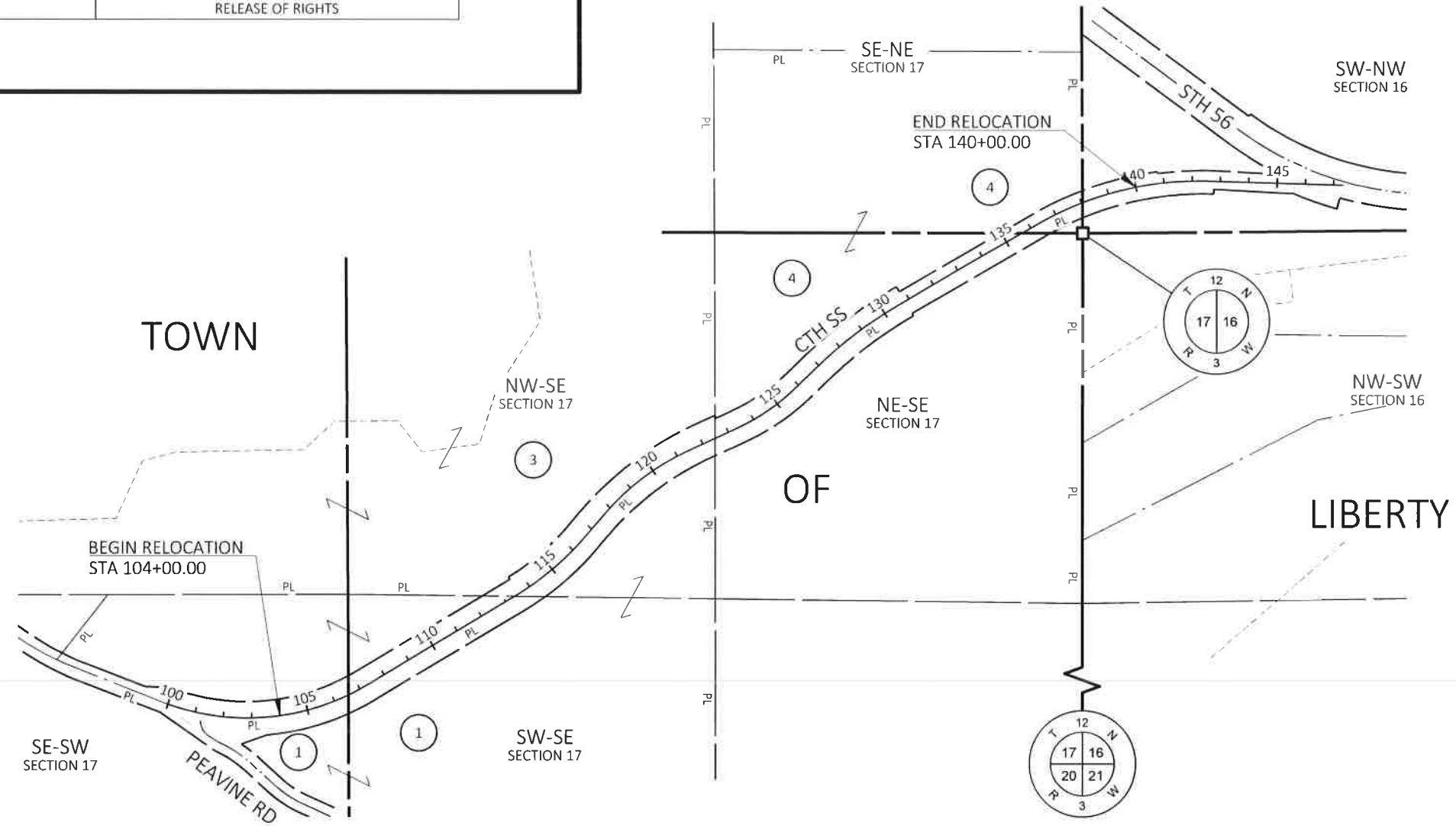

REVISION DATE	DATE	SCALE, FEET	HWY: CTH SS	R/W PROJECT NUMBER 5295-00-01	PLAT SHEET 4.02
	GRID FACTOR	0 N/A	COUNTY: VERNON	CONSTRUCTION PROJECT NUMBER 5295-00-01	PS&E SHEET

E

RECOVERED MONUMENTS			
POINT	Y	X	DESCRIPTION
107	133947.907	737644.359	3/4" REBAR
108	133353.788	736872.337	3/4" REBAR (HIT)

CURVE TABLE				
CURVE	RADIUS	ARC LENGTH	LONG CHORD BEARING	LONG CHORD
60-20	830.00'	80.32'	S 61° 49' 04" W	80.29'
203-200	878.60'	36.50'	N 65° 09' 43" E	36.50'
61-22	1015.00'	240.41'	N 52° 15' 36" E	239.85'
220-222	885.00'	35.26'	N 46° 06' 06" E	35.26'
22-62	1015.00'	84.35'	N 43° 05' 38" E	84.32'
63-23	875.00'	171.28'	N 46° 19' 16" E	171.01'
233-230	1216.00'	30.14'	S 52° 28' 03" W	30.14'

PLE - COURSE TABLE		
COURSE	BEARING	DISTANCE
41-60	N 68° 45' 53" W	2705.96'
60-20	SEE CURVE TABLE	
20-200	S 25° 24' 36" E	59.56'
200-201	S 25° 24' 36" E	15.44'
201-202	S 38° 55' 31" W	26.96'
202-203	N 49° 20' 23" W	30.06'
203-200	SEE CURVE TABLE	
60-21	N 59° 02' 43" E	516.68'
21-210	N 30° 57' 17" W	59.71'
210-211	N 32° 13' 55" E	60.51'
211-213	S 76° 08' 19" E	39.08'
213-210	S 59° 13' 25" W	81.73'
60-61	N 59° 02' 43" E	602.27'
21-61	N 59° 02' 43" E	85.59'
61-22	SEE CURVE TABLE	
22-222	N 44° 31' 32" W	69.64'
222-221	S 81° 59' 23" W	26.22'
221-220	S 01° 31' 57" E	20.80'
220-222	SEE CURVE TABLE	
22-62	SEE CURVE TABLE	
62-63	N 40° 42' 48" E	111.37'
63-23	SEE CURVE TABLE	
23-230	N 38° 04' 15" W	66.64'
230-231	N 38° 04' 15" W	22.36'
231-232	N 52° 50' 45" E	30.85'
232-233	S 36° 14' 15" E	22.16'
233-230	SEE CURVE TABLE	

PLE AND COMPUTED POINTS STATION & OFFSET TABLE		
POINT	STATION	OFFSET
20	106+53.00	0.00'
21	112+50.00	0.00'
22	115+76.00	0.00'
23	119+43.00	0.00'
60	107+33.32	0.00'
61	113+35.59	0.00'
62	116+60.35	0.00'
63	117+71.72	0.00'
64	121+40.44	0.00'
65	123+33.20	0.00'
200	106+53.00	59.56' RT
201	106+53.00	75.00' RT
202	106+31.00	87.00' RT
203	106+18.95	59.95' RT
210	112+50.00	59.71' LT
211	113+04.00	87.00' LT
213	113+31.73	59.45' LT
220	115+38.15	69.37' LT
221	115+53.00	85.00' LT
222	115+76.00	69.64' LT
230	119+43.00	66.64' LT
231	119+43.00	89.00' LT
232	119+71.00	89.00' LT
233	119+71.00	66.84' LT

ROAD NAME	BASIS OF EXISTING R/W	YEAR
CTH SS	DOC 239520, V. 171, P. 600 DOC. 239466, V. 171, P. 521	1968
LTH SS	WI STATUTE 82.3(2)	

PER DOCUMENTS REFERENCED ABOVE IT APPEARS THERE WAS RIGHT-OF-WAY ACQUISITION IN 1968 THAT IS NOT REFLECTED IN RECENT MAPS AND SURVEYS. THEREFORE PROPERTY CORNERS FOUND ALONG THIS RIGHT-OF-WAY PLAT WERE NOT ACCEPTED AND THE EXISTING RIGHT-OF-WAY IS SHOWN AS PURCHASED IN 1968.

SECTION LINE - COURSE TABLE		
COURSE	BEARING	DISTANCE
41-42	N 00° 03' 46" E	2580.41'

PI STA = 103+92.54
Y = 132840.341
X = 736082.864
DELTA = 50°37'20" LT
D = 6°54'11"
T = 392.54'
L = 733.32'
R = 830.00'
PC STA = 100+00.00
PT STA = 107+33.32

PI STA = 114+99.37
Y = 133436.269
X = 737076.432
DELTA = 18°19'55" LT
D = 5°38'42"
T = 163.78'
L = 324.75'
R = 1015.00'
PC STA = 113+35.59
PT STA = 116+60.35

PI STA = 119+58.86
Y = 133786.676
X = 737377.970
DELTA = 24°08'40" RT
D = 6°32'53"
T = 187.14'
L = 368.73'
R = 875.00'
PC STA = 117+71.72
PT STA = 121+40.44

FOUND BRASS CAP
Y= 134642.560
X= 738944.545

FOUND BRASS CAP
Y= 132062.151
X= 738941.716

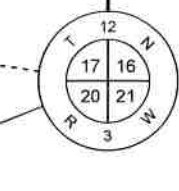
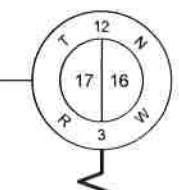

4

4

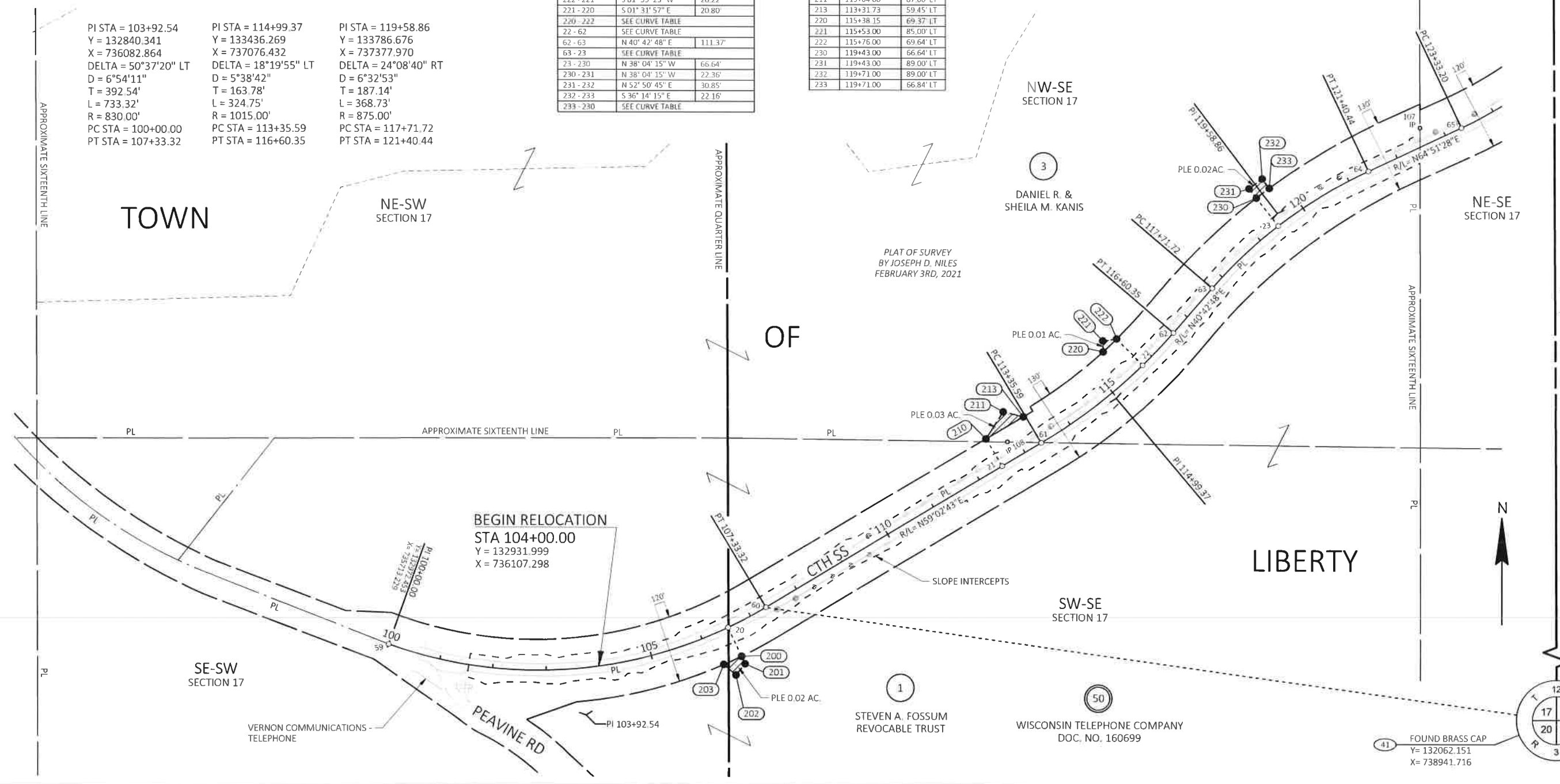

REVISION DATE	DATE	SCALE, FEET	HWY: CTH SS	R/W PROJECT NUMBER 5295-00-01	PLAT SHEET 4.03
	GRID FACTOR N/A	0 100 200	COUNTY: VERNON	CONSTRUCTION PROJECT NUMBER 5295-00-01	PS&E SHEET

ROAD NAME	BASIS OF EXISTING R/W	YEAR
CTH 55	DOC. 239898, V. 172, P. 485	1968
CTH 55	WI STATUTE 82.31(2)	

PER DOCUMENTS REFERENCED ABOVE IT APPEARS THERE WAS RIGHT-OF-WAY ACQUISITION IN 1968 THAT IS NOT REFLECTED IN RECENT MAPS AND SURVEYS. THEREFORE PROPERTY CORNERS FOUND ALONG THIS RIGHT-OF-WAY PLAT WERE NOT ACCEPTED AND THE EXISTING RIGHT-OF-WAY IS SHOWN AS PURCHASED IN 1968.

CURVE	RADIUS	ARC LENGTH	LONG CHORD BEARING	LONG CHORD
71 - 26	1120.00'	143.05'	N 63° 40' 15" E	142.96'
263 - 260	1186.00'	29.92'	S 67° 49' 06" W	29.92'
70 - 69	10000.00'	186.28'	S 59° 28' 41" W	186.28'
68 - 67	1465.00'	344.10'	S 52° 12' 56" W	343.31'
66 - 24	755.00'	29.45'	S 46° 36' 16" W	29.45'
242 - 240	758.60'	40.02'	S 50° 54' 25" W	40.02'

COURSE	BEARING	DISTANCE
42 - 71	N 76° 17' 50" W	154.98'
71 - 26	SEE CURVE TABLE	
26 - 260	N 22° 40' 12" W	40.01'
260 - 261	N 31° 41' 53" W	53.42'
261 - 262	N 75° 31' 59" E	28.60'
262 - 263	S 34° 50' 56" E	49.40'
263 - 260	SEE CURVE TABLE	
71 - 70	S 60° 00' 43" W	283.97'
70 - 69	SEE CURVE TABLE	
69 - 25	S 58° 56' 40" W	20.33'
25 - 250	N 31° 03' 20" W	39.31'
250 - 251	N 31° 03' 20" W	49.69'
251 - 252	N 58° 57' 07" E	29.08'
252 - 253	S 31° 00' 21" E	50.08'
253 - 250	S 59° 43' 43" W	29.04'
25 - 68	S 58° 56' 40" W	112.87'
68 - 67	SEE CURVE TABLE	
67 - 66	S 45° 29' 12" W	100.57'
66 - 24	SEE CURVE TABLE	
24 - 242	N 42° 16' 41" W	59.72'
242 - 240	SEE CURVE TABLE	
240 - 241	N 04° 08' 08" E	28.05'
241 - 242	S 84° 36' 07" E	29.16'

PI STA = 124+62.06 Y = 134002.828 X = 737838.523 DELTA = 19°22'16" LT D = 7°35'20" T = 128.86' L = 255.26' R = 755.00' PC STA = 123+33.20 PT STA = 125+88.45	PI STA = 128+61.88 Y = 134284.856 X = 738125.383 DELTA = 13°27'28" RT D = 3°54'40" T = 172.85' L = 344.10' R = 1465.00' PC STA = 126+89.03 PT STA = 130+33.13	PI STA = 132+59.47 Y = 134490.785 X = 738467.356 DELTA = 1°04'02" RT D = 0°34'23" T = 93.14' L = 186.28' R = 10000.00' PC STA = 131+66.33 PT STA = 133+52.61	PI STA = 139+55.87 Y = 134838.863 X = 739070.532 DELTA = 31°49'27" RT D = 5°06'57" T = 319.30' L = 622.09' R = 1120.00' PC STA = 136+36.58 PT STA = 142+58.67
---	--	---	--

4

4

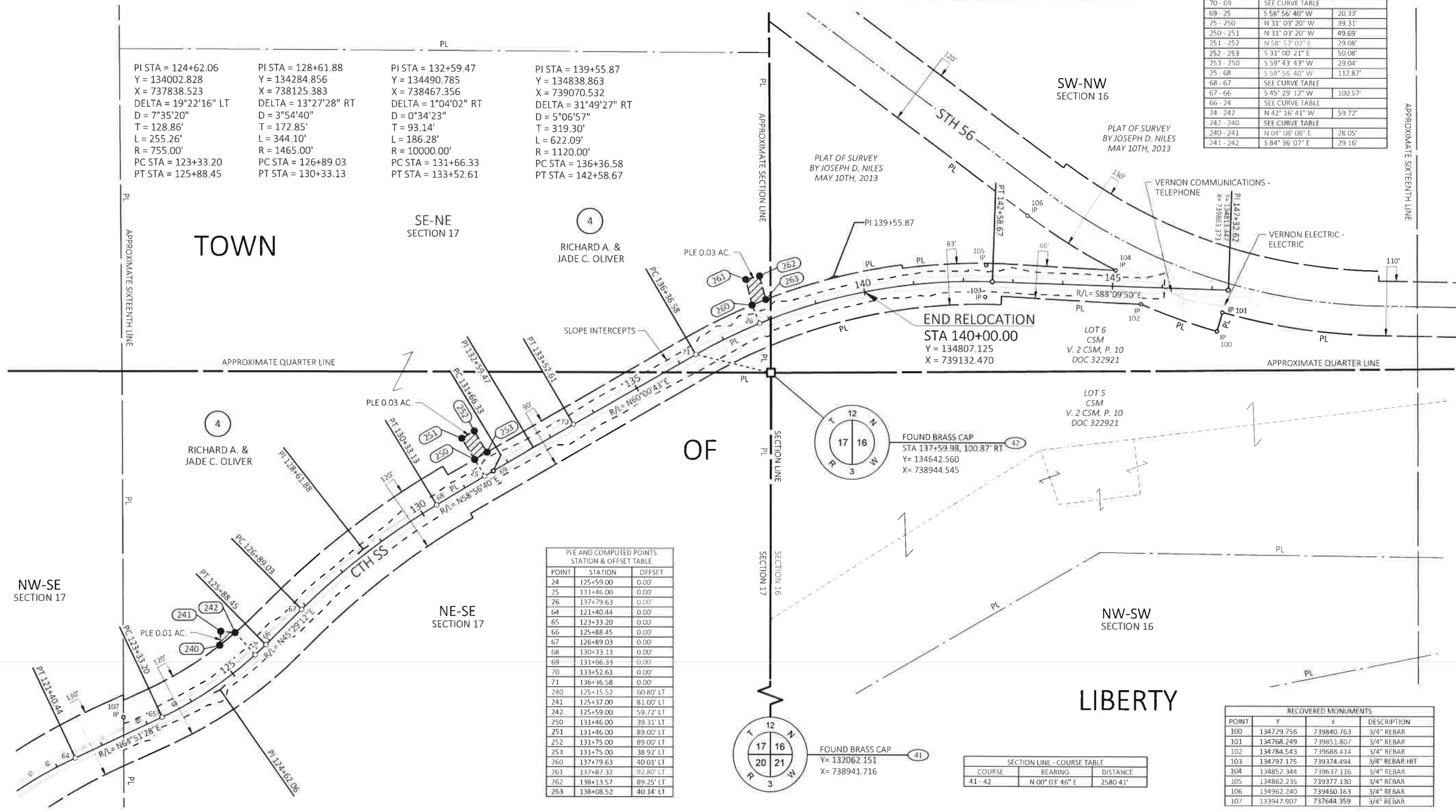

POINT	STATION	OFFSET
24	125+59.00	0.00'
25	131+46.00	0.00'
26	137+79.63	0.00'
64	121+40.44	0.00'
65	123+33.20	0.00'
66	125+88.45	0.00'
67	126+89.03	0.00'
68	130+33.13	0.00'
69	131+66.33	0.00'
70	133+52.61	0.00'
71	136+36.58	0.00'
240	125+15.52	60.80' LT
241	125+37.00	81.00' LT
242	125+59.00	59.72' LT
250	131+46.00	39.31' LT
251	131+46.00	89.00' LT
252	131+75.00	89.00' LT
253	131+75.00	38.92' LT
260	137+79.63	40.01' LT
261	137+87.32	92.80' LT
262	138+13.57	89.25' LT
263	138+08.52	40.14' LT

COURSE	BEARING	DISTANCE
41 - 42	N 00° 03' 46" E	2580.41'

POINT	Y	X	DESCRIPTION
100	134729.756	739840.763	3/4" REBAR
101	134768.249	739851.807	3/4" REBAR
102	134784.543	739688.414	3/4" REBAR
103	134797.175	739374.494	3/4" REBAR HIT
104	134852.344	739637.116	3/4" REBAR
105	134862.235	739377.130	3/4" REBAR
106	134952.240	739460.163	3/4" REBAR
107	133947.907	737644.359	3/4" REBAR

REVISION DATE	DATE	SCALE, FEET	HWY: CTH 55	R/W PROJECT NUMBER 5295-00-01	PLAT SHEET 4.04
	GRID FACTOR N/A	0 100 200	COUNTY: VERNON	CONSTRUCTION PROJECT NUMBER 5295-00-01	PS&E SHEET

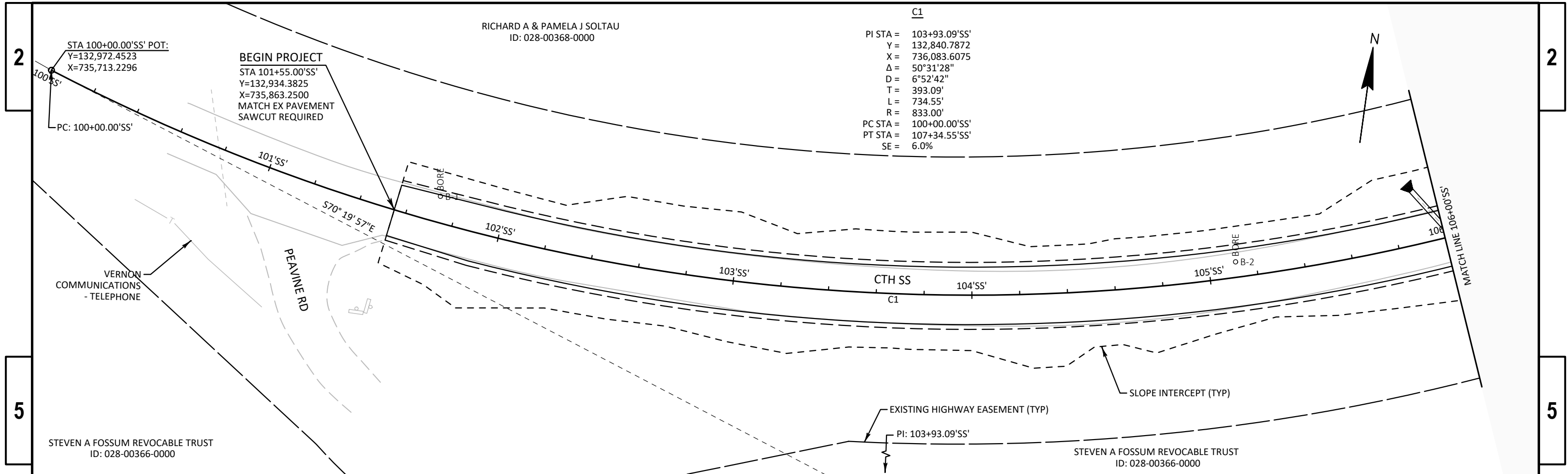

C1
 PI STA = 103+93.09'SS'
 Y = 132,840.7872
 X = 736,083.6075
 Δ = 50°31'28"
 D = 6°52'42"
 T = 393.09'
 L = 734.55'
 R = 833.00'
 PC STA = 100+00.00'SS'
 PT STA = 107+34.55'SS'
 SE = 6.0%

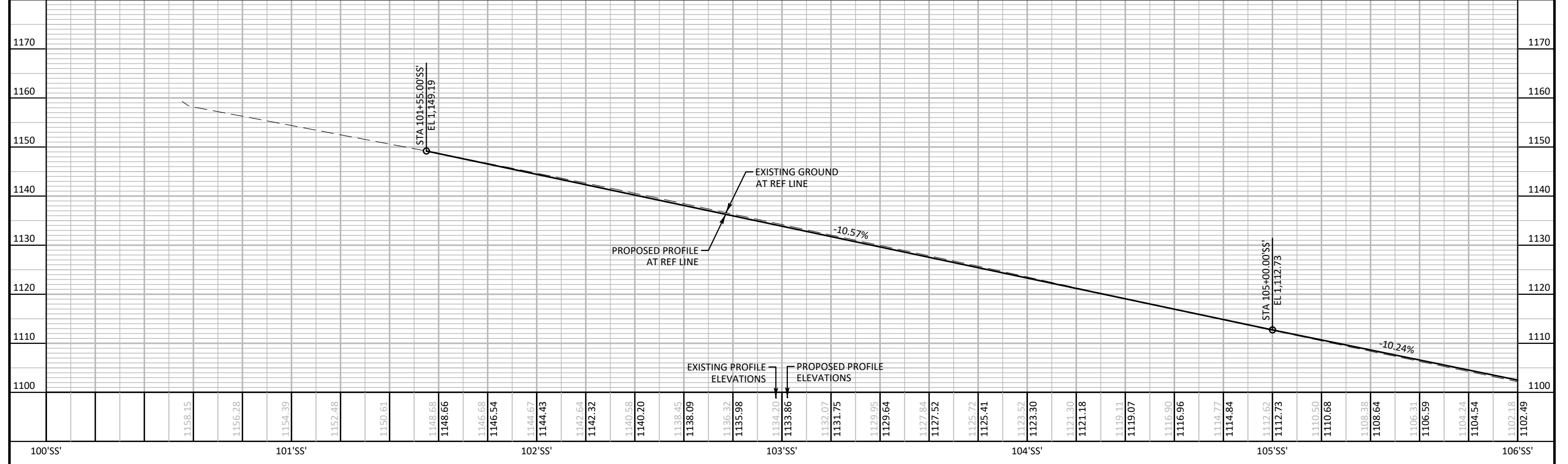

Station	Existing Profile Elevations	Proposed Profile Elevations
100+00	1158.15	
100+10	1156.28	
100+20	1154.39	
100+30	1152.48	
100+40	1150.61	
100+50	1148.68	
100+60	1146.66	
100+70	1146.68	
100+80	1146.54	
100+90	1144.67	
101+00	1144.43	
101+10	1142.64	
101+20	1142.32	
101+30	1140.58	
101+40	1140.20	
101+50	1138.45	
101+60	1138.09	
101+70	1136.32	
101+80	1135.98	
101+90	1134.20	
102+00	1133.86	
102+10	1132.07	
102+20	1131.75	
102+30	1129.95	
102+40	1129.64	
102+50	1127.84	
102+60	1127.52	
102+70	1125.72	
102+80	1125.41	
102+90	1123.52	
103+00	1123.30	
103+10	1121.30	
103+20	1121.18	
103+30	1119.11	
103+40	1119.07	
103+50	1116.90	
103+60	1116.96	
103+70	1114.77	
103+80	1114.84	
103+90	1112.63	
104+00	1112.73	
104+10	1110.50	
104+20	1110.68	
104+30	1108.38	
104+40	1108.64	
104+50	1106.31	
104+60	1106.59	
104+70	1104.24	
104+80	1104.54	
104+90	1102.18	
105+00	1102.49	

PROJECT NO: 5305-00-71 HWY: CTH SS COUNTY: VERNON PLAN AND PROFILE: CTH SS SHEET: E

RICHARD A & PAMELA J SOLTAU
ID: 028-00373-0000

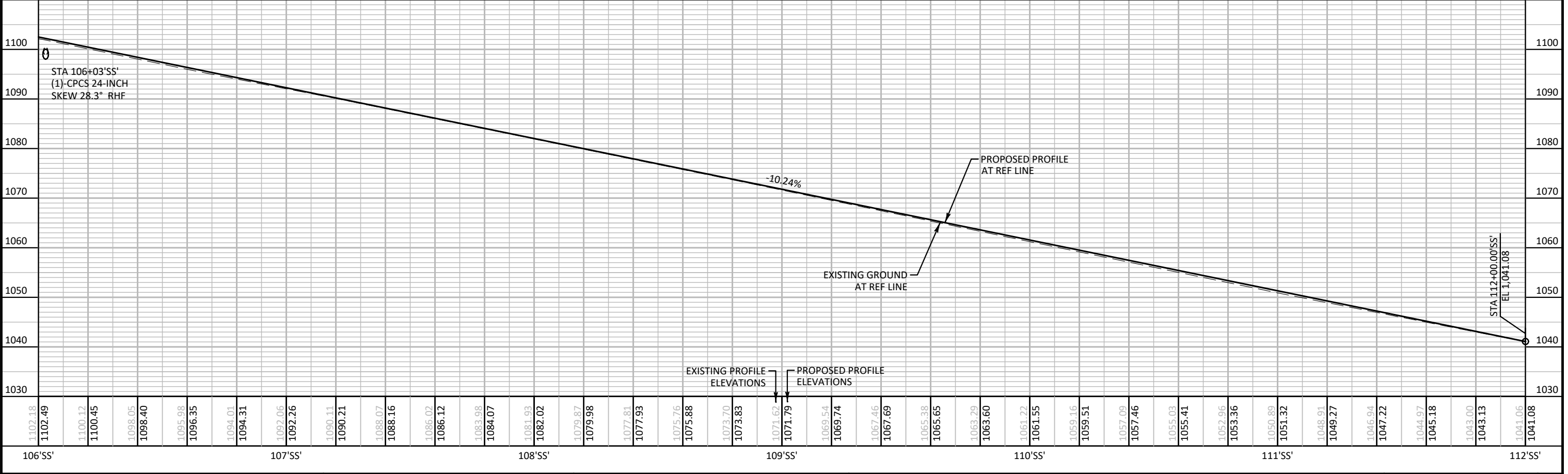
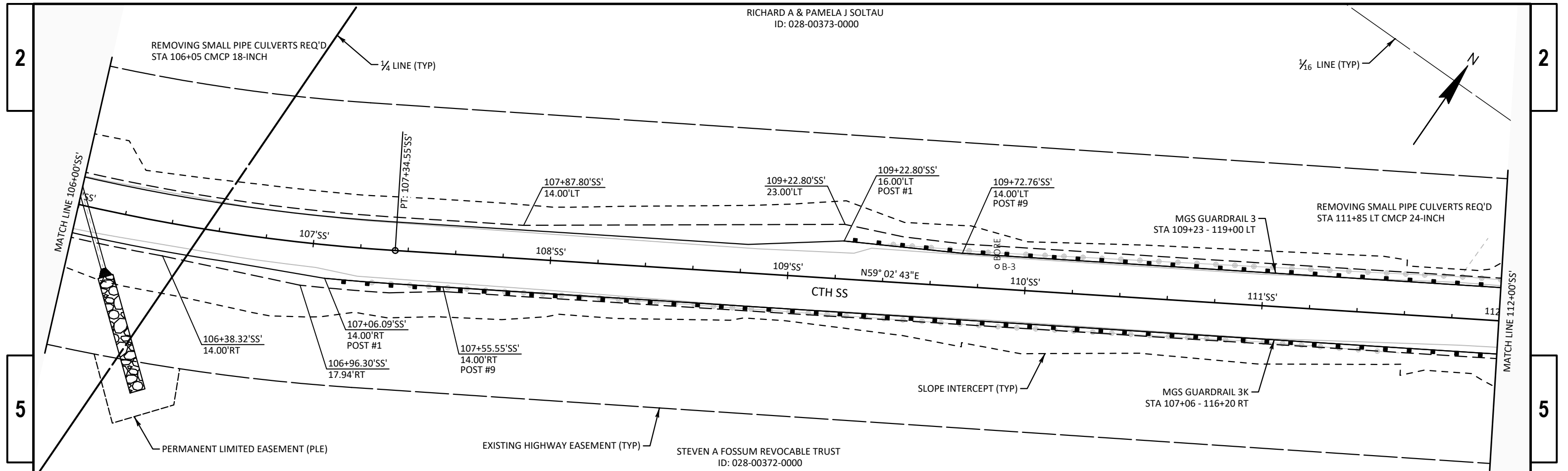

PROJECT NO: 5305-00-71	HWY: CTH SS	COUNTY: VERNON	PLAN AND PROFILE: CTH SS	SHEET E
------------------------	-------------	----------------	--------------------------	---------

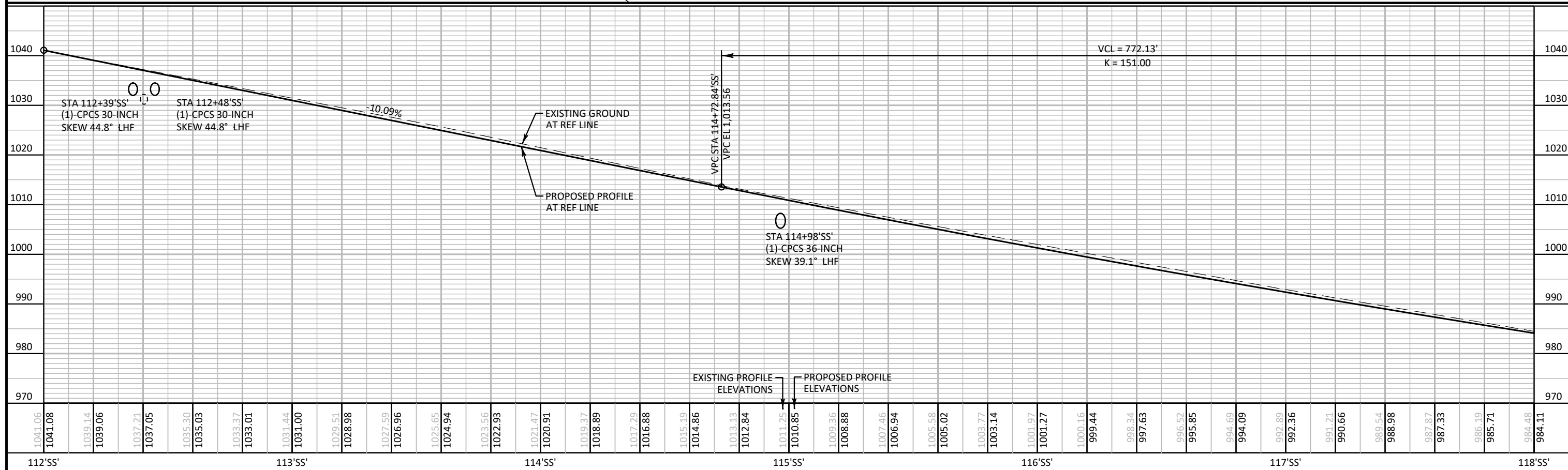
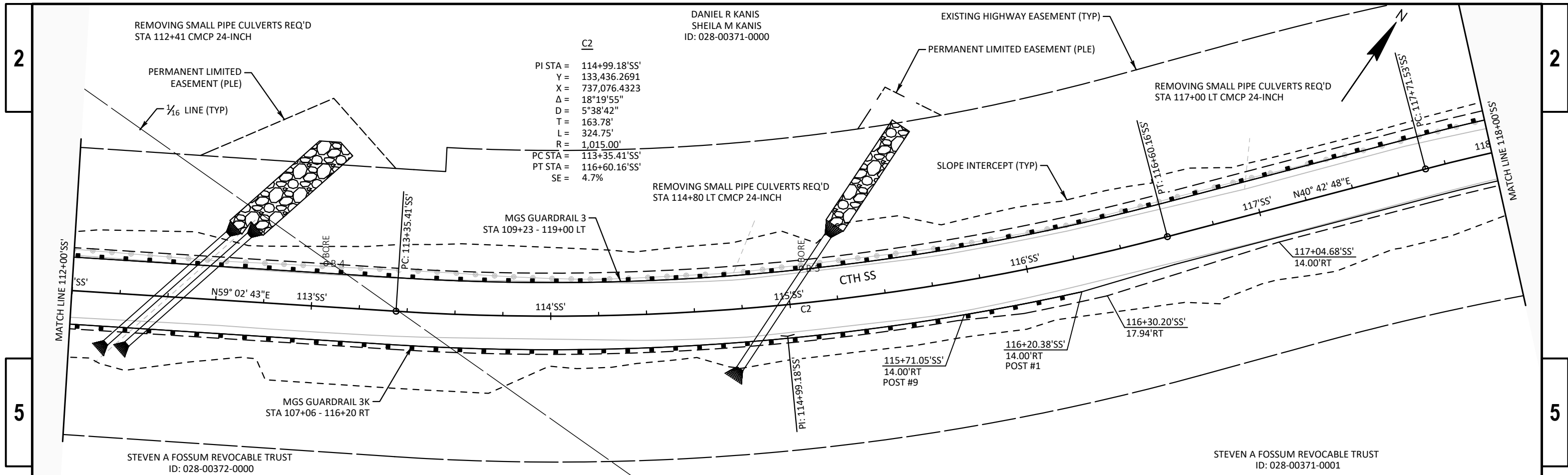

PROJECT NO: 5305-00-71 HWY: CTH SS COUNTY: VERNON PLAN AND PROFILE: CTH SS SHEET: **E**

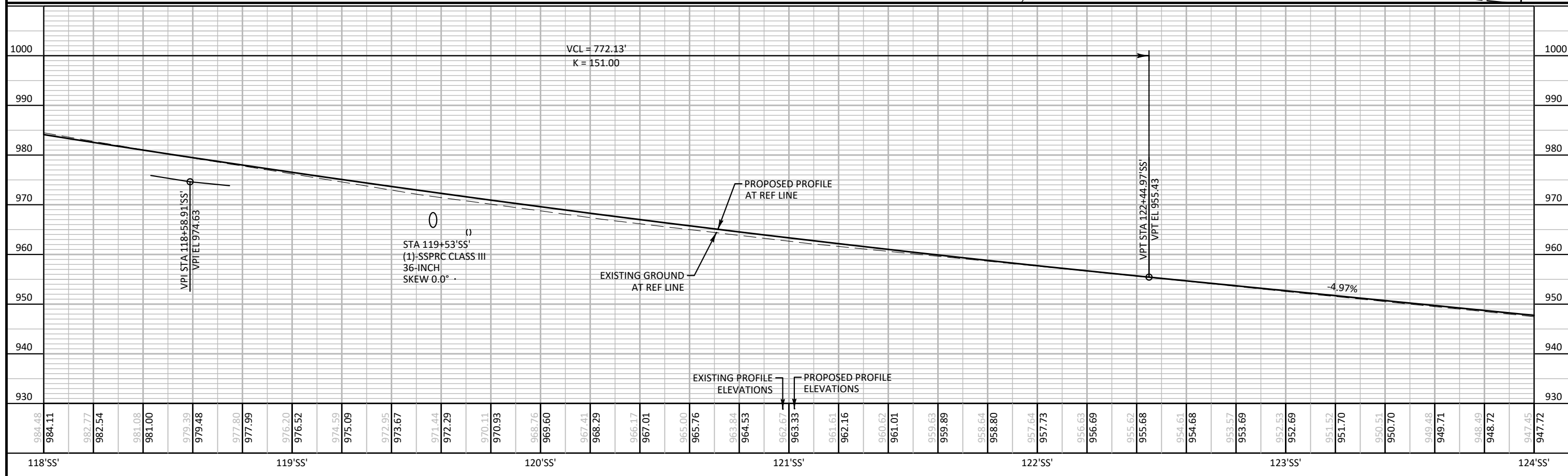
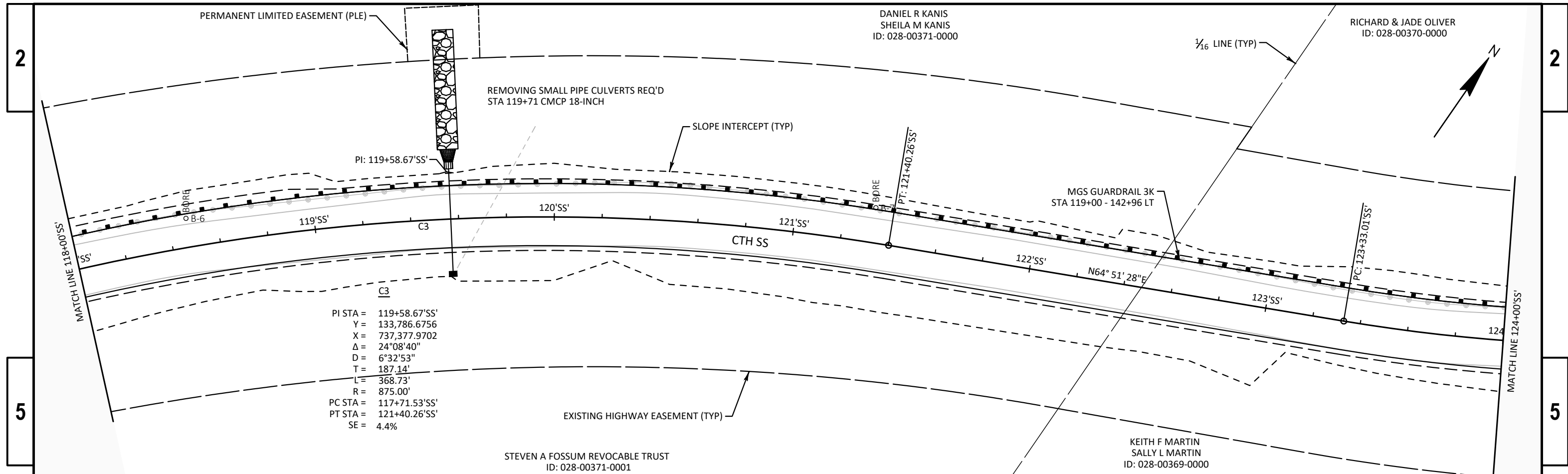

PROJECT NO: 5305-00-71 HWY: CTH SS COUNTY: VERNON PLAN AND PROFILE: CTH SS SHEET: E

RICHARD & JADE OLIVER
ID: 028-00370-0000

C4
PI STA = 124+61.87'SS'
Y = 134,002.8283
X = 737,838.5229
 Δ = 19°22'16"
D = 7°35'20"
T = 128.86'
L = 255.26'
R = 755.00'
PC STA = 123+33.01'SS'
PT STA = 125+88.27'SS'
SE = 4.7%

C5
PI STA = 128+61.69'SS'
Y = 134,284.8556
X = 738,125.3832
 Δ = 13°27'28"
D = 3°54'40"
T = 172.85'
L = 344.10'
R = 1,465.00'
PC STA = 126+88.84'SS'
PT STA = 130+32.94'SS'
SE = 3.4%

KEITH F MARTIN
SALLY L MARTIN
ID: 028-00369-0000

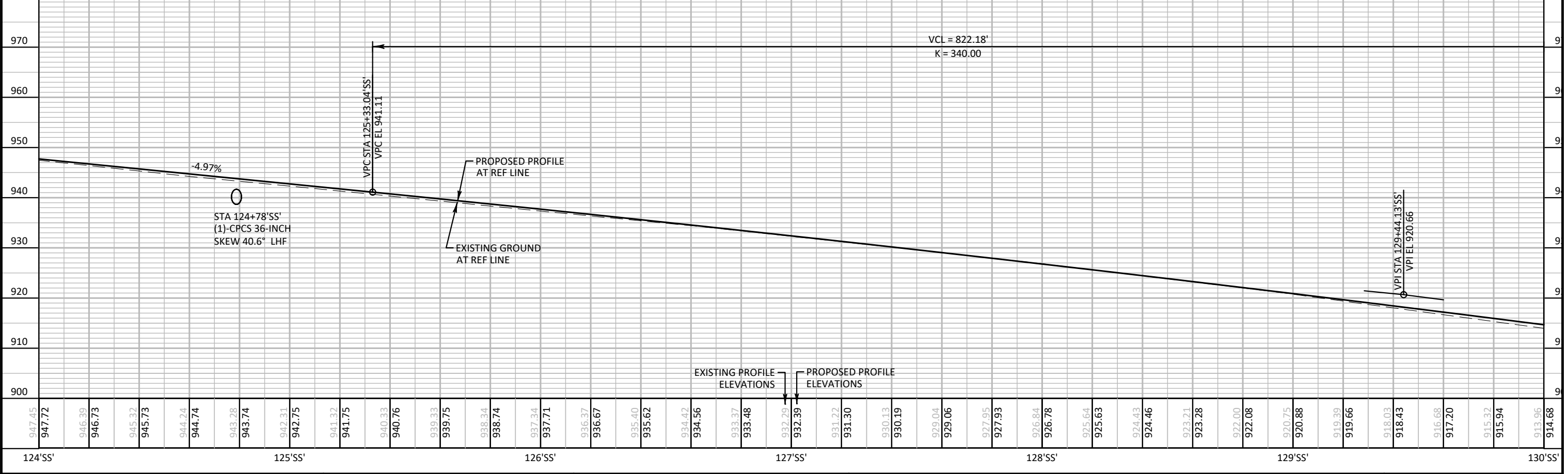
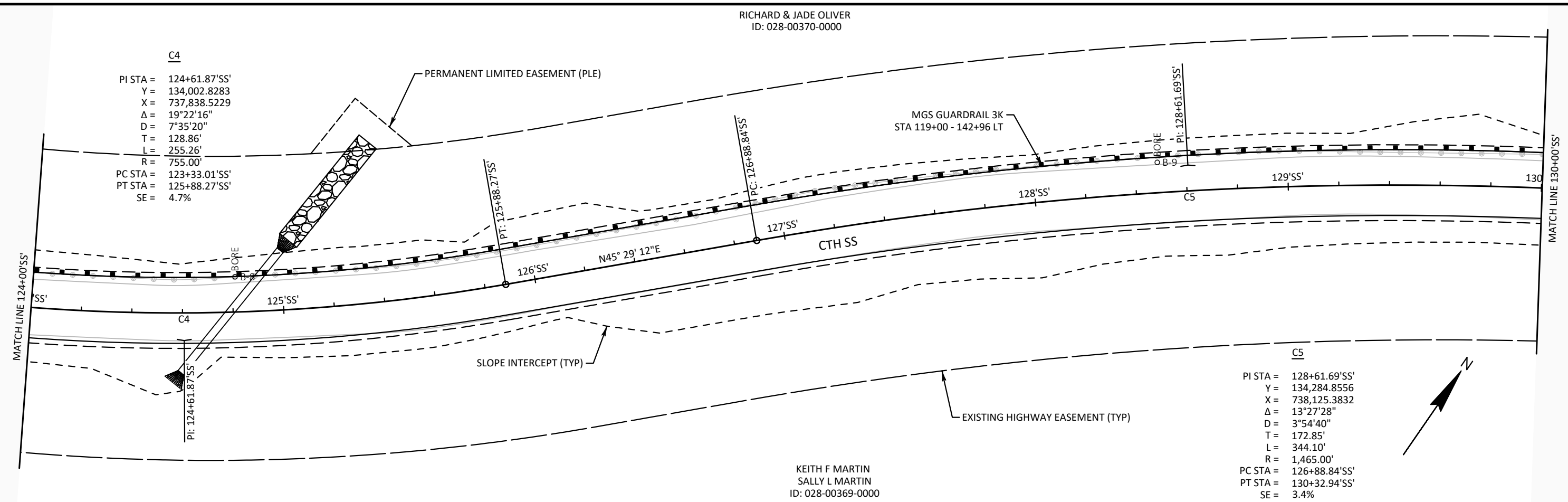

PROJECT NO: 5305-00-71 HWY: CTH SS COUNTY: VERNON PLAN AND PROFILE: CTH SS SHEET: E

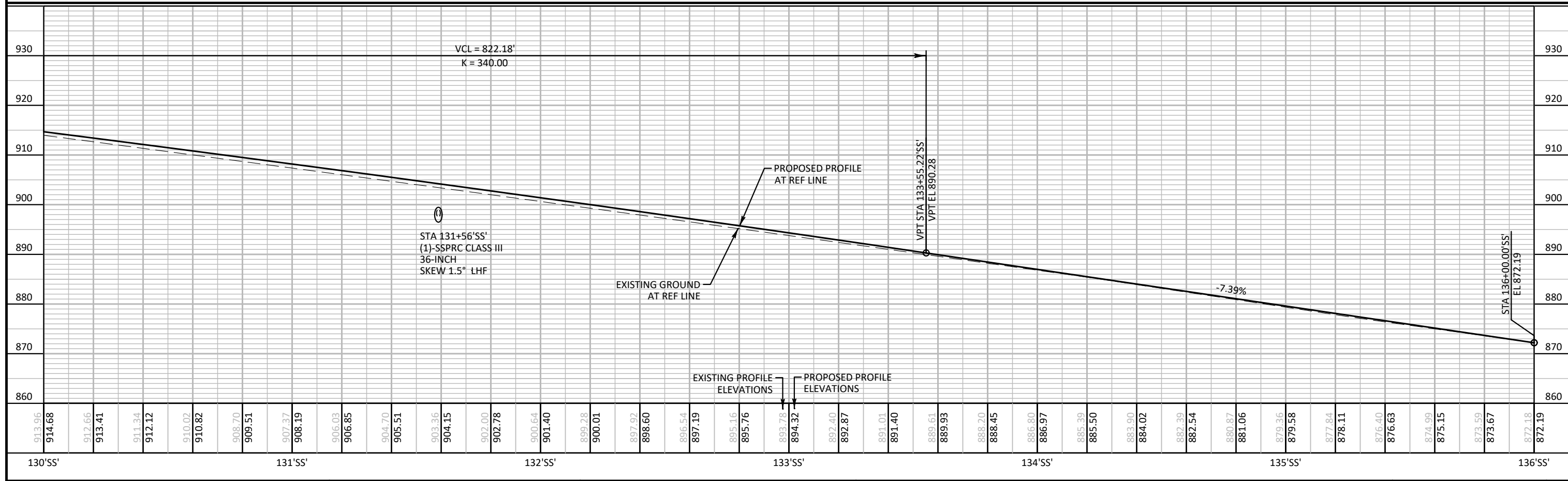
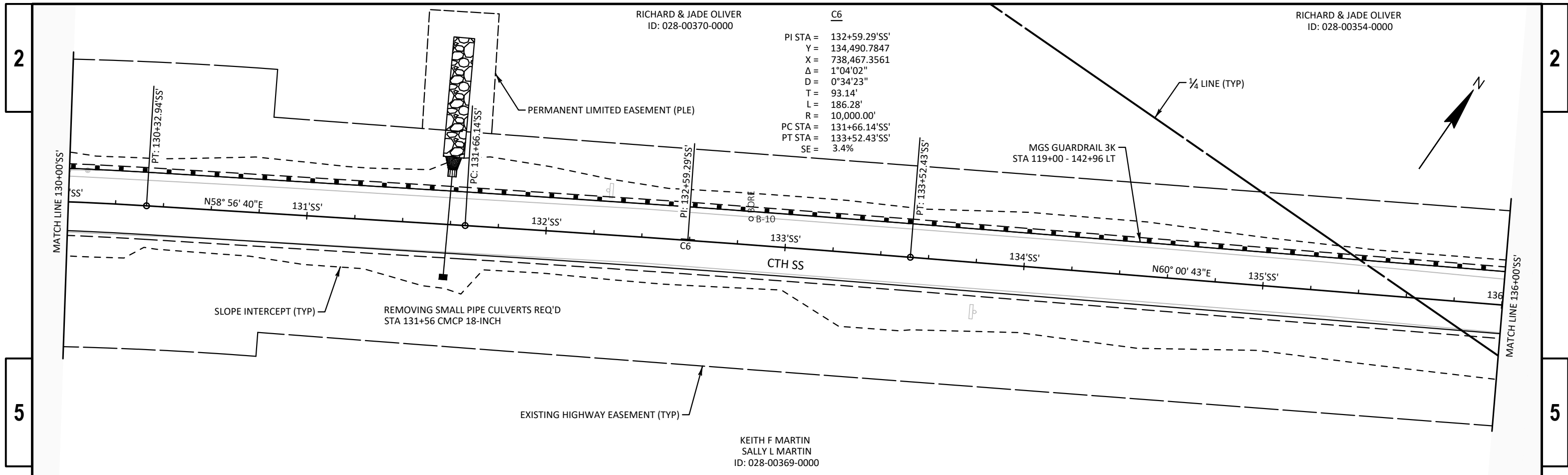

PROJECT NO: 5305-00-71	HWY: CTH SS	COUNTY: VERNON	PLAN AND PROFILE: CTH SS	SHEET	E
------------------------	-------------	----------------	--------------------------	-------	----------

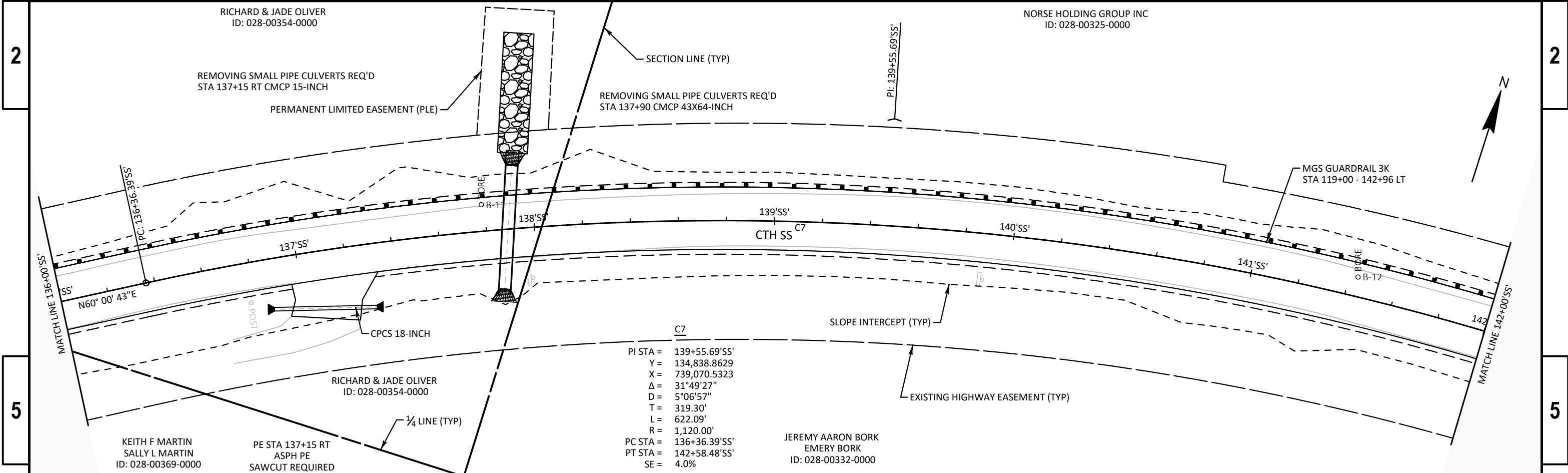

C7
 PI STA = 139+55.69'SS'
 Y = 134,838.8629
 X = 739,070.5323
 Δ = 31°49'27"
 D = 5°06'57"
 T = 319.30'
 L = 622.09'
 R = 1,120.00'
 PC STA = 136+36.39'SS'
 PT STA = 142+58.48'SS'
 SE = 4.0%

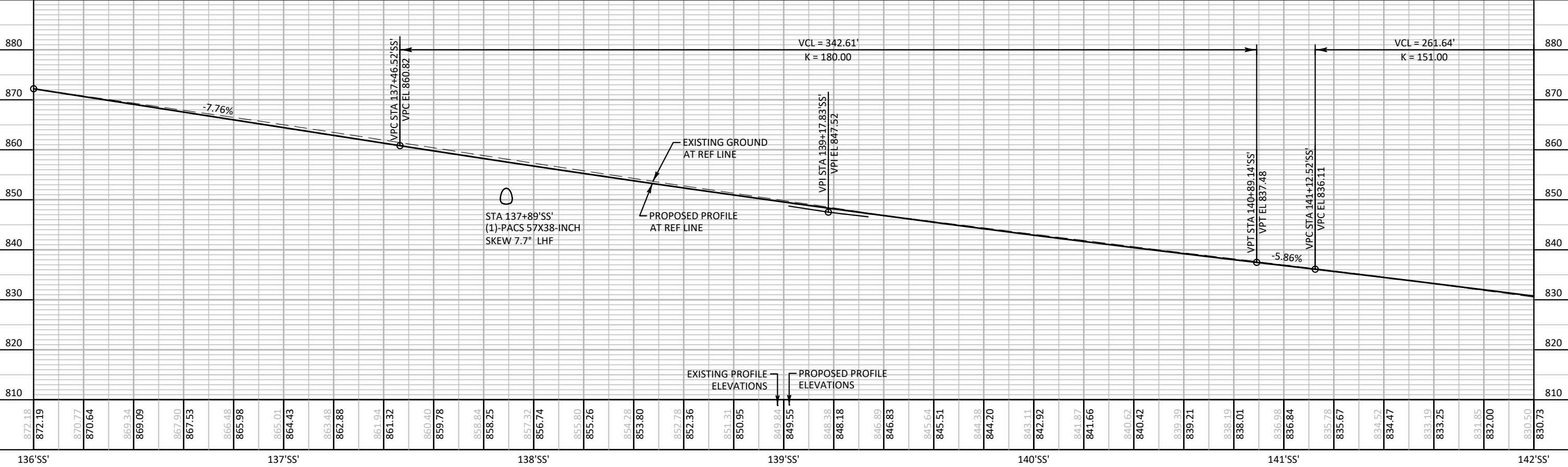

872.18	872.19	870.77	870.64	869.34	869.09	867.90	867.53	866.48	865.98	865.01	864.43	863.48	862.88	861.94	861.32	860.40	859.78	858.84	858.25	857.32	856.74	855.80	855.26	854.28	853.80	852.78	852.36	851.31	850.95	849.84	849.55	848.38	848.18	846.89	846.83	845.64	845.51	844.38	844.20	843.11	842.92	841.87	841.66	840.62	840.42	839.39	839.21	838.19	838.01	836.98	836.84	835.78	835.67	834.52	834.47	833.19	833.25	831.85	831.85	832.00	830.50	830.73							
																	EXISTING PROFILE ELEVATIONS											PROPOSED PROFILE ELEVATIONS																																									
136'SS'										137'SS'										138'SS'										139'SS'										140'SS'										141'SS'										142'SS'									

PROJECT NO: 5305-00-71 | HWY: CTH SS | COUNTY: VERNON | PLAN AND PROFILE: CTH SS | SHEET: E

Standard Detail Drawing List

08A05-20B	INLET COVERS TYPE B, B-A, C, MS, MS-A, & WM
08C08-02	INLETS MEDIAN 1 AND 2 GRATE
08E08-03	TYPICAL INSTALLATIONS OF EROSION BALES / TEMPORARY DITCH CHECKS
08E09-06	SILT FENCE
08E10-02	INLET PROTECTION TYPE A, B, C AND D
08E14-01	TRACKING PAD
08E15-01	CULVERT PIPE CHECK
08F01-11	APRON ENDWALLS FOR CULVERT PIPE
13C19-03	HMA LONGITUDINAL JOINTS
14B42-07A	MIDWEST GUARDRAIL SYSTEM (MGS) GUARDRAIL
14B42-07B	MIDWEST GUARDRAIL SYSTEM (MGS) GUARDRAIL
14B42-07C	MIDWEST GUARDRAIL SYSTEM (MGS) GUARDRAIL
14B42-07D	MIDWEST GUARDRAIL SYSTEM (MGS) GUARDRAIL
14B44-04A	MIDWEST GUARDRAIL SYSTEM ENERGY ABSORBING TERMINAL (MGS)
14B44-04B	MIDWEST GUARDRAIL SYSTEM ENERGY ABSORBING TERMINAL (MGS)
14B44-04C	MIDWEST GUARDRAIL SYSTEM ENERGY ABSORBING TERMINAL (MGS)
15A03-02A	FLEXIBLE MARKER POST FOR CULVERT END
15A03-02B	FLEXIBLE MARKER POST FOR CULVERT END
15C02-09A	BARRICADES AND SIGNS FOR MAINLINE CLOSURES
15C02-09B	BARRICADES AND SIGNS FOR VARIOUS CLOSURES
15C08-23A	PERMANENT LONGITUDINAL PAVEMENT MARKINGS

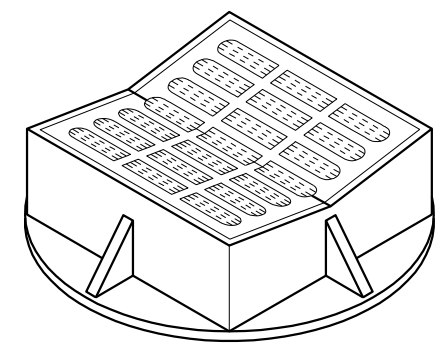
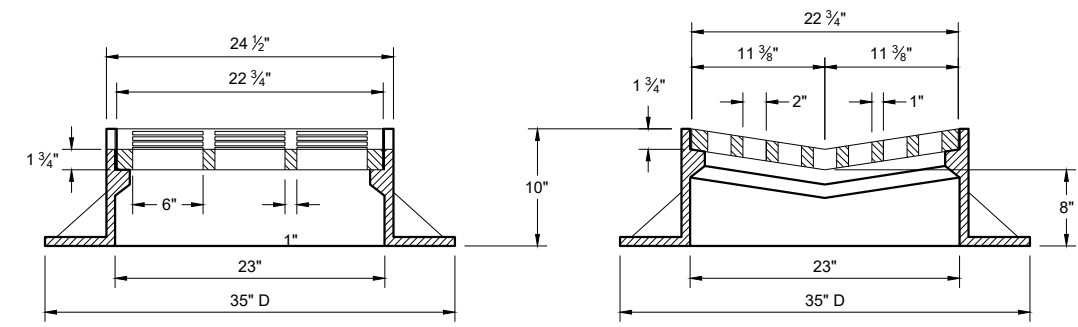

TYPE "B"

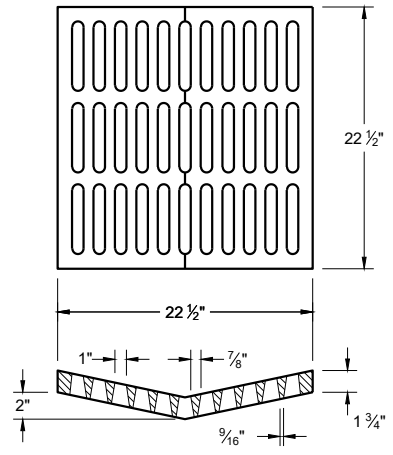
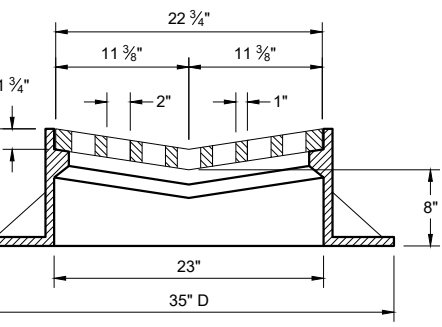

ALTERNATIVE GRATE FOR TYPE "B" COVER

USE WHERE PEDESTRIAN OR BICYCLE TRAFFIC IS POSSIBLE
NOTED AS TYPE B - A ON THE DRAINAGE TABLE

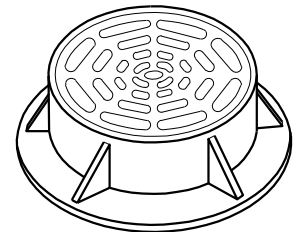
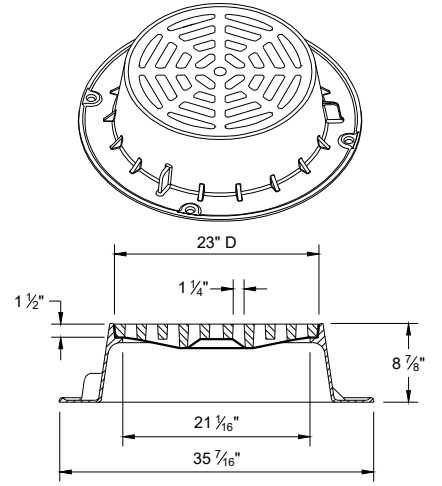

TYPE "C"

NOTE: EITHER CASTING IS ACCEPTABLE

GENERAL NOTES

DETAILS OF CONSTRUCTION, MATERIALS AND WORKMANSHIP NOT SHOWN ON THIS DRAWING SHALL CONFORM TO THE PERTINENT REQUIREMENTS OF THE STANDARD SPECIFICATIONS AND THE APPLICABLE SPECIAL PROVISIONS.

DETAIL DRAWINGS FOR PROPOSED ALTERNATE DESIGNS FOR CATCH BASIN, MANHOLE AND INLET COVERS SHALL BE SUBMITTED TO THE ENGINEER FOR APPROVAL PROVIDING THAT SUCH ALTERNATE DESIGNS MAKE PROVISION FOR EQUIVALENT CAPACITY AND STRENGTH.

ROUND FRAMES AND COVERS SHALL HAVE CONTINUOUSLY MACHINED BEARING SURFACES TO PREVENT ROCKING AND RATTLING.

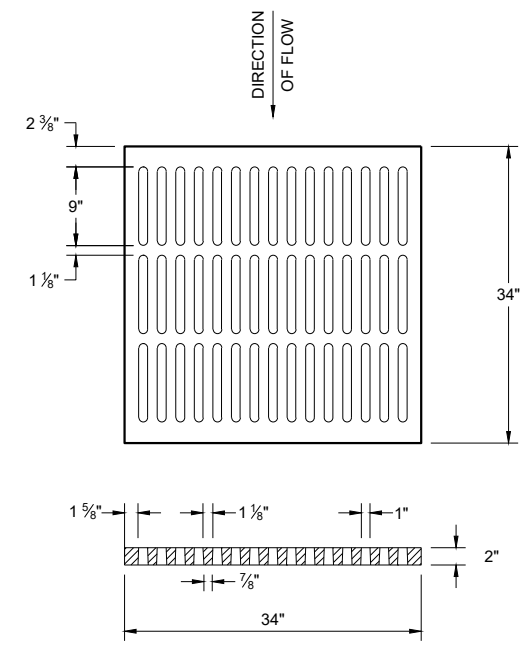

ALTERNATIVE TYPE "MS"

USE WHERE PEDESTRIAN OR BICYCLE TRAFFIC IS PERMITTED
NOTED AS TYPE MS-A ON THE DRAINAGE TABLE

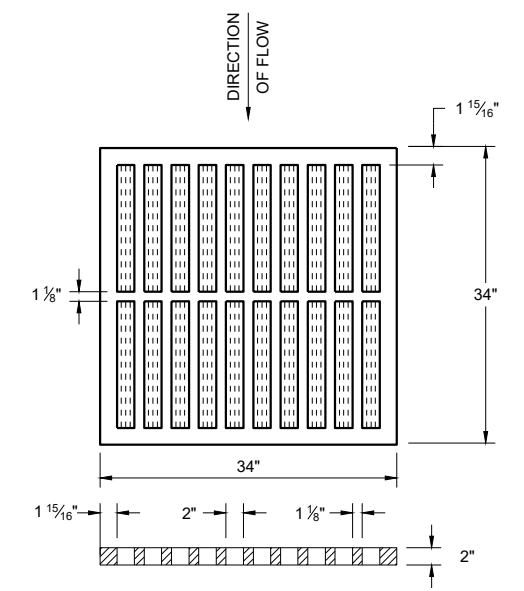

TYPE "MS"

USE ON FREEWAYS AND EXPRESSWAYS
NOTED AS TYPE MS ON THE DRAINAGE TABLE

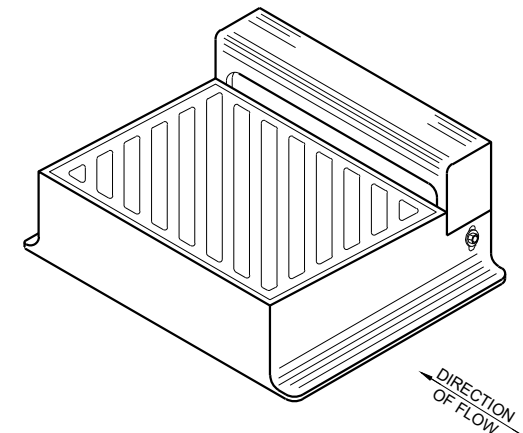

DIRECTION OF FLOW

DIAGONAL SLOTS SHALL BE ORIENTED TO THE DIRECTION OF FLOW AS ILLUSTRATED. GRATES ARE MANUFACTURED TO BE REVERSIBLE.

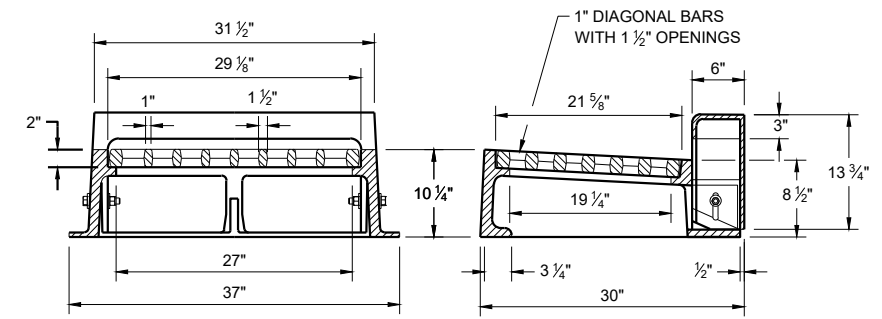

TYPE "WM"

NOTE: CURB BOX HEIGHT ADJUSTABLE 6" - 9"

6

6

SDD 08A05-20b

SDD 08A05-20b

**INLET COVERS
 TYPES B, B-A, C,
 MS, MS-A AND WM**

STATE OF WISCONSIN
 DEPARTMENT OF TRANSPORTATION

APPROVED
 July 2023 /S/ Rodney Taylor
 DATE ROADWAY STANDARDS DEVELOPMENT
 FHWA UNIT SUPERVISOR

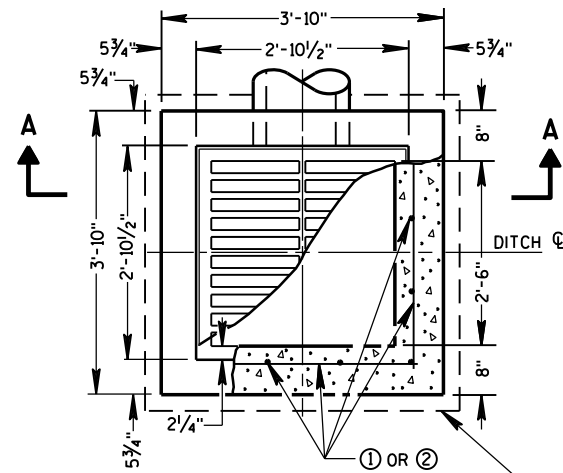

PLAN VIEW

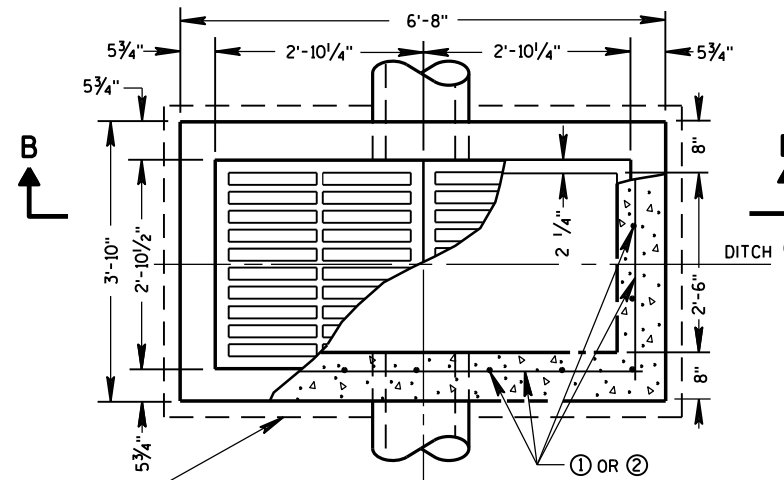

PLAN VIEW

4" OVERHANGING BASE ON REINFORCED CAST-IN-PLACE CONCRETE INLETS

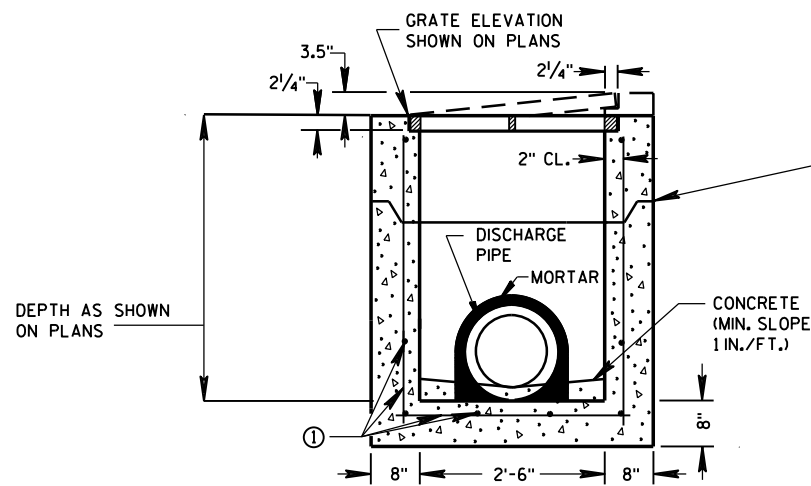

PRECAST REINFORCED CONCRETE SECTION A-A

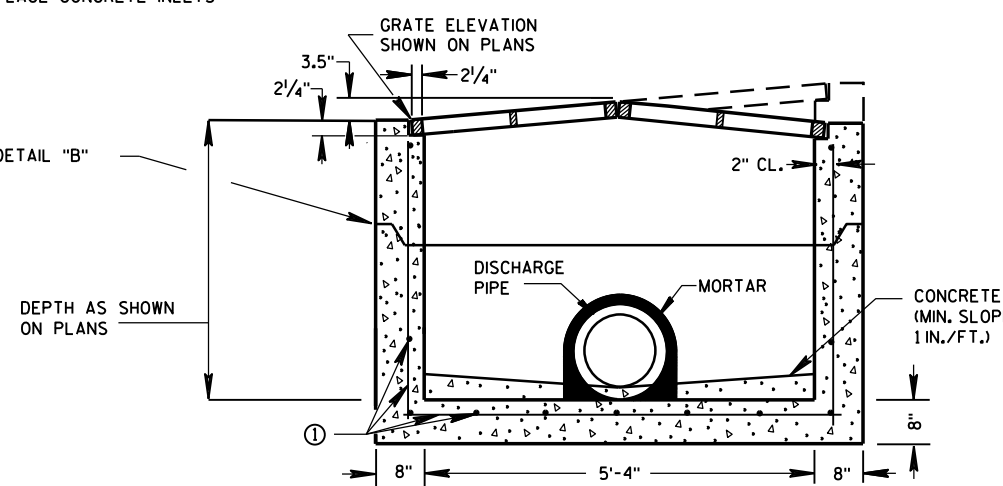

PRECAST REINFORCED CONCRETE SECTION B-B

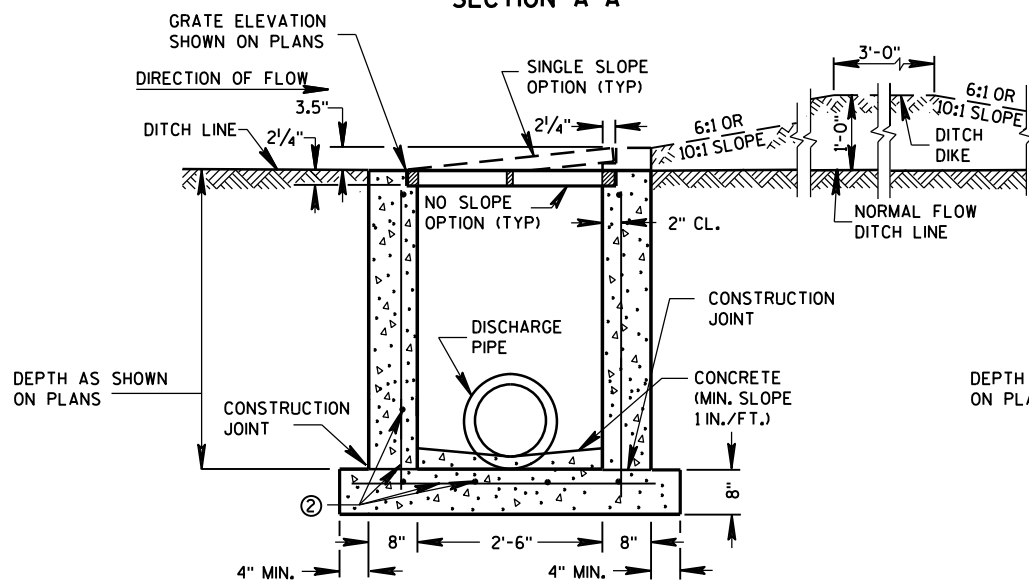

REINFORCED CAST-IN-PLACE CONCRETE SECTION A-A

INLETS MEDIAN 1 GRATE

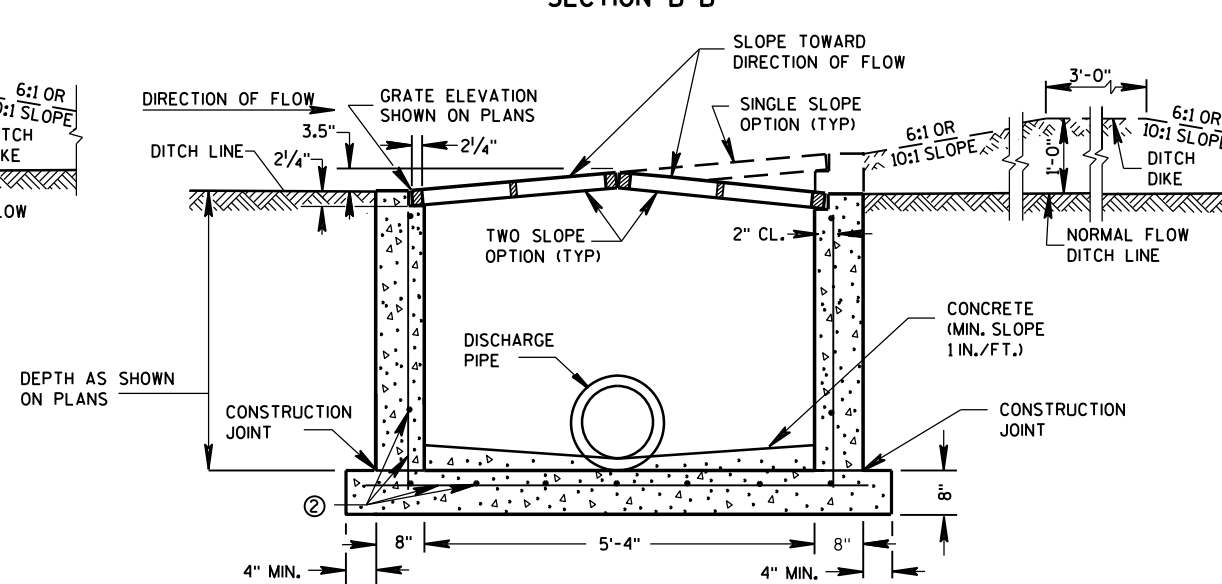

REINFORCED CAST-IN-PLACE CONCRETE SECTION B-B

INLETS MEDIAN 2 GRATE

GENERAL NOTES

DETAILS OF CONSTRUCTION, MATERIALS AND WORKMANSHIP NOT SHOWN ON THIS DRAWING SHALL CONFORM TO THE PERTINENT REQUIREMENTS OF THE STANDARD SPECIFICATIONS AND THE APPLICABLE SPECIAL PROVISIONS.

UNLESS OTHERWISE AUTHORIZED IN WRITING BY THE ENGINEER, THE CONTRACTOR SHALL NOT ORDER AND DELIVER PRECAST INLET UNITS REQUIRED FOR THE PROJECT UNTIL A LIST OF SIZES IS FURNISHED BY THE ENGINEER.

DETAILED DRAWINGS FOR PROPOSED ALTERNATE DESIGNS FOR INLETS WHICH MAY INCLUDE PRECAST REINFORCED CONCRETE INLETS, SHALL BE SUBMITTED TO THE ENGINEER FOR APPROVAL PROVIDING THAT SUCH ALTERNATE DESIGNS MAKE PROVISION FOR EQUIVALENT CAPACITY AND STRENGTH.

ALL MEDIAN INLETS ARE DESIGNATED ON THE PLANS AS "INLETS, IG-MS", ETC. THE FIRST NUMBER AND LETTER DESIGNATE THE TYPE OF STRUCTURE, AND THE FOLLOWING LETTERS DESIGNATE THE TYPE OF COVER TO BE USED TO COMPRISE THE COMPLETE UNIT. BASES SHALL BE PLACED ON A BED OF MATERIAL AT LEAST 6 INCHES IN DEPTH, WHICH MEETS THE REQUIREMENTS OF FOUNDATION BACKFILL. THIS BEDDING SHALL BE COMPACTED AND PROVIDE UNIFORM SUPPORT FOR THE ENTIRE AREA OF THE BASE.

ALL BAR STEEL REINFORCEMENT SHALL BE EMBEDDED 2 INCHES CLEAR UNLESS OTHERWISE SHOWN OR NOTED.

PRECAST REINFORCED RISERS SHALL HAVE A TONGUE AND GROOVE JOINT WITH TONGUE UP OR DOWN.

ALL PRECAST INLET UNITS SHALL CONFORM TO THE PERTINENT REQUIREMENTS OF ASTM C 913.

MAXIMUM INSIDE PIPE DIAMETER DETERMINED BY 3" CLEARANCE ON EACH SIDE OF THE OUTSIDE WALL OF THE PIPE. SEE DETAIL "A". ASSUMES PIPE ENTERS PERPENDICULAR TO THE STRUCTURE.

- ① FOR PRECAST INLETS PROVIDE REINFORCING STEEL IN ACCORDANCE TO ASTM C 913.
- ② CONTRACTOR TO PROVIDE DRAWING(S) STAMPED BY A PROFESSIONAL ENGINEER FOR STEEL REINFORCING DESIGN FOR CAST-IN-PLACE STRUCTURES.

PIPE MATRIX

INLET SIZE	MAXIMUM INSIDE PIPE DIAMETER	
	WIDTH (IN)	LENGTH (IN)
1 GRATE	18	18
2 GRATE	18	42

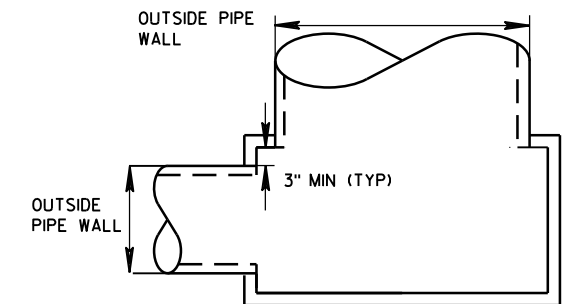

DETAIL "A"

JOINTS TO BE SEALED WITH A BUTYL RUBBER SEAL PER SEALANT MANUFACTURERS RECOMMENDATIONS CONFORMING TO ASTM C 990 (TYP)

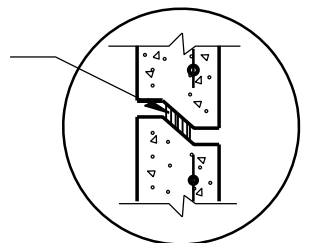

DETAIL "B"

INLETS MEDIAN 1 AND 2 GRATE

STATE OF WISCONSIN
DEPARTMENT OF TRANSPORTATION

APPROVED
Sept., 2016 /S/ Rodney Taylor
DATE ROADWAY STANDARDS DEVELOPMENT
FHWA UNIT SUPERVISOR

WOOD STAKES (2 PER BALE)
NOMINAL 2" X 2" X 30" MIN.
LENGTH OR EQUIVALENT

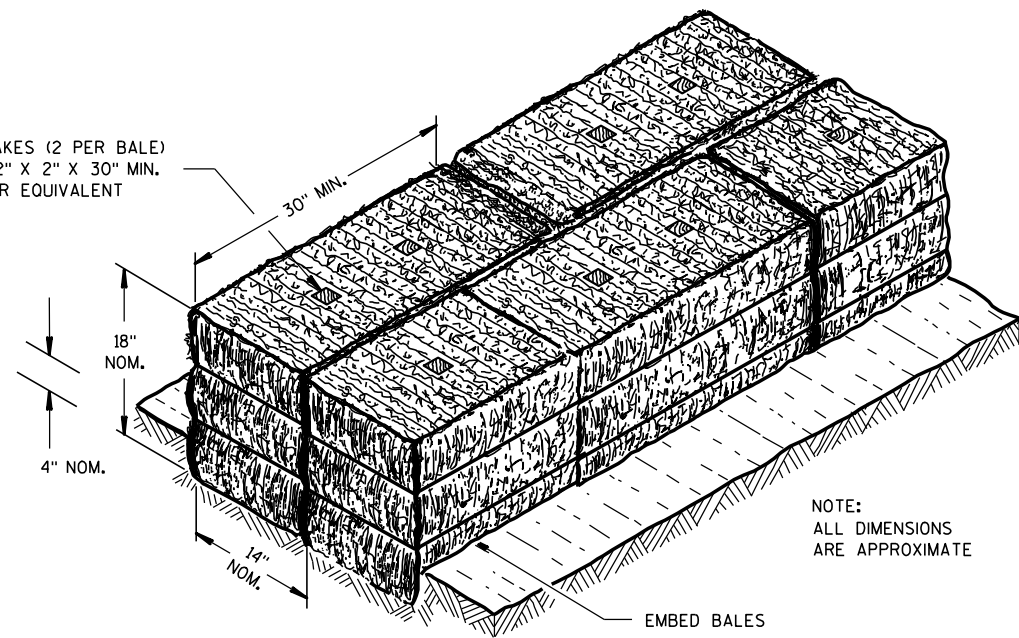

NOTE:
ALL DIMENSIONS
ARE APPROXIMATE

EMBED BALES

SECTION A-A

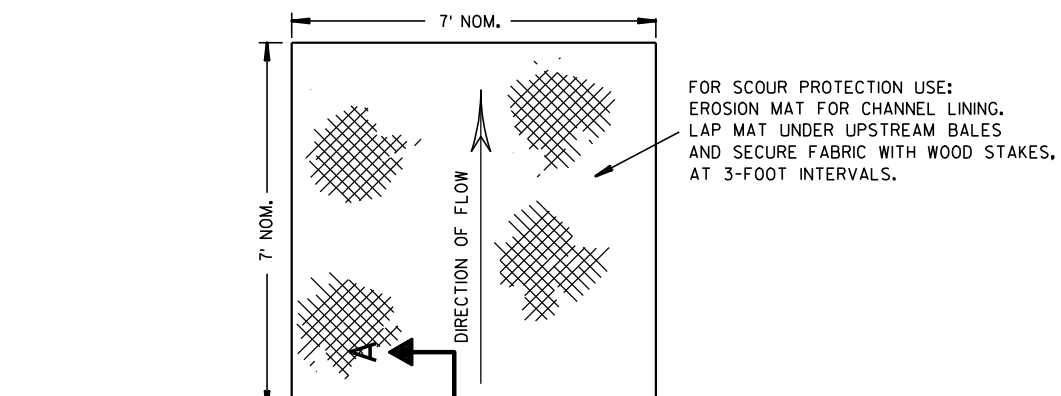

FOR SCOUR PROTECTION USE:
EROSION MAT FOR CHANNEL LINING.
LAP MAT UNDER UPSTREAM BALES
AND SECURE FABRIC WITH WOOD STAKES,
AT 3-FOOT INTERVALS.

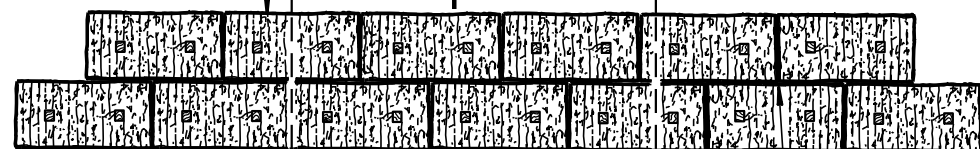

STAGGER JOINTS BETWEEN ADJACENT
ROWS OF BALES.

PLAN VIEW

BOTTOM ELEVATION OF END BALE SHALL
BE EQUAL TO OR GREATER THAN TOP OF
LOWEST MIDDLE BALE.

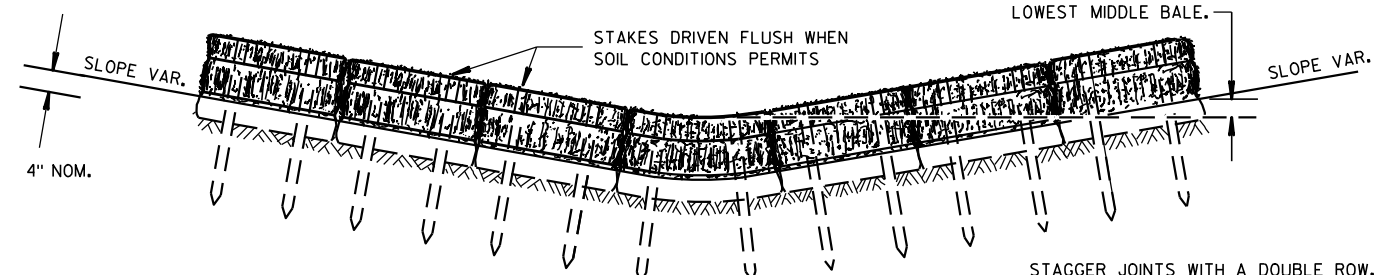

FRONT ELEVATION

TEMPORARY DITCH CHECK USING EROSION BALES ①

GENERAL NOTES

DETAILS OF CONSTRUCTION, MATERIALS AND WORKMANSHIP NOT SHOWN ON THIS DRAWING SHALL CONFORM TO THE PERTINENT REQUIREMENTS OF THE STANDARD SPECIFICATIONS AND THE APPLICABLE SPECIAL PROVISIONS.

- ① TEMPORARY DITCH CHECKS EITHER EROSION BALES OR MANUFACTURED SHALL BE PAID FOR UNDER THE BID ITEM OF TEMPORARY DITCH CHECK. THE DEPARTMENT WILL NOT PAY FOR TEMPORARY DITCH CHECKS CONSTRUCTED OF A SINGLE ROW OF EROSION BALES.

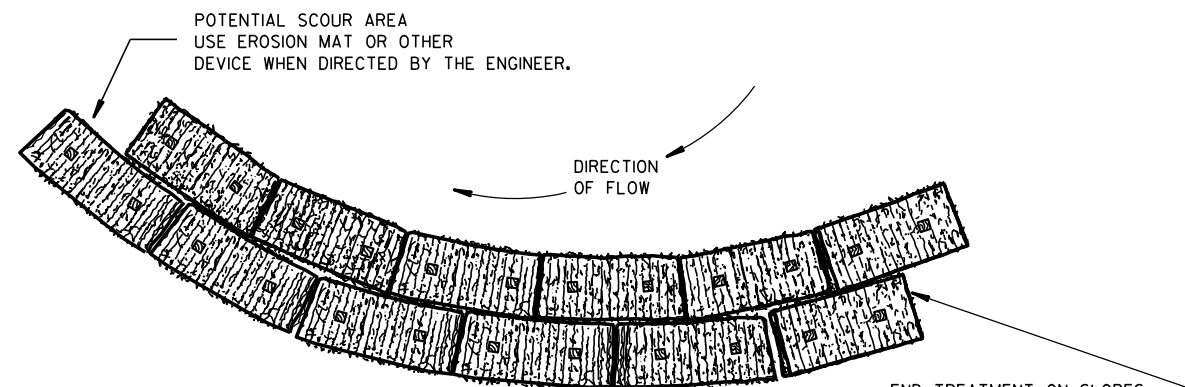

PLAN VIEW

WHEN ALTERING THE DIRECTION OF FLOW

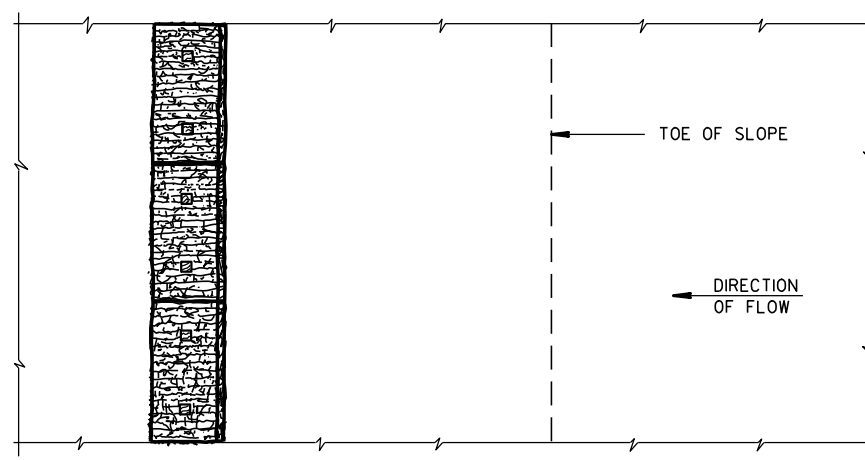

PLAN VIEW

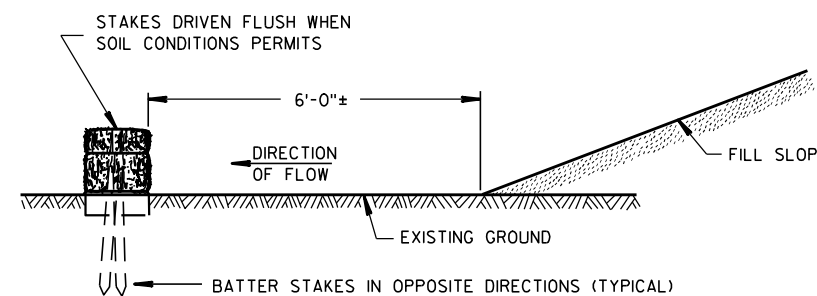

FRONT ELEVATION

WHEN EXISTING GROUND SLOPES AWAY FROM FILL SLOPE

EROSION BALES FOR SHEET FLOW

TYPICAL INSTALLATIONS OF
EROSION BALES / TEMPORARY
DITCH CHECKS

STATE OF WISCONSIN
DEPARTMENT OF TRANSPORTATION

APPROVED
 6/04/02 /S/ Beth Canestra
 DATE CHIEF ROADWAY DEVELOPMENT ENGINEER
 FHWA

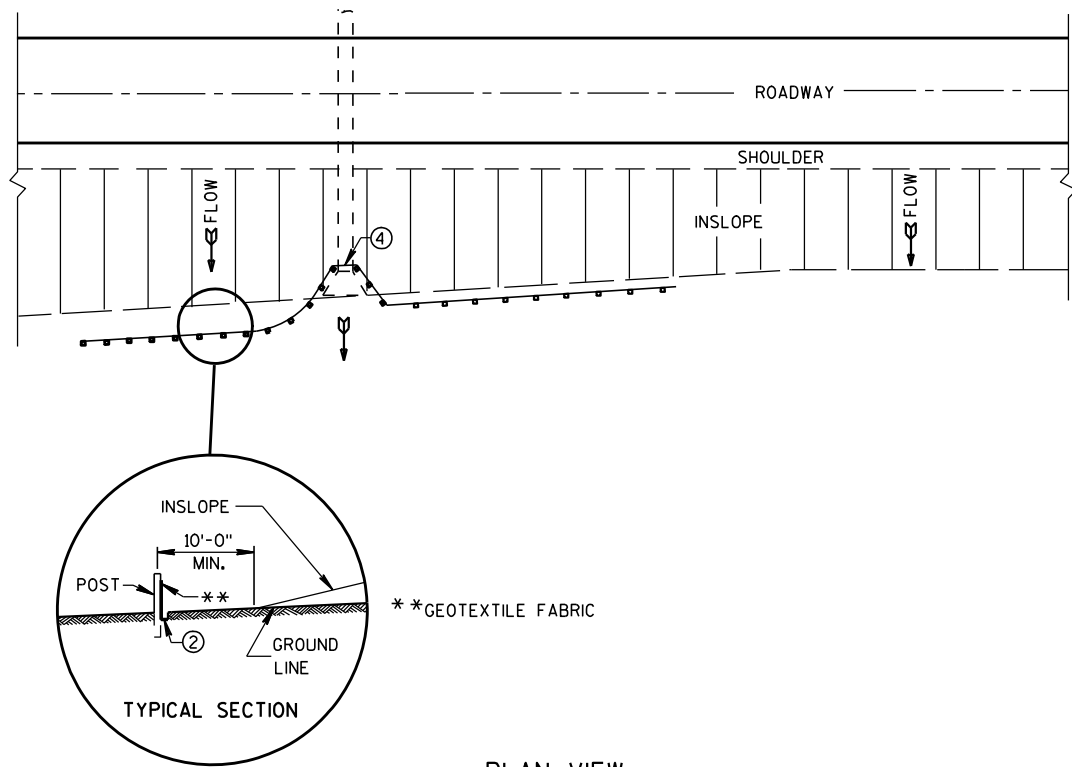

PLAN VIEW
TYPICAL APPLICATION OF SILT FENCE

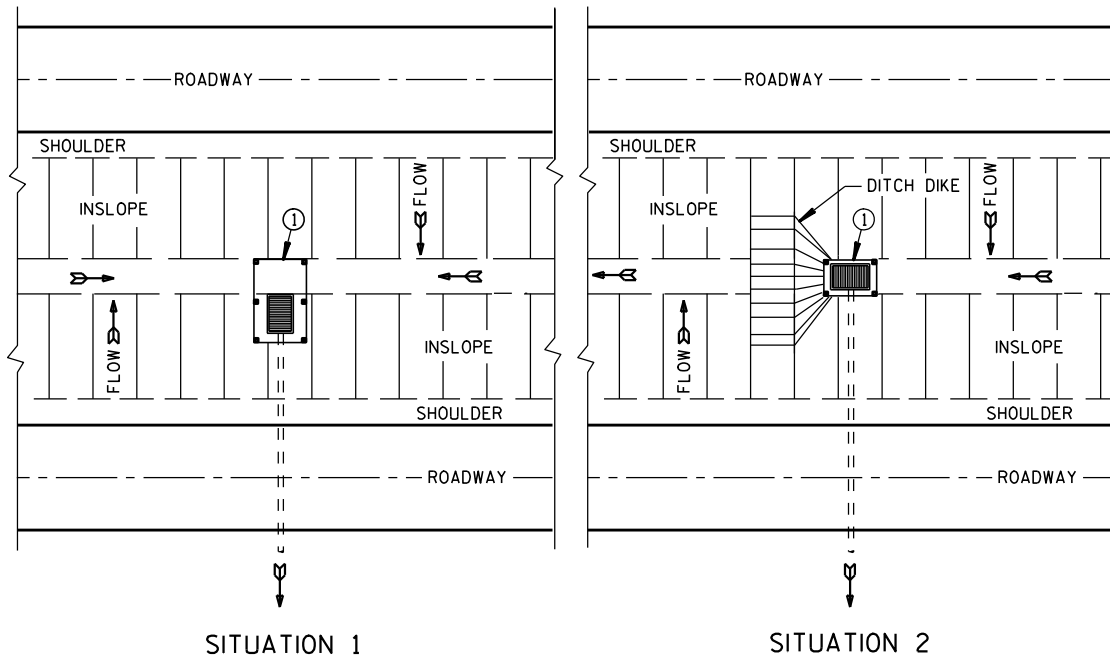

SITUATION 1 SITUATION 2
PLAN VIEW
SILT FENCE AT MEDIAN SURFACE DRAINS

GENERAL NOTES

DETAILS OF CONSTRUCTION NOT SHOWN ON THIS DRAWING SHALL CONFORM TO THE PERTINENT REQUIREMENTS OF THE STANDARD SPECIFICATIONS AND APPLICABLE SPECIAL PROVISIONS.

- ① HORIZONTAL BRACE REQUIRED WITH 2" X 4" WOODEN FRAME OR EQUIVALENT AT TOP OF POSTS.
- ② FOR MANUAL INSTALLATIONS THE TRENCH SHALL BE A MINIMUM OF 4" WIDE & 6" DEEP TO BURY AND ANCHOR THE GEOTEXTILE FABRIC. FOLD MATERIAL TO FIT TRENCH AND BACKFILL & COMPACT TRENCH WITH EXCAVATED SOIL.
- ③ WOOD POSTS SHALL BE A MINIMUM SIZE OF 1 1/8" X 1 1/8" OF OAK OR HICKORY.
- ④ SILT FENCE TO EXTEND ACROSS THE TOP OF THE PIPE.
- ⑤ CONSTRUCT SILT FENCE FROM A CONTINUOUS ROLL IF POSSIBLE BY CUTTING LENGTHS TO AVOID JOINTS. IF A JOINT IS NECESSARY USE ONE OF THE FOLLOWING TWO METHODS; A) OVERLAP THE END POSTS AND TWIST, OR ROTATE, AT LEAST 180 DEGREES, B) HOOK THE END OF EACH SILT FENCE LENGTH.

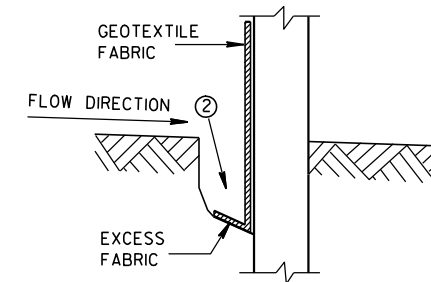

TRENCH DETAIL

NOTE: ADDITIONAL POST DEPTH OR TIE BACKS MAY BE REQUIRED IN UNSTABLE SOILS

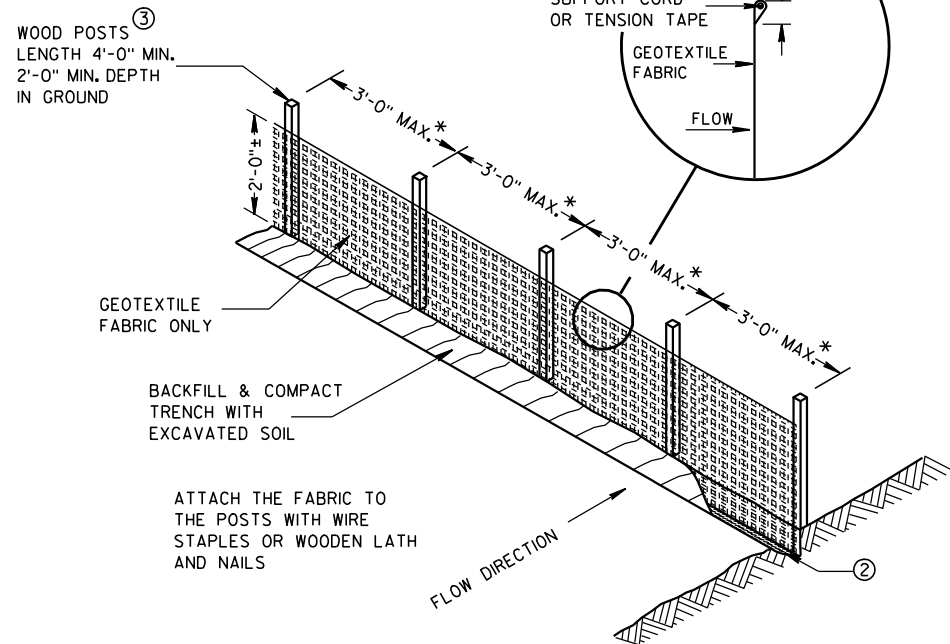

SILT FENCE

* NOTE: 8'-0" POST SPACING ALLOWED IF A WOVEN GEOTEXTILE FABRIC IS USED.

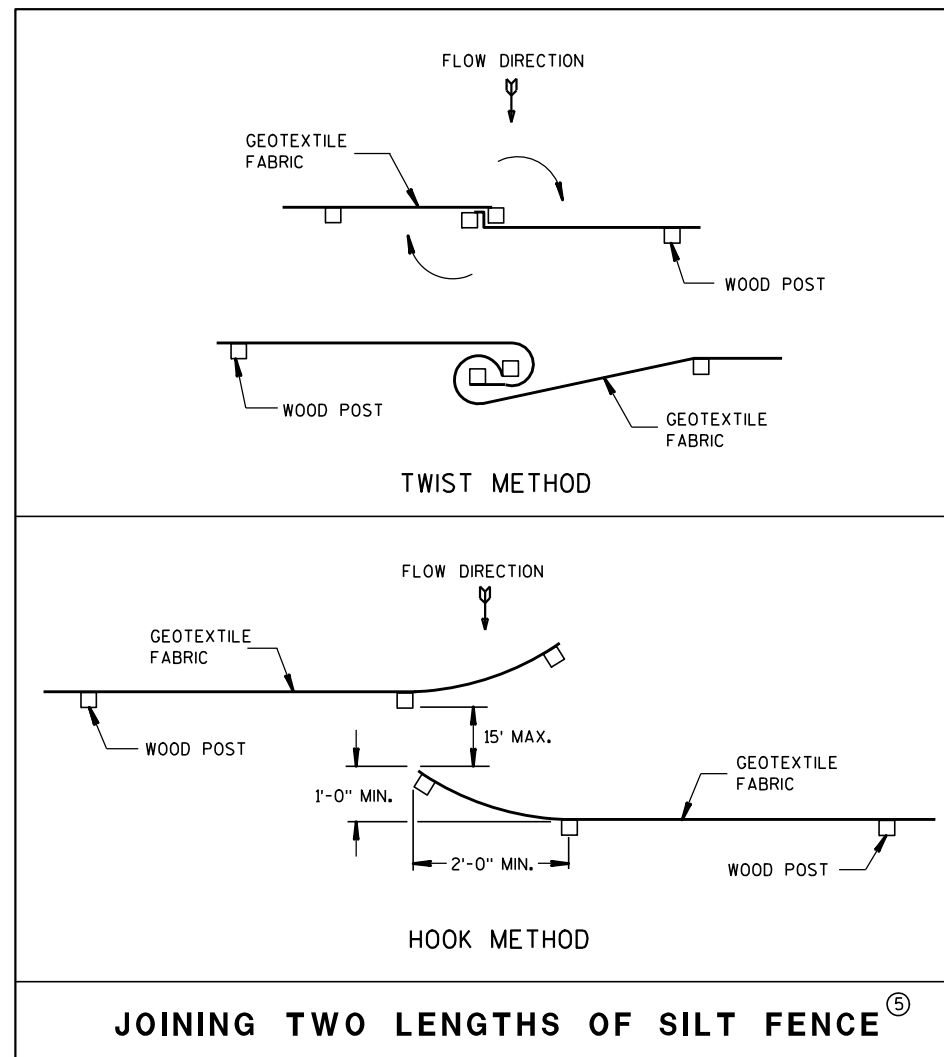

JOINING TWO LENGTHS OF SILT FENCE ⑤

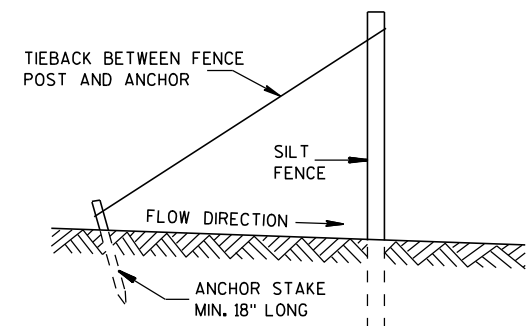

SILT FENCE TIE BACK
(WHEN REQUIRED BY THE ENGINEER)

SILT FENCE

STATE OF WISCONSIN
DEPARTMENT OF TRANSPORTATION

APPROVED

4-29-05
DATE

FHWA

/S/ Beth Canestra
CHIEF ROADWAY DEVELOPMENT ENGINEER

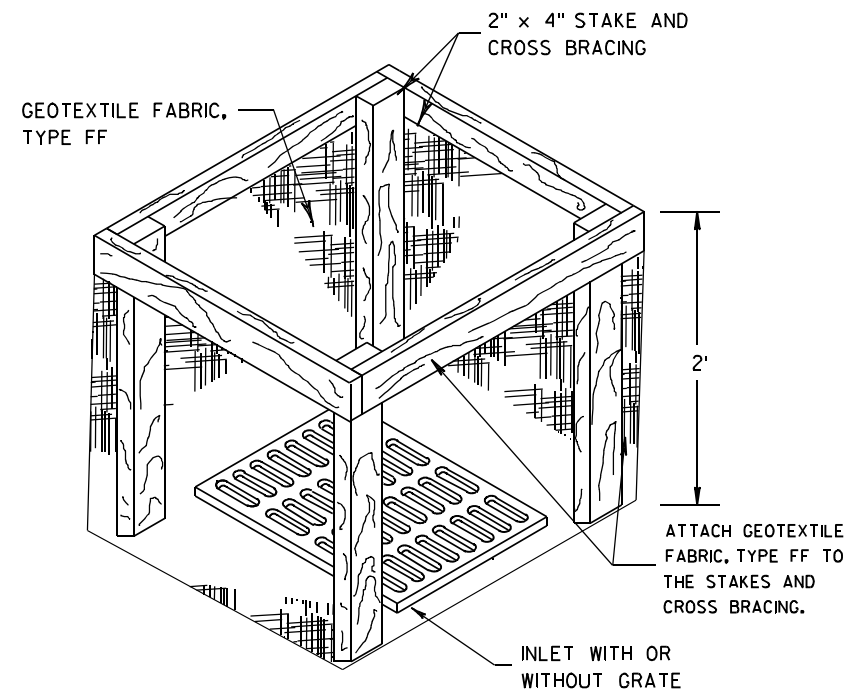
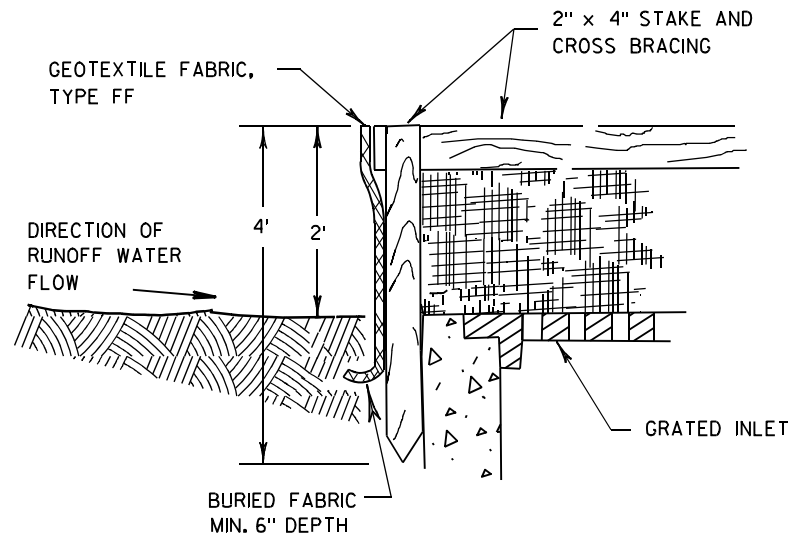

INLET PROTECTION, TYPE A

GENERAL NOTES

INLET PROTECTION DEVICES SHALL BE MAINTAINED OR REPLACED AT THE DIRECTION OF THE ENGINEER.

MANUFACTURED ALTERNATIVES APPROVED AND LISTED ON THE DEPARTMENT'S EROSION CONTROL PRODUCT ACCEPTABILITY LIST MAY BE SUBSTITUTED.

WHEN REMOVING OR MAINTAINING INLET PROTECTION, CARE SHALL BE TAKEN SO THAT THE SEDIMENT TRAPPED ON THE GEOTEXTILE FABRIC DOES NOT FALL INTO THE INLET. ANY MATERIAL FALLING INTO THE INLET SHALL BE REMOVED IMMEDIATELY.

- ① FINISHED SIZE, INCLUDING FLAP POCKETS WHERE REQUIRED, SHALL EXTEND A MINIMUM OF 10" AROUND THE PERIMETER TO FACILITATE MAINTENANCE OR REMOVAL.
- ② FOR INLET PROTECTION, TYPE C (WITH CURB BOX), AN ADDITIONAL 18" OF FABRIC IS WRAPPED AROUND THE WOOD AND SECURED WITH STAPLES. THE WOOD SHALL NOT BLOCK THE ENTIRE HEIGHT OF THE CURB BOX OPENING.
- ③ FLAP POCKETS SHALL BE LARGE ENOUGH TO ACCEPT WOOD 2X4.

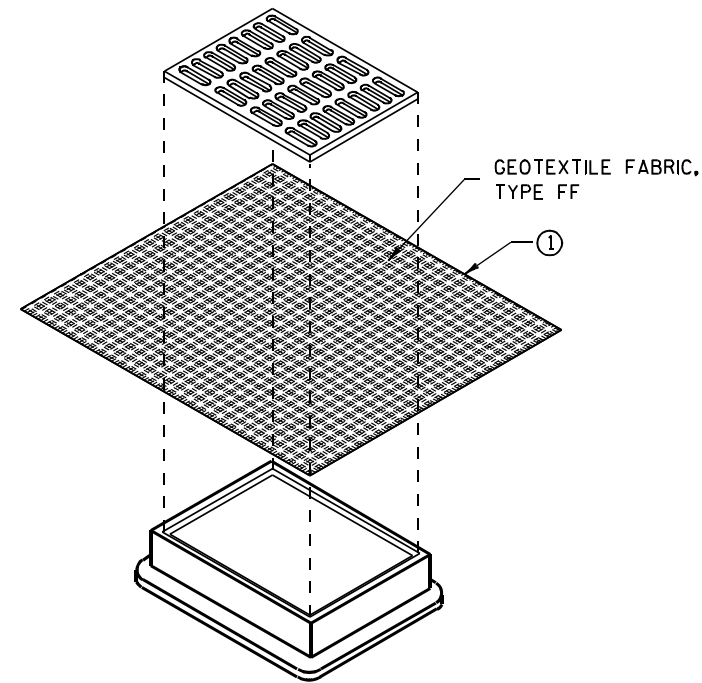

**INLET PROTECTION, TYPE B
(WITHOUT CURB BOX)**

(CAN BE INSTALLED IN ANY INLET WITHOUT A CURB BOX)

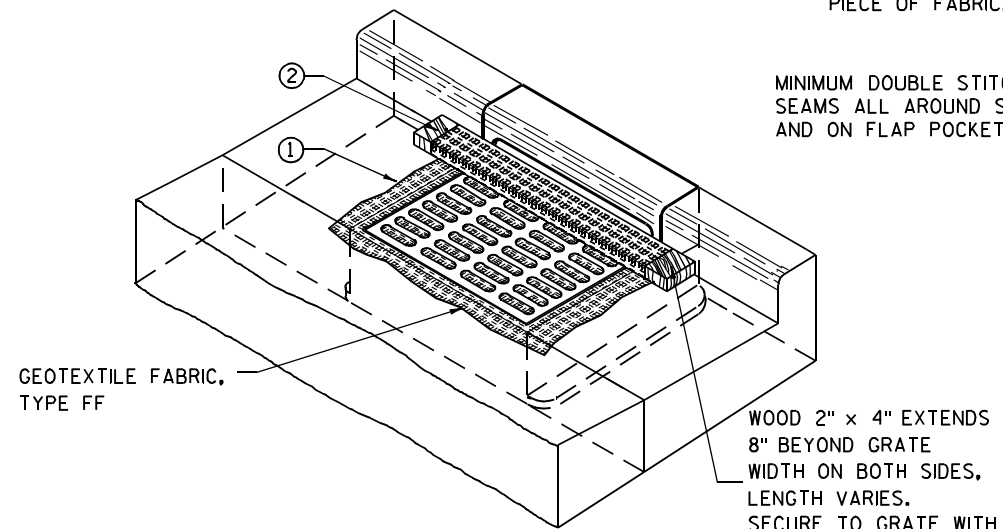

INLET PROTECTION, TYPE C (WITH CURB BOX)

INSTALLATION NOTES

TYPE B & C

TRIM EXCESS FABRIC IN THE FLOW LINE TO WITHIN 3" OF THE GRATE.

THE CONTRACTOR SHALL DEMONSTRATE A METHOD OF MAINTENANCE, USING A SEWN FLAP, HAND HOLDS OR OTHER METHOD TO PREVENT ACCUMULATED SEDIMENT FROM ENTERING THE INLET.

TYPE D

DO NOT INSTALL INLET PROTECTION TYPE D IN INLETS SHALLOWER THAN 30", MEASURED FROM THE BOTTOM OF THE INLET TO THE TOP OF THE GRATE.

TRIM EXCESS FABRIC IN THE FLOW LINE TO WITHIN 3" OF THE GRATE.

THE INSTALLED BAG SHALL HAVE A MINIMUM SIDE CLEARANCE, BETWEEN THE INLET WALLS AND THE BAG, MEASURED AT THE BOTTOM OF THE OVERFLOW HOLES, OF 3". WHERE NECESSARY THE CONTRACTOR SHALL CINCH THE BAG, USING PLASTIC ZIP TIES, TO ACHIEVE THE 3" CLEARANCE. THE TIES SHALL BE PLACED AT A MAXIMUM OF 4" FROM THE BOTTOM OF THE BAG.

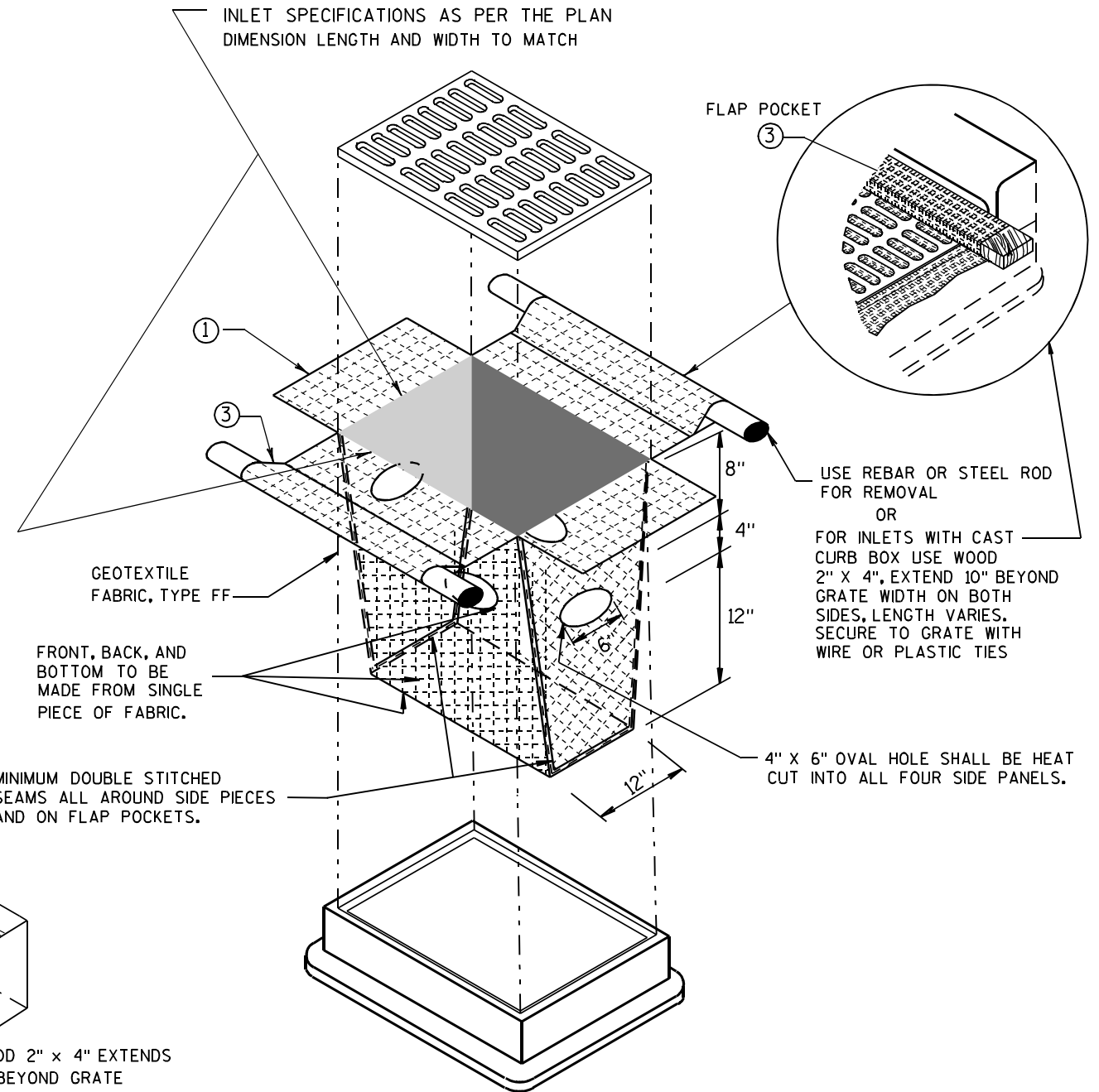

INLET PROTECTION, TYPE D

(CAN BE INSTALLED IN ANY INLET TYPE WITH OR WITHOUT A CURB BOX AS PER NOTE ②)

**INLET PROTECTION
TYPE A, B, C, AND D**

STATE OF WISCONSIN
DEPARTMENT OF TRANSPORTATION

APPROVED
10/16/02 /S/ Beth Conestra
DATE
CHIEF ROADWAY DEVELOPMENT ENGINEER
FHWA

GENERAL NOTES

DETAILS OF CONSTRUCTION, MATERIALS AND WORKMANSHIP NOT SHOWN ON THIS DRAWING SHALL CONFORM TO THE PERTINENT REQUIREMENTS OF THE STANDARD SPECIFICATIONS AND THE APPLICABLE SPECIAL PROVISIONS.

TRACKING PAD SHALL BE INSPECTED DAILY. DEFICIENT AREAS SHALL BE REPAIRED OR REPLACED IMMEDIATELY.

TRACKING PAD TO BE REMOVED AFTER CONSTRUCTION IS COMPLETED.

TRACKING PAD SHALL BE THE FULL WIDTH OF THE EGRESS POINT.

SURFACE WATER MUST BE PREVENTED FROM PASSING THROUGH THE TRACKING PAD. FLOWS SHALL BE DIVERTED AWAY, AROUND OR CONVEYED UNDER THE TRACKING PAD.

CULVERT PIPE OR OTHER BMP USED TO DIVERT WATER AWAY, AROUND OR UNDER THE TRACKING PAD SHALL BE DESIGNED TO CONVEY THE 2 YEAR - 24 HOUR EVENT.

THE COST OF ADDITIONAL BMP TO DIVERT WATER ARE INCIDENTAL TO THE TRACKING PAD BID ITEM.

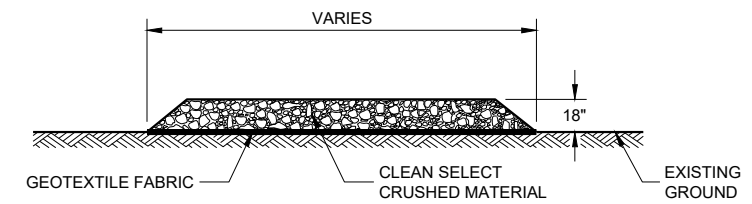

SECTION A - A

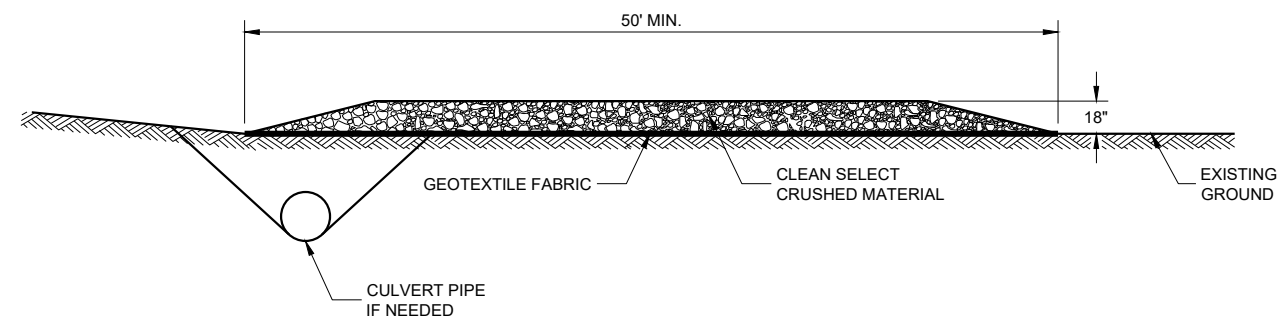
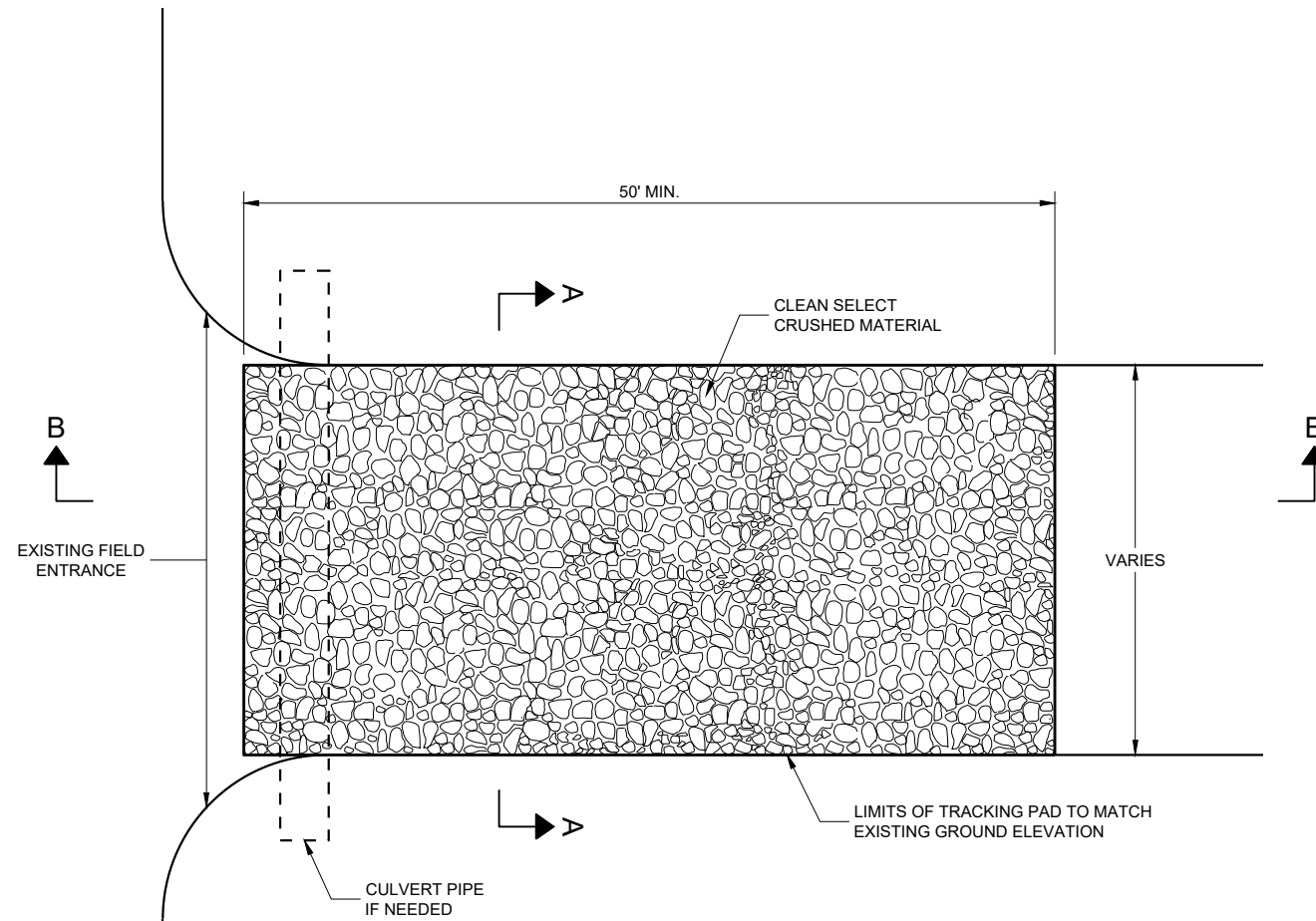

SECTION B - B

TRACKING PAD

STATE OF WISCONSIN
DEPARTMENT OF TRANSPORTATION

APPROVED
3/24/2011 DATE /S/ Jerry H. Zogg
ROADWAY STANDARDS DEVELOPMENT ENGINEER

FHWA

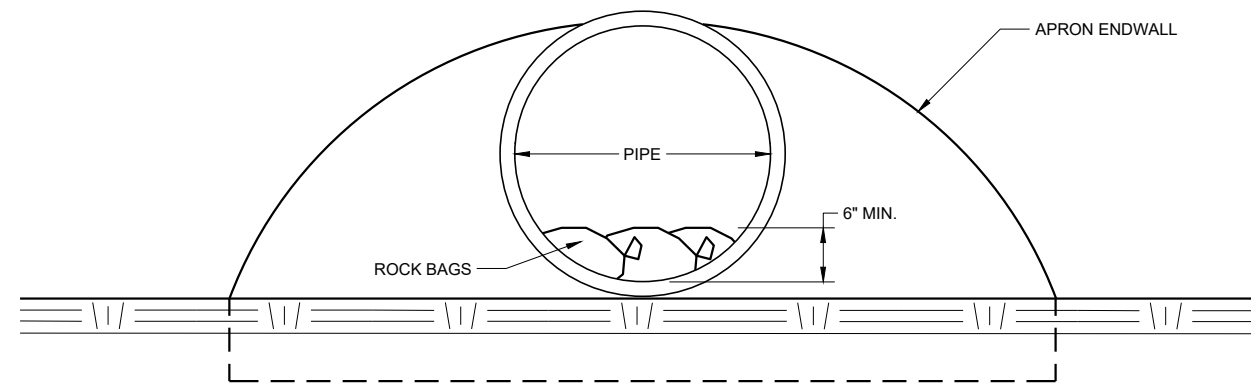

END VIEW

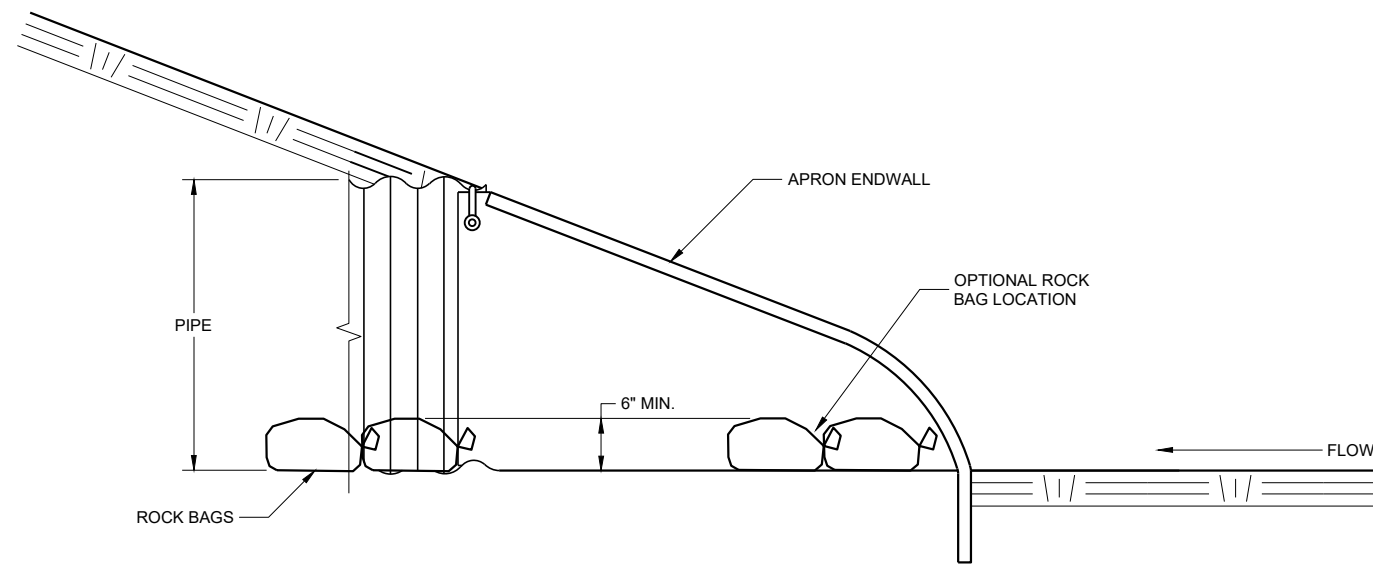

SIDE VIEW

CULVERT PIPE CHECK
(INSTALL ON INLET END ONLY)

CULVERT PIPE CHECK

STATE OF WISCONSIN
DEPARTMENT OF TRANSPORTATION

APPROVED
May 2019 /S/ Daniel Schave
DATE EROSION CONTROL ENGINEER

FHWA

METAL APRON ENDWALLS											
PIPE DIA. (IN.)	MIN. THICK. (Inches)		DIMENSIONS (Inches)						APPROX. SLOPE	BODY	
	STEEL	ALUM.	A (±1")	B (MAX.)	H (±1")	L (±1 1/2")	L1 ①	L2 ①			W (±2")
12	.064	.060	6	6	6	21	12	17 1/2	24	2 1/2 to 1	1 Pc.
15	.064	.060	7	8	6	26	14	21 3/4	30	2 1/2 to 1	1 Pc.
18	.064	.060	8	10	6	31	15	28 1/4	36	2 1/2 to 1	1 Pc.
21	.064	.060	9	12	6	36	18	29 5/8	42	2 1/2 to 1	1 Pc.
24	.064	.075	10	13	6	41	18	37 1/4	48	2 1/2 to 1	1 Pc.
30	.079	.075	12	16	8	51	18	52 1/4	60	2 1/2 to 1	1 Pc.
36	.079	.105	14	19	9	60	24	59 3/4	72	2 1/2 to 1	2 Pc.
42	.109	.105	16	22	11	69	24	75 5/8	84	2 1/2 to 1	2 Pc.
48	.109	.105	18	27	12	78	24	81	90	2 1/4 to 1	3 Pc.
54	.109	.105	18	30	12	84	30	85 1/2	102	2 1/4 to 1	3 Pc.
60	.109x	.105x	18	33	12	87	—	—	114	2 to 1	3 Pc.
66	.109x	.105x	18	36	12	87	—	—	120	2 to 1	3 Pc.
72	.109x	.105x	18	39	12	87	—	—	126	2 to 1	3 Pc.
78	.109x	.105x	18	42	12	87	—	—	132	1 1/2 to 1	3 Pc.
84	.109x	.105x	18	45	12	87	—	—	138	1 1/2 to 1	3 Pc.
90	.109x	.105x	18	37	12	87	—	—	144	1 1/2 to 1	3 Pc.
96	.109x	.105x	18	35	12	87	—	—	150	1 1/2 to 1	3 Pc.

* EXCEPT CENTER PANEL SEE GENERAL NOTES

REINFORCED CONCRETE APRON ENDWALLS									
PIPE DIA. (IN.)	DIMENSIONS (Inches)							APPROX. SLOPE	
	T	A	B	C	D	E	G		
12	2	4	24	48 1/8	72 1/8	24	2	3 to 1	
15	2 1/4	6	27	46	73	30	2 1/4	3 to 1	
18	2 1/2	9	27	46	73	36	2 1/2	3 to 1	
21	2 3/4	9	36	37 1/2	73 1/2	42	2 3/4	3 to 1	
24	3	9 1/2	43 1/2	30	73 1/2	48	3	3 to 1	
27	3 1/4	10 1/2	49 1/2	24	73 1/2	54	3 1/4	3 to 1	
30	3 1/2	12	54	19 3/4	73 1/2	60	3 1/2	3 to 1	
36	4	15	63	34 3/4	97 3/4	72	4	3 to 1	
42	4 1/2	21	63	35	98	78	4 1/2	3 to 1	
48	5	24	72	26	98	84	5	3 to 1	
54	5 1/2	27	65	33 1/4-35	98 1/4-100	90	5 1/2	2 1/2 to 1	
60	6	30-35	60	39	99	96	5	2 to 1	
66	6 1/2	24-30	72-78	21-27	99	102	5 1/2	2 to 1	
72	7	24-36	78	21	99	108	6	2 to 1	
78	7 1/2	24-36	78	21	99	114	6 1/2	2 to 1	
84	8	36	90 1/2	21	111 1/2	120	6 1/2	1 1/2 to 1	
90	8 1/2	41	87 1/2	24	111 1/2	132	6 1/2	1 1/2 to 1	

*MINIMUM
**MAXIMUM

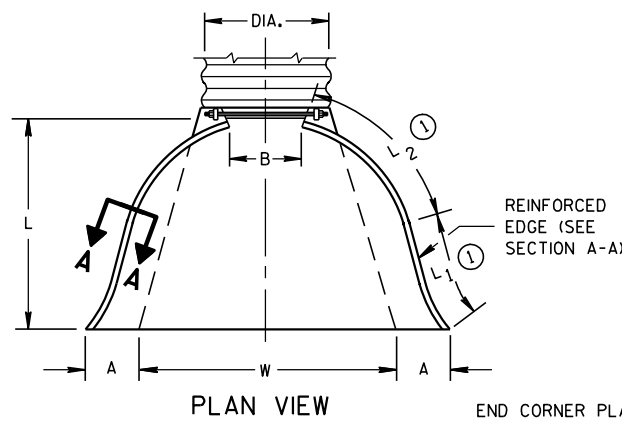

REINFORCED EDGE (SEE SECTION A-A)
END CORNER PLATES MAY BE FASTENED TO APRON PROPER BY BOLTS, RIVETS, OR RESISTANCE SPOT WELDS WHICH WILL HOLD THE SURFACES TIGHTLY TOGETHER

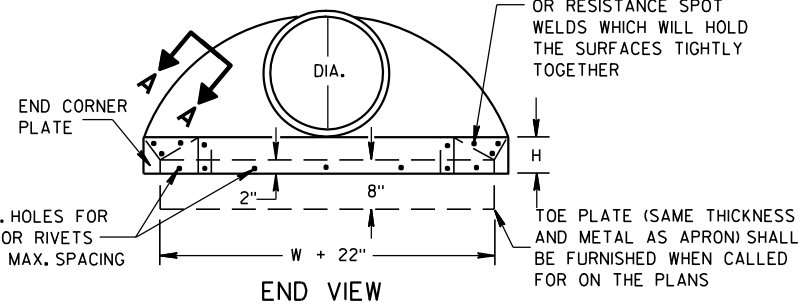

SIDE ELEVATION METAL ENDWALLS

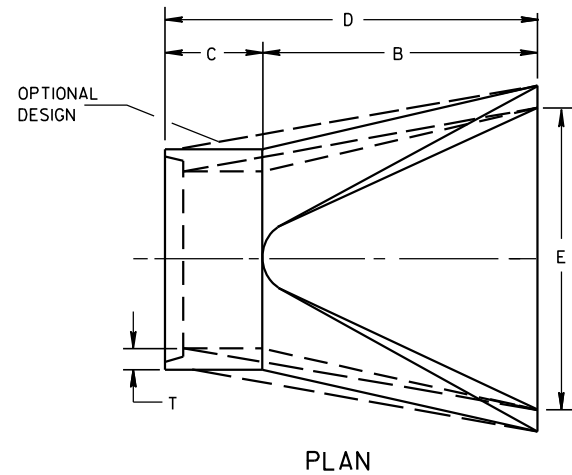

PLAN

END VIEW

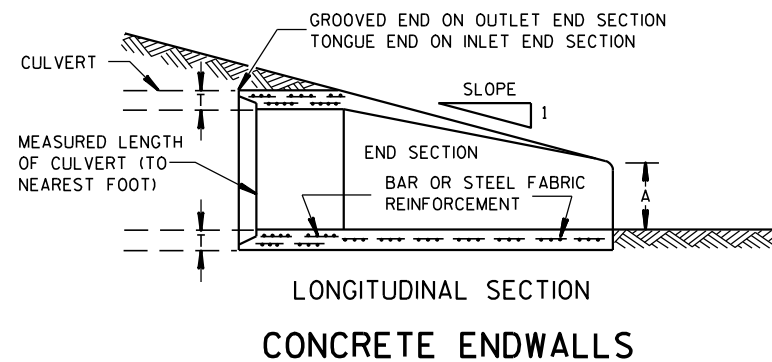

LONGITUDINAL SECTION CONCRETE ENDWALLS

1" WIDE, 12 GA. (0.109" THICK) GALVANIZED STRAP WITH STANDARD 6" X 1/2" BAND BOLT AND NUT

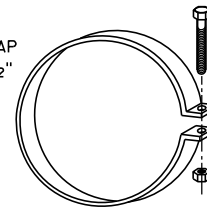

ALTERNATE FOR TYPE 1 CONNECTION END SECTION CONNECTOR STRAP

THREADED 1/8" DIA. ROD AROUND CULVERT & THROUGH TANK TYPE CONNECTOR LUG OR ALTERNATE CONNECTOR STRAP (SEE DETAIL)

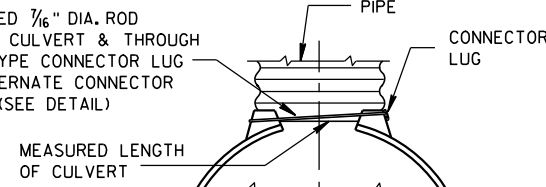

TYPE 1 FOR 12" THRU 24" CORR. PIPE

THREADED 1/8" DIA. ROD OVER TOP OF APRON, SIDE LUGS TO BE RIVETED TO APRON

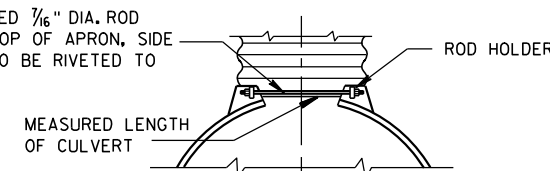

TYPE 2 FOR 30" THRU 96" CORR. PIPE

MEASURED LENGTH OF CULVERT
CONNECTOR SECTION TO BE PAID FOR AS PART OF END SECTION

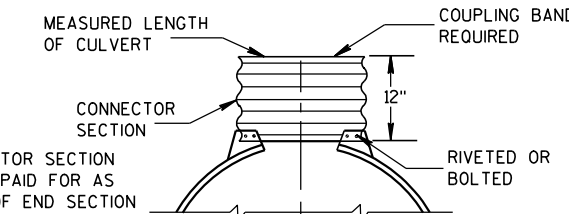

TYPE 3 FOR 42" THRU 96" CORR. PIPE

DIMPLED OR CORRUGATED COUPLING BAND
RIVETED OR BOLTED AT DIMPLES (6" C-C FOR CORRUGATED BAND)

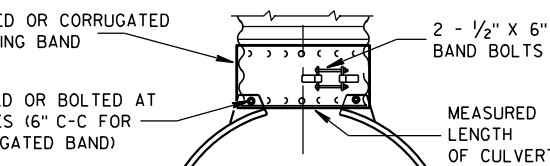

TYPE 5 ALTERNATE FOR: ALL SIZES CORRUGATED CIRCULAR PIPE

NOTE: DIMPLED BAND FITS OVER OUTSIDE OF ENDWALL, AND CORRUGATED BAND FITS INSIDE ENDWALL. DIMPLED BAND MAY BE USED WITH HELICALLY CORRUGATED PIPE.

FOR CIRCUMFERENTIALLY CORRUGATED PIPE USE ENDWALL CONNECTION DETAILS 1, 2, 3 OR 5 AS APPLICABLE.

FOR HELICALLY CORRUGATED PIPE USE ENDWALL CONNECTION DETAILS 1, 2 OR 5.

FOR HELICALLY CORRUGATED PIPES WITH TWO CIRCUMFERENTIAL CORRUGATIONS AT EACH END USE ENDWALL CONNECTION DETAILS 1, 2 OR 3.

CONNECTION DETAILS

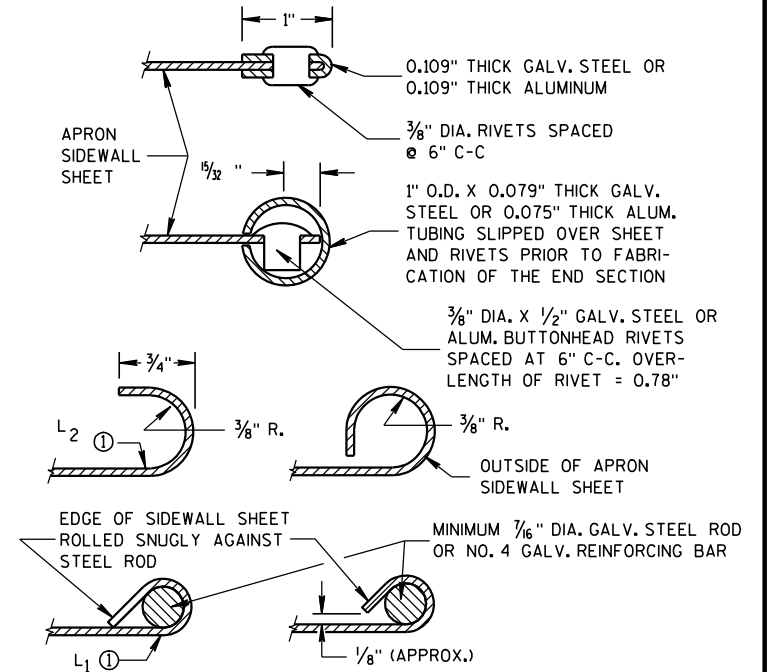

SECTION A-A

GENERAL NOTES

DETAILS OF CONSTRUCTION, MATERIALS AND WORKMANSHIP NOT SHOWN ON THIS DRAWING SHALL CONFORM TO THE PERTINENT REQUIREMENTS OF THE STANDARD SPECIFICATIONS AND THE APPLICABLE SPECIAL PROVISIONS.

CONCRETE CULVERT ENDWALLS MAY NOT BE USED WITH GALVANIZED STEEL OR ALUMINUM CULVERT PIPE OR VICE VERSA. GALVANIZED STEEL OR ALUMINUM ENDWALLS SHALL NORMALLY BE INSTALLED ON CULVERT PIPE OF THE SAME METAL.

ALL THREE PIECE STEEL APRON ENDWALLS FOR 60" DIAMETER PIPE AND LARGER SHALL HAVE 0.109" SIDES AND 0.138" CENTER PANELS. ALL THREE PIECE ALUMINUM APRON ENDWALLS FOR 60" DIAMETER PIPE AND LARGER SHALL HAVE 0.105" SIDES AND 0.134" CENTER PANELS. THE WIDTH OF CENTER PANELS SHALL BE GREATER THAN 20 PERCENT OF THE PIPE PERIMETER.

LAP SEAMS SHALL BE TIGHTLY JOINED BY GALVANIZED RIVETS OR BOLTS FOR STEEL UNITS AND ALUMINUM RIVETS AND BOLTS FOR ALUMINUM UNITS. FOR THE 60" THROUGH 96" DIAMETER APRON ENDWALL SIZES, THE REINFORCED EDGES AND CENTER PANEL SEAMS SHALL BE FURTHER REINFORCED WITH GALVANIZED STEEL OR ALUMINUM STIFFENER ANGLES. THE ANGLES SHALL BE ATTACHED BY GALVANIZED NUTS AND BOLTS FOR STEEL UNITS AND ALUMINUM NUTS AND BOLTS FOR ALUMINUM UNITS.

WHERE TWO OR MORE PIPES WITH APRON ENDWALLS ARE LAID ADJACENT TO EACH OTHER, THEY SHALL BE SEPARATED BY A DISTANCE SUFFICIENT TO PROVIDE A MINIMUM CLEARANCE OF 6 INCHES BETWEEN APRON ENDWALLS.

① FOR PIPE SIZES UP TO 60" DIAMETER, A 180° ROLLED EDGE MAY BE USED INSTEAD OF STEEL ROD REINFORCEMENT. SEE SECTION A-A.

APRON ENDWALLS FOR CULVERT PIPE

STATE OF WISCONSIN DEPARTMENT OF TRANSPORTATION

APPROVED 11/30/94 DATE /S/ Rory L. Rhinesmith CHIEF ROADWAY DEVELOPMENT ENGINEER
FHWA

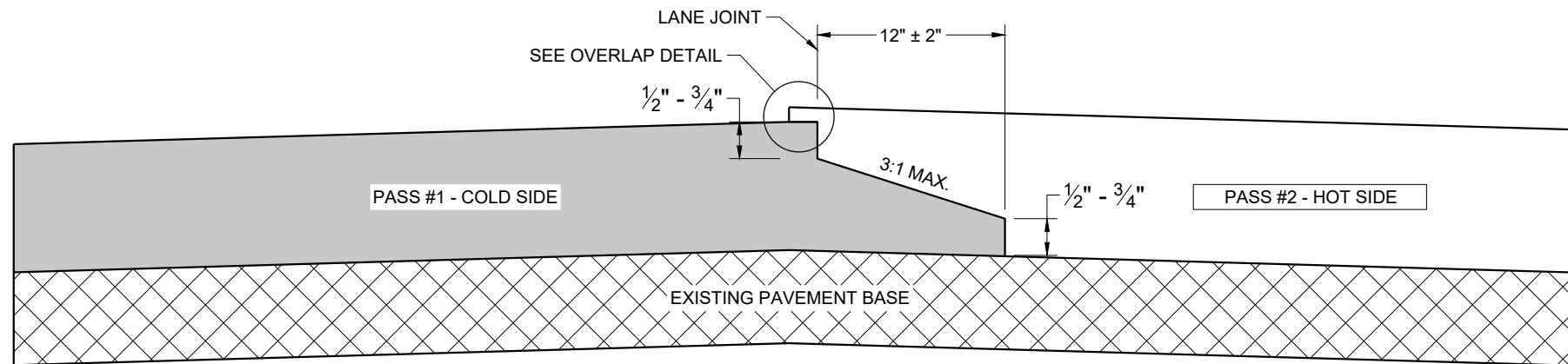

TYPICAL PAVEMENT CROSS SECTION NOTCHED WEDGE JOINT

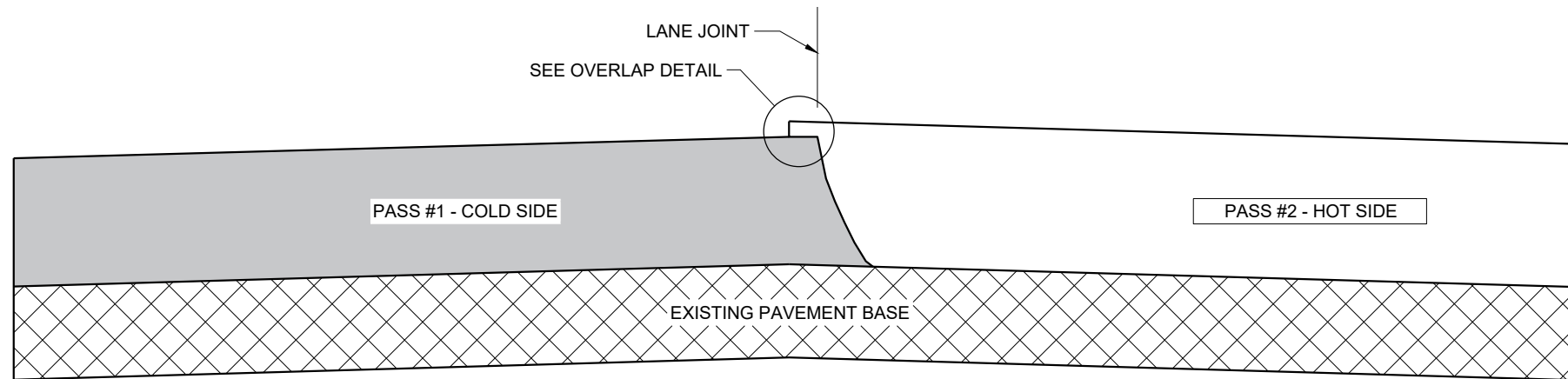

TYPICAL PAVEMENT CROSS SECTION VERTICAL JOINT

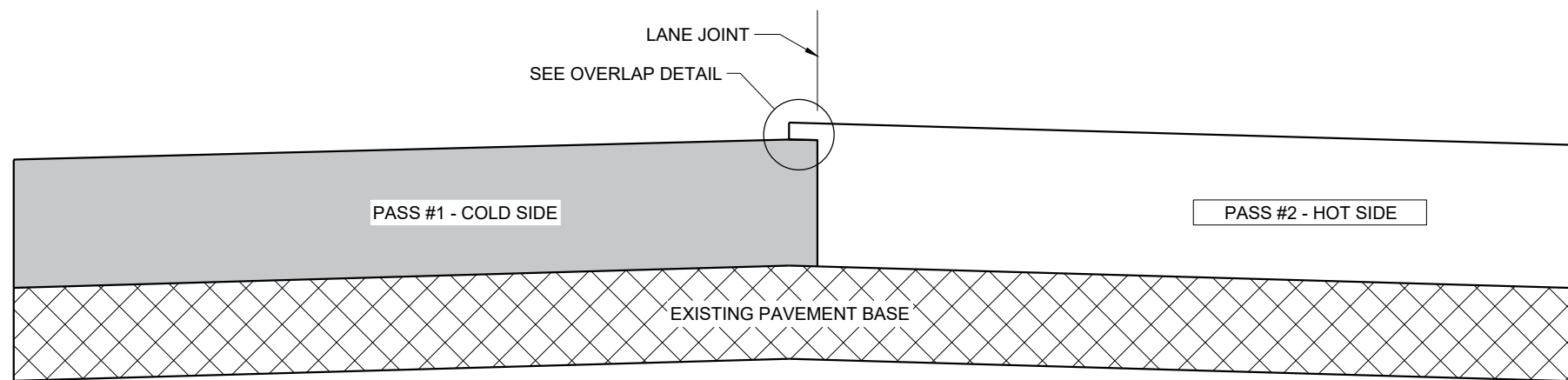

TYPICAL PAVEMENT CROSS SECTION VERTICAL JOINT (MILLED)

GENERAL NOTES

IN ADDITION TO THE DETAILS PROVIDED IN THIS DRAWING, CONFORM TO STANDARD SPECIFICATION 450.3.2.8 FOR WHEN A NOTCHED WEDGE JOINT IS REQUIRED AND FOR GENERAL JOINT CONSTRUCTION REQUIREMENTS.

FOR ALL LONGITUDINAL JOINTS, ENSURE THE PAVER SCREED OVERLAPS THE PREVIOUSLY PLACED PAVEMENT BY $1" \pm 0.5"$ AND THE HOT SIDE OF THE JOINT REMAINS HIGHER THAN THE COLD SIDE BY APPROXIMATELY 0.1" AFTER FINAL COMPACTION. (IT WILL BE FLUSH WHEN PAVING IN ECHELON.)

ONLY REMOVE THE LONGITUDINAL NOTCHED WEDGE JOINT FOR SMA PAVEMENT OR AS DIRECTED BY THE ENGINEER TO ADDRESS SPECIFIC LENGTHS OF JOINT DAMAGED BY TRAFFIC.

WHEN MILLING BACK OR REMOVING ANY LONGITUDINAL JOINT, LIMIT THE MATERIAL REMOVED TO 2" FROM THE TOP NOTCH OR FROM THE VERTICAL JOINT EDGE ON THE COLD SIDE OF THE JOINT.

USE LONGITUDINAL MILLED JOINT AS PLANS SHOW OR THE AS THE ENGINEER DIRECTS.

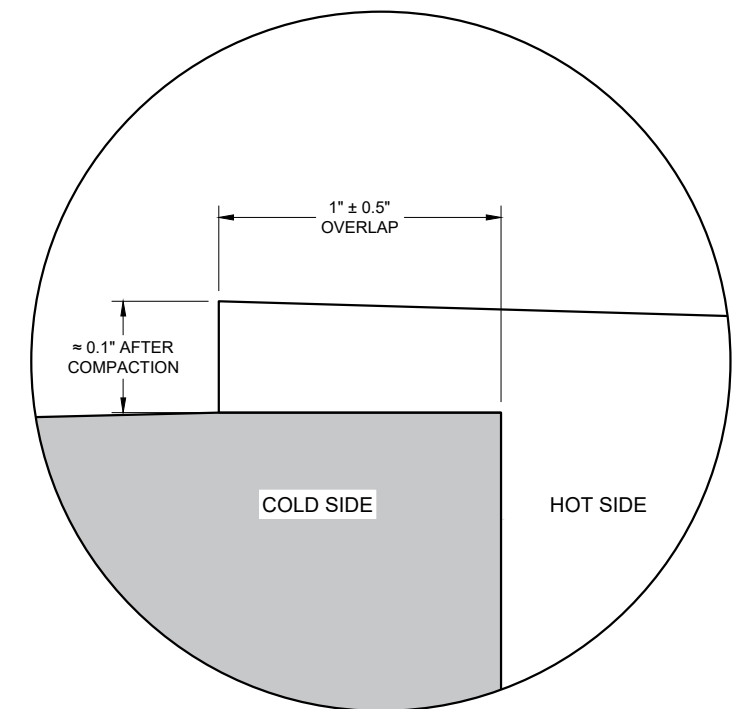

OVERLAP DETAIL (TYPICAL)

6

6

SDD 13C19 - 03

SDD 13C19 - 03

HMA LONGITUDINAL JOINTS	
STATE OF WISCONSIN DEPARTMENT OF TRANSPORTATION	
APPROVED November 2020 DATE	/S/ Steven Hefel HMA PAVEMENT ENGINEER
FHWA	

- ① WOOD OR STEEL POSTS (w6X9 OR w6X8.5) MAY BE USED. DO NOT INTERMIX WOOD AND STEEL POSTS. INSTALL STEEL POSTS WITH HOLES ON APPROACHING TRAFFIC SIDE.
- ② USE WOOD OR APPROVED PLASTIC BLOCKOUTS. WOOD BLOCKOUTS MAY BE CONSTRUCTED OUT OF TWO OR MORE WOOD BLOCKOUTS. SEE ALTERNATE WOOD BLOCKOUT DETAIL. DIMENSIONS OF APPROVED PLASTIC BLOCKOUTS MAY VARY.
- ③ IF ROCK IS ENCOUNTERED DURING EXCAVATION, PROVIDE A HOLE 12 INCHES IN DIAMETER EXTENDING 20 INCHES DEEP INTO THE ROCK. PLACE APPROXIMATELY 2 1/2" INCHES OF GRANULAR MATERIAL IN THE BOTTOM OF THE HOLE. CUT THE POSTS THE TO LENGTH AND INSTALL. BACKFILL WITH EXCAVATED MATERIAL AND COMPACT. BACKFILL IS TO BE FREE OF LARGE ROCKS.
- ④ WHEN THE DISTANCE FROM BACK OF POST TO SHOULDER HINGE POINT IS LESS THAN 2 FEET INSTALL LONGER POST AT HALF POST SPACING (K).
- ⑤ FOR NEW MGS INSTALLATION TOP OF W-BEAM RAIL TOLERANCE IS ±1". FOR EXISTING MGS INSTALLATION TOP OF W-BEAM IS BETWEEN 27 3/4" TO 32".
- ⑥ WHEN USING STEEL POST AND WOOD BLOCKOUTS INSTALL FOUR 16D GALVANIZED NAILS. INSTALL NAILS AT THE BACK CORNERS OF THE BLOCK AND BEND THE NAILS OVER THE FLANGE OF THE STEEL POST.
- ⑦ TOTAL POST LENGTH FOR TYPE K IS 7' - 0". TOTAL POST LENGTH FOR OTHER MGS TYPES IS 6' - 0".

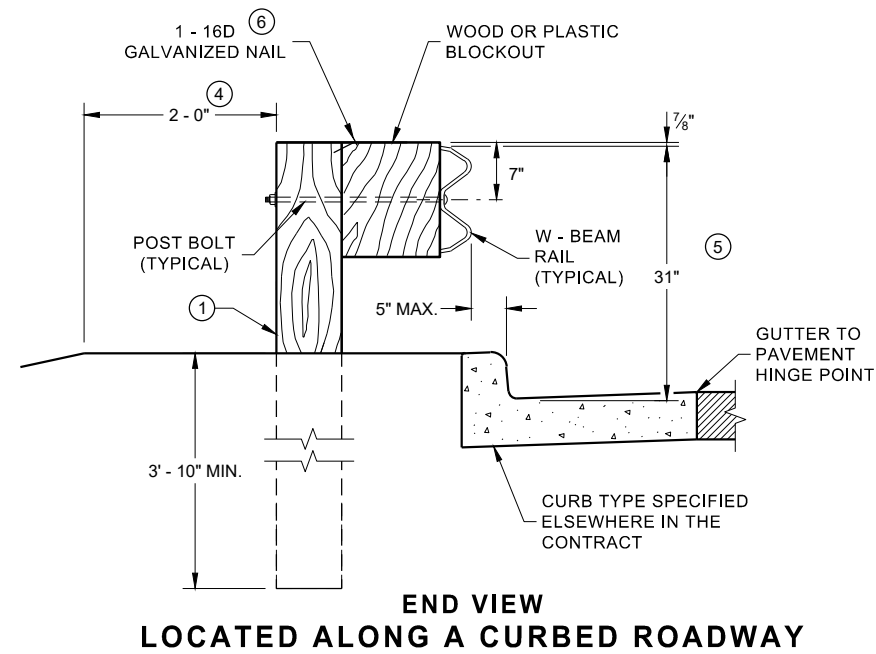
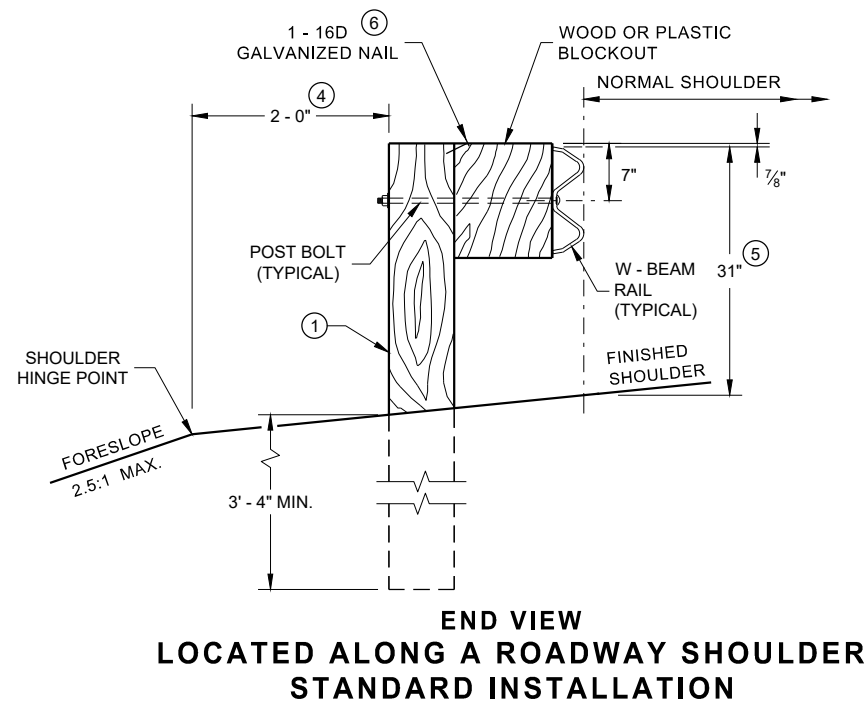
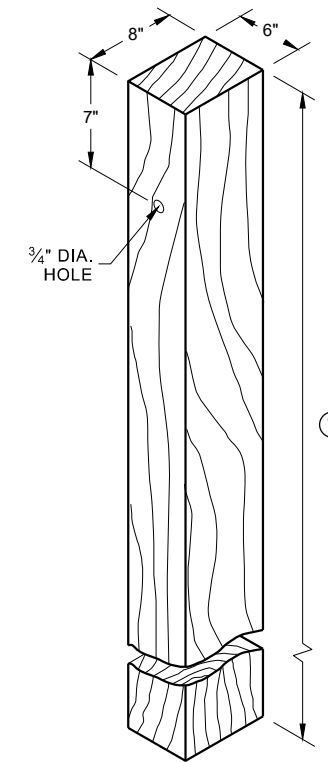
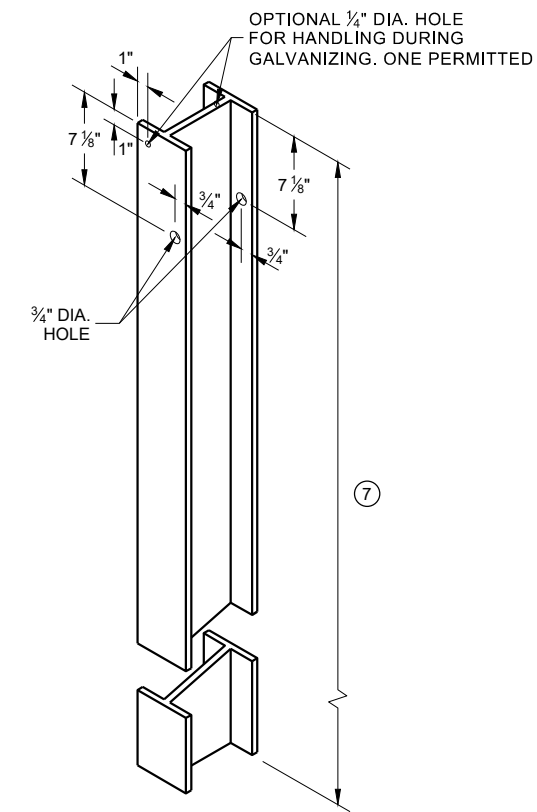
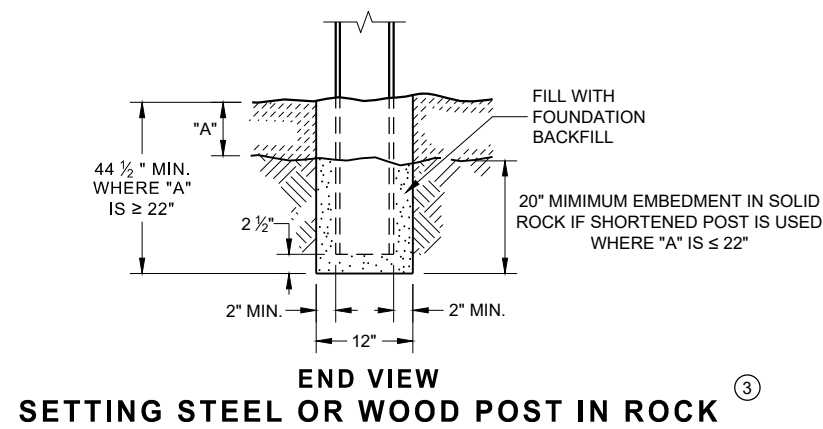

STEEL POST & HOLE PUNCHING DETAIL (W 6 X 9)

WOOD POST (6" X 8") NOMINAL

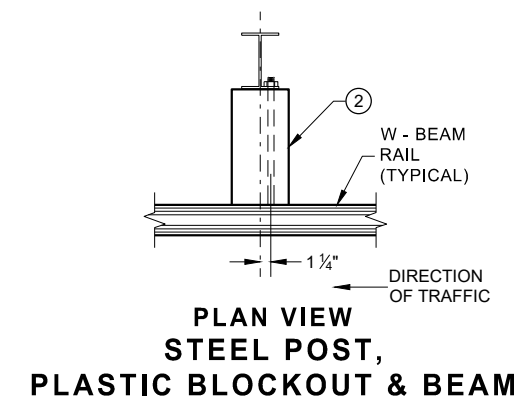
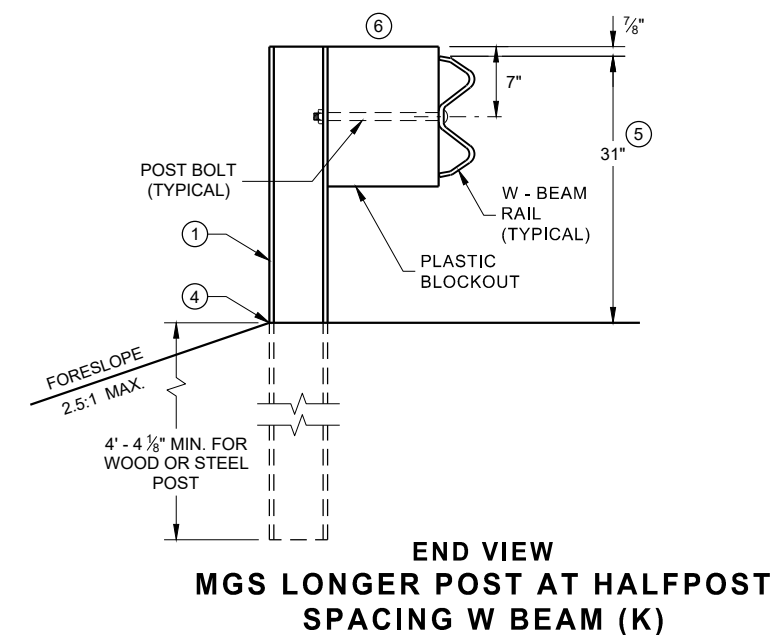
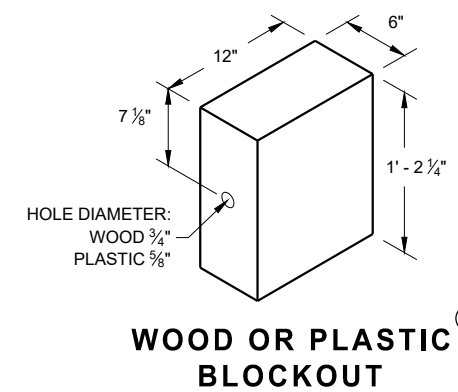
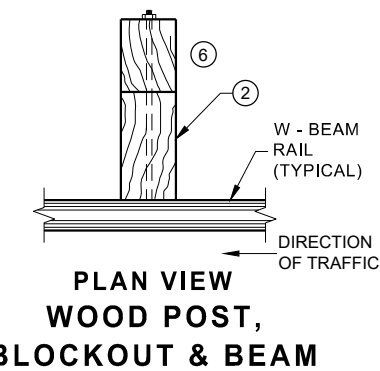

MIDWEST GUARDRAIL SYSTEM (MGS) GUARDRAIL

STATE OF WISCONSIN
DEPARTMENT OF TRANSPORTATION

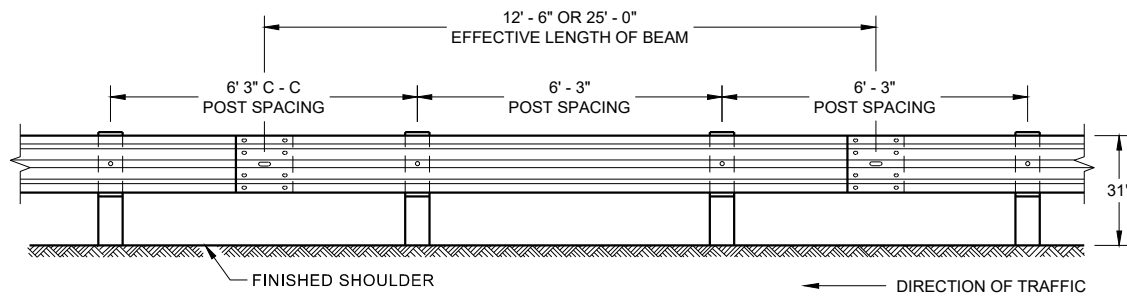

**FRONT VIEW
POST SPACING STANDARD INSTALLATION**

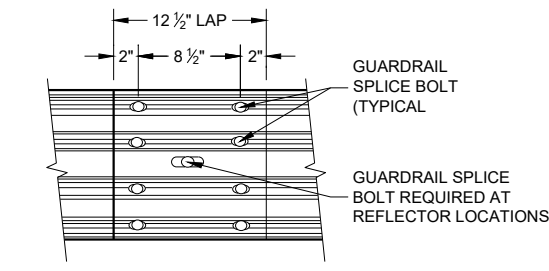

**FRONT VIEW
MID-SPAN BEAM SPLICE**

GENERAL NOTES

- ⑧ DO NOT INSTALL REFLECTORS ON THE FIRST 50 FEET OF THE APPROACH END OF THE ENERGY ABSORBING TERMINAL.
 - ⑨ 25 FEET OF HALF POST SPACING IS REQUIRED ON APPROACH AND DEPARTURE ENDS OF QUARTER POST SPACING.
- POST BOLTS ARE A 3/8" DIAMETER ASTM A307 GUARDRAIL BOLT. A POST BOLT REQUIRES 3/4" DIAMETER A563A DOUBLE RECESSED (DR) HEAVY HEX NUT AND 3/8" DIAMETER F844 FLAT WASHER. POST BOLTS MAY BE LONGER IF MULTIPLE BLOCKOUTS ARE BEING USED.
- GUARD RAIL SPLICE BOLTS ARE A 3/8" DIAMETER ASTM A307 GUARDRAIL HEAD BOLT. A GUARDRAIL SPLICE BOLT REQUIRES 3/8" DIAMETER A563A DOUBLE RECESSED (DR) HEAVY HEX NUT.

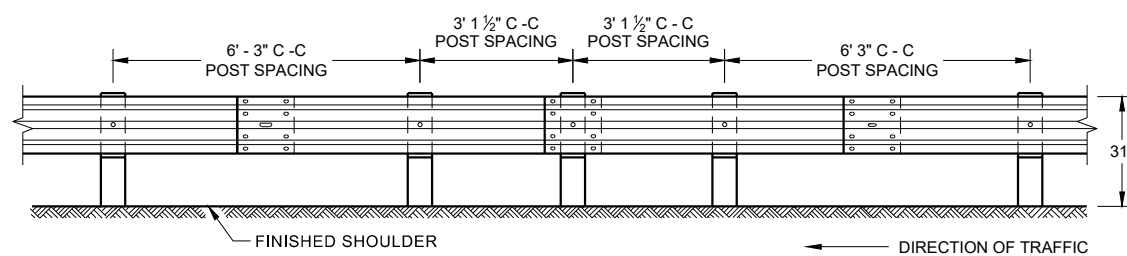

**FRONT VIEW
HALF POST SPACING (HS) AND
HALF POST SPACING WITH LONGER POSTS (K)**

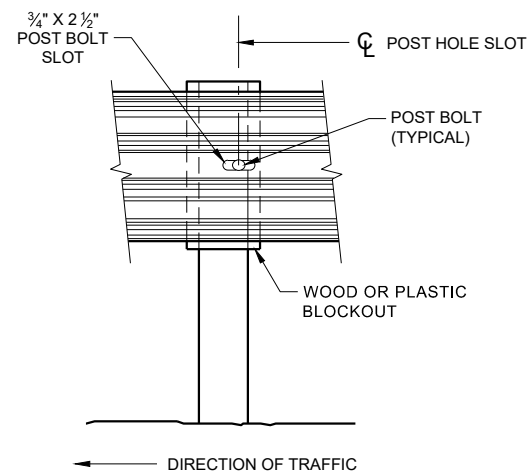

FRONT VIEW AT STEEL POST

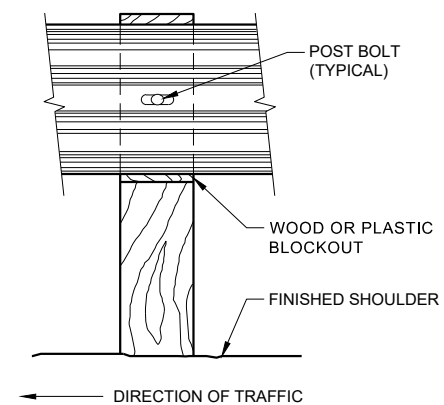

FRONT VIEW AT WOOD POST

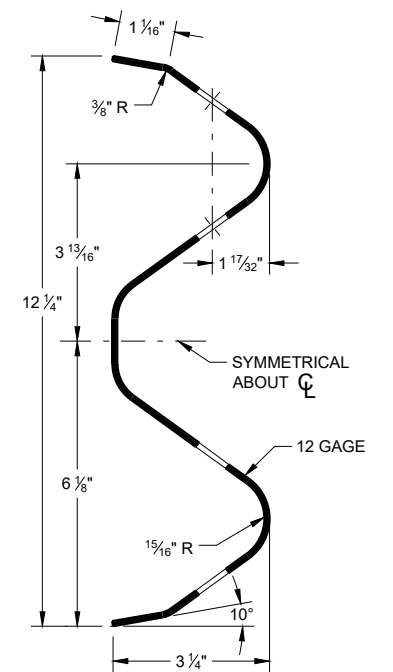

SECTION THRU W-BEAM RAIL

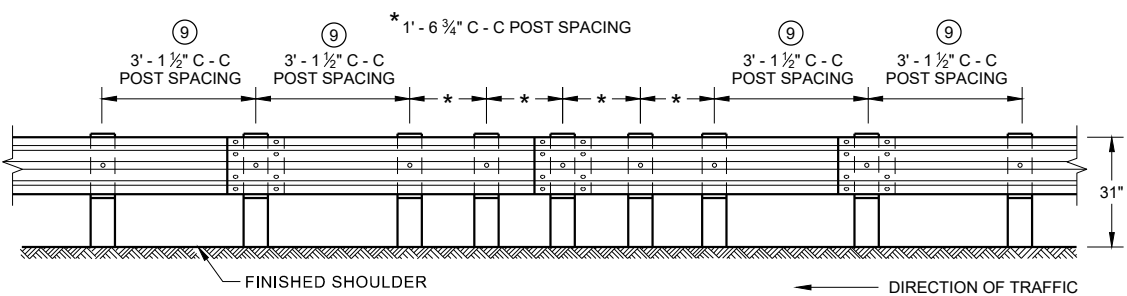

**FRONT VIEW
QUARTER POST SPACING (QS)**

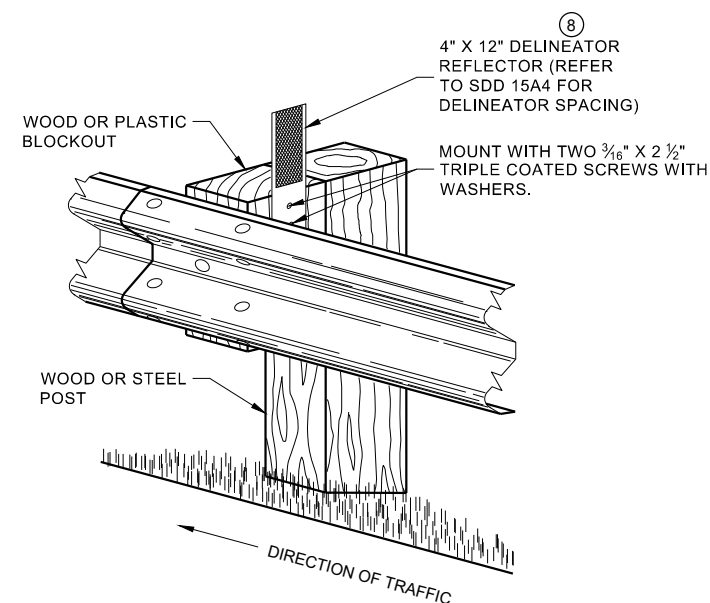

**ONE SIDED REFLECTOR DETAIL
AND TYPICAL INSTALLATION**

**MIDWEST GUARDRAIL SYSTEM
(MGS) GUARDRAIL**

STATE OF WISCONSIN
DEPARTMENT OF TRANSPORTATION

6

6

SDD 14B42 - 07b

SDD 14B42 - 07b

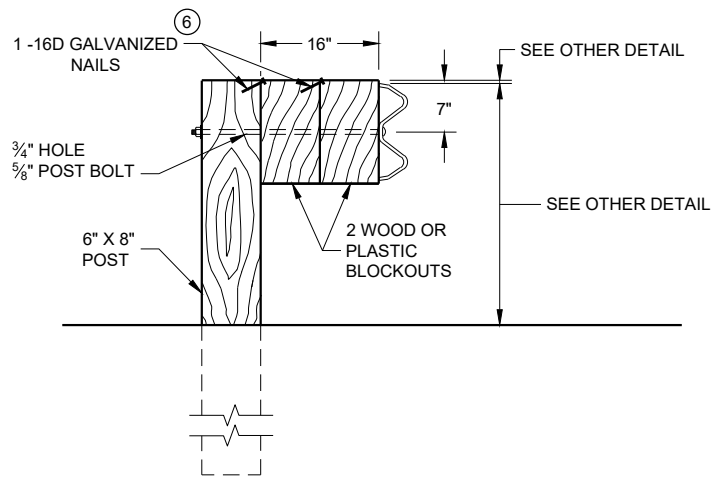

DETAIL FOR 16" BLOCKOUT DEPTH

IT IS ACCEPTABLE TO USE BLOCKOUTS UP TO 16" DEEP TO INCREASE THE POST OFFSET TO AVOID UNDERGROUND OBSTACLES. THERE IS NO LIMIT TO THE NUMBER OF POSTS THAT CAN HAVE ADDITIONAL BLOCKOUTS UP TO 16" DEEP.

NOTE:

1. ALL FILLETS SHALL HAVE A MINIMUM RADIUS OF 3/16".
2. IF THE BOLT EXTENDS MORE THAN 1/4" FROM THE NUT THE BOLT SHOULD BE TRIMMED BACK.

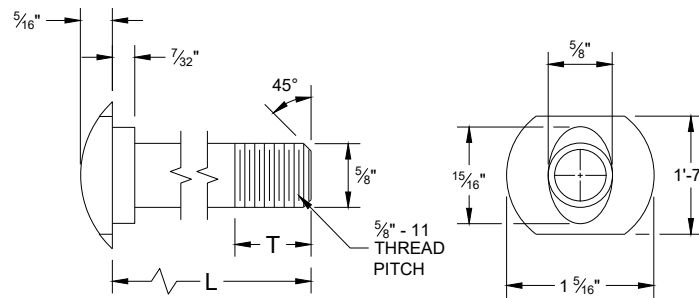

POST BOLT TABLE

L	T (MIN.)
1 1/4"	1 1/8"
2"	1 3/4"
10"	4"
14"	4 1/16"
18"	4"
21"	4 1/16"
25"	4"

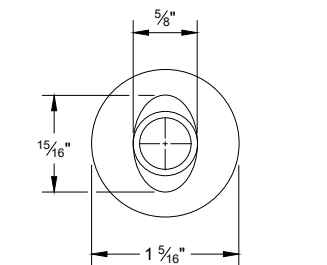

ALTERNATE BOLT HEAD

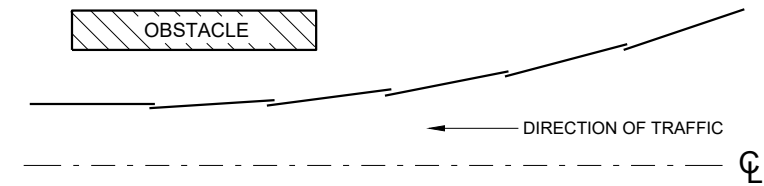

**PLAN VIEW
BEAM LAPPING DETAIL**

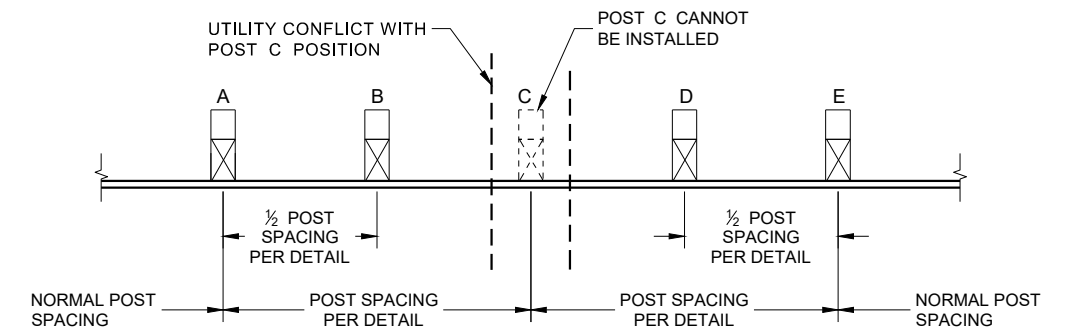

**POST DRIVING FOR CONTINUOUS
UNDERGROUND OBSTRUCTION**

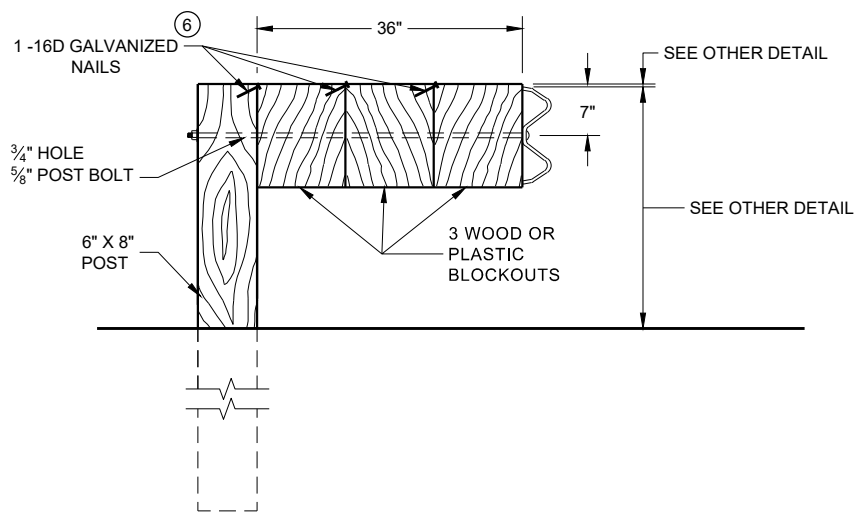

DETAIL FOR 36" BLOCKOUT DEPTH

NOTES: UNDER SPECIAL CIRCUMSTANCES, SUCH AS AVOIDING OBSTACLES THAT ARE NOT RELOCATED, IT IS ACCEPTABLE TO INSTALL ADDITIONAL BLOCKOUTS TO OBTAIN UP TO 36" DEPTH FOR ONE OR TWO POSTS IN A SECTION OF GUARDRAIL.
DO NOT USE 16" OR 36" BLOCKOUTS IF IT CAUSES THE POST TO BE DRIVEN BEYOND SHOULDER HINGE POINT OR CAUSES A FIXED OBJECT TO BE WITHIN THE DEFLECTION DISTANCE OF THE BARRIER.

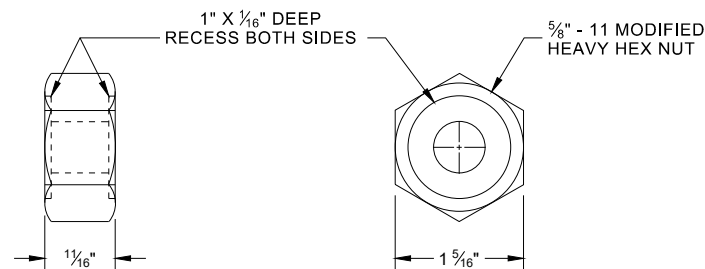

**POST BOLT, SPLICE BOLT
AND RECESS NUT**

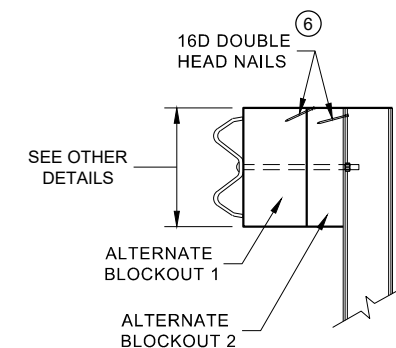

SIDE VIEW

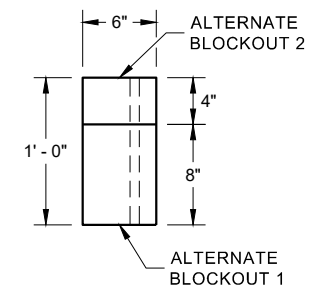

PLAN VIEW

**ALTERNATE WOOD
BLOCKOUT DETAIL**

6 WHEN USING STEEL POST AND WOOD BLOCKOUTS, INSTALL FOUR 16D GALVANIZED NAILS. INSTALL NAILS AT THE BACK CORNERS OF THE BLOCK AND BEND THE NAILS OVER THE FLANGE OF THE STEEL POST.

**MIDWEST GUARDRAIL SYSTEM
(MGS) GUARDRAIL**

STATE OF WISCONSIN
DEPARTMENT OF TRANSPORTATION

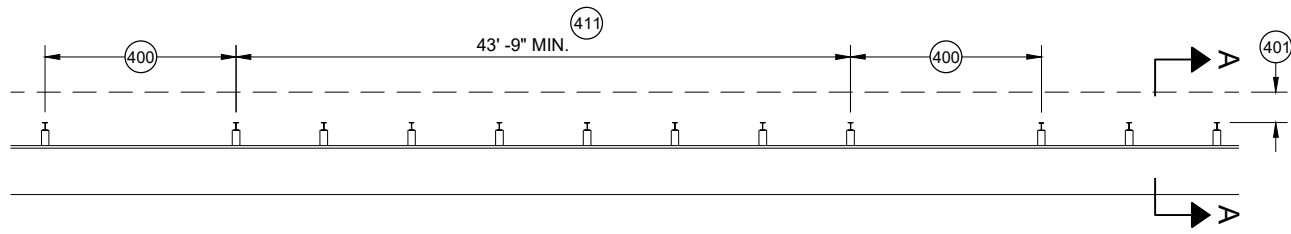

MISSING POST IN MGS GUARDRAIL

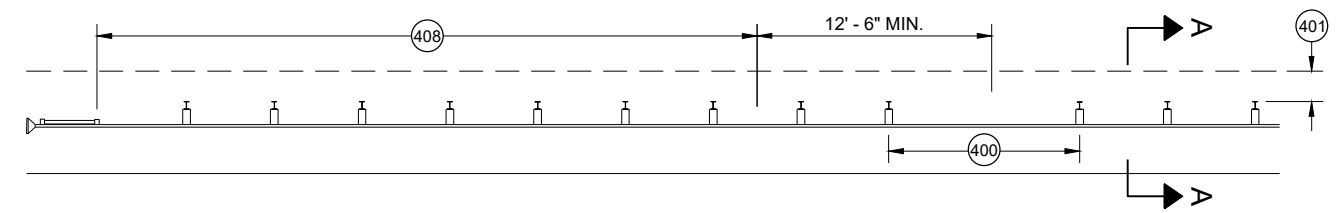

MISSING POST IN MGS GUARDRAIL NEAR EAT

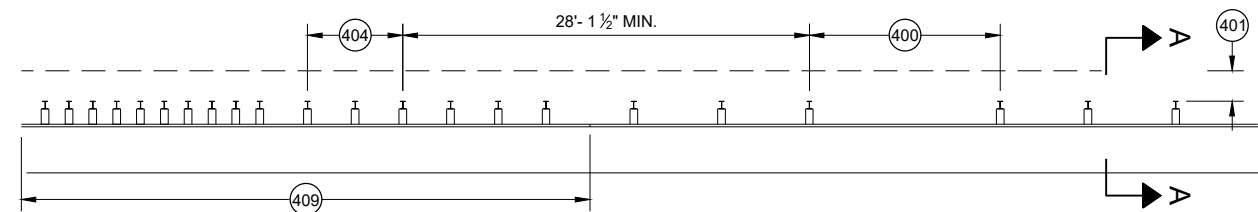

MISSING POST IN MGS GUARDRAIL NEAR AN APPROACH TRANSITION

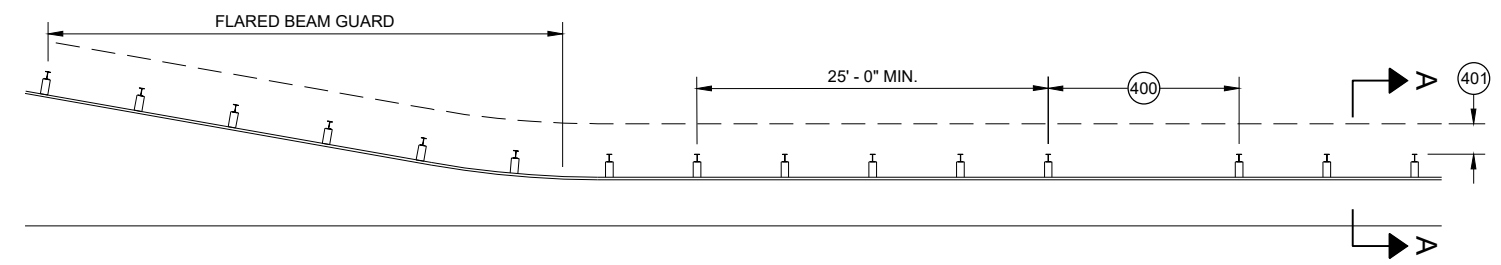

MISSING POST IN MGS GUARDRAIL NEAR FLARED BEAM GUARD

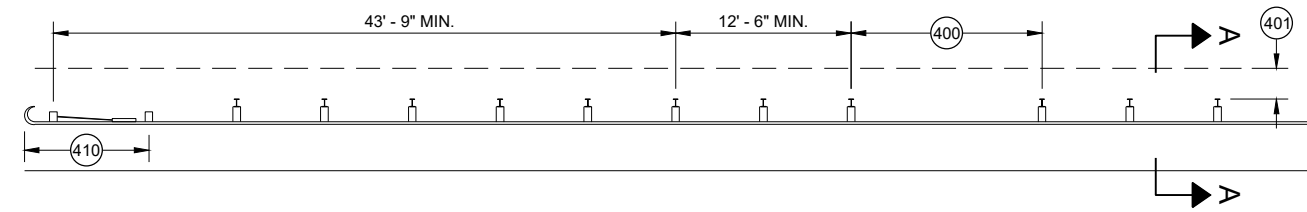

MISSING POST IN MGS GUARDRAIL NEAR A TYPE 2 END TERMINAL

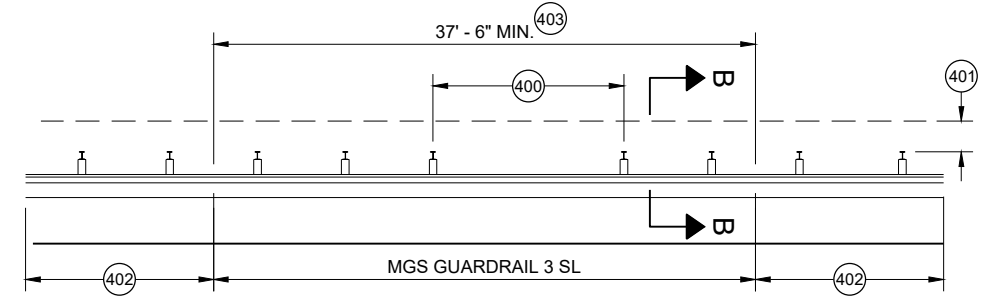

MISSING POST IN SHORT SPAN MGS GUARDRAIL NEAR CURB (SL)

- ④00 MAX SPAN 12' - 6"
- ④01 2' MIN.
- ④02 MGS GUARDRAIL 3
- ④03 NESTING BEAM GUARD
- ④04 ASYMMETRIC TRANSITION
- ④05 SOIL WELL DRAINED AND COMPACTED
- ④06 SEE OTHER DRAWINGS IN THIS SDD
- ④07 SEE OTHER DRAWINGS FOR MIN. SPACING BETWEEN SPANS
- ④08 SEE SDD 14B44
- ④09 SEE SDD 14B45
- ④10 SEE SDD 14B47
- ④11 MINIMUM DISTANCE BETWEEN MISSING POST SPANS.

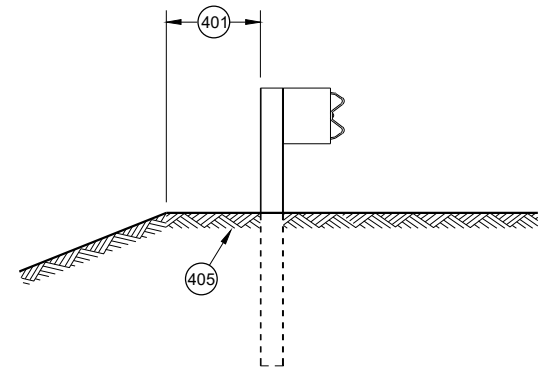

SECTION A - A

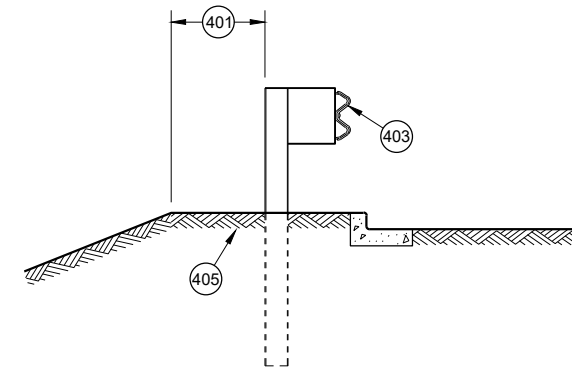

SECTION B - B

MIDWEST GUARDRAIL SYSTEM (MGS) GUARDRAIL	
STATE OF WISCONSIN DEPARTMENT OF TRANSPORTATION	
APPROVED May 2021 DATE	/S/ Rodney Taylor ROADWAY STANDARDS DEVELOPMENT UNIT SUPERVISOR
<small>FHWA</small>	

GENERAL NOTES

- (A) THE SLOPE IN THE AREA BOUNDED BY THE GRADELINE, THE HINGE POINT LINE AND THE CLEAR ZONE LIMITS (CZL) SHALL BE 4:1 OR FLATTER.
 - (B) AFTER FINAL ASSEMBLY, RECHECK CABLE TO BE SURE IT IS TAUT AND HAS NOT RELAXED
 - (C) DIFFERENT MANUFACTURERS REQUIRE DIFFERENT PERFORATED W - BEAM RAIL END PANELS. SEE MANUFACTURER'S INFORMATION.
 - (D) ATTACH ALUMINUM SHEET TO E.A.T. HEAD USING 4 STAINLESS STEEL SELF - TAPPING SCREWS. ONE SCREW PER CORNER.
 - (E) HARDWARE MAY VARY BETWEEN MANUFACTURER. SEE MANUFACTURER'S DRAWING FOR INFORMATION.
- DIMENSIONS MAY VARY, MANUFACTURER'S INFORMATION.

SEE SDD 14B42 FOR MORE INFORMATION.

* DO NOT ATTACH BLOCKOUTS TO POST 1 AND 2.

DO NOT INSTALL REFLECTORS ON THE FIRST 50 FEET OF THE APPROACH END OF THE ENERGY ABSORBING TERMINAL.

SEE MANUFACTURER'S DRAWING FOR SPLICE LOCATION, HARDWARE DIMENSIONS AND INSTALLATION INSTRUCTIONS.

THE CENTER OF THE UPPER 3 1/2" DIAMETER HOLE ON POST NUMBER 3 THROUGH POST 9 IS TO BE FLUSH WITH THE GROUND LINE UP TO A MAXIMUM OF 2" ABOVE GROUND LINE. WOOD BLOCKS ON POSTS NUMBERED 3 THROUGH 9 MAY BE ADJUSTED UP TO 3" ABOVE THE TOP OF POST.

CLEAR ZONE LIMITS, EITHER AS SHOWN ELSEWHERE IN THE PLANS OR, IF NOT SHOWN ELSEWHERE IN THE PLANS, 15 FEET BEYOND THE HINGE POINT LINE

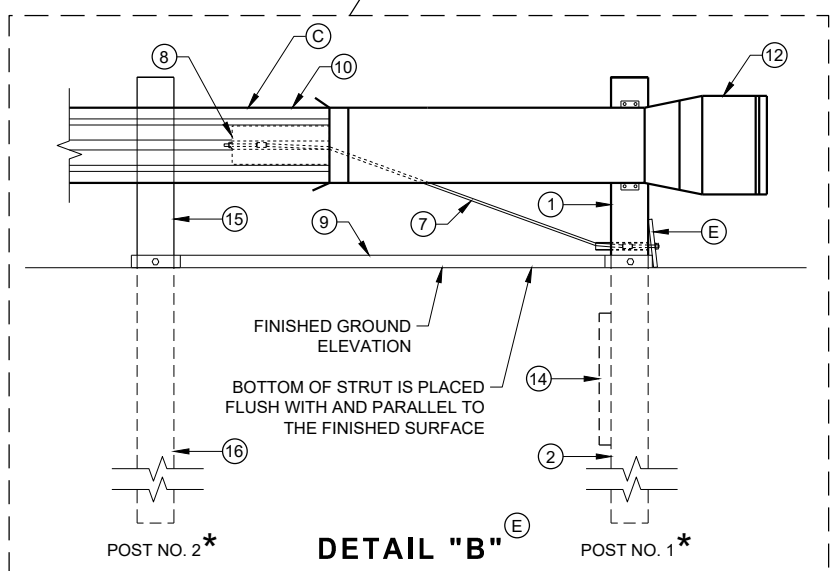
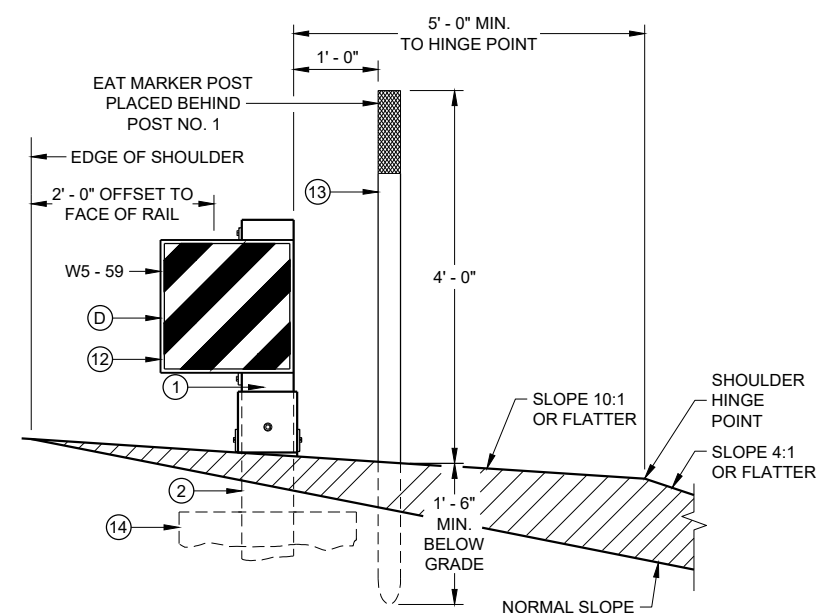
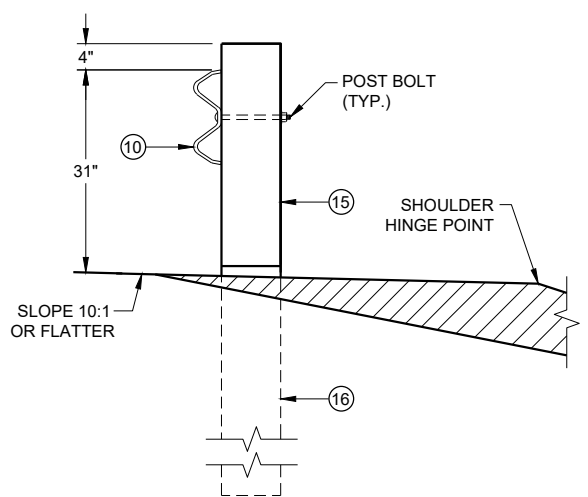
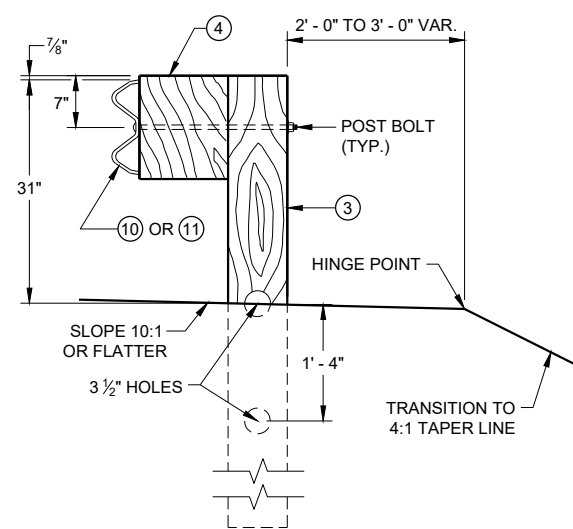
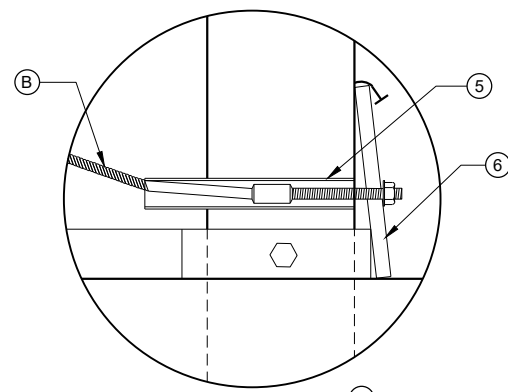
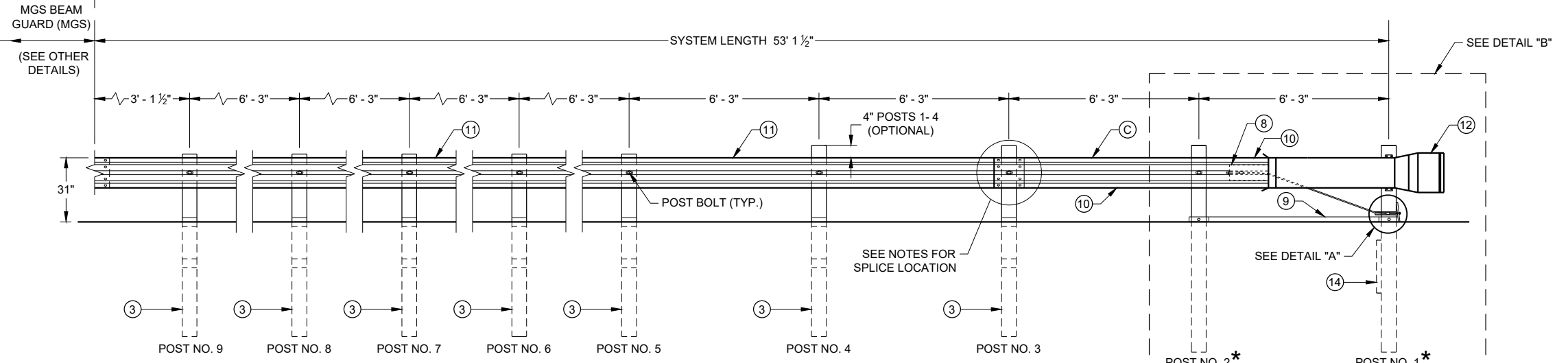
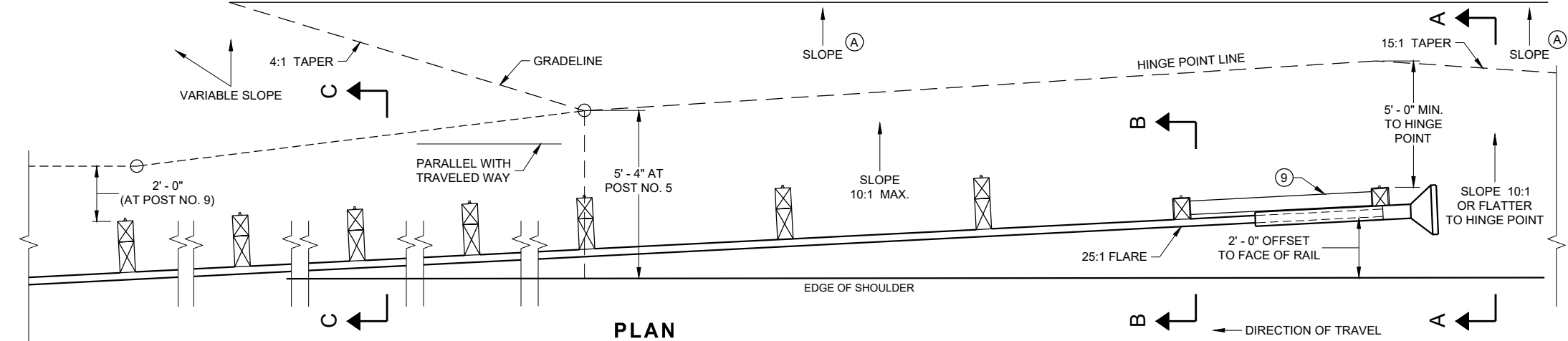

**MIDWEST GUARDRAIL SYSTEM
ENERGY ABSORBING TERMINAL
(MGS)**

STATE OF WISCONSIN
DEPARTMENT OF TRANSPORTATION

6

6

SDD 14B44 - 04a

SDD 14B44 - 04a

BILL OF MATERIALS

PART NO.	DESCRIPTION MATERIALS PROVIDED BY MGS EAT MANUFACTURER. SEE MANUFACTURER'S DETAILS FOR MORE INFORMATION.
①	UPPER POST NO. 1 6" X 6" TUBE
②	LOWER POST NO. 1
③	WOOD CRT
④	WOOD BLOCKOUT
⑤	PIPE SLEEVE
⑥	BEARING PLATE
⑦	BCT CABLE ASSEMBLY
⑧	ANCHOR CABLE BOX
⑨	GROUND STRUT
⑩	PERFORATED W-BEAM RAIL END PANEL, 12'-6" LONG.
⑪	STANDARD W-BEAM RAIL. MULTIPLE SECTIONS REQUIRED. SECTIONS VARY IN LENGTH.
⑫	IMPACT HEAD
⑬	EAT MARKER POST - YELLOW (SEE APPROVED PRODUCTS LIST)
⑭	SOIL PLATE
⑮	UPPER POST NO. 2
⑯	LOWER POST NO. 2

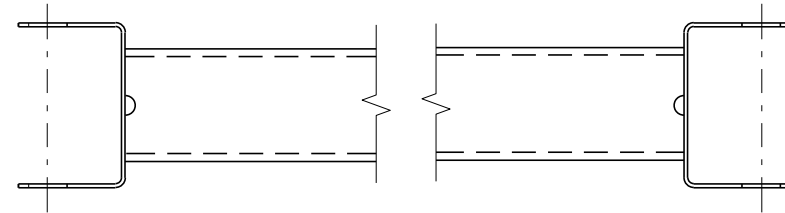

GENERIC GROUND STRUT ⑨ ⑤

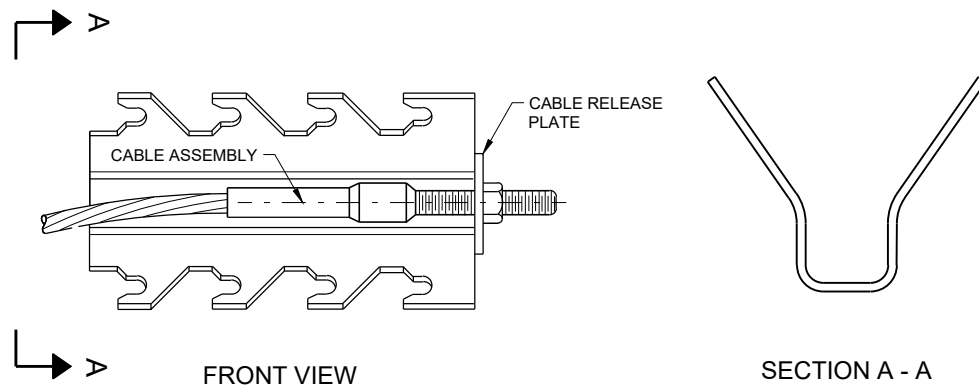

GENERIC ANCHOR CABLE BOX ⑨ ⑤

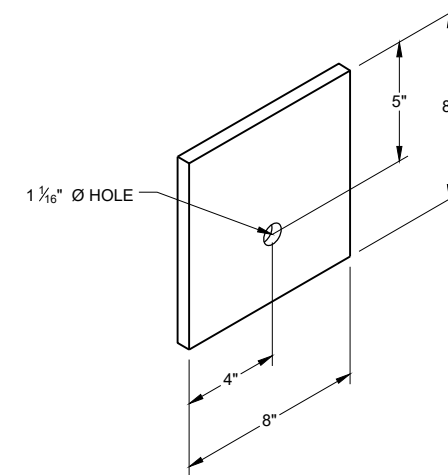

BEARING PLATE ⑥ ⑤

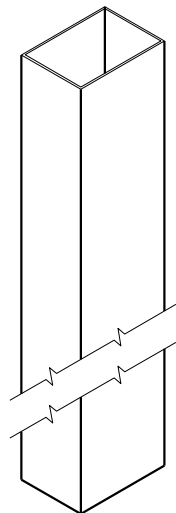

UPPER POST NO. 1 ⁽¹⁾ (E)

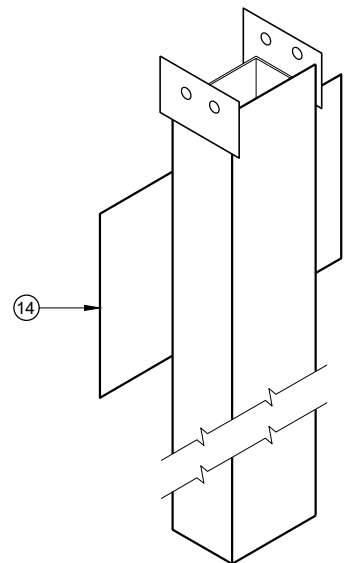

LOWER POST NO. 1 ⁽²⁾ (E)

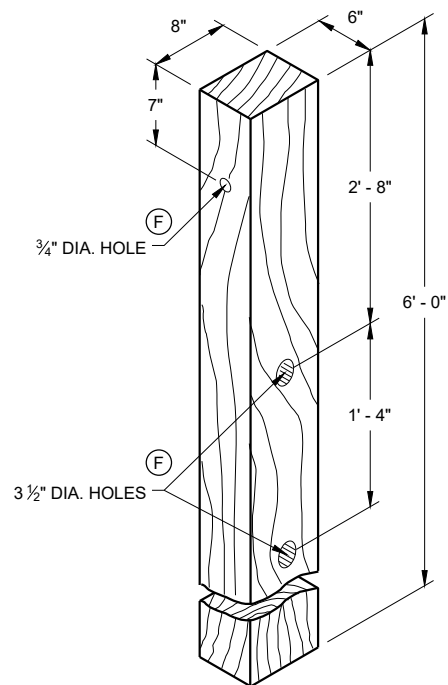

WOOD CRT POST ⁽³⁾ (E)
POSTS NUMBER 3-9

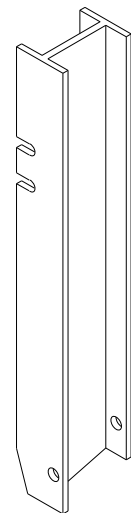

UPPER POST NO. 2 ⁽¹⁵⁾ (E)

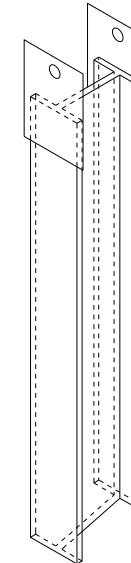

LOWER POST NO. 2 ⁽¹⁶⁾ (E)

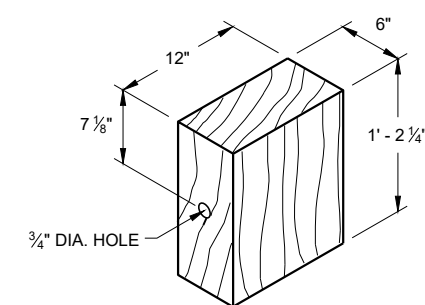

WOOD BLOCKOUT ⁽⁴⁾
REQ'D. AT ALL POSTS EXCEPT POST NO'S 1 & 2

6

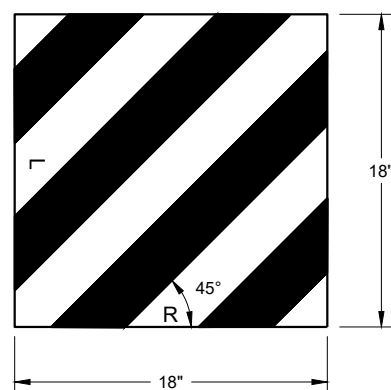

W5 - 59
REFLECTIVE SHEETING DETAIL ^(E)

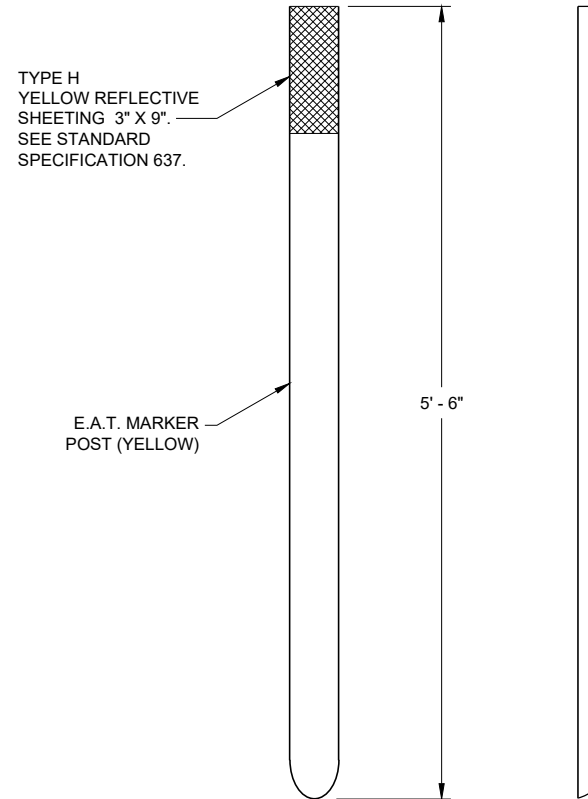

FRONT VIEW SIDE VIEW
E.A.T. MARKER POST ⁽¹³⁾

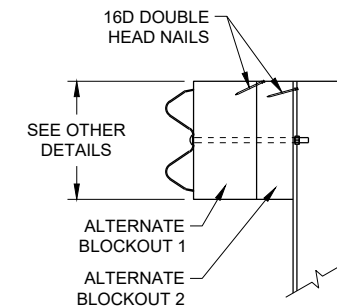

SIDE VIEW

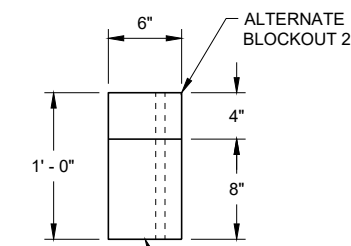

TOP VIEW

ALTERNATE WOOD BLOCKOUT DETAIL

6

SDD 14B44 - 04c

SDD 14B44 - 04c

**MIDWEST GUARDRAIL SYSTEM
ENERGY ABSORBING TERMINAL
(MGS)**

STATE OF WISCONSIN
DEPARTMENT OF TRANSPORTATION

APPROVED
7/2018 DATE /S/ Rodney Taylor
ROADWAY STANDARDS DEVELOPMENT
UNIT SUPERVISOR

FHWA

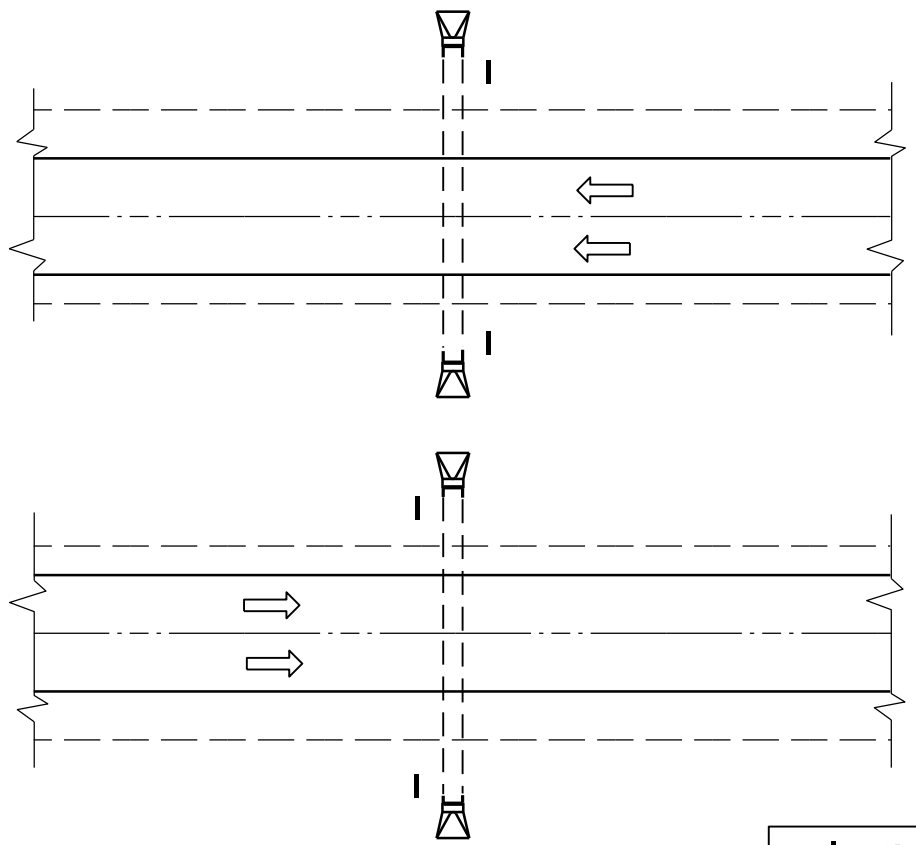

PLAN VIEW
DIVIDED HIGHWAY

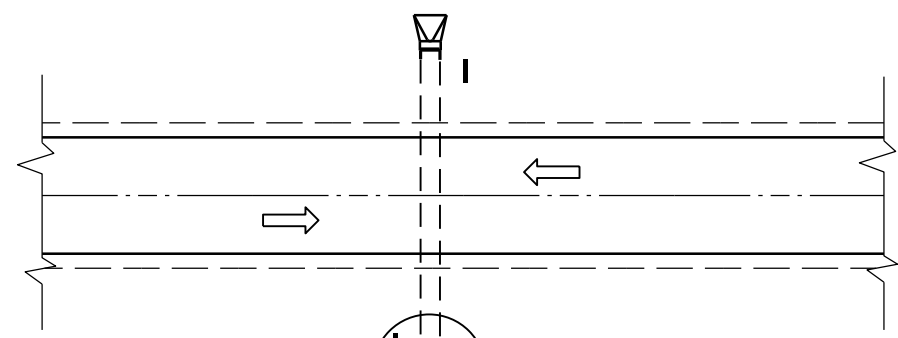

PLAN VIEW
UNDIVIDED HIGHWAY

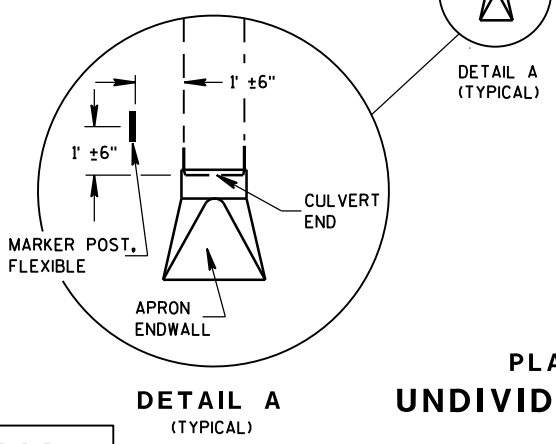

DETAIL A
(TYPICAL)

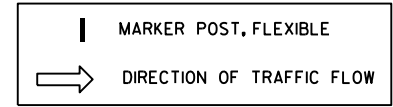

GENERAL NOTES

DETAILS OF CONSTRUCTION, MATERIALS AND WORKMANSHIP NOT SHOWN ON THIS DRAWING SHALL CONFORM TO THE PERTINENT REQUIREMENTS OF THE STANDARD SPECIFICATIONS AND THE APPLICABLE SPECIAL PROVISIONS.

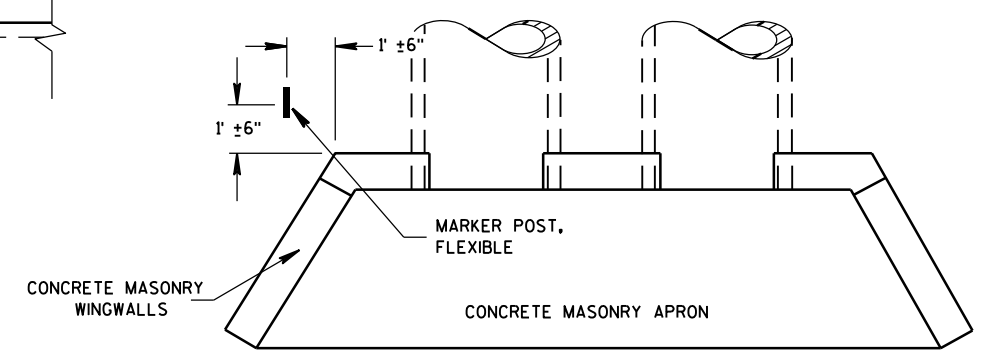

PLAN VIEW
CONCRETE MASONRY ENDWALLS FOR
CULVERT PIPE AND PIPE ARCH

FLEXIBLE MARKER POST LOCATION

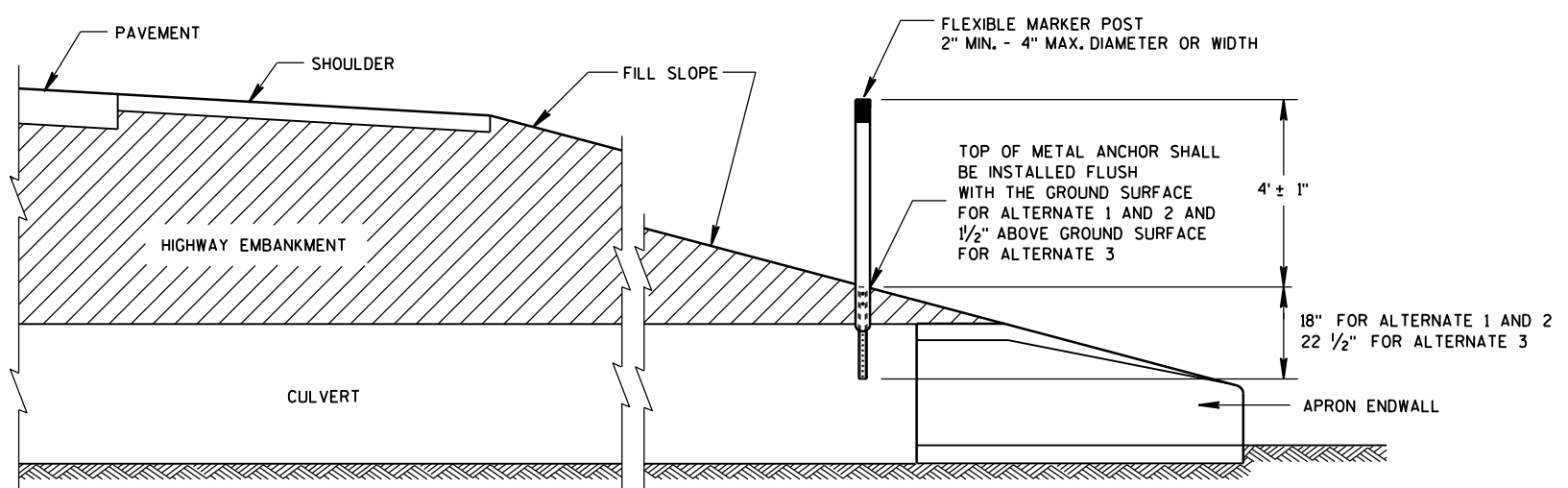

CROSS SECTION
FLEXIBLE MARKER POST

**FLEXIBLE MARKER POST
FOR CULVERT END**

STATE OF WISCONSIN
DEPARTMENT OF TRANSPORTATION

6

6

S.D.D. 15 A 3-2a

S.D.D. 15 A 3-2a

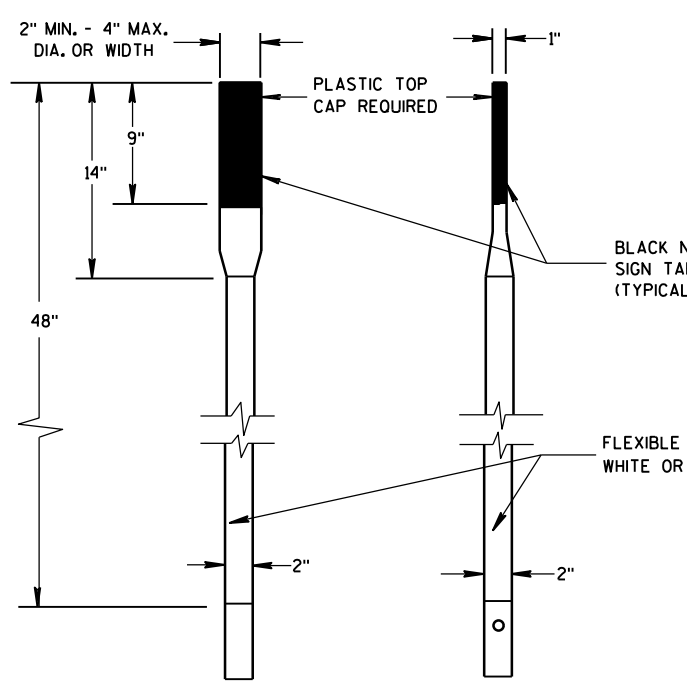

FRONT VIEW SIDE VIEW
ALTERNATE 1

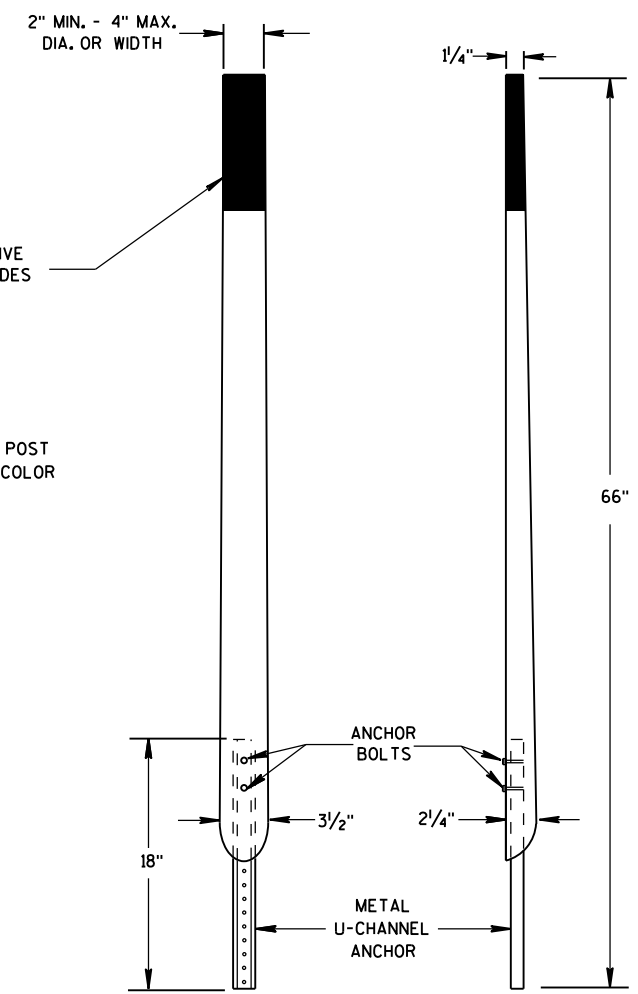

FRONT VIEW SIDE VIEW
ALTERNATE 2

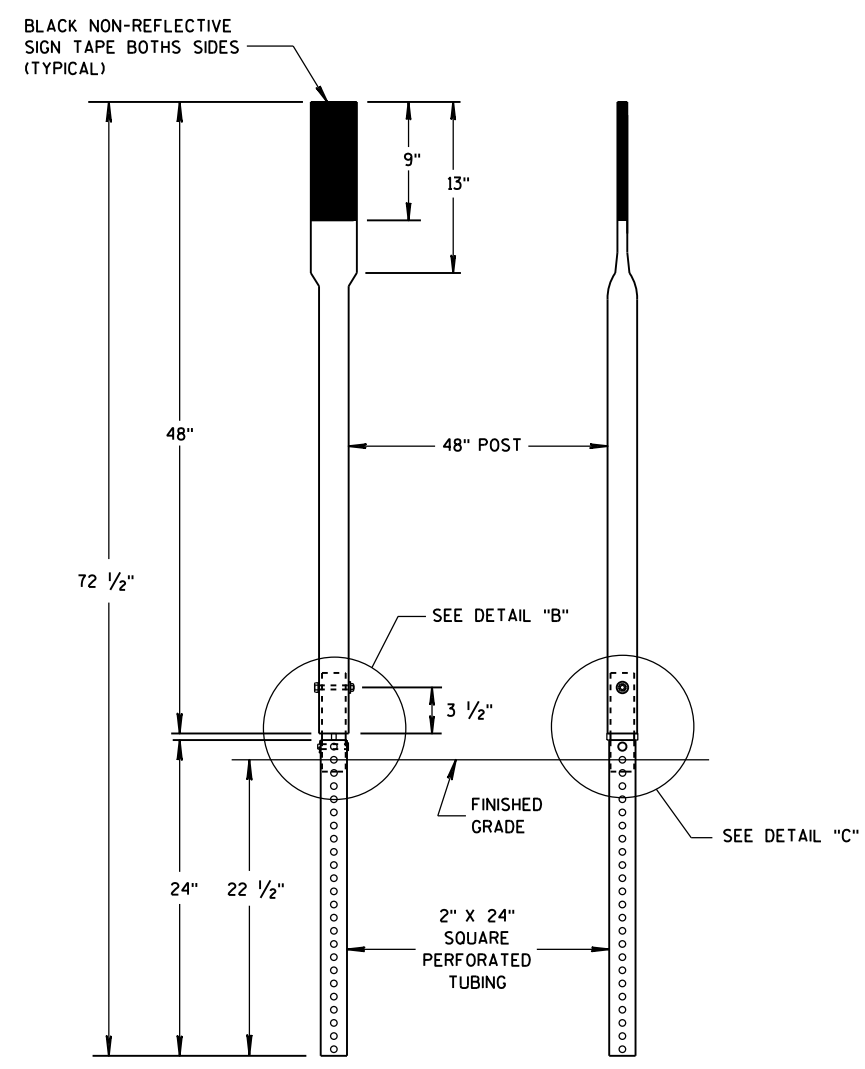

FRONT VIEW SIDE VIEW
ALTERNATE 3

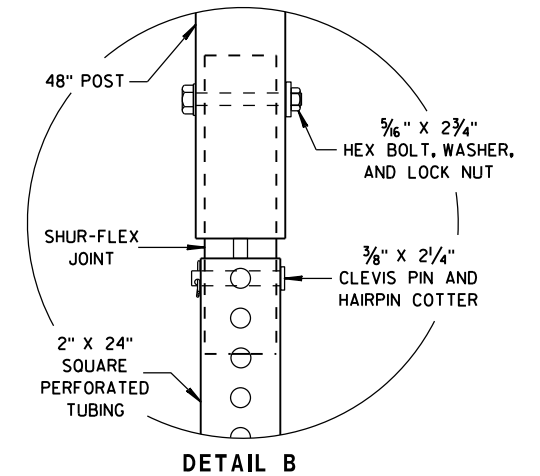

DETAIL B

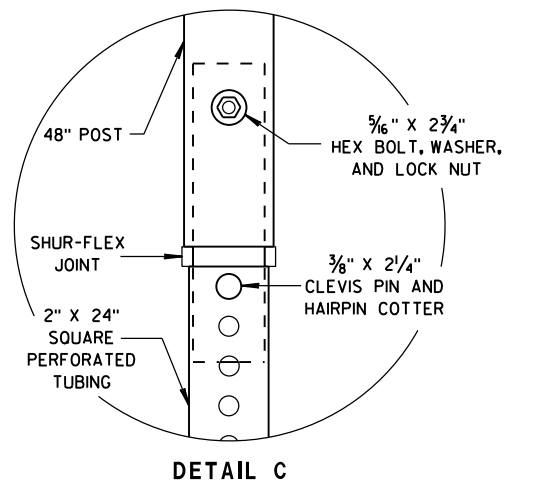

DETAIL C

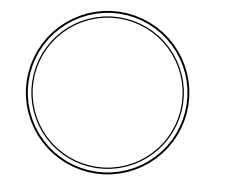

SECTION A-A

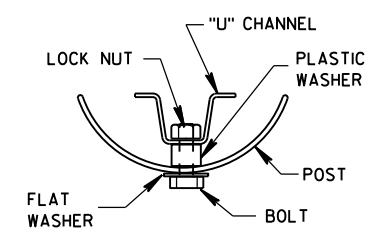

SECTION B-B

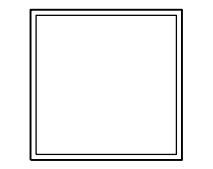

SECTION C-C

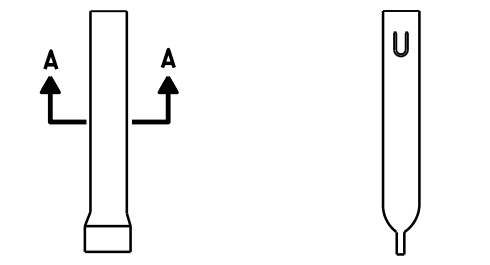

FRONT VIEW SIDE VIEW
ALTERNATE 1

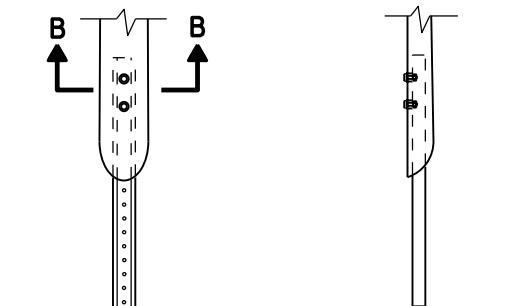

FRONT VIEW SIDE VIEW
ALTERNATE 2

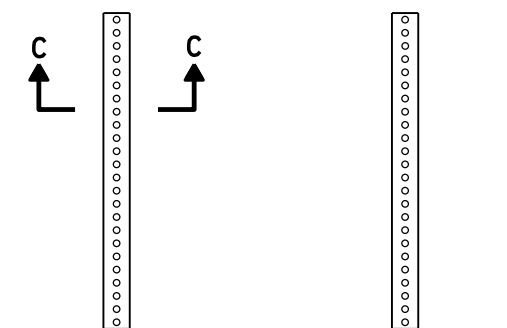

FRONT VIEW SIDE VIEW
ALTERNATE 3

FLEXIBLE MARKER POST ANCHORS

FLEXIBLE MARKER POST FOR CULVERT END

STATE OF WISCONSIN
DEPARTMENT OF TRANSPORTATION

APPROVED
10/1/2012 DATE /S/ Travis Feltes
STATE TRAFFIC ENGINEER OF DESIGN
FHWA

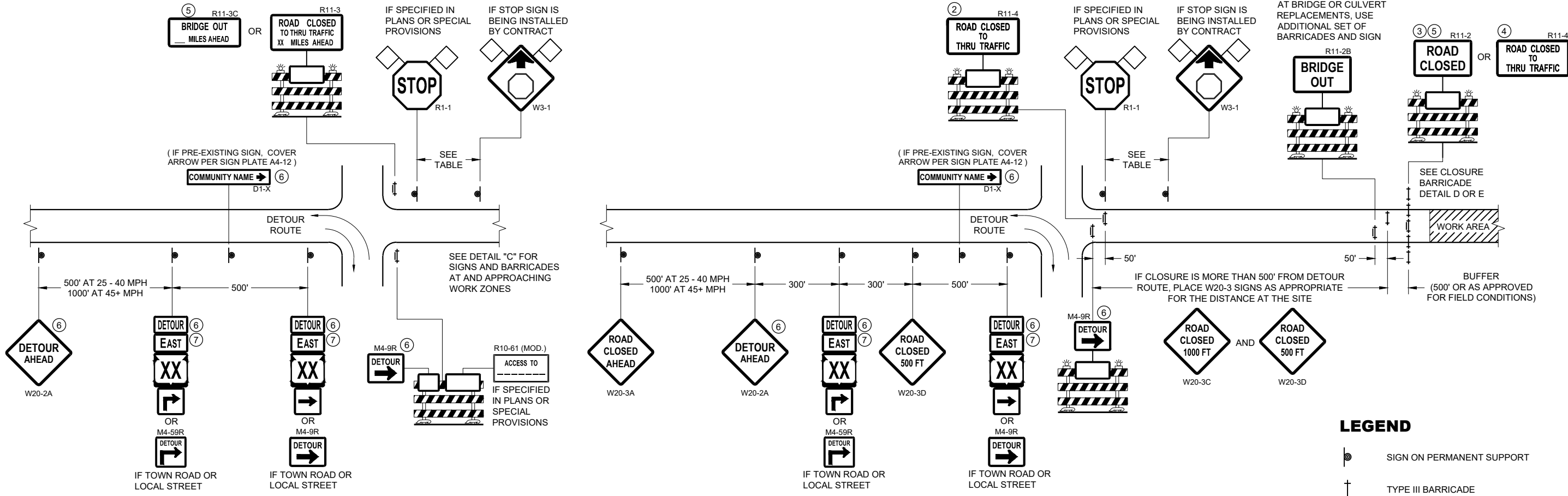

**DETAIL A
MAINLINE CLOSURE WITH POSTED DETOUR**

WORK ZONE GREATER THAN OR EQUAL TO 1/2 MILE FROM
DETOUR ROUTE (1000 FEET IF URBAN)

**DETAIL B
MAINLINE CLOSURE WITH POSTED DETOUR**

WORK ZONE LESS THAN 1/2 MILE FROM
DETOUR ROUTE (1000 FEET IF URBAN)

- LEGEND**
- SIGN ON PERMANENT SUPPORT
 - TYPE III BARRICADE
 - TYPE III BARRICADE WITH ATTACHED SIGN
 - TYPE "A" WARNING LIGHT (FLASHING)
 - WORK AREA
 - FLAGS, 16" X 16" MIN. (ORANGE)

SPEED LIMIT (MPH)	"STOP AHEAD" ADVANCE WARNING DISTANCE (FT)
25	200
30	200
35	350
40	350
45	500
50	550
55	750

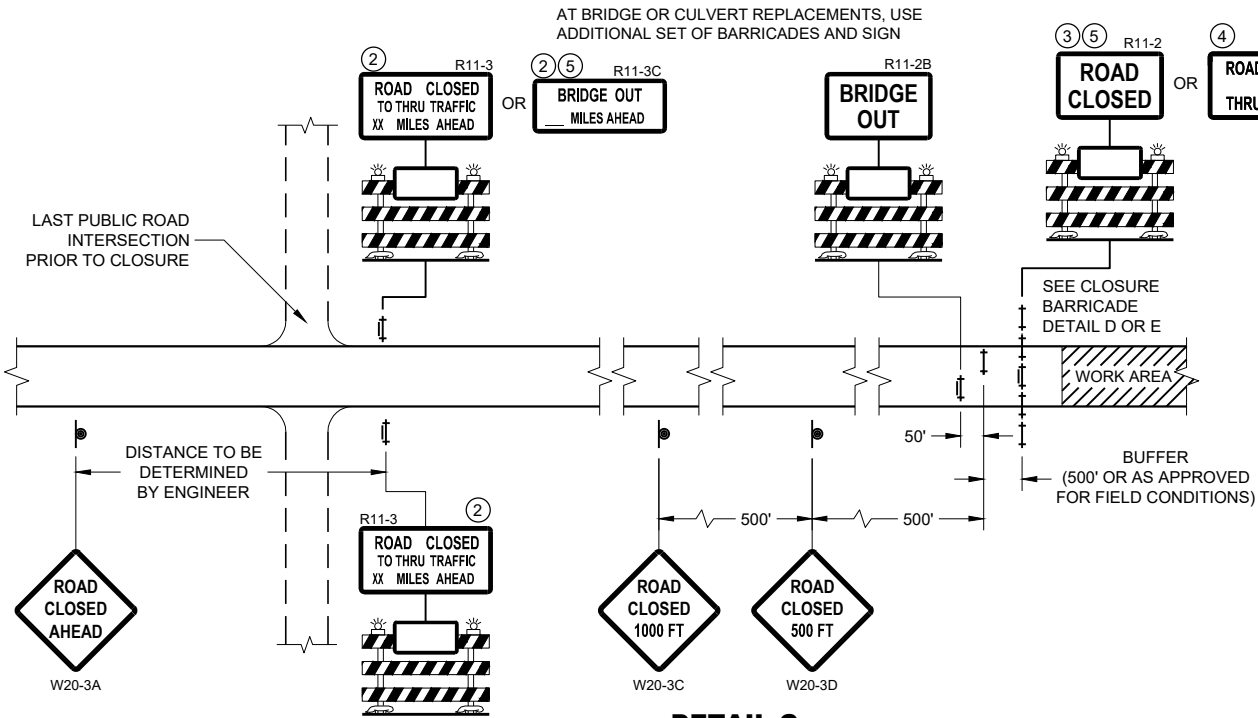

**DETAIL C
MAINLINE CLOSURE, NO POSTED DETOUR**

SEE SDD 15C2-SHEET "b"
FOR GENERAL NOTES
AND FOOTNOTES ① THROUGH ⑦

**BARRICADES AND SIGNS
FOR MAINLINE CLOSURES**

STATE OF WISCONSIN
DEPARTMENT OF TRANSPORTATION

APPROVED
May 2023 /S/ Andrew Heidtke
DATE DATE WORK ZONE ENGINEER

FHWA

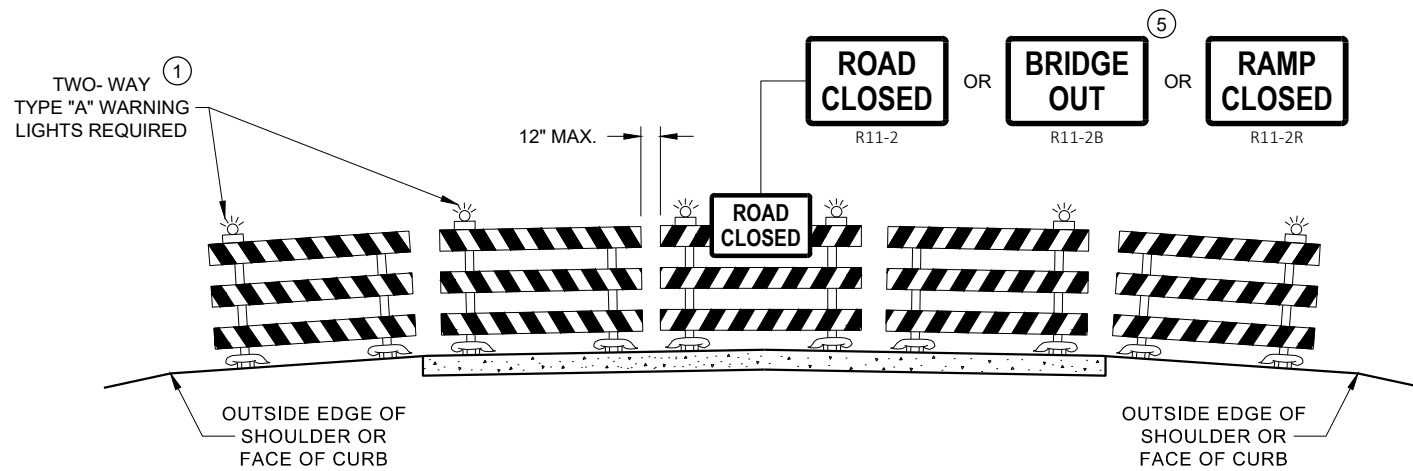

**DETAIL D
ROAD CLOSURE BARRICADE DETAIL
APPROACH VIEW**

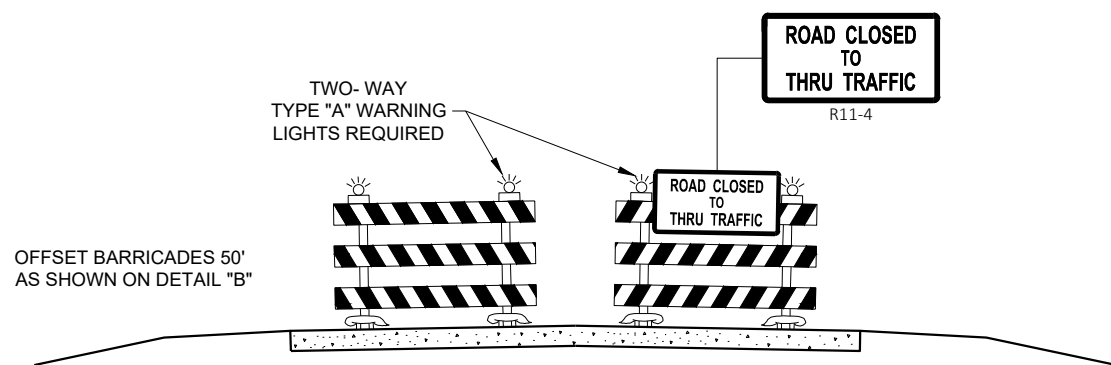

**DETAIL E
LANE CLOSURE BARRICADE DETAIL
APPROACH VIEW**

SEE SDD 15C2 - SHEET "a" FOR LEGEND

GENERAL NOTES

THE EXACT NUMBER, LOCATION, AND SPACING OF ALL SIGNS AND BARRICADES SHALL BE ADJUSTED TO FIT FIELD CONDITIONS AS APPROVED BY THE ENGINEER.

ANY SIGNS TEMPORARY OR EXISTING, WHICH CONFLICT WITH TRAFFIC CONTROL "IN USE", SHALL BE REMOVED OR COVERED AS NEEDED AND AS APPROVED BY THE ENGINEER.

THE SPACING BETWEEN TRAFFIC CONTROL SIGNS SHOULD BE ADJUSTED TO NOT CONFLICT WITH AND SHOULD PROVIDE A DESIRABLE MINIMUM OF 200 FEET CLEARANCE TO EXISTING SIGNS THAT WILL REMAIN IN PLACE.

BARRICADES THAT MUST BE MOVED FOR A WORK OPERATION SHALL BE IMMEDIATELY RE-ESTABLISHED UPON COMPLETION OF THE OPERATION, OR FOR CONTINUING OPERATIONS, AT THE END OF EACH WORKING DAY.

SIGNS THAT WILL BE IN PLACE LESS THAN 7 CONTINUOUS DAYS AND NIGHTS MAY BE MOUNTED ON PORTABLE SUPPORTS.

ALL TYPE III BARRICADES SHALL HAVE RAILS REFLECTORIZED ON BOTH FACES. STRIPES SHALL BE PROPERLY SLOPED DOWN TOWARD THE TRAFFIC SIDE OR AS SHOWN IN THE ROAD CLOSURE BARRICADE DETAIL "D" FOR FULL ROAD CLOSURES.

TYPE "A" LOW - INTENSITY FLASHING WARNING LIGHTS SHALL BE VISIBLE ON BOTH SIDES OF THE BARRICADE.

THE R11 - 2, R11 - 3, M4 - 9, R11 - 4, AND R10 - 61 SIGNS PLACED ON THE BARRICADES SHALL COVER NO MORE THAN THE TOP RAIL. THE SIGNS SHALL NOT COVER ANY PORTION OF THE MIDDLE RAIL OR BOTTOM RAILS.

"WO" AND "MO" SIGNS ARE THE SAME AS "W" AND "M" SIGNS EXCEPT THE BACKGROUND IS ORANGE.

ALL SIGNS SHALL BE 48" X 48" UNLESS OTHERWISE NOTED BELOW:

- R11 - 2 SHALL BE 48" X 30"
- R11 - 3 SHALL, R11 - 4 AND R10 - 61 SHALL BE 60" X 30"
- M4 - 9 SHALL BE 30" X 24"
- M3 - X SHALL BE 24" X 12" (36" X 18" IF NEEDED TO MATCH EXISTING SIGNS)
- M4 - 8 SHALL BE 24" X 12" (36" X 18" IF NEEDED TO MATCH EXISTING SIGNS)
- M1 - 4, M1 - 5A AND M1 - 6 SHALL BE 24" X 24" (36" X 36" IF NEEDED TO MATCH EXISTING SIGNS)
- MO5 - 1 AND MO6 - 1 SHALL BE 21" X 21" (30" X 30" IF NEEDED TO MATCH EXISTING SIGNS)
- D1 - X SHALL BE AS SHOWN ON SPECIFIC PROJECT SIGNING DETAIL SHEETS.
- R1 - 1 SHALL BE 36" X 36"

- ① TWO WARNING LIGHTS SHALL BE PROVIDED ON THE CENTER BARRICADE AND A MINIMUM OF ONE WARNING LIGHT SHALL BE PROVIDED ON EACH OF THE OTHER BARRICADES WITHIN THE ROADWAY LIMITS. SPACING OF THE WARNING LIGHTS SHALL BE UNIFORM TO THE EDGE OF ROADWAY AS SHOWN (APPROX. 8 FOOT LIGHT SPACING).
- ② THESE SIGNS AND BARRICADES ARE NOT REQUIRED IF ROAD CLOSURE BEGINS AT AN INTERSECTION.
- ③ FOR ROAD CLOSURE WITHOUT LOCAL ACCESS TO PROJECT, SEE ROAD CLOSURE BARRICADE DETAIL "D".
- ④ FOR ROAD CLOSURE WITH LOCAL ACCESS TO PROJECT, SEE ROAD CLOSURE BARRICADE DETAIL "E".
- ⑤ FOR BRIDGE OR CULVERT REPLACEMENTS, SUBSTITUTE "BRIDGE OUT" INSTEAD OF "ROAD CLOSED" ON R11 - 2 AND R11 - 3 SIGNS.
- ⑥ INSTALL DETOUR AND COMMUNITY GUIDE SIGNS AND ARROWS ONLY IF SPECIFIED IN THE CONTRACT. IF THERE ARE EXISTING ROUTE MARKER ASSEMBLIES THAT WILL REMAIN IN PLACE, ADJUST THE LOCATION OF THE DETOUR ROUTE SIGNS TO CORRESPOND WITH THE EXISTING ASSEMBLIES. MODIFY EXISTING SIGNS WHERE POSSIBLE. SEE SPECIFIC PROJECT DETOUR SIGNING DETAIL SHEETS. IF DETOUR SIGNS ARE BEING INSTALLED BY OTHERS, PLACE THE CONTRACTED TRAFFIC CONTROL SIGNS TO ALLOW FOR PLACEMENT OF ALL WARNING, DETOUR AND GUIDE SIGNS AS SHOWN.
- ⑦ "EAST" CARDINAL DIRECTION MARKERS AND RIGHT TURN ARROWS ARE SHOWN. USE OTHER CARDINAL DIRECTIONS AND ARROWS AS APPROPRIATE.

**BARRICADES AND SIGNS
FOR
VARIOUS CLOSURES**

STATE OF WISCONSIN
DEPARTMENT OF TRANSPORTATION

APPROVED
May 2023 /S/ Andrew Heidtke
DATE WORK ZONE ENGINEER



FHWA

GENERAL NOTES

DETAILS OF CONSTRUCTION NOT SHOWN ON THIS DRAWING SHALL CONFORM TO STANDARD SPECIFICATIONS AND SPECIAL PROVISIONS.

- ① LOCATE THE NO PASSING ZONE W14-3 SIGN WITHIN 50 FEET OF THE "T" MARKING
- ② MEASURE FROM EDGE OF MARKING TO JOINT LINE. THIS DOES NOT INCLUDE SPACE NEEDED FOR GROOVING OPERATIONS.

LEGEND

-  "T" MARKING
-  SIGN ON PERMANENT SUPPORT
-  DIRECTION OF TRAFFIC

* CONFIRM MARKING LINE WIDTH WITH THE MISCELLANEOUS QUANTITIES

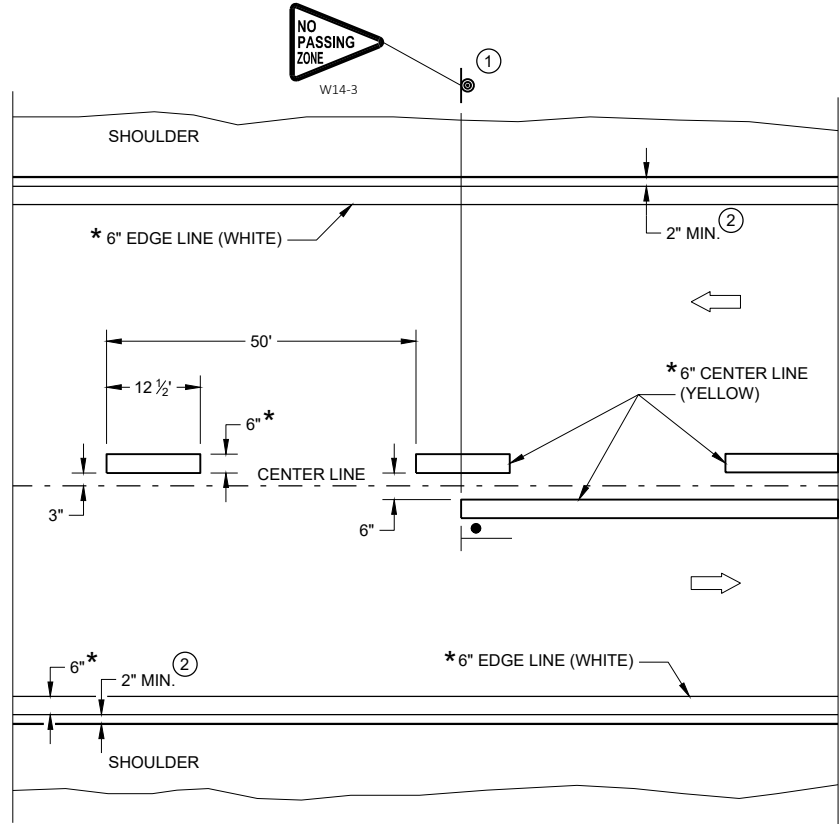

TWO WAY TRAFFIC

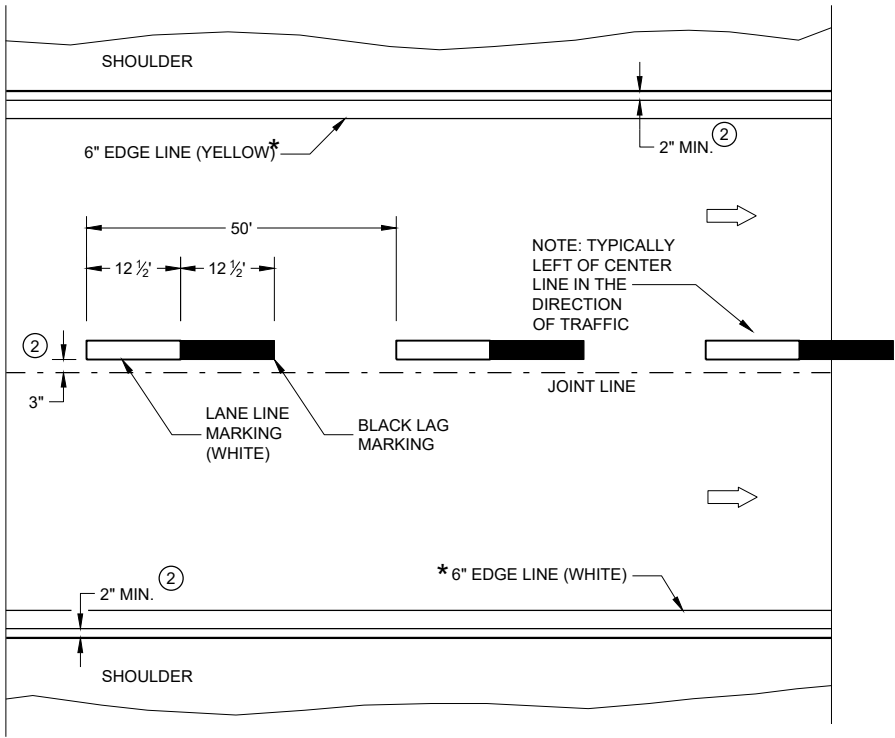

ONE WAY TRAFFIC

PERMANENT PAVEMENT MARKING

6

6

SDD 15C08-23a

SDD 15C08-23a

PERMANENT LONGITUDINAL PAVEMENT MARKINGS

STATE OF WISCONSIN
DEPARTMENT OF TRANSPORTATION

APPROVED
May 2023 /S/ Jeannie Silver
DATE STATEWIDE SIGNING AND MARKING ENGINEER

FHWA

URBAN AREA

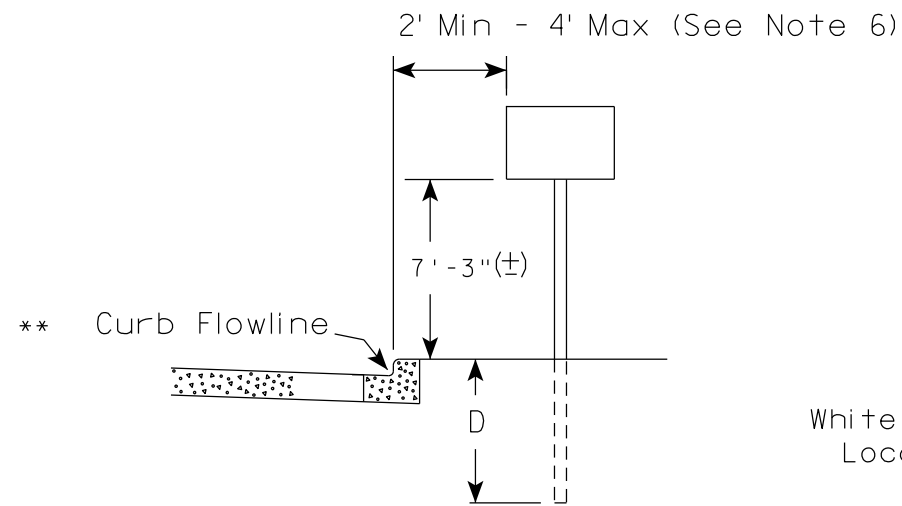

RURAL AREA (See Note 2)

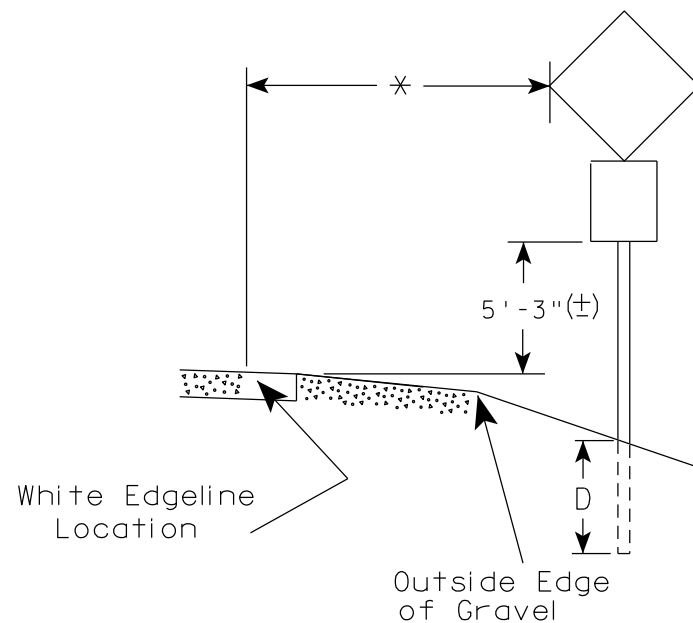
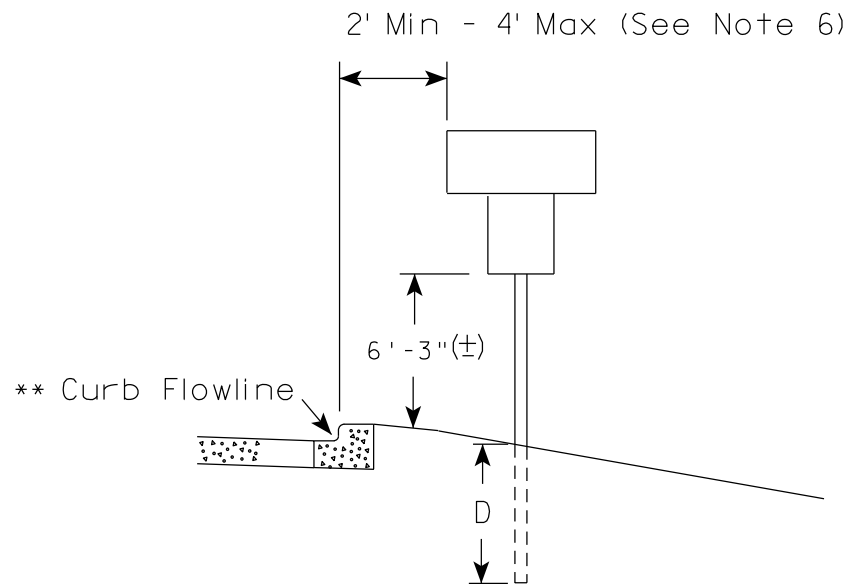
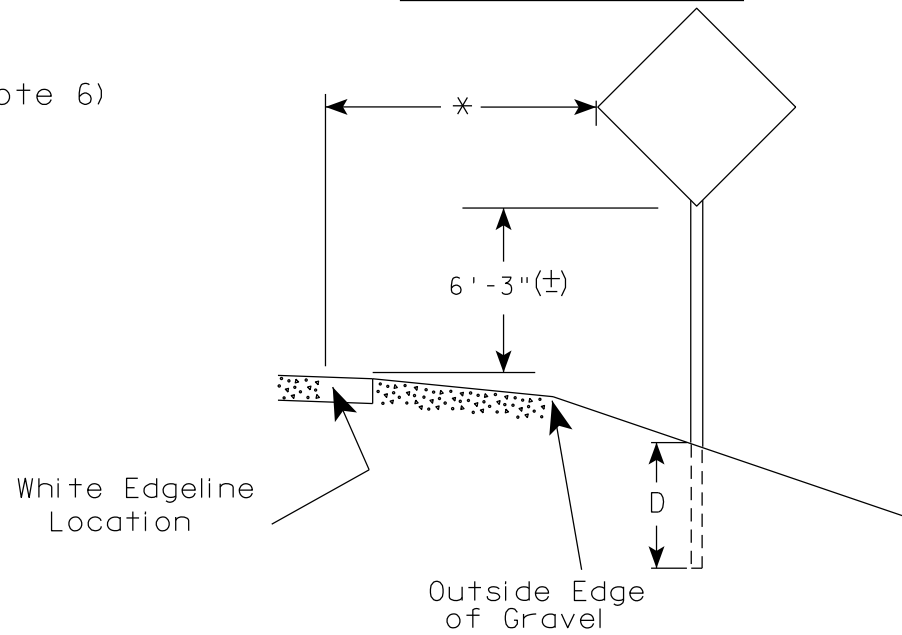

GENERAL NOTES

1. Signs wider than 4 feet or 20 sq.ft or larger, shall be mounted on multiple posts. Refer to plate A4-4.
2. If signs are mounted on or behind barrier wall, see A4-10 sign plate.
The Double Arrow sign (W12-1D) shall be mounted at a height of 2'-3" (±). The Chevron sign (W1-8), Roundabout Chevron panel (R6-4B), Enhanced Reference Markers, Clearance Markers (W5-52), Mile Markers (D10 series), In Road Object Markers (W5-54) & End of Road Markers (W5-56) shall be mounted at a height of 4'-3" (±).
3. For expressways and freeways, mounting height is 7'- 3" (±) or 6'-3" (±) depending upon existence of a sub-sign.
4. Minimum mounting height for signs mounted on traffic signal poles is 5'- 3" (±).
5. Offset distance shall be consistent with existing signs or consistent throughout length of project.
6. The (±) tolerance for mounting height is 3 inches.
7. Folding signs shall be mounted at a height of 5'-3" (±) or as directed by the Engineer.

POST EMBEDMENT DEPTH

Area of Sign Installation (Sq. Ft.)	D (Min)
20 or Less	4'
Greater than 20	5'

* * The existence of curb and gutter does not in itself mandate the vertical clearance illustrated. That height is typically measured where there is sidewalk adjacent to the roadway or parking is permitted. In the absence of sidewalk vertical clearance is measured from the top of the curb. Offset of signs is measured from the flow line.

* 6 feet from edge of a paved shoulder or 12 feet from the edge of pavement (edge line location) or 2 feet from outside edge of gravel, whichever is greater unless directed by project engineer.

TYPICAL INSTALLATION OF PERMANENT TYPE II SIGNS ON SINGLE POSTS

WISCONSIN DEPT OF TRANSPORTATION

APPROVED *Matthew R. Rauch*
for State Traffic Engineer

DATE 5/13/2020 PLATE NO. A4-3.22



ELEVATION VIEW

DETAIL OF WOOD 4 X 6 SIGN POST IN BOX-OUT

- NOTES:**
1. ALL MATERIAL TO BE APPROVED BY ENGINEER PRIOR TO INSTALLATION
 2. SEE SIGN PLATE A4-8 FOR SIGN HARDWARE REQUIREMENTS
 3. 18 INCH X 18 INCH SQUARE BOX-OUTS MAY BE USED FOR INSTALLATIONS IN EXISTING CONCRETE OR ASPHALT LOCATIONS.



ELEVATION VIEW

DETAIL OF STEEL 2 X 2 SIGN POST IN BOX-OUT



PLAN VIEW

FOR NEW CONCRETE/ ASPHALT INSTALLATIONS

SIGN POST BOX-OUTS A4-3B	
<small>WISCONSIN DEPT OF TRANSPORTATION</small>	
APPROVED <i>Matthew R. Rauch</i> <small>for State Traffic Engineer</small>	
<small>DATE 1/27/14</small>	<small>PLATE NO. A4-3B.1</small>

GENERAL NOTES

1. For 3 or 4 post installations, individual post spacing shall be greater than 3'-6".
2. See tables below for required number of posts.
3. For expressways and freeways, mounting height is 7'-3" (±) or 6'-3" (±) depending upon existence of sub-sign.
4. The (±) tolerance for mounting height is 3 inches.
5. J-Assemblies are considered to be one sign for mounting height.
6. Offset distance shall be consistent with existing signs or consistent throughout length of project.
7. Folding signs shall be mounted at a height of 5'-3" (±) or as directed by the engineer.
8. The Double Arrow sign (W12-1) shall be mounted at a height of 2'-3" (±). The Chevron sign (W1-8), Roundabout Chevron panel (R6-4B), Clearance Markers (W5-52), Mile Markers (D10 series), In Road Object Markers (W5-54) & End of Road Markers (W5-56) shall be mounted at a height of 4'-3" (±).

URBAN AREA

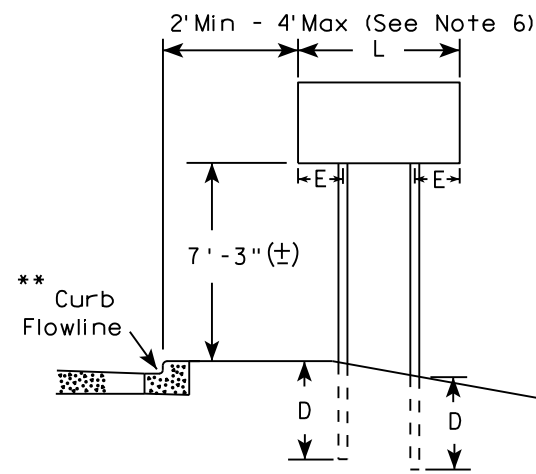

RURAL AREA (See Note 3)

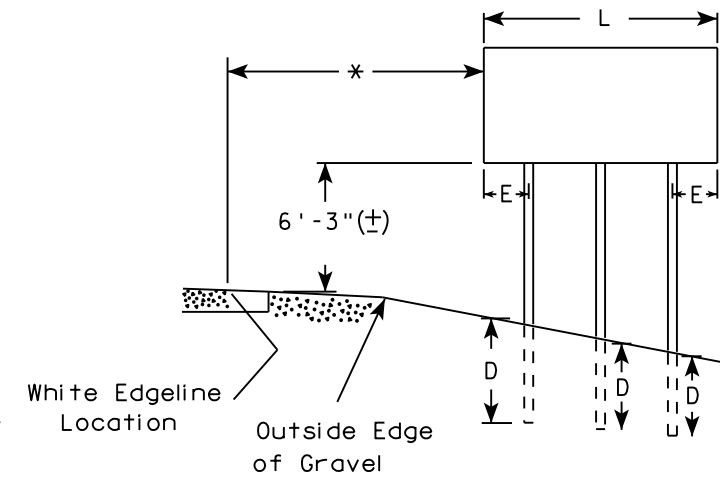
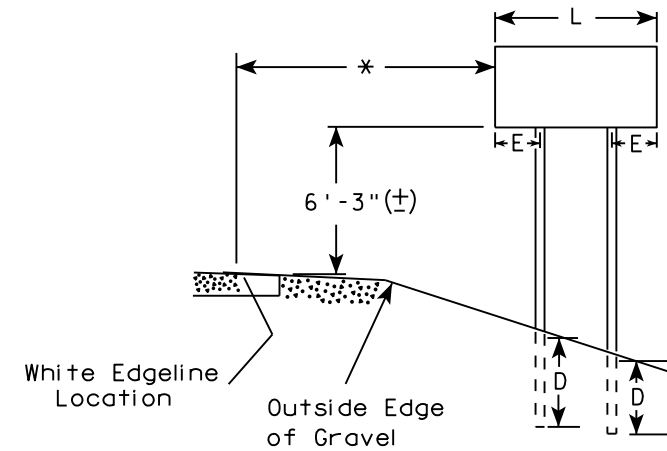

2' Min - 4' Max (See Note 6)

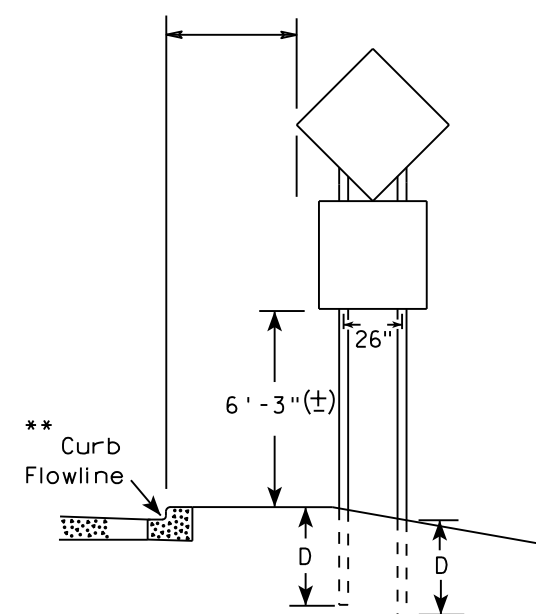

48" DIAMOND WARNING SIGN

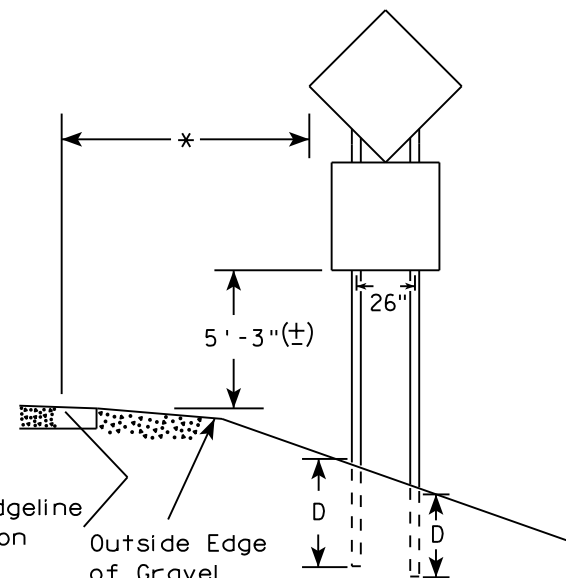

48" DIAMOND WARNING SIGN

* 6 feet from edge of a paved shoulder or 12 feet from the edge of pavement (edge line location) or 2 feet from outside edge of gravel, whichever is greater unless directed by project engineer.

** The existence of curb and gutter does not in itself mandate the vertical clearance illustrated. That height is typically measured where there is sidewalk adjacent to the roadway or parking is permitted. In the absence of sidewalk vertical clearance is measured from the top of the curb. Offset of signs is measured from the flow line.

*** See A4-3 sign plate for signs 4' or less in width and less than 20 S.F. in area.

SIGN SHAPE OTHER THAN DIAMOND (TWO POSTS REQUIRED)	
L	E
Greater than 48" Less than 60"	12"
60" to 108"	L/5

SIGN SHAPE OTHER THAN DIAMOND (THREE POSTS REQUIRED)	
L	E
Greater than 108" to 144"	12"

POST EMBEDMENT DEPTH

Area of Sign Installation (Sq. Ft.)	D (Min)
20 or Less	4'
Greater than 20	5'

TYPICAL INSTALLATION OF TYPE II SIGNS ON MULTIPLE POSTS

WISCONSIN DEPT OF TRANSPORTATION
 APPROVED *Matthew R. Rauch*
 For State Traffic Engineer
 DATE 8/21/17 PLATE NO. A4-4.15

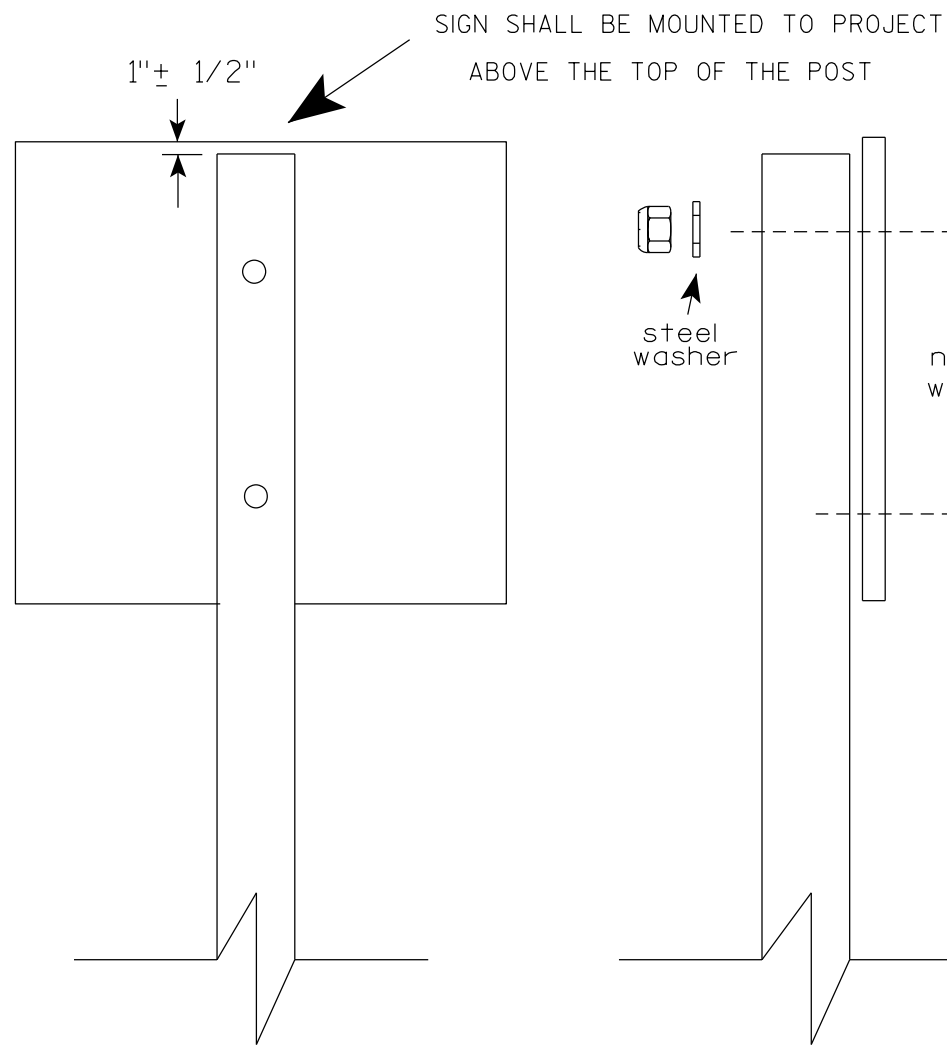

Nuts, bolts and lags used for mounting signs shall have hexagonal heads and shall be either :

- a. Hot dip galvanized in accordance with ASTM Designation: A 153, Class D, or SC 3
- b. Electro-galvanized in accordance with ASTM Designation : B 633, TYPE III, SC 3.

Threads on bolts and nuts shall be manufactured with sufficient allowance for the cadmium plate or galvanized coating to permit the nuts to run freely on the bolts.

STRINGER BOLTING TO ALUMINUM SIGNS (SEE SIGN PLATE A4-18)

MACHINE BOLTS - 5/16" X 1-3/4" Length w/ lock nuts

WOOD POSTS (4" x 6")

LAG SCREWS - 3/8" X 3" (NO STRINGERS ON BACK OF SIGN)
3/8" X 4" (STRINGERS ON BACK OF SIGN)

SQUARE STEEL POSTS (2" x 2")

MACHINE BOLTS - 3/8" X 3-1/4" Length w/ nuts (NO STRINGER ON BACK OF SIGN)
3/8" X 5" Length w/ nuts (STRINGERS ON BACK OF SIGN)

RIVETS - 9/32" (6605-9-6) BULB-TITE, TRI-FOLD, ALUMINUM BODY/MANDREL
O.D. FLANGE .720-.765 INCH, GRIP RANGE .042-.375 INCH

WASHERS (ALL POSTS) -

1-1/4" O.D. X 3/8" I.D. X 1/16" STEEL

1-1/4" O.D. X 3/8" I.D. X .080 NYLON

* Two different fastening systems are shown for illustration purposes. On any individual sign, either one or the other system shall be used. Actual number of fasteners per sign varies with the sign area, but normally there are two. For a single post installation, all signs greater than 9 sq. ft. require the use of 3 fasteners.

ATTACHMENT OF SIGNS
TO POSTS

WISCONSIN DEPT OF TRANSPORTATION

APPROVED *Matthew R Rauch*
For State Traffic Engineer

DATE 4/1/2020 PLATE NO. A4-8.9

**TELESCOPIC TUBING ANCHORS
TWO PIECE SYSTEM**

2 1/4" SQUARE
12 GAUGE
PERFORATED
GALVANIZED FINISH

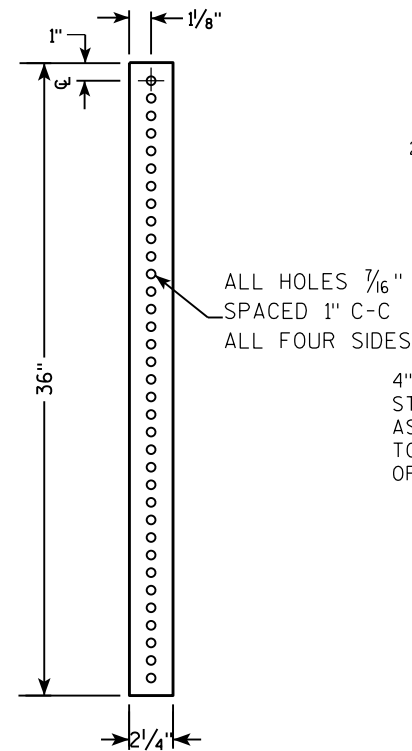

2 1/2" SQUARE
12 GAUGE
OMNI-DIRECTIONAL
PERFORATED
SOIL STABILIZING SLEEVE
GALVANIZED FINISH

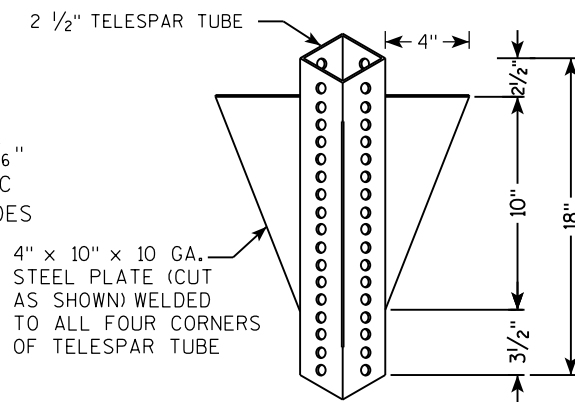

**DETAIL OF TUBULAR STEEL SIGN POST
(IN POURED CONCRETE OR ASPHALT)**

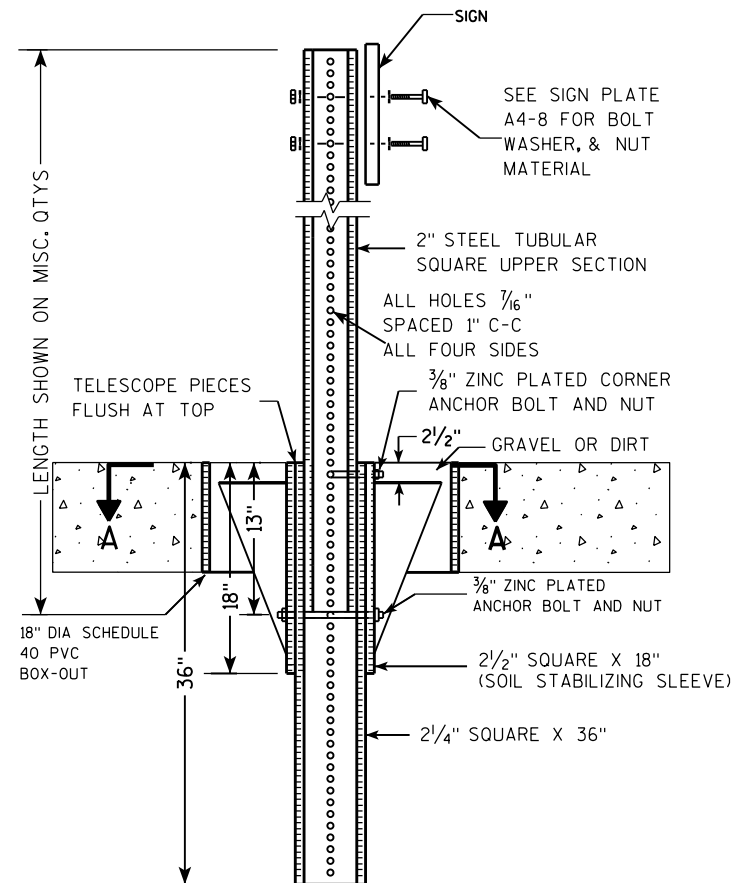

**DETAIL OF TUBULAR STEEL SIGN POST
(IN LOCATIONS OTHER THAN POURED CONCRETE OR ASPHALT)**

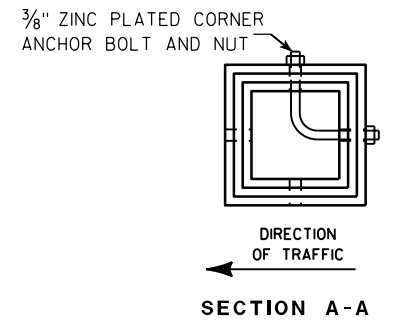
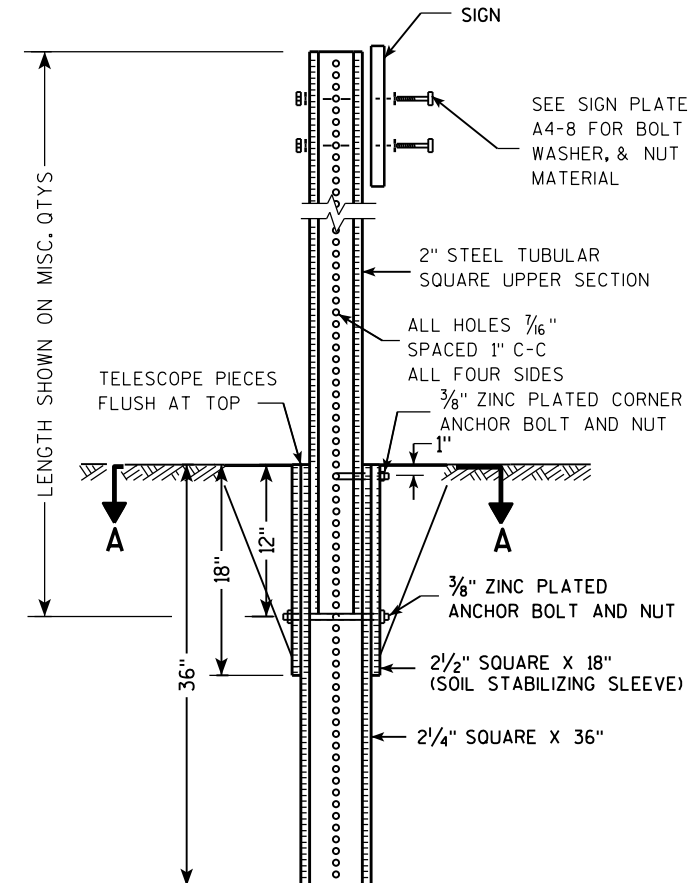

Area of Sign Installation (Sq. Ft.)	Number of Required Posts
9 or less	1
Greater than 9 less than or equal to 18	2
Greater than 18 less than or equal to 27	3

Signs wider than 3 feet or larger than 9 sq. ft shall be mounted on multiple posts (see above table).

**TUBULAR STEEL
SIGN POST
A4-9**

WISCONSIN DEPT OF TRANSPORTATION

APPROVED *Matthew R. Rauch*
for State Traffic Engineer

DATE 2/05/15 PLATE NO. A4-9.9

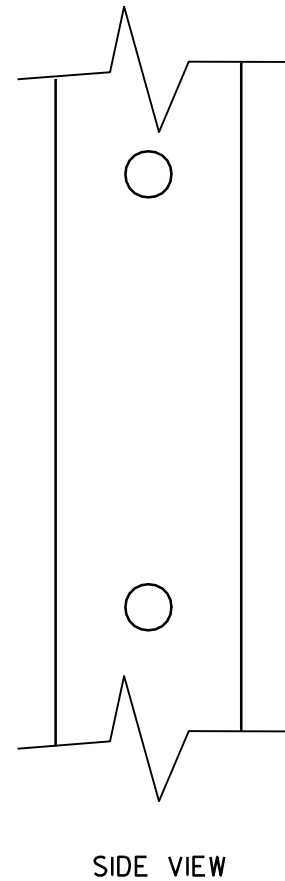
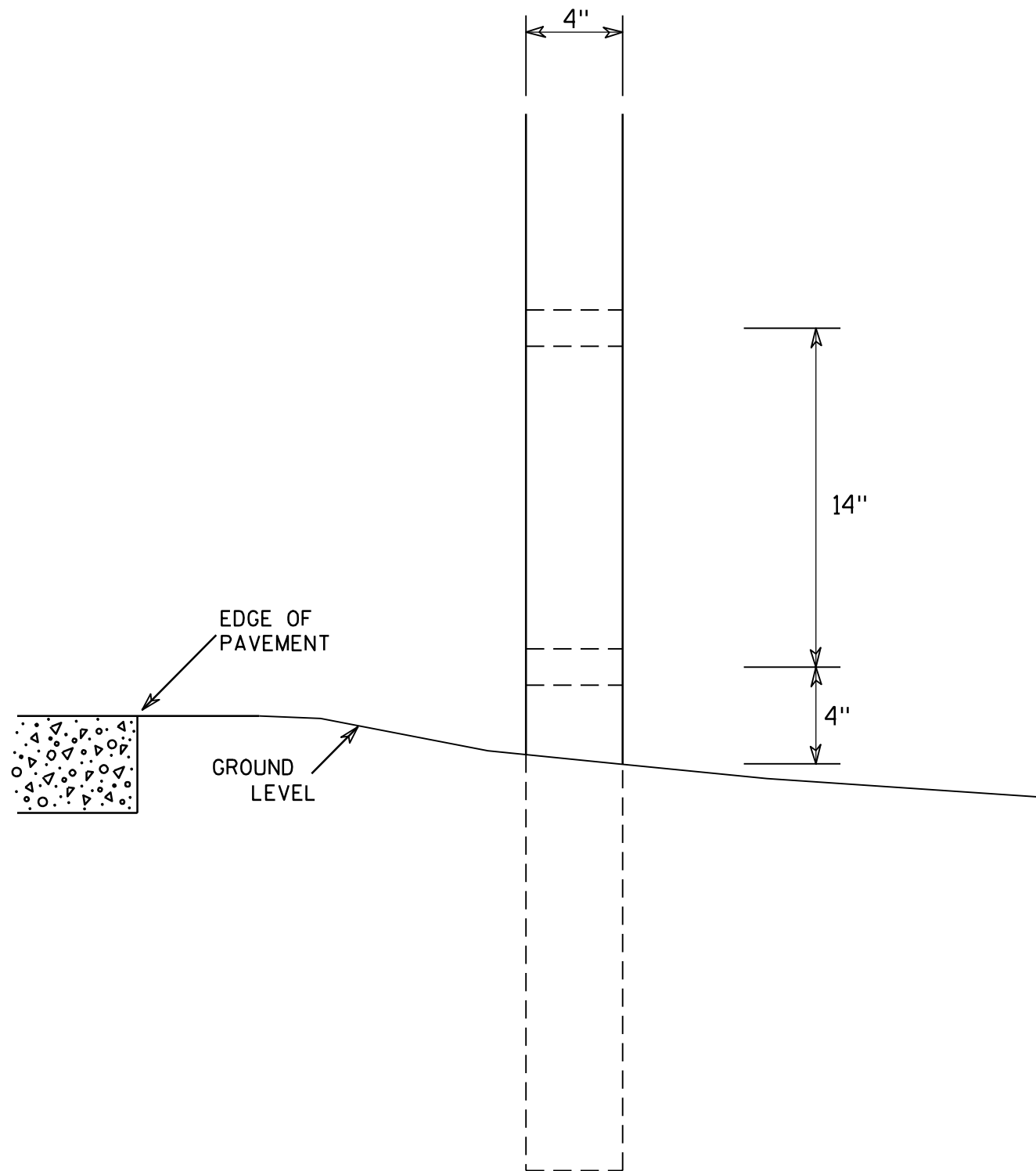

GENERAL NOTES

1. All 4 x 6 Wood Posts shall be modified by having two 1½" diameter holes drilled perpendicular to the roadway centerline.

7

7

4 X 6 WOOD POST MODIFICATIONS	
<i>WISCONSIN DEPT OF TRANSPORTATION</i>	
APPROVED	<i>Chester J Spang</i> for State Traffic Engineer
DATE <u>3/27/97</u>	PLATE NO. <u>A4-11.2</u>

BANDING

SINGLE SIGN

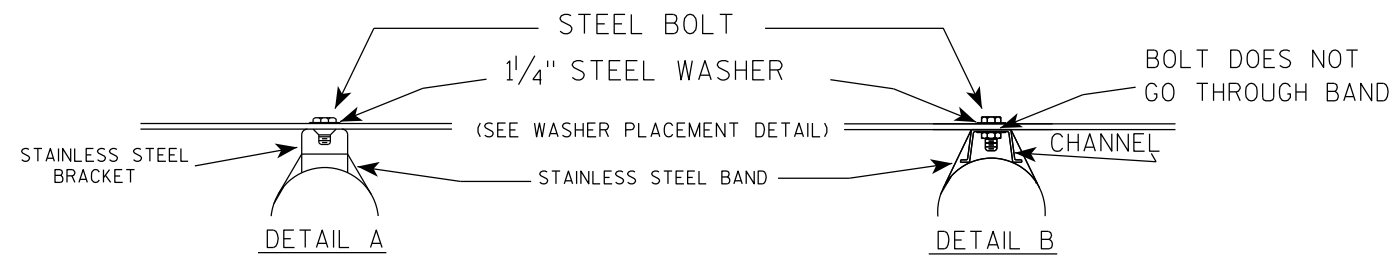
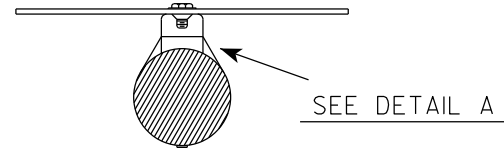
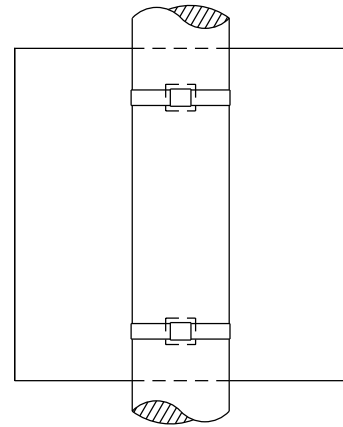

GENERAL NOTES

1. Any sign over 3 feet in width shall use the V-Block banding method. See A5-10 standard plate.
2. Signs 3 feet or greater in height shall have three bracket bands installed. Signs less than 3 feet in height shall have two bracket bands installed.
3. Banding and assembly bracket shall be stainless steel. All bands shall be 3/4" in width and 0.025" thickness.
4. ALL SIGN MOUNTING BOLTS AND WASHERS SHALL BE EITHER:
 - a. Hot dip or mechanically galvanized in accordance with ASTM Designation: A 153, Class D
 - b. Electro-galvanized in accordance with ASTM designation: B 633, Type III, SC 3

"J" ASSEMBLY

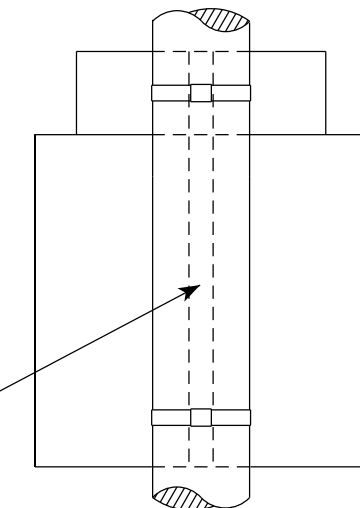

CHANNEL
SEE TYPICAL PANEL
INSTALLATION SHEET



WASHER PLACEMENT

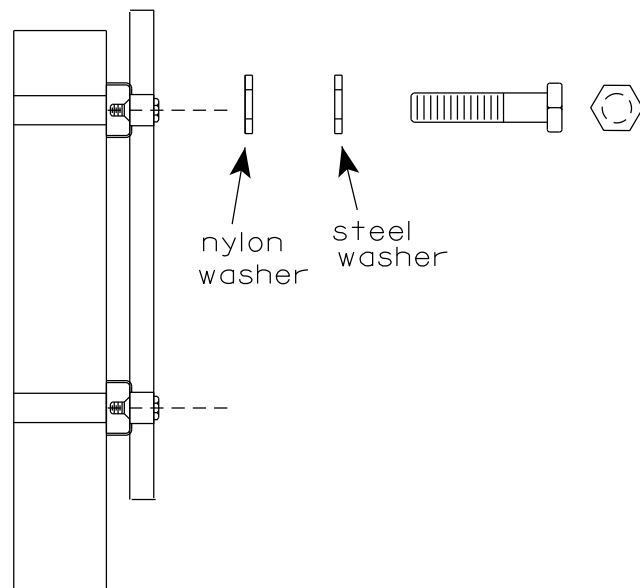

WASHERS (ALL POSTS) -
1-1/4" O.D. X 3/8" I.D. X 1/16" STEEL
1-1/4" O.D. X 3/8" I.D. X .080 NYLON
FOR ALL TYPE H SIGNS

STANDARD SIGN
SIGN BANDING DETAILS

WISCONSIN DEPT OF TRANSPORTATION

APPROVED *Matthew R. Rauch*
for State Traffic Engineer

DATE 6/10/19 PLATE NO. A5-9.4

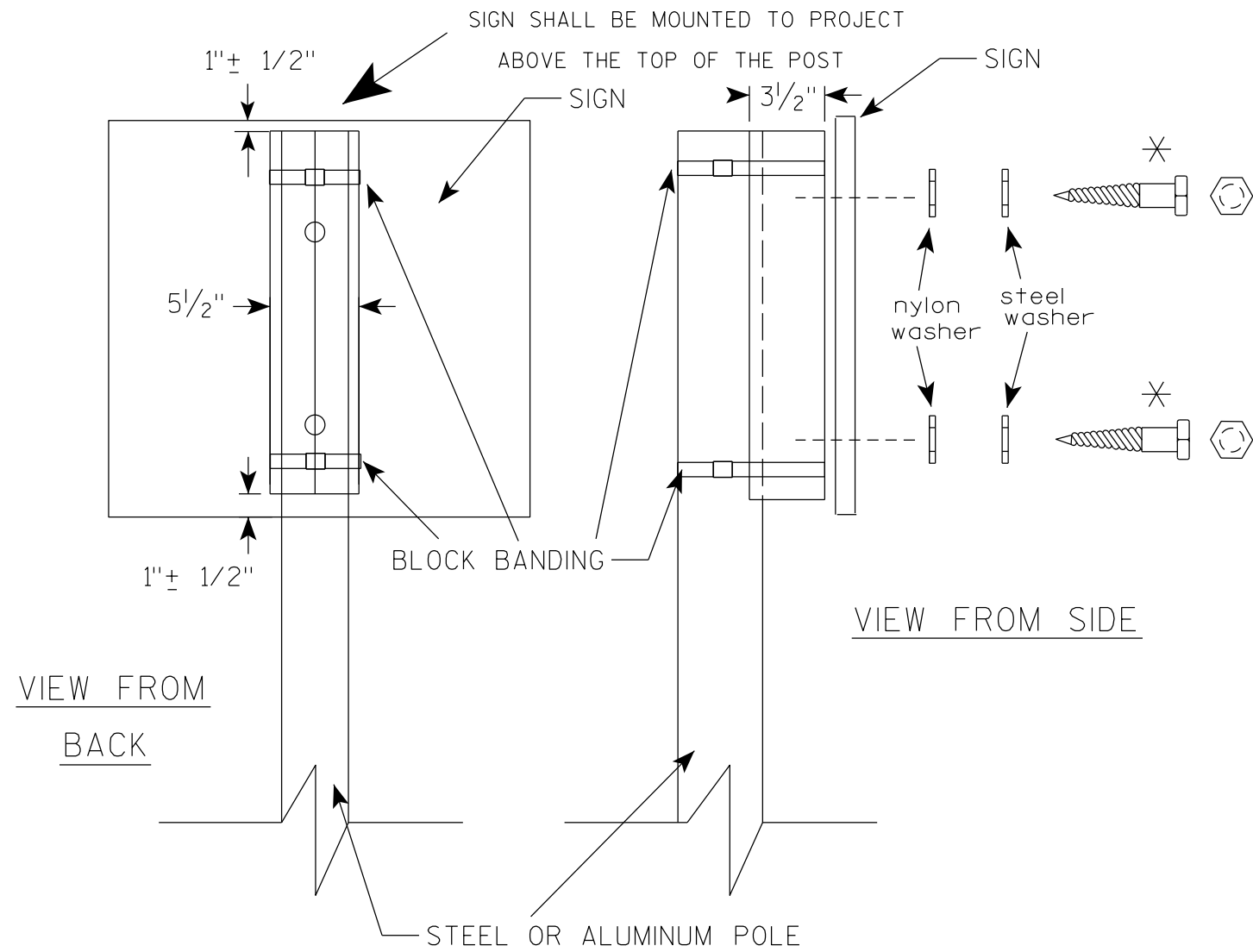

GENERAL NOTES

1. WOOD 4"X6" POST MATERIAL SHALL CONFORM TO 507.2.2 OF THE WISDOT STANDARD SPECIFICATIONS
2. BLOCK BANDING AND CLIPS SHALL BE STAINLESS STEEL, 3/4" WIDTH AND 0.025" THICKNESS
3. SIGNS 3' OR GREATER IN HEIGHT SHALL UTILIZE 3 BLOCK BANDS. SIGNS UNDER 3' IN HEIGHT SHALL UTILIZE 2 BLOCK BANDS
4. ACTUAL NUMBER OF FASTENERS PER SIGN VARIES WITH THE SIGN AREA, BUT NORMALLY THERE ARE TWO. FOR SIGNS GREATER THAN 9 S.F. 3 FASTENERS SHALL BE USED.
5. ALL SIGN MOUNTING BOLTS AND WASHERS SHALL BE EITHER:
 - a. Hot dip or mechanically galvanized in accordance with ASTM Designation: A 153, Class D
 - b. Electro-galvanized in accordance with ASTM Designation : B 633, TYPE III, SC 3
6. ALL BOLTS SHALL HAVE HEXAGONAL HEADS.
7. STEEL WASHERS SHALL BE 1/4" O.D. X 3/8" I.D. X 1/16"
8. NYLON WASHERS SHALL BE 1/4" O.D. X 3/8" I.D. X .080 FOR TYPE H OR TYPE F FACE SIGN

✱ LAG BOLTS SHALL BE 3/8" X 2 1/2"

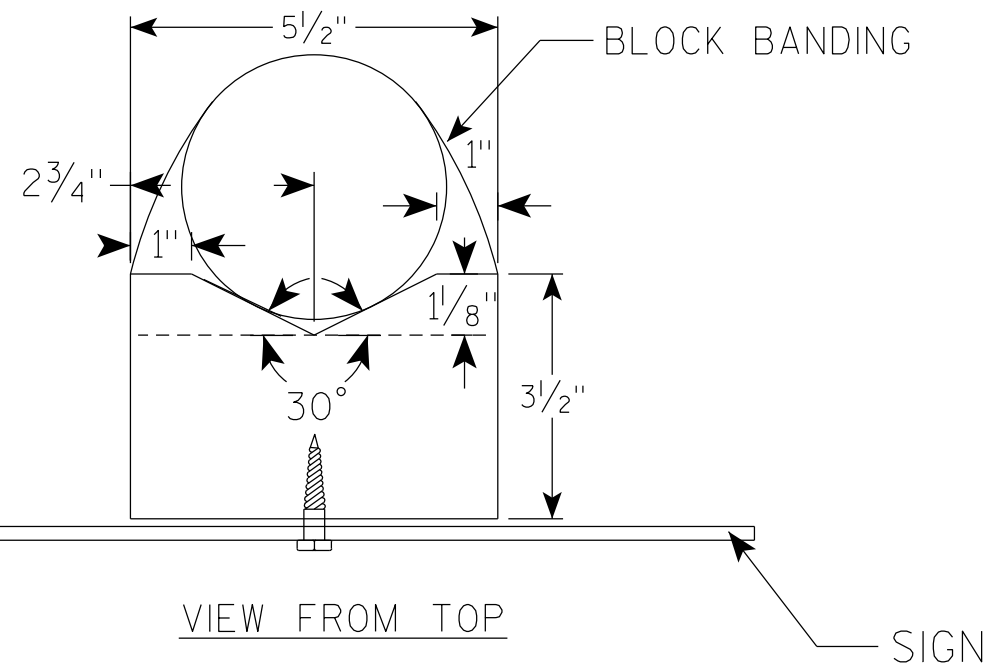

BLOCK BANDING DETAIL
(V-BLOCK OPTION)

WISCONSIN DEPT OF TRANSPORTATION

APPROVED *Matthew R. Rauch*
for State Traffic Engineer

DATE 4/19/2022 PLATE NO. A5-10.3

NOTES

1. Sign is Type II - Type F Reflective - reference WIS DOT Standard Specification for HIGHWAY and STRUCTURE CONSTRUCTION latest edition.
2. Color:
Background - Orange
Message - Black
3. Message Series - C
4. Corners may be square or rounded when base material is plywood but borders shall be rounded as shown. When base material is metal, the corners and borders shall be rounded.

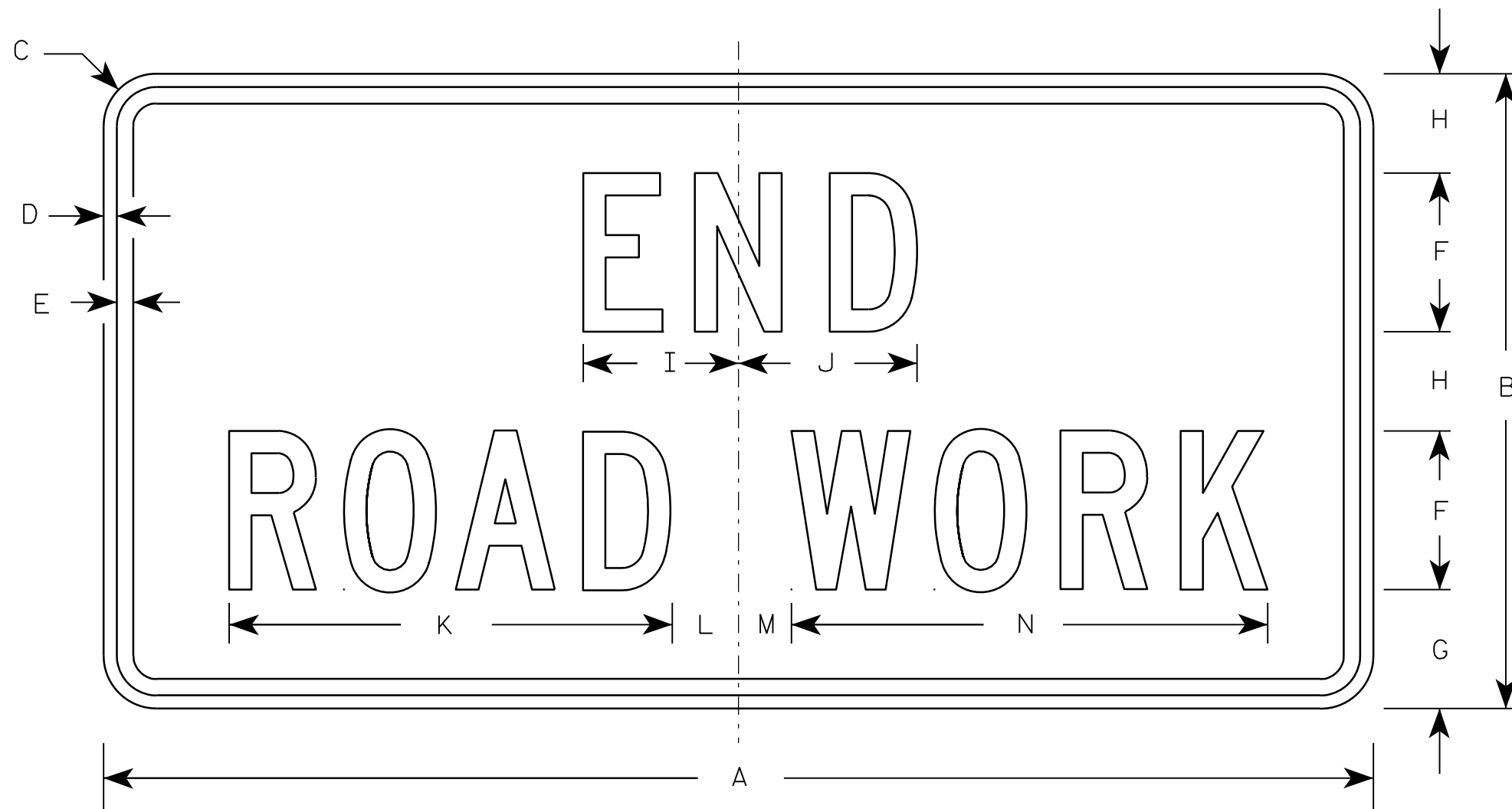

G20-2A

7

7

Metric equivalent for this sign is:

SIZE	
1	900 mm X 450 mm
2	1200 mm X 600 mm
3	1200 mm X 600 mm
4	1200 mm X 600 mm
5	1200 mm X 600 mm

SIZE	A	B	C	D	E	F	G	H	I	J	K	L	M	N	O	P	Q	R	S	T	U	V	W	X	Y	Z	Area sq. ft.	Area sq. m.
1	36	18	1 1/8	3/8	1/2	4	3 3/4	2 1/2	4 1/8	4 1/8	11 1/8	2	1	12 1/8													4.5	0.41
2	48	24	1 1/2	1/2	5/8	6	4 1/2	3 3/4	5 7/8	6 3/4	16 3/4	2 1/2	1 3/4	18 1/2													8.0	0.72
3	48	24	1 1/2	1/2	5/8	6	4 1/2	3 3/4	5 7/8	6 3/4	16 3/4	2 1/2	1 3/4	18 1/2													8.0	0.72
4	48	24	1 1/2	1/2	5/8	6	4 1/2	3 3/4	5 7/8	6 3/4	16 3/4	2 1/2	1 3/4	18 1/2													8.0	0.72
5	48	24	1 1/2	1/2	5/8	6	4 1/2	3 3/4	5 7/8	6 3/4	16 3/4	2 1/2	1 3/4	18 1/2													8.0	0.72

STANDARD SIGN G20-2A	
WISCONSIN DEPT OF TRANSPORTATION	
APPROVED	<i>Matthew R. Rauch</i> For State Traffic Engineer
DATE 9/30/09	PLATE NO. G20-2A.8

PROJECT NO:	HWY:	COUNTY:	SHEET NO:	E
-------------	------	---------	-----------	----------

NOTES

1. Sign is Type II - see Note 7 - reference WIS DOT Standard Specification for HIGHWAY and STRUCTURE CONSTRUCTION latest edition.
2. Color:
Background - White & Black - See Note 7
Message - Black
3. Message Series - see Note 5
4. Corners may be square or rounded when base material is plywood but borders shall be rounded as shown. When base material is metal, the corners and borders shall be rounded.
5. Message Series E for 1 letter.
Message Series D for 2 letters unless message is too big then Series C.
Message Series C for 3 letters unless message is too big then Series B.
6. Substitute appropriate letters & optically center to achieve proper balance.
7. Permanent Signs
Background - Type H Reflective
Detour or temporary Signs
Background - Reflective

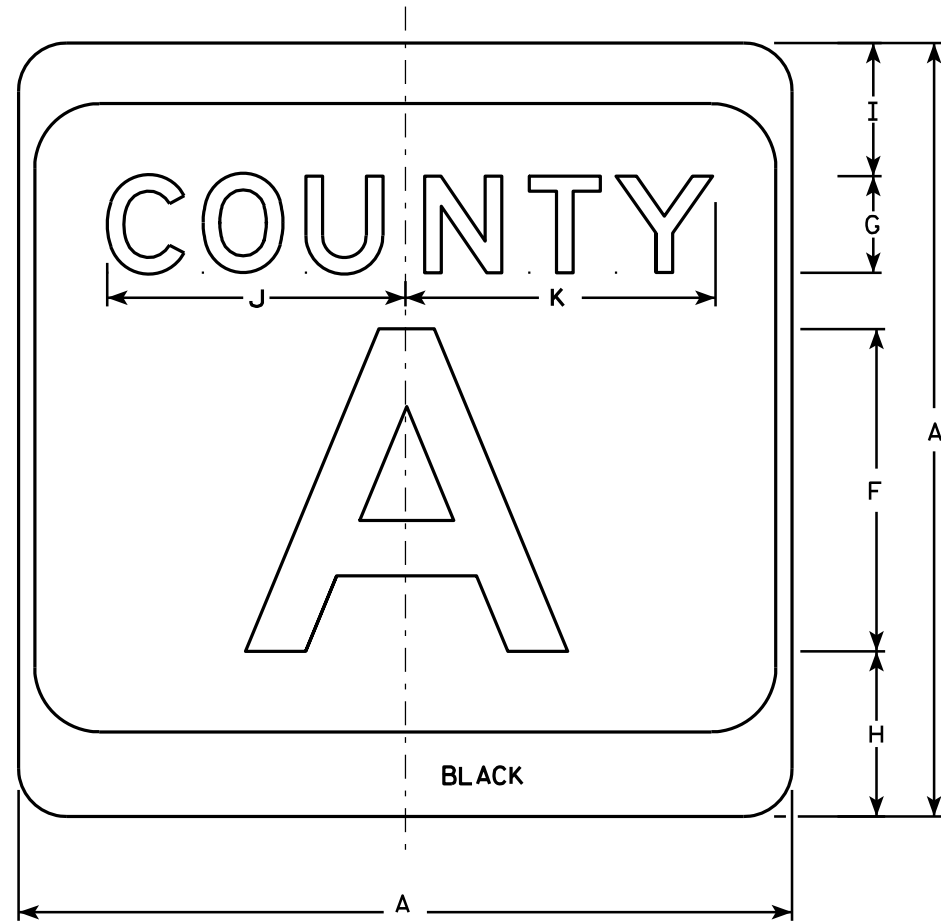

M1-5A

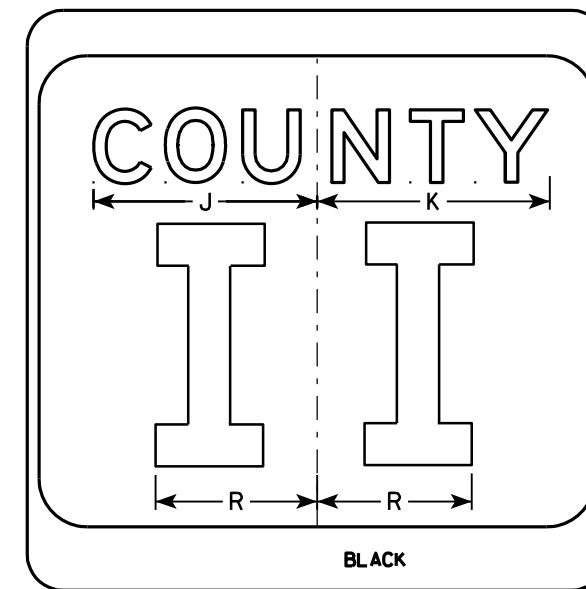
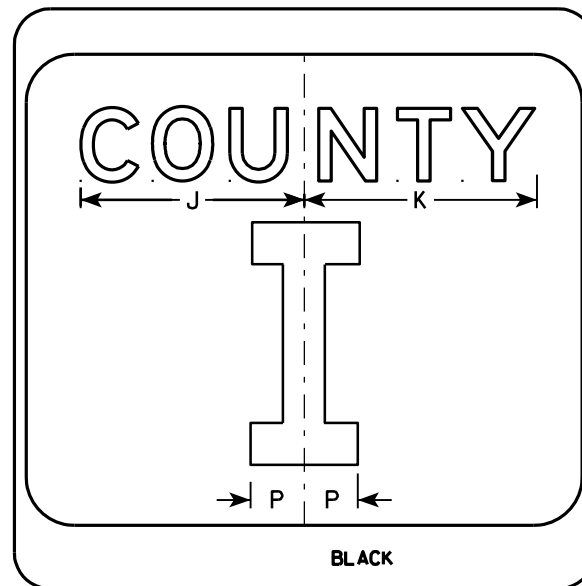
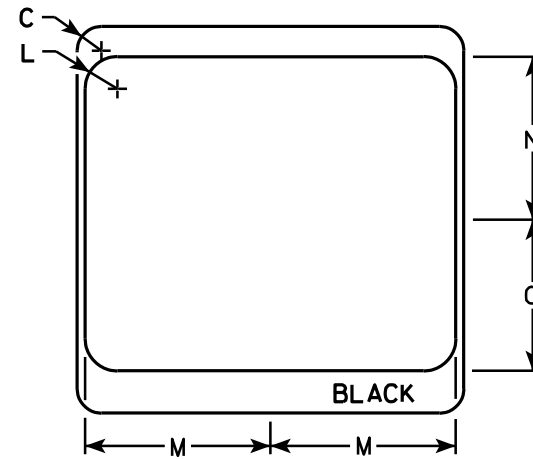

7

7

SIZE	A	B	C	D	E	F	G	H	I	J	K	L	M	N	O	P	Q	R	S	T	U	V	W	X	Y	Z	Area sq. ft.
1																											
2	24		1 1/2			10	3	5 1/8	4 1/8	9 1/4	9 5/8	2	11 1/2	10 1/8	9 3/8	2 1/4		6 5/8									4.0
3	36		2 1/4			16	4	7 5/8	5 5/8	12 1/4	12 7/8	3	17 1/8	15 1/4	14	3 3/8		10									9.0
4	36		2 1/4			16	4	7 5/8	5 5/8	12 1/4	12 7/8	3	17 1/8	15 1/4	14	3 3/8		10									9.0
5	36		2 1/4			16	4	7 5/8	5 5/8	12 1/4	12 7/8	3	17 1/8	15 1/4	14	3 3/8		10									9.0

CTH MARKER
M1-5A FOR ASSEMBLIES

WISCONSIN DEPT OF TRANSPORTATION

APPROVED *Matthew R. Raub*
For State Traffic Engineer

DATE 9/27/11 PLATE NO. MI-5A.8

PROJECT NO: _____ HWY: _____ COUNTY: _____ SHEET NO: **E**

NOTES

1. Sign is Type II - Type H Reflective
2. Color:
Background - White
Message - Black
3. Message Series - D except 3 number signs Series C
4. Corners may be square or rounded when base material is plywood but borders shall be rounded as shown. When base material is metal, the corners and borders shall be rounded.

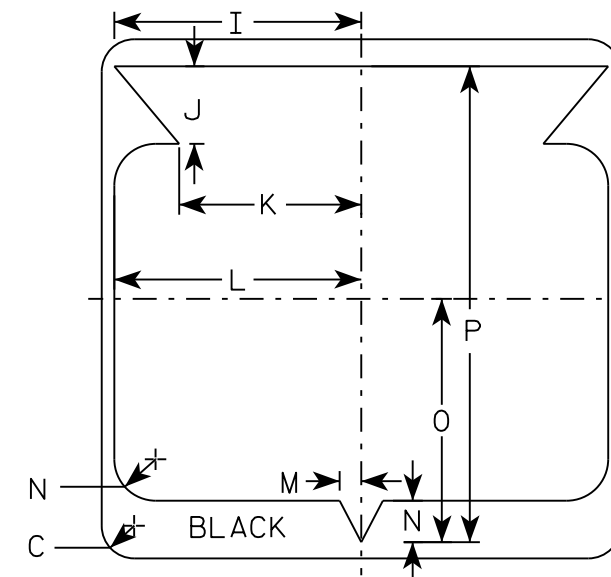
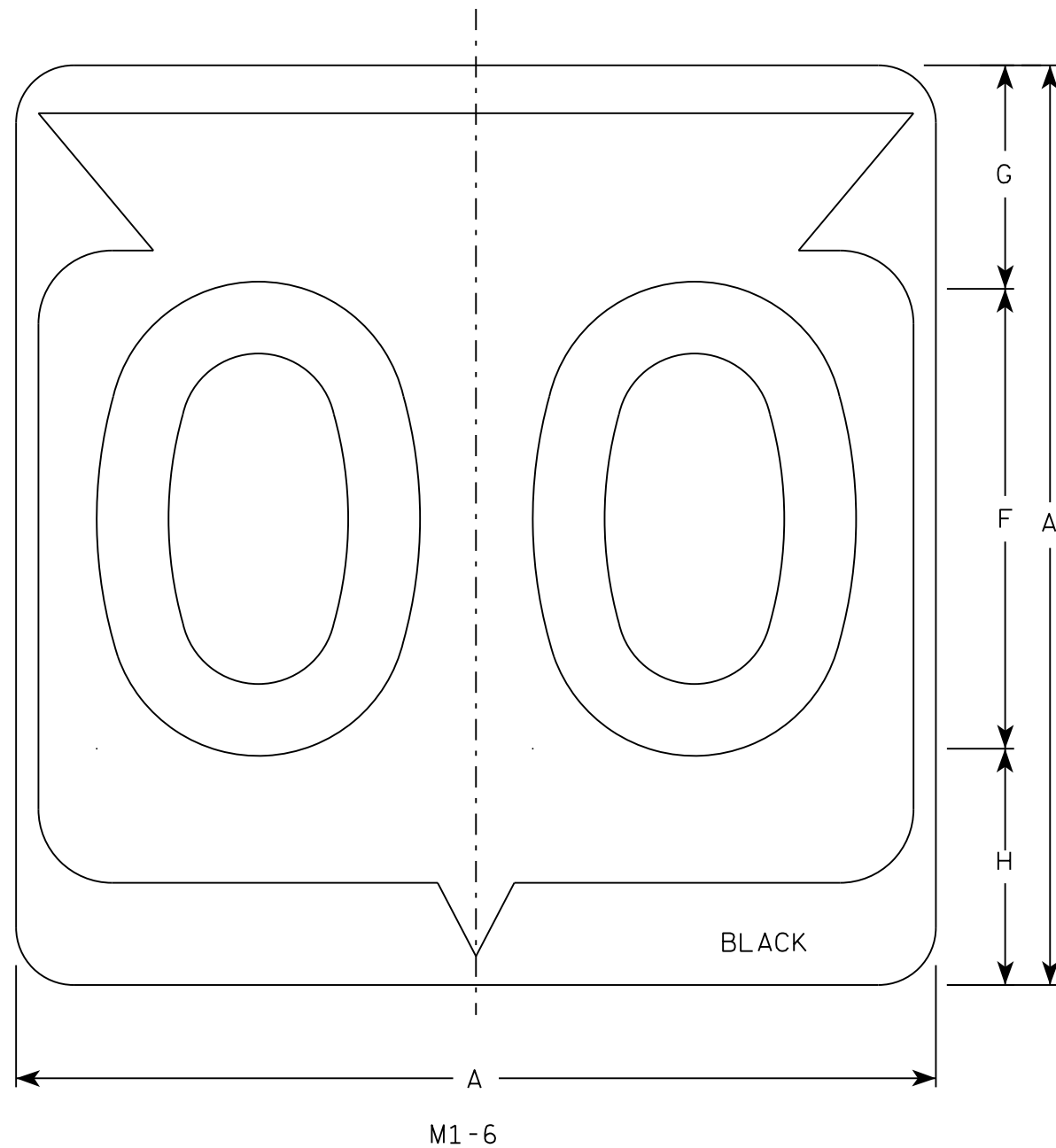

SIZE	A	B	C	D	E	F	G	H	I	J	K	L	M	N	O	P	Q	R	S	T	U	V	W	X	Y	Z	Area sq. ft.
1																											
2	24		1 1/2			12	5 1/2	6 1/2	10 1/4	2 1/2	8 7/8	11 1/2	1	1 7/8	11 1/4	21 7/8											4.0
3	36		2 1/4			18	8 3/4	9 1/4	15 3/8	5 3/8	12 5/8	17 1/8	1 1/2	2 7/8	16 7/8	33											9.0
4	36		2 1/4			18	8 3/4	9 1/4	15 3/8	5 3/8	12 5/8	17 1/8	1 1/2	2 7/8	16 7/8	33											9.0
5	36		2 1/4			18	8 3/4	9 1/4	15 3/8	5 3/8	12 5/8	17 1/8	1 1/2	2 7/8	16 7/8	33											9.0

STATE ROUTE MARKER
M1-6 FOR ASSEMBLIES

WISCONSIN DEPT OF TRANSPORTATION

APPROVED *Matthew R. Rauch*
for State Traffic Engineer

DATE 3/16/18 PLATE NO. M1-6.10

PROJECT NO: _____ HWY: _____ COUNTY: _____ SHEET NO: _____ E

7

7

NOTES

1. Sign is Type II - Type H
2. Color:
 - Background - See note 5
 - Message - See note 5
3. Message Series - C
4. Corners may be square or rounded when base material is plywood but borders shall be rounded as shown. When base material is metal, the corners and borders shall be rounded.
5. M2-1 Background - White
 Message - Black
 MB2-1 Background - Blue
 Message - White
 MK2-1 Background - Green
 Message - White
 MM2-1 Background - White
 Message - Green
 MN2-1 Background - Brown
 Message - White
 MP2-1 Background - White
 Message - Blue
 MR2-1 Background - Brown
 Message - Yellow

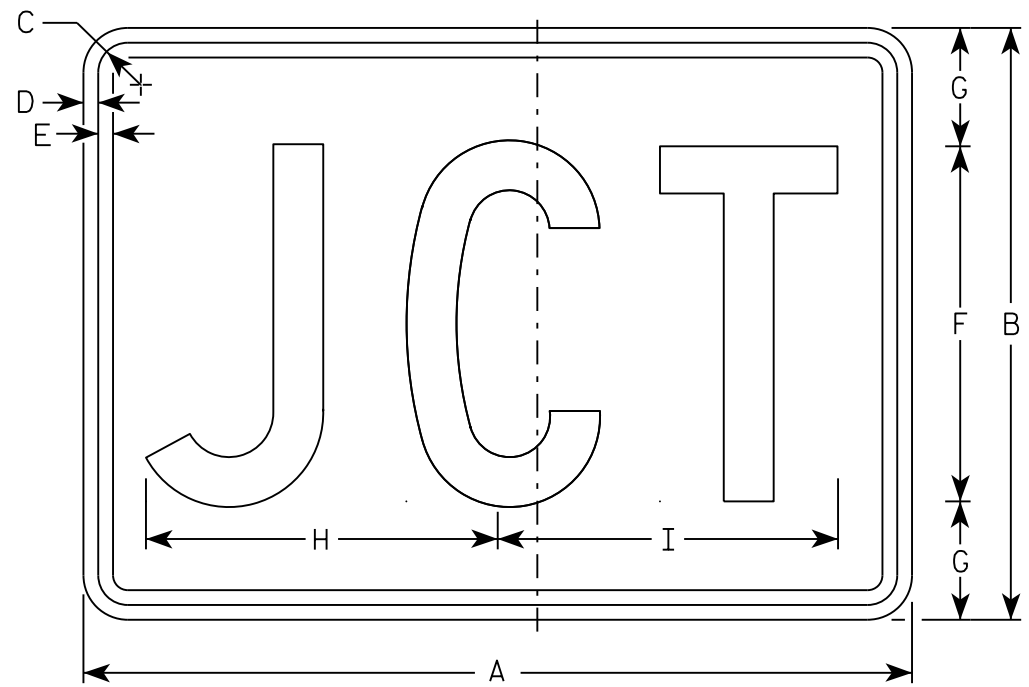

M2-1
MM2-1
MP2-1

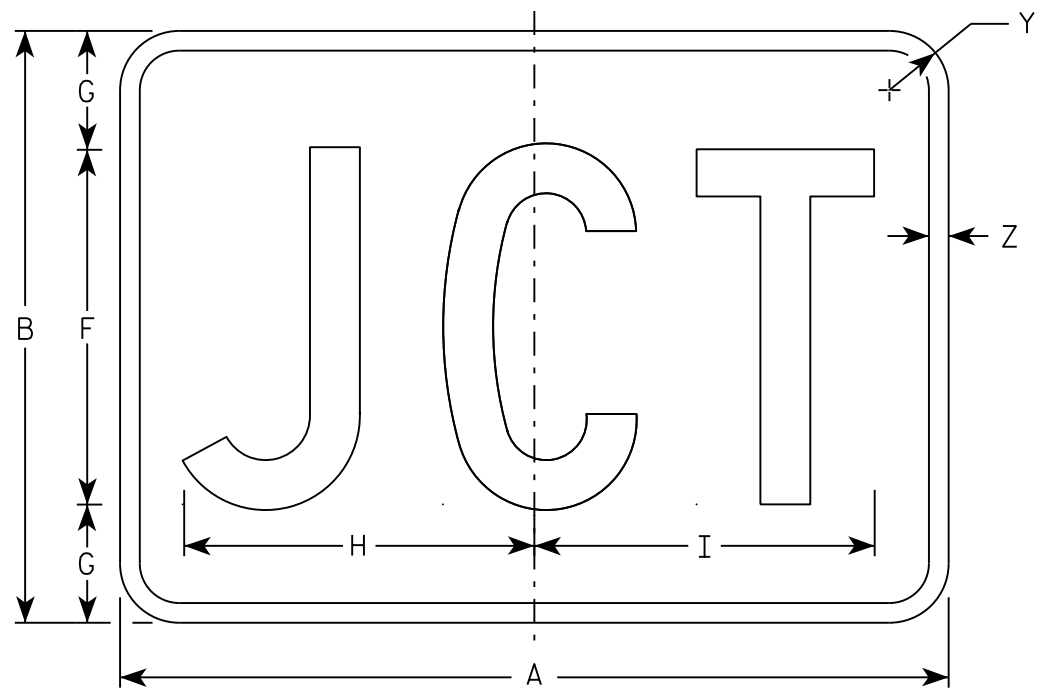

MB2-1
MK2-1
MN2-1
MR2-1

7

SIZE	A	B	C	D	E	F	G	H	I	J	K	L	M	N	O	P	Q	R	S	T	U	V	W	X	Y	Z	Area sq. ft.
1																											
2	21	15	1 1/8	3/8	3/8	9	3	8 7/8	8 5/8																1 1/2	1/2	2.20
3	30	21	1 1/8	3/8	3/8	13	4	12 7/8	12 3/8																1 1/2	1/2	4.40
4	30	21	1 1/8	3/8	3/8	13	4	12 7/8	12 3/8																1 1/2	1/2	4.40
5	30	21	1 1/8	3/8	3/8	13	4	12 7/8	12 3/8																1 1/2	1/2	4.40

STANDARD SIGN
M2-1

WISCONSIN DEPT OF TRANSPORTATION

APPROVED *Matthew R. Rauch*
For State Traffic Engineer

DATE 10/15/15 PLATE NO. M2-1.12

NOTES

- All Signs Type II - Type H
- Color:
 - Background - See note 5
 - Message - See note 5
- Message Series - C
- Corners may be square or rounded when base material is plywood but borders shall be rounded as shown. When base material is metal, the corners and borders shall be rounded.
- M3-1 thru M3-4 Background - White
 Message - Black
 MB3-1 thru MB3-4 Background - Blue
 Message - White
 MK3-1 thru MK3-4 Background - Green
 Message - White
 MM3-1 thru MM3-4 Background - White
 Message - Green
 MN3-1 thru MN3-4 Background - Brown
 Message - White
 MP3-1 thru MP3-4 Background - White
 Message - Blue
- Note the first letter of each direction is larger than the remainder of the message.

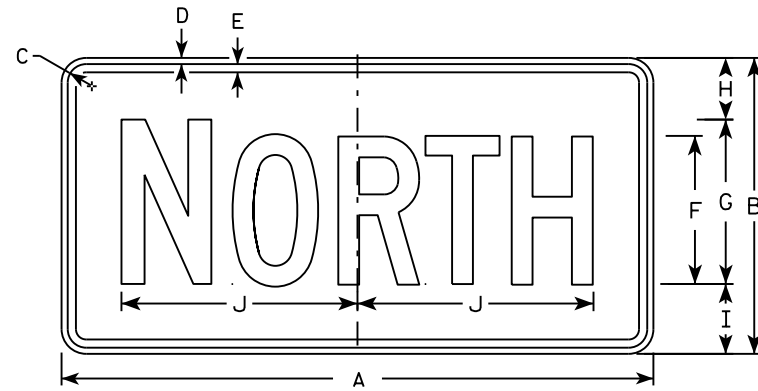

M3-1
MM3-1
MP3-1

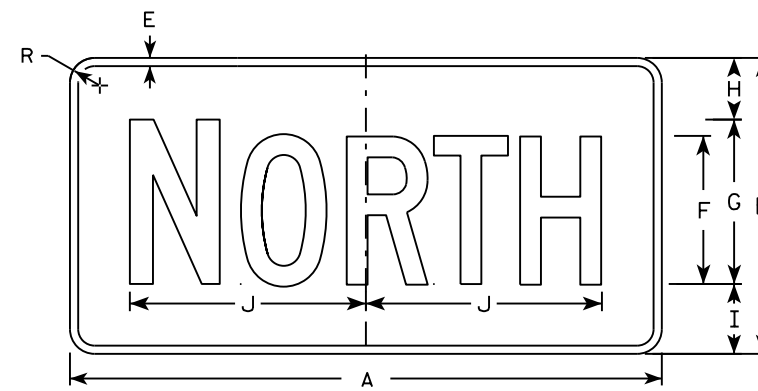

MB3-1
MK3-1
MN3-1

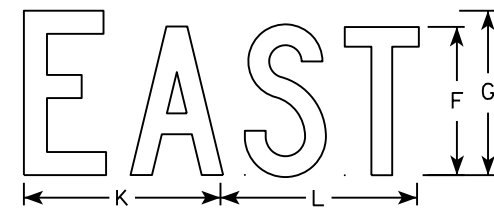

M3-2
MM3-2
MP3-2

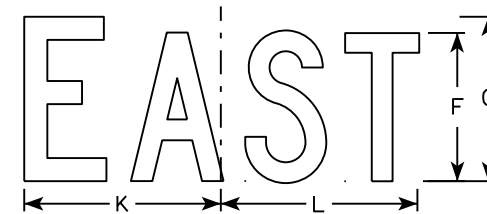

MB3-2
MK3-2
MN3-2

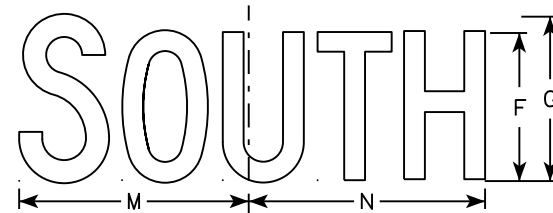

M3-3
MM3-3
MP3-3

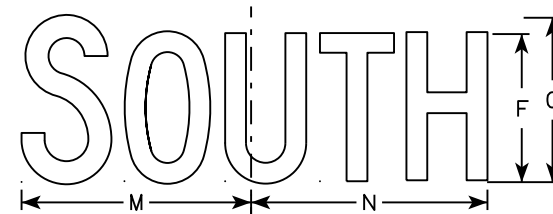

MB3-3
MK3-3
MN3-3

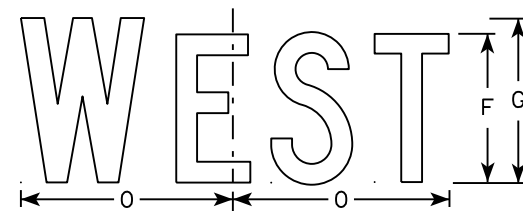

M3-4
MM3-4
MP3-4

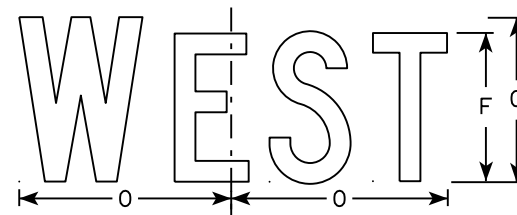

MB3-4
MK3-4
MN3-4

7

SIZE	A	B	C	D	E	F	G	H	I	J	K	L	M	N	O	P	Q	R	S	T	U	V	W	X	Y	Z	Area sq. ft.
1																											
2	24	12	1 1/8	3/8	3/8	6	7	2 1/4	2 3/4	10 1/4	7 7/8	8 3/8	10 1/4	9 3/4	8 3/4			1 1/2									2.00
3	36	18	1 1/8	3/8	1/2	9	10	3 3/4	4 1/4	14 3/8	12	12 1/8	14	14 1/8	13			1 1/2									4.5
4	36	18	1 1/8	3/8	1/2	9	10	3 3/4	4 1/4	14 3/8	12	12 1/8	14	14 1/8	13			1 1/2									4.5
5	36	18	1 1/8	3/8	1/2	9	10	3 3/4	4 1/4	14 3/8	12	12 1/8	14	14 1/8	13			1 1/2									4.5

STANDARD SIGNS
M3-1 thru M3-4
SERIES

WISCONSIN DEPT OF TRANSPORTATION

APPROVED *Matthew R. Rauch*
for State Traffic Engineer

DATE 10/15/15 PLATE NO. M3-1.14

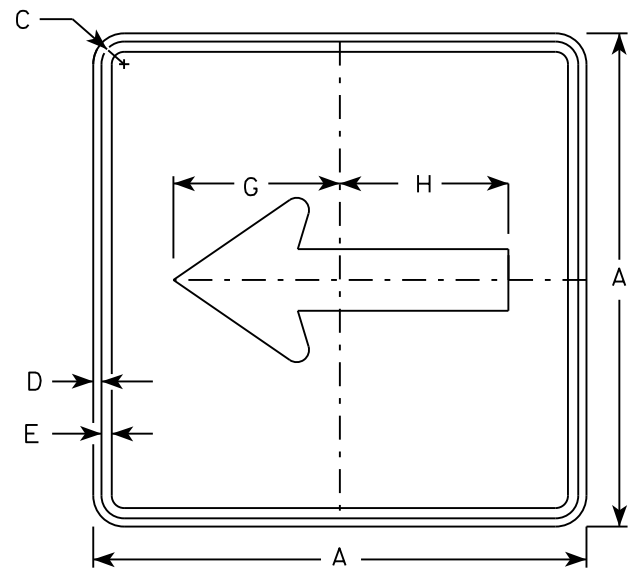

M6-1
MM6-1
M06-1
MP6-1

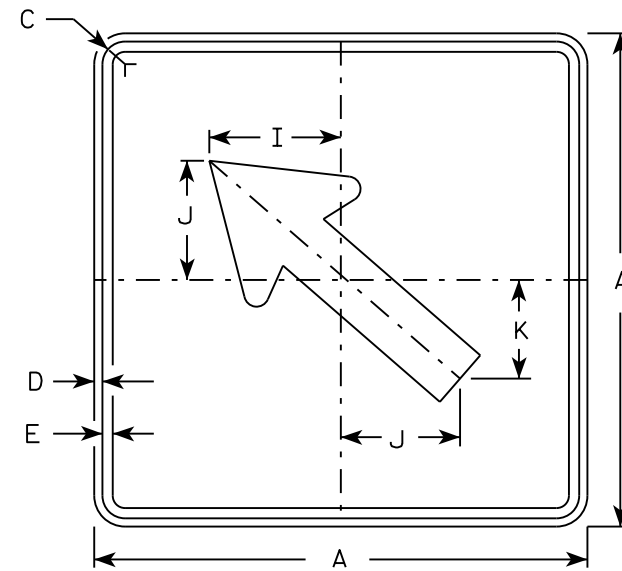

M6-2
MM6-2
M06-2
MP6-2

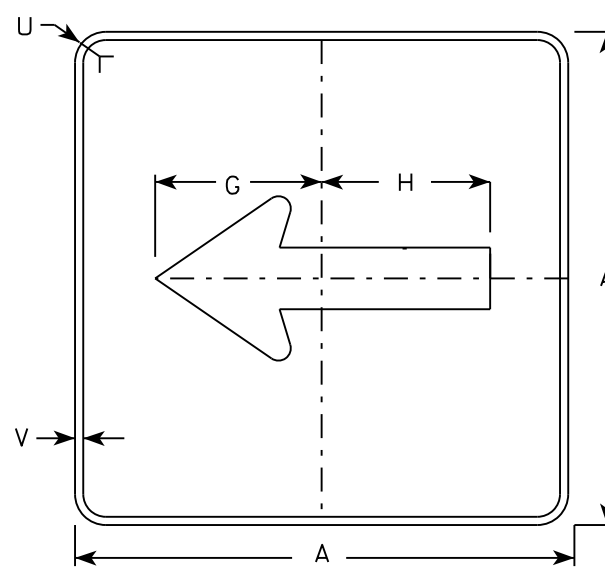

MB6-1
MK6-1
MN6-1
MR6-1

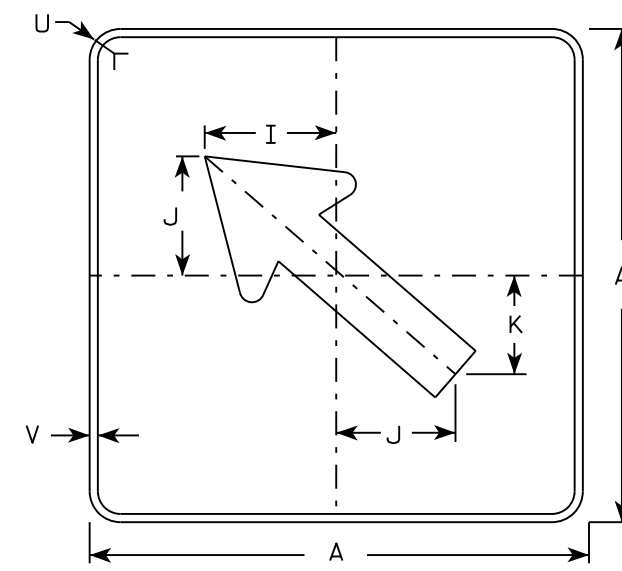

MB6-2
MK6-2
MN6-2
MR6-2

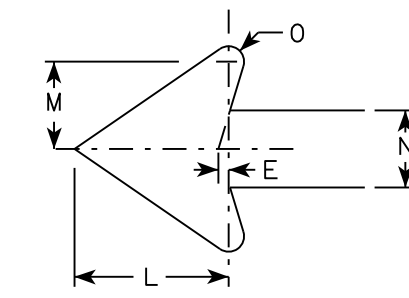

NOTES

- Signs are Type II - Type H except as Shown
- Color:
Background - See note 4
Message - See note 4
- Corners may be square or rounded when base material is plywood but borders shall be rounded as shown. When base material is metal, the corners and borders shall be rounded.
- M6-1 and M6-2 Background - White
Message - Black
MB6-1 and MB6-2 Background - Blue
Message - White
MK6-1 and MK6-2 Background - Green
Message - White
MM6-1 and MM6-2 Background - White
Message - Green
MN6-1 and MN6-2 Background - Brown
Message - White
M06-1 and M06-2 Background - Orange - Type F Reflective
Message - Black
MP6-1 and MP6-2 Background - White
Message - Blue
MR6-1 and MR6-2 Background - Brown
Message - Yellow

7

SIZE	A	B	C	D	E	F	G	H	I	J	K	L	M	N	O	P	Q	R	S	T	U	V	W	X	Y	Z	Area sq. ft.
1																											
2	21		1 1/8	3/8	3/8		7 1/2	7 1/8	5 5/8	5	4 1/4	5 1/4	3	2 5/8	1/2						1 1/2	1/2					3.06
3	30		1 3/8	1/2	5/8		10 3/4	10 1/4	8	7 1/4	6	7 1/2	4 1/4	3 3/4	3/4						1 7/8	1/2					6.25
4	30		1 3/8	1/2	5/8		10 3/4	10 1/4	8	7 1/4	6	7 1/2	4 1/4	3 3/4	3/4						1 7/8	1/2					6.25
5	30		1 3/8	1/2	5/8		10 3/4	10 1/4	8	7 1/4	6	7 1/2	4 1/4	3 3/4	3/4						1 7/8	1/2					6.25

STANDARD SIGN
M6-1 & M6-2
SERIES

WISCONSIN DEPT OF TRANSPORTATION

APPROVED *Matthew R. Rauch*
for State Traffic Engineer

DATE 10/15/15 PLATE NO. M6-1.15

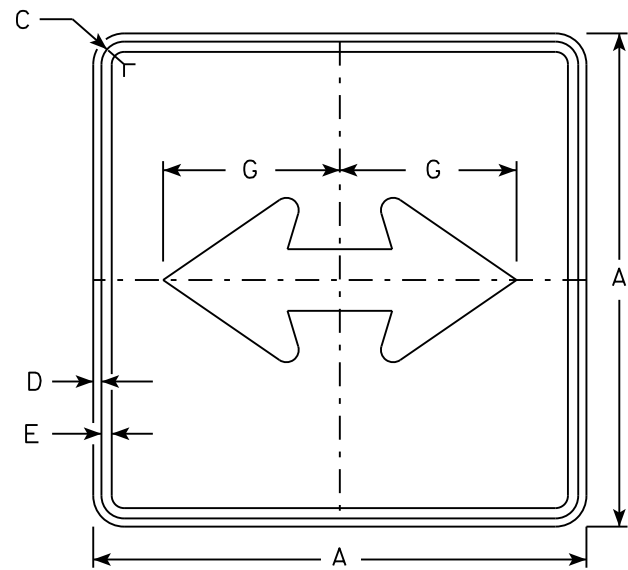

M6-4
MM6-4
M06-4
MP6-4

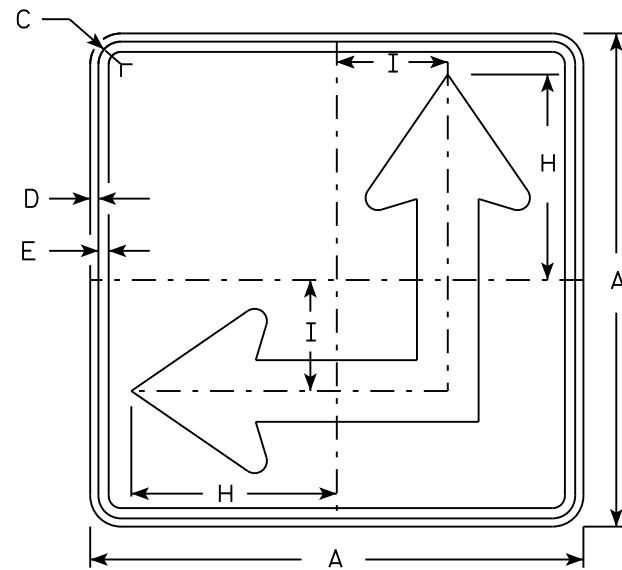

M6-6
MM6-6
M06-6
MP6-6

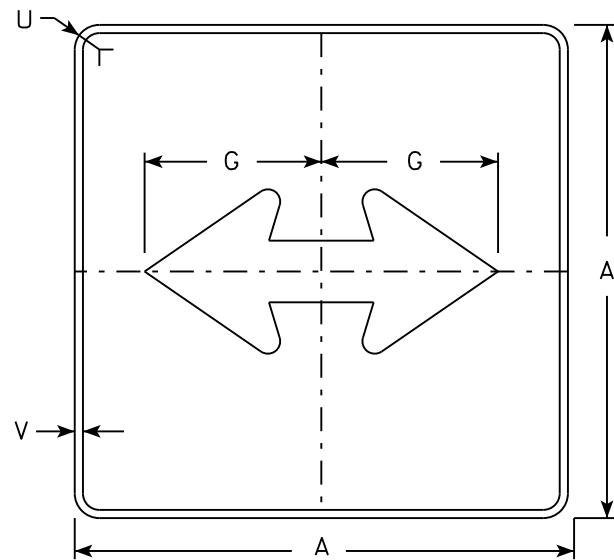

MB6-4
MK6-4
MN6-4
MR6-4

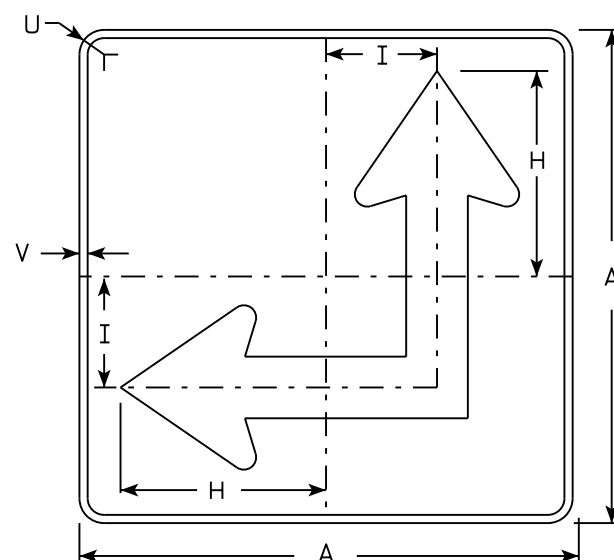

MB6-6
MK6-6
MN6-6
MR6-6

NOTES

- Signs are Type II - Type H except as Shown
- Color:
Background - See Note 4
Message - See Note 4
- Corners may be square or rounded when base material is plywood but borders shall be rounded as shown. When base material is metal, the corners and borders shall be rounded.
- M6-4 and M6-6 Background - White
Message - Black
MB6-4 and MB6-6 Background - Blue
Message - White
MK6-4 and MK6-6 Background - Green
Message - White
MM6-4 and MM6-6 Background - White
Message - Green
MN6-4 and MN6-6 Background - Brown
Message - White
M06-4 and M06-6 Background - Orange - Type F Reflective
Message - Black
MP6-4 and MP6-6 Background - White
Message - Blue
MR6-4 and MR6-6 Background - Brown
Message - Yellow
- M6-6R same as M6-6L except arrow points ahead and right.

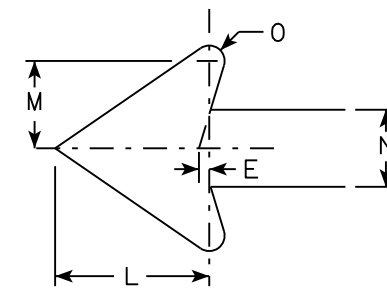

7

SIZE	A	B	C	D	E	F	G	H	I	J	K	L	M	N	O	P	Q	R	S	T	U	V	W	X	Y	Z	Area sq. ft.
1																											
2	21		1 1/8	3/8	3/8		7 1/2	8 3/4	4 1/4			5 1/4	3	2 5/8	1/2						1 1/2	1/2					3.06
3	30		1 3/8	1/2	5/8		10 3/4	12 1/2	6 3/4			7 1/2	4 1/4	3 3/4	3/4						1 7/8	1/2					6.25
4	30		1 3/8	1/2	5/8		10 3/4	12 1/2	6 3/4			7 1/2	4 1/4	3 3/4	3/4						1 7/8	1/2					6.25
5	30		1 3/8	1/2	5/8		10 3/4	12 1/2	6 3/4			7 1/2	4 1/4	3 3/4	3/4						1 7/8	1/2					6.25

STANDARD SIGN
M6-4 & M6-6
SERIES

WISCONSIN DEPT OF TRANSPORTATION

APPROVED *Matthew R. Rauch*
for State Traffic Engineer

DATE 10/15/15 PLATE NO. M6-4.10

NOTES

1. Sign is Type II - Type H Reflective - reference WIS DOT Standard Specification for HIGHWAY and STRUCTURE CONSTRUCTION latest edition.
2. Color:
Background - Red
Message - White
3. Message Series - C

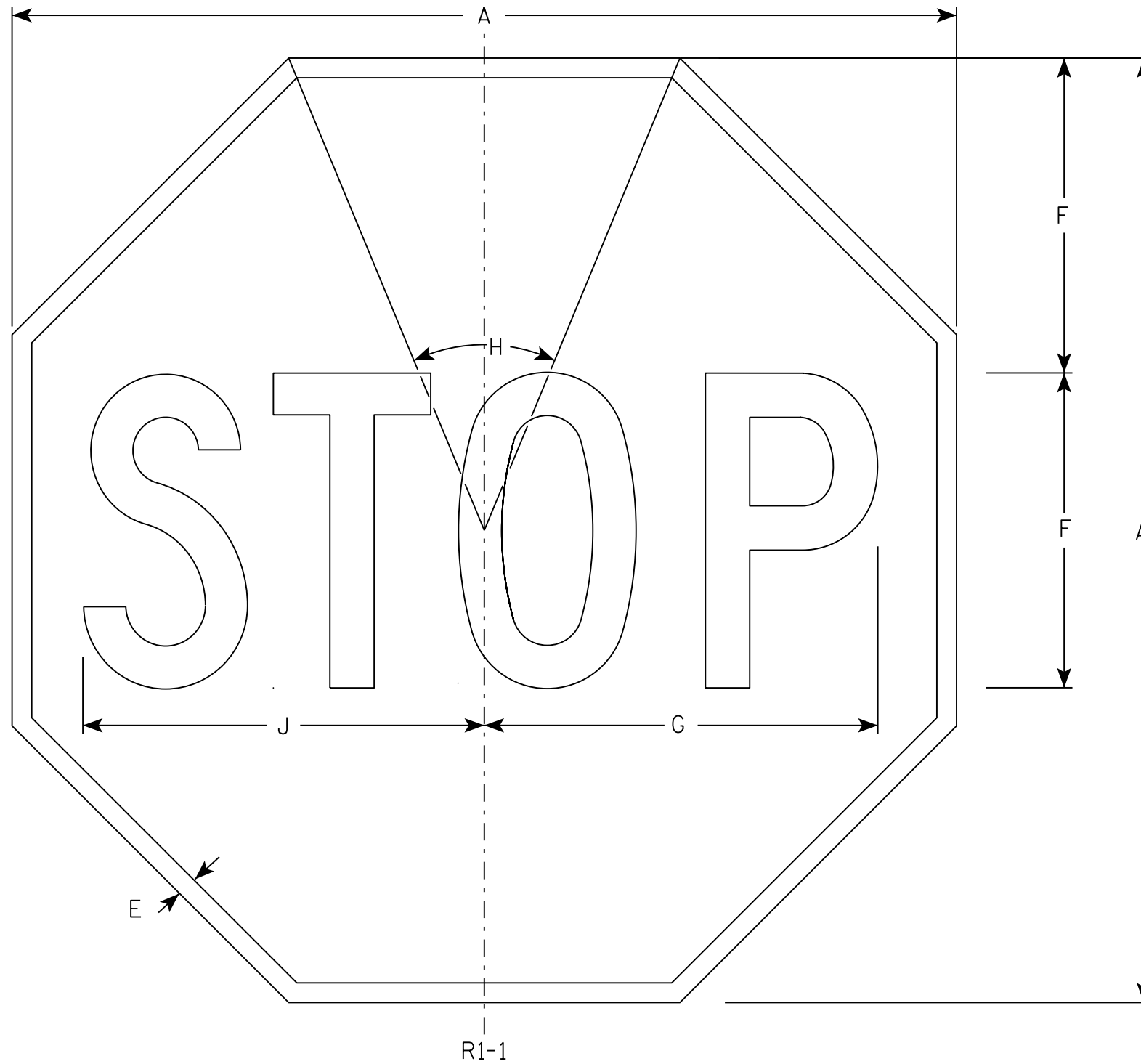

7

7

SIZE	A	B	C	D	E	F	G	H	I	J	K	L	M	N	O	P	Q	R	S	T	U	V	W	X	Y	Z	Area sq. ft.
1	30				5/8	10	12 1/2	45°		12 3/4																	5.18
2S	30				5/8	10	12 1/2	45°		12 3/4																	5.18
2M	36				3/4	12	15	45°		15 3/8																	7.46
3	36				3/4	12	15	45°		15 3/8																	7.46
4	48				1	16	20	45°		20 1/2																	13.25
5	48				1	16	20	45°		20 1/2																	13.25
6	18				3/8	6	7 3/4	45°		7 3/4																	1.86
7	12				1/4	4	5	45°		5 1/8																	0.78

PROJECT NO: _____ HWY: _____ COUNTY: _____ SHEET NO: _____ **E**

STANDARD SIGN
R1-1

WISCONSIN DEPT OF TRANSPORTATION

APPROVED *Matthew R. Rauch*
for State Traffic Engineer

DATE 11/12/15 PLATE NO. R1-1.13

NOTES

1. Sign is Type II - Type H Reflective
2. Color:
Background - White
Message - Black
3. Message Series - C
4. Corners may be square or rounded when base material is plywood but borders shall be rounded as shown. When base material is metal, the corners and borders shall be rounded.
5. Substitute appropriate numerals to nearest quarter mile and optically adjust spacing to achieve proper balance.

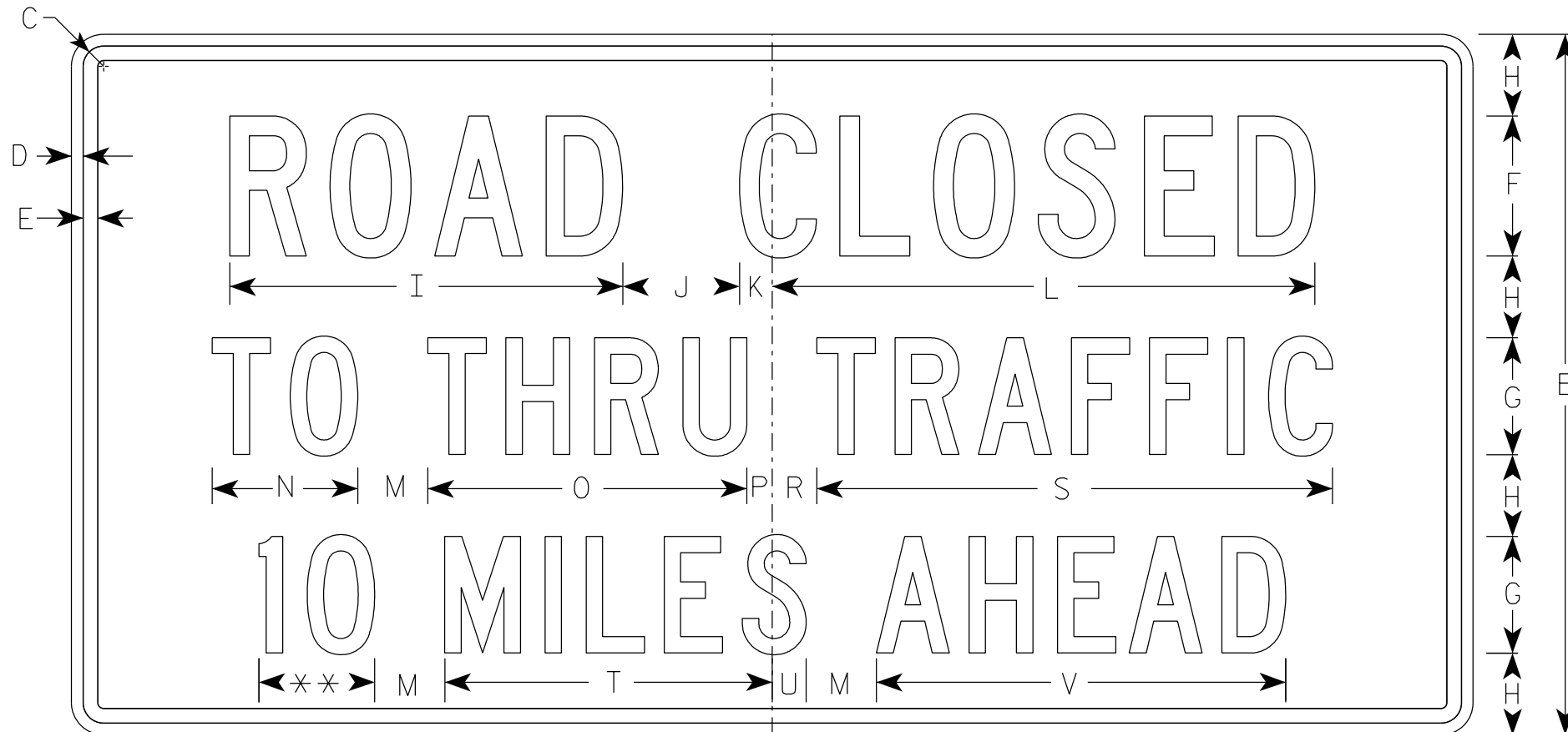

R11-3

** See Note 5

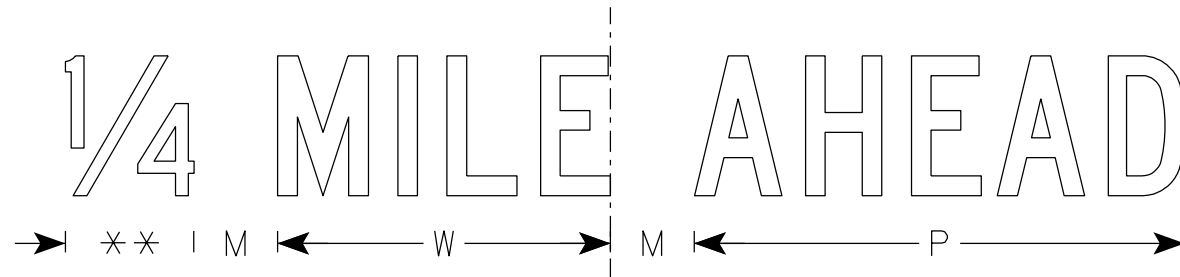

SIZE	A	B	C	D	E	F	G	H	I	J	K	L	M	N	O	P	Q	R	S	T	U	V	W	X	Y	Z	Area sq. ft.	
1	36	18	1 1/4	3/8	3/8	4	3	2	11 1/4	3	1 1/8	15 3/8	2	3 3/4	8 1/4	5/8		1 3/8	13 1/4	8 3/8	7/8	10 1/2	7 1/8				4.5	
2S	60	30	1 3/8	1/2	5/8	6	5	3 1/2	16 7/8	5	1 3/8	23 1/4	3	6 1/4	13 5/8	1 1/8		1 7/8	22 1/8	14	1 1/2	17 1/2	11 7/8				12.5	
2M	60	30	1 3/8	1/2	5/8	6	5	3 1/2	16 7/8	5	1 3/8	23 1/4	3	6 1/4	13 5/8	1 1/8		1 7/8	22 1/8	14	1 1/2	17 1/2	11 7/8				12.5	
3																												
4																												
5																												

STANDARD SIGN
R11-3

WISCONSIN DEPT OF TRANSPORTATION

APPROVED *Matthew R. Rauch*
for State Traffic Engineer

DATE 6/14/2021 PLATE NO. R11-3.9

NOTES

1. Sign is Type II - Type H Reflective - reference WIS DOT Standard Specification for HIGHWAY and STRUCTURE CONSTRUCTION latest edition.
2. Color:
Background - White
Message - Black
3. Message Series - C
4. Corners may be square or rounded when base material is plywood but borders shall be rounded as shown. When base material is metal, the corners and borders shall be rounded.

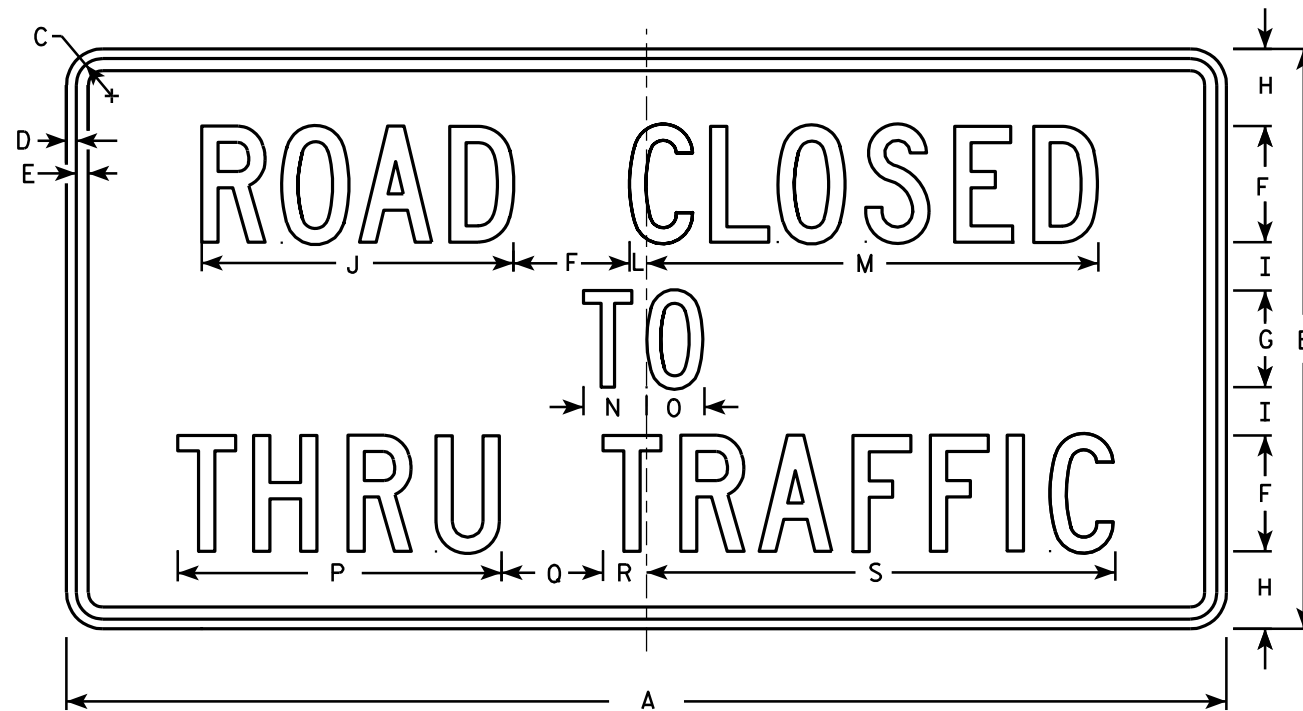

R11-4

7

7

SIZE	A	B	C	D	E	F	G	H	I	J	K	L	M	N	O	P	Q	R	S	T	U	V	W	X	Y	Z	Area sq. ft.
1																											
2S	60	30	1 3/8	1/2	5/8	6	5	4	2 1/2	16 1/8		7/8	23 3/8	3 1/4	3	16 3/4	5 1/4	2 1/4	24 1/4								12.5
2M	60	30	1 3/8	1/2	5/8	6	5	4	2 1/2	16 1/8		7/8	23 3/8	3 1/4	3	16 3/4	5 1/4	2 1/4	24 1/4								12.5
3																											
4																											
5																											

STANDARD SIGN
R11 - 4

WISCONSIN DEPT OF TRANSPORTATION

APPROVED *Matthew R. Raush*
for State Traffic Engineer

DATE 4/1/11 PLATE NO. R11-4.3

PROJECT NO: _____ HWY: _____ COUNTY: _____ SHEET NO: _____ E

NOTES

1. Sign is Type II - Type F Reflective - reference WIS DOT Standard Specification for HIGHWAY and STRUCTURE CONSTRUCTION latest edition.
2. Color:
Background - Yellow
Message - Black
3. Corners may be square or rounded when base material is plywood but borders shall be rounded as shown. When base material is metal, the corners and borders shall be rounded.
4. W1-2L is the same as W1-2R except the arrow is reversed along the vertical centerline.

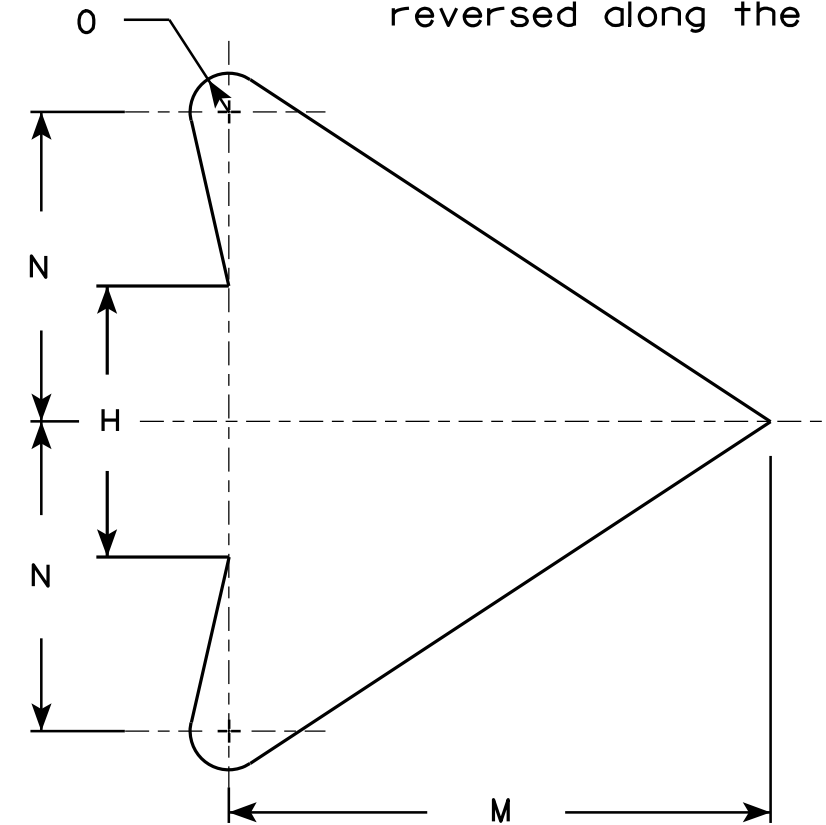
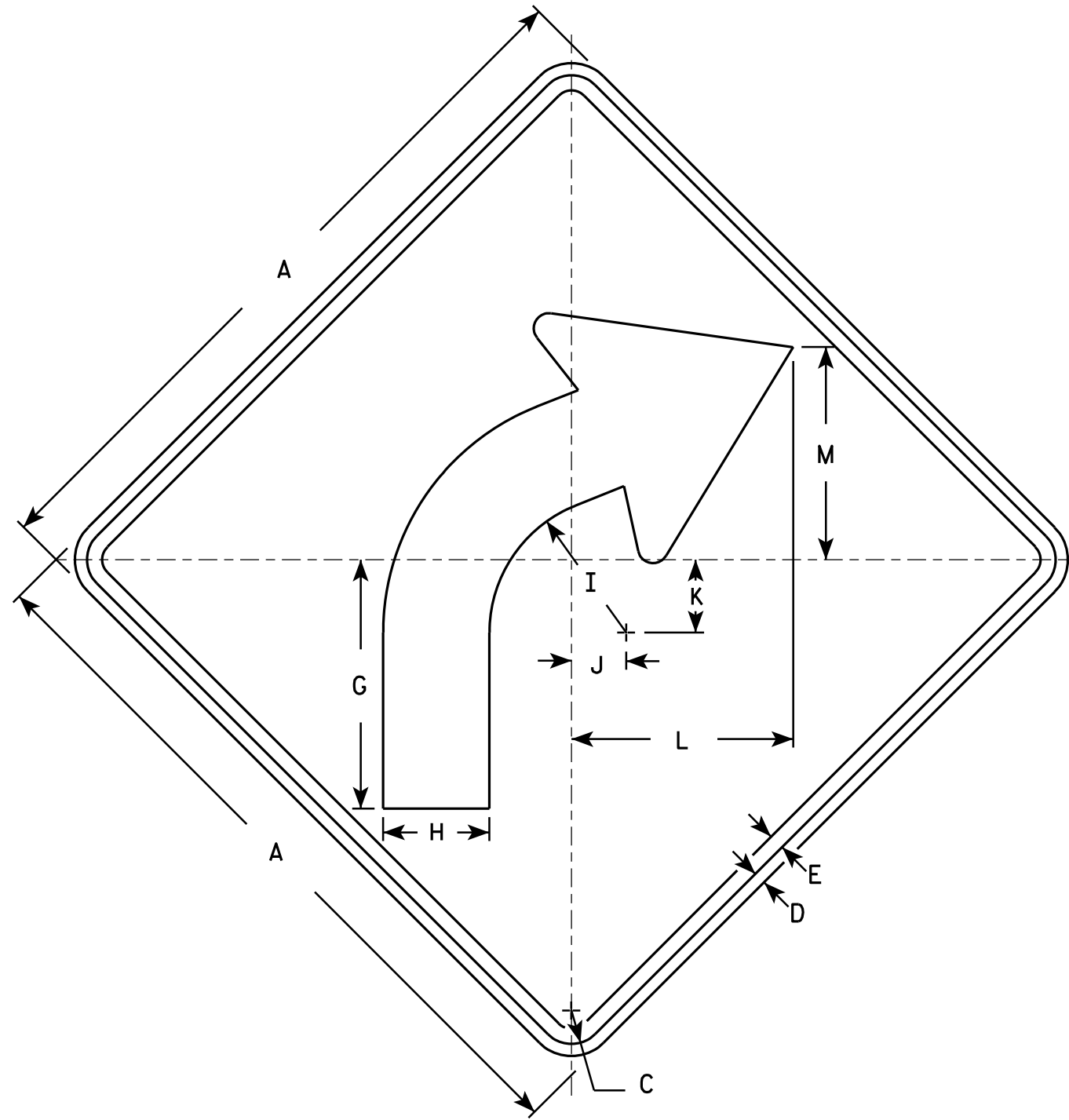

ARROW DETAIL

W1-2R

SIZE	A	B	C	D	E	F	G	H	I	J	K	L	M	N	O	P	Q	R	S	T	U	V	W	X	Y	Z	Area sq. ft.
1	24		1 1/8	3/8	1/2		8 1/4	3 1/2	4 1/2	1 3/4	2 3/8	7 1/4	7	4	1/2												4.0
2S	30		1 3/8	1/2	5/8		10 1/4	4 3/8	5 5/8	2 1/4	3	9 1/8	8 3/4	5	5/8												6.25
2M	36		1 5/8	5/8	3/4		12 3/8	5 1/4	6 3/4	2 5/8	3 1/2	10 7/8	10 1/2	6	3/4												9.0
3	36		1 5/8	5/8	3/4		12 3/8	5 1/4	6 3/4	2 5/8	3 1/2	10 7/8	10 1/2	6	3/4												9.0
4	36		1 5/8	5/8	3/4		12 3/8	5 1/4	6 3/4	2 5/8	3 1/2	10 7/8	10 1/2	6	3/4												9.0
5	48		2 1/4	3/4	1		16 1/2	7	9	3 1/2	4 5/8	14 1/2	14	8	1												16.0

**STANDARD SIGN
W1-2**

WISCONSIN DEPT OF TRANSPORTATION

APPROVED *Matthew R. Rauch*
For State Traffic Engineer

DATE 5/15/12 PLATE NO. W1-2.10

PROJECT NO: _____ HWY: _____ COUNTY: _____ SHEET NO: **E**

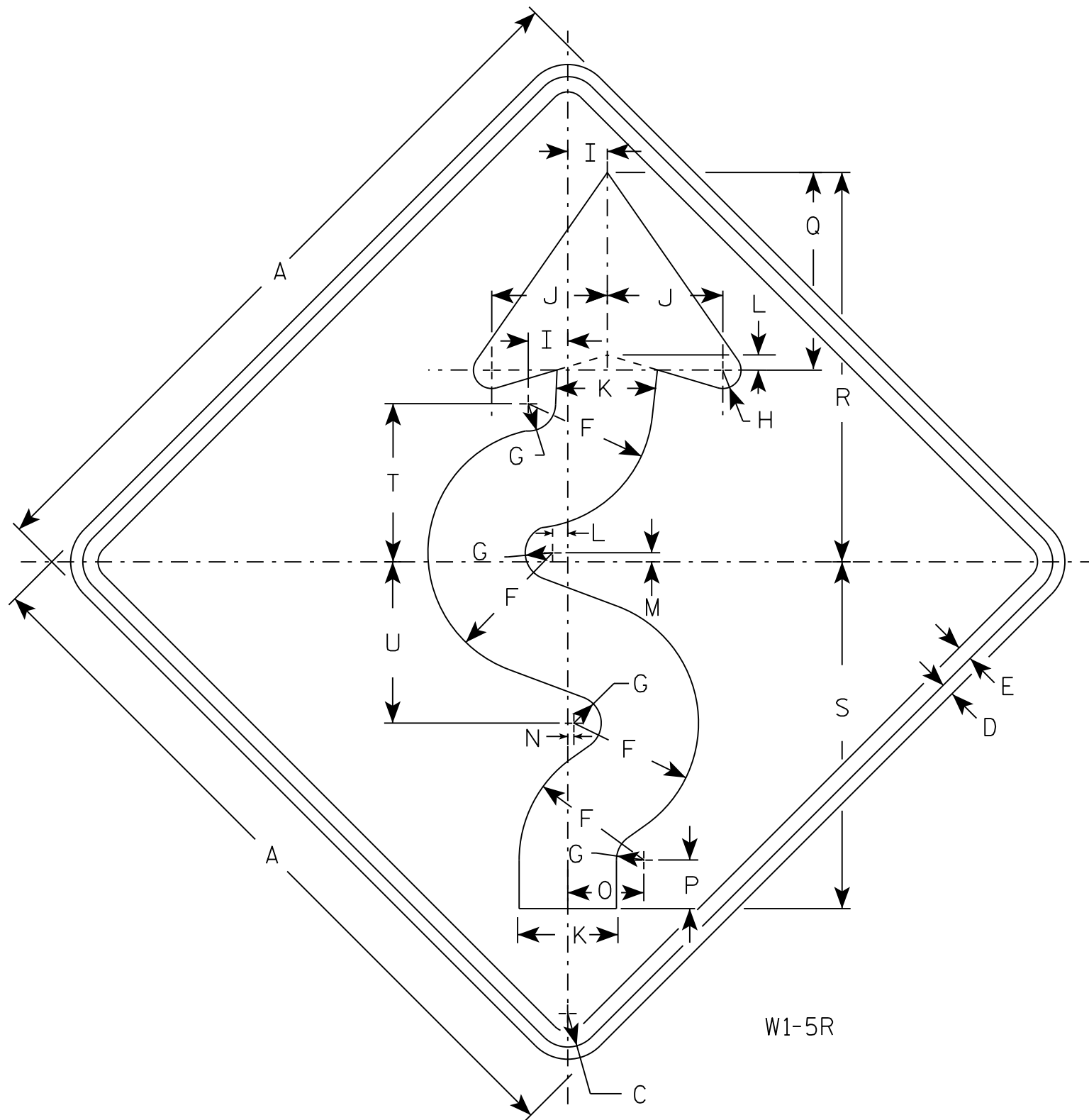

NOTES

1. Sign is Type II - Type F Reflective
2. Color:
Background - Yellow
Message - Black
3. W1-5L is the same as W1-5R except the arrow is reversed along the vertical centerline.
4. If used with W13-1 of 30 MPH or less, use 36" sign for Size 2S.

7

W1-5R

SIZE	A	B	C	D	E	F	G	H	I	J	K	L	M	N	O	P	Q	R	S	T	U	V	W	X	Y	Z	Area sq. ft.
1	24		1 1/8	3/8	1/2	4 1/8	7/8	5/8	1 1/4	3 3/4	3 1/4	1/2	1/4	1/8	2 1/2	1 5/8	6 1/2	12 3/4	11 3/8	5 1/4	5 1/4						4.0
2S	30		1 3/8	1/2	5/8	5 1/8	1 1/8	3/4	1 5/8	4 3/4	4 1/8	5/8	3/8	1/4	3 1/8	2	8 1/8	16	14 1/4	6 1/2	6 5/8						6.25
2M	36		1 5/8	5/8	3/4	6 1/4	1 3/8	1	1 7/8	5 5/8	4 7/8	3/4	3/8	1/4	3 3/4	2 7/8	9 3/4	19 1/8	17 1/8	7 3/4	7 7/8						9.0
3	36		1 5/8	5/8	3/4	6 1/4	1 3/8	1	1 7/8	5 5/8	4 7/8	3/4	3/8	1/4	3 3/4	2 7/8	9 3/4	19 1/8	17 1/8	7 3/4	7 7/8						9.0
4	36		1 5/8	5/8	3/4	6 1/4	1 3/8	1	1 7/8	5 5/8	4 7/8	3/4	3/8	1/4	3 3/4	2 7/8	9 3/4	19 1/8	17 1/8	7 3/4	7 7/8						9.0
5	48		2 1/4	3/4	1	8 1/4	1 3/4	1 1/4	2 1/2	7 1/2	6 1/2	1	1/2	3/8	5	3 1/4	13	25 1/2	22 3/4	10 3/8	10 1/2						16.0

STANDARD SIGN

W1-5

WISCONSIN DEPT OF TRANSPORTATION

APPROVED *Matthew R. Rauch*
for State Traffic Engineer

DATE 8/1/16 PLATE NO. W1-5.9

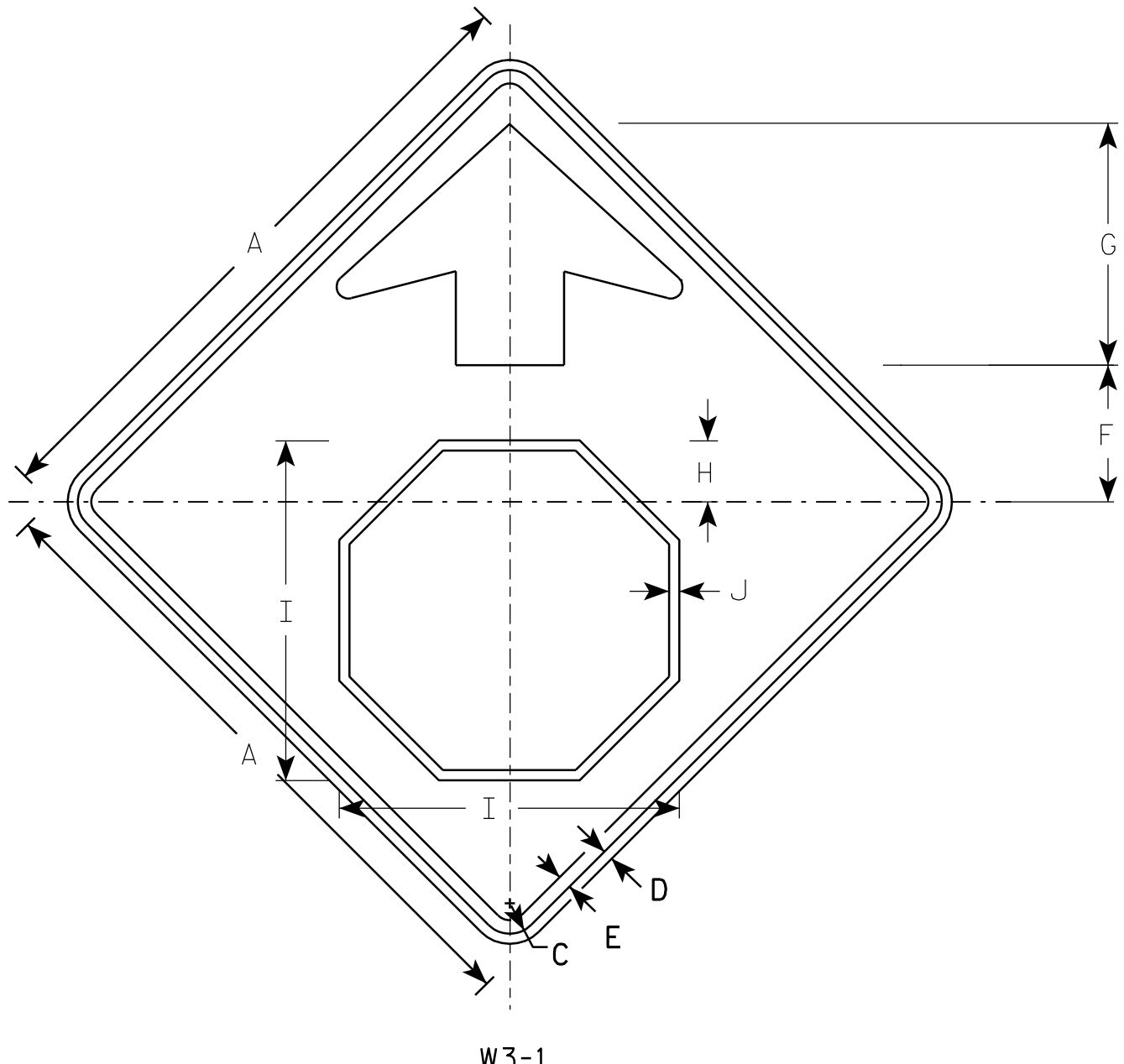

NOTES

1. All Signs Type II - Type F Reflective - reference WIS DOT Standard Specification for HIGHWAY and STRUCTURE CONSTRUCTION latest edition.
2. Color:
 Background - YELLOW
 Arrow & Border - BLACK
 Stop Symbol - WHITE BORDER ON RED BACKGROUND

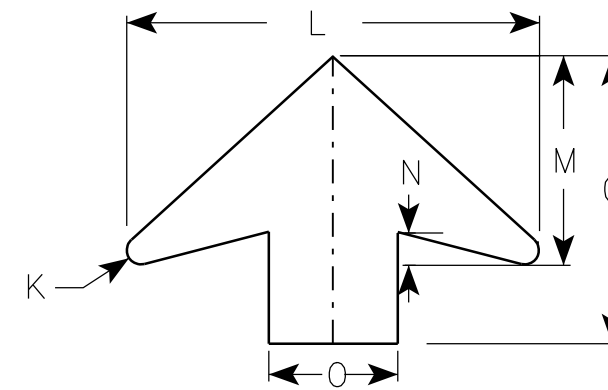

ARROW DETAIL

7

7

SIZE	A	B	C	D	E	F	G	H	I	J	K	L	M	N	O	P	Q	R	S	T	U	V	W	X	Y	Z	Area sq. ft.
1	30		1 3/8	1/2	5/8	6 1/4	11 1/4	2 7/8	15 3/4	1/2	1/2	16	8	1 1/4	5												6.25
2S	36		1 5/8	5/8	3/4	7 1/2	13 1/2	3 1/2	19	5/8	5/8	19 1/4	9 3/4	1 5/8	6												9.0
2M	36		1 5/8	5/8	3/4	7 1/2	13 1/2	3 1/2	19	5/8	5/8	19 1/4	9 3/4	1 5/8	6												9.0
3	36		1 5/8	5/8	3/4	7 1/2	13 1/2	3 1/2	19	5/8	5/8	19 1/4	9 3/4	1 5/8	6												9.0
4	48		2 1/4	3/4	1	10	17 7/8	4 1/2	25 1/8	3/4	7/8	25 5/8	13	2	8												16.0
5	48		2 1/4	3/4	1	10	17 7/8	4 1/2	25 1/8	3/4	7/8	25 5/8	13	2	8												16.0

STANDARD SIGN
W3-1

WISCONSIN DEPT OF TRANSPORTATION

APPROVED *Matthew R. Rauch*
for State Traffic Engineer

DATE 6/7/10 PLATE NO. W3-1.12

PROJECT NO: _____ SHEET NO: _____ E

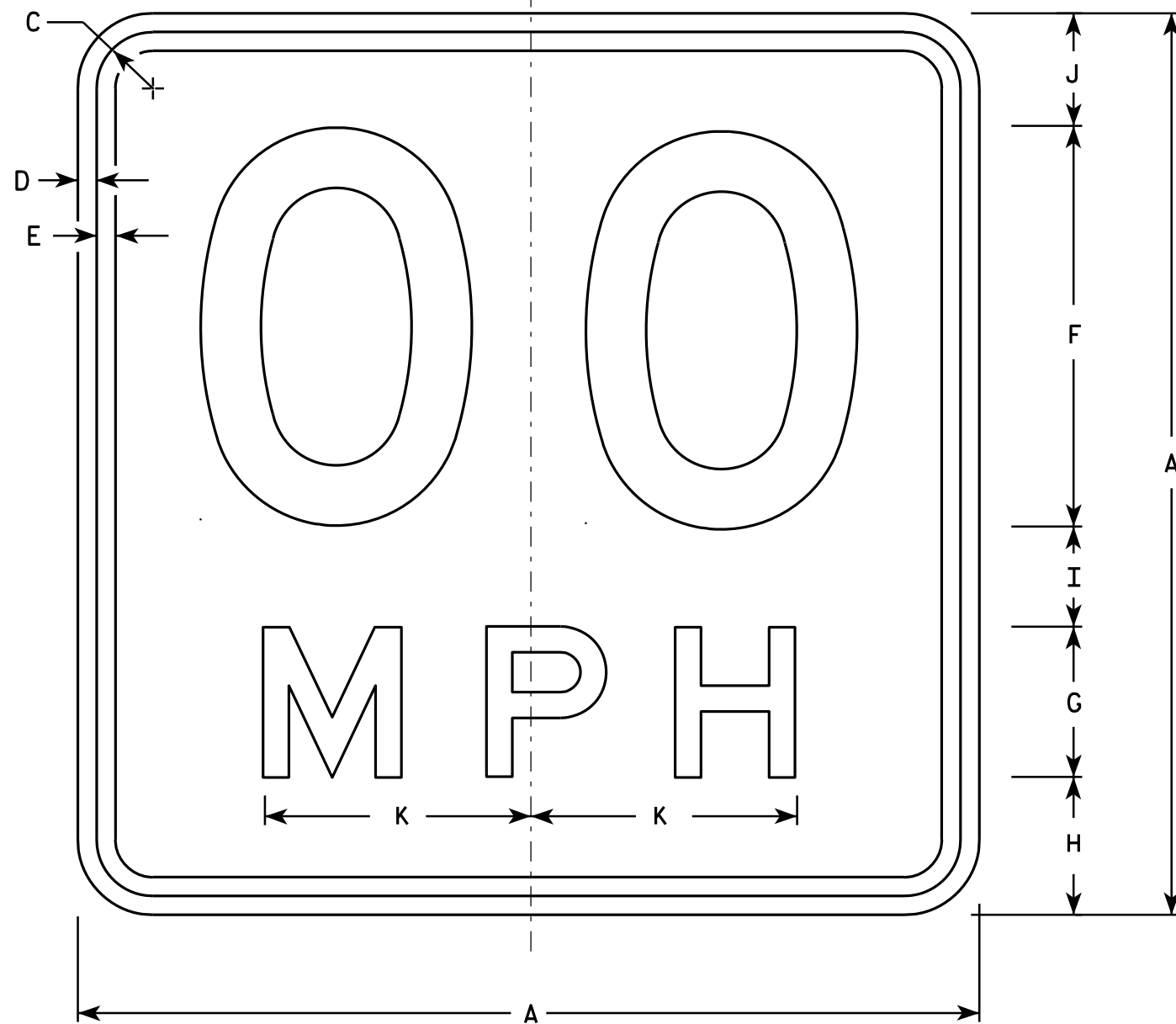

NOTES

1. Sign is Type II - Type F Reflective - reference WIS DOT Standard Specification for HIGHWAY and STRUCTURE CONSTRUCTION latest edition.
2. Color:
Background - Yellow
Message - Black
3. Message Series - See Note 6
4. Corners may be square or rounded when base material is plywood but borders shall be rounded as shown. When base material is metal, the corners and borders shall be rounded.
5. Substitute appropriate numerals and optically space about centerline to achieve proper balance.
6. Line 1 is Series D
Line 2 is Series E

W13-1

* For 30" x 30" Warning Signs, use 18" x 18" W13-1 signs.
For 36" x 36" Warning Signs, use 24" x 24" W13-1 signs.

SIZE	A	B	C	D	E	F	G	H	I	J	K	L	M	N	O	P	Q	R	S	T	U	V	W	X	Y	Z	Area sq. ft.
1	18		1 1/8	3/8	3/8	8	3	2 3/4	2	2 1/4	5 3/8																2.25
* 2S	18		1 1/8	3/8	3/8	8	3	2 3/4	2	2 1/4	5 3/8																2.25
* 2M	18		1 1/8	3/8	3/8	8	3	2 3/4	2	2 1/4	5 3/8																2.25
3	24		1 1/8	3/8	1/2	10	4	4	2 3/4	3 1/4	6 5/8																4.00
4	36		1 5/8	5/8	3/4	16	6	5 1/2	4	4 1/2	10 5/8																9.00
5	36		1 5/8	5/8	3/4	16	6	5 1/2	4	4 1/2	10 5/8																9.00

STANDARD SIGN
W13-1

WISCONSIN DEPT OF TRANSPORTATION
APPROVED *Matthew R. Rauch*
For State Traffic Engineer

DATE 5/31/12 PLATE NO. W13-1.16

PROJECT NO:

HWY:

COUNTY:

SHEET NO:

E

NOTES

1. Sign is Type II - Type F Reflective
2. Color:
Background - Orange
Message - Black
3. Message Series - C
4. Corners may be square or rounded when base material is plywood but borders shall be rounded as shown. When base material is metal, the corners and borders shall be rounded.

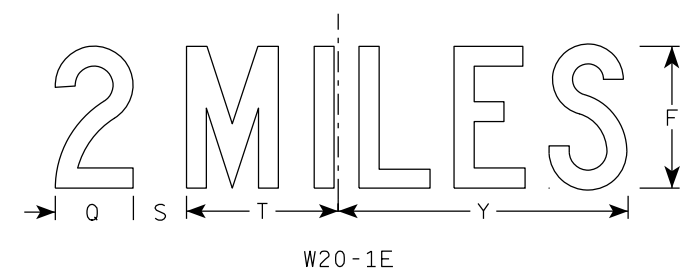
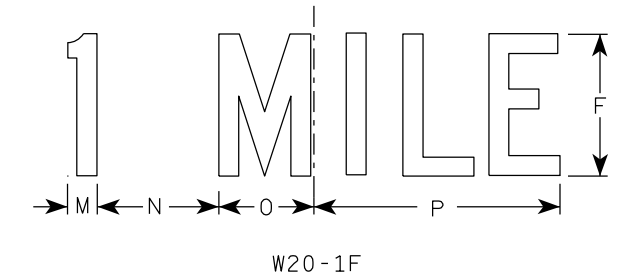
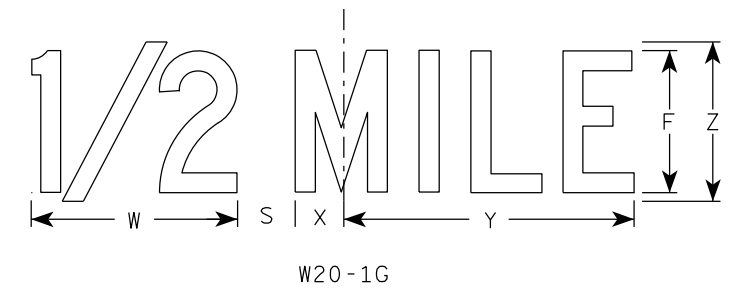
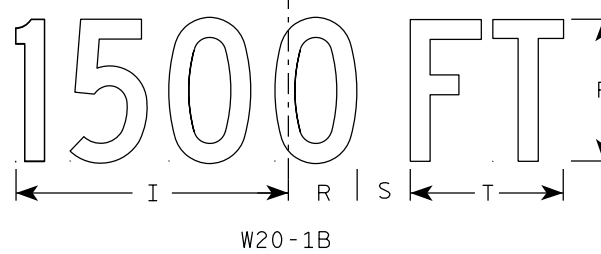
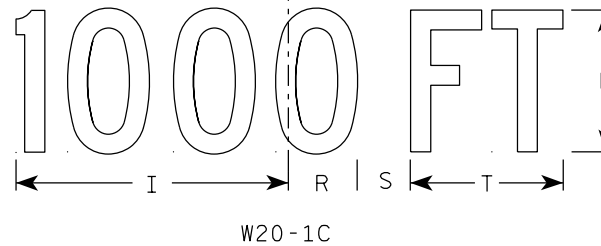
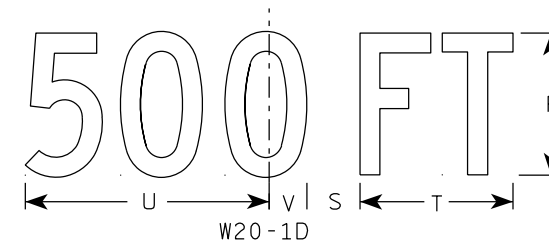
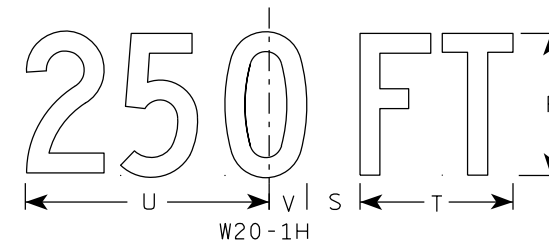
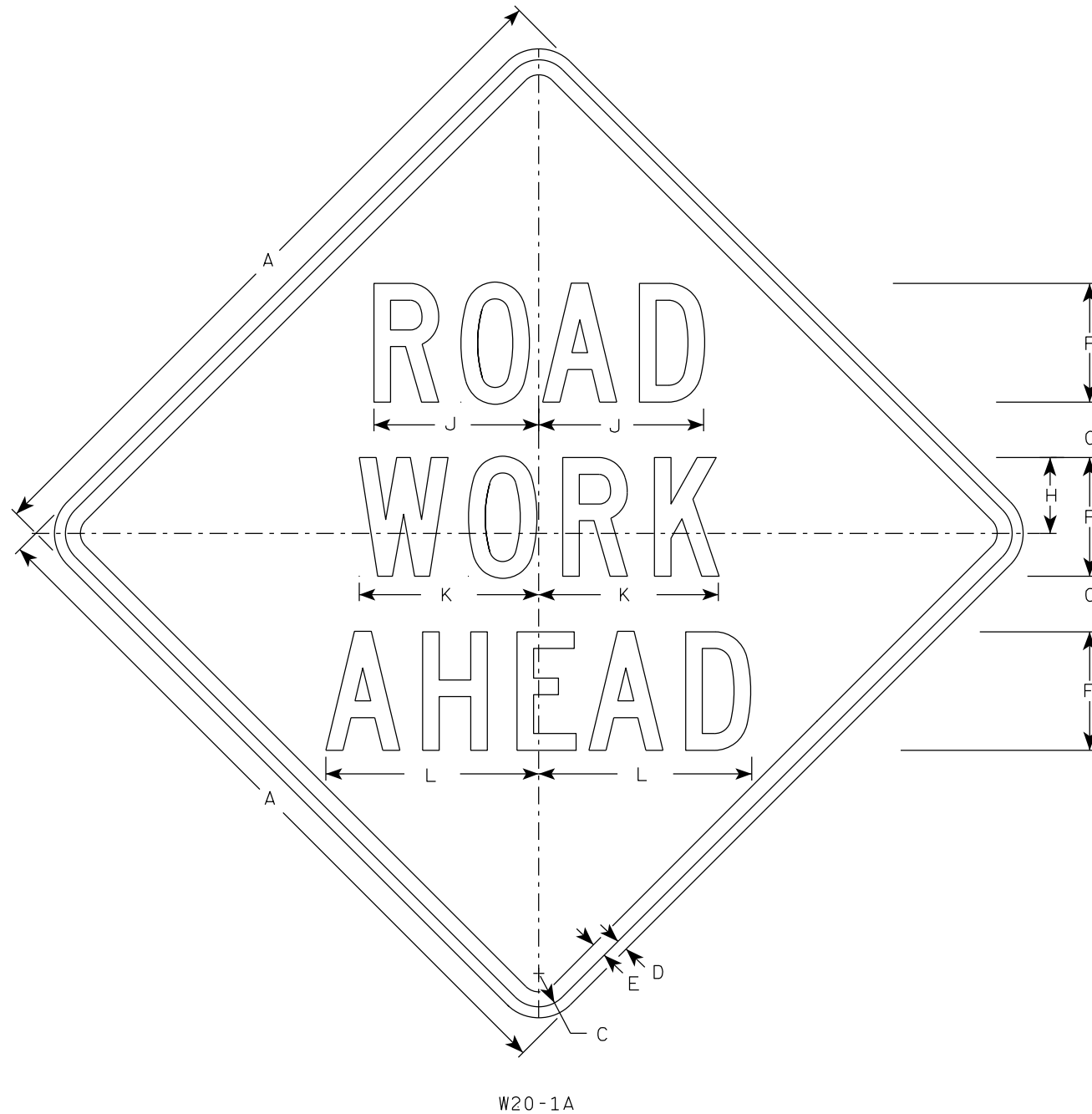

SIZE	A	B	C	D	E	F	G	H	I	J	K	L	M	N	O	P	Q	R	S	T	U	V	W	X	Y	Z	Area sq. ft.
1	36		1 5/8	5/8	3/4	5	2 5/8	3 1/4	10 1/8	7	7 5/8	8 7/8	1 1/8	4 1/2	3 1/2	9	3 1/4	2 1/2	2 1/4	5 5/8	9	1 3/8	8	1 3/4	10 3/4	6	9.0
2S	48		2 1/4	3/4	1	8	3 3/4	5 1/8	15 3/8	11 1/8	12 1/8	14 3/8	1 5/8	6 7/8	5 3/8	13 7/8	4 3/8	3 7/8	3	8 5/8	13 3/4	2 1/8	11 7/8	2 3/4	16 3/8	9	16.0
2M	48		2 1/4	3/4	1	8	3 3/4	5 1/8	15 3/8	11 1/8	12 1/8	14 3/8	1 5/8	6 7/8	5 3/8	13 7/8	4 3/8	3 7/8	3	8 5/8	13 3/4	2 1/8	11 7/8	2 3/4	16 3/8	9	16.0
3	48		2 1/4	3/4	1	8	3 3/4	5 1/8	15 3/8	11 1/8	12 1/8	14 3/8	1 5/8	6 7/8	5 3/8	13 7/8	4 3/8	3 7/8	3	8 5/8	13 3/4	2 1/8	11 7/8	2 3/4	16 3/8	9	16.0
4	48		2 1/4	3/4	1	8	3 3/4	5 1/8	15 3/8	11 1/8	12 1/8	14 3/8	1 5/8	6 7/8	5 3/8	13 7/8	4 3/8	3 7/8	3	8 5/8	13 3/4	2 1/8	11 7/8	2 3/4	16 3/8	9	16.0
5	48		2 1/4	3/4	1	8	3 3/4	5 1/8	15 3/8	11 1/8	12 1/8	14 3/8	1 5/8	6 7/8	5 3/8	13 7/8	4 3/8	3 7/8	3	8 5/8	13 3/4	2 1/8	11 7/8	2 3/4	16 3/8	9	16.0

STANDARD SIGN
W20-1A, B, C, D, E, F, G & H

WISCONSIN DEPT OF TRANSPORTATION

APPROVED *Matthew R. Rauch*
For State Traffic Engineer

DATE 3/25/2020 PLATE NO. W20-1.11

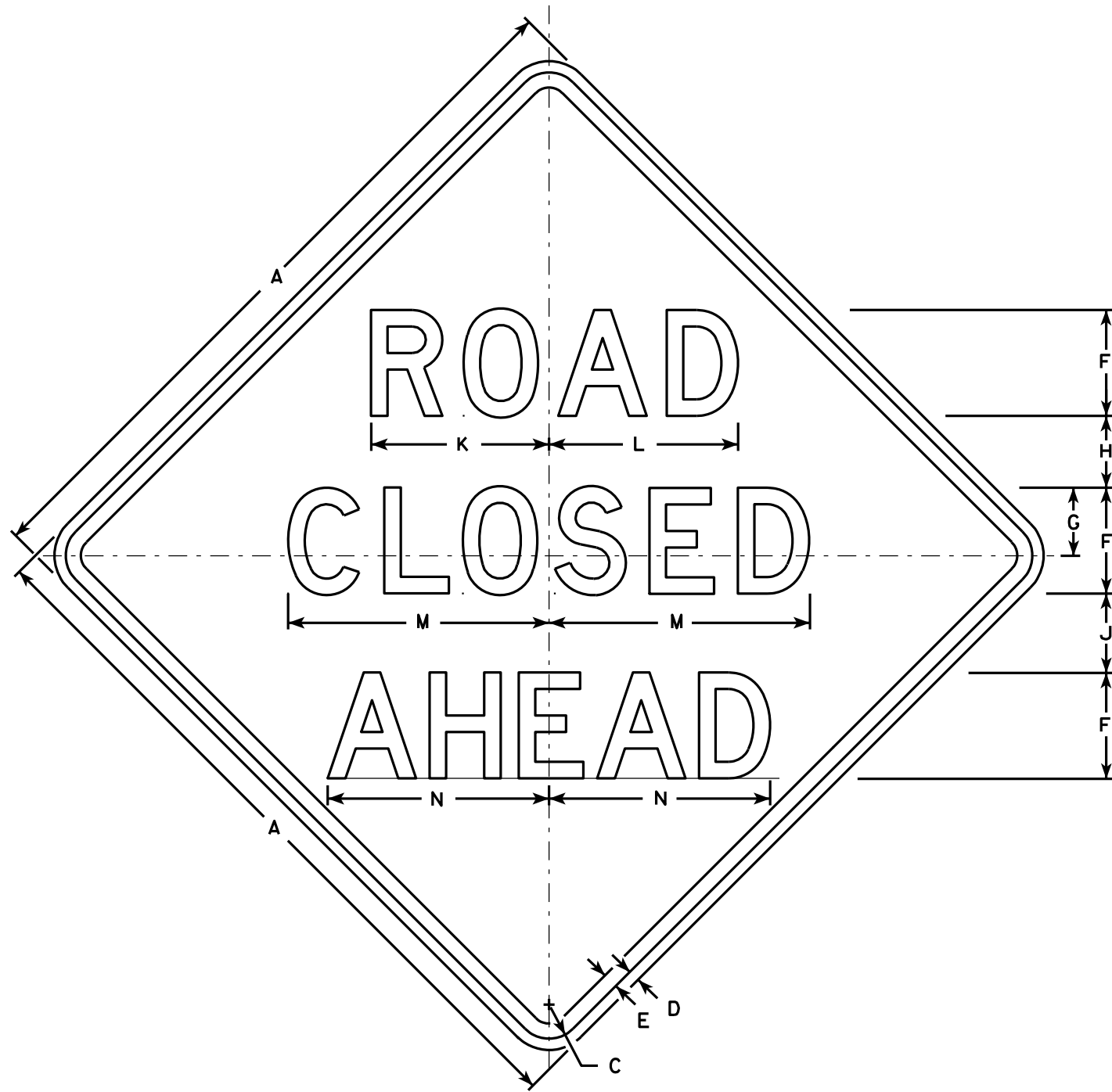

W20-3A

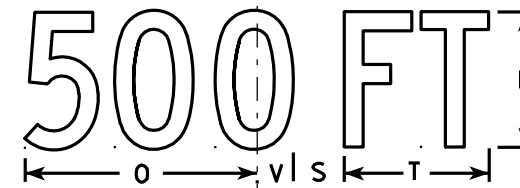

W20-3D

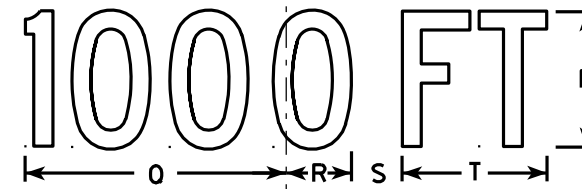

W20-3C

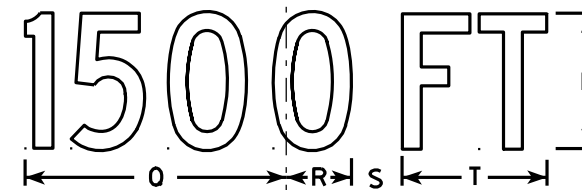

W20-3B

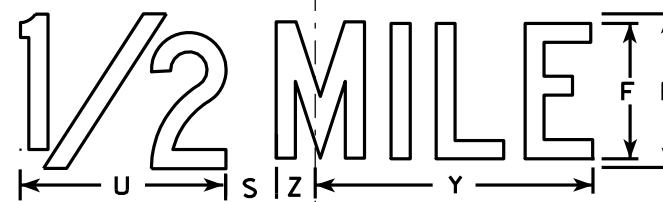

W20-3G



W20-3F

NOTES

1. Sign is Type II - Type F Reflective - reference WIS DOT Standard Specification for HIGHWAY and STRUCTURE CONSTRUCTION latest edition.
2. Color:
Background - Orange
Message - Black
3. Message Series - see note 5
4. Corners may be square or rounded when base material is plywood but borders shall be rounded as shown. When base material is metal, the corners and borders shall be rounded.
5. Lines 1 and 2 are Series D.
Line 3 is Series D for AHEAD and Series C for all other distances.

7

7

SIZE	A	B	C	D	E	F	G	H	I	J	K	L	M	N	O	P	Q	R	S	T	U	V	W	X	Y	Z	Area sq. ft.
1	36		1 5/8	5/8	3/4	5	3 3/8	3 1/2	1 1/8	4	8 3/8	8 7/8	12 1/2	11	9	6	10 1/8	2 1/2	1 7/8	5 5/8	8	1 3/8	4 1/2	3 1/2	10 3/4	1 3/4	9.0
2S	48		2 1/4	3/4	1	7	4 1/2	4 3/4	1 1/2	5 1/4	11 3/4	12 1/2	17 1/4	14 5/8	12	8	13 1/2	3 3/8	2 5/8	7 1/2	10 5/8	1 7/8	6	4 5/8	14 3/8	2 3/8	16.0
2M	48		2 1/4	3/4	1	7	4 1/2	4 3/4	1 1/2	5 1/4	11 3/4	12 1/2	17 1/4	14 5/8	12	8	13 1/2	3 3/8	2 5/8	7 1/2	10 5/8	1 7/8	6	4 5/8	14 3/8	2 3/8	16.0
3	48		2 1/4	3/4	1	7	4 1/2	4 3/4	1 1/2	5 1/4	11 3/4	12 1/2	17 1/4	14 5/8	12	8	13 1/2	3 3/8	2 5/8	7 1/2	10 5/8	1 7/8	6	4 5/8	14 3/8	2 3/8	16.0
4	48		2 1/4	3/4	1	7	4 1/2	4 3/4	1 1/2	5 1/4	11 3/4	12 1/2	17 1/4	14 5/8	12	8	13 1/2	3 3/8	2 5/8	7 1/2	10 5/8	1 7/8	6	4 5/8	14 3/8	2 3/8	16.0
5	48		2 1/4	3/4	1	7	4 1/2	4 3/4	1 1/2	5 1/4	11 3/4	12 1/2	17 1/4	14 5/8	12	8	13 1/2	3 3/8	2 5/8	7 1/2	10 5/8	1 7/8	6	4 5/8	14 3/8	2 3/8	16.0

STANDARD SIGN
W20-3A, B, C, D, F & G

WISCONSIN DEPT OF TRANSPORTATION

APPROVED *Matthew R. Rauch*
For State Traffic Engineer

DATE 3/18/11 PLATE NO. W20-3.7

EARTHWORK DATA															
STATION	REAL STATION	DISTANCE	AREA (SF)				INCREMENTAL VOL (CY) (UNADJUSTED)				CUMULATIVE VOL (CY)				
			SALVAGED/UNUSABLE PAVEMENT MATERIAL				SALVAGED/UNUSABLE PAVEMENT MATERIAL				CUT	EXPANDED FILL	EBS BACKFILL	REDUCED EBS IN FILL	MASS ORDINATE
			CUT	E PAVEMENT	FILL	EBS	CUT	E PAVEMENT	FILL	EBS					
			NOTE 1	NOTE 2	NOTE 3	NOTE 1	NOTE 2	NOTE 3	NOTE 1	NOTE 2					
101+55	10155	0	30.15	11.00	0.00	0.00	0	0	0	0	0	0	0	0	
102+00	10200	45	43.78	11.00	2.80	0.00	62	18	2	0	62	3	0	40	
103+00	10300	100	47.78	11.00	1.06	0.00	170	41	7	0	231	12	0	160	
104+00	10400	100	36.96	11.00	1.55	0.00	157	41	5	0	388	18	0	270	
105+00	10500	100	21.37	11.00	0.55	0.00	108	41	4	0	496	23	0	333	
105+40	10540	40	16.70	11.00	8.88	0.00	28	16	7	0	524	31	0	336	
106+00	10600	60	25.58	11.00	6.81	248.24	47	24	17	276	571	53	359	623	
107+00	10700	100	19.62	11.00	21.07	246.75	84	41	52	917	655	118	1,550	1,508	
107+06	10706	6	20.29	11.00	13.07	246.19	4	2	4	55	659	123	1,621	1,560	
107+31	10731	25	23.20	11.00	12.32	243.81	20	10	12	227	680	137	1,916	1,782	
107+56	10756	25	23.99	11.00	10.61	243.89	22	10	11	226	701	151	2,210	2,006	
108+00	10800	44	26.49	11.00	6.88	243.50	41	18	14	397	743	168	2,726	2,408	
109+00	10900	100	30.40	11.00	3.94	239.89	105	41	20	895	848	193	3,890	3,343	
109+23	10923	23	30.84	11.00	12.50	244.08	26	9	7	206	874	202	4,158	3,557	
109+48	10948	25	35.67	11.00	13.19	248.63	31	10	12	228	905	217	4,454	3,791	
109+73	10973	25	34.71	11.00	0.00	250.33	33	10	6	231	937	225	4,755	4,037	
110+00	11000	27	30.33	11.00	0.00	252.75	33	11	0	252	970	225	5,082	4,310	
111+00	11100	100	25.50	11.00	0.00	344.93	103	41	0	1107	1,073	225	6,521	5,479	
112+00	11200	100	35.01	11.00	1.49	288.84	112	41	3	1174	1,185	228	8,046	6,721	
113+00	11300	100	60.10	11.00	0.00	268.13	176	41	3	1031	1,361	232	9,387	7,884	
114+00	11400	100	57.39	11.00	0.00	271.69	218	41	0	1000	1,579	232	10,687	9,061	
115+00	11500	100	50.34	11.00	1.59	279.39	200	41	3	1021	1,779	235	12,013	10,236	
115+70	11570	70	53.40	11.00	0.00	273.11	134	29	2	716	1,913	238	12,944	11,056	
115+95	11595	25	55.22	11.00	1.78	262.18	50	10	1	248	1,963	239	13,267	11,343	
116+00	11600	5	55.85	11.00	1.90	260.26	10	2	0	48	1,974	239	13,329	11,399	
116+20	11620	20	62.13	11.00	1.37	248.40	44	8	1	188	2,017	241	13,574	11,621	
117+00	11700	80	60.35	11.00	0.10	249.02	181	33	2	737	2,199	243	14,532	12,505	
118+00	11800	100	50.45	11.00	2.27	253.39	205	41	4	930	2,404	249	15,742	13,594	
118+60	11860	60	32.06	11.00	1.77	0.00	92	24	4	282	2,496	255	16,108	13,937	
119+00	11900	40	23.34	11.00	4.66	0.00	41	16	5	0	2,537	261	16,108	13,956	
120+00	12000	100	11.36	11.00	7.62	0.00	64	41	23	0	2,601	289	16,108	13,951	
121+00	12100	100	21.50	11.00	6.07	0.00	61	41	25	0	2,662	321	16,108	13,939	
122+00	12200	100	41.87	11.00	0.63	0.00	117	41	12	0	2,779	336	16,108	14,000	
123+00	12300	100	20.69	11.00	3.94	0.00	116	41	8	0	2,895	347	16,108	14,065	
123+60	12360	60	27.12	11.00	2.52	0.00	53	24	7	0	2,948	356	16,108	14,085	
124+00	12400	40	25.02	11.00	3.28	151.88	39	16	4	113	2,987	361	16,254	14,214	
124+50	12450	50	23.14	11.00	3.36	441.04	45	20	6	549	3,031	369	16,968	14,780	
125+00	12500	50	15.79	11.00	1.73	459.19	36	20	5	834	3,067	375	18,051	15,623	
126+00	12600	100	12.69	11.00	6.34	449.59	53	41	15	1683	3,120	393	20,239	17,299	
127+00	12700	100	40.64	11.00	2.03	460.93	99	41	16	1686	3,219	413	22,431	19,024	
127+50	12750	50	33.94	11.00	2.33	427.77	69	20	4	823	3,288	418	23,501	19,891	
128+00	12800	50	43.90	11.00	0.11	199.33	72	20	2	581	3,360	421	24,256	20,520	
128+40	12840	40	33.27	11.00	1.68	0.00	57	16	1	148	3,417	422	24,448	20,707	

CONTINUED ON NEXT PAGE

NOTES:	
1 - CUT	CUT INCLUDES SALVAGED/UNUSABLE PAVEMENT MATERIAL
2 - SALVAGED/UNUSABLE PAVEMENT MATERIAL	THIS DOES NOT SHOW UP IN CROSS SECTIONS
3 - FILL	DOES NOT INCLUDE UNUSABLE PAVEMENT EXC VOLUME
4 - EXPANDED EBS	WILL BE BACKFILLED WITH GRANULAR BACKFILL (OR CUT, OR BORROW)
5 - REDUCED EBS IN FILL	REDUCED EBS EXCAVATION THAT CAN BE USED IN FILL
6 - MASS ORDINATE	IF MARSH AND EBS TO BE BACKFILLED WITH GRANULAR: [CUT - SALVAGED PAVT - ((FILL - REDUCED MARSH IN FILL - REDUCED EBS IN FILL) * FILL FACTOR)]

EARTHWORK DATA																	
STATION	REAL STATION	DISTANCE	AREA (SF)				INCREMENTAL VOL (CY) (UNADJUSTED)				CUMULATIVE VOL (CY)						
			CUT	SALVAGED/UNUSABLE PAVEMENT MATERIAL		FILL	EBS	CUT	SALVAGED/UNUSABLE PAVEMENT MATERIAL		FILL	EBS	CUT	EXPANDED FILL	EXPANDED EBS BACKFILL	REDUCED EBS IN FILL	MASS ORDINATE
				NOTE 1	NOTE 2				NOTE 3	NOTE 1							
129+00	12900	60	28.44	11.00	2.62	0.00	69	24	5	0	3,486	428	24,448	15,045	20,745		
130+00	13000	100	7.91	7.91	3.67	0.00	67	35	12	0	3,553	443	24,448	15,045	20,763		
131+00	13100	100	7.45	7.45	5.78	0.00	28	28	18	0	3,581	465	24,448	15,045	20,741		
132+00	13200	100	7.33	7.33	5.86	0.00	27	27	22	0	3,609	492	24,448	15,045	20,714		
133+00	13300	100	13.86	11.00	1.77	0.00	39	34	14	0	3,648	509	24,448	15,045	20,702		
134+00	13400	100	39.45	11.00	0.00	0.00	99	41	3	0	3,747	513	24,448	15,045	20,756		
135+00	13500	100	29.38	11.00	0.33	0.00	127	41	1	0	3,874	514	24,448	15,045	20,841		
136+00	13600	100	58.70	11.00	0.28	0.00	163	41	1	0	4,037	516	24,448	15,045	20,962		
136+40	13640	40	65.30	11.00	2.99	0.00	92	16	2	0	4,129	519	24,448	15,045	21,035		
137+00	13700	60	86.68	11.00	3.47	230.15	169	24	7	256	4,298	528	24,780	15,249	21,426		
137+13	13713.12	13	82.33	11.00	2.14	229.38	41	5	1	112	4,339	529	24,925	15,339	21,572		
138+00	13800	87	58.93	11.00	0.00	238.17	227	35	3	752	4,566	534	25,903	15,940	22,512		
139+00	13900	100	39.25	11.00	1.28	248.28	182	41	2	901	4,748	536	27,074	16,661	23,551		
139+60	13960	60	33.68	11.00	1.09	0.00	81	24	3	276	4,829	540	27,433	16,882	23,880		
140+00	14000	40	32.98	11.00	1.68	0.00	49	16	2	0	4,879	542	27,433	16,882	23,910		
141+00	14100	100	31.39	11.00	1.92	0.00	119	41	7	0	4,998	551	27,433	16,882	23,980		
142+00	14200	100	20.13	11.00	1.74	0.00	95	41	7	0	5,093	559	27,433	16,882	24,027		
142+46	14245.77	46	11.94	11.00	1.58	0.00	27	19	3	0	5,120	563	27,433	16,882	24,032		
142+71	14270.77	25	8.96	11.00	2.80	0.00	10	10	2	0	5,130	565	27,433	16,882	24,029		
142+96	14295.77	25	9.29	11.00	7.56	0.00	8	10	5	0	5,139	571	27,433	16,882	24,021		
143+00	14300	4	8.92	11.00	6.67	0.00	1	2	1	0	5,140	573	27,433	16,882	24,019		
144+00	14400	100	8.25	11.00	2.93	0.00	32	41	18	0	5,172	595	27,433	16,882	23,988		
145+00	14500	100	10.25	11.00	1.16	0.00	34	41	8	0	5,206	604	27,433	16,882	23,972		
146+00	14600	100	32.59	11.00	1.96	0.00	79	41	6	0	5,285	612	27,433	16,882	24,003		
146+04	14604	4	33.78	11.00	1.86	0.00	5	2	0	0	5,290	612	27,433	16,882	24,006		
							5290	1774	489	21102							

NOTES:	
1 - CUT	CUT INCLUDES SALVAGED/UNUSABLE PAVEMENT MATERIAL
2 - SALVAGED/UNUSABLE PAVEMENT MATERIAL	THIS DOES NOT SHOW UP IN CROSS SECTIONS
3 - FILL	DOES NOT INCLUDE UNUSABLE PAVEMENT EXC VOLUME
4 - EXPANDED EBS	WILL BE BACKFILLED WITH GRANULAR BACKFILL (OR CUT, OR BORROW)
5 - REDUCED EBS IN FILL	REDUCED EBS EXCAVATION THAT CAN BE USED IN FILL
6 - MASS ORDINATE	IF MARSH AND EBS TO BE BACKFILLED WITH GRANULAR: [CUT - SALVAGED PAVT - ((FILL - REDUCED MARSH IN FILL - REDUCED EBS IN FILL) * FILL FACTOR)]

9

9

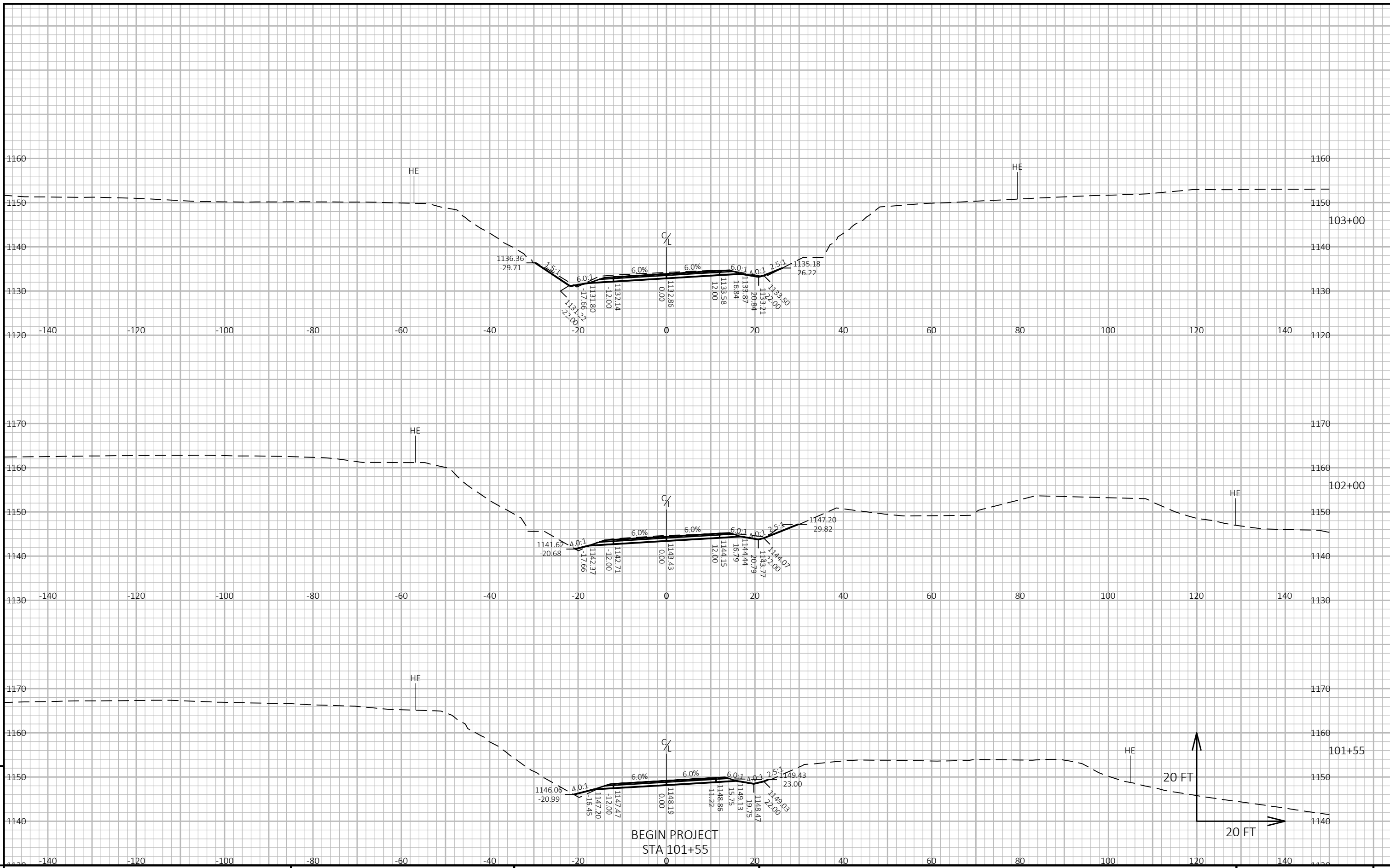

9

9

PROJECT NO: 5305-00-71	HWY: CTH SS	COUNTY: VERNON	CROSS SECTIONS: CTH SS	SHEET	E
------------------------	-------------	----------------	------------------------	-------	---

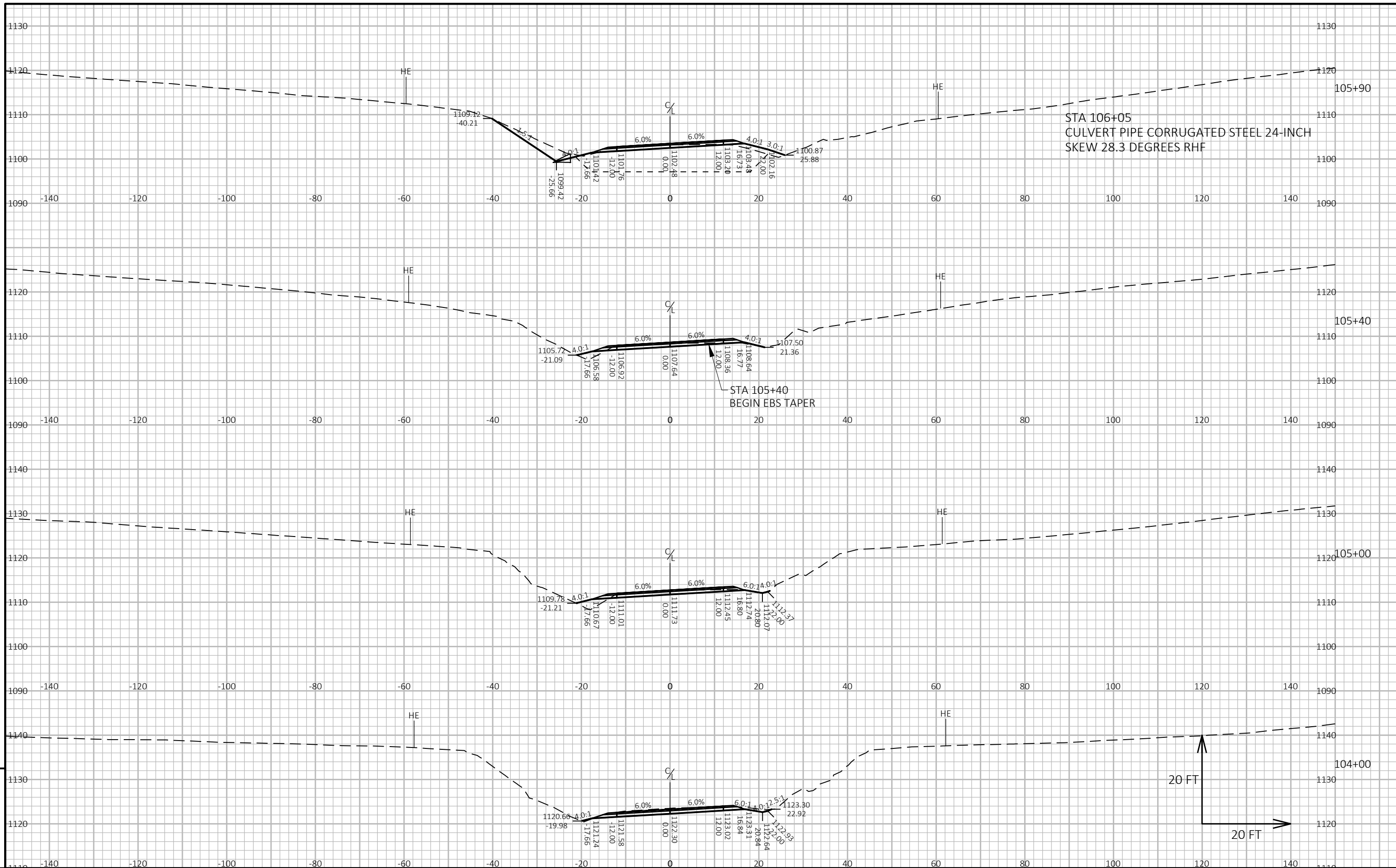

PROJECT NO: 5305-00-71

HWY: CTH SS

COUNTY: VERNON

CROSS SECTIONS: CTH SS

SHEET

E

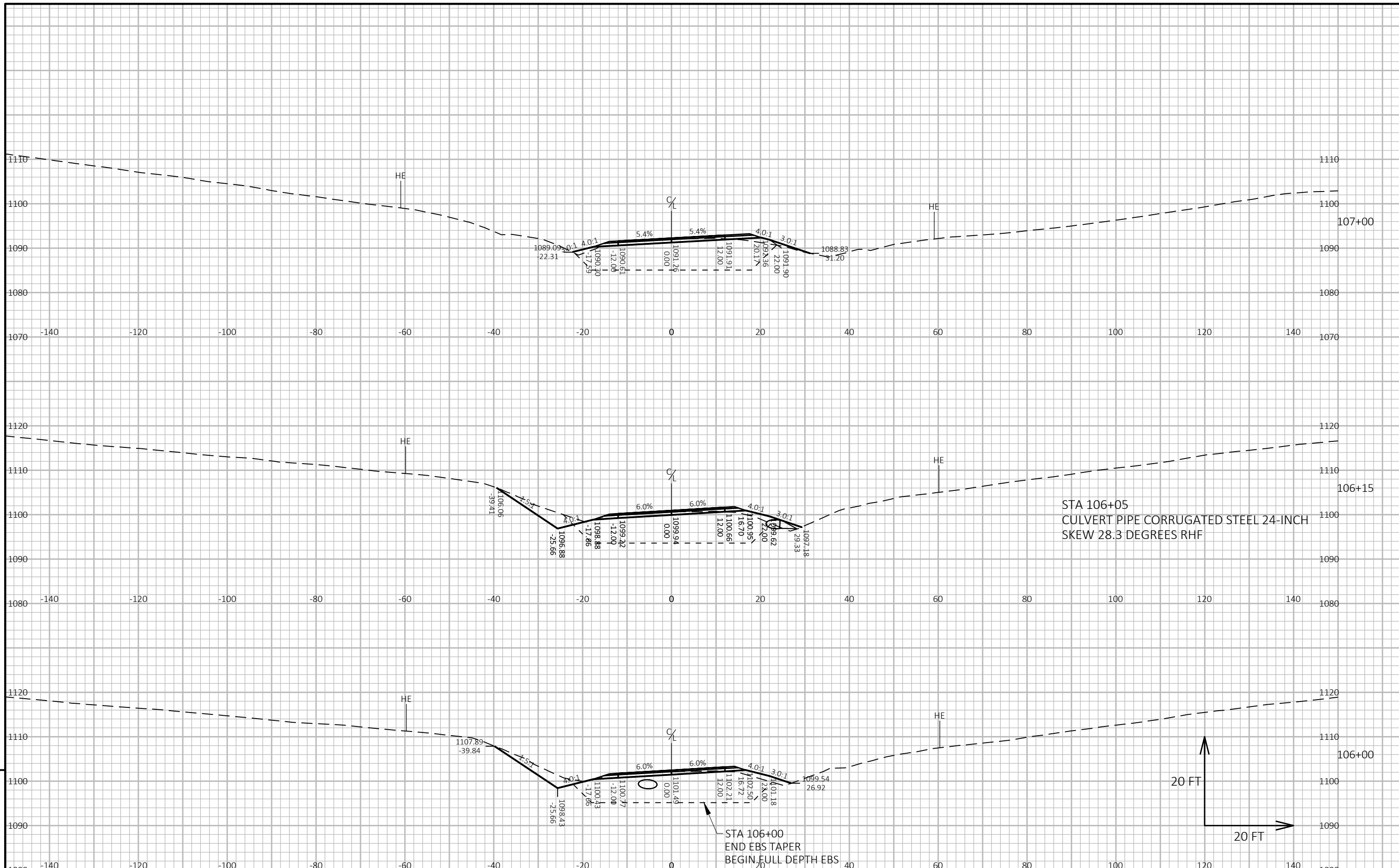

9

9

PROJECT NO: 5305-00-71	HWY: CTH SS	COUNTY: VERNON	CROSS SECTIONS: CTH SS	SHEET	E
------------------------	-------------	----------------	------------------------	-------	---

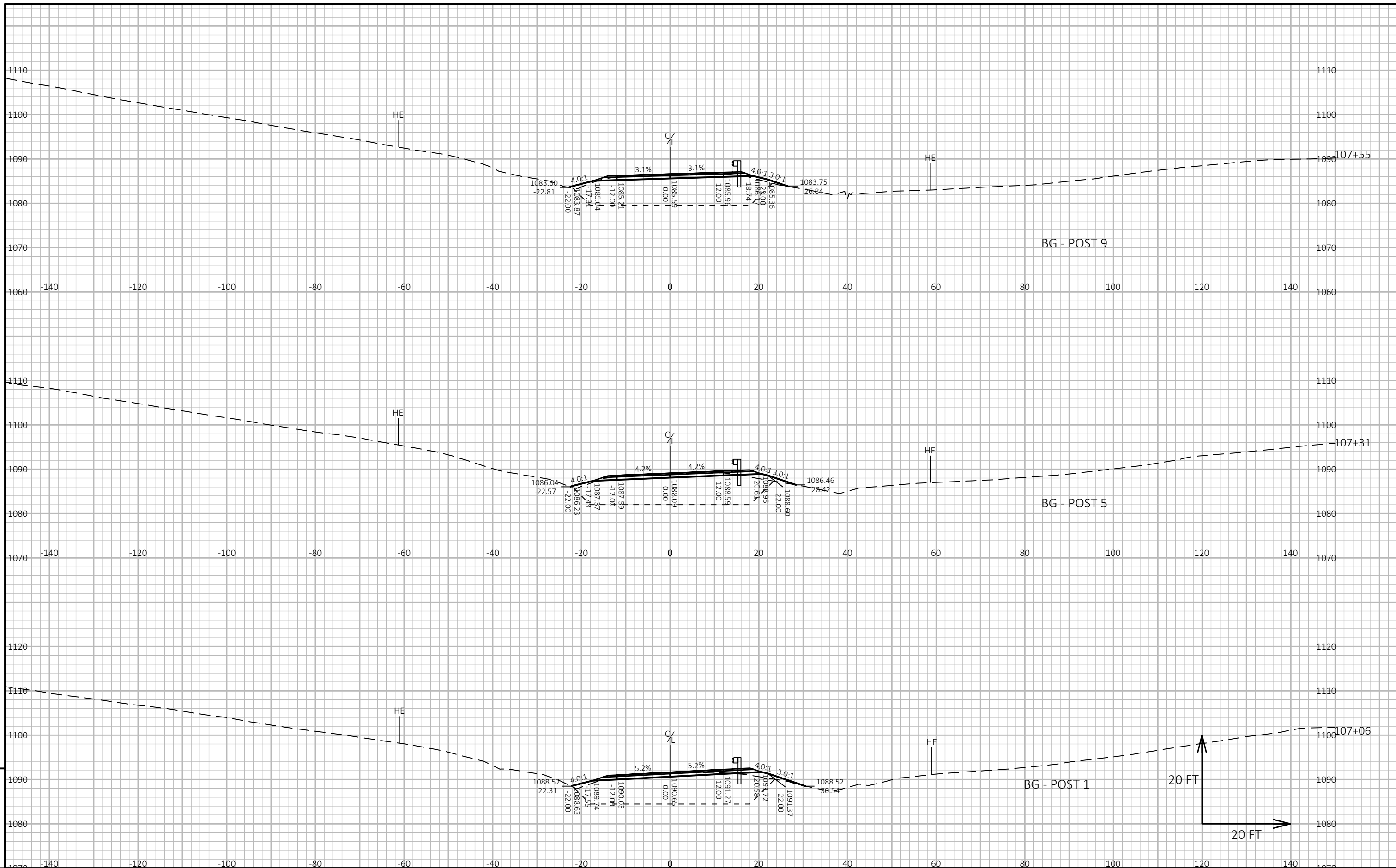

PROJECT NO: 5305-00-71

HWY: CTH SS

COUNTY: VERNON

CROSS SECTIONS: CTH SS

SHEET

E

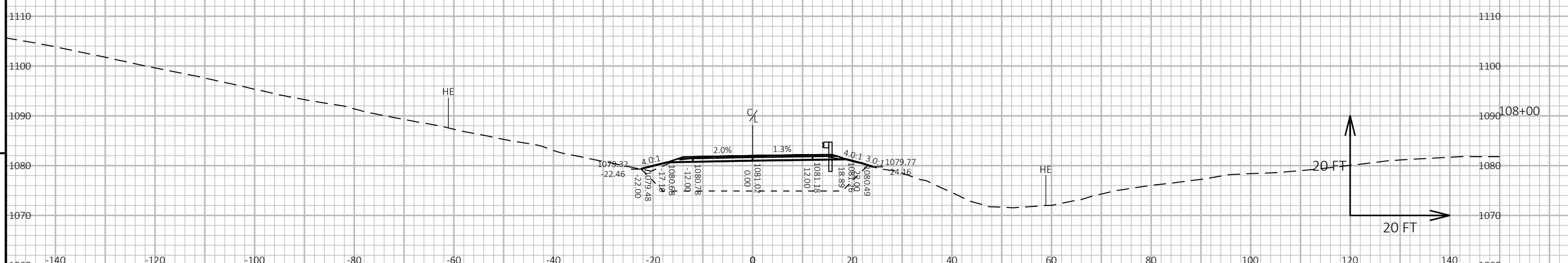
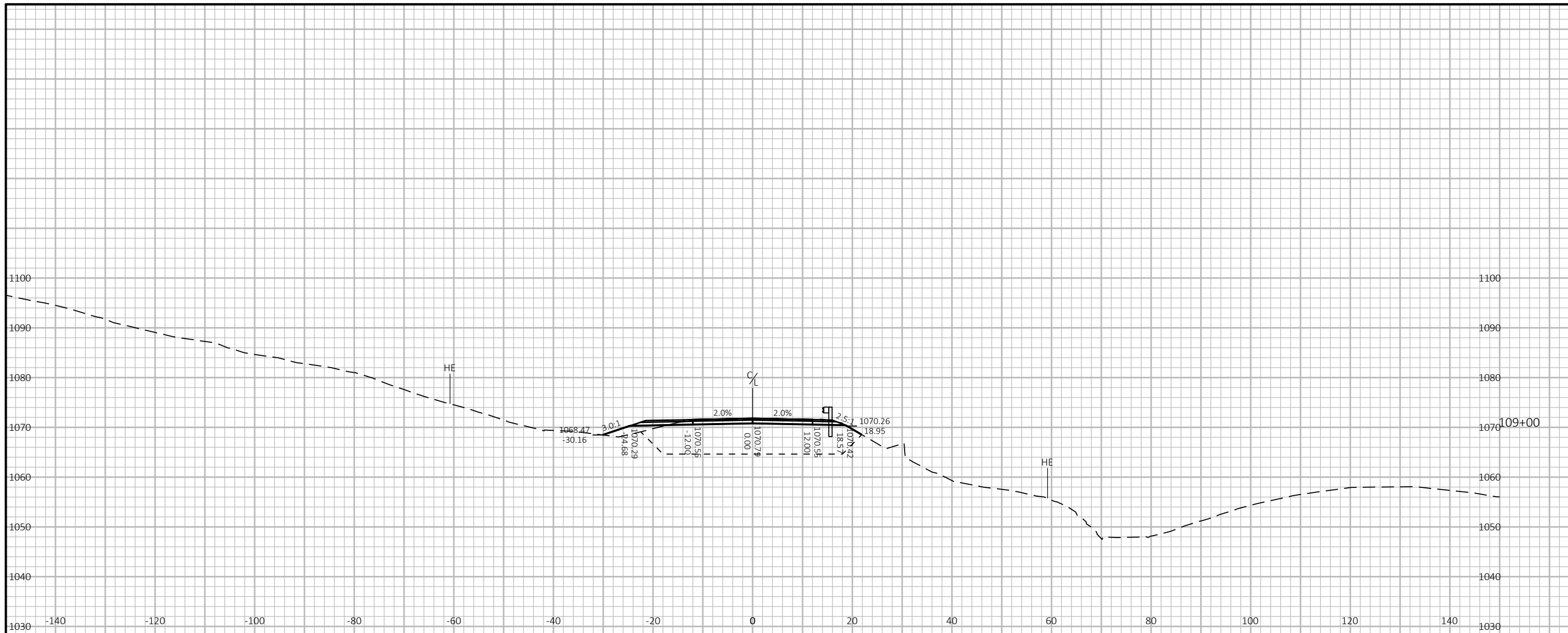

9
PROJECT NO: 5305-00-71
HWY: CTH SS
COUNTY: VERNON
CROSS SECTIONS: CTH SS
SHEET
9

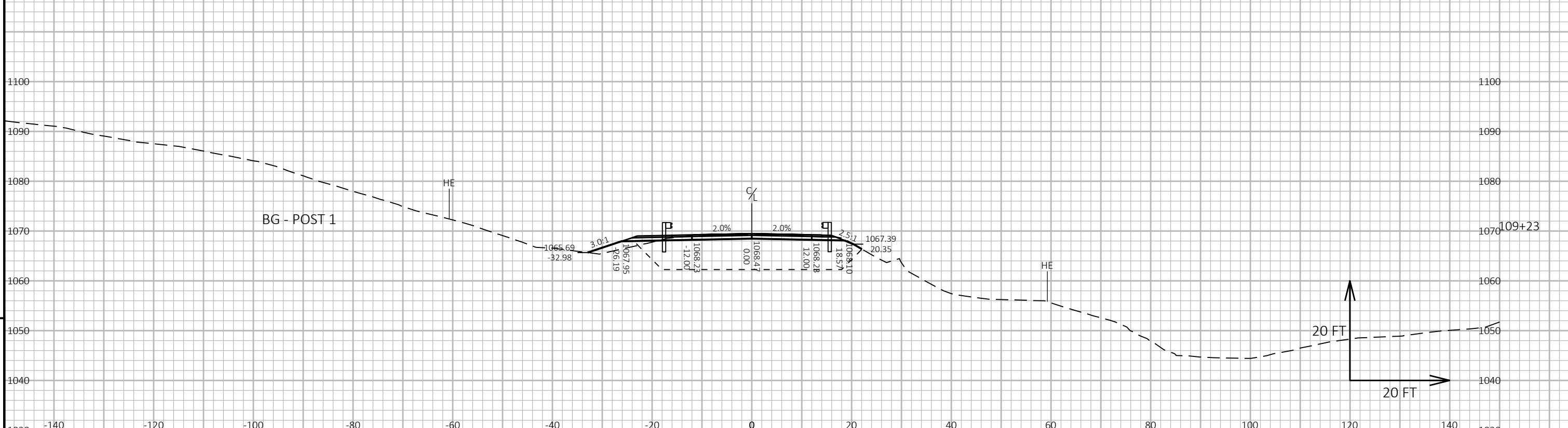
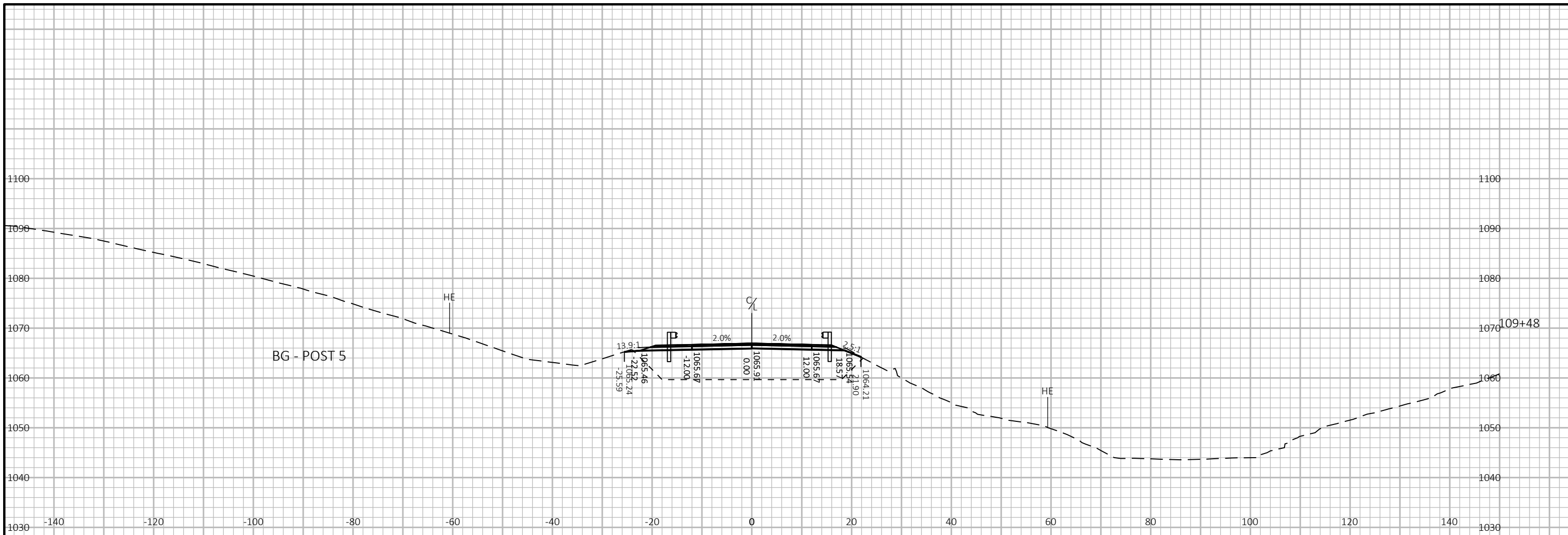

9
20 FT
20 FT
9

PROJECT NO: 5305-00-71 HWY: CTH SS COUNTY: VERNON CROSS SECTIONS: CTH SS SHEET **E**

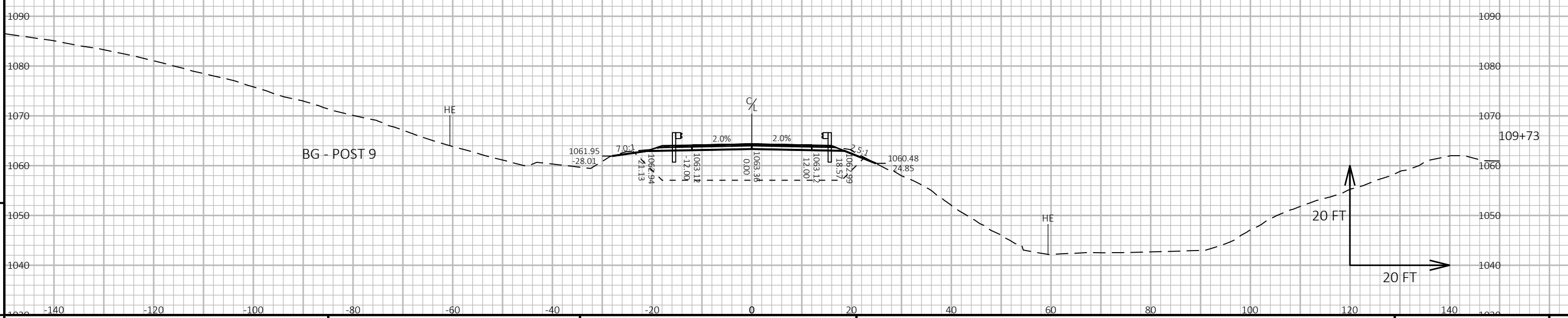
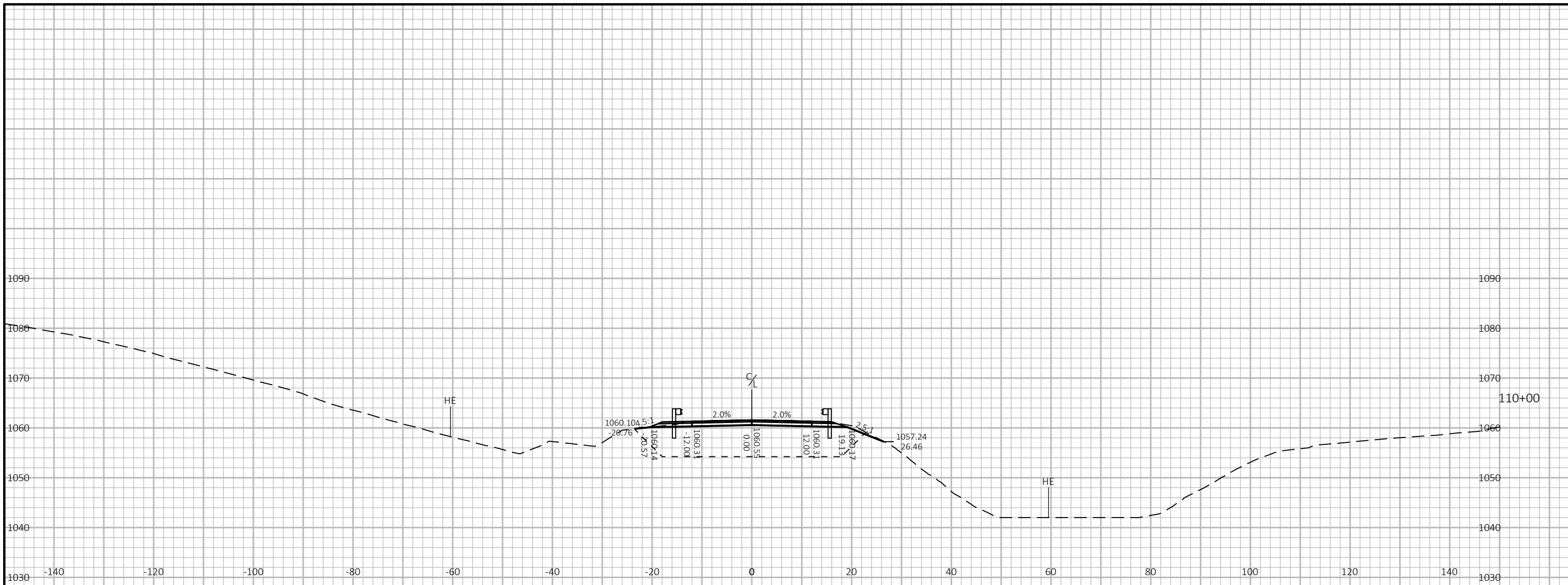

BG - POST 9

20 FT

20 FT

PROJECT NO: 5305-00-71 HWY: CTH SS COUNTY: VERNON CROSS SECTIONS: CTH SS SHEET E

FILE NAME : X:\UZ\VERHD\164916\5-FINAL-DSGN\51-DRAWINGS\40-TRANSHWY\C3D\164916\SHEETSPLAN\SEC 09 B CROSS SECTIONS\090201-XS (CROSS-SECTIONS).DWG PLOT DATE : 9/29/2023 12:02 PM PLOT BY : SAVANNAH STEHN PLOT NAME : PLOT SCALE : 1 IN:20 FT HORZ. / 1 IN:20 FT VERT. WISDOT/CADD SHEET 49

9

9

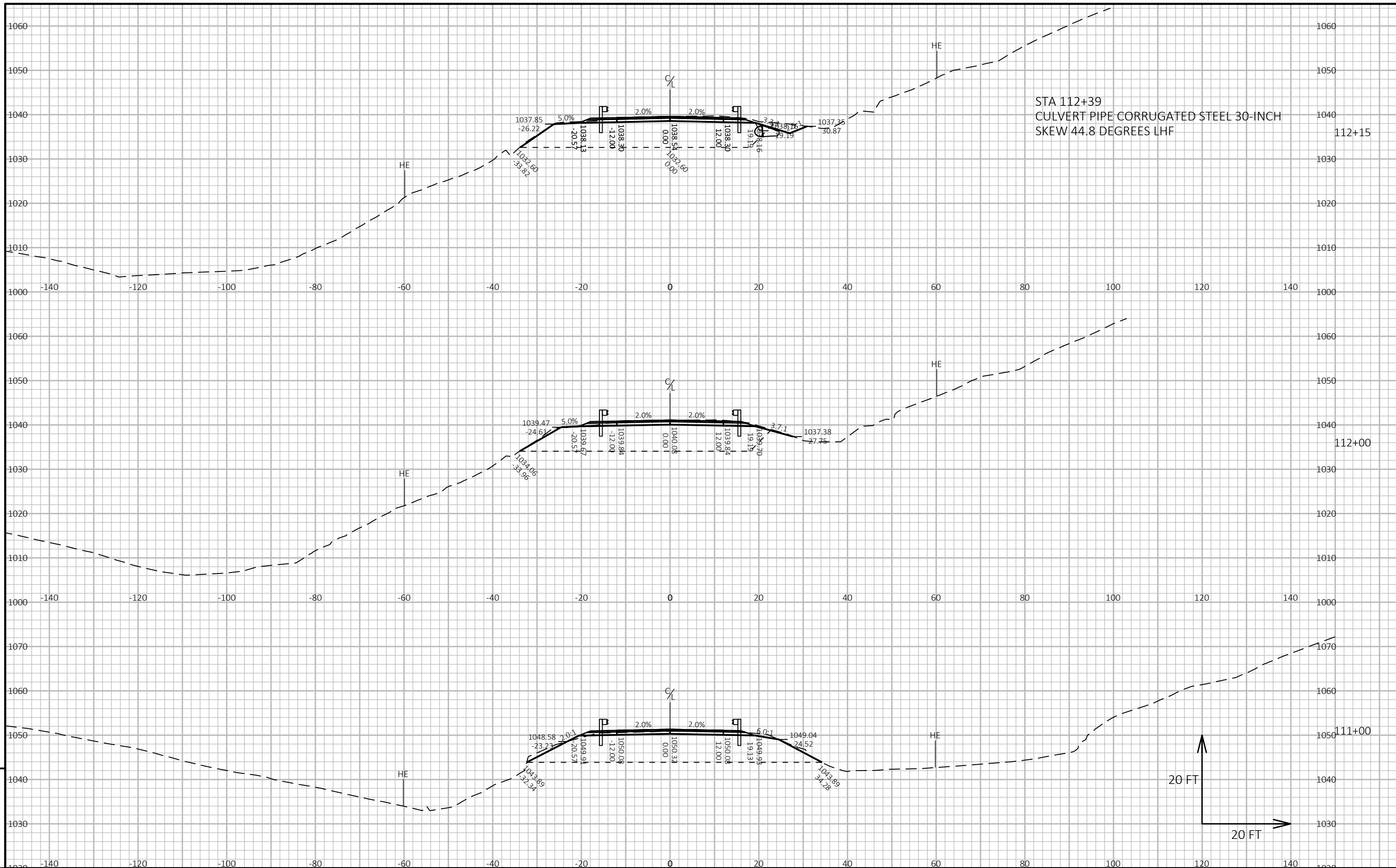

9

9

PROJECT NO: 5305-00-71 HWY: CTH SS COUNTY: VERNON CROSS SECTIONS: CTH SS SHEET E

FILE NAME : X:\UZ\VERHD\164916\5-FINAL-DSGN\51-DRAWINGS\40-TRANSHWY\C3D\164916\SHEETSPLAN\SEC 09 B CROSS SECTIONS\090201-XS (CROSS-SECTIONS).DWG PLOT DATE : 9/28/2023 12:37 PM PLOT BY : SAVANNAH STEHN PLOT NAME : PLOT SCALE : 1 IN:20 FT HORZ. / 1 IN:20 FT VERT. WISDOT/CADD SHEET 49

LAYOUT NAME - 68

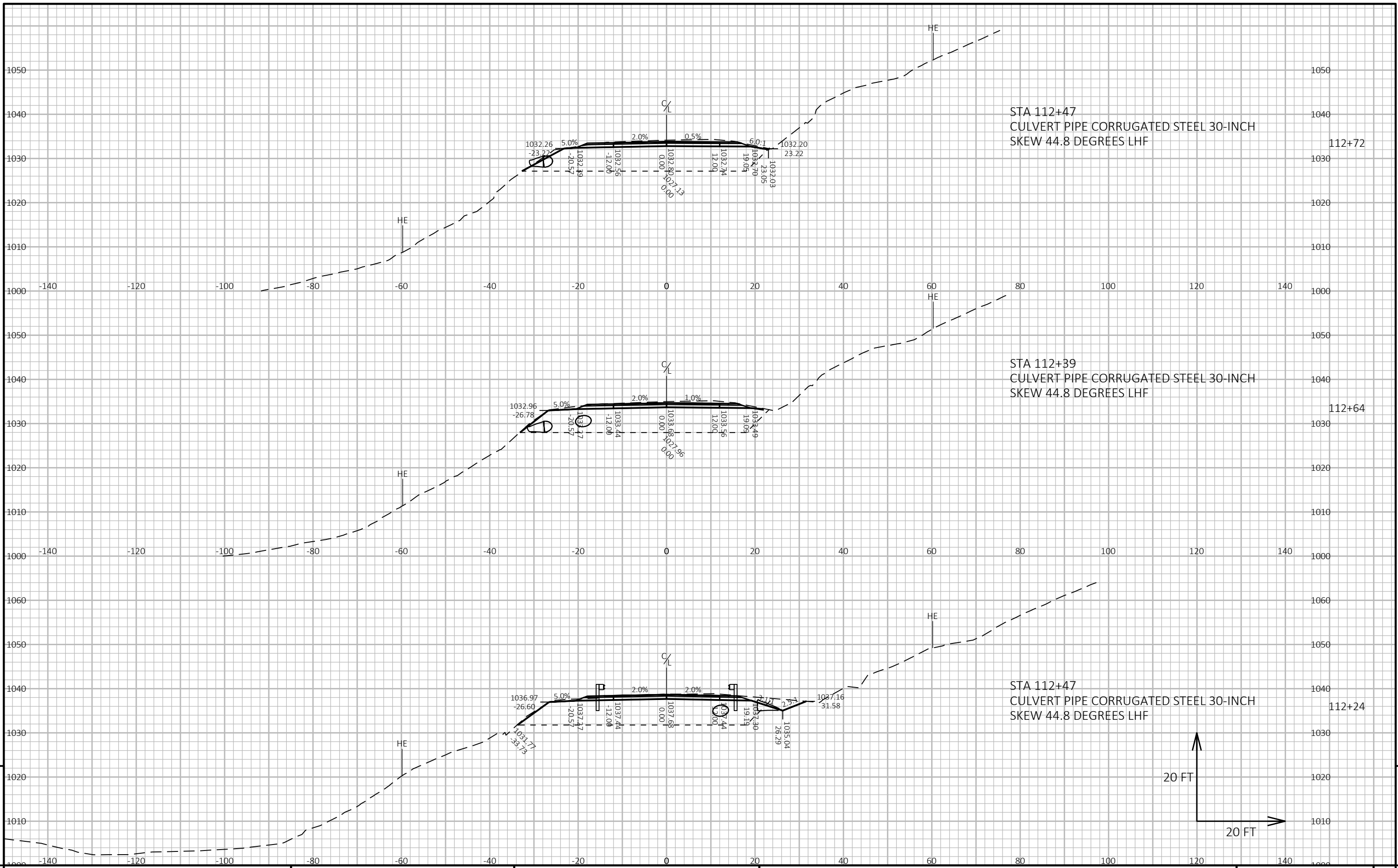

9

9

PROJECT NO: 5305-00-71 HWY: CTH SS COUNTY: VERNON CROSS SECTIONS: CTH SS SHEET E

FILE NAME : X:\UZ\VERHD\164916\5-FINAL-DSGN\51-DRAWINGS\40-TRANSHWY\C3D\164916\SHEETSPLAN\SEC 09 B CROSS SECTIONS\090201-XS (CROSS-SECTIONS).DWG PLOT DATE : 9/28/2023 12:38 PM PLOT BY : SAVANNAH STEHN PLOT NAME : PLOT SCALE : 1 IN:20 FT HORZ. / 1 IN:20 FT VERT. WISDOT/CADDs SHEET 49

LAYOUT NAME - 69

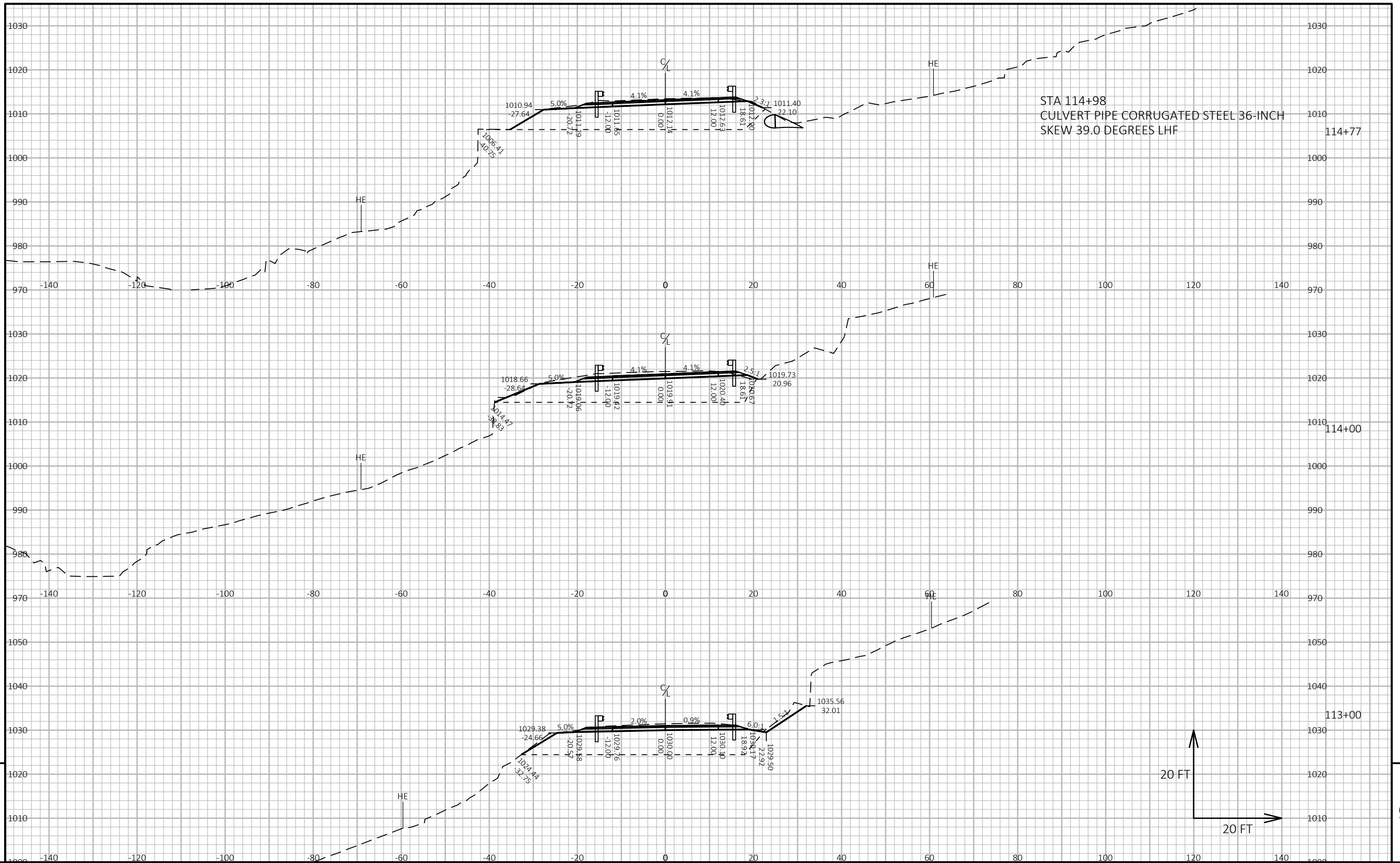

PROJECT NO: 5305-00-71

HWY: CTH SS

COUNTY: VERNON

CROSS SECTIONS: CTH SS

SHEET

E

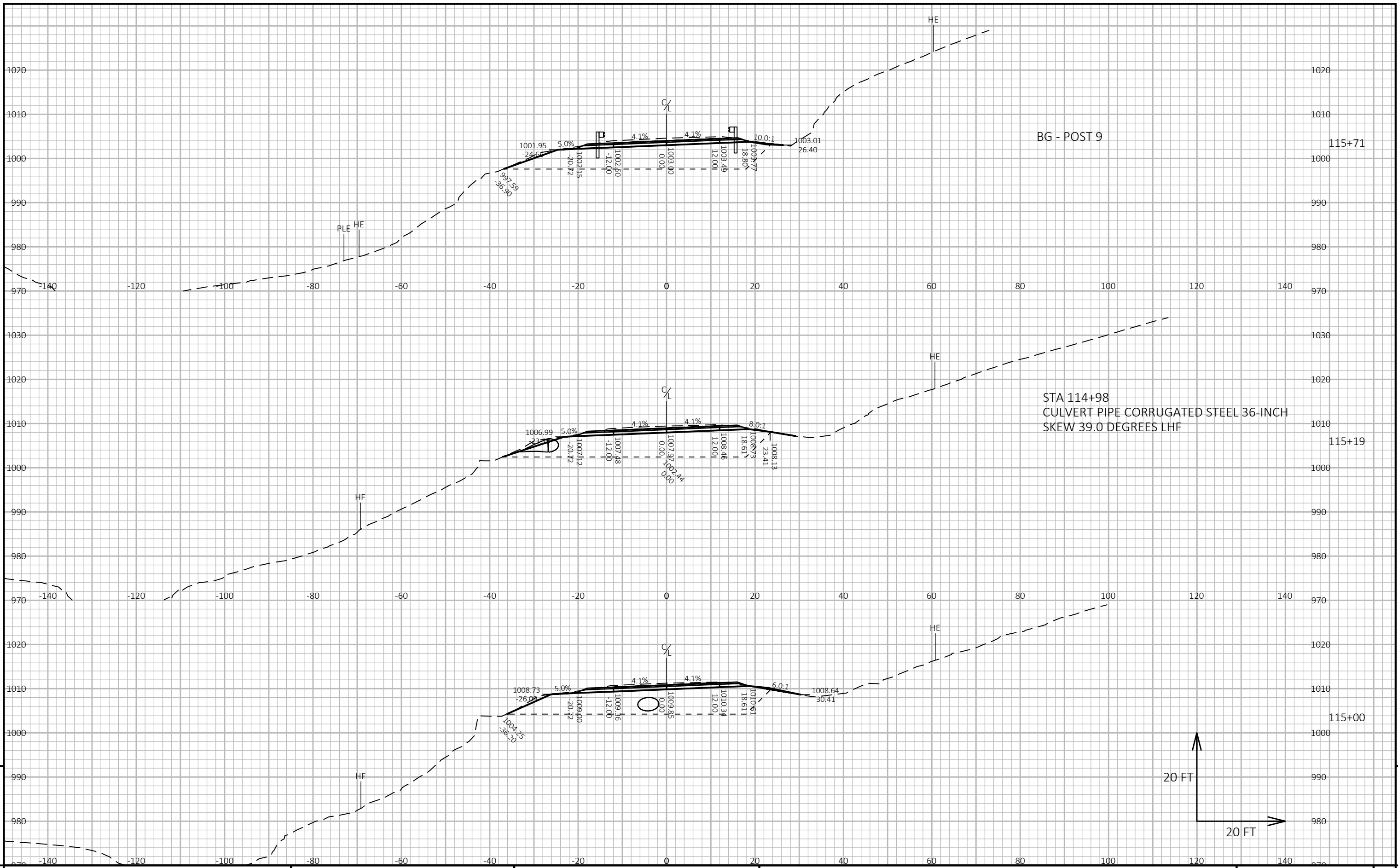

PROJECT NO: 5305-00-71 HWY: CTH SS COUNTY: VERNON CROSS SECTIONS: CTH SS SHEET 9

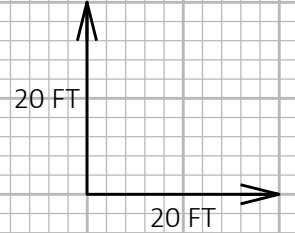
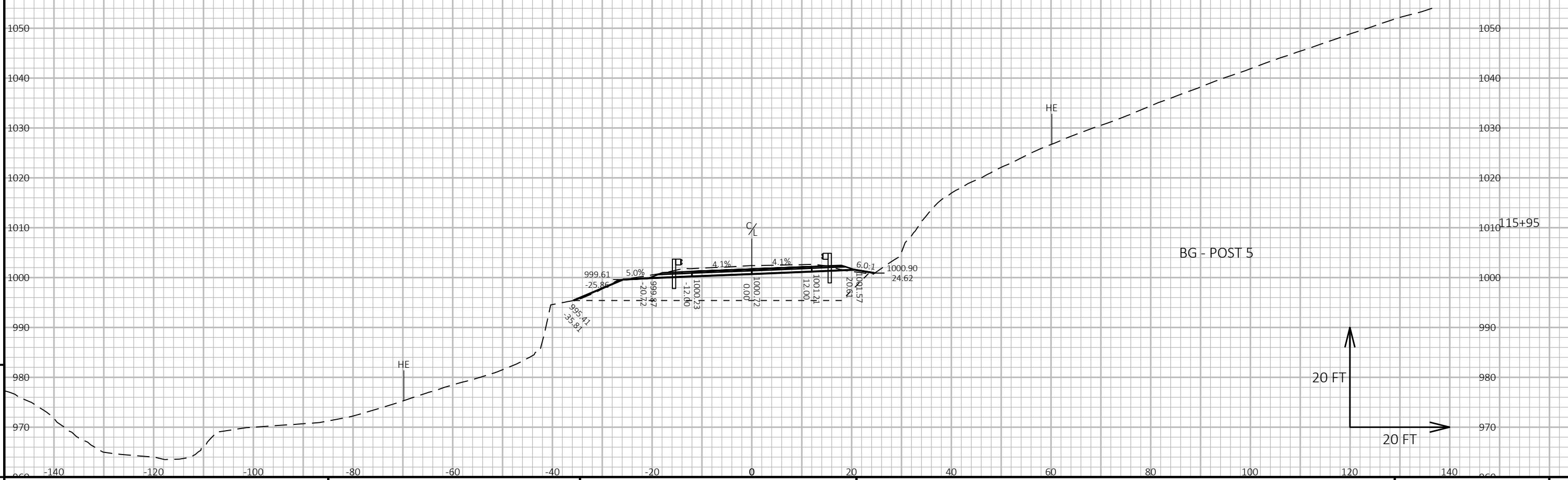
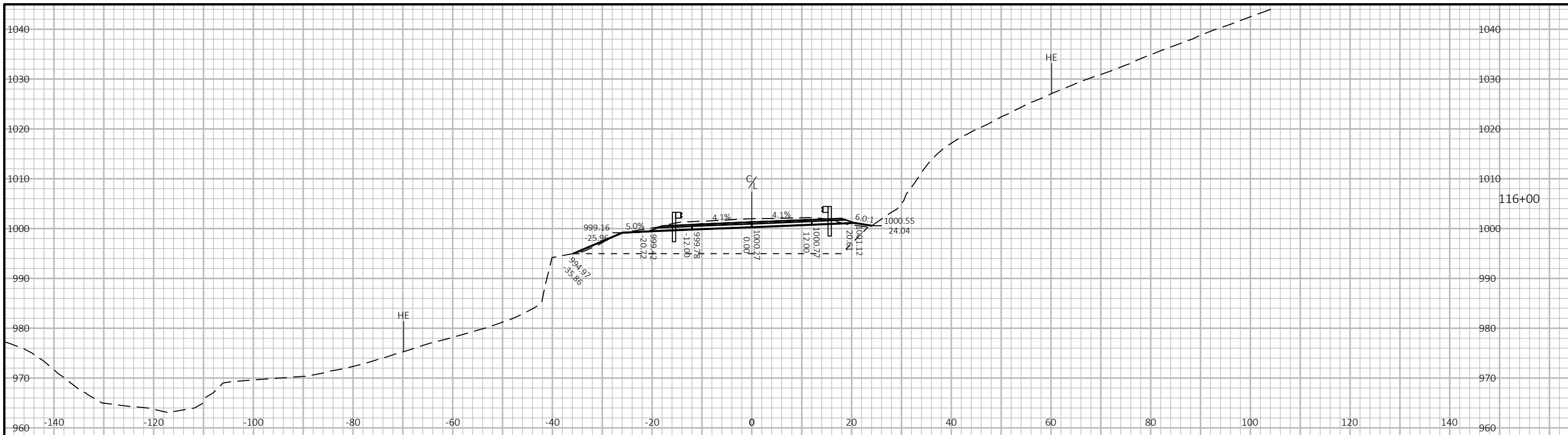

9

PROJECT NO: 5305-00-71 HWY: CTH SS COUNTY: VERNON CROSS SECTIONS: CTH SS SHEET

9

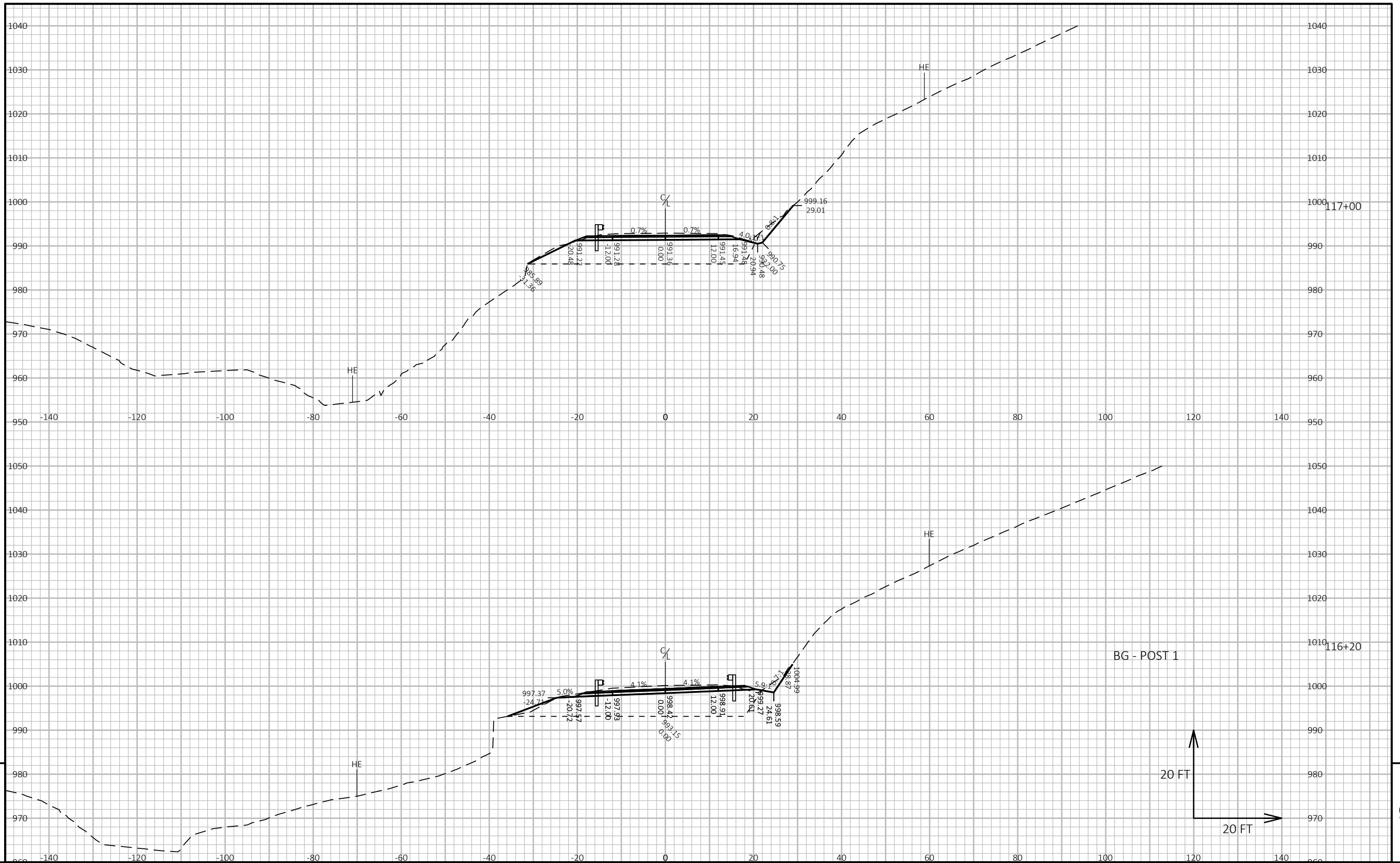

PROJECT NO: 5305-00-71

HWY: CTH SS

COUNTY: VERNON

CROSS SECTIONS: CTH SS

SHEET

E

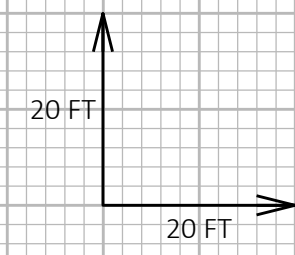
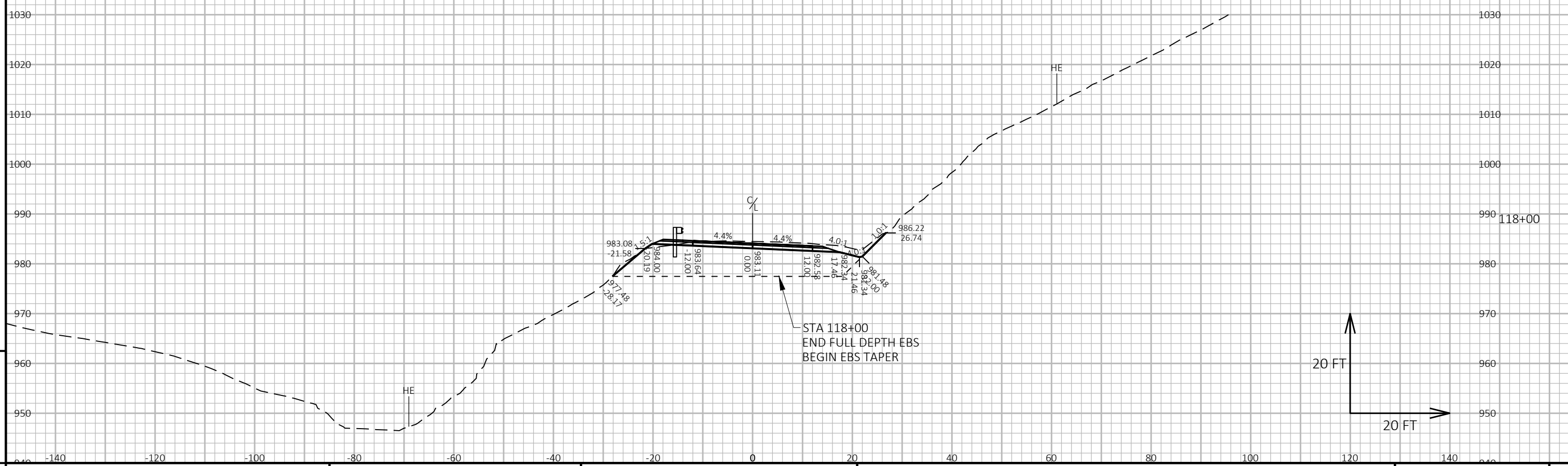
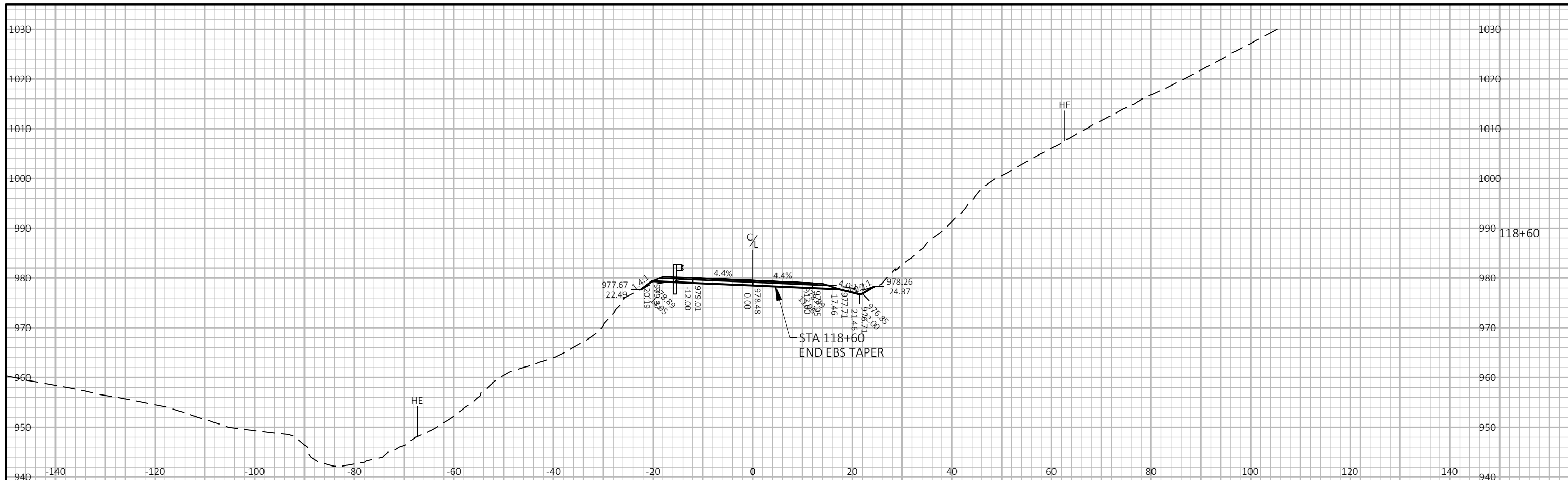

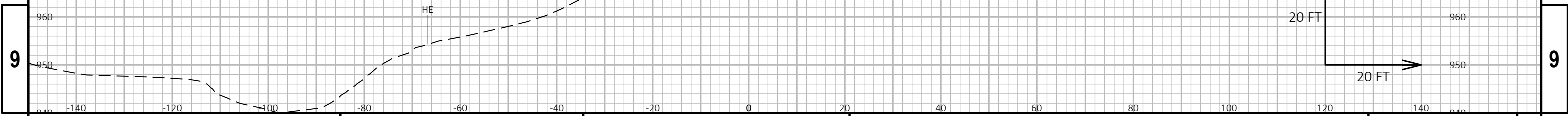
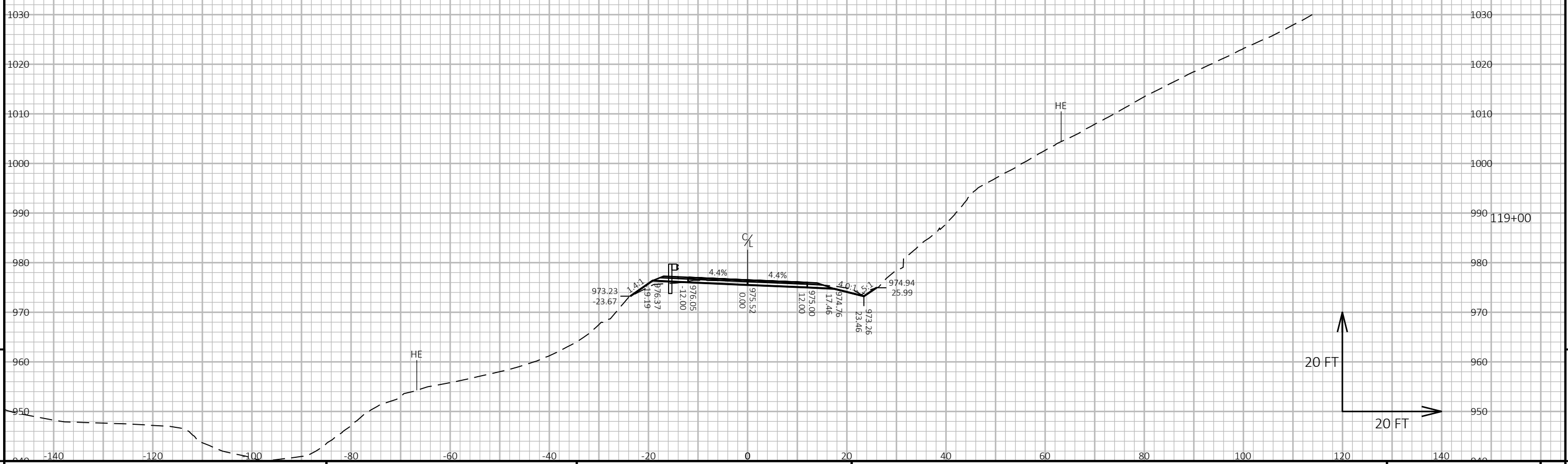
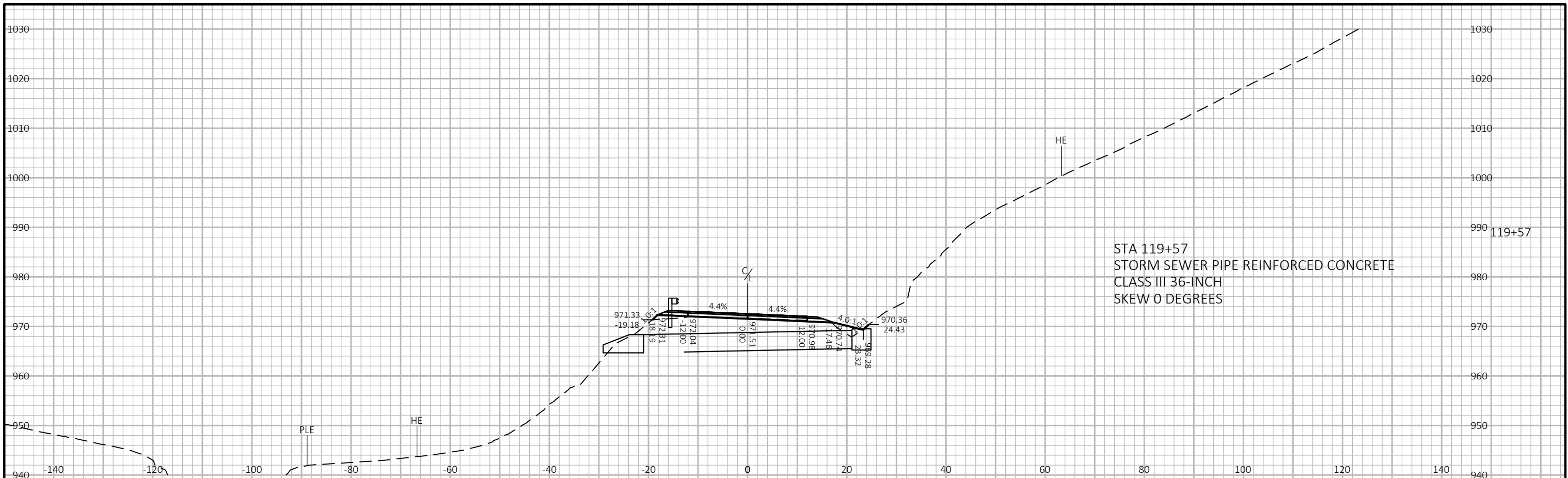

PROJECT NO: 5305-00-71 HWY: CTH SS COUNTY: VERNON CROSS SECTIONS: CTH SS SHEET: 9

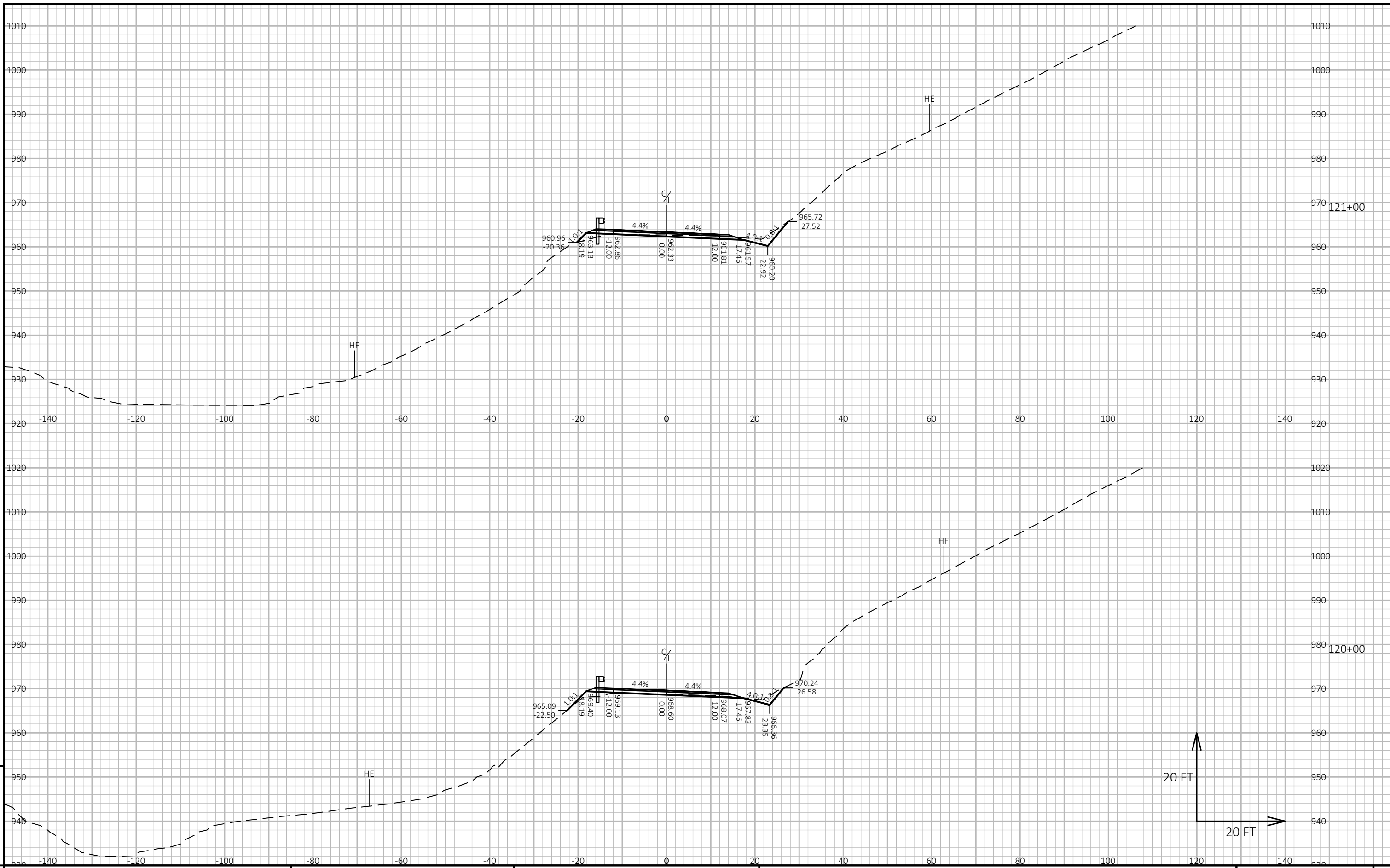

9

9

PROJECT NO: 5305-00-71 HWY: CTH SS COUNTY: VERNON CROSS SECTIONS: CTH SS SHEET E

FILE NAME : X:\UZ\VERHD\164916\5-FINAL-DSGN\51-DRAWINGS\40-TRANSHWY\C3D\164916\SHEETSPLAN\SEC 09 B CROSS SECTIONS\090201-XS (CROSS-SECTIONS).DWG PLOT DATE : 9/28/2023 12:25 PM PLOT BY : SAVANNAH STEHN PLOT NAME : PLOT SCALE : 1 IN:20 FT HORZ. / 1 IN:20 FT VERT. WISDOT/CADD SHEET 49

LAYOUT NAME - 76

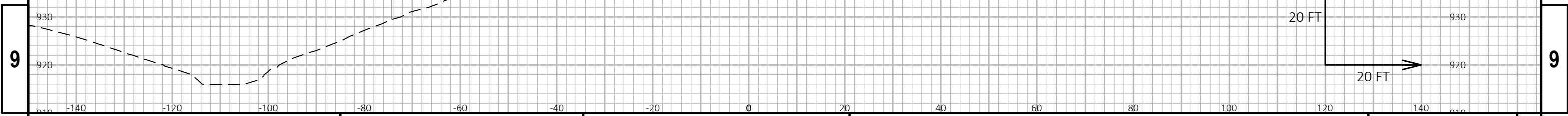
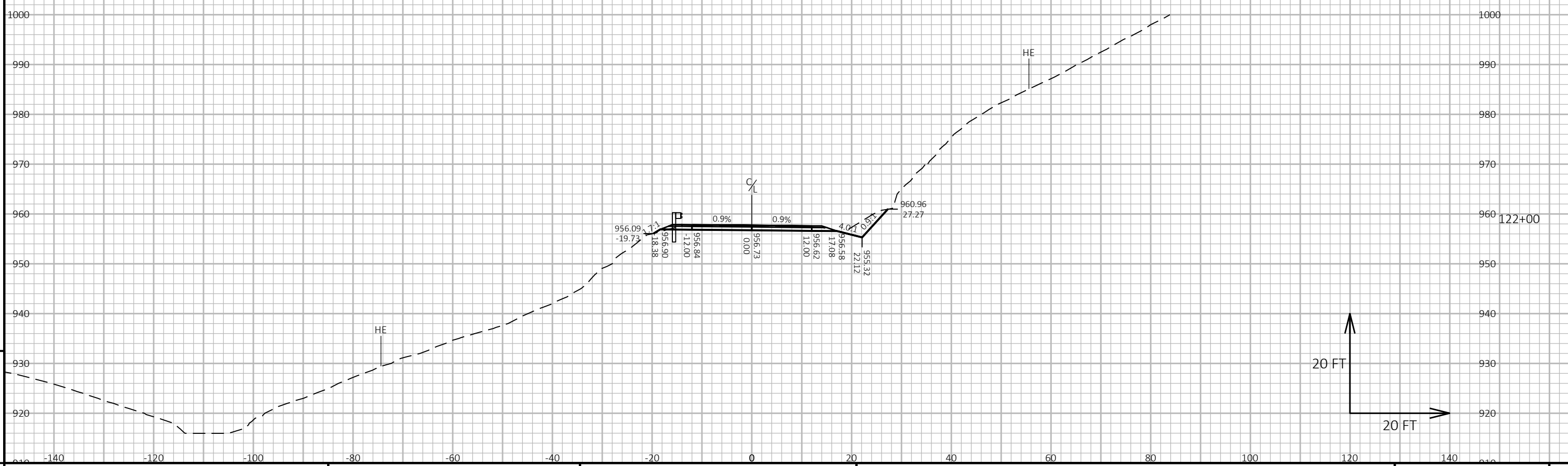
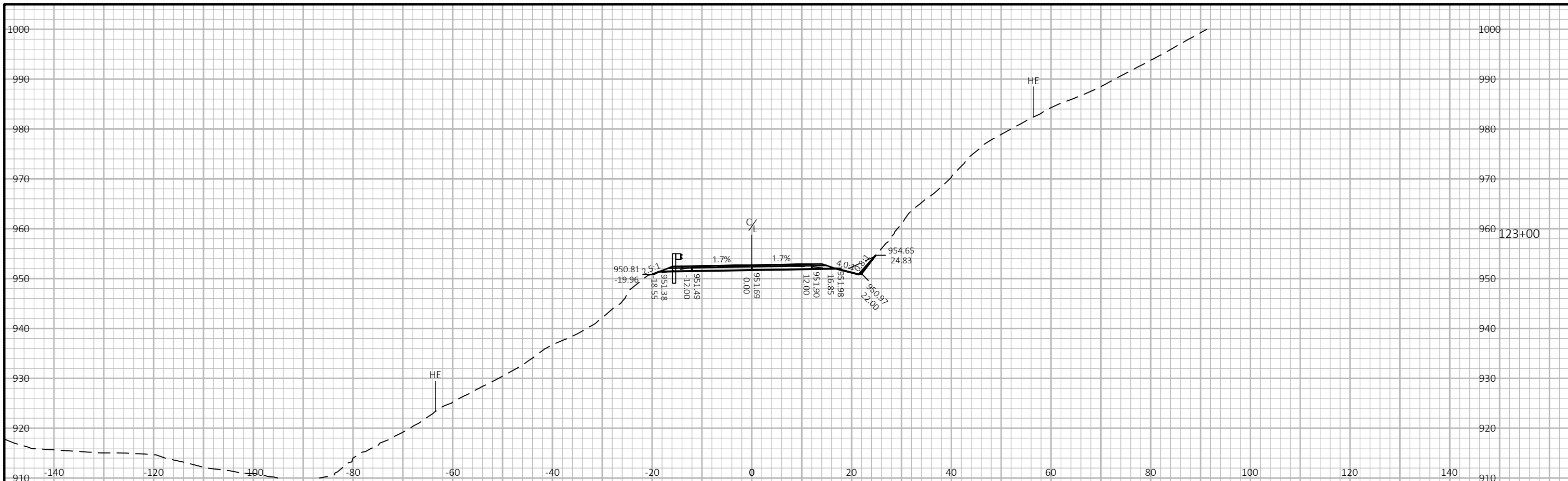

PROJECT NO: 5305-00-71 HWY: CTH SS COUNTY: VERNON CROSS SECTIONS: CTH SS SHEET: 9

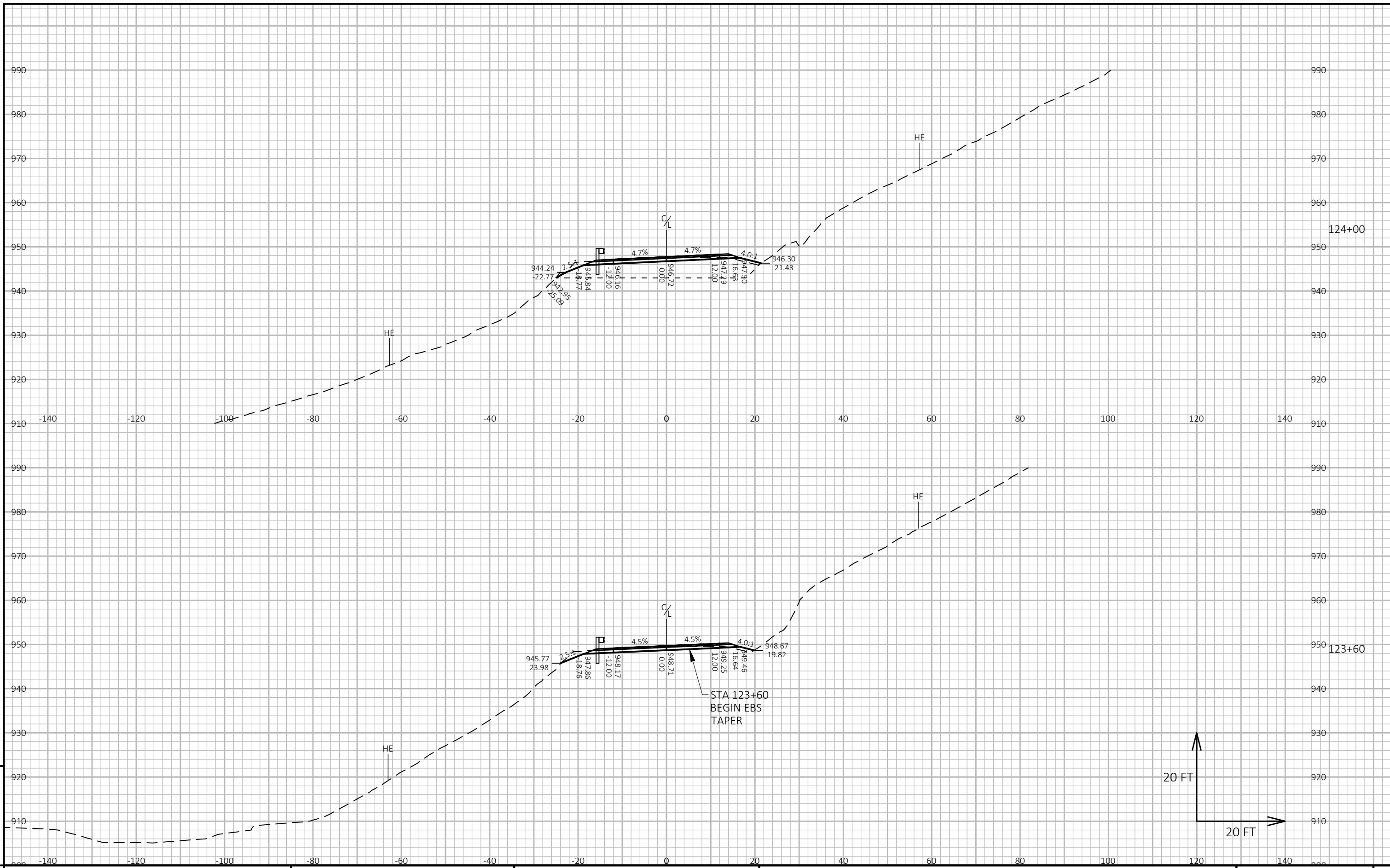

9

9

20 FT

20 FT

PROJECT NO: 5305-00-71 HWY: CTH SS COUNTY: VERNON CROSS SECTIONS: CTH SS SHEET E

FILE NAME : X:\UZ\VERHD\164916\5-FINAL-DSGN\51-DRAWINGS\40-TRANSHWY\C3D\164916\SHEETSPLAN\SEC 09 B CROSS SECTIONS\090201-XS (CROSS-SECTIONS).DWG PLOT DATE : 9/29/2023 12:06 PM PLOT BY : SAVANNAH STEHN PLOT NAME : PLOT SCALE : 1 IN:20 FT HORZ. / 1 IN:20 FT VERT. WISDOT/CADD SHEET 49

LAYOUT NAME - 78

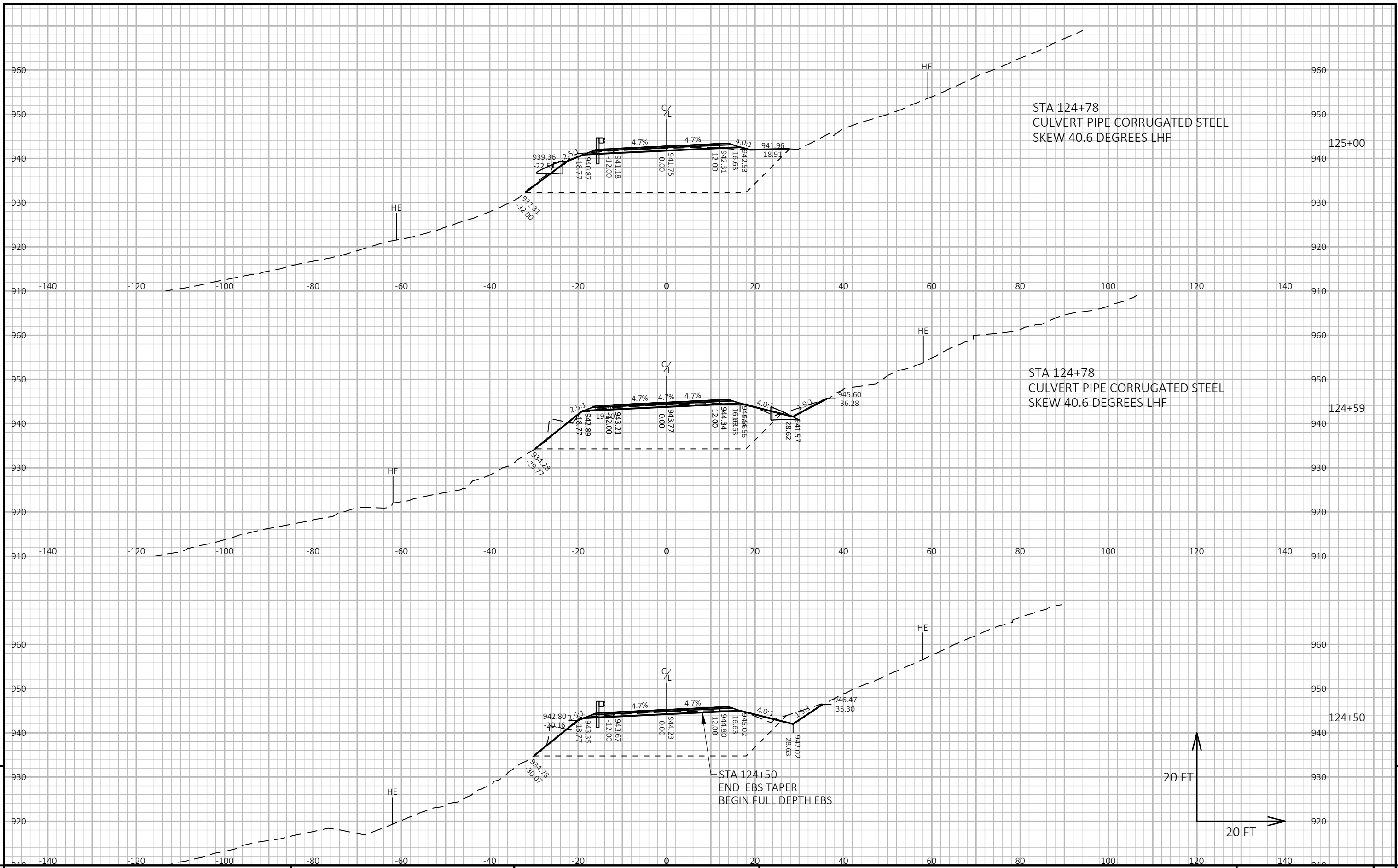

9

9

PROJECT NO: 5305-00-71 HWY: CTH SS COUNTY: VERNON CROSS SECTIONS: CTH SS SHEET E

FILE NAME : X:\UZ\VERHD\164916\5-FINAL-DSGN\51-DRAWINGS\40-TRANSHWY\C3D\164916\SHEETSPLAN\SEC 09 B CROSS SECTIONS\090201-XS (CROSS-SECTIONS).DWG PLOT DATE : 9/29/2023 12:08 PM PLOT BY : SAVANNAH STEHN PLOT NAME : PLOT SCALE : 1 IN:20 FT HORZ. / 1 IN:20 FT VERT. WISDOT/CADD SHEET 49

LAYOUT NAME - 79

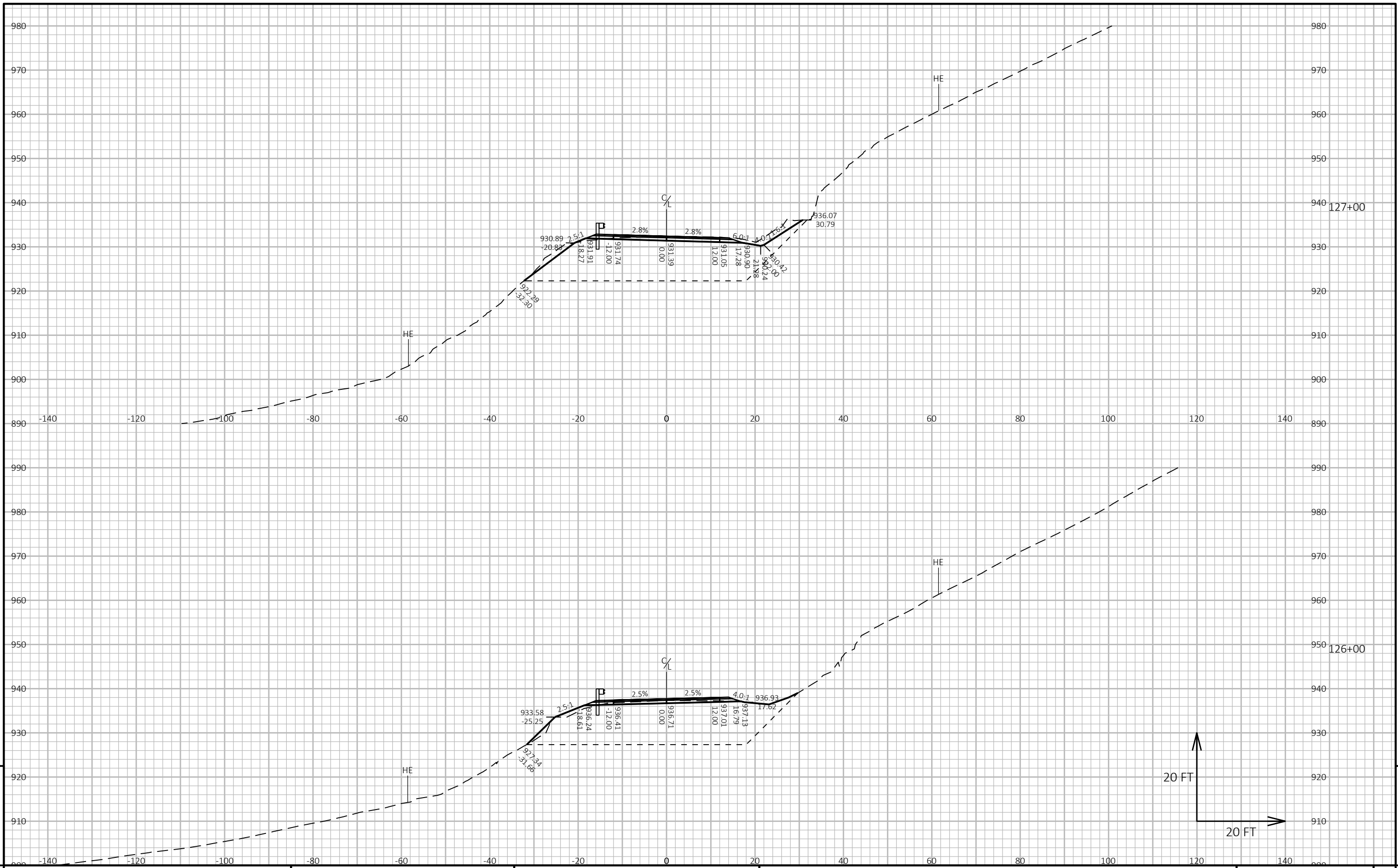

9

9

PROJECT NO: 5305-00-71 HWY: CTH SS COUNTY: VERNON CROSS SECTIONS: CTH SS SHEET E

FILE NAME : X:\UZ\VERHD\164916\5-FINAL-DSGN\51-DRAWINGS\40-TRANSHWY\C3D\164916\SHEETSPLAN\SEC 09 B CROSS SECTIONS\090201-XS (CROSS-SECTIONS).DWG PLOT DATE : 9/29/2023 12:09 PM PLOT BY : SAVANNAH STEHN PLOT NAME : PLOT SCALE : 1 IN:20 FT HORZ. / 1 IN:20 FT VERT. WISDOT/CADD SHEET 49

LAYOUT NAME - 80

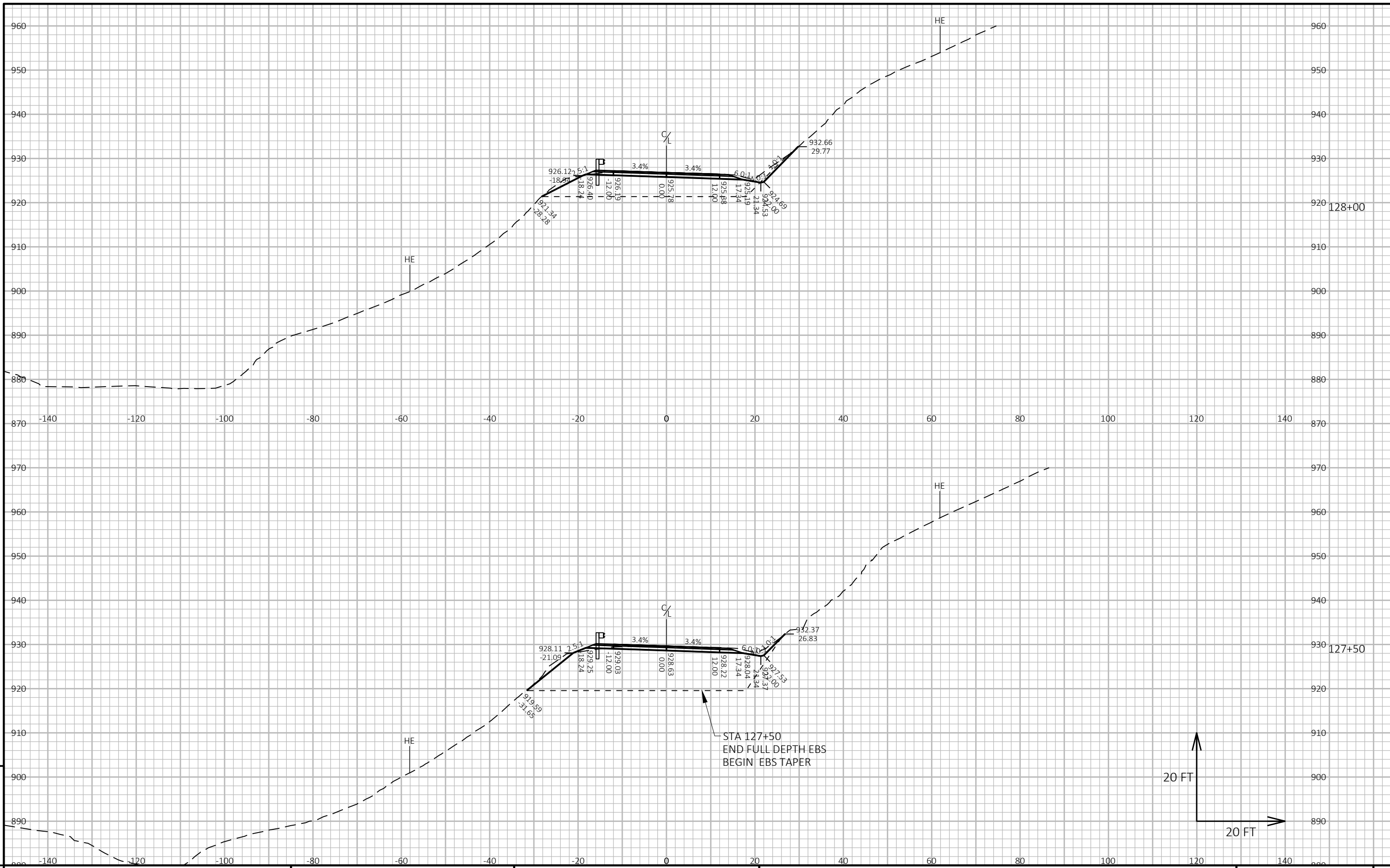

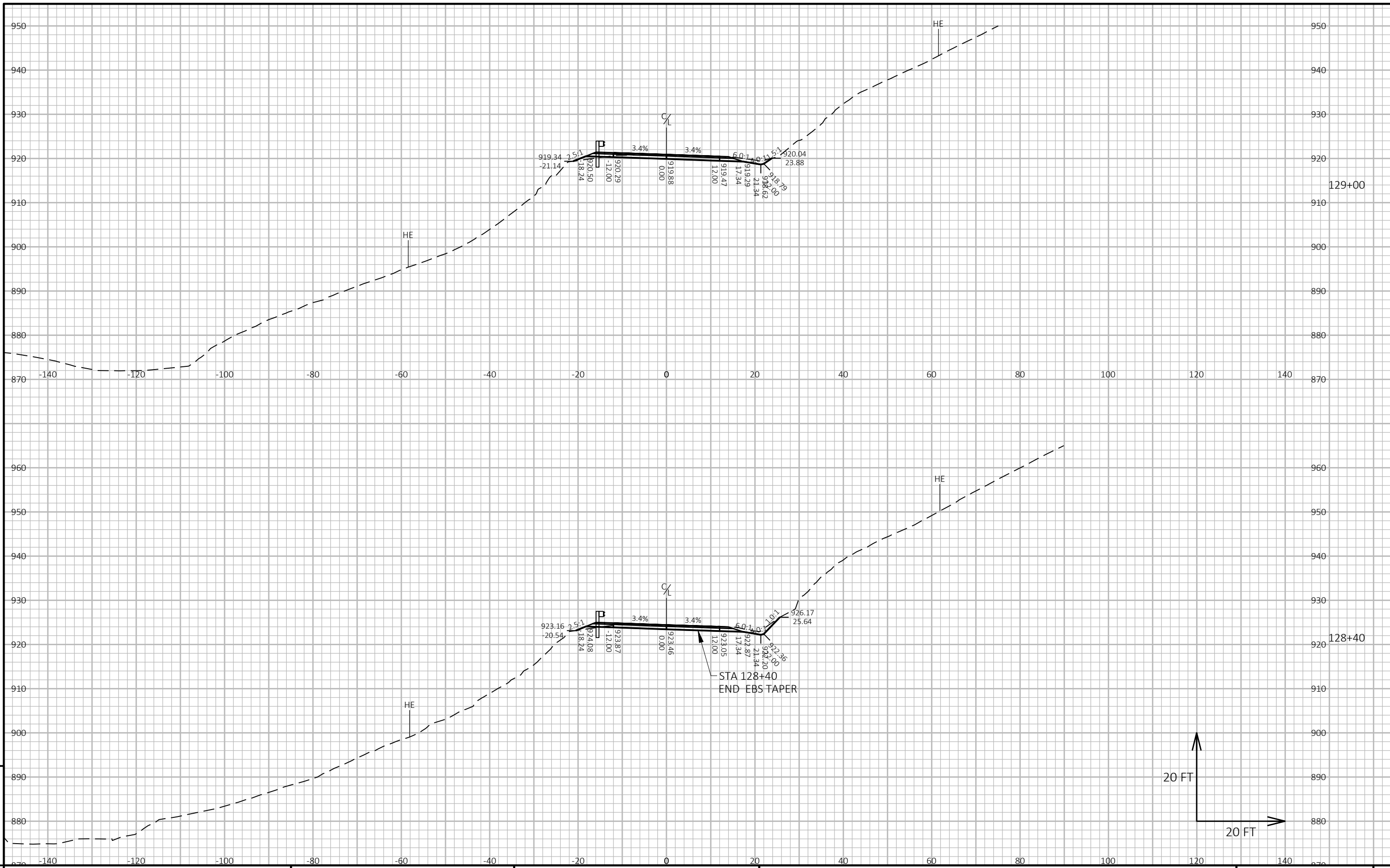

9

9

PROJECT NO: 5305-00-71 HWY: CTH SS COUNTY: VERNON CROSS SECTIONS: CTH SS SHEET E

FILE NAME : X:\UZ\VERHD\164916\5-FINAL-DSGN\51-DRAWINGS\40-TRANSHWY\C3D\164916\SHEETSPLAN\SEC 09 B CROSS SECTIONS\090201-XS (CROSS-SECTIONS).DWG PLOT DATE : 9/28/2023 12:47 PM PLOT BY : SAVANNAH STEHN PLOT NAME : PLOT SCALE : 1 IN:20 FT HORZ. / 1 IN:20 FT VERT. WISDOT/CADD SHEET 49

LAYOUT NAME - 82

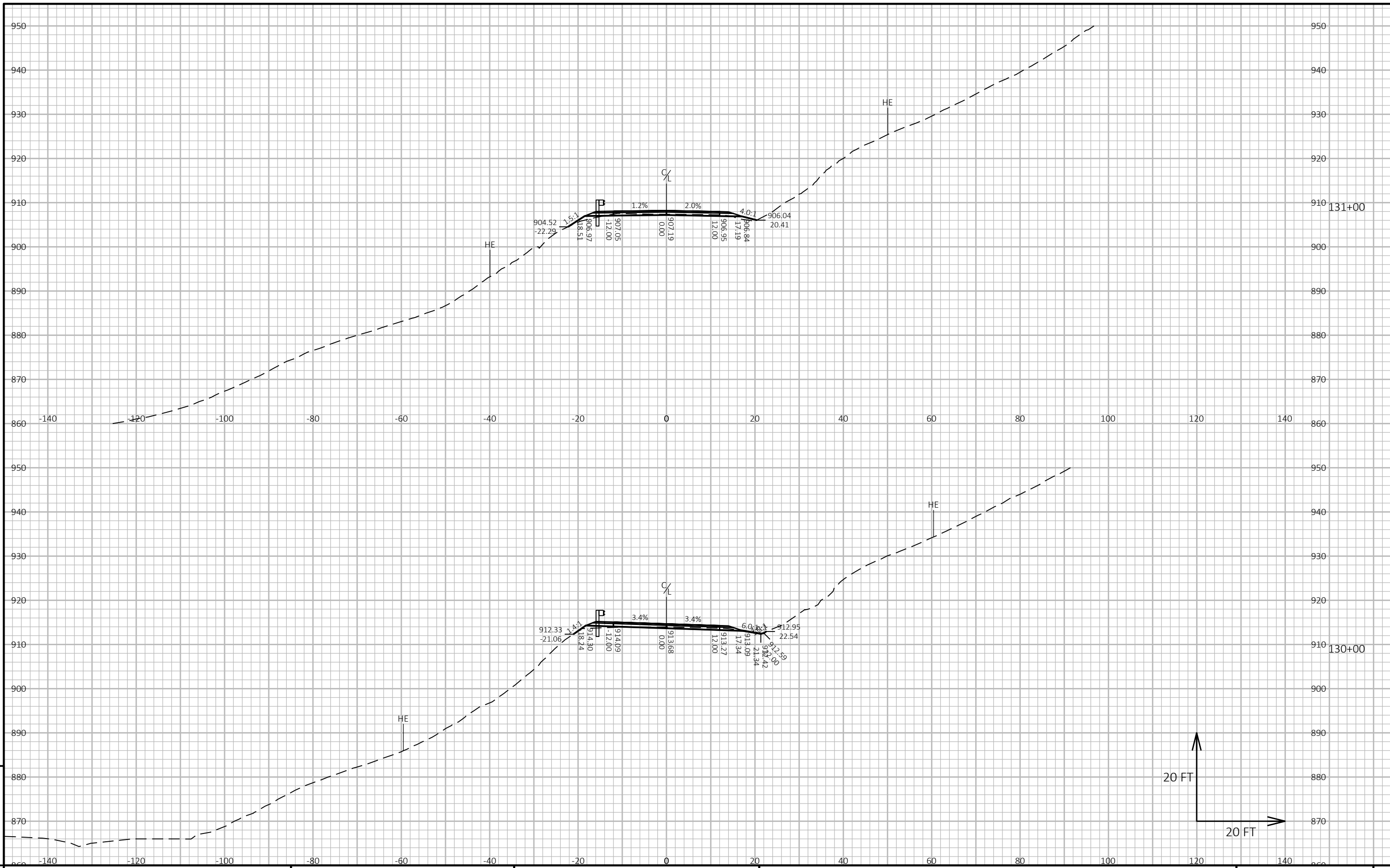

9

9

PROJECT NO: 5305-00-71 HWY: CTH SS COUNTY: VERNON CROSS SECTIONS: CTH SS SHEET E

FILE NAME : X:\UZ\VERHD\164916\5-FINAL-DSGN\51-DRAWINGS\40-TRANSHWY\C3D\164916\SHEETSPLAN\SEC 09 B CROSS SECTIONS\090201-XS (CROSS-SECTIONS).DWG PLOT DATE : 9/28/2023 12:48 PM PLOT BY : SAVANNAH STEHN PLOT NAME : PLOT SCALE : 1 IN:20 FT HORZ. / 1 IN:20 FT VERT. WISDOT/CADD SHEET 49

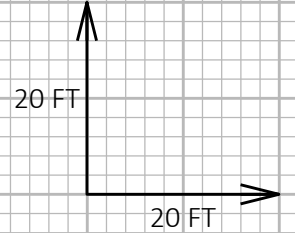

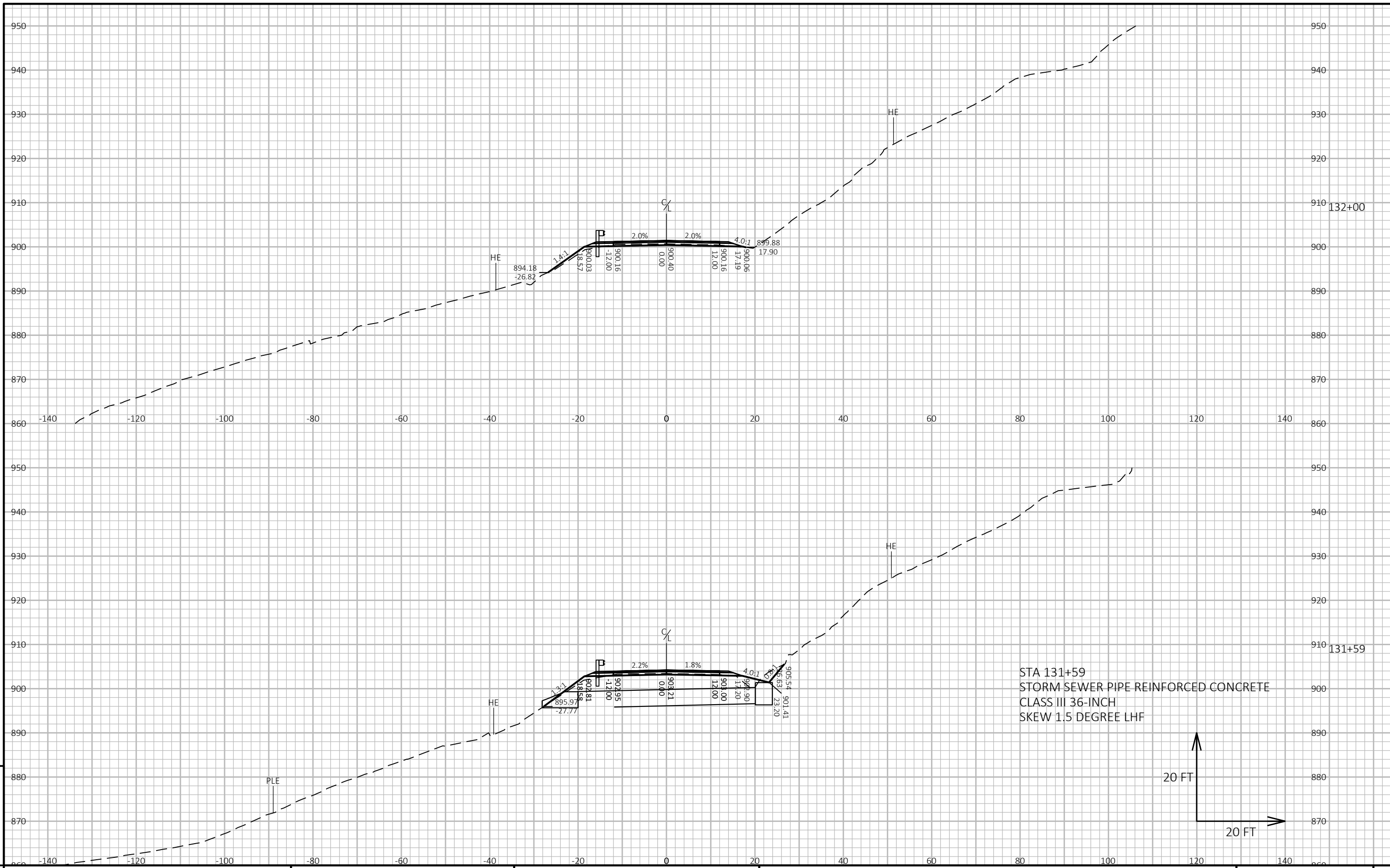

PROJECT NO: 5305-00-71

HWY: CTH SS

COUNTY: VERNON

CROSS SECTIONS: CTH SS

SHEET

E

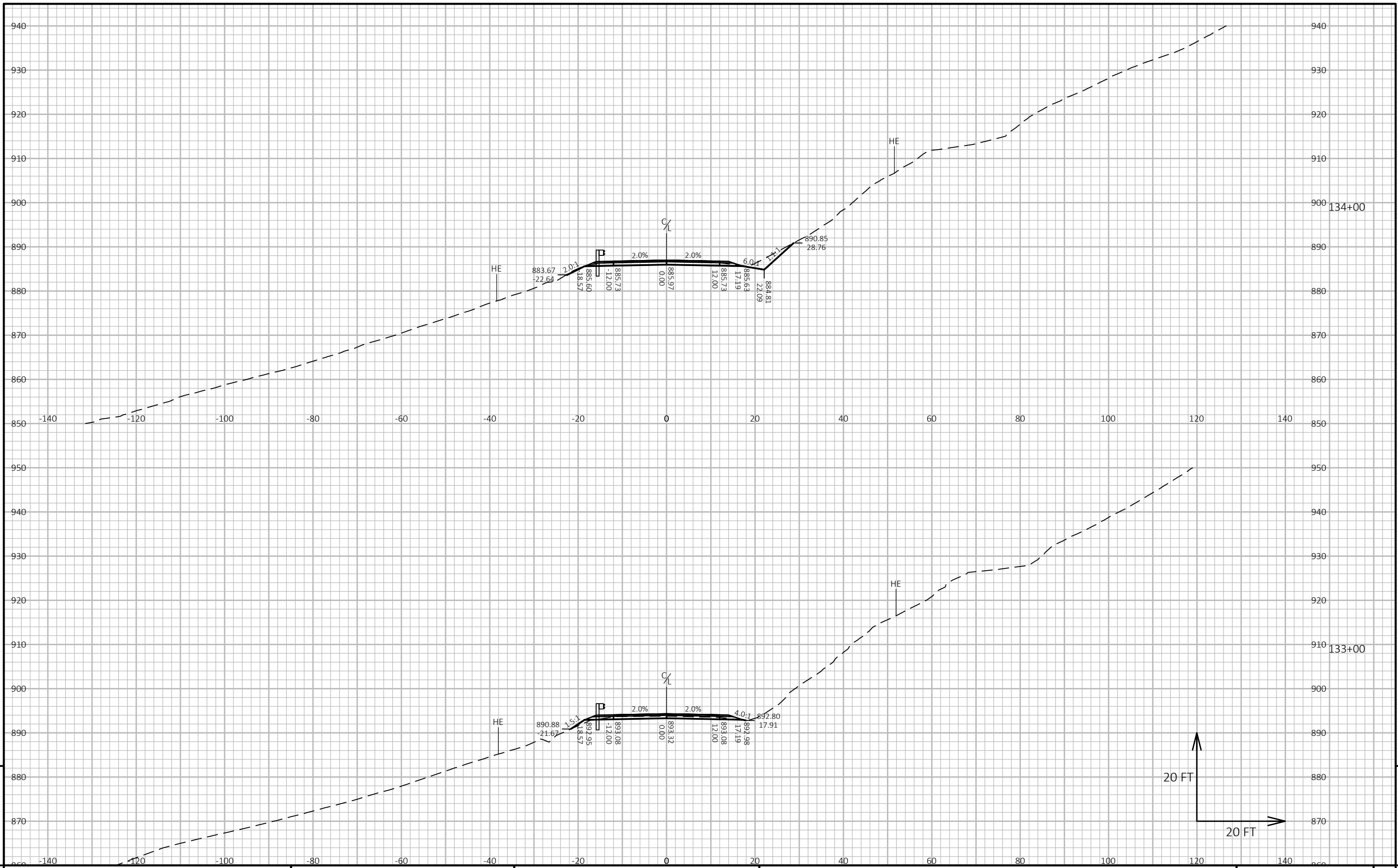

9

9

PROJECT NO: 5305-00-71 HWY: CTH SS COUNTY: VERNON CROSS SECTIONS: CTH SS SHEET E

FILE NAME : X:\UZ\VERHD\164916\5-FINAL-DSGN\51-DRAWINGS\40-TRANSHWY\C3D\164916\SHEETSPLAN\SEC 09 B CROSS SECTIONS\090201-XS (CROSS-SECTIONS).DWG PLOT DATE : 9/28/2023 1:07 PM PLOT BY : SAVANNAH STEHN PLOT NAME : PLOT SCALE : 1 IN:20 FT HORZ. / 1 IN:20 FT VERT. WISDOT/CADD SHEET 49

LAYOUT NAME - 85

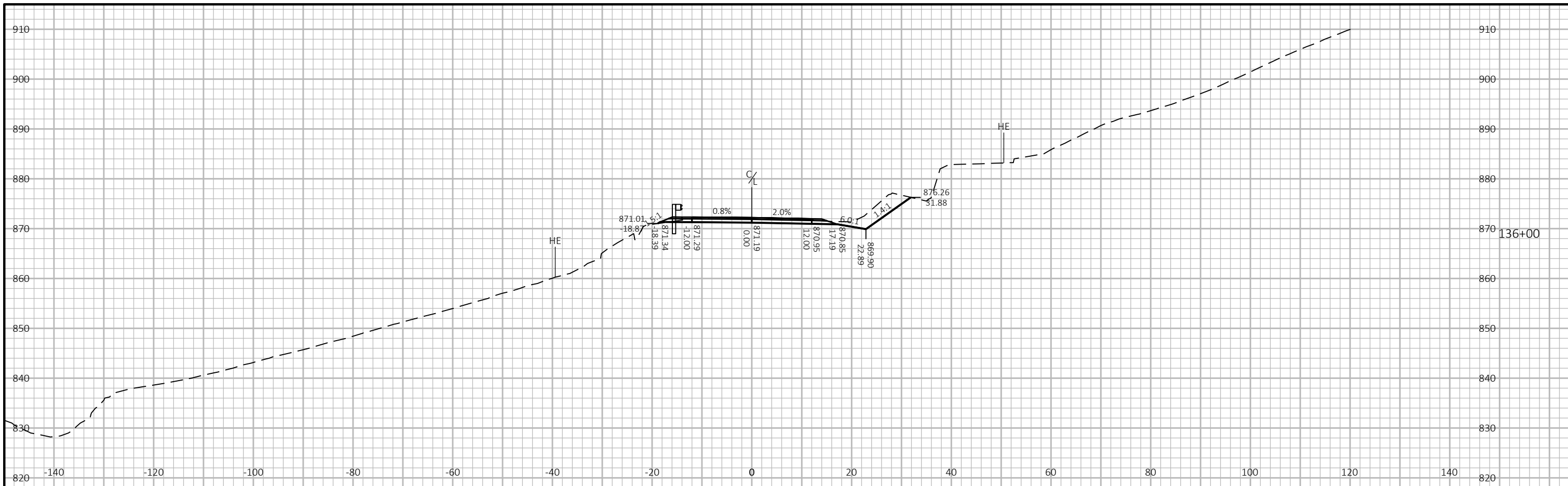

136+00

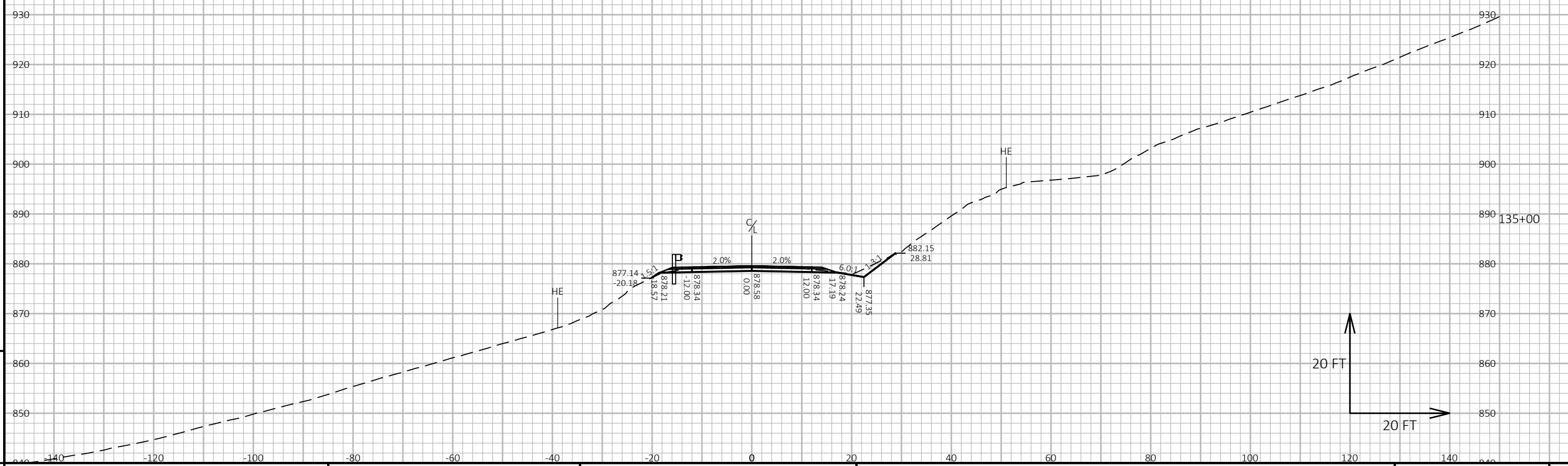

135+00

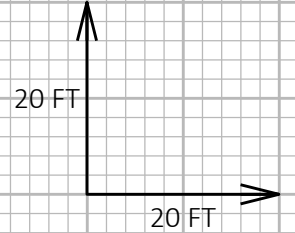

9	PROJECT NO: 5305-00-71	HWY: CTH SS	COUNTY: VERNON	CROSS SECTIONS: CTH SS	SHEET	9
---	------------------------	-------------	----------------	------------------------	-------	---

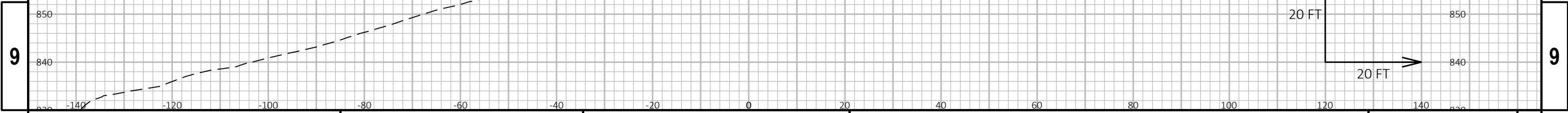
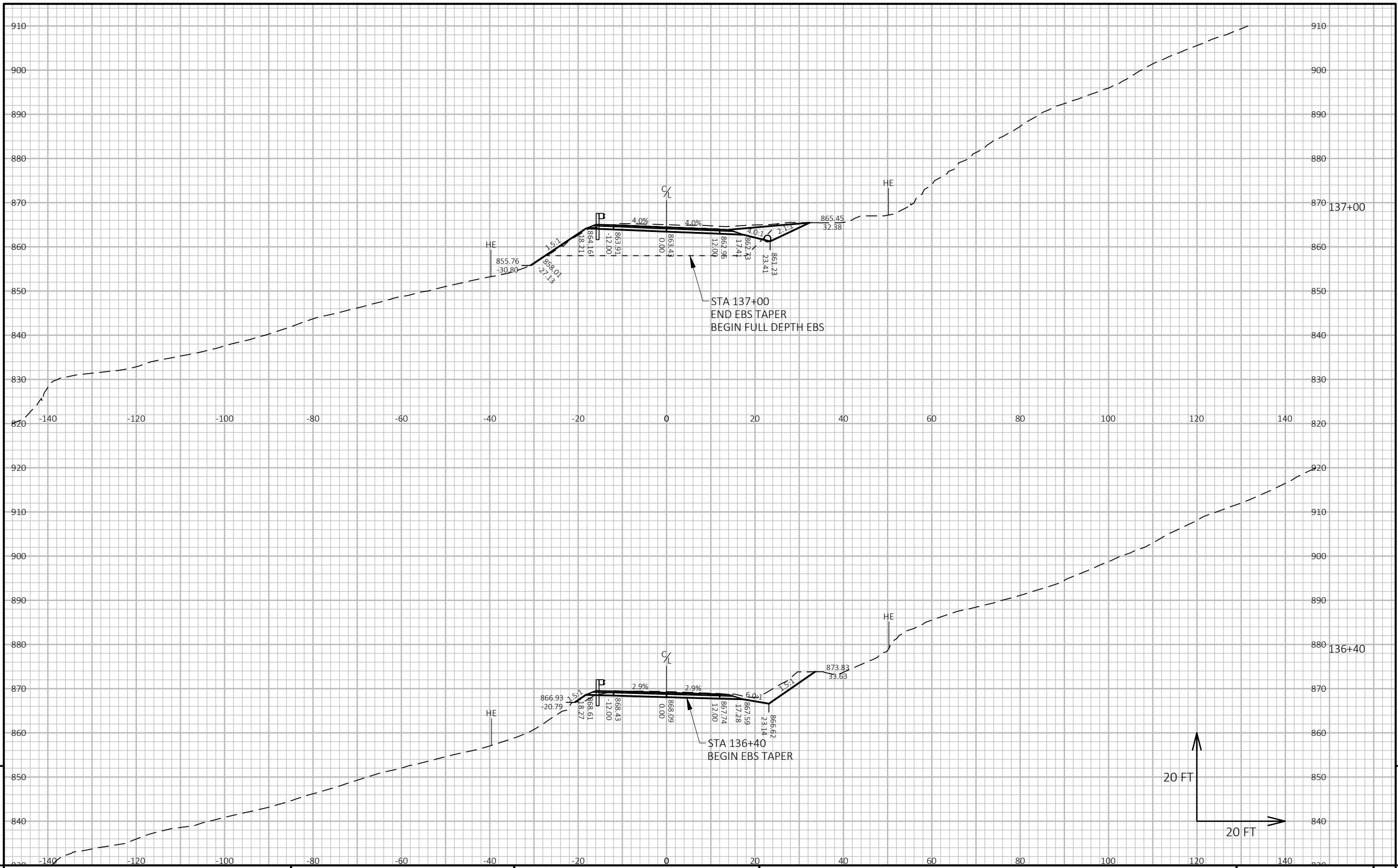

PROJECT NO: 5305-00-71 HWY: CTH SS COUNTY: VERNON CROSS SECTIONS: CTH SS SHEET: 9

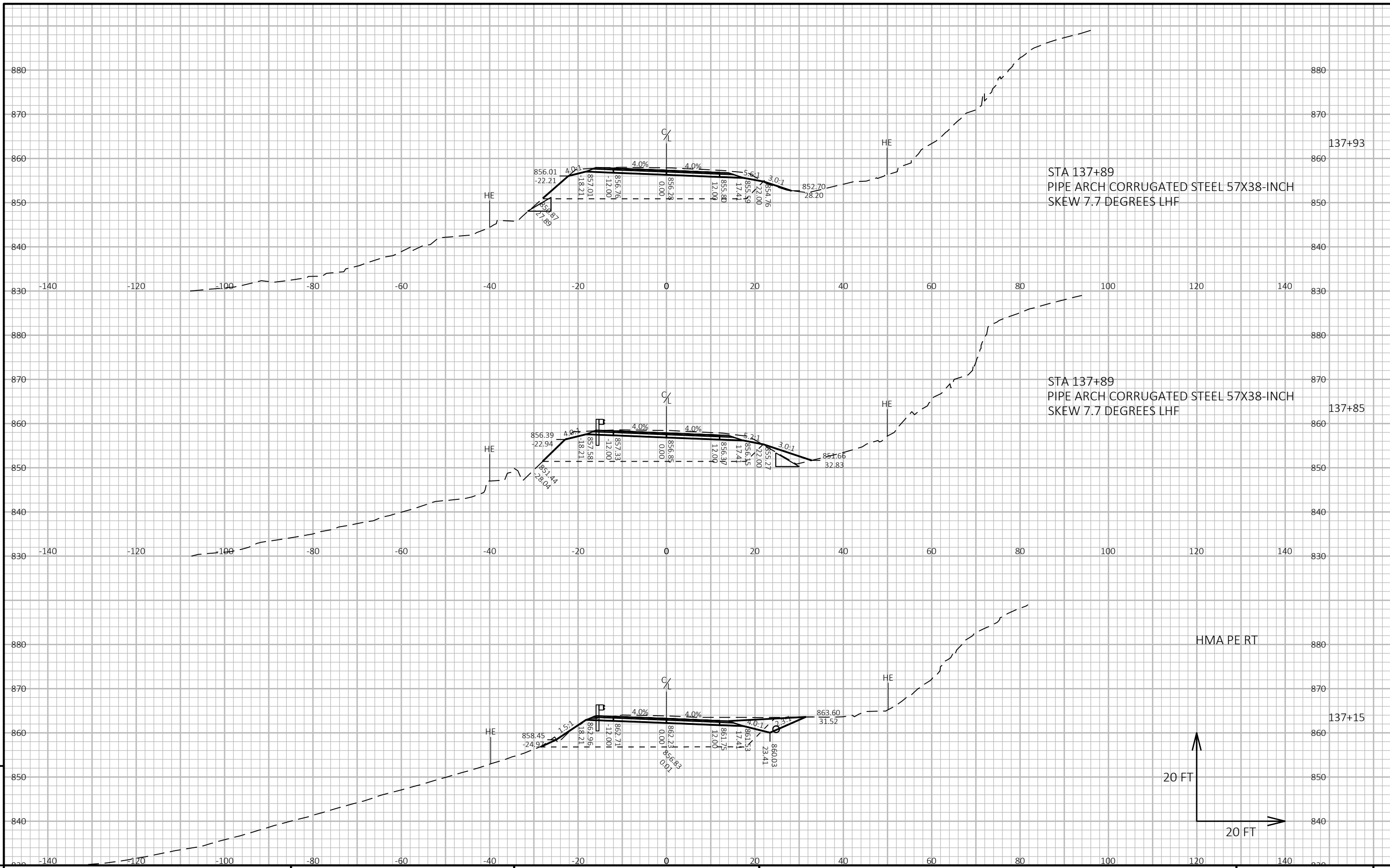

STA 137+93
 PIPE ARCH CORRUGATED STEEL 57X38-INCH
 SKEW 7.7 DEGREES LHF

STA 137+85
 PIPE ARCH CORRUGATED STEEL 57X38-INCH
 SKEW 7.7 DEGREES LHF

HMA PE RT

9	PROJECT NO: 5305-00-71	HWY: CTH SS	COUNTY: VERNON	CROSS SECTIONS: CTH SS	SHEET	9
----------	------------------------	-------------	----------------	------------------------	-------	----------

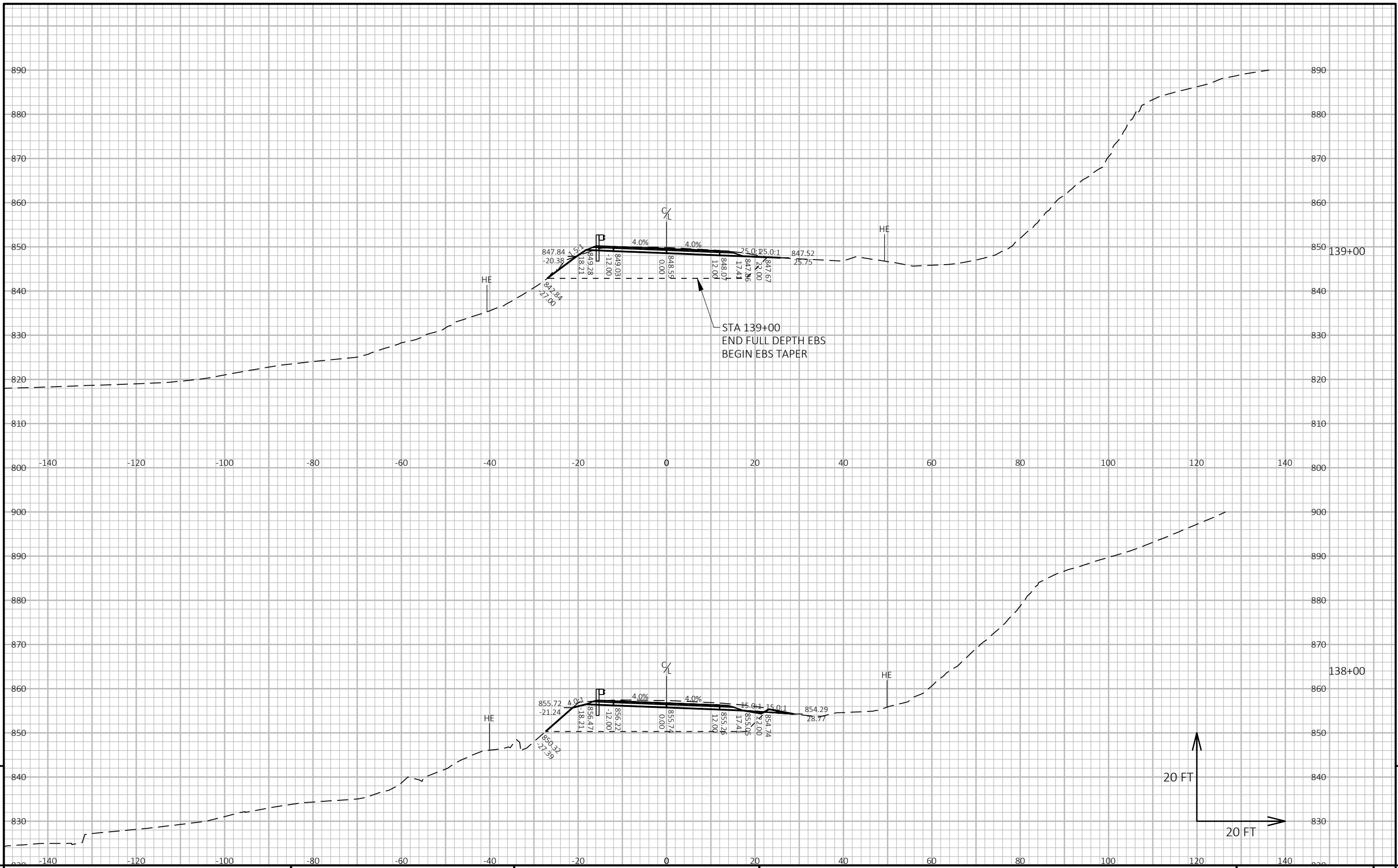

9
PROJECT NO: 5305-00-71
HWY: CTH SS
COUNTY: VERNON
CROSS SECTIONS: CTH SS
SHEET
9

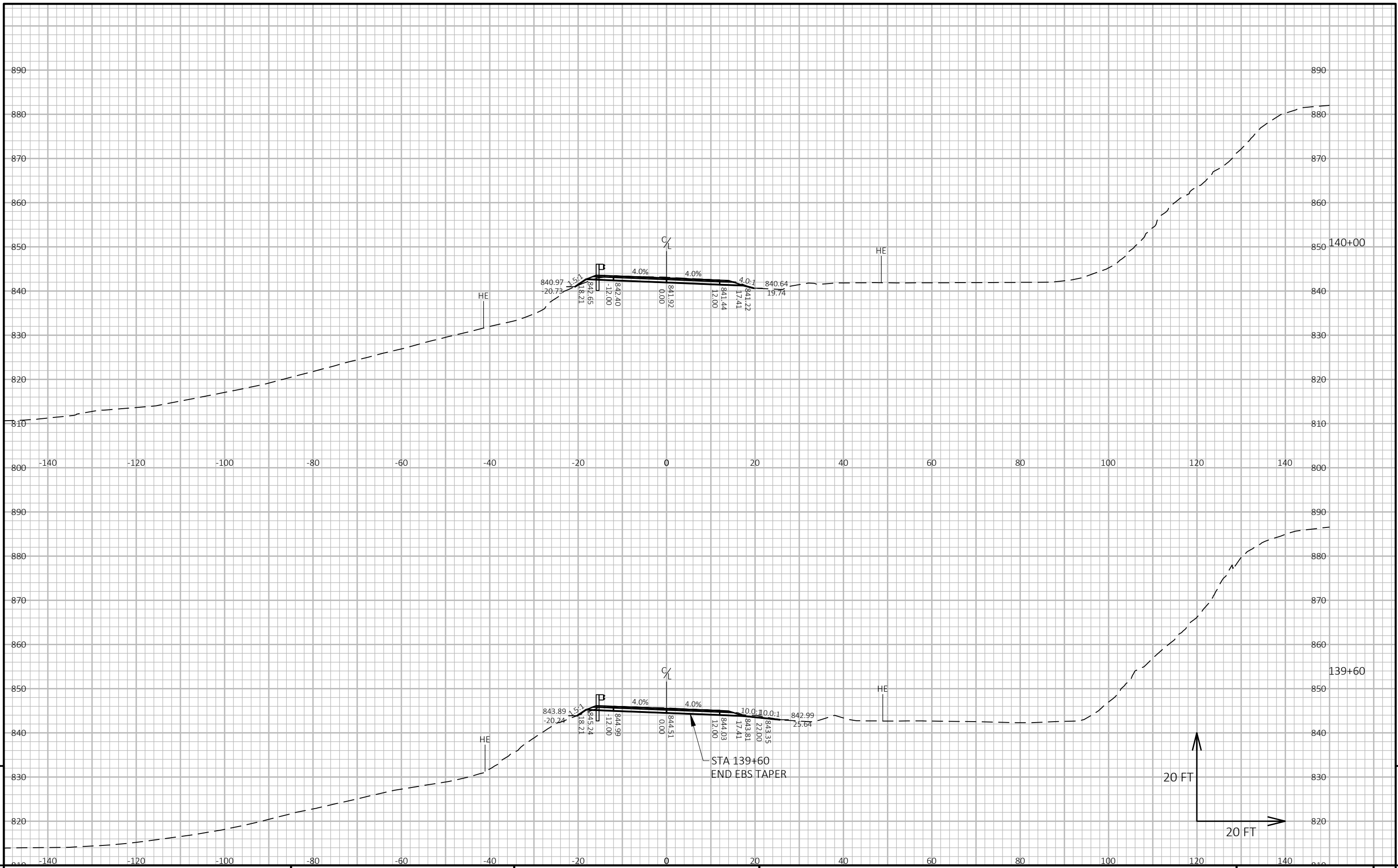

9

9

PROJECT NO: 5305-00-71 HWY: CTH SS COUNTY: VERNON CROSS SECTIONS: CTH SS SHEET E

FILE NAME : X:\UZ\VERHD\164916\5-FINAL-DSGN\51-DRAWINGS\40-TRANSHWY\C3D\164916\SHEETSPLAN\SEC 09 B CROSS SECTIONS\090201-XS (CROSS-SECTIONS).DWG PLOT DATE : 9/29/2023 12:15 PM PLOT BY : SAVANNAH STEHN PLOT NAME : PLOT SCALE : 1 IN:20 FT HORZ. / 1 IN:20 FT VERT. WISDOT/CADD SHEET 49

LAYOUT NAME - 90

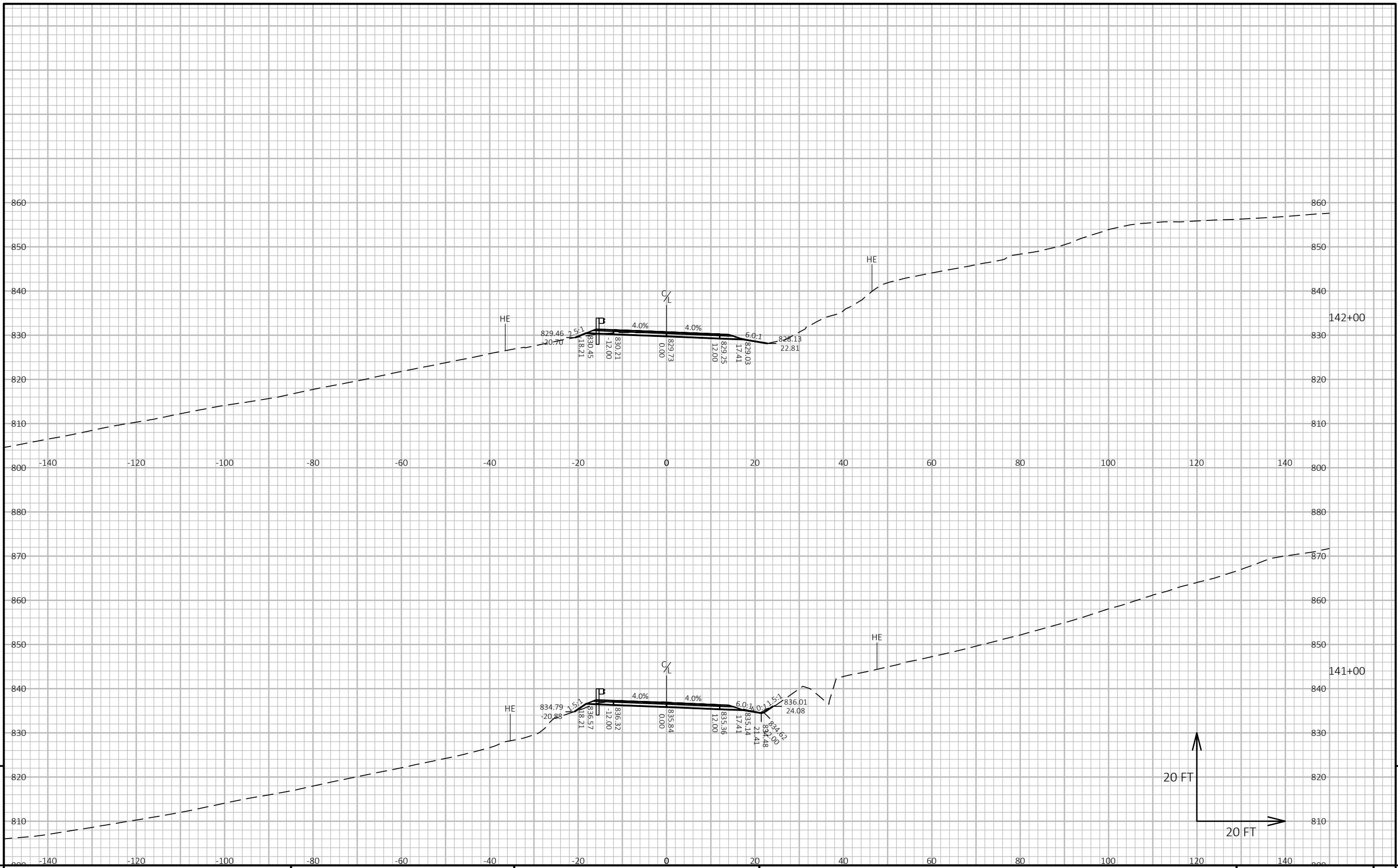

9

9

PROJECT NO: 5305-00-71 HWY: CTH SS COUNTY: VERNON CROSS SECTIONS: CTH SS SHEET E

FILE NAME : X:\UZ\VERHD\164916\5-FINAL-DSGN\51-DRAWINGS\40-TRANSHWY\C3D\164916\SHEETSPLAN\SEC 09 B CROSS SECTIONS\090201-XS (CROSS-SECTIONS).DWG PLOT DATE : 9/29/2023 12:16 PM PLOT BY : SAVANNAH STEHN PLOT NAME : PLOT SCALE : 1 IN:20 FT HORZ. / 1 IN:20 FT VERT. WISDOT/CADD SHEET 49

LAYOUT NAME - 91

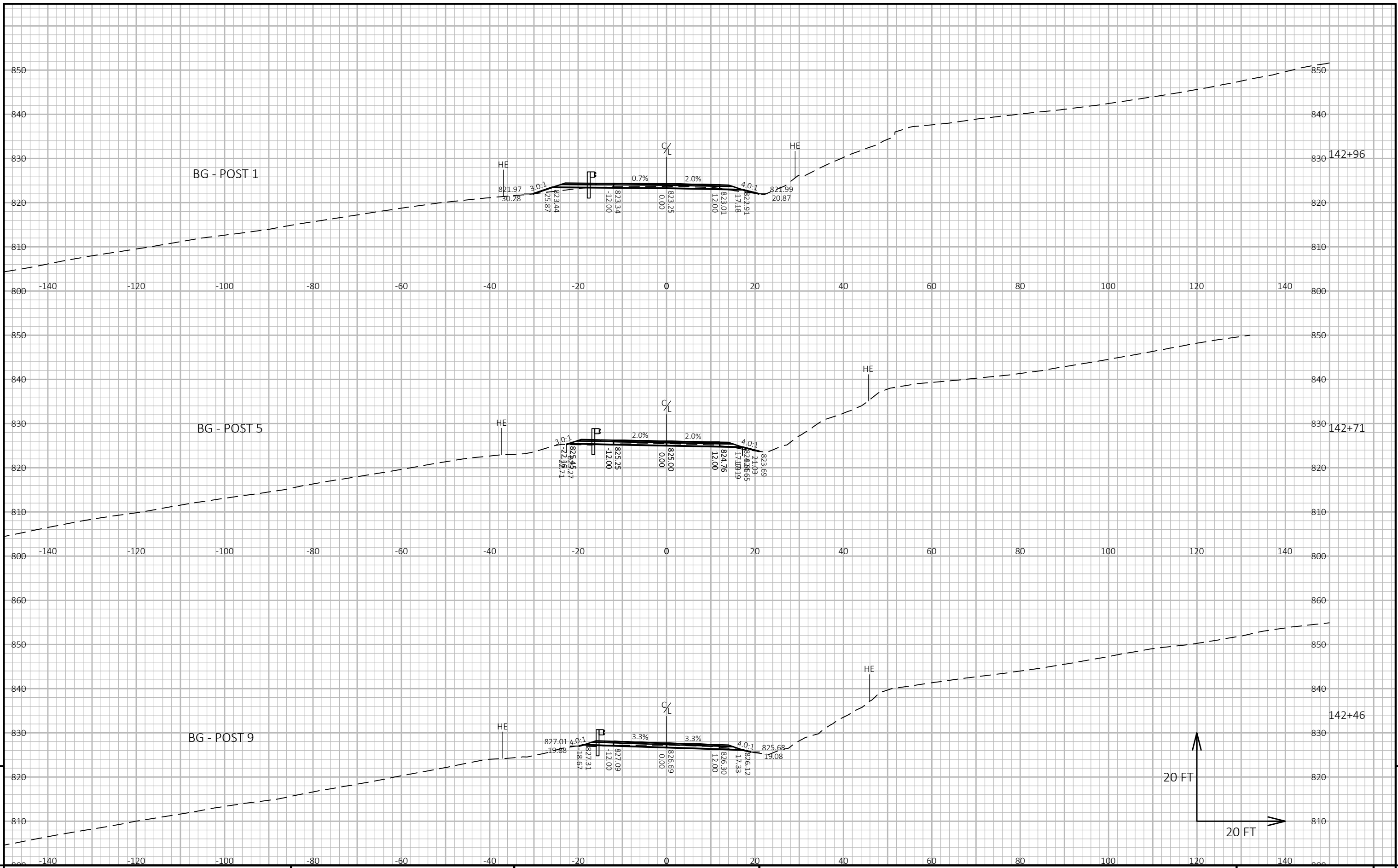

PROJECT NO: 5305-00-71

HWY: CTH SS

COUNTY: VERNON

CROSS SECTIONS: CTH SS

SHEET

E

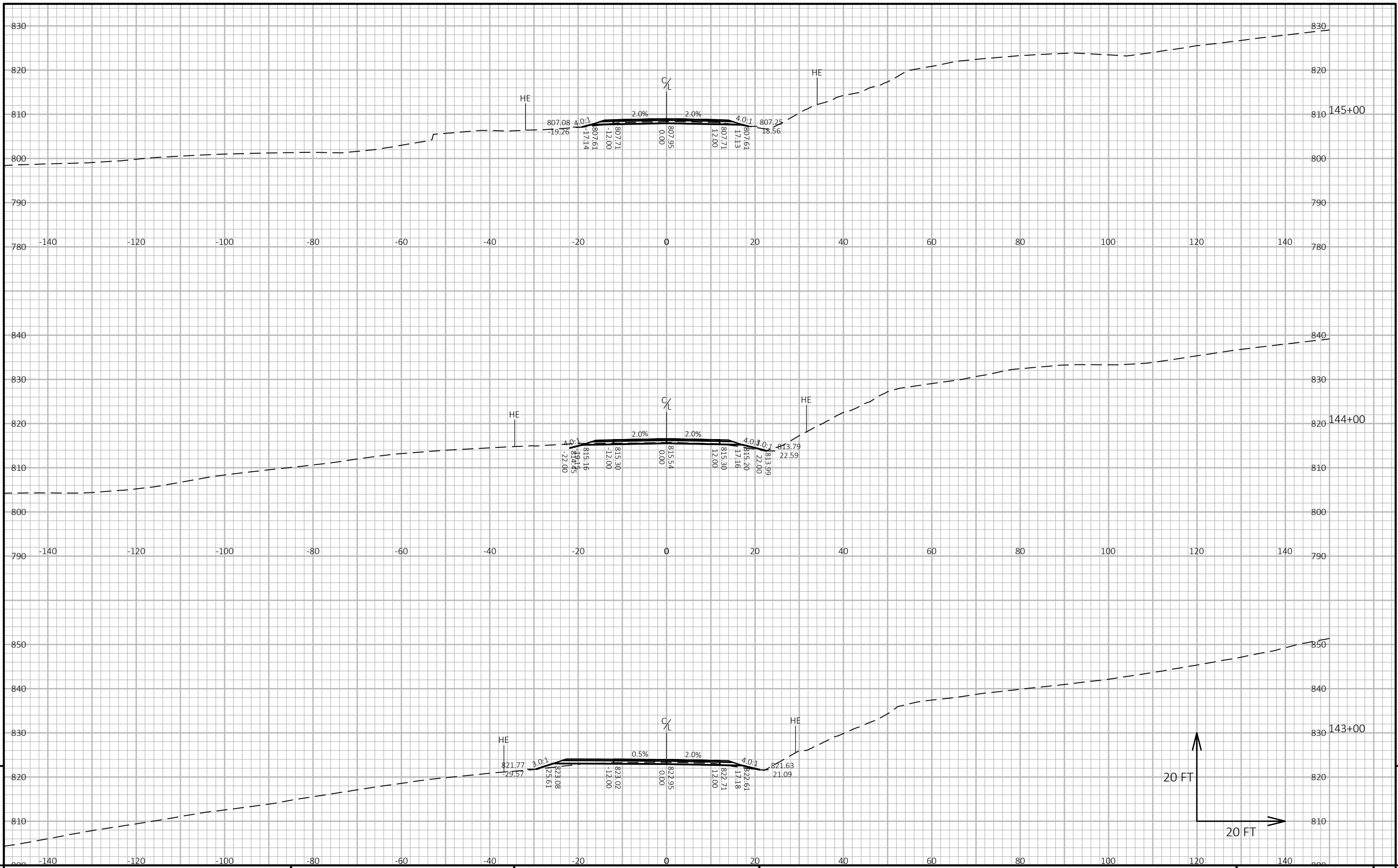

9

9

PROJECT NO: 5305-00-71 HWY: CTH SS COUNTY: VERNON CROSS SECTIONS: CTH SS SHEET E

FILE NAME : X:\UZ\VERHD\164916\5-FINAL-DSGN\51-DRAWINGS\40-TRANSHWY\C3D\164916\SHEETSPLAN\SEC 09 B CROSS SECTIONS\090201-XS (CROSS-SECTIONS).DWG PLOT DATE : 9/29/2023 12:20 PM PLOT BY : SAVANNAH STEHN PLOT NAME : PLOT SCALE : 1 IN:20 FT HORZ. / 1 IN:20 FT VERT. WISDOT/CADD SHEET 49

LAYOUT NAME - 93

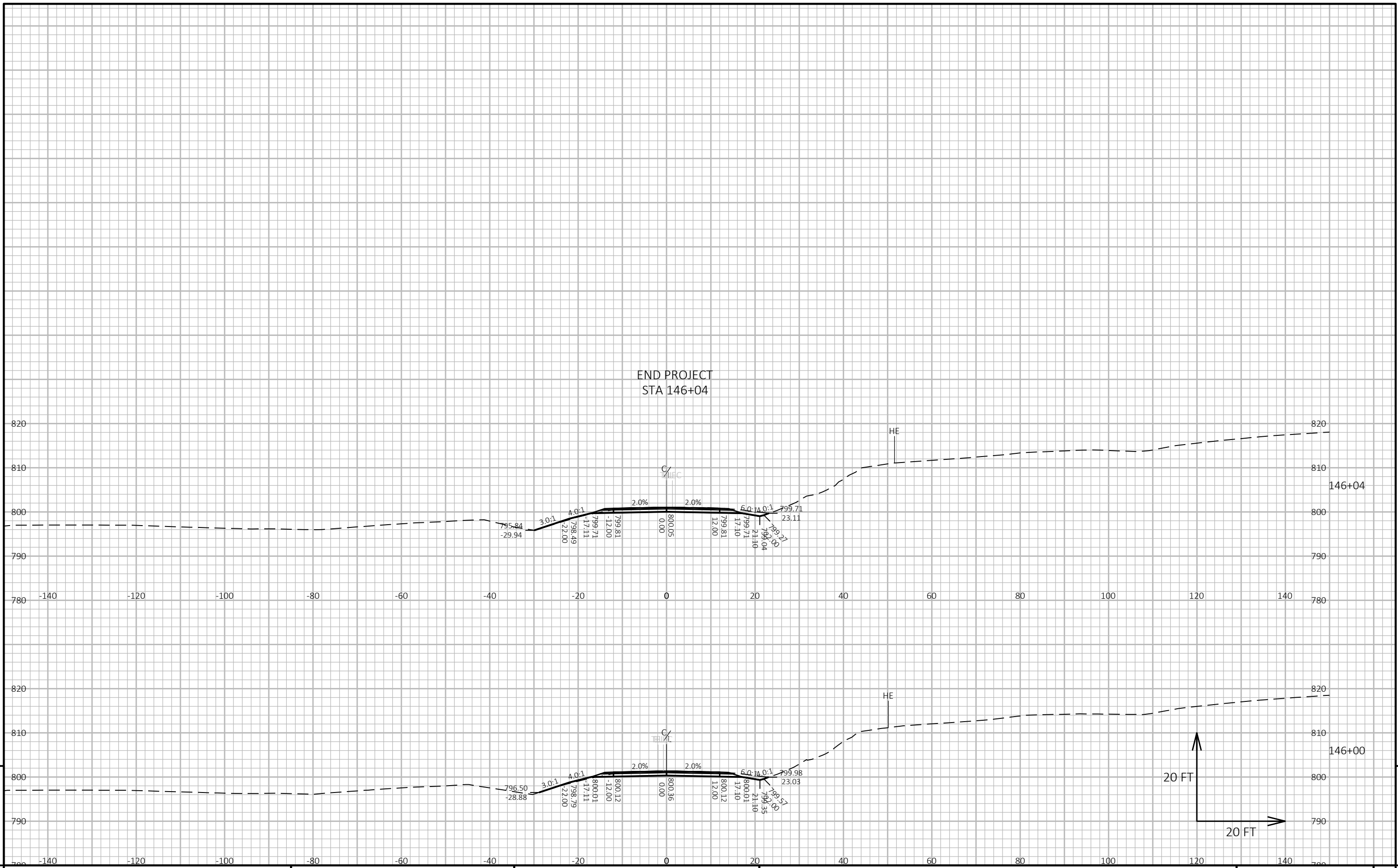

9

9

PROJECT NO: 5305-00-71 HWY: CTH SS COUNTY: VERNON CROSS SECTIONS: CTH SS SHEET E

FILE NAME : X:\UZ\VERHD\164916\5-FINAL-DSGN\51-DRAWINGS\40-TRANSHWY\C3D\164916\SHEETSPLAN\SEC 09 B CROSS SECTIONS\090201-XS (CROSS-SECTIONS).DWG PLOT DATE : 9/29/2023 12:21 PM PLOT BY : SAVANNAH STEHN PLOT NAME : PLOT SCALE : 1 IN:20 FT HORZ. / 1 IN:20 FT VERT. WISDOT/CADD SHEET 49

LAYOUT NAME - 94



Wisconsin Department of Transportation

Dedicated people creating transportation solutions through innovation and exceptional service.

<http://www.dot.wisconsin.gov>